

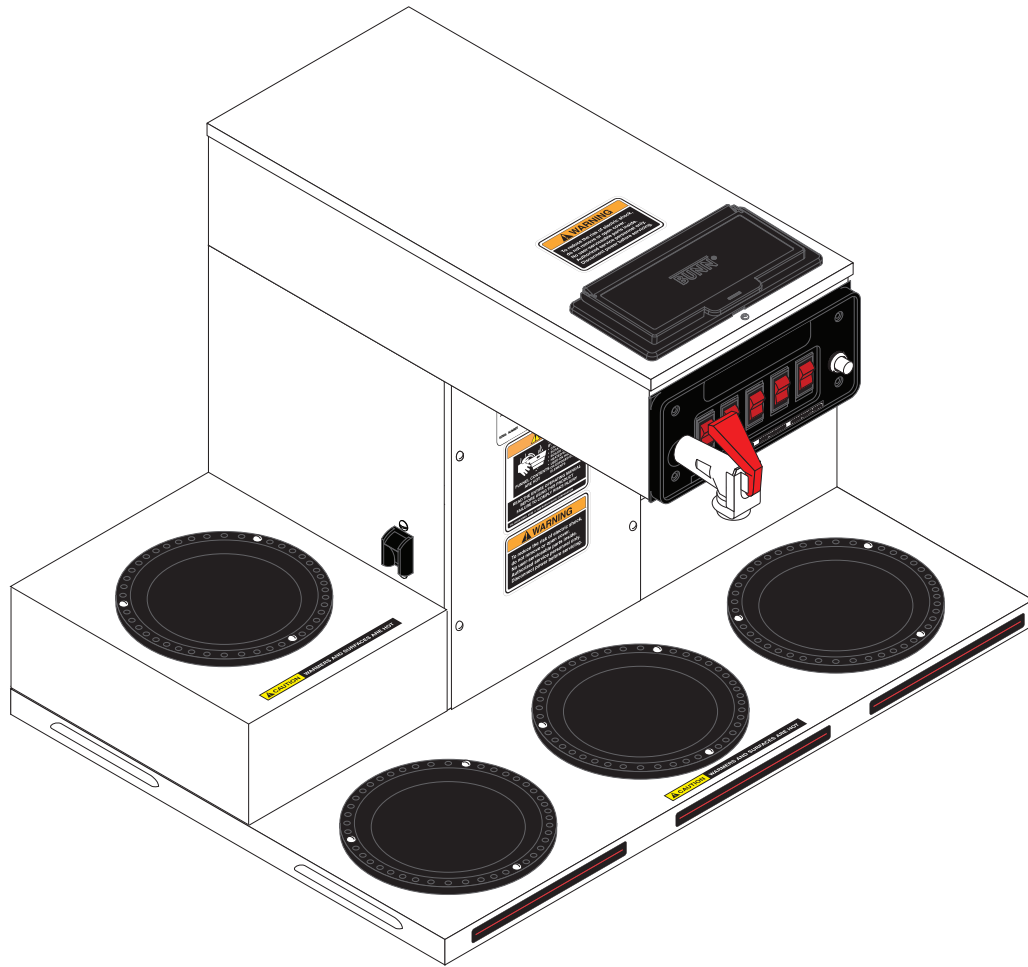

CRT5
CRTF5



INSTALLATION & OPERATING GUIDE

BUNN-O-MATIC CORPORATION

POST OFFICE BOX 3227

SPRINGFIELD, ILLINOIS 62708-3227

PHONE: (217) 529-6601 FAX: (217) 529-6644

To ensure you have the latest revision of the Operating Manual, or to view the Illustrated Parts Catalog, Programming Manual, or Service Manual, please visit the Bunn-O-Matic website, at www.bunn.com. This is absolutely FREE, and the quickest way to obtain the latest catalog and manual updates. For Technical Service, contact Bunn-O-Matic Corporation at 1-800-286-6070.

BUNN-O-MATIC COMMERCIAL PRODUCT WARRANTY

Bunn-O-Matic Corp. ("BUNN") warrants equipment manufactured by it as follows:

- 1) All coffee and tea dispensers/servers, MCR/MCP/MCA single cup brewers, and BUNNlink® electronic circuit and/or control boards – 1 year parts and 1 year labor.
- 2) Product-specific warranties for Crescendo®, Fast Cup®, Sure Immersion®, Sure Tamp®, and others – 1 year parts and 1 year labor. Please visit commercial.bunn.com/support/warranty-lookup for further details.
- 3) All other equipment – 2 years parts and 1 year labor plus added warranties as specified below:
 - a) Electronic circuit and/or control boards – parts and labor for 3 years.
 - b) Compressors on refrigeration equipment – 5 years parts and 1 year labor.
 - c) Grinding burrs on coffee grinding equipment for 4 years or 40,000 pounds of coffee, whichever comes first.

These warranty periods run from the date of installation. BUNN warrants that the equipment manufactured by it will be commercially free of defects in material and workmanship existing at the time of manufacture and appearing within the applicable warranty period. This warranty does not apply to any equipment, component or part that was not manufactured by BUNN or that, in BUNN's judgment, has been affected by misuse, neglect, alteration, improper installation or operation, improper maintenance or repair, non periodic cleaning and descaling, equipment failures related to poor water quality, damage or casualty. In addition, the warranty does not apply to replacement of items subject to normal wear with use including but not limited to user replaceable parts such as seals and gaskets. This warranty is conditioned on the Buyer 1) giving BUNN prompt notice of any claim to be made under this warranty by telephone at (217) 529-6601 or by writing to Post Office Box 3227, Springfield, Illinois 62708-3227; 2) if requested by BUNN, shipping the defective equipment prepaid to an authorized BUNN service location; and 3) receiving prior authorization from BUNN that the defective equipment is under warranty.

THE FOREGOING WARRANTY IS EXCLUSIVE AND IS IN LIEU OF ANY OTHER WARRANTY, WRITTEN OR ORAL, EXPRESS OR IMPLIED, INCLUDING, BUT NOT LIMITED TO, ANY IMPLIED WARRANTY OF EITHER MERCHANTABILITY OR FITNESS FOR A PARTICULAR PURPOSE. The agents, dealers or employees of BUNN are not authorized to make modifications to this warranty or to make additional warranties that are binding on BUNN. Accordingly, statements by such individuals, whether oral or written, do not constitute warranties and should not be relied upon.

If BUNN determines in its sole discretion that the equipment does not conform to the warranty, BUNN, at its exclusive option while the equipment is under warranty, shall either 1) provide at no charge replacement parts and/or labor (during the applicable parts and labor warranty periods specified above) to repair the defective components, provided that this repair is done by a BUNN Authorized Service Representative; or 2) shall replace the equipment or refund the purchase price for the equipment.

THE BUYER'S REMEDY AGAINST BUNN FOR THE BREACH OF ANY OBLIGATION ARISING OUT OF THE SALE OF THIS EQUIPMENT, WHETHER DERIVED FROM WARRANTY OR OTHERWISE, SHALL BE LIMITED, AT BUNN'S SOLE OPTION AS SPECIFIED HEREIN, TO REPAIR, REPLACEMENT OR REFUND.

In no event shall BUNN be liable for any other damage or loss, including, but not limited to, lost profits, lost sales, loss of use of equipment, claims of Buyer's customers, cost of capital, cost of down time, cost of substitute equipment, facilities or services, or any other special, incidental or consequential damages.

USER NOTICES

Carefully read and follow all notices in this manual and on the equipment. All labels on the equipment should be kept in good condition. Replace any unreadable or damaged labels.

⚠ WARNING
<ul style="list-style-type: none"> ◆ Fill water tank before turning - on - thermostat or connecting appliance to power source. ◆ Use only on a properly protected circuit capable of the rated load. ◆ Electrically ground the chassis. ◆ Follow national/local electrical codes. ◆ Do not use near combustibles.
<p>FAILURE TO COMPLY RISKS EQUIPMENT DAMAGE, FIRE, OR SHOCK HAZARD</p>
<p>READ THE ENTIRE OPERATING MANUAL BEFORE BUYING OR USING THIS PRODUCT</p>
<p>THIS APPLIANCE IS HEATED WHENEVER CONNECTED TO A POWER SOURCE</p> <p style="font-size: small;">00831.0000F 3/98 ©1998 BUNN-O-MATIC CORPORATION</p>

00831.0000

<p>As directed in the International Plumbing Code of the International Code Council and the Food Code Manual of the Food and Drug Administration (FDA), this equipment must be installed with adequate backflow prevention to comply with federal, state and local codes. For models installed outside the U.S.A., you must comply with the applicable Plumbing /Sanitation Code for your area.</p>

00656.0001

⚠ WARNING	
 <p>FUNNEL CONTENTS ARE HOT</p>	<p>DISCARD DECANTER IF:</p> <ul style="list-style-type: none"> • CRACKED • SCRATCHED • BOILED DRY • HEATED WHEN EMPTY • USED ON HIGH FLAME OR EXPOSED ELECTRIC ELEMENTS
<p>READ THE ENTIRE OPERATING MANUAL BEFORE USING THIS PRODUCT</p> <p>FAILURE TO COMPLY RISKS INJURY</p>	
<p>PN: 00658.0000G 02/08 © 1985 BUNN-O-MATIC CORPORATION</p>	

00658.0000



#00824.0002

12364.0000

⚠ CAUTION	WARMERS AND SURFACES ARE HOT
------------------	-------------------------------------

ELECTRICAL REQUIREMENTS

CAUTION - The brewer must be disconnected from the power source until specified in Initial Set-Up.

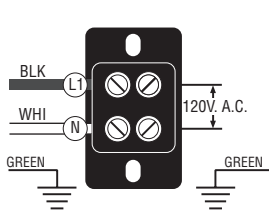

Model 20 requires 2-wire, grounded service rated 120 volts ac, 20 amp, single phase, 60 Hz. Proceed as follows:

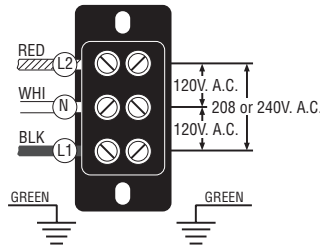

Model 35 requires 3-wire, grounded service rated 120/208 or 120/240 volts ac, 20 amp, single phase, 60 Hz. Proceed as follows:

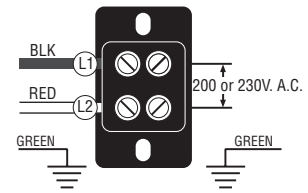

"A" & "B" models require 2-wire, grounded service rated 200 volts ac or 240 volts ac, 20 amp, single phase, 50 Hz. Proceed as follows:

Electrical Hook-Up

CAUTION – Improper electrical installation will damage electronic components.

1. An electrician must provide electrical service as specified.
2. Using a voltmeter, check the voltage and color coding of each conductor at the electrical source.
3. Place the heater switch at the rear of the brewer in the "OFF" lower position.
4. Remove the front panel beneath the sprayhead.
5. Feed the cord through the strain relief and connect it to the terminal block.
6. Connect the brewer to the power source and verify the voltage at the terminal block before proceeding. Replace the front panel.
7. If plumbing is to be hooked-up later be sure the brewer is disconnected from the power source. If plumbing has been hooked-up, the brewer is ready for Initial Set-Up.

CE Requirements:

- This appliance must be installed in locations where it can be overseen by trained personnel.
- For proper operation, this appliance must be installed where the temperature is between 5°C to 35°C.
- Appliance shall not be tilted more than 10° for safe operation.
- An electrician must provide electrical service as specified in conformance with all local and national codes.
- This appliance must not be cleaned by water jet.
- This appliance is not intended for use by persons (including children) with reduced physical, sensory or mental capabilities, or lack of experience and knowledge, unless they have been given instructions concerning use of this appliance by a person responsible for its safety.
- Children should be supervised to ensure they do not play with the appliance.
- If the power cord is ever damaged, it must be replaced by the manufacturer or authorized service personnel with a special cord available from the manufacturer or its authorized service personnel in order to avoid a hazard.
- Machine must not be immersed for cleaning.

PLUMBING REQUIREMENTS

These brewers must be connected to a cold water system with operating pressure between 20 and 90 psi (138 620 kPa) from a ½" or larger supply line. A shut-off valve should be installed in the line before the brewer. Install a regulator in the line when pressure is greater than 90 psi (620 kPa) to reduce it to 50 psi (345 kPa). The water inlet fitting is ¼" flare.

NOTE - Bunn-O-Matic recommends ¼" copper tubing for installations of less than 25 feet and ⅜" for more than 25

PLUMBING REQUIREMENTS (cont.)

feet from the 1/2" water supply line. A tight coil of copper tubing in the water line will facilitate moving the brewer to clean the countertop. Bunn-O-Matic does not recommend the use of a saddle valve to install the brewer. The size and shape of the hole made in the supply line by this type of device may restrict water flow.

As directed in the International Plumbing Code of the International Code Council and the Food Code Manual of the Food and Drug Administration (FDA), this equipment must be installed with adequate backflow prevention to comply with federal, state and local codes. For models installed outside the U.S.A., you must comply with the applicable Plumbing /Sanitation Code for your area.

- 1 Remove shipping cap(s) from the bulkhead fitting(s) on the rear of the brewer.
2. Attach the female flare fitting on the tube from the needle valve to the upper fitting on the rear of the brewer and the female flare fitting on the manifold to the lower fitting on the rear of the brewer.
- 3 Flush the water supply line and securely attach it to the male flare fitting on the manifold.
4. Turn on the water supply.
5. Place an empty vessel beneath the faucet and lift the handle until water is dispensed.

LATE MODELS W/FAUCET

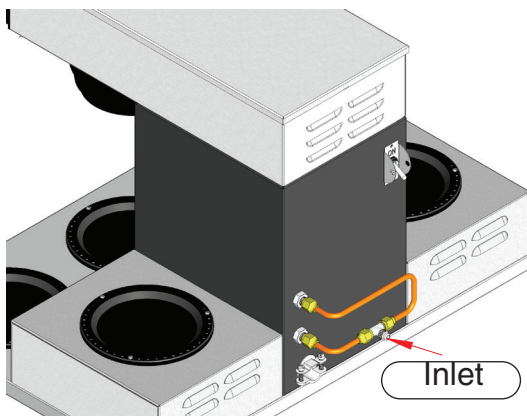

LATE MODELS W/OUT FAUCET

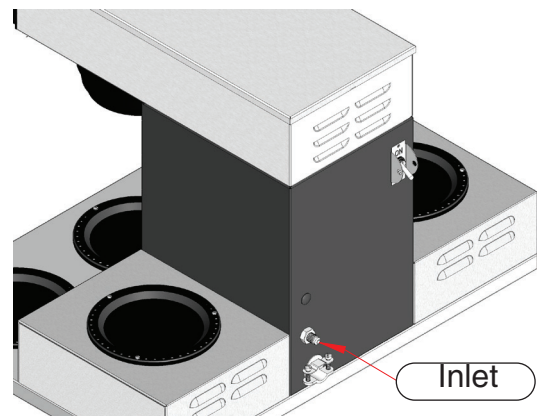

EARLY MODELS W/FAUCET & EXTERNAL FLOW CONTROL

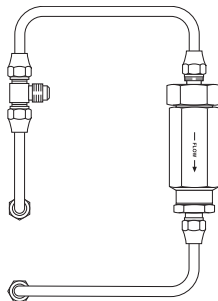

EARLY MODELS W/OUT FAUCET

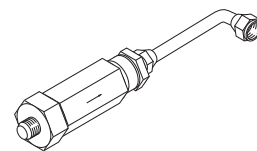

INITIAL SET-UP

CAUTION - The brewer must be disconnected from the power source throughout the initial set-up, except when specified in the instructions.

1. Insert an empty funnel into the funnel rails.
2. Place an empty dispenser under the funnel.
3. Place the heater switch at the rear of the brewer in the "OFF" lower position.
4. Connect the brewer to the power source, place the "ON/OFF" switch in the "ON" upper position, and momentarily press and release the start switch. Water will begin flowing into the tank. When water stops flowing into the tank, initiate a second and a third brew cycle. During the third brew cycle the tank will fill to its capacity and the excess will flow from the sprayhead, out of the funnel, and into the dispenser.
5. When the flow of water from the funnel stops, place the heater switch at the rear of the brewer in the "ON" upper position and wait approximately twenty minutes for the water in the tank to heat to the proper temperature. Some water will drip from the funnel during this time, this is due to expansion and should not occur thereafter.
6. Empty the dispenser and initiate another brew cycle. Place the "ON/OFF" switch in the "ON" upper position, and momentarily press and release the start switch.
7. Place the "ON/OFF" switch in the lower "OFF" position after water has stopped flowing from the funnel, and let the water in the tank reheat to the proper temperature.
8. Empty the dispenser and place the "ON/OFF" switch in the "ON" upper position, and momentarily press and release the start switch. Check the water volume in the dispenser after water has stopped flowing from the funnel. It should be 64 ounces.
9. If not, disconnect the brewer from the power source, remove the front panel, and adjust the brew timer as required. See *Adjusting Brew Volumes*. Replace the front panel, connect the brewer to the power source, and allow the water to reheat, start, and measure another brew cycle.
10. Repeat step 9 until 64 oz water volume is achieved.
11. The brewer is now ready for use in accordance with the coffee brewing instructions on the next page.

ADJUSTING BREW VOLUMES

CAUTION - Disconnect the power source from the brewer prior to the removal of any panel for the replacement or adjustment of any component.

NOTE: Prior to setting or modifying batch sizes, check that the brewer is connected to water supply, the tank is properly filled, and a funnel and server are in place.

1. **Modifying batch sizes.** To modify a batch volume, first check that the SET/LOCK switch is in the "SET" position on the circuit board.

To increase a batch size. Press and hold the START or BREW switch until three clicks are heard. Release the switch (Failure to release the switch within two seconds after the third click causes the volume setting to be aborted and previous volume setting will remain in memory) and press it again one or more times. Each time the switch is pressed, two seconds are added to the brew time period. Allow the brew cycle to finish in order to verify that the desired volume has been achieved.

To decrease a batch size. Press and release the START or BREW switch once for every two-second interval to be removed from the total brew time period; then immediately press and hold down the START or BREW switch until three clicks are heard. Release the switch. (Failure to release the switch within two seconds after the third click causes the volume setting to be aborted and previous volume setting will remain in memory). Allow the brew cycle to finish in order to verify that the desired volume has been achieved.

ADJUSTING BREW VOLUMES(cont)

- Setting batch sizes.** To set a batch volume, first check that the SET/LOCK switch is in the "SET" position on the circuit board. Press and hold the START or BREW switch until three distinct clicks are heard, and then release the switch. (Failure to release the switch within two seconds after the third click causes the volume setting to be aborted and previous volume setting will remain in memory). View the level of the liquid being dispensed. When the desired level is reached, turn the ON/OFF switch to "OFF". The brewer remembers this volume and will continue to brew batches of this size until the volume setting procedure is repeated.
NOTE: When brewing coffee, batch volumes will decrease due to absorption by the coffee grounds.
- Setting programming disable feature.** If it becomes necessary to prevent anyone from changing brew times once programmed, you can set the SET/LOCK switch to the "LOCK" position. This will prevent any programming to be done until switch is once again placed in the "SET" position.

OPERATING CONTROLS

ON/OFF SWITCH

Placing the "ON/OFF" switch in the "OFF" lower position stops brewing. Stopping a brew cycle after it has been started will not stop the flow of water into the funnel until the tank syphons down to its proper level. Placing the switch in the "ON" upper position supplies power to the brew station warmer and enables the brew circuit.

START SWITCH

Momentarily pressing and releasing the switch starts a brew cycle when the "ON/OFF" switch is in the "ON" upper position.

NOTE – The "ON/OFF" switch must be in the "ON" upper position to initiate and complete a brew cycle.

COFFEE BREWING

- Insert a BUNN® filter into the funnel.
- Pour the fresh coffee into the filter and level the bed of grounds by gently shaking.
- Slide the funnel into the funnel rails.
- Place an empty dispenser beneath the funnel.
- Place the "ON/OFF" switch in the "ON" upper position. Momentarily press and release the start switch.
- When brewing is completed, simply discard the grounds and filter.

CLEANING

- The use of a damp cloth rinsed in any mild, non-abrasive, liquid detergent is recommended for cleaning all surfaces on Bunn-O-Matic equipment.
- Check and clean the sprayhead. The sprayhead holes must always remain open.
- With the sprayhead removed, insert the delimiting spring (provided) all the way into the sprayhead tube. When inserted properly, no more than two inches of spring should be visible. Saw back and forth five or six times.

NOTE – In hard water areas, this may need to be done daily. It will help prevent liming problems in the brewer and takes less than a minute.