

## **SERVICE MANUAL**

### **BUNN-O-MATIC CORPORATION**

POST OFFICE BOX 3227  
SPRINGFIELD, ILLINOIS 62708-3227  
PHONE: (217) 529-6601 FAX: (217) 529-6644

To ensure you have the latest revision of the Operating Manual, Illustrated Parts Catalog, Programming Manual, or Service Manual, please visit the Bunn-O-Matic website, at [www.bunn.com](http://www.bunn.com). This is absolutely FREE, and the quickest way to obtain the latest catalog and manual updates. For Technical Service, contact Bunn-O-Matic Corporation at 1-800-286-6070.

Warranty statements and information can be found on our website. Please visit <https://commercial.bunn.com/support/warranty-lookup> for further details.

## **Contents**

Circuit Breaker .....	10
Fuse and Fuse Holder .....	11
Contactor .....	12
Control Thermostat.....	14
Limit Thermostat.....	16
Thermal Cut-off .....	17
Tank Heater(s).....	18
Liquid Level Board and Level Probe .....	20
Digital Timer (Late Models).....	22
Timer (Early Models).....	24
Pump .....	26
Relay .....	30
Solenoid .....	32
Transformer .....	34
Master ON/OFF Switch (Late Models) .....	35
ON/OFF Switch.....	36
Start Switch (Brew).....	38
Selector Switch (Half Batch) .....	40
Schematic Wiring Diagrams.....	42 thru 58

## TROUBLESHOOTING

A troubleshooting guide is provided to suggest probable causes and remedies for the most likely problems encountered. If the problem remains after exhausting the troubleshooting steps, contact the Bunn-O-Matic Technical Service Department.

- Inspection, testing, and repair of electrical equipment should be performed only by qualified service personnel.
- All electronic components have 120 volt ac and low voltage dc potential on their terminals. Shorting of terminals or the application of external voltages may result in board failure.
- Intermittent operation of electronic circuit boards is unlikely. Board failure will normally be permanent. If an intermittent condition is encountered, the cause will likely be a switch contact or a loose connection at a terminal or crimp.
- Solenoid removal requires interrupting the water supply to the valve. Damage may result if solenoids are energized for more than ten minutes without a supply of water.
- The use of two wrenches is recommended whenever plumbing fittings are tightened or loosened. This will help to avoid twists and kinks in the tubing.
- Make certain that all plumbing connections are sealed and electrical connections tight and isolated.
- This brewer is heated at all times. Keep away from combustibles.

- WARNING** –
- Exercise extreme caution when servicing electrical equipment.
  - Unplug the brewer when servicing, except when electrical tests are specified.
  - Follow recommended service procedures
  - Replace all protective shields or safety notices

<b>PROBLEM</b>	<b>PROBABLE CAUSE</b>	<b>REMEDY</b>
Brew cycle will not start	1. No water	Water lines and valves to the brewer must be open.
	2. No power or incorrect voltage to the brewer	(A1) Check the terminal block for 120 volts ac across the red and white terminals and the black and white terminal on three wire 102/208 volt or 120/240 volt models. (A2) Check the terminal block for 208 volts ac, 230 volts ac or 240 volts ac on "A Series" brewers across the red and black terminals on two wire single phase 208 volt, 230 volt and 240 volt models. (A3) Check the terminal block for 208 volts ac, 240 volts ac, 380 volts ac across the black and blue terminals, the blue and red and the black and red terminals on three wire three phase 208 volt, 240 volt and 380 volt models.

## TROUBLESHOOTING (cont.)

### PROBLEM

### PROBABLE CAUSE

### REMEDY

Brew cycle will not start (cont)

2. No power or incorrect voltage to the brewer (cont)

(A4) Check the terminal block for 440 volts ac across the black and blue terminals, black and red terminals and the red and blue terminals on four wire three phase 440 volt models.  
(B) Check circuit breakers or fuses.

3. Water level below pump housing. (Water level in the hot water gauge glass should be approximately half full).

Be sure water shut-off valve is open and that the in-line filters or strainers are not blocking water flow. (Do not confuse water shut-off valve with the manual fill and drain valve underneath the brewer).

Refer to Service - ON/OFF Switch for testing. See page 22

4. ON/OFF Switch

Refer to Service - Start Switches for testing procedures. See page 29

5. Start Switch

Refer to Service - Relay for testing procedures. See page 24

6. Relay

Refer to Service - Timer for testing procedures. See page 31 or 33

7. Timer

Refer to Service - Pump for testing procedures. See page 23

8. Pump

Refer to Service - Solenoid Valve for testing procedures. See page 27

9. Solenoid Valve

(A) Direction of flow arrow must be pointing towards brewer.

10. Strainer

(B) Remove the strainer and check for obstructions. Clear or replace.

Refer to Service - Relay for testing procedures. See page 24

Brew cycle starts with brew lockout relay engaged.

1. Relay

## TROUBLESHOOTING (cont.)

### PROBLEM

### PROBABLE CAUSE

### REMEDY

Tank not filling

1.ON/OFF Switch (This switch must be in the "ON" position for the refill circuit to operate.

Refer to Service - ON/OFF Switch for testing procedures. See page 22

2. No water

Be sure water shut-off is open and that in-line filters or strainers are not blocking water flow. (Do not confuse water shut-off valve with the manual fill and drain valve underneath brewer).

3. Solenoid Valve

Refer to Service - Solenoid Valve for testing procedures. See page 27

4. Probe

Refer to Service - Probe for testing procedures. See page 20

5. Liquid Level Board

Refer to Service - Liquid Level Board for testing procedures. See page 20

Water running out of the overflow

1.Brewer not level

Brewer must be level and installed on a sturdy structure.

2. Solenoid Valve

Refer to Service - Solenoid Valve for testing procedures. See page 27

3. Liquid Level Board

Refer to Service -Liquid Level Board for testing procedures. See page 20

4. Probe

Refer to Service - Probe for testing procedures. See page 20

5. Manual fill and drain valve underneath brewer open.

Be sure valve is closed.

## TROUBLESHOOTING (cont.)

PROBLEM	PROBABLE CAUSE	REMEDY
Water not hot	1. Limit Thermostat <b>CAUTION</b> - Do not eliminate or bypass limit thermostat. Use only Bunn-O-Matic replacement part #29329.1000	Refer to Service - Limit Thermostat for testing procedures. See page 19
	2. Control Thermostat	Refer to Service - Control Thermostat for testing procedures. See page 17
	3. Tank Heater(s)	Refer to Service - Tank Heater for testing procedures. See page 30
	4. Contactor	Refer to Service - Contactor for testing procedures. See page 15
Circuit breaker keeps tripping	1. Circuit Breaker	Refer to Service - Circuit Breaker for testing procedures. See page 14
	2. Tank Heater(s)	Refer to Service - Tank Heater for testing procedures. See page 30
Water keeps running from swing spout	1. Timer	Refer to Service - Timer for testing procedures. See page 31 or 33
	2. Start Switch	Refer to Service - Start Switch for testing procedures. See page 29
Inconsistent coffee yield	1. Timer	Refer to Service - Timer for testing procedures. See page 31 or 33
	2. Solenoid Valve	Refer to Service - Solenoid Valve for testing procedures. See page 27
	3. Lime build-up in swing spout and pump tubing.	Remove swing spout and insert delimiting rod down into pump tubing as far as possible.
Funnels overflow	1. Filters	Use Bunn® filters made for the U3 brewer.
	2. Hole in bottom of funnel obstructed.	Remove obstruction.

## TROUBLESHOOTING (cont.)

### PROBLEM

### PROBABLE CAUSE

### REMEDY

Funnels overflow (cont.)

3. Pump - Flow Rate

Check pump flow rate with a watch. Pump flow rate should be approximately 24 ounces in 15 seconds. Be sure pump assembly is free of any obstructions.

4. Soft Water

When using a water softener, a coarse grind of coffee may be preferred. If required, a bypass system is available as an optional feature.

Coffee reservoir overflows

1. Coffee reservoir not completely empty before a brew cycle was started.

Be sure coffee reservoir is empty before brew cycle is started.

2. Timer

Refer to Service-Timer for testing procedures. See page 31 or 33

3. Pump - Flow Rate

Check pump flow rate with a watch. Pump flow rate should be approximately 24 ounces in 15 seconds. Be sure pump assembly is free of any obstructions.

Brewer is making unusual noises

1. Solenoid Valve

The nut on the solenoid must be tight or it will vibrate during operation.

2. Plumbing lines

Plumbing lines should not be resting on the counter top.

3. Water supply

(A) The brewer must be connected to a cold water line.

(B) Water pressure to the brewer must not exceed 90 psi (620 kPa). Install a regulator if necessary to lower the pressure to approximately 50 psi (345 kPa).

4. Tank Heater(s)

Remove and clean lime off the tank heater. See page 30

This section provides procedures for testing and replacing various major components used in this brewer should service become necessary. Refer to **Troubleshooting** for assistance in determining the cause of any problem.

**WARNING** - Inspection, testing, and repair of electrical equipment should be performed only by qualified service personnel. The brewer should be unplugged when servicing, except when electrical tests are required and the test procedure specifically states to plug in the brewer.

### COMPONENT ACCESS - U3

**WARNING** - Disconnect the brewer from the power source before the removal of any panel or the replacement of any component.

All components are accessible by the removal of the swing spout, front cupola cover, rear cupola cover and the cupola.

Disconnect the swing spout nut from the swing spout base fitting. Remove swing spout.

Remove the four #8-32 screws, two on the front and rear, securing front and rear cupola covers to the cupola.

Slip cupola off of the component bracket.

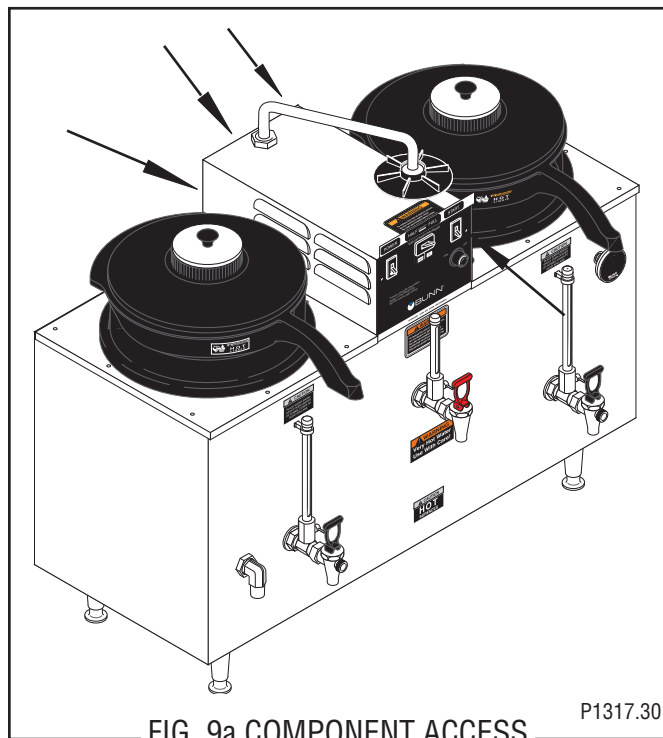

FIG. 9a COMPONENT ACCESS

### COMPONENT ACCESS - SRU

**WARNING** - Disconnect the brewer from the power source before the removal of any panel or the replacement of any component.

The control thermostat, limit thermostat, pump, solenoid valve, liquid level probe and tank heater are accessible by removal of the swing spout, front cupola cover, rear cupola cover and the cupola.

Disconnect the swing spout nut from the swing spout base fitting. Remove swing spout.

Remove the four #8-32 screws, two on each side, securing the side covers to the cupola.

Slip cupola off of the component bracket.

The on/off switch, selector switch, start switch, timer, contactor and liquid level control board are accessible by removal of the front lower panel.

Remove the four #8-32 screws securing the front access panel to the base.

The circuit breaker, fuse and fuse holder are accessible by removal of the rear utility cover.

Remove the six #8-32 screws securing the rear utility cover to the housing.

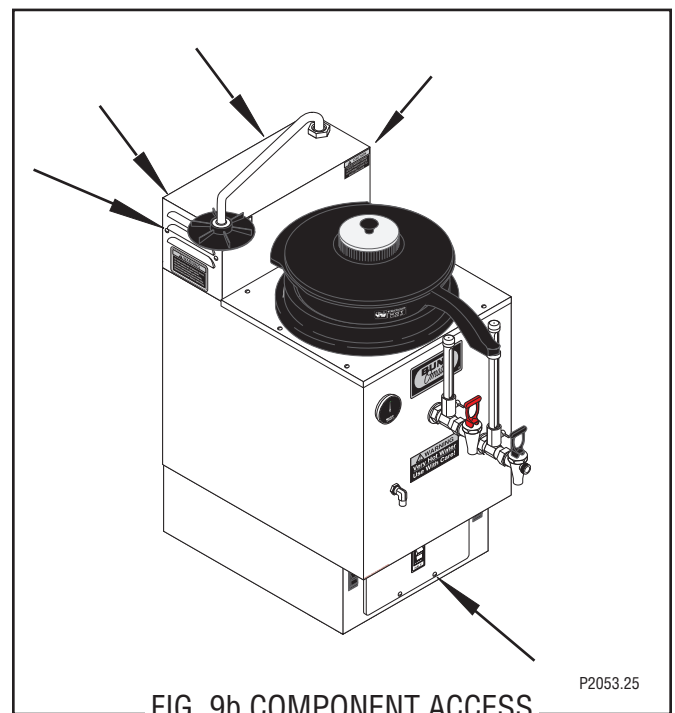

FIG. 9b COMPONENT ACCESS

## CIRCUIT BREAKER (120/208V and 120/240V Three Wire Models and 440V Four Wire Models)

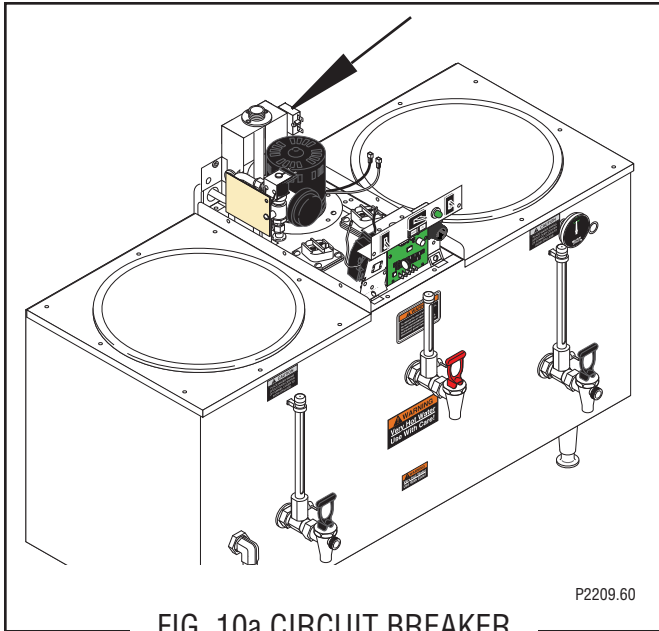

FIG. 10a CIRCUIT BREAKER

### Location: U3

The circuit breaker is located on the right rear of the component bracket.

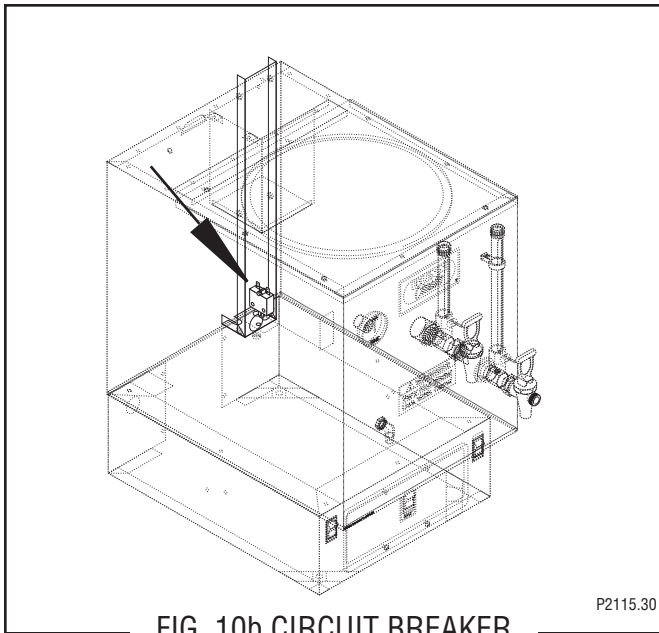

FIG. 10b CIRCUIT BREAKER

### Location: SRU

The circuit breaker is located on the rear of the urn, behind the rear utility cover.

### Test Procedures:

1. Disconnect the brewer from the power source.
2. Disconnect the black wire from the main harness from the circuit breaker and the white wire on the

pump assembly. With a voltmeter, check the voltage across the black wire and the white wire. Connect the brewer to the power source. The indication must be:

- a) 120 volts ac for three wire 120/208 volt and 120/240 volt models.
- b) 208 or 240 volts ac for four wire 440 volt models.

3. Disconnect the brewer from the power source.

If voltage is present as described, reconnect the white wire to the pump assembly and proceed to #4. If voltage is not present as described, refer to the **Wiring Diagrams** and check the brewer wiring harness.

4. With the black wire removed, remove the other black wire from the circuit breaker.
5. Check for continuity across the terminals on the circuit breaker.

If continuity is present as described the circuit breaker is operating properly.

If continuity is not present as described, press the reset button and repeat step 5, if continuity is not present as described, replace the circuit breaker.

### Removal and Replacement:

1. Remove wires from the circuit breaker.
2. Remove the nut securing the circuit breaker to the component bracket.
3. Remove circuit breaker and discard.
4. Install new circuit breaker on component bracket and secure with nut.
5. Refer to Fig. 10c and reconnect the wires.

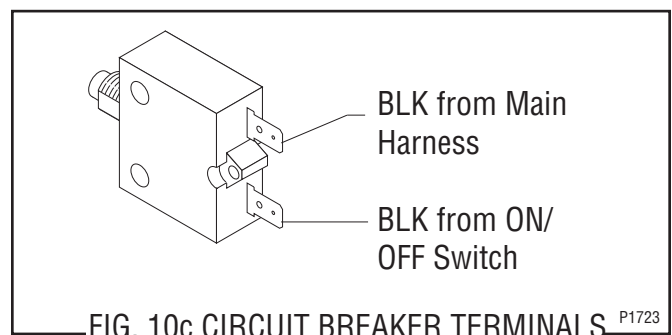

FIG. 10c CIRCUIT BREAKER TERMINALS

**FUSE AND FUSE HOLDER (208V, 240V, 230V Two Wire Models and 380V Three Wire Models)**

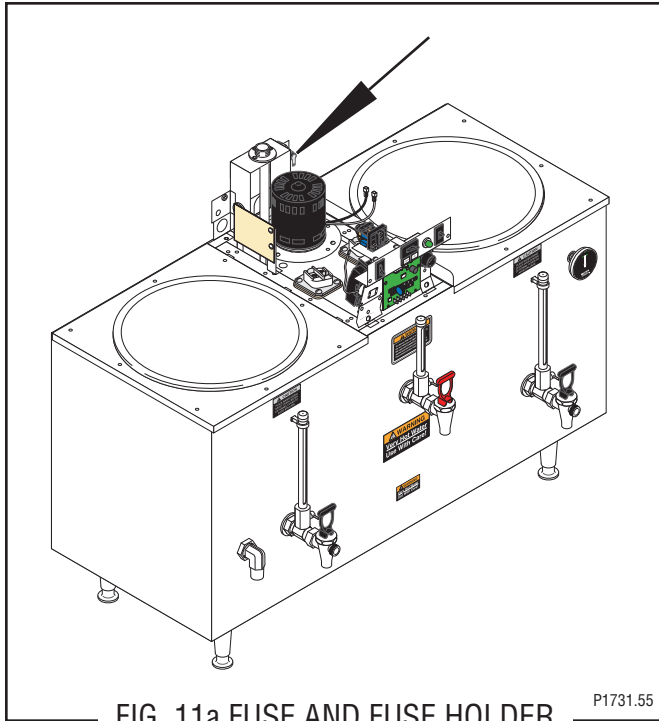

FIG. 11a FUSE AND FUSE HOLDER

P1731.55

Location: U3

The fuse and fuse holder are located on the right rear of the component bracket.

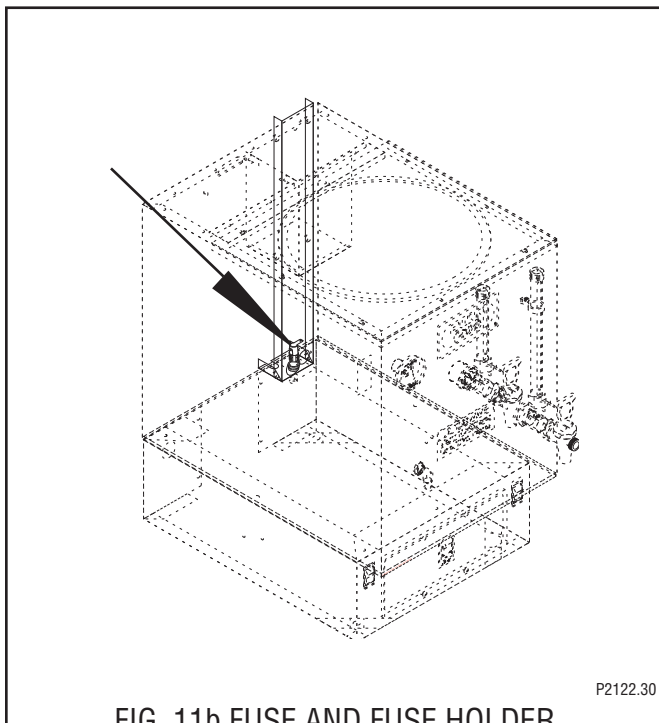

FIG. 11b FUSE AND FUSE HOLDER

P2122.30

Location: SRU

The fuse and fuse holder are located on the rear of the urn behind the rear utility cover.

Test Procedures:

1. Disconnect the brewer from the power source.
2. Remove the cap and fuse from the fuse holder.
3. Remove fuse from the cap.
4. Check for continuity through the fuse.

If continuity is present as described, reinstall the fuse, the fuse is operating properly.

If continuity is not present as described replace the fuse.

Removal and Replacement:

Fuse:

1. Remove the cap from the fuse holder.
2. Remove fuse from the fuse holder, inspect, if blown discard.
3. Install new 5 amp fuse in the fuse holder.
4. Reinstall fuse holder cap.

Fuse Holder:

1. Disconnect the wires from the rear of the fuse holder.
2. Remove the nut securing the fuse holder to the component bracket.
3. Push fuse holder through the hole in the component bracket.
4. Install new fuse holder and fuse through the hole in the component bracket and secure with nut.
5. Refer to Fig. 11c and reconnect the wires.

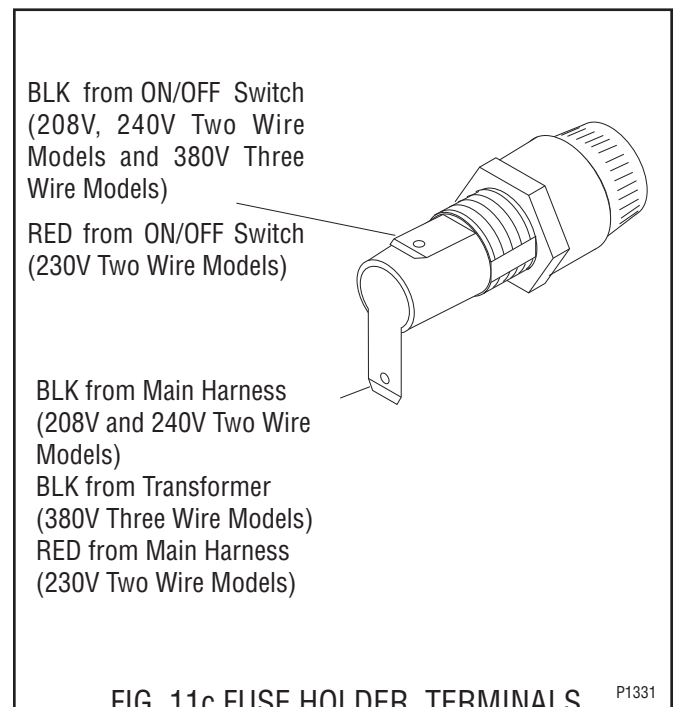

FIG. 11c FUSE HOLDER TERMINALS

P1331

## CONTACTOR

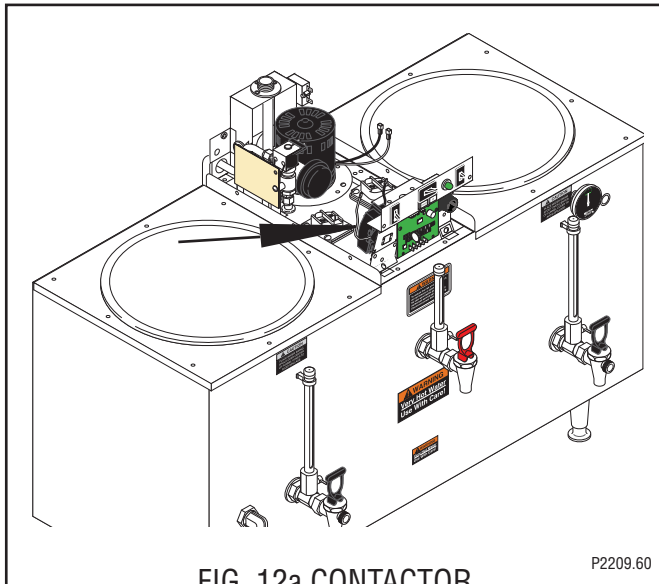

FIG. 12a CONTACTOR

### Location: U3

The contactor is located on the left front of the component bracket.

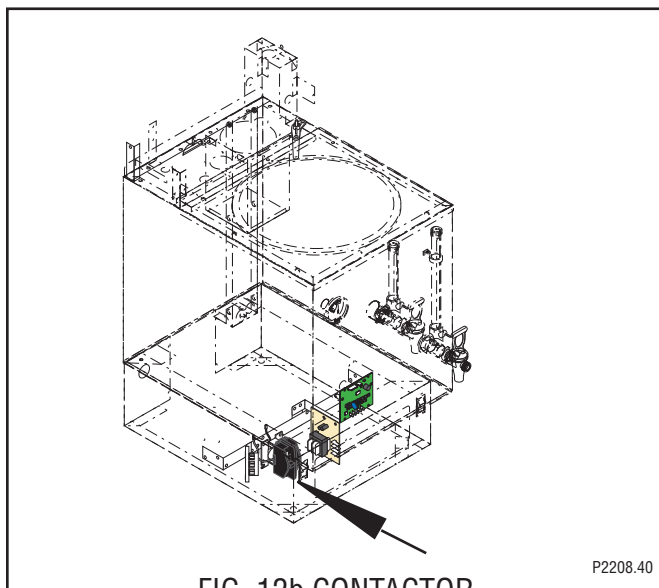

FIG. 12b CONTACTOR

### Location: SRU

The contactor is located inside the front lower access panel, left of center on the component bracket.

### Test Procedures:

1. Disconnect the brewer from the power source.
- 2A. 120/208V, 120/240V, 380V THREE WIRE MODELS, 380V and 440V FOUR WIRE MODELS  
Disconnect the black wire from the contactor coil to the limit thermostat and black wire from the white wire on the main harness.

### 2B. 208V or 240V TWO WIRE MODELS (Prior to # U300004095), 208V and 240V THREE WIRE MODELS

Disconnect the black wire from the contactor coil to the limit thermostat and black wire from the red wire on the main harness.

### 2C. 230V MODELS (S/N U300004095 - UP)

Disconnect the red wire from contactor coil to the limit thermostat and the black wire from the main harness.

3. Connect the brewer to the power source.
4. Check the voltage across the coil wire and the wire from the main harness. The indication must be:
  - a) 120 volts ac for three wire 120/208, 120/240 volt and 380 volt models.
  - b) 230 volts ac for two wire 230 volt models.
  - c) 208 or 240 volts ac for two wire 208 or 240 volt models.
  - d) 220 or 254 volts ac for four wire 280 or 440 volt models.

5. Disconnect the brewer from the power source.

If voltage is present as described, proceed to #6.  
If voltage is not present as described refer to the Wiring Diagrams and check the brewer wiring harness.

6. Check for continuity between the black leads on the contactor coil or the left and right terminals on the contactor coil on 230V models.

If continuity is present as described, reconnect the wires and proceed to #7.

If continuity is not present as described, replace the contactor.

7. On all brewers, with a voltmeter, check the voltage across the upper left terminal and the upper right terminal on the contactor. Connect the brewer to the power source. The indication must be:
  - a) 120 volts ac for three wire 120/208, 120/240 volt and 380 volt models.
  - b) 230 volts ac for two wire 230 volt models.
  - c) 208 or 240 volts ac for two wire 208 or 240 volt models.
  - d) 220 or 254 volts ac for four wire 280 or 440 volt models.
8. Disconnect the brewer from the power source.

## CONTACTOR (cont.)

If voltage is present as described, proceed to #9.  
If voltage is not present as described, refer to the **Wiring Diagrams** and check the brewer wiring harness.

9. Check for continuity across the terminals on the left side of the contactor by manually closing the contacts. Continuity must not present when the contact is released.
10. Check for continuity across the terminals on the right side of the contactor by manually closing the contacts. Continuity must not be present when the contact is released.

If continuity is present as described, the contactor is operating properly.

If continuity is not present as described, replace the contactor.

### Removal and Replacement:

1. Disconnect all the wires from the contactor.
2. Remove the two #8-32 screws securing the contactor to the contactor mounting bracket, remove contactor and protective shield. Discard contactor.
3. Install new contactor with shield between mounting bracket and contactor and secure with two #8-32 screws
4. Refer to Fig. 13a and reconnect the wires.

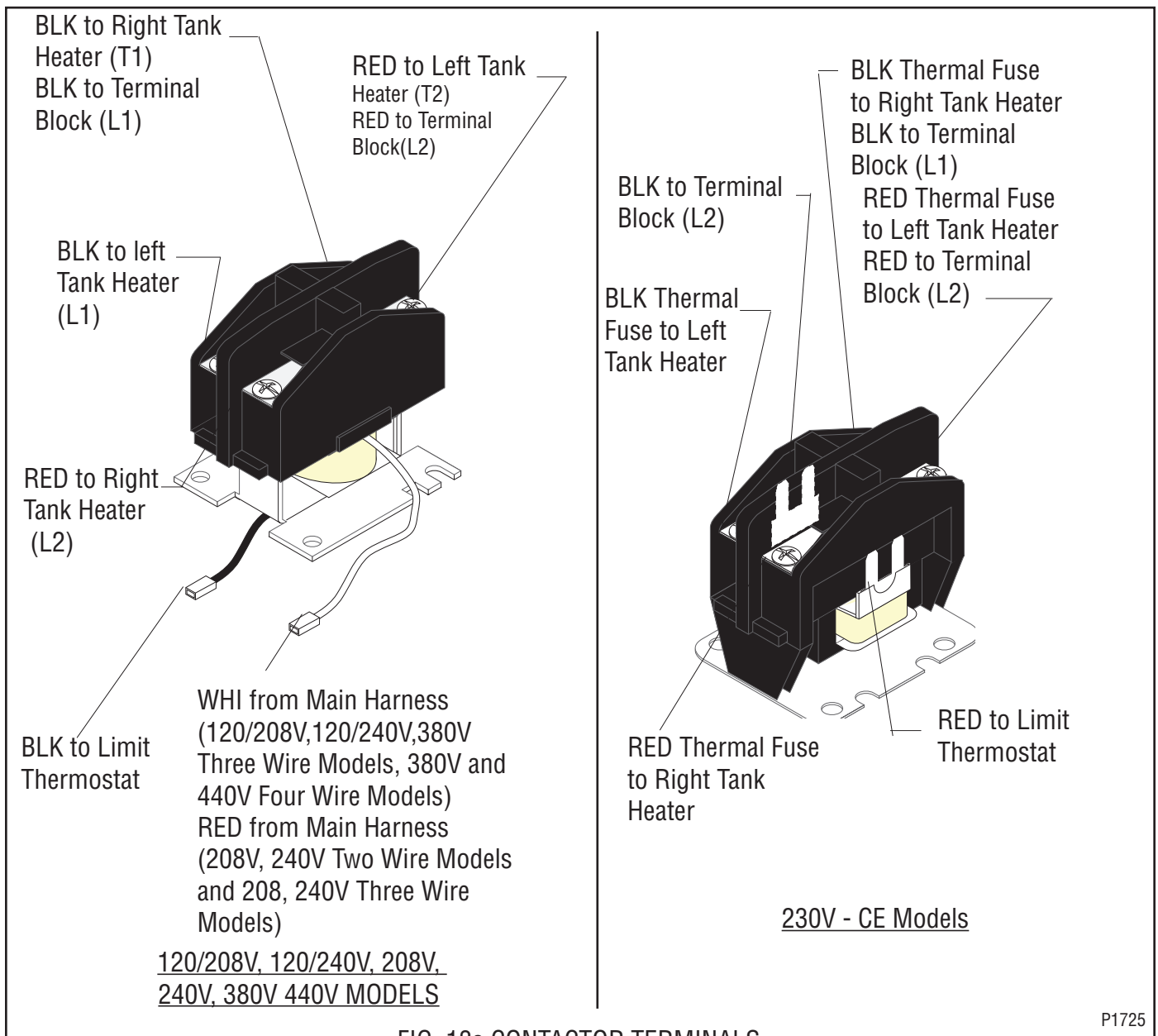

FIG. 13a CONTACTOR TERMINALS

P1725

## CONTROL THERMOSTAT

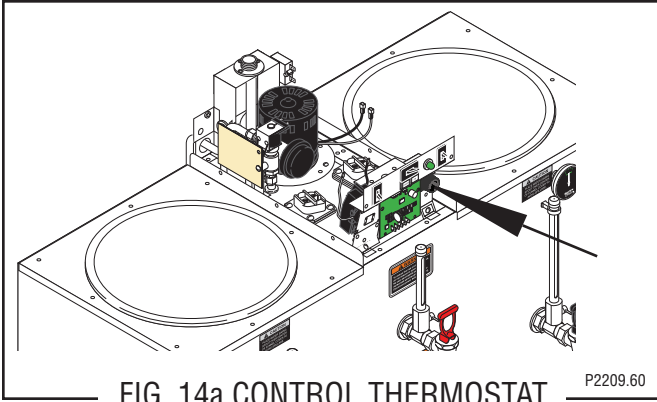

FIG. 14a CONTROL THERMOSTAT

### Location: U3

The control thermostat is mounted on the right front of the component bracket.

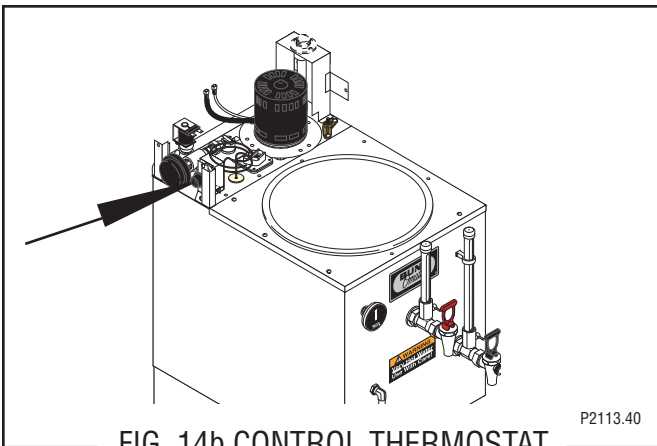

FIG. 14b CONTROL THERMOSTAT

### Location: SRU

The control thermostat is mounted on the left front of the top component bracket.

### Test Procedures:

1. Disconnect the brewer from the power source.
2. Locate the thermostat and the voltage check points.
3. Connect the brewer to the power source.

### Model

	<u>Check Voltage Across</u>	<u>Voltage</u>
120/208V & 120 240V - 3 wire w/ ground single phase	Black wire on thermostat from main harness to white wire in terminal block.	120V
230V - 2 wire w/ ground single phase	Red wire on thermostat from main harness to black wire in terminal block.	230V
208V or 240V - 2 wire w/ground single phase	Black wire on thermostat from main harness to red wire in the terminal block.	208V or 240V
280V or 440V - 4 wire w/ground 3 phase	Black wire on thermostat from main harness to white wire in terminal block.	220V or 254V
380V - 3 wire w/ ground 3 phase w/ stepdown transformer	Black wire on thermostat from main harness to white wire on step down trans- former.	120V

4. Disconnect the brewer from the power source. If voltage is present as described, proceed to #5. If voltage is not present as described, refer to the **Wiring Diagrams** and check the brewer wiring harness.

5. Disconnect the black wires from the control thermostat.
6. Check for continuity across the terminals on the control thermostat with the control thermostat in the "ON" position (fully clockwise), continuity must not be present when the thermostat is in the "OFF" position (fully counterclockwise).

If continuity is present as described, the control thermostat is operating properly.

If continuity is not present as described, replace the control thermostat.

### Removal and Replacement:

1. Disconnect the wires from the control thermostat.
2. Remove the thermostat capillary bulb by firmly pulling up on the capillary at the component bracket. This will disengage the grommet from the component bracket.
3. Remove the #8-32 screw securing the control thermostat and mounting bracket to the component bracket. Remove control thermostat and bracket as an assembly.
4. Remove knob from control thermostat.
5. Remove the two #6-32 screws securing the control thermostat to the thermostat mounting bracket. Remove and discard thermostat.
6. Install new control thermostat on thermostat mounting bracket and secure with two #6-32 screw.
7. Install knob on thermostat.

## CONTROL THERMOSTAT (cont.)

8. Install thermostat and mounting bracket on the component bracket and secure with one #8-32 screw.
9. Carefully bend the capillary tube so that the tube and bulb inside the brewer are in the vertical position.

**NOTE:** The capillary tube must be clear of any electrical termination and not kinked.

10. Refer to Fig. 7 and reconnect the wires.
11. Adjust the control thermostat as required.

### Removal and Replacement:

1. Disconnect the wires from the control thermostat.
2. Remove the thermostat capillary bulb by firmly pulling up on the capillary at the component bracket. This will disengage the grommet from the component bracket.
3. Remove the #8-32 screw securing the control thermostat and mounting bracket to the component bracket. Remove control thermostat and bracket as an assembly.
4. Remove knob from control thermostat.
5. Remove the two #6-32 screws securing the control thermostat to the thermostat mounting bracket. Remove and discard thermostat.
6. Install new control thermostat on thermostat mounting bracket and secure with two #6-32 screw.
7. Install knob on thermostat.
8. Install thermostat and mounting bracket on the component bracket and secure with one #8-32 screw.
9. Carefully bend the capillary tube so that the tube and bulb inside the brewer are in the vertical position.

**NOTE:** The capillary tube must be clear of any electrical termination and not kinked.

10. Refer to Fig. 15a and reconnect the wires.
11. Adjust the control thermostat as required.

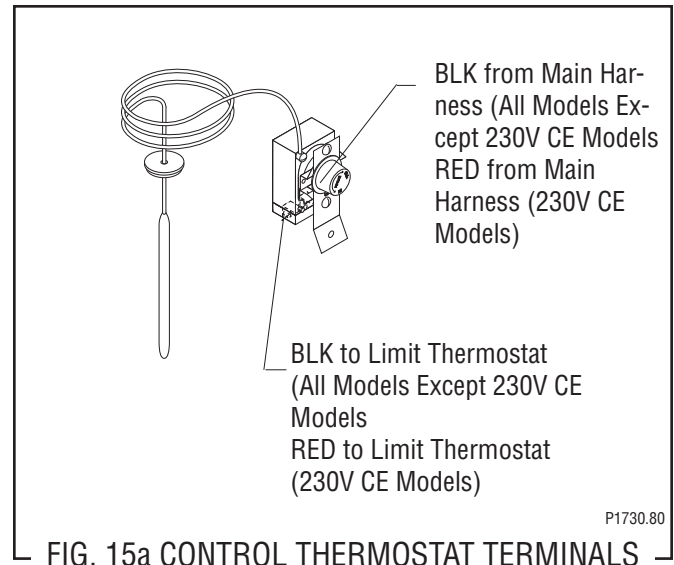
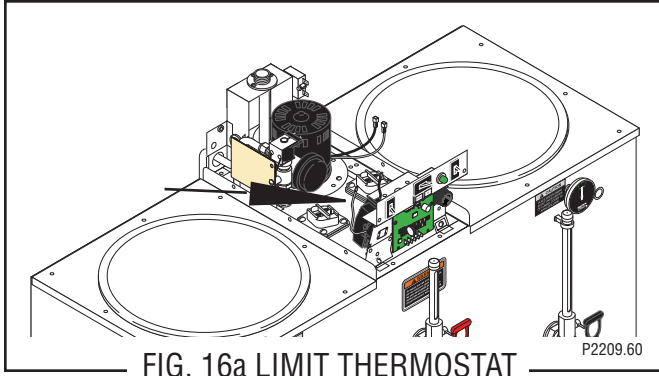

FIG. 15a CONTROL THERMOSTAT TERMINALS

## LIMIT THERMOSTAT



### Location: U3

The limit thermostat is located on the center front of the component bracket behind the timer mounting bracket.

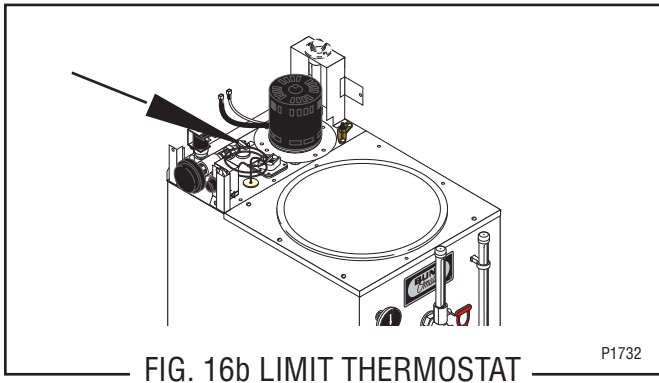

### Location: SRU

The limit thermostat is located on the center rear of the component bracket behind the tank heater.

### Test Procedures:

1. Disconnect the brewer from the power source.
2. Disconnect the black wires or the red wires from the limit thermostat.
3. With an ohmmeter, check for continuity across the limit thermostat terminals.

If continuity is present as described, the limit thermostat is operating properly.

If continuity is not present as described, replace the limit thermostat.

### Removal and Replacement:

1. Remove the wires from the limit thermostat terminals.
2. Carefully slide the limit thermostat out from under the retaining clip and remove the limit thermostat.
3. Carefully slide the new limit thermostat into the retaining clip.
4. Refer to Fig. 16c and reconnect the wires.

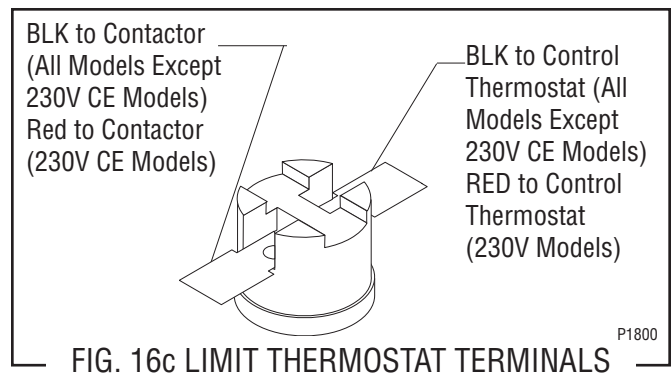

## THERMAL FUSES (230V-CE MODELS ONLY)

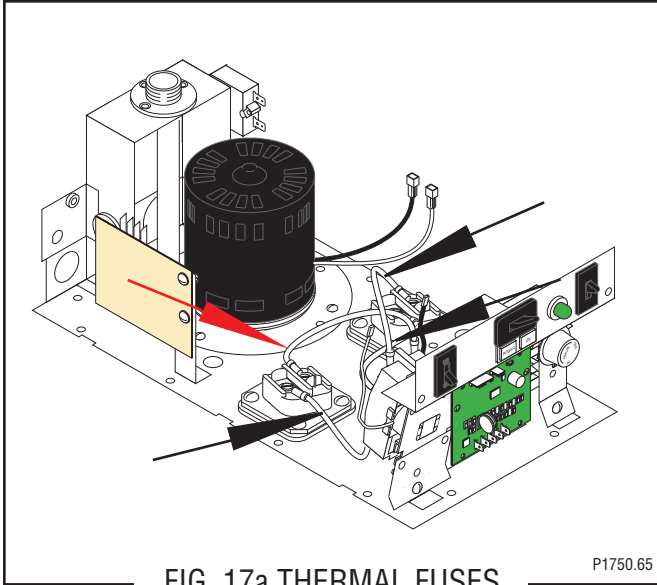

FIG. 17a THERMAL FUSES

P1750.65

### Location: U3

The thermal fuses are mounted on the tank heater terminals and the contactor terminals.

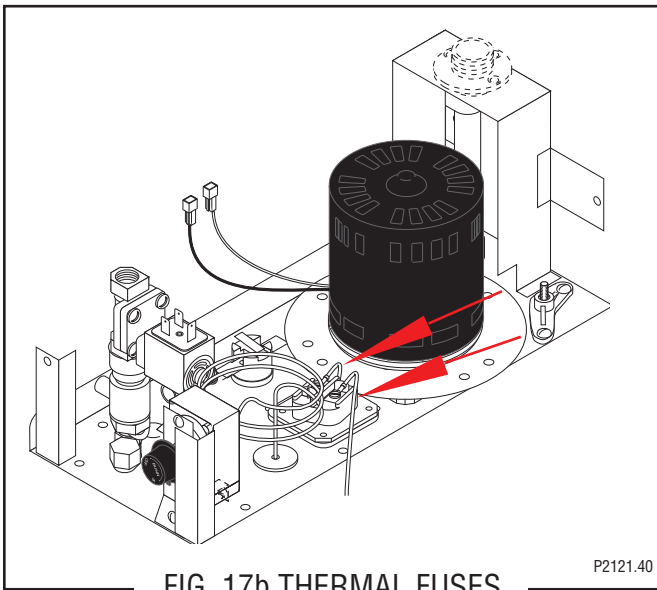

FIG. 17b THERMAL FUSES

P2121.40

### Location: SRU

The thermal fuses are mounted on the tank heater terminals.

### Test Procedures:

1. Disconnect the brewer from the power source.
2. Disconnect the thermal fuse from the tank heater terminal and the contactor terminal.
3. Check for continuity across the terminals on the ends of the thermal fuse.

If continuity is present as described, the thermal is operating properly.

If continuity is not present as described, replace the thermal fuse.

### Removal and Replacement:

1. Disconnect the thermal fuse from the tank heater terminal and the contactor and discard.
2. Connect the new thermal fuse to the tank heater terminal and the contactor terminal.

## TANK HEATERS

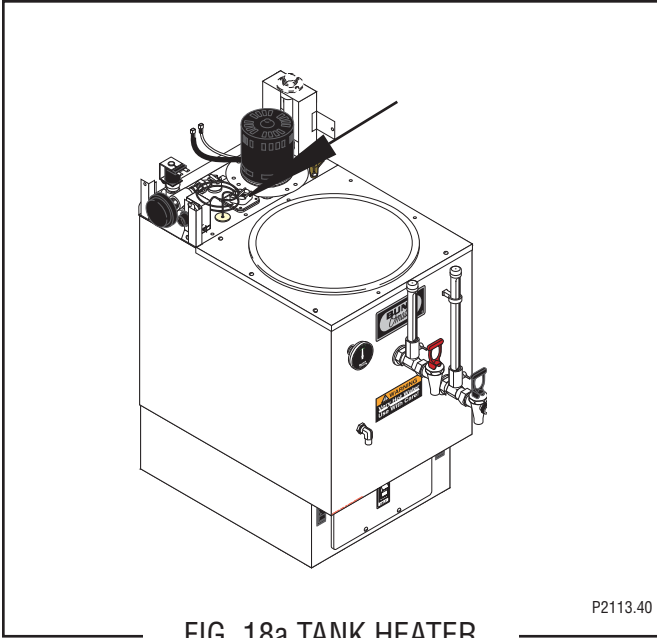

FIG. 18a TANK HEATER

Location: SRU

The tank heater is located on the front center of the upper component bracket.

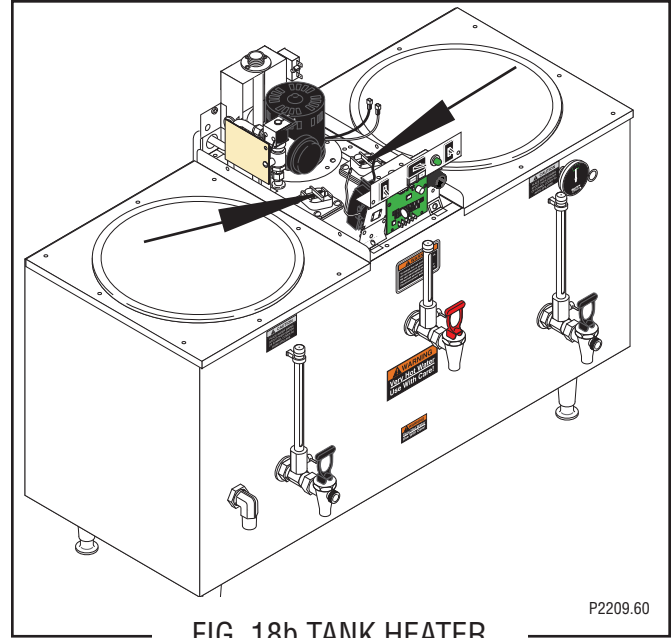

FIG. 18b TANK HEATER

Location: U3

The tank heaters are located on the right center and the left center of the component bracket.

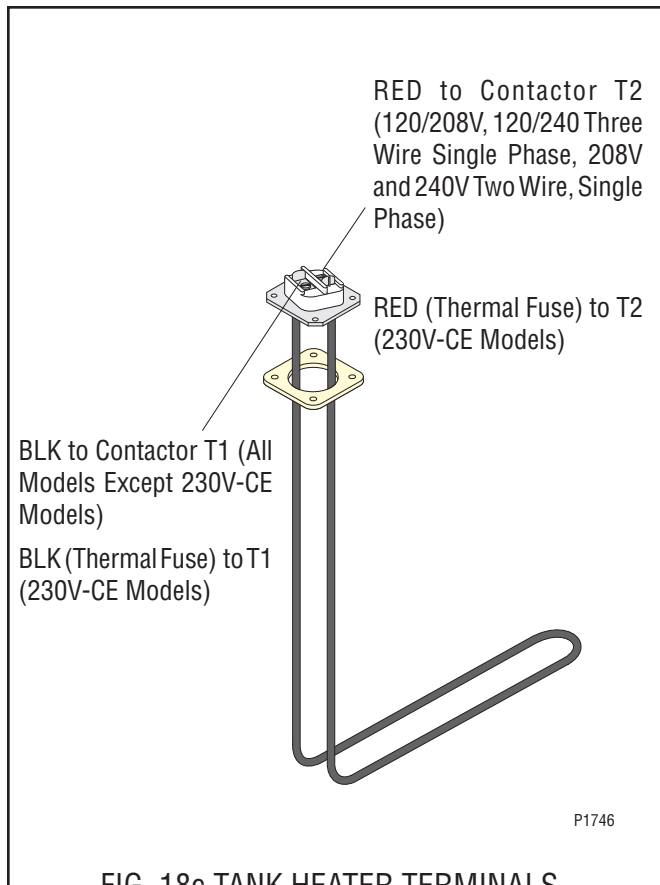

FIG. 18c TANK HEATER TERMINALS

### Test Procedures:

1. Disconnect the brewer from the power source.
2. Disconnect the wires from the tank heater.
3. Check for resistance across the tank heater terminals. **Refer to chart.**
4. Check for continuity from each tank heater terminal to the metal sheath or mounting flange.

If resistance/continuity is present as described, heater is working.

If resistance/continuity is not present as described, replace the tank heater.

## TANK HEATERS (cont.)

HEATER	RESISTANCE
2875W-208V	14.05-16.39 $\Omega$
3325W-240V	16.20-19.25 $\Omega$
3950W-208V	10.23-11.93 $\Omega$
3950W-240V	13.62-15.89 $\Omega$
3950W-380V	34.14-39.82 $\Omega$
3950W-440V	45.77-53.39 $\Omega$
6000W-208V	6.74- 7.85 $\Omega$
6000W-240V	8.95-10.45 $\Omega$
TERMINAL TO SHEATH - INFINITE (OPEN)	

### Removal and Replacement:

1. Remove the wires or thermal fuses from the tank heater.
2. Remove the four #8-32 screws securing the tank heater to the component bracket.
3. Remove tank heater and gasket.
4. Position new tank heater and gasket on the component bracket and secure with four #8-32 screws.
5. Refer to Fig. 18c/19a and reconnect the wires.

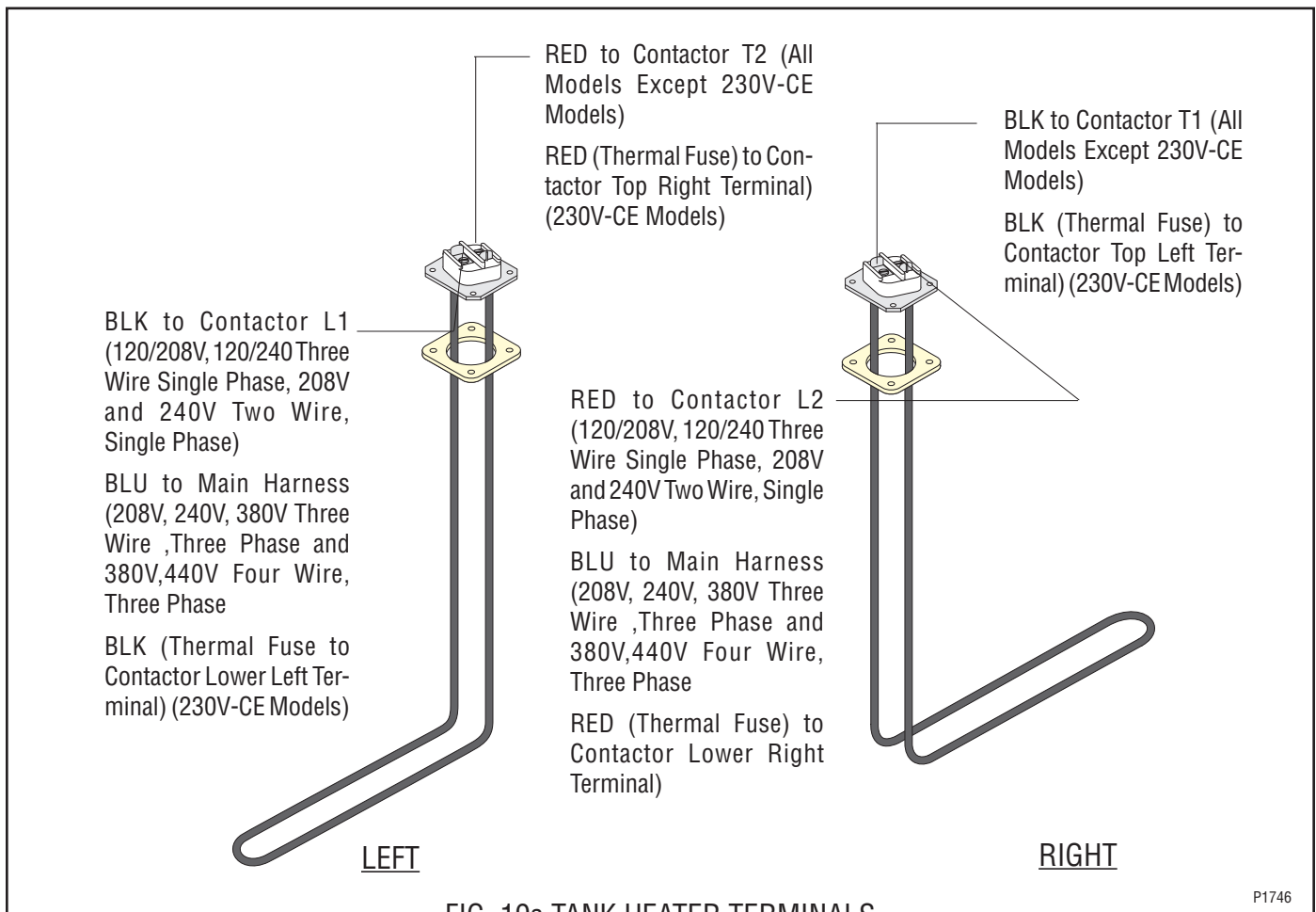

FIG. 19a TANK HEATER TERMINALS

P1746

## LIQUID LEVEL BOARD AND LEVEL PROBE

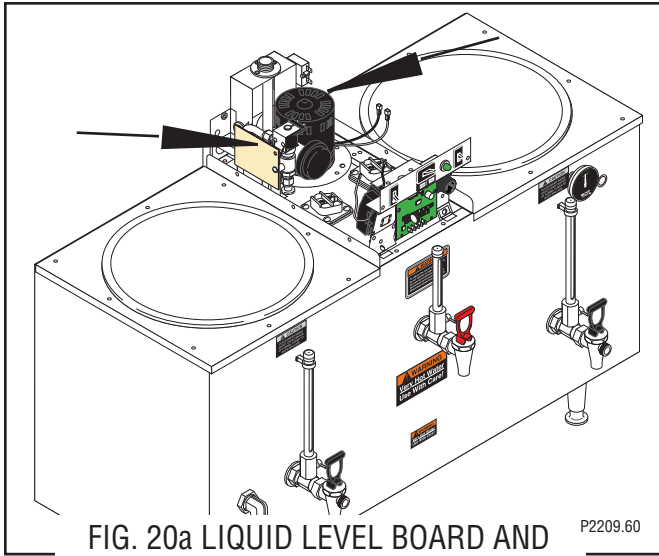

FIG. 20a LIQUID LEVEL BOARD AND LEVEL PROBE P2209.60

### Location: U3

The liquid level board is located on the left rear of the component bracket. The level probe is located on the right rear of the component bracket.

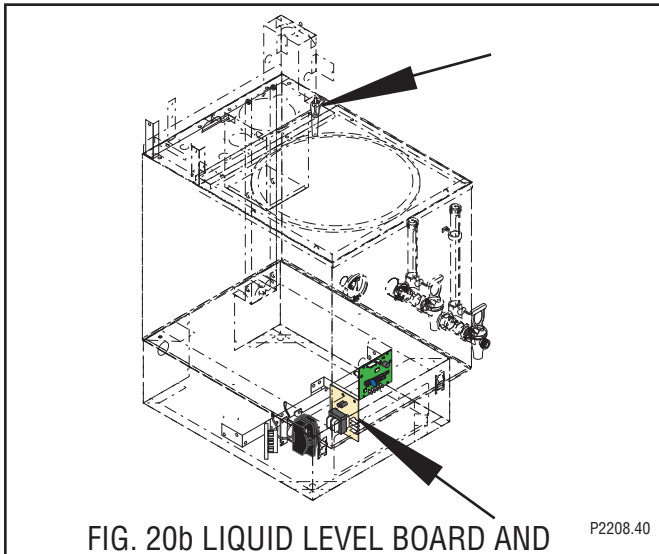

FIG. 20b LIQUID LEVEL BOARD AND LEVEL PROBE P2208.40

### Location: SRU

The liquid level board is located behind the lower front access panel, to the right of center on the component bracket. The level probe is located on the right front of the upper component bracket.

### Test Procedures:

1. Disconnect the brewer from the power source.
2. Disconnect the blue wire (T1) and the pink wire (T4).

3. Check the voltage across terminals (T2) and (T3) with the ON/OFF switch in the "ON" position. The indication must be:
  - a) 120 volts ac for 120/208 volt, 120/240 volt and 380 volt models.
  - b) 208 volts ac or 240 volts ac for two wire 208 volt or 240 volt models.
  - d) 230 volts ac for two wire 230 volt models.
  - e) 220 volts ac or 440 volts ac for four wire 280 volt or 440 volt machines.
4. Disconnect the brewer from the power source. If voltage is present as described, proceed to #5. If voltage is not present as described, refer to **Wiring Diagrams** and check the brewer wiring harness.

5. Reconnect the blue wire to T1 on the liquid level board.
6. Carefully connect a piece of insulated jumper wire to terminal 4. Keep the other end of this wire away from any metal surface of the brewer.
7. Touching the free end of the jumper to the brewer's frame simulates a "FULL" condition, preventing jumper from touching the brewer's frame simulates "NEED WATER" condition. Connect the brewer to the power source, simulate the conditions in the chart below while measuring the voltage between T1 and T3 On the liquid level board. Repeat these several times. There is an approximate five second delay for output to stabilize.

**NOTE: Marine versions typically use a LLB with an 11 second delay.**

<u>Model</u>	<u>Voltage - Jumper Not Touching Frame</u>	<u>Voltage - Jumper Touching Frame</u>
120/208V & 120/240V - 3 wire w/ground single phase	120V	0
230V - 2 wire w/ground single phase	230V	0
208V or 240V - 2 wire w/ground single phase	208V or 240V	0

(continued)

## LIQUID LEVEL BOARD AND LEVEL PROBE (cont.)

<u>Model</u>	<u>Voltage - Jumper Not Touching Frame</u>	<u>Voltage - Jumper Touching Frame</u>
280V or 440V - 4 wire w/ground 3 phase	220V or 254V	0 0
380V - 3 wire w/ground 3 phase w/ stepdown trans- former	120V	0

8. Disconnect the brewer from the power source and remove the jumper wire from terminal 4. If voltage is present as described, liquid level board is operating properly, proceed to #9. If voltage is not present as described, replace the liquid level board.
9. Reconnect the pink wire to terminal 4.
10. Remove the level probe and inspect for corrosion. Replace if necessary.
12. Place the probe so that neither end is in contact with any metal surface of the brewer.
13. Connect the brewer to the power source. Repeat steps 6-7, referring to chart.
14. Disconnect the brewer from the power source.

If voltage is present as described, reinstall the level probe, the liquid level board and level probe are operating properly.

If voltage is not present as described, check the pink wire on the level probe from liquid level board terminal 4.

### Removal and Replacement:

1. Remove all wires from the liquid level board.
2. Remove the #10-32 screw and flat washer securing the protective shield to the component bracket.
3. Remove the #10-32 screw and internal tooth lock washer securing the liquid level board to the component bracket.
4. Remove liquid level board and discard.
5. Install new liquid level board on component bracket and secure with a #10-32 screw and internal tooth lock washer.
6. Install protective shield and secure with #10-32 screw and flat washer.
7. Refer to Fig. 21a and reconnect the wires.

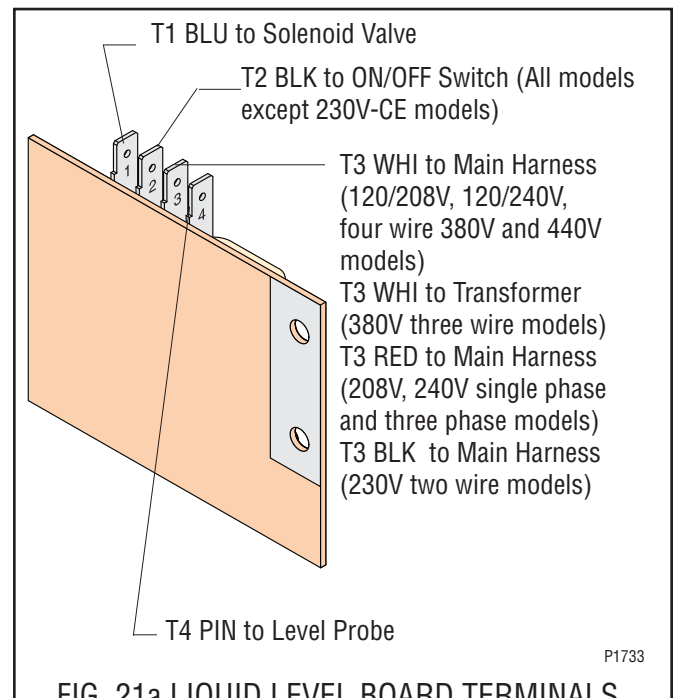

FIG. 21a LIQUID LEVEL BOARD TERMINALS

## DIGITAL TIMER (Late Models)

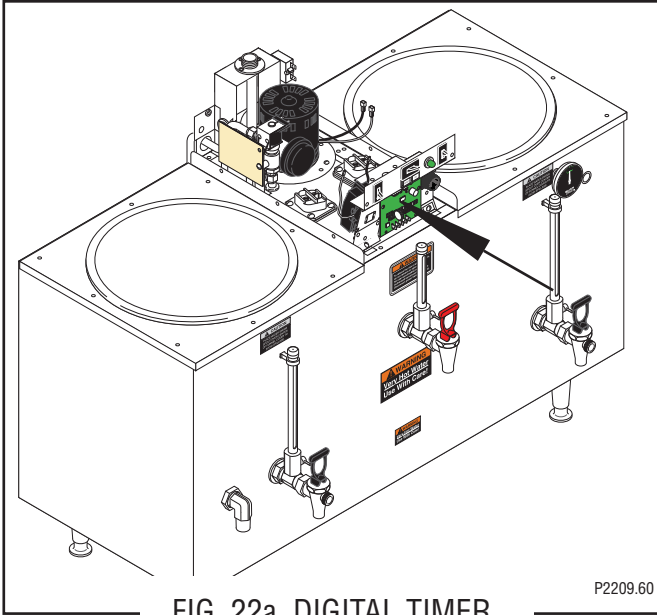

FIG. 22a DIGITAL TIMER

### Location: U3

The timer is located on the front center of the component bracket.

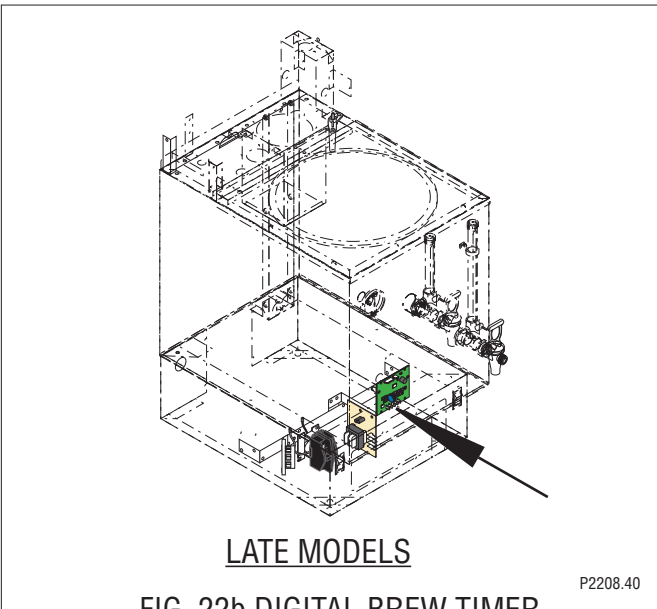

FIG. 22b DIGITAL BREW TIMER

### Location: SRU

The timer is located inside the front of the trunk on the top of the component bracket.

### Test Procedure.

**NOTE:** Do not remove or install wires while timer board is installed. Pressure applied to one side may cause damage to the board.

1. Disconnect the brewer from the power source.
2. With a voltmeter, check the voltage across terminals TL1 and TL2 when the "ON/OFF" switch is in the

"ON" position. Connect the brewer to the power source. The indication must be:

- a) 120 volts ac for three wire 120/208 volt, 120/240 volt and 380 volt models.
- b) 208 volts ac for two wire 208 volt models.
- c) 240 volts ac for two wire 240 volt models.
- d) 230 volts ac for two wire 230 volt CE models.
- e) 208 or 240 volts ac for four wire 440 volt models.

3. Disconnect the brewer from the power source.

If voltage is present as described, proceed to #4. If voltage is not present as described, refer to the **Wiring Diagrams** and check the brewer wiring harness.

4. With a voltmeter, check the voltage across terminals TL1 and TL4 when the "ON/OFF" switch is in the "ON" position. Connect the brewer to the power source. The indication must be 0 volts.

If voltage is as described, proceed to #5.

If voltage is not as described, disconnect the brewer from the power source and replace the timer.

5. With a voltmeter, check the voltage across terminals TL1 and TL4 when the "ON/OFF" switch is in the "ON" position. Connect the brewer to the power source and press the "START" switch. The indication must be as follows:
  - a) 120 volts ac for three wire 120/208 volt, 120/240 volt and 380 volt models.
  - b) 208 volts ac for two wire 208 volt models.
  - c) 240 volts ac for two wire 240 volt models.
  - d) 230 volts ac for two wire 230 volt CE models.
  - e) 208 or 240 volts ac for four wire 440 volt models.

If voltage is present as described, the brew timer is operating properly.

If voltage is not present as described, disconnect the brewer from the power source and replace the timer.

### Removal and Replacement:

1. Remove the two #8-32 screws securing circuit board to the mounting bracket.
2. Remove circuit board and spacers (as required).
3. Remove all wires from the timer.
4. Attach all wires to the replacement timer board prior to installation to the component mounting bracket. Refer to FIG. 23a when reconnecting the wires.

## DIGITAL TIMER (Late Models)

5. Install new circuit board with spacers (as required) to the component mounting bracket.
6. Adjust the timer as described below.

### Timer Setting:

**NOTE:** Prior to setting or modifying volumes, check that the brewer is connected to water supply, the tank

switch until you see three breaks in the water stream from the swing arm. Release the switch and press it again one or more times. (Failure to release the switch within two seconds after the third break in the water stream causes the volume setting to be aborted and previous volume setting will remain in memory.) Each time the switch is pressed, two seconds are added to the brew time period. Allow the brew cycle to finish in order to verify that the desired volume has been achieved.

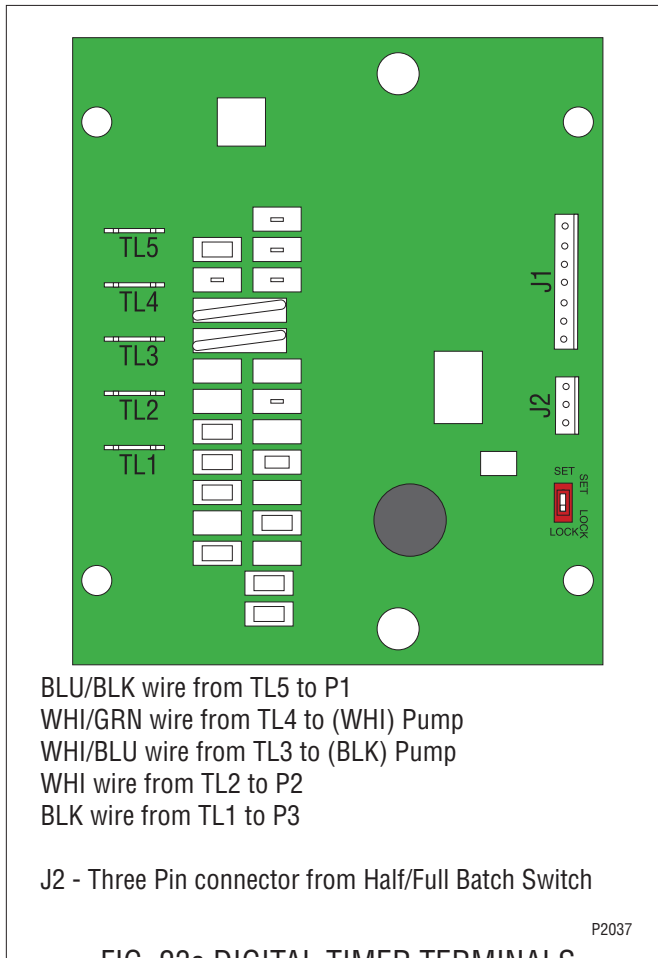

FIG. 23a DIGITAL TIMER TERMINALS

is properly filled, and funnel is in place.

**NOTE:** All volume settings must be done with the sprayhead installed.

1. **Modifying brew volumes.** To modify a brew volume, first check that the SET/LOCK switch is in the “SET” position on the circuit board.

**To increase a brew volume,** place the ON/OFF switch in the “ON” position, press and hold the START

**To decrease a brew volume,** place the ON/OFF switch in the “ON” position, press and release the START switch once for every two-second interval to be removed from the total brew time period; then immediately press and hold down the START switch until you see three breaks in the water stream from the swing arm. Release the switch. (Failure to release the switch within two seconds after the third break in the water stream causes the volume setting to be aborted and previous volume setting will remain in memory.) Allow the brew cycle to finish in order to verify that the desired volume has been achieved.

2. **Setting brew volumes.** To set a brew volume, first check that the SET/LOCK switch is in the “SET” position on the circuit board. Place the ON/OFF switch in the “ON” position, press and hold the START switch until you see three breaks in the water stream from the swing arm and then release the switch. (Failure to release the switch within two seconds after the third break in the water stream causes the volume setting to be aborted and previous volume setting will remain in memory.)

View the level of the liquid being dispensed. When the desired level is reached, turn the ON/OFF switch to “OFF”.

**NOTE:** The brewer remembers this volume and will continue to brew batches of this size until the volume setting procedure is repeated.

**NOTE:** When brewing coffee, volume will decrease due to absorption by the coffee grounds.

**NOTE:** Half-Batch and full batch settings must each be set separately.

## TIMER (Early Models)

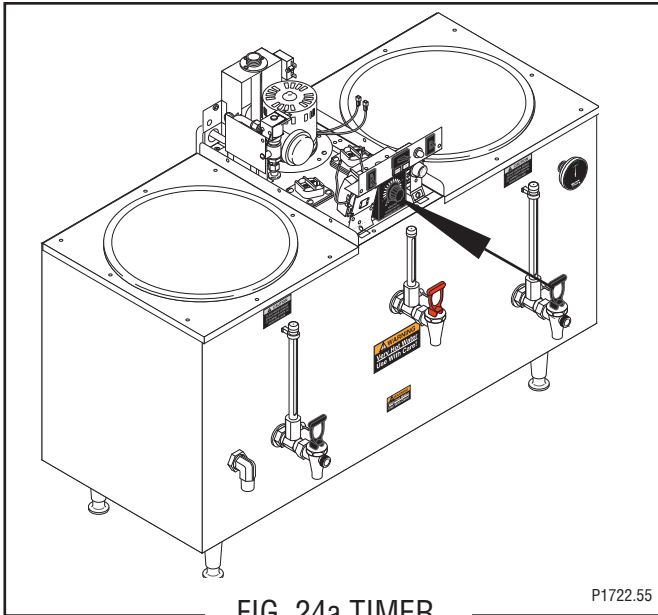

### Location: U3

The timer is located on the front center of the component bracket.

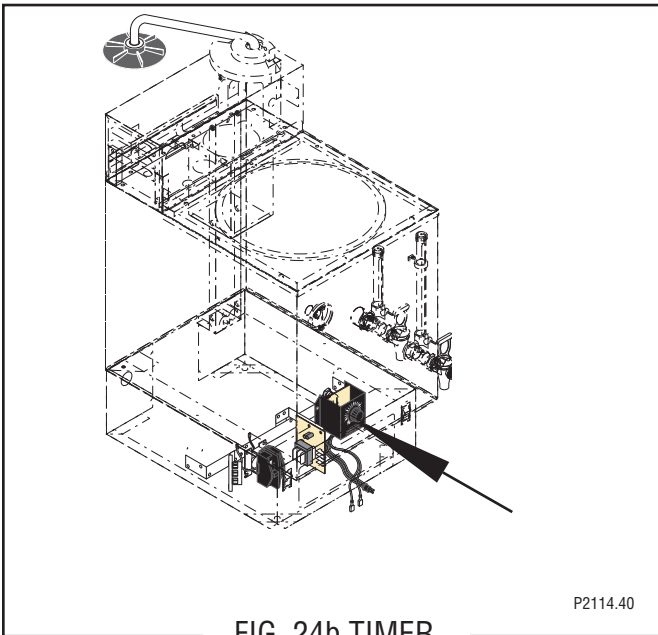

### Location: U3

The timer is located behind the front access panel on the right side of the component bracket.

### Test Procedures:

1. Disconnect the brewer from the power source.
2. Disconnect the polarized, three pin connector from the brewer main harness and rotate the brew timer

dial fully counterclockwise.

3. With a voltmeter, check the voltage across sockets P2 and P3 (white and black wire or red wire) of the female connector on the main wiring harness when the "ON/OFF" switch is in the "ON" (upper) position. Connect the brewer to the power source. The indication must be:
  - a) 120 volts ac for three wire 120/208 volt, 120/240 volt, 380 volt models and 208 or 240 volts ac for four wire 440 volt models.
  - b) 208 volts ac for two and three wire 208 volt models.
  - c) 240 volts ac for two and three wire 240 volt models.
  - d) 230 volts ac for two wire 230 volt CE models.
4. Disconnect the brewer from the power source.

If voltage is present as described, proceed to #5. If voltage is not present as described, refer to the **Wiring Diagrams** and check the brewer wiring harness.

5. With a voltmeter, check the voltage across the sockets P1 and P2 (blue and white wires) of the female connector on the main harness when the "ON/OFF" switch is in the "ON" (upper) position and the start switch pressed. Connect the brewer to the power source. The indication must be:
  - a) 120 volts ac for three wire 120/208 volt, 120/240 volt, 380 volt models and 208 or 240 volt ac for four wire 440 volt models.
  - b) 208 volts ac for two and three wire 208 volt models.
  - c) 240 volts ac for two and three wire 240 volt models.
  - d) 230 volts ac for two wire 230 volt CE models.
6. Disconnect the brewer from the power source.
7. Reconnect the three pin connector from the main wiring harness to the connector on the timer.

If voltage is present as described, proceed to #8. If voltage is not present as described, refer to the **Wiring Diagrams** and check the brewer wiring harness.

8. Disconnect the black and white wires to the pump.
9. With a voltmeter, check the voltage across the black and white wires when the "ON/OFF" switch is in the "ON" (upper) position and the start switch pressed to the start position and released. Connect the brewer to the power source. The indication

## TIMER (Early Models) (cont.)

must be:

- a) 120 volts ac for three wire 120/208 volt, 120/240 volt, 380 volt and 208 or 240 volt ac for four wire 440 volt models.
- b) 208 volts ac for two and three wire 208 volt models.
- c) 240 volts ac for two and three wire 240 volt models.
- d) 230 volts ac for two wire 230 volt CE models.

If voltage is present as described, the brew timer is operating properly. Reset the timer dial as required, to obtain the desired brew volume.

If voltage is not present as described, replace the timer.

### Removal and Replacement:

1. Separate all connectors between the brewer wiring harness and the timer.
2. Disconnect the timer leads from the pump leads.
3. Remove the two #8-32 screws securing the brew timer to the component bracket and remove timer.
4. Install new timer circuit board as described in **Digital Timer kit** instructions.

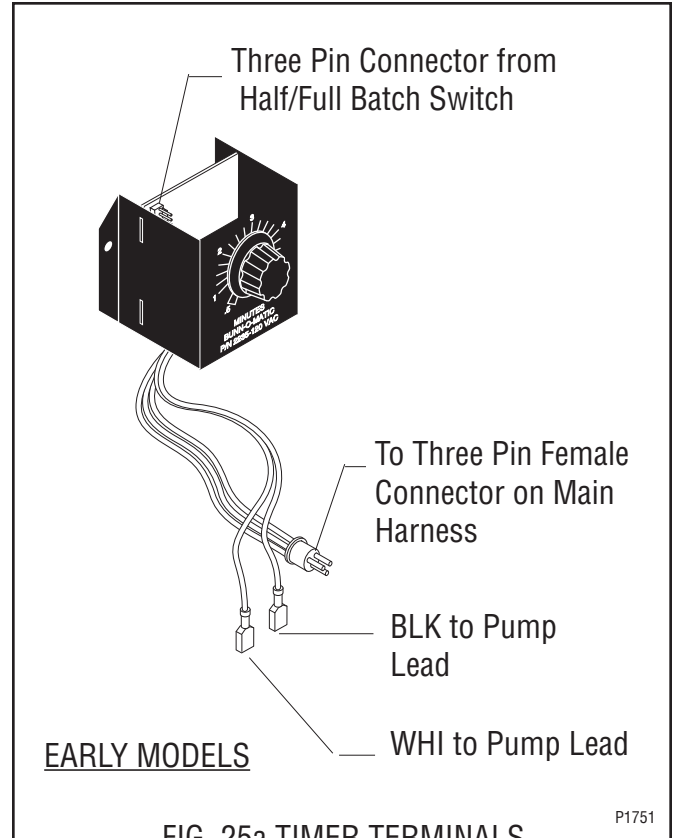

FIG. 25a TIMER TERMINALS

## PUMP ASSEMBLY

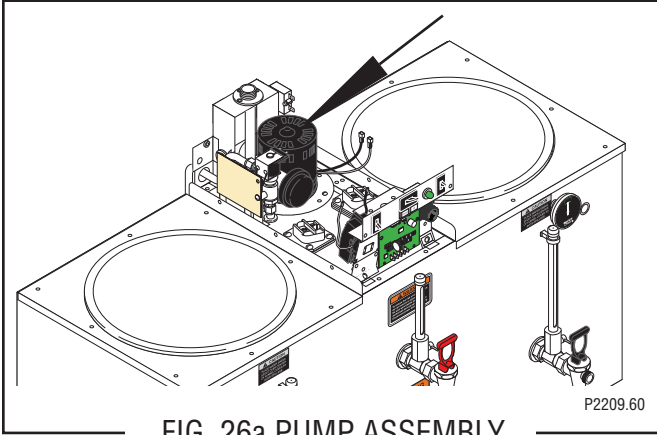

FIG. 26a PUMP ASSEMBLY

### Location: U3

The pump is located on the center rear of the component bracket.

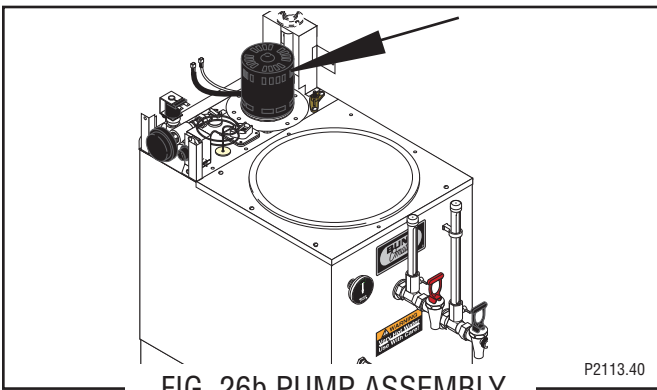

FIG. 26b PUMP ASSEMBLY

### Location: SRU

The pump is located on the center rear of the component bracket.

### Test Procedures:

1. Disconnect the brewer from the power source.
2. Disconnect the black wire from the black lead on the pump and the white wire from the black lead on the pump.
3. With a voltmeter, check the voltage across the black wire and the white wire. Connect the brewer to the power source. The indication must be:
  - a) 120 vac for three wire 120/208V, 120/240V and 380V models).
  - b) 208 vac for two or three wire 208V models.
  - c) 240 vac for two or three wire 240V models.
  - d) 230 vac for two wire 230V models.
  - e) 208 or 240 vac for four wire 440V models
4. Disconnect the brewer from the power source.

If voltage is present as described, reconnect the wires

to the pump. Install swing spout and position over the reservoir. Place the ON/OFF in the "ON" (upper) position and push the start switch and release. If pump does not run, replace the pump.

If voltage is not present as described, refer to the **Wiring Diagrams** and check the brewer wiring harness.

### Removal and Replacement (Refer to Fig. 17):

1. Disconnect the wires from the pump assembly.
2. Loosen the #8-32 screw (2) securing the clamp (3) on the fill tube (1) and slide the clamp (3) up the fill tube (1).
3. Disengage the tube (1) from the pump base (4).
4. Remove the four #8-32 screws (6) securing the pump assembly to the component bracket (7).
5. Remove pump assembly (4).
6. Remove pump gasket (5) and inspect, replace if necessary.
7. Position gasket (5) on component bracket (7).
8. Install new pump assembly on component bracket (7) and secure with four #8-32 screws (6).
9. Install fill tube (1) on pump assembly (4).
10. Slide clamp (3) down into position on the fill tube (1) and tighten screw (2).
11. Refer to Fig. 26c and reconnect the wires.

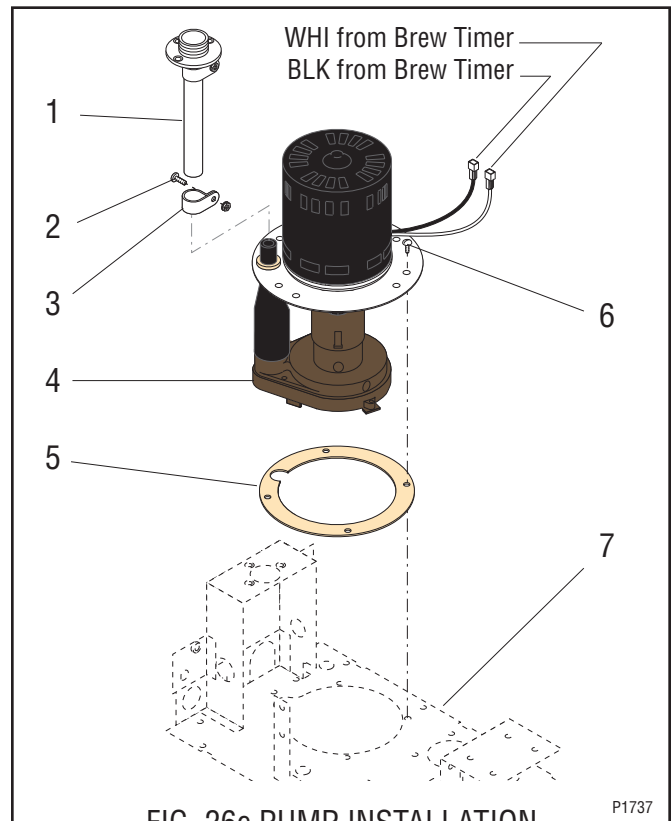

FIG. 26c PUMP INSTALLATION

## **U3 & SRU Motor/Pump Removal and Installation Instruction**

The pump/motor replacement kits include a new outlet tube with a flow restrictor installed within the tube. When you replace the original pump with the new replacement pump, the original outlet tube must be discarded and replaced with the new outlet tube with flow restrictor that is included with the new replacement pump.

1. Disconnect machine from power.
2. Remove the swing spout and top covers from the brewer.
3. Disconnect the pump electrical connection from the main wiring harness.
4. Disconnect the silicone tube from the pump and the swing spout base fitting. Discard tube.
5. Remove the four screws securing the motor/pump assembly to the component bracket. Remove the motor/pump assembly.
5. Install the new motor/pump onto the component bracket and secure with the four screws.
6. See Fig.1 - Install the new tube with flow restrictor to the pump and swing spout base fitting. Secure by using the two clamps and fastening hardware included in the kit.
7. Connect the motor/pump electrical wires to the main wiring harness.
8. Reinstall the machine top covers and swing spout.
9. Reconnect machine to power.
10. Adjust batch sizes/volumes by following the instruction outlined under "Adjusting Brew Volumes".

**Fig. 1**

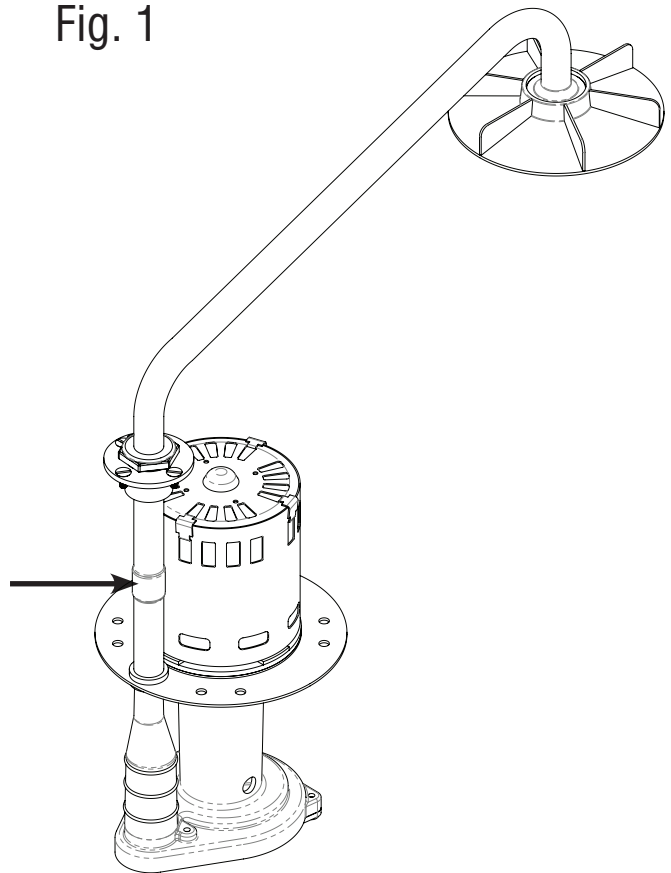

11. If the pump impeller is ever removed during servicing the pump, the impeller must be adjusted after reassembly.

12. See Fig. 4 - A template gauge is provided to adjust the impeller to the correct height.

Note: Cut out and apply template to poster board.

13. The pump bottom plate is secured by three screws. Remove the bottom plate in preparation of using the impeller adjustment template.

14. See Fig. 2 - Using the template, place the tab of the template on top of the impeller screw, the template should be resting or touching across the pedestal bottom rim.

15. See Fig. 3 - If a gap exists between the impeller screw or pedestal bottom rim, push down on the impeller and adjust the screw accordingly until template is touching all areas indicated or gap has been eliminated.

When finished adjusting the impeller screw, make sure the hex head of the impeller screw is correctly recessed in the impeller.

16. Reinstall the pump bottom plate and secure with screws.

17. Follow the Motor/Pump Installation and Adjusting Brew Volume instructions.

Fig. 2

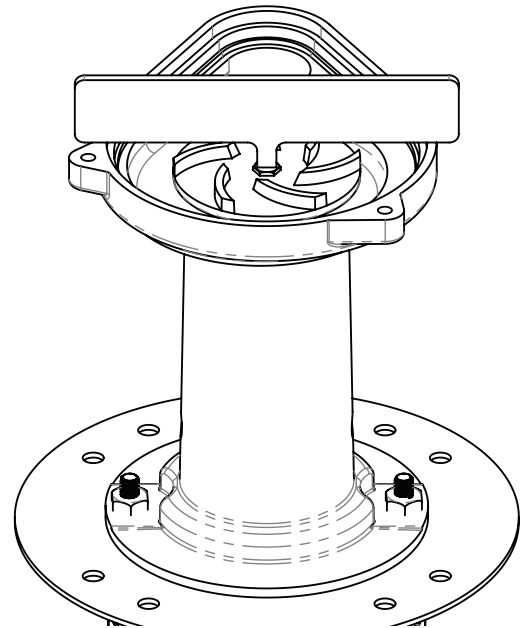

Fig. 3

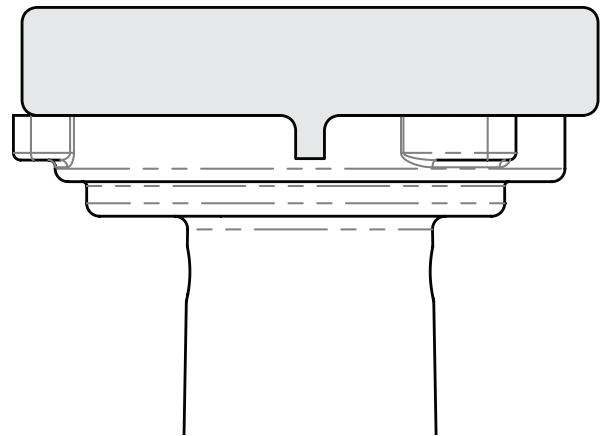
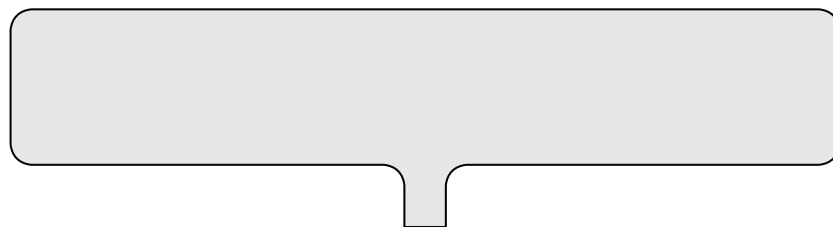

Fig. 4



**Additional Step Must Be Taken When Replacing An Early Style 50Hz. Motor/Pump Assembly.**

Fig. 5

1. Unscrew swing spout shield.
2. Remove the 33651.0000 flat washer and discard.
3. Remove only Qty-1, 01201.0000 gasket and discard.

**Note:** Qty-1, 01201.0000 gasket remains in the swing spout shield.

Fig. 5

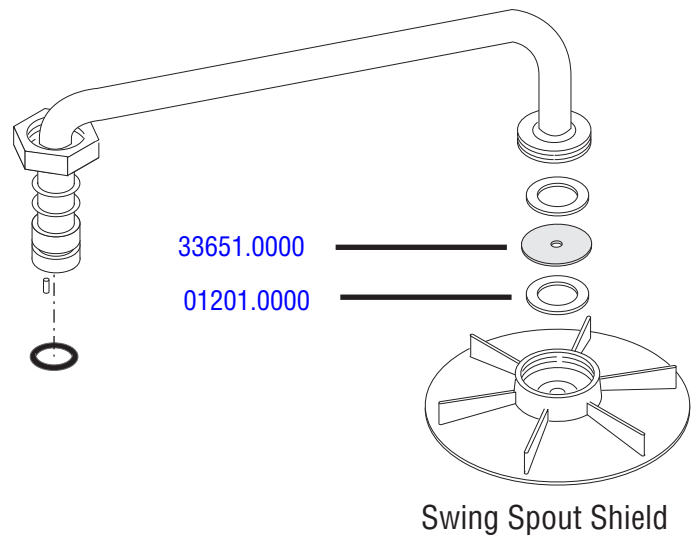

## ADJUSTING BREW VOLUMES

**CAUTION** - Disconnect the power source from the brewer prior to the removal of any panel for the replacement or adjustment of any component.

**NOTE:** Prior to setting or modifying batch sizes, check that the brewer is connected to water supply, the tank is properly filled, and a funnel support, funnel and funnel cover are in place.

1. **Modifying batch sizes.** To modify a batch volume, first check that the SET/LOCK switch is in the “SET” position on the circuit board.

**To increase a batch size.** Press and hold the START or BREW switch until you see three breaks in the water stream from the swing arm. Release the switch (Failure to release the switch within two seconds after the third break in the water stream causes the volume setting to be aborted and previous volume setting will remain in memory) and press it again one or more times. Each time the switch is pressed, two seconds are added to the brew time period. Allow the brew cycle to finish in order to verify that the desired volume has been achieved.

**To decrease a batch size.** Press and release the START or BREW switch once for every two-second interval to be removed from the total brew time period; then immediately press and hold down the START or BREW switch until you see three breaks in the water stream from the swing arm. Release the switch. (Failure to release the switch within two seconds after the third break in the water stream causes the volume setting to be aborted and previous volume setting will remain in memory). Allow the brew cycle to finish in order to verify that the desired volume has been achieved.

2. **Setting batch sizes.** To set a batch volume, first check that the SET/LOCK switch is in the “SET” position on the brew timer circuit board. Press and hold the START or BREW switch until you see three breaks in the water stream from the swing arm, and then release the switch. (Failure to release the switch within two seconds after the third break in the water stream causes the volume setting to be aborted and previous volume setting will remain in memory). View the level of the liquid being dispensed. When the desired level is reached, turn the ON/OFF switch to “OFF” (lower). The brewer remembers this volume and will continue to brew batches of this size until the volume setting procedure is repeated.

**NOTE:** When brewing coffee, batch volumes will decrease due to absorption by the coffee grounds.

**NOTE:** HALF-BATCH AND FULL BATCH SETTINGS MUST EACH BE SET SEPARATELY.

3. **Setting programming disable feature.** If it becomes necessary to prevent anyone from changing brew times once programmed, you can set the SET/LOCK switch to the “LOCK” position. This will prevent any programming to be done until switch is once again placed in the “SET” position.

## RELAY - BREW LOCKOUT OPTION

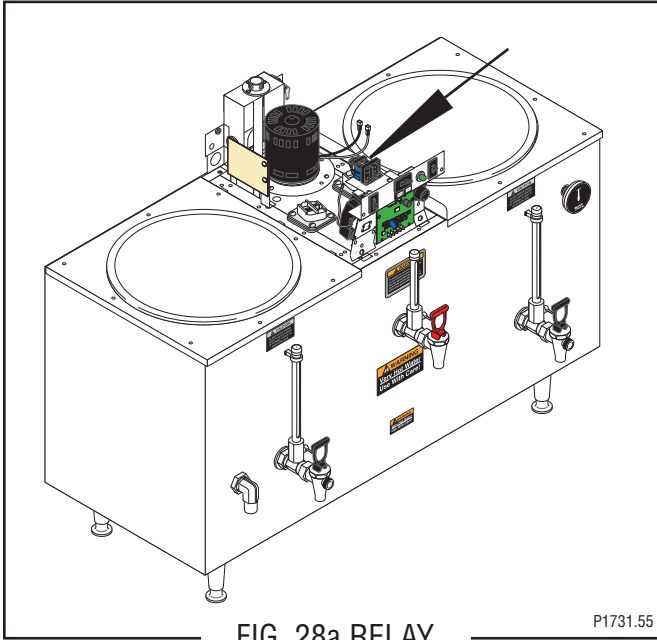

FIG. 28a RELAY

P1731.55

Location: U3

The relay is located on the front part of the component bracket, mounted on the top of the timer bracket.

### Test Procedures:

#### All Models Except 230V - CE Models

1. Disconnect the brewer from the power source.
2. Disconnect the wires from relay terminals A & B.  
Check for continuity between terminals A & B.

If continuity is present as described, reconnect the wires to terminals A & B and proceed to # 3.

If continuity is not present as described replace the relay.

3. Disconnect the wires from relay terminals 2 & 7.
4. Check for continuity across terminals 2 & 7.

If continuity is present as described, reconnect the wires to terminals 2 & 7 and proceed to # 5.

If continuity is not present as described, replace the relay.

5. Disconnect the wires from relay terminals 5 & 7.
6. Check for continuity across terminals 5 & 7 by manually closing relay contact. Continuity must not be present when contact is released.

If continuity is present as described, reconnect the

wires, the relay is operating properly.

If continuity is not present as described, replace the relay.

#### 230V - CE Models

1. Disconnect the brewer from the power source.
2. Disconnect the black wire from relay terminal A and the red wire from relay terminal B. Check the voltage across the black and red wire with a voltmeter. Connect the brewer to the power source. The indication must be 230 volts ac.

If voltage is present as described, proceed to #3.  
If voltage is not present as described, refer to the ***Wiring Diagrams*** and check the brewer wiring harness.

3. Disconnect the brewer from the power source.
4. Check for continuity between terminals A & B.

If continuity is present as described, reconnect the

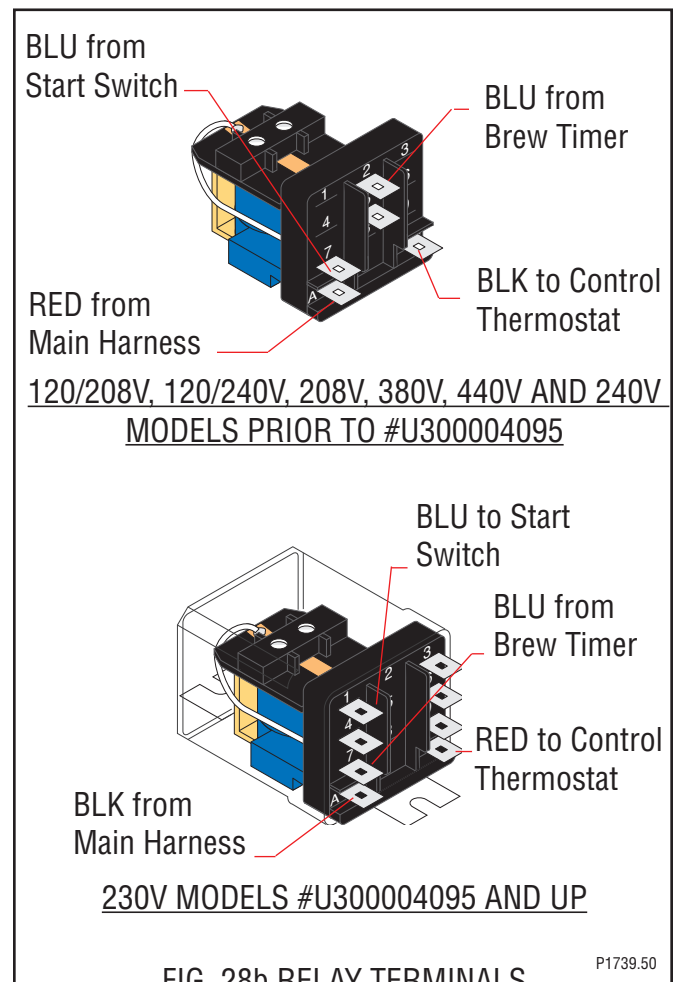

FIG. 28b RELAY TERMINALS

P1739.50

## RELAY - BREW LOCKOUT OPTION (cont.)

wires to terminals A & B and proceed to #5.

If continuity is not present as described, replace the relay.

5. With the thermostat in the "ON" position and the relay engaged disconnect the brewer from the power source.
6. Disconnect the blue wires from relay terminals 1 and 7. Check for continuity across terminals 1 and 7.

If continuity is present as described, proceed to #7

If continuity is not present as described, replace the relay.

7. Turn the thermostat to the "OFF" position, connect the brewer to the power source and turn the thermostat back to the "ON" position. Continuity should not be present across terminals 1 & 7.

If continuity is not present as described, the relay is operating properly.

If continuity is present as described, replace the relay.

### Removal and Replacement:

1. Disconnect the wires from the relay.
2. For 120/208V, 120/240V, 208V, 380V, 440V and 240V models prior to #U300004095 remove the #6-32 screw securing the relay to the relay mounting bracket. For 230V models #U300004095 and up, remove the two screws securing the relay to the relay mounting bracket.
3. Remove relay and discard.
4. For 120/208V, 120/240V, 208V, 380V, 440V and 240V models prior to #U300004095, install new relay on relay mounting bracket and secure with a #6-32 screw. For 230V models #U300004095 and up, install new relay on relay mounting bracket and secure with two #6-32 screws.
5. Refer to Fig. 28b and reconnect the wires.

## SOLENOID

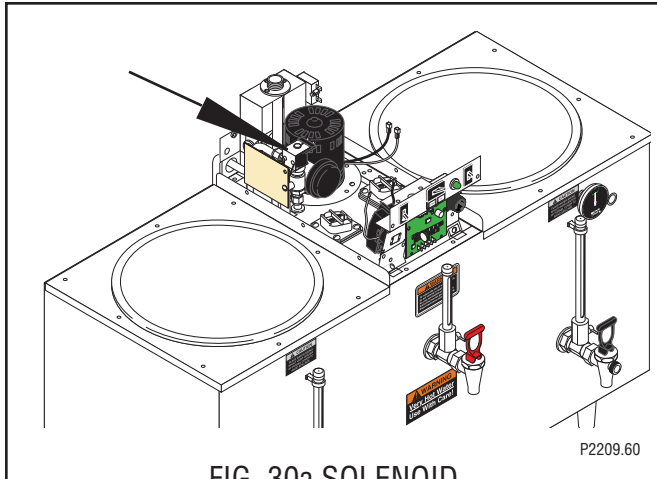

FIG. 30a SOLENOID

Location: U3

The solenoid is mounted on the upper left rear of the component bracket.

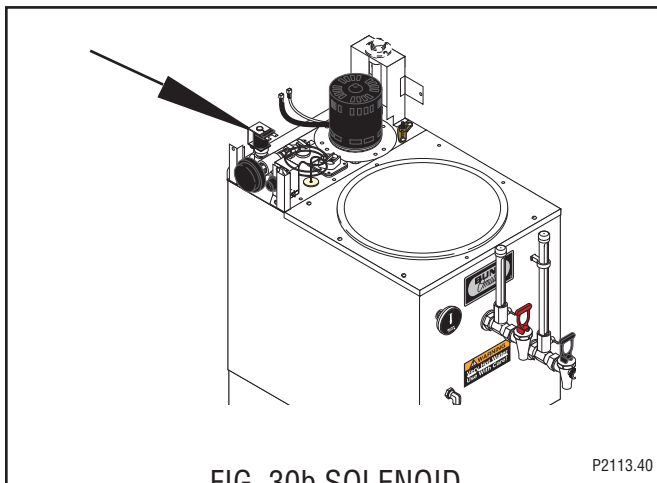

FIG. 30b SOLENOID

Location: SRU

The solenoid is mounted on the upper left rear of the component bracket.

### Test Procedures:

1. Disconnect the dispenser from the power source.
2. A) For 120/208 volt and 120/240 volt three wire, single phase models, 380 volt three wire, three phase models and 380 volt, 440 volt four wire, three phase models, disconnect the black wire from the liquid level board #2 and the white wire on the solenoid. With a voltmeter, check the voltage across the black and the white wire. Connect the brewer to the power source. The indication must be:
  - a) 120 volts ac for 380 volt three wire, three phase models and 208 or 240 volts ac for four wire three

phase 440 volt models.

b) 208 volts ac for three wire 120/208 volt models.

c) 240 volts ac for three wire 120/240 volt models.

B) For 208 volt, 240 volt two wire single phase and 208 volt, 240 volt three wire three phase models, disconnect the black wire from the liquid level board #2 and the red wire from the solenoid. With a voltmeter, check the voltage across the black and red wires. Connect the brewer to the power source. The indication must be:

a) 208 volts ac for 208 volt two wire single phase and 208 volt three wire three phase models.

b) 240 volts ac for 240 volt two wire single phase and 240 volt three wire three phase models.

C) For 230V - CE two wire single phase models, disconnect the red wire from the liquid level board #2 and the black wire from the solenoid. With a voltmeter, check the voltage across the red wire and the black wire. Connect the brewer to the power source. The indication must be 230 volts ac.

3. Disconnect the dispenser from the power source.

If voltage is present as described, proceed to #4.

If voltage is not present as described, refer to the brewer **Wiring Diagrams** and check the wiring harness.

4. Disconnect the blue wire and the white wire, the blue wire and the red wire or blue wire and black wire from the solenoid terminals.
5. Check for continuity across the solenoid valve coil terminals.

If continuity is present as described, reconnect the wires to the solenoid.

If continuity is not present as described, replace the solenoid valve.

6. Check the solenoid valve for coil action. Connect the dispenser to the power source. Listen carefully in the vicinity of the solenoid valve for a "clicking" sound as the coil magnet attracts.

If the sound is heard as described and water will not pass through the solenoid valve, there may be a blockage in the water line before the solenoid valve or, the solenoid valve may require inspection for wear, and removal of waterborne particles.

If the sound is not heard as described, replace the solenoid valve.

## SOLENOID (cont.)

### Removal and Replacement:

1. Remove the wires from the solenoid valve.
2. Turn off the water supply to the dispenser.
3. Disconnect the water inlet line from the connector

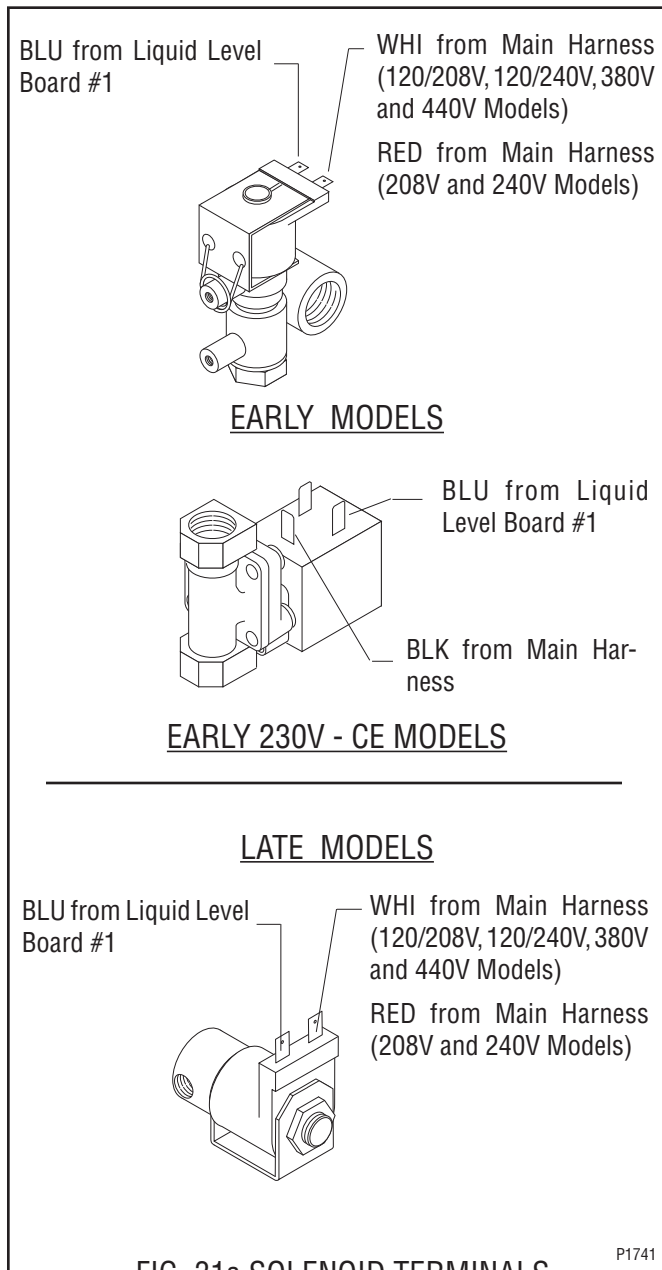

- on the solenoid valve.
4. Remove the #10-32 screw and the flat washer securing the liquid level board, shield and the solenoid to the component bracket.
5. Remove solenoid, connectors, air chamber and tank inlet tube as an assembly.
6. Remove the tank inlet tube grommet and discard.
7. Install new tank inlet tube grommet.
8. Install new solenoid assembly.
9. Install liquid level board, shield and secure solenoid assembly and shield to the component bracket with a #10-32 screw and flat washer..
10. Install water inlet tube to connector on the solenoid.
11. Turn on the water supply to the brewer.
12. Refer to Fig. 31a and reconnect the wires.

## TRANSFORMER (380V THREE WIRE MODELS ONLY)

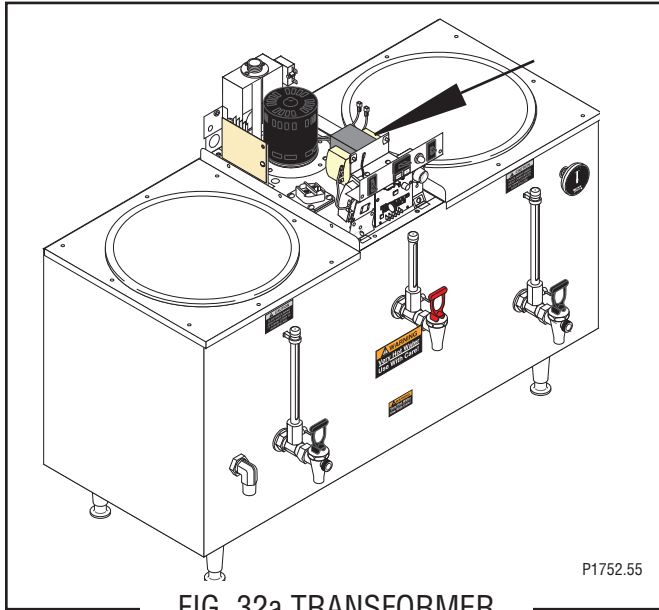

FIG. 32a TRANSFORMER

### Location:

\_\_\_ The transformer is located on the top rear of the timer mounting bracket.

### Test Procedures:

1. Disconnect the brewer from the power source.
2. Disconnect black wire and the red wire from the terminal block at the transformer.
3. With a voltmeter, check the voltage across the black wire and the red wire. Connect the brewer to the power source. The indication must be 380 volts ac.
4. Disconnect the brewer from the power source.

If voltage is present as described, proceed to #5.  
If voltage is not present as described, refer to wiring diagram and check the brewer wiring harness.

5. Reconnect the black wire and the red to the transformer.
6. Disconnect the black wire and the white wire from the transformer terminals.
7. With a voltmeter, check the voltage across the transformer terminals. Connect the brewer to the power source. The indication must be 120 volts ac.

If voltage is present as described, the transformer is operating properly

If voltage is not present as described, replace the transformer.

### Removal and Replacement:

1. Disconnect all the wires from the transformer.
2. Remove the two #8-32 screws securing the transformer to the transformer mounting bracket.
3. Remove the transformer and discard.
4. Position new transformer on transformer mounting bracket and secure with two #8-32 screws.
5. Refer to Fig. 32b and reconnect the wires.

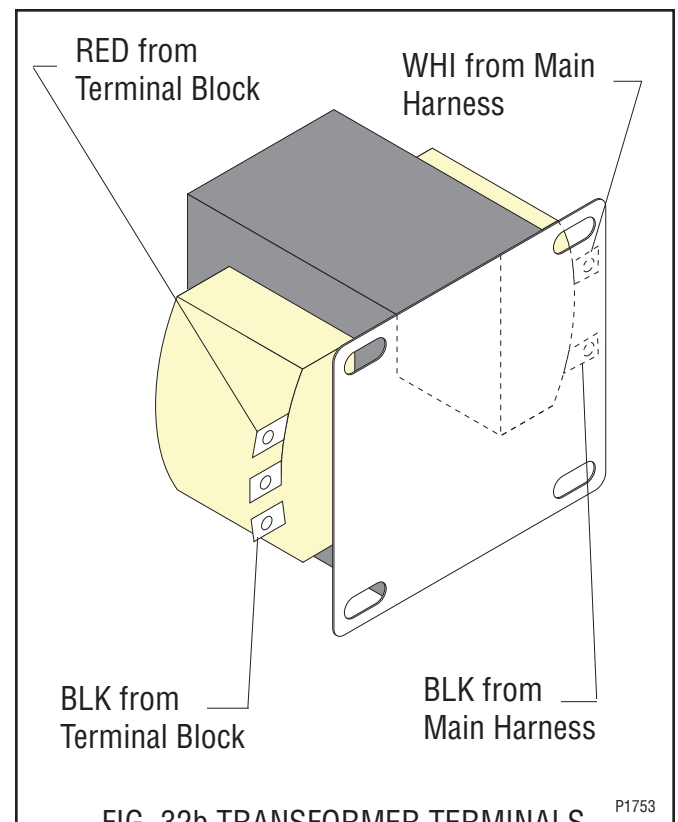

FIG. 32b TRANSFORMER TERMINALS

## MASTER ON/OFF SWITCH (Late Models)

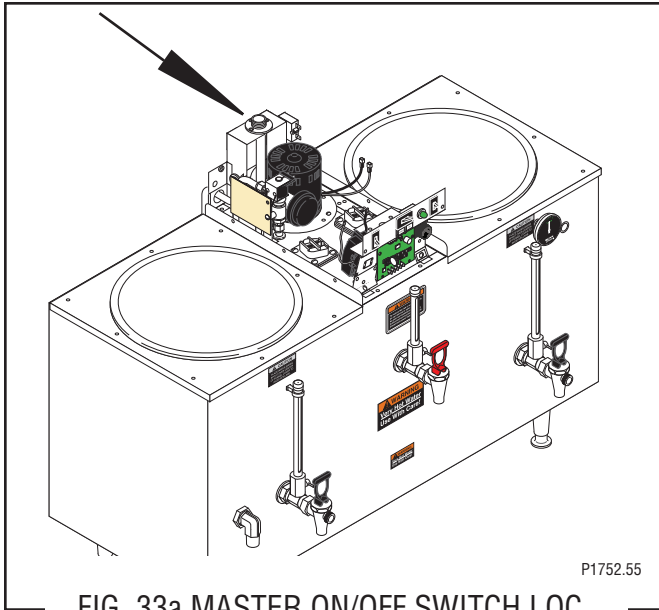

FIG. 33a MASTER ON/OFF SWITCH LOC.

### Location: U3

The Master ON/OFF switch is located in the top housing at the rear, FIG. 36.

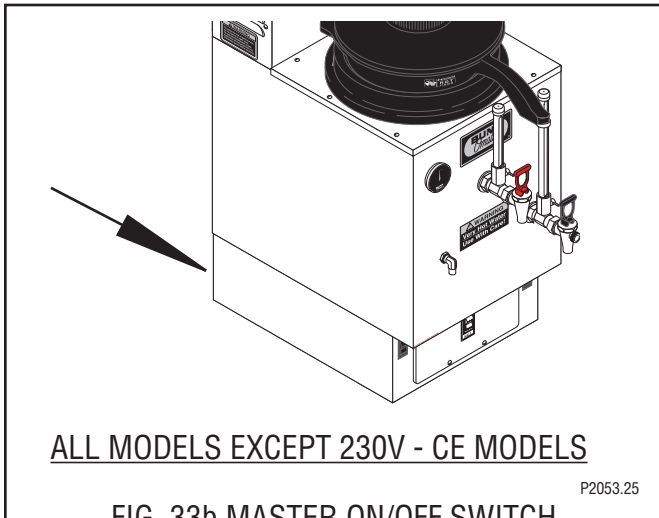

FIG. 33b MASTER ON/OFF SWITCH

### Location: SRU

The Master ON/OFF switch is located in the base, at the left rear, FIG. 31.

### Test Procedure:

1. Disconnect the brewer from the power source and remove the wires from all terminals of the Master ON/OFF switch.
2. Check for continuity across the two terminals on the switch at L1 BLK and BLK to Main Harness when it is held in the lower position, Fig. 32. Check for continuity across the two terminals on the switch at L2 RED and RED to Main Harness when it is held in the lower position. Continuity must not be present across these terminals in the upper position.

If continuity is present as described, reconnect the wires, the switch is operating properly.

If continuity is not present as described, replace the switch.

### Removal and Replacement:

1. Remove all wires from the switch terminals.
2. Remove the two screws from the outside of the base and gently push the switch through the opening.
3. Locate the new switch into the opening and secure with screws removed in step 2.
4. Refer to FIG. 33c when reconnecting the wires.

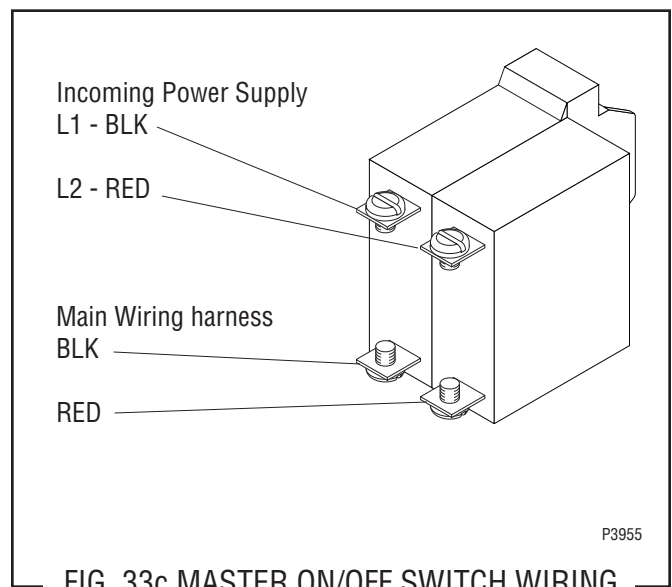

FIG. 33c MASTER ON/OFF SWITCH WIRING

## ON/OFF SWITCH

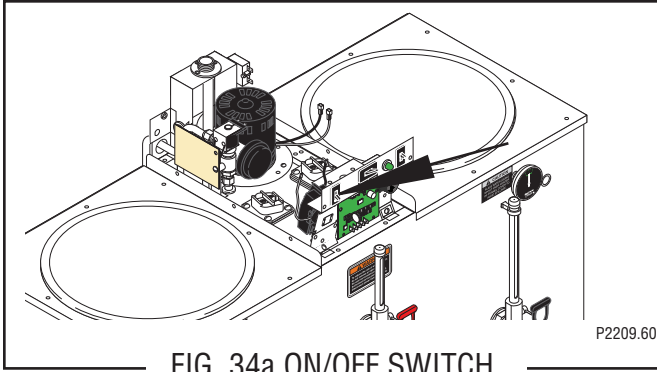

FIG. 34a ON/OFF SWITCH

### Location: U3

The ON/OFF switch is located on the left side of the switch mounting bracket. The switch mounting bracket is mounted on the front of the component bracket.

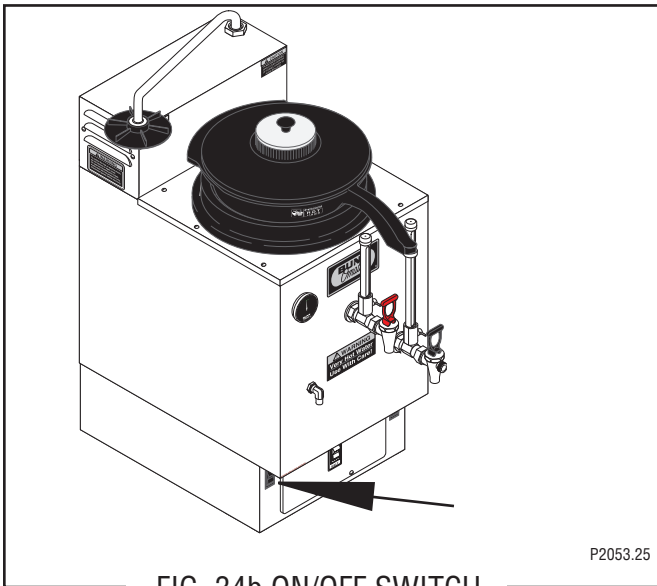

FIG. 34b ON/OFF SWITCH

### Location: SRU

The ON/OFF switch is located on the left side of the lower front panel.

### Test Procedures:

1. Disconnect the brewer from the power source.
2. a) 120/208V, 120/240V, 208V and 240V Models - Remove the black wire on the ON/OFF switch from the fuse holder or circuit breaker and the red wire on the power indicator light.
- b) 380V and 440V Models - Remove the black wire on the ON/OFF switch from the fuse holder or circuit breaker and the white wire from the power indicator light.
- c) 230V - CE Models - Remove the red wire on the ON/OFF switch from the fuse holder and the black

wire on the power indicator light.

3. Connect the brewer to the power source. With a voltmeter, check the voltage across the removed wires. The indication must be:
  - a) 120 volts ac for 120/208 volt, 120/240 volt and 380 volt models.
  - b) 208 volts ac for two or three wire 208 volt models.
  - c) 240 volts ac for two wire 240 volt models prior to #U300004095 and three wire 240 volt models.
  - d) 230 volts ac for two wire 230 volt models #U300004095 and up).
  - e) 208 or 240 volts ac for four wire 440 volt models.
4. Disconnect the brewer from the power source.

If voltage is present as described, reconnect the wires and proceed to #5

If voltage is not present as described, refer to the **Wiring Diagrams** and check the brewer wiring harness.

5. Disconnect the wires on the ON/OFF switch.
6. a) 120/208V, 120/240V, 208V, 240V, 380V and 440V Models - Check for continuity across the terminals on the rear of the switch with the switch in the "ON" (upper) position. Continuity must not be present when the switch is in the "OFF" (lower) position.
- b) 230V - CE Models - Check for continuity across the center terminal (2) and the lower terminal (1) when the switch is in the "ON" (upper) position. Continuity must not be present when the switch is in "OFF" (lower) position.

If continuity is present as described, the switch is operating properly.

If continuity is not present as described, replace the switch.

### Removal and Replacement:

1. Remove the wires from the switch terminals.
2. Compress the clips on the back side of the switch mounting bracket and gently push the through the opening.
3. Push the new switch into the opening and spread the clips to hold switch in the mounting bracket.

**NOTE:** ON 230V - CE models terminal (3) must be on the top.

4. Refer to Fig. 35a and reconnect the wires.

**ON/OFF SWITCH (cont.)**

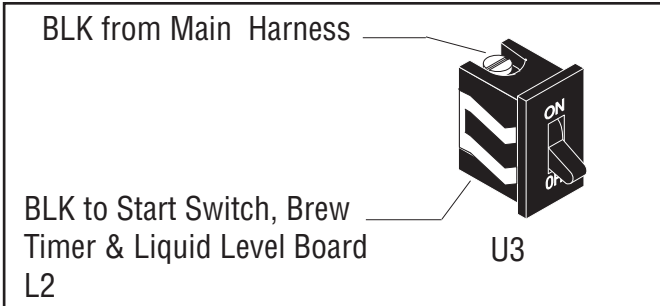

120/208V, 120/240V, 208V, 240V, 380V AND 440V MODELS

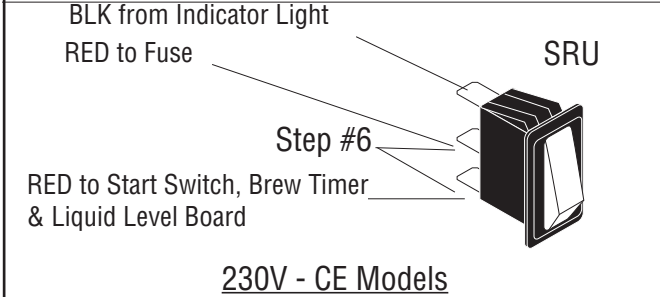
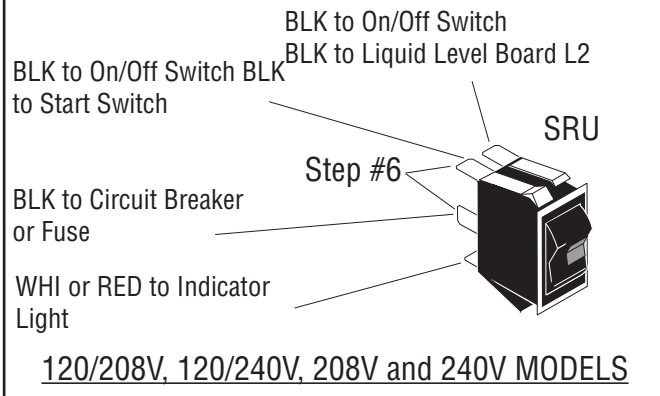
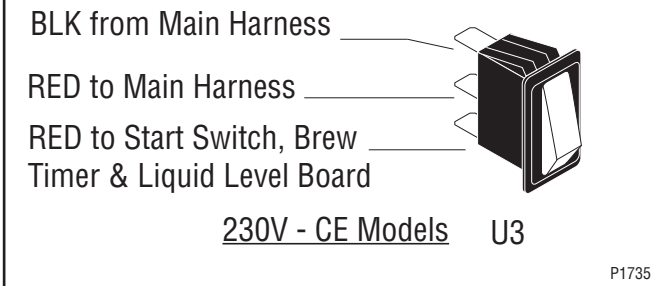
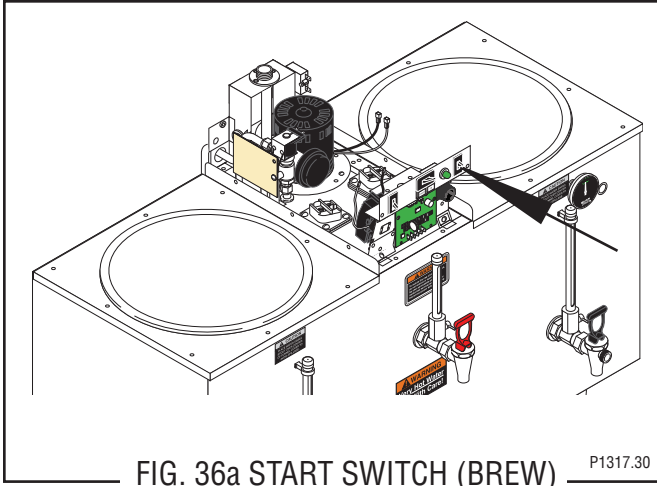

FIG. 35a ON/OFF SWITCH TERMINALS P2120.50

## START SWITCH (BREW) U3



### Location: U3

The brew start switch is located on the upper right side of the brewer component housing.

### Test Procedures:

1. Disconnect the brewer from the power source.
2. Remove the wires from the start switch terminals.
3. Check for continuity across the switch terminals when the switch is held in the lower position. Continuity must not be present when the switch is in the upper position.

If continuity is present as described, reconnect the wires the switch is operating properly.

If continuity is not present as described, replace the switch.

### Removal and Replacement:

1. Remove the wires from the switch terminals.
2. Compress the clips on the back side of the switch mounting bracket and gently push the through the opening.
3. Push the new switch into the opening and spread the clips to hold switch in the mounting bracket.
4. Refer to Fig. 36b and reconnect the wires.

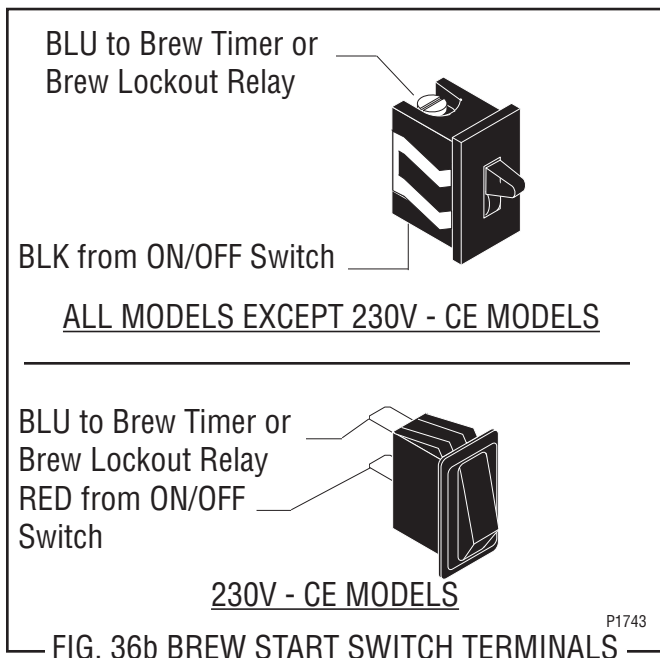

## START SWITCH (BREW) SRU

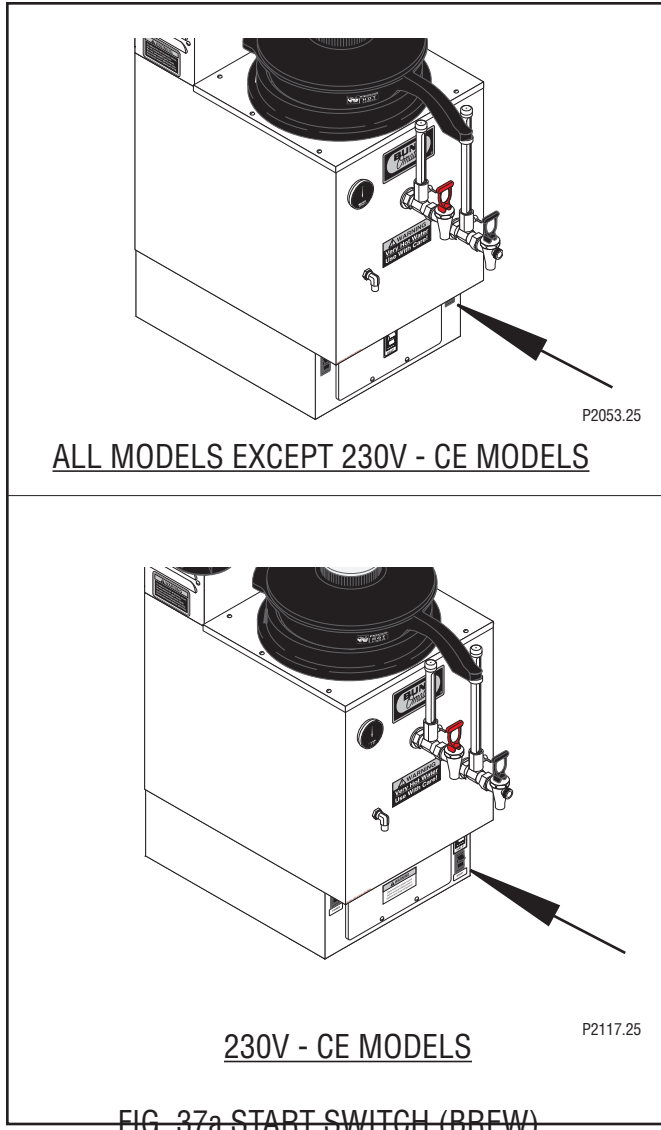

### Location: SRU

The brew start switch is located on the lower right side of the front access panel at the base of the urn on all models except 230 volt CE. On 230 volt CE models, the start switch is located on the lower right of the front access panel, beneath the selector switch.

### Test Procedures:

1. Disconnect the brewer from the power source.
2. Remove the wires from the start switch terminals.
3. Check for continuity across the switch terminals when the switch is held in the lower position. Continuity must not be present when the switch is in the upper position.

If continuity is present as described, reconnect the wires the switch is operating properly.

If continuity is not present as described, replace the switch.

### Removal and Replacement:

1. Remove the wires from the switch terminals.
2. Compress the clips on the back side of the switch mounting panel and gently push them through the opening.
3. Push the new switch into the opening and spread the clips to hold switch in the mounting panel.
4. Refer to Fig. 37b and reconnect the wires.

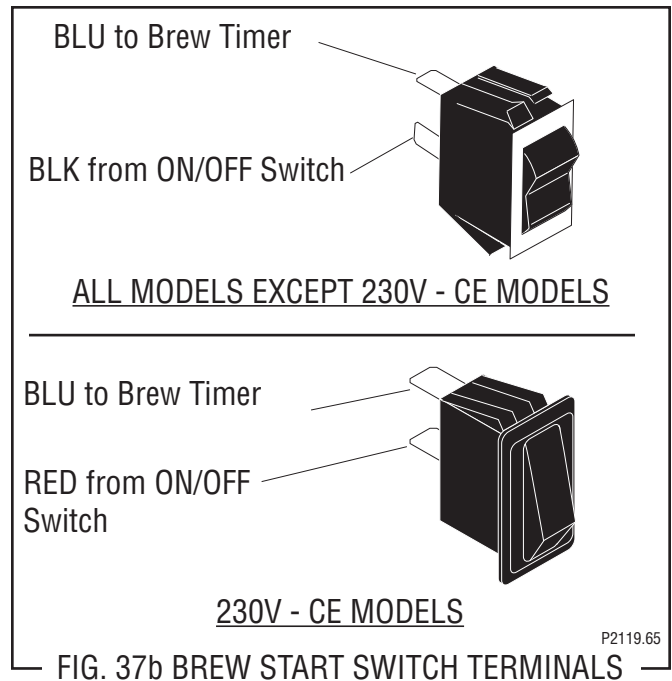

## SELECTOR SWITCH (HALF BATCH OPTION) U3

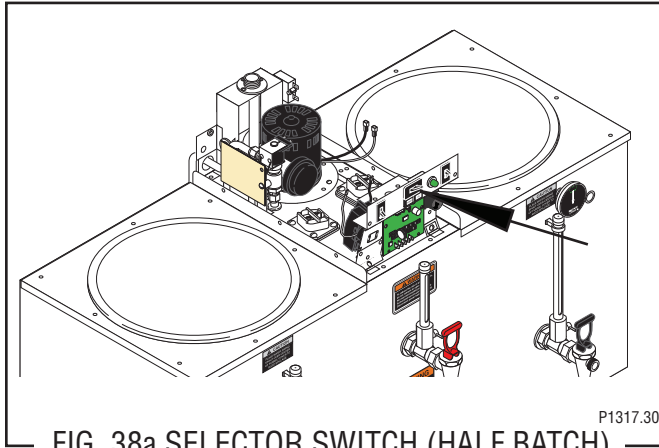

FIG. 38a SELECTOR SWITCH (HALF BATCH)

### Location: U3

The selector switch is located in the upper center of the switch mounting panel.

### Test Procedures:

1. Disconnect the brewer from the power source.
2. Disconnect the wires from the switch terminals.
3. Check for continuity across the switch terminals with the switch in the "CLOSED" (left - half) position. Continuity must not present when the switch is in the "OPEN" (right - full) position.

If continuity is present as described, the switch is operating properly.

If continuity is not present as described, replace the switch.

### Removal and Replacement:

1. Remove the wires from the switch terminals.
2. Compress the clips on the back side of the switch mounting bracket and gently push the through the opening.
3. Push the new switch into the opening and spread the clips to hold switch in the mounting bracket.
4. Refer to Fig. 38b and reconnect the wires.

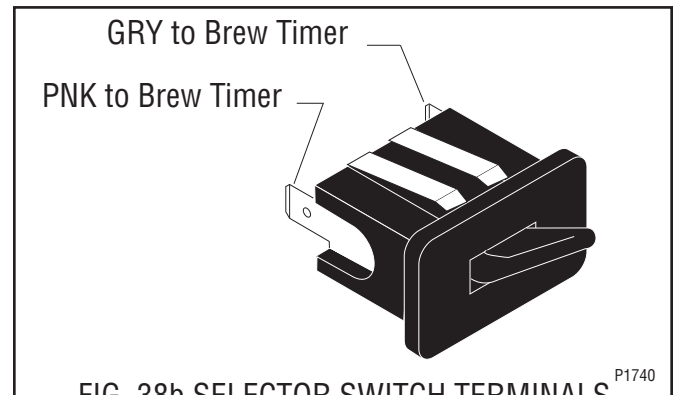
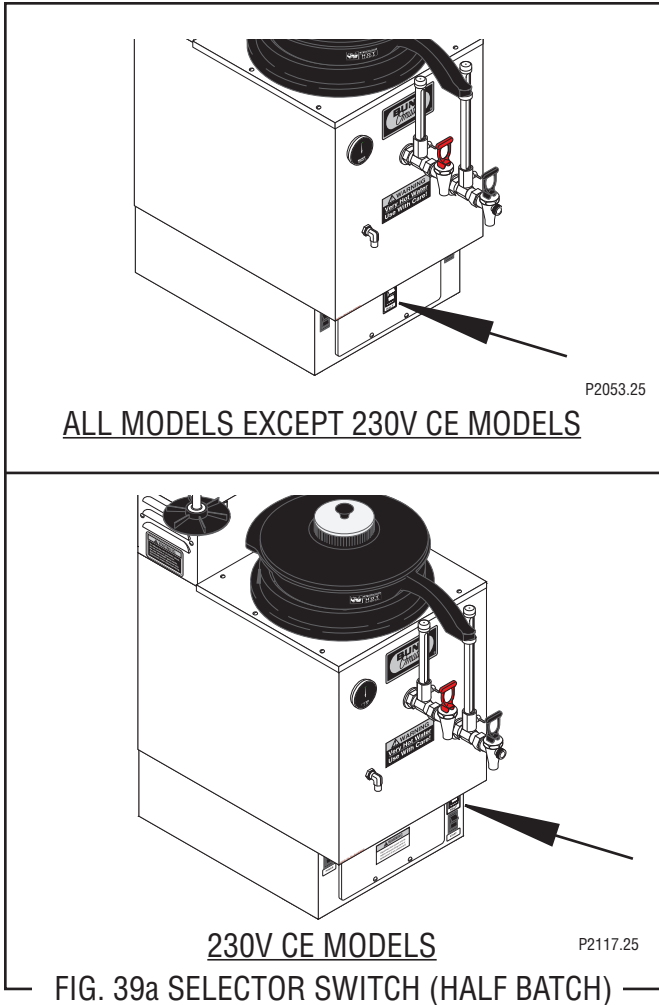

FIG. 38b SELECTOR SWITCH TERMINALS

## SELECTOR SWITCH (HALF BATCH OPTION) SRU



### Location: SRU

The selector switch is located in the center of the front access panel at the base of the urn on all models except the 230V CE Models. The selector switch is located to the right of the front panel, above the start switch on the 230V CE Models.

### Test Procedures:

1. Disconnect the brewer from the power source.
2. Disconnect the wires from the switch terminals.
3. Check for continuity across the switch terminals with the switch in the "CLOSED" (bottom - half) position. Continuity must not be present when the switch is in the "OPEN" (top - full) position.

If continuity is present as described, the switch is operating properly.

If continuity is not present as described, replace the switch.

### Removal and Replacement:

1. Remove the wires from the switch terminals.
2. Compress the clips on the back side of the switch mounting panel and gently push them through the opening.
3. Push the new switch into the opening and spread the clips to hold switch in the mounting panel.
4. Refer to Fig. 39b and reconnect the wires.

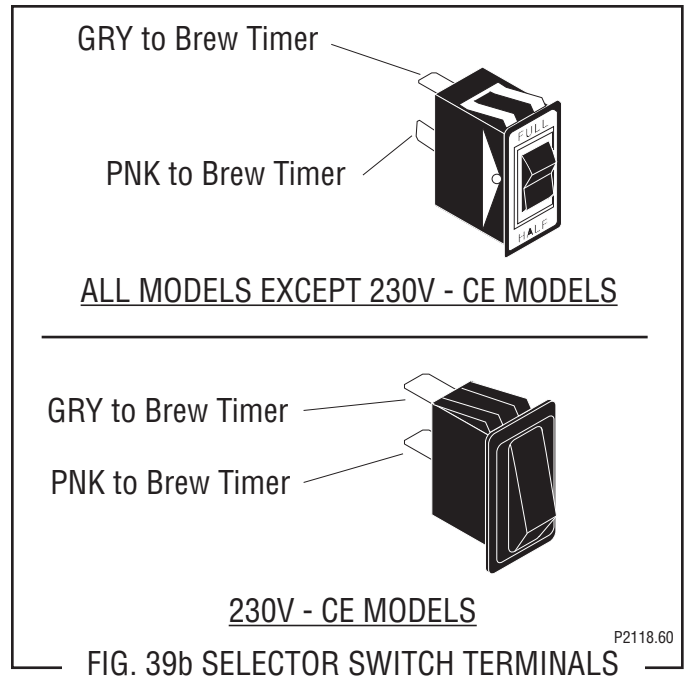

# SCHEMATIC WIRING DIAGRAM SRU

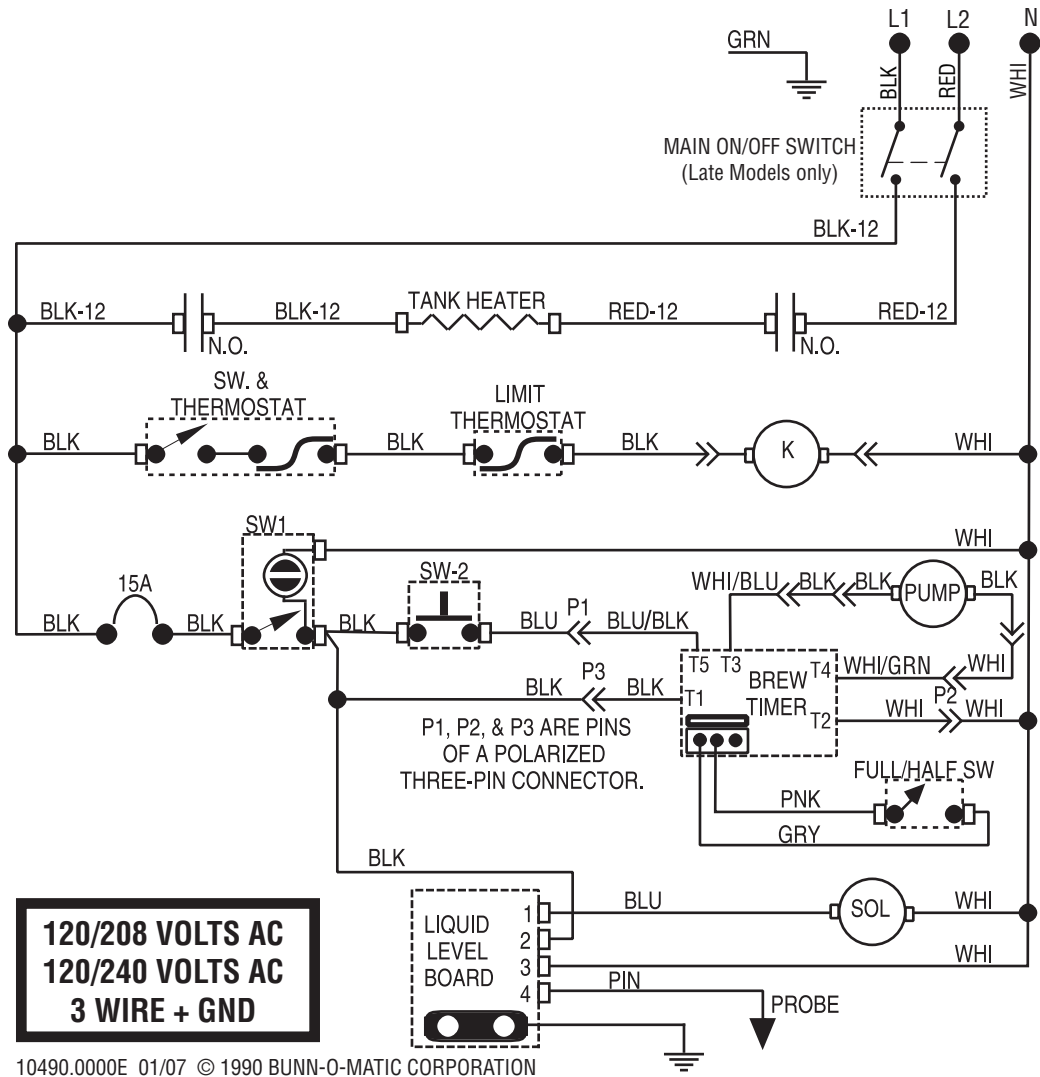

# SCHEMATIC WIRING DIAGRAM SRUA

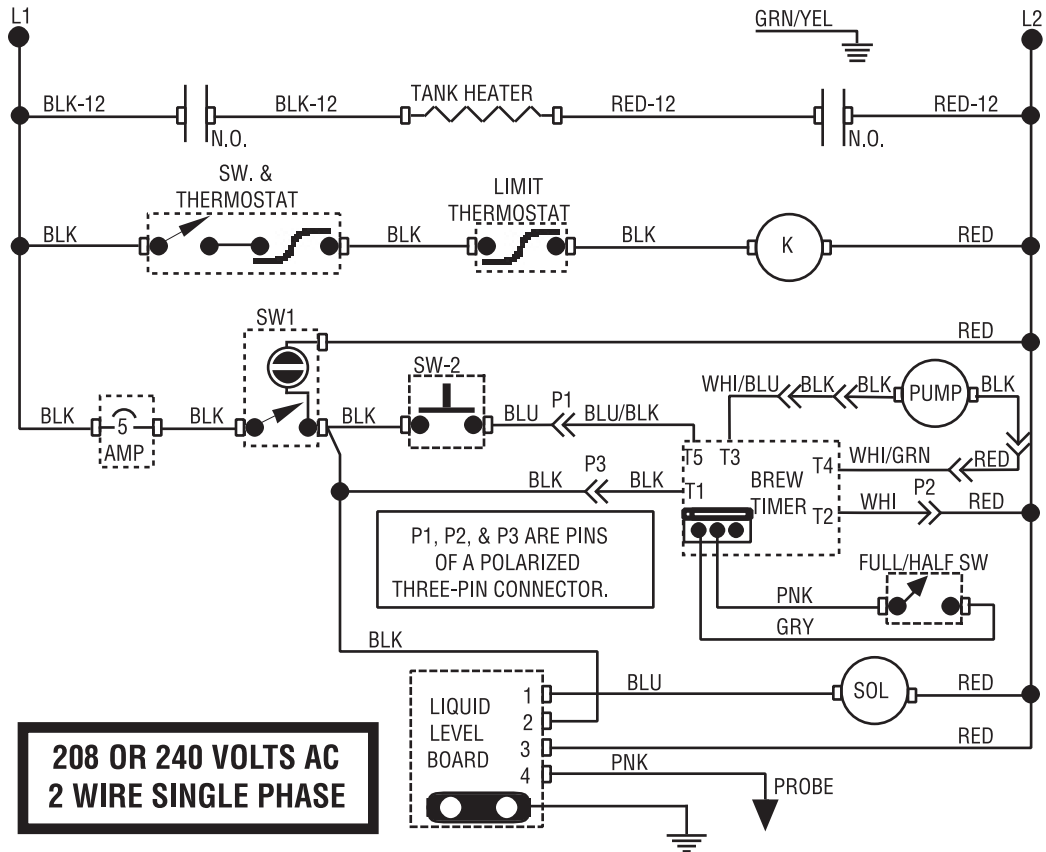

10491.0000E 8/00 © 1990 BUNN-O-MATIC CORPORATION

# SCHEMATIC WIRING DIAGRAM SRUA - CE

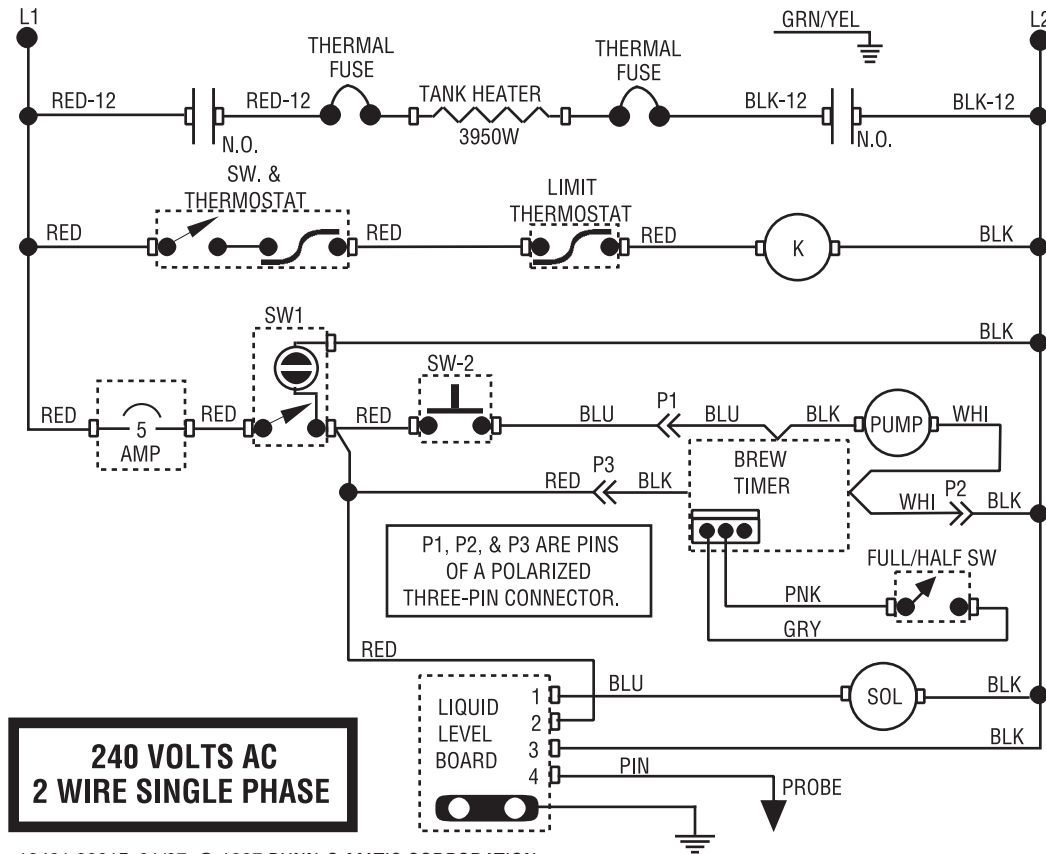

**240 VOLTS AC  
2 WIRE SINGLE PHASE**

10491.0001F 01/07 © 1997 BUNN-O-MATIC CORPORATION

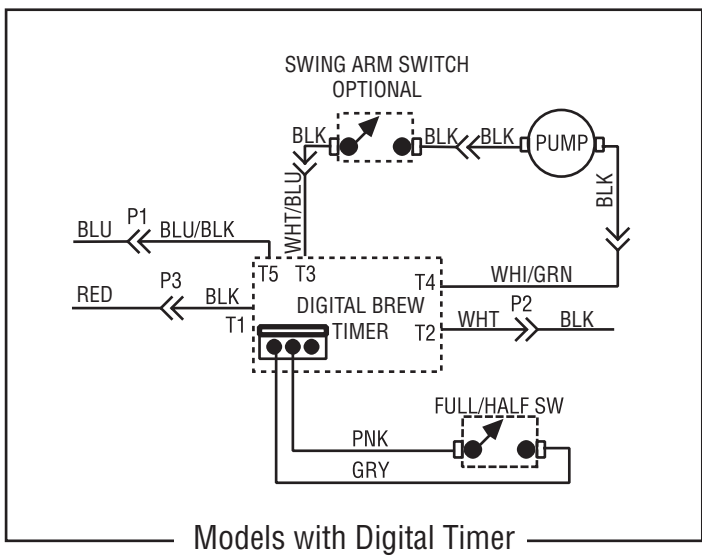

Models with Digital Timer

# SCHEMATIC WIRING DIAGRAM SRUA - CE

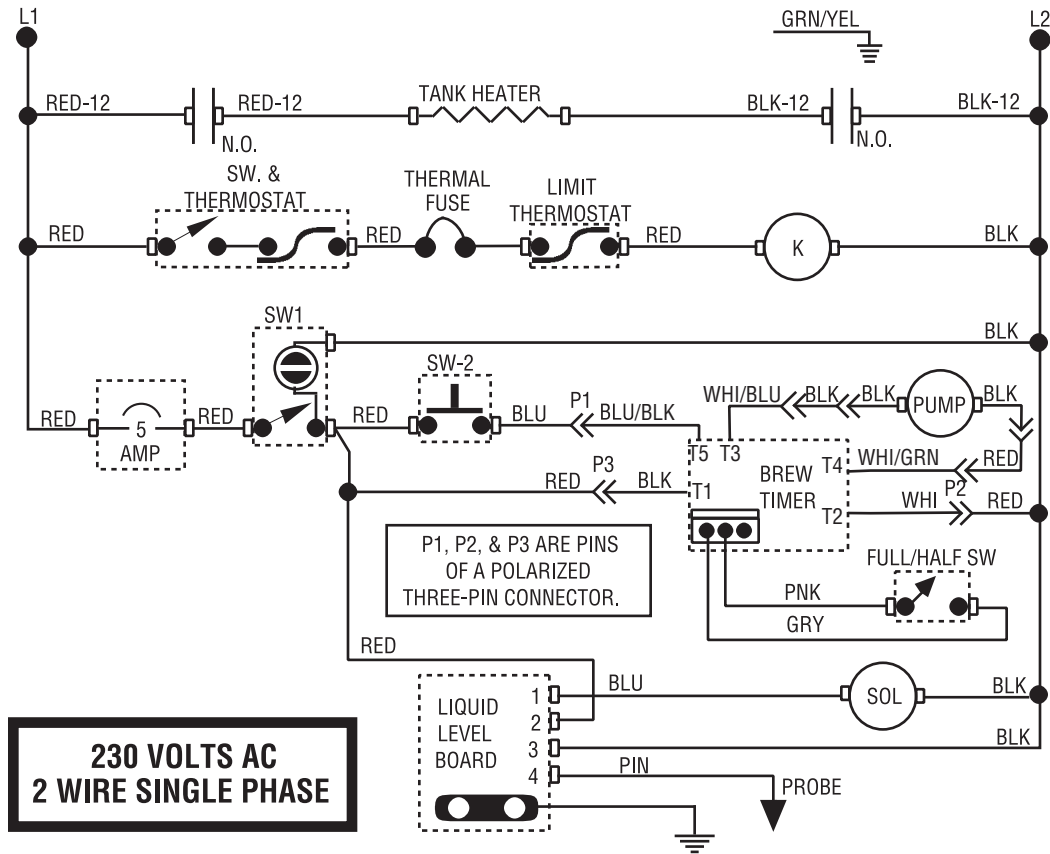

**230 VOLTS AC  
2 WIRE SINGLE PHASE**

10491.0002G 8/00 © 1997 BUNN-O-MATIC CORPORATION

# SCHEMATIC WIRING DIAGRAM SRUA - CE

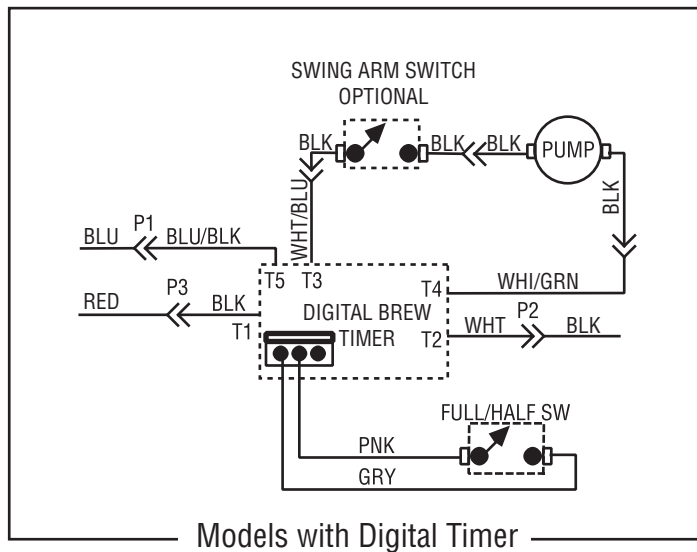
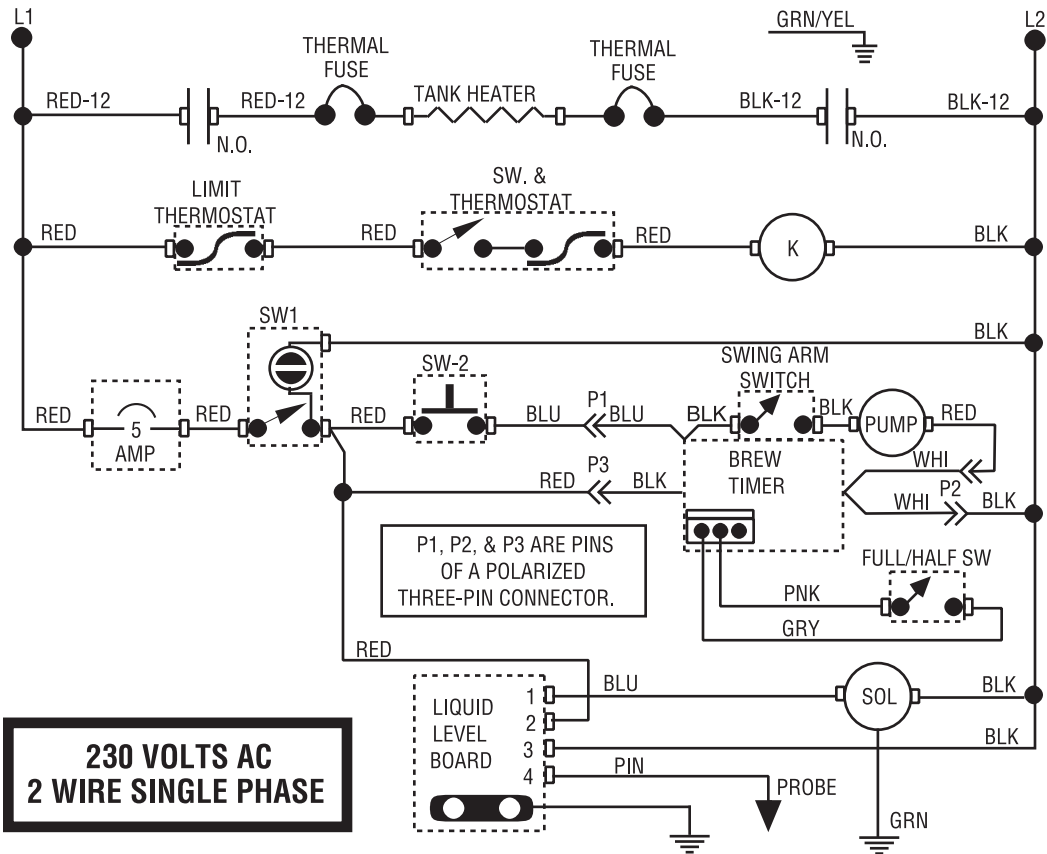

# SCHEMATIC WIRING DIAGRAM SRUA - CE

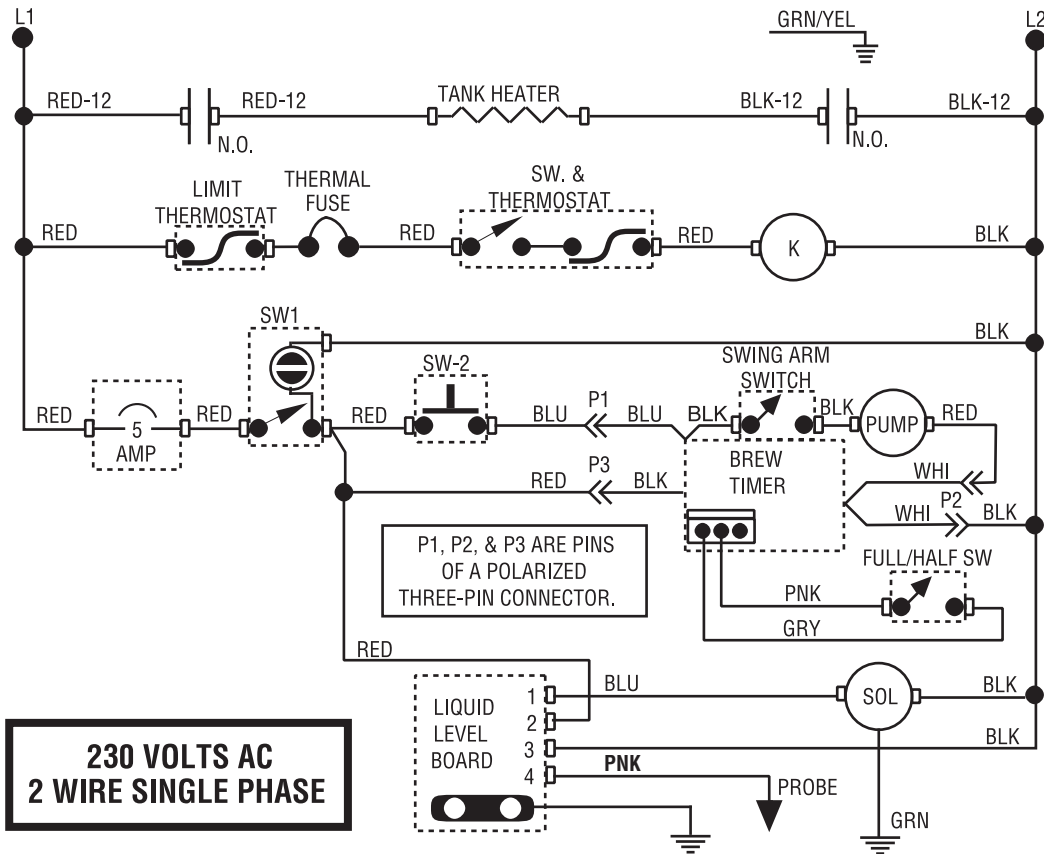

**230 VOLTS AC  
2 WIRE SINGLE PHASE**

10491.0004C 01/07 © 2002 BUNN-O-MATIC CORPORATION

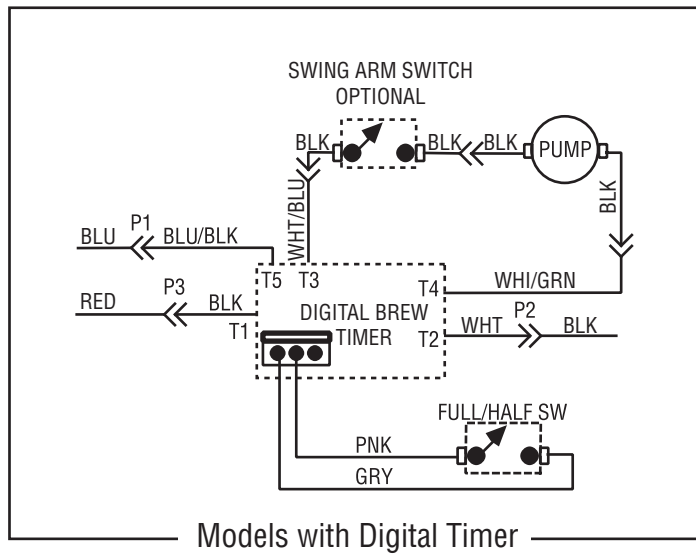

# SCHEMATIC WIRING DIAGRAM SRUA - CE

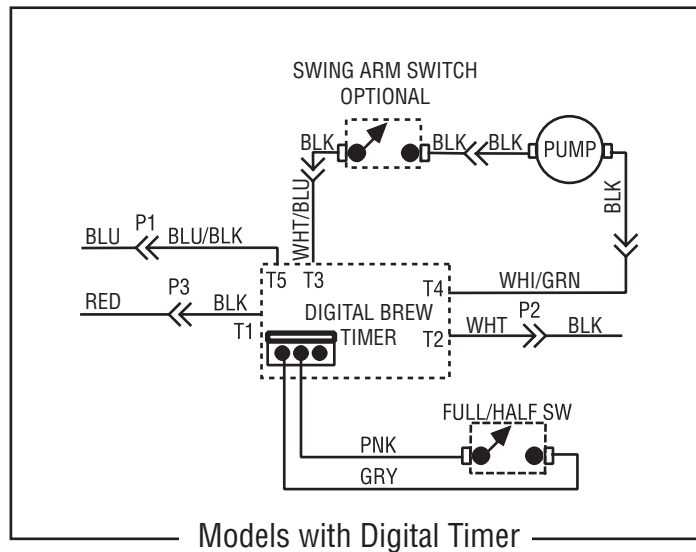
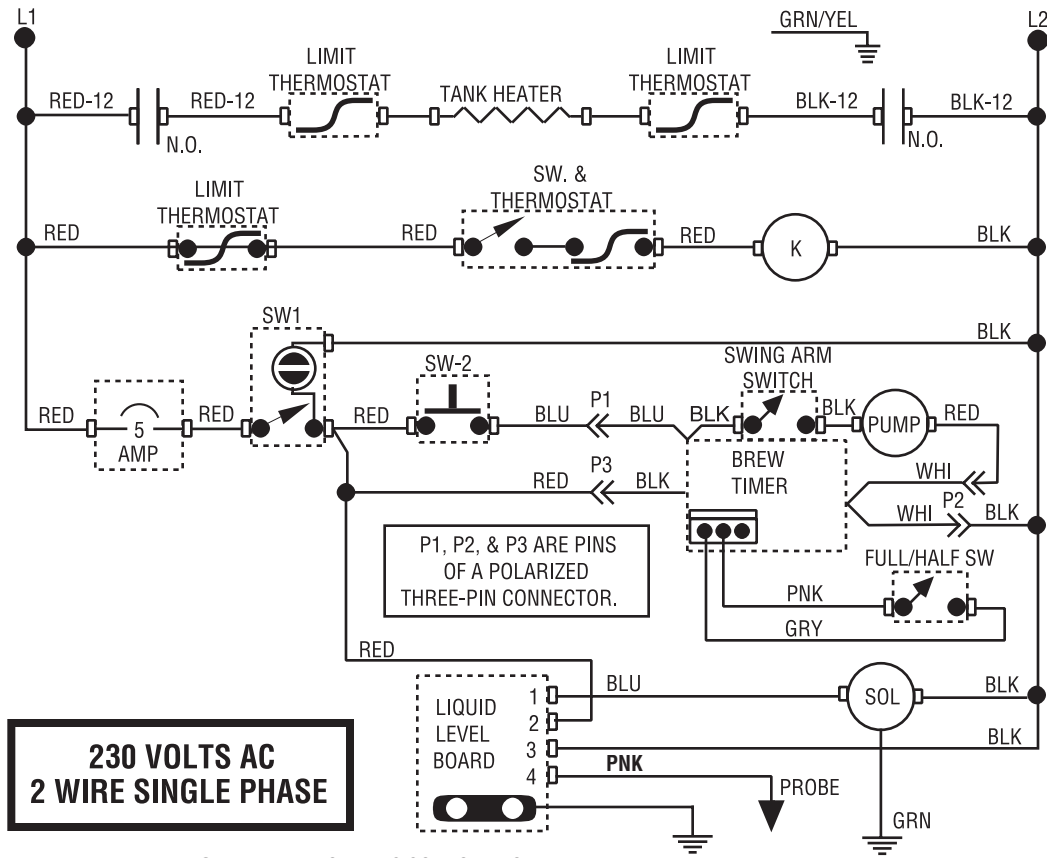

# SCHEMATIC WIRING DIAGRAM SRUA - CE

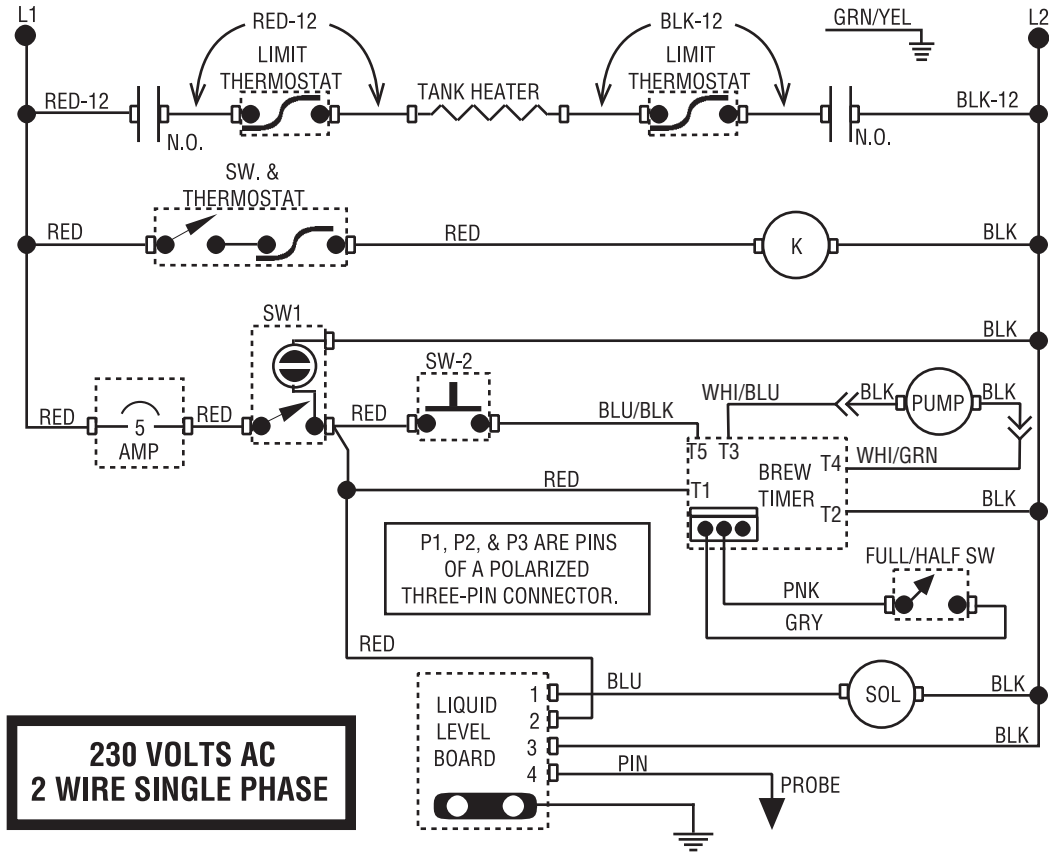

# SCHEMATIC WIRING DIAGRAM U3 & U38

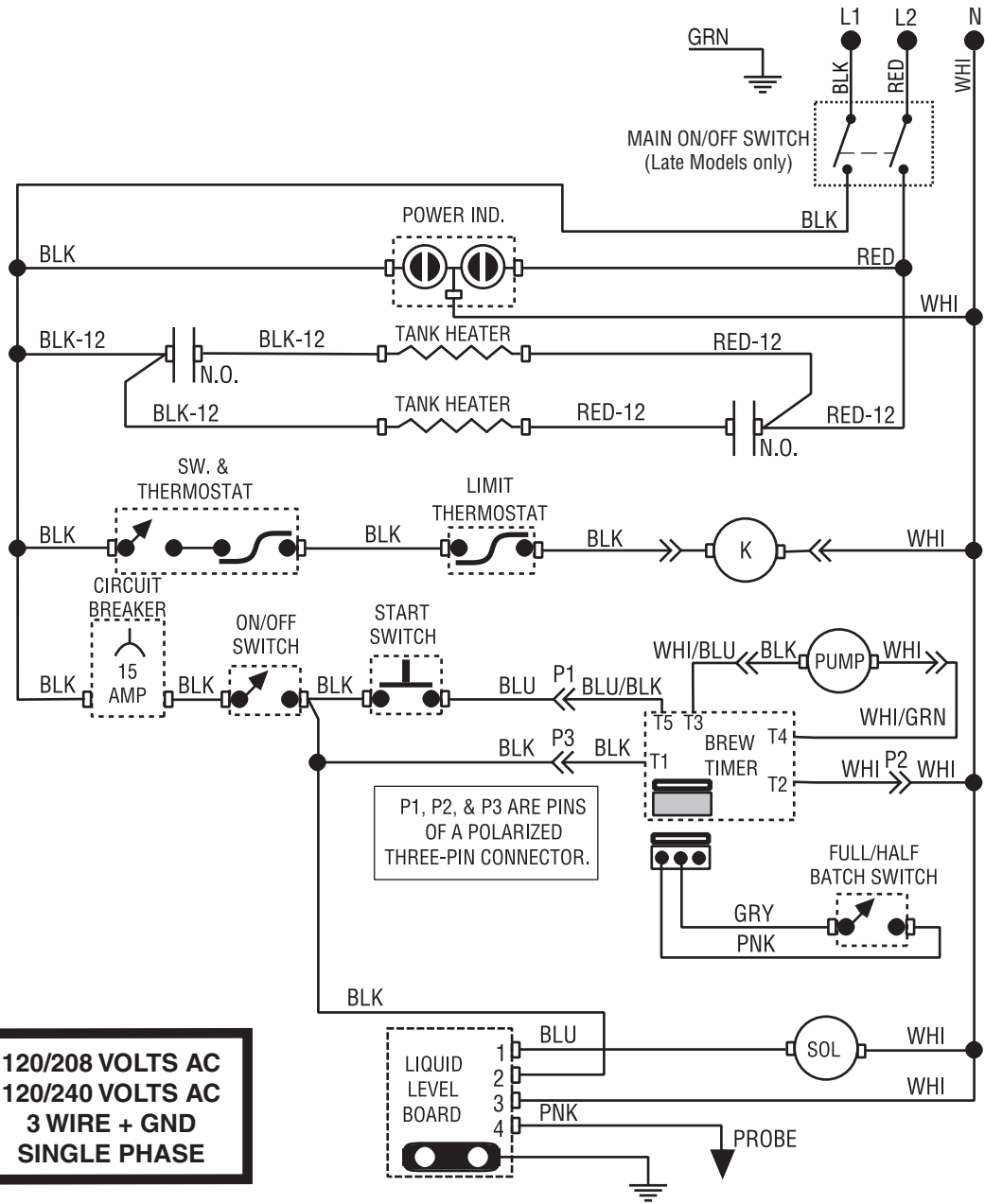

**120/208 VOLTS AC  
120/240 VOLTS AC  
3 WIRE + GND  
SINGLE PHASE**

10492.0000E 03/07 © 1990 BUNN-O-MATIC CORPORATION

# SCHEMATIC WIRING DIAGRAM U3A & U38A (BREWERS PRIOR TO U300004095)

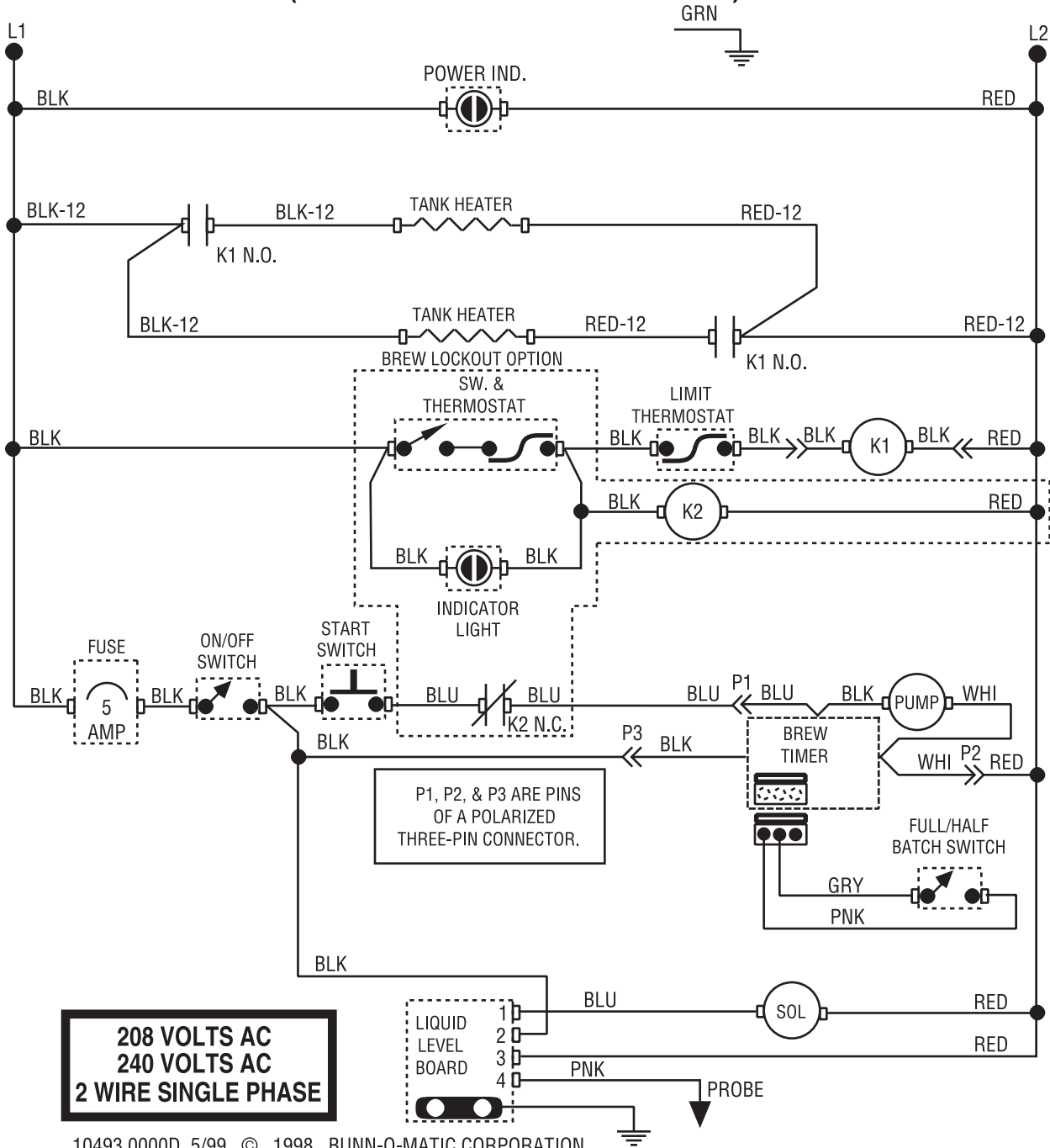

# SCHEMATIC WIRING DIAGRAM U3A - CE

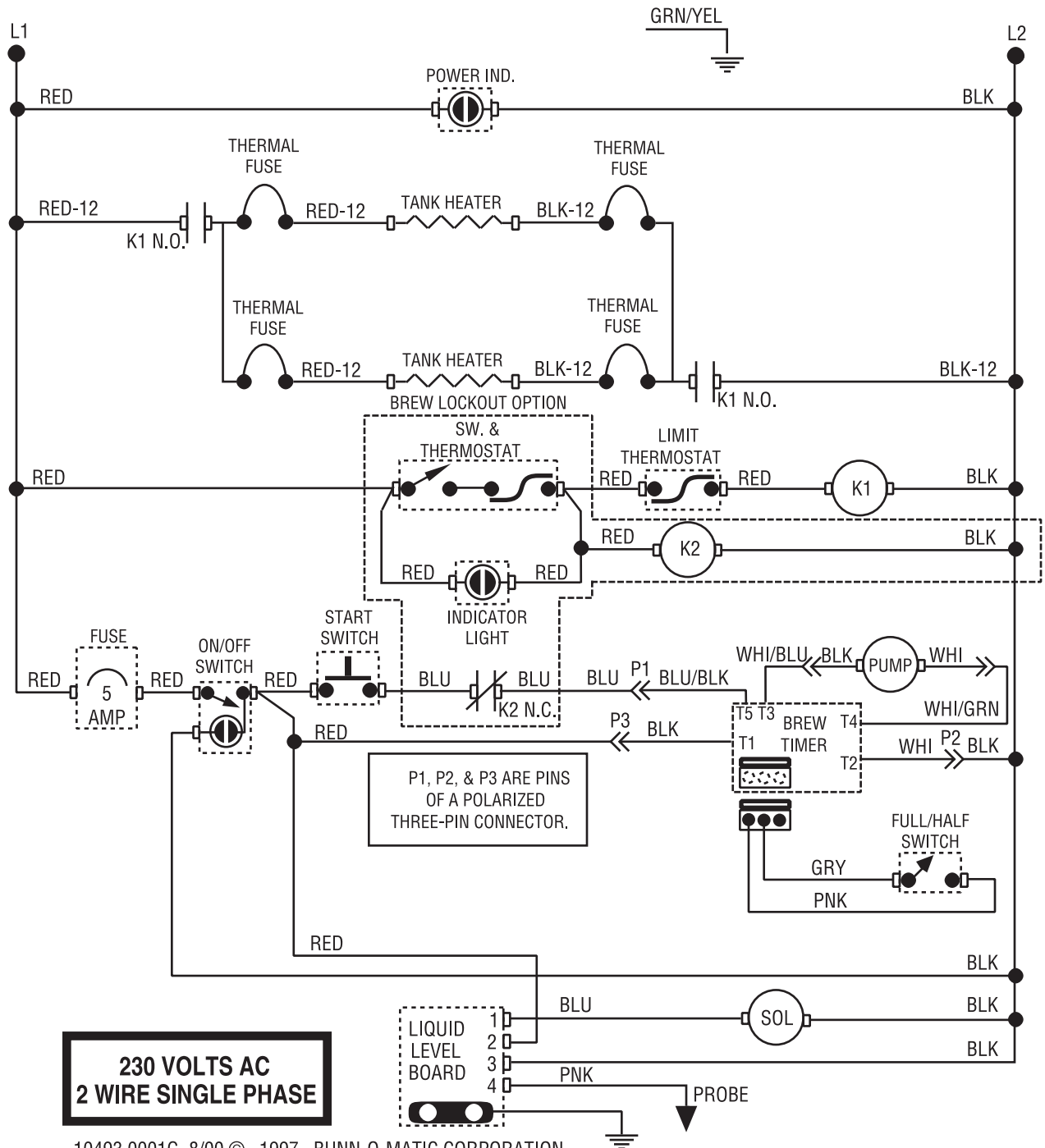

**230 VOLTS AC  
2 WIRE SINGLE PHASE**

10493.0001G 8/00 © 1997 BUNN-O-MATIC CORPORATION

# SCHEMATIC WIRING DIAGRAM U3A CE (KRAFT EUROPE)

- CONNECT BLUE WIRE TO L1 FOR CONNECTION TO SINGLE-PHASE 32 A SUPPLY
- CONNECT BLUE WIRE TO L2 FOR CONNECTION TO 3-PHASE 15 A SUPPLY

MAIN EARTH TERMINAL

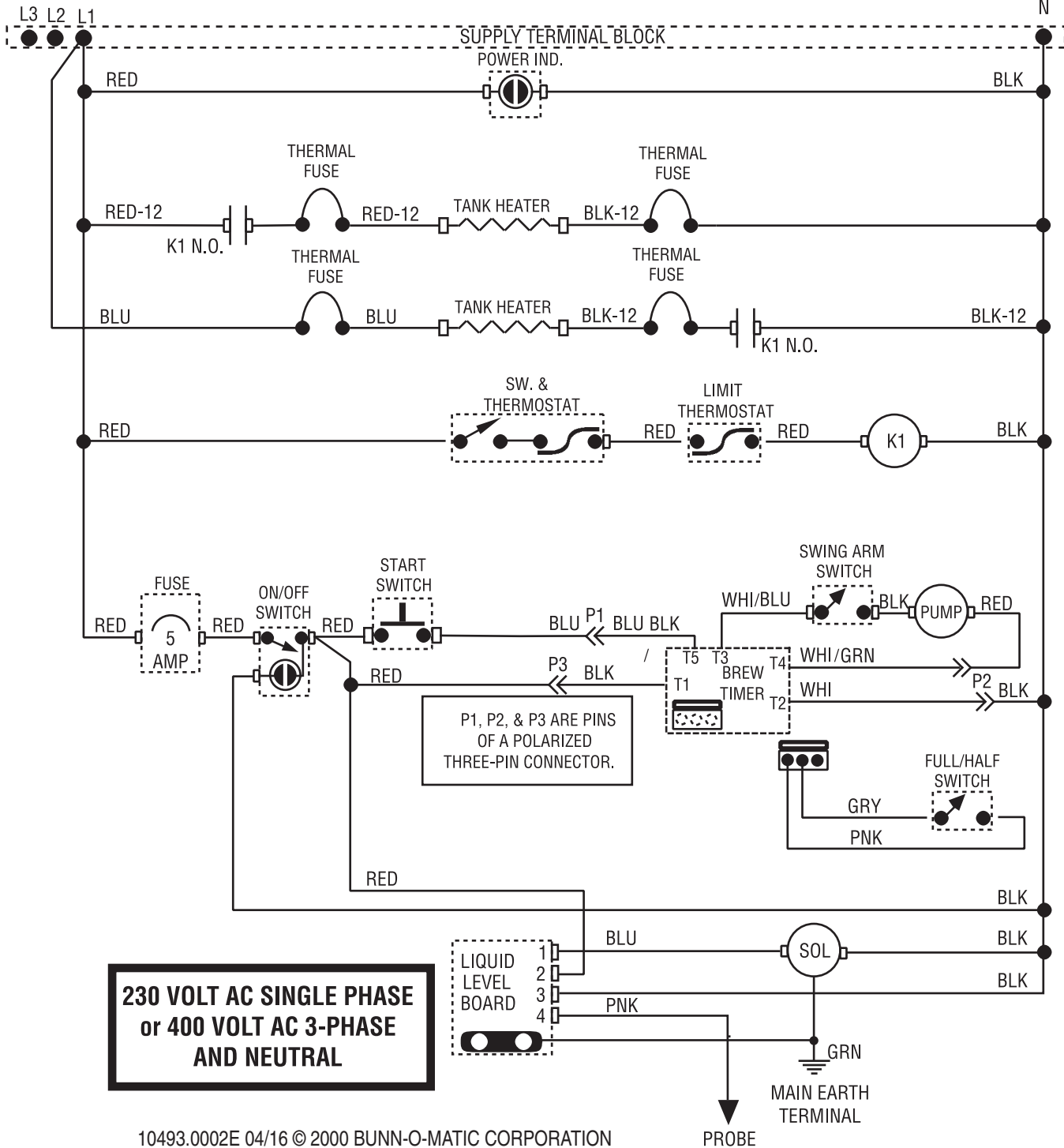

# SCHEMATIC WIRING DIAGRAM U3A CE

- CONNECT BLUE WIRE TO L1 FOR CONNECTION TO SINGLE-PHASE 32 A SUPPLY
- CONNECT BLUE WIRE TO L2 FOR CONNECTION TO 3-PHASE 15 A SUPPLY

MAIN EARTH TERMINAL

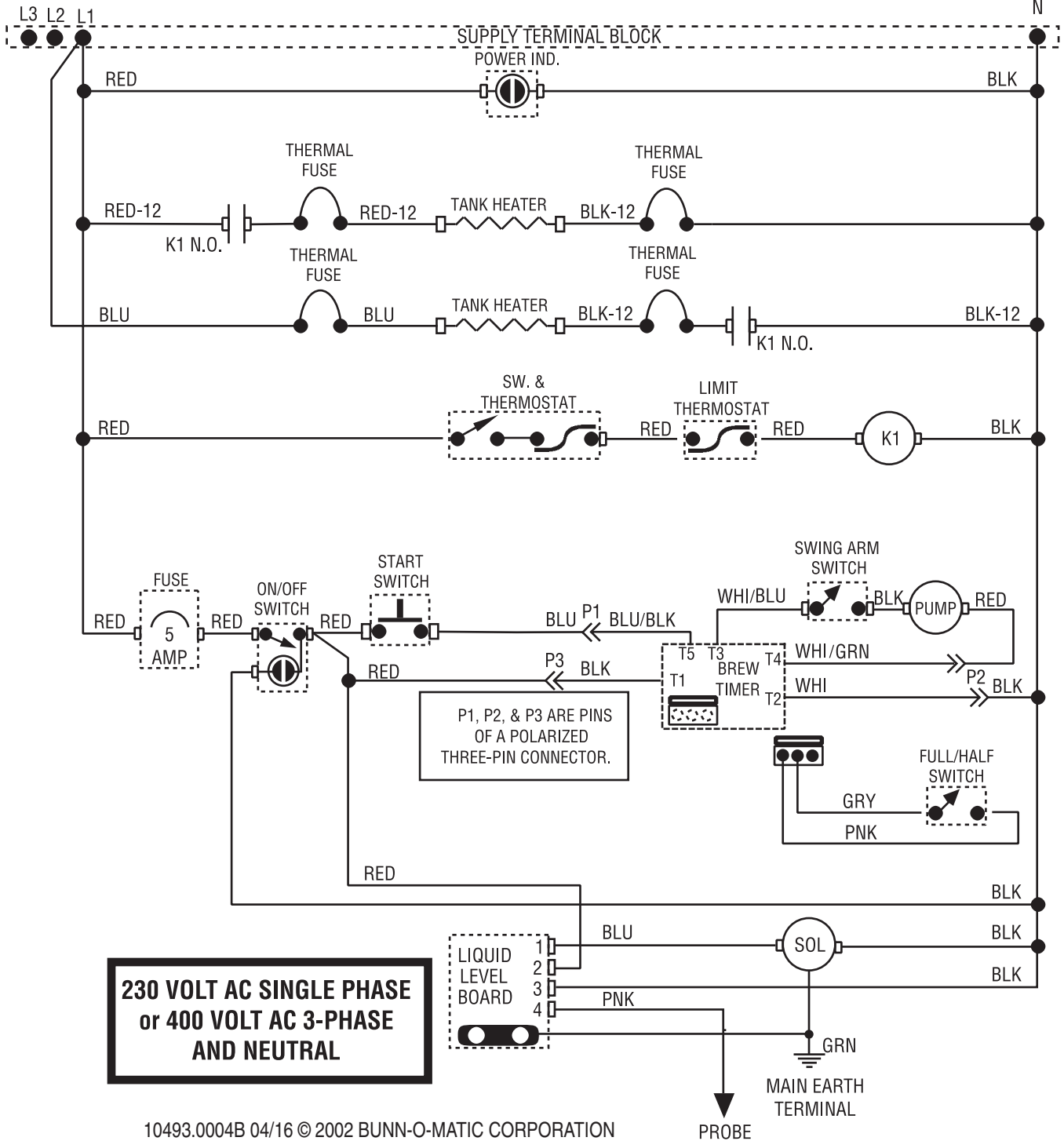

**230 VOLT AC SINGLE PHASE  
or 400 VOLT AC 3-PHASE  
AND NEUTRAL**

10493.0004B 04/16 © 2002 BUNN-O-MATIC CORPORATION

# SCHEMATIC WIRING DIAGRAM U3A CE

ALL WIRES 18 GAUGE UNLESS OTHERWISE SPECIFIED.  
 CONNECT BLUE WIRE TO L1 FOR CONNECTION TO SINGLE PHASE 32A SUPPLY.  
 CONNECT BLUE WIRE TO L2 FOR CONNECTION TO THREE PHASE 15A SUPPLY.

MAIN EARTH TERMINAL

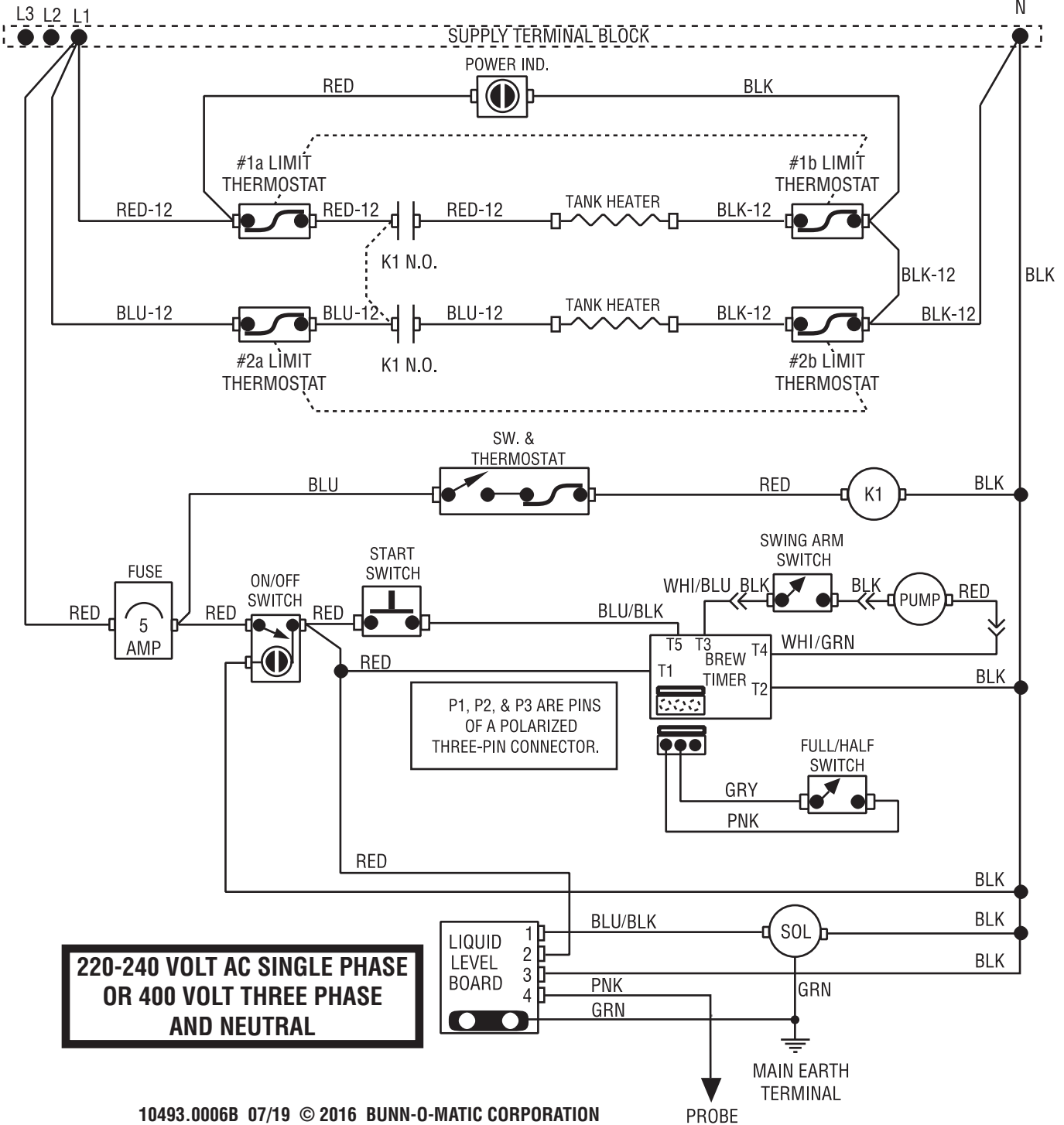

**220-240 VOLT AC SINGLE PHASE  
 OR 400 VOLT THREE PHASE  
 AND NEUTRAL**

10493.0006B 07/19 © 2016 BUNN-O-MATIC CORPORATION

PROBE

# SCHEMATIC WIRING DIAGRAM U333 & U3833

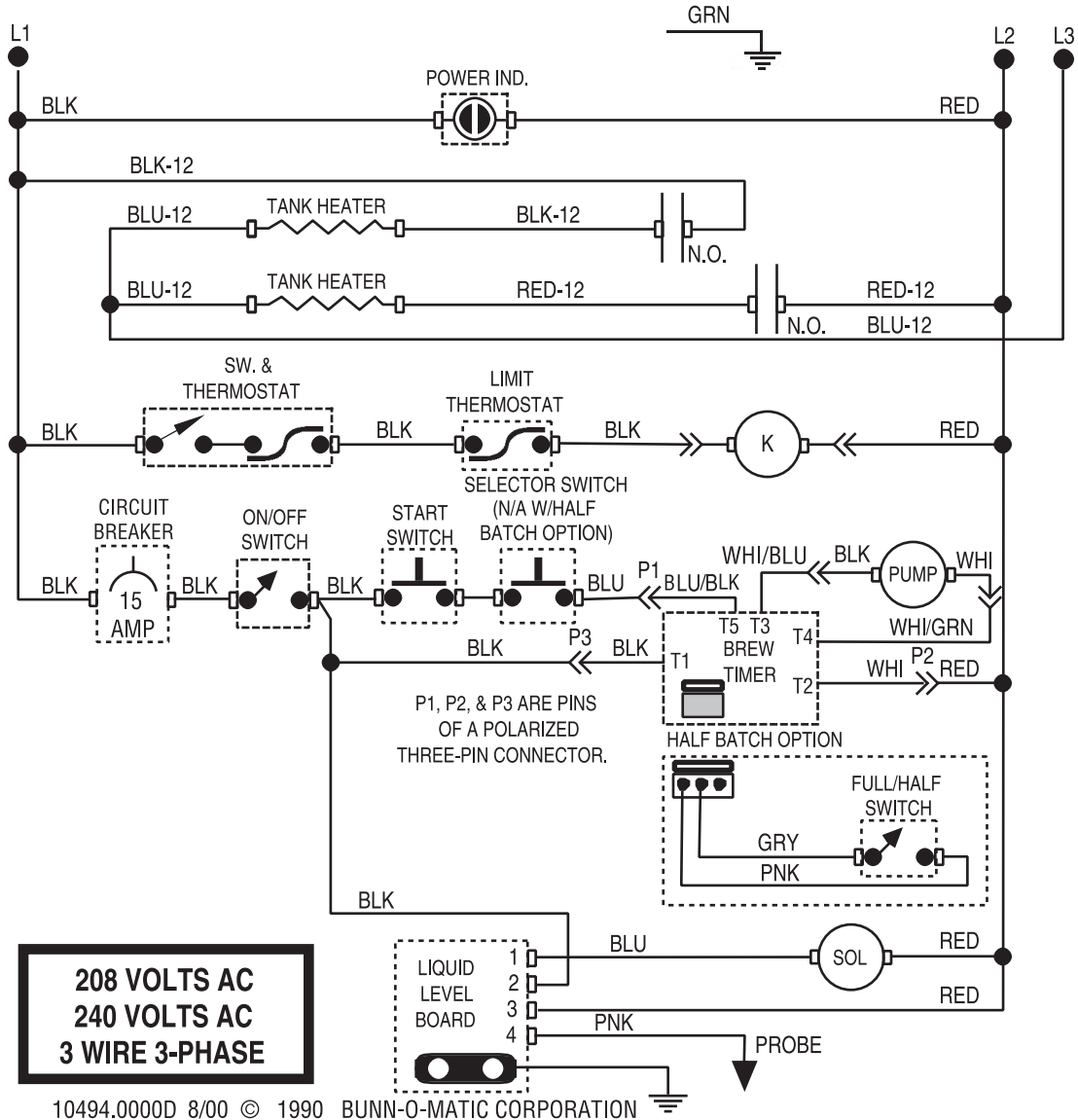

**208 VOLTS AC  
240 VOLTS AC  
3 WIRE 3-PHASE**

10494.0000D 8/00 © 1990 BUNN-O-MATIC CORPORATION

# SCHEMATIC WIRING DIAGRAM U3833

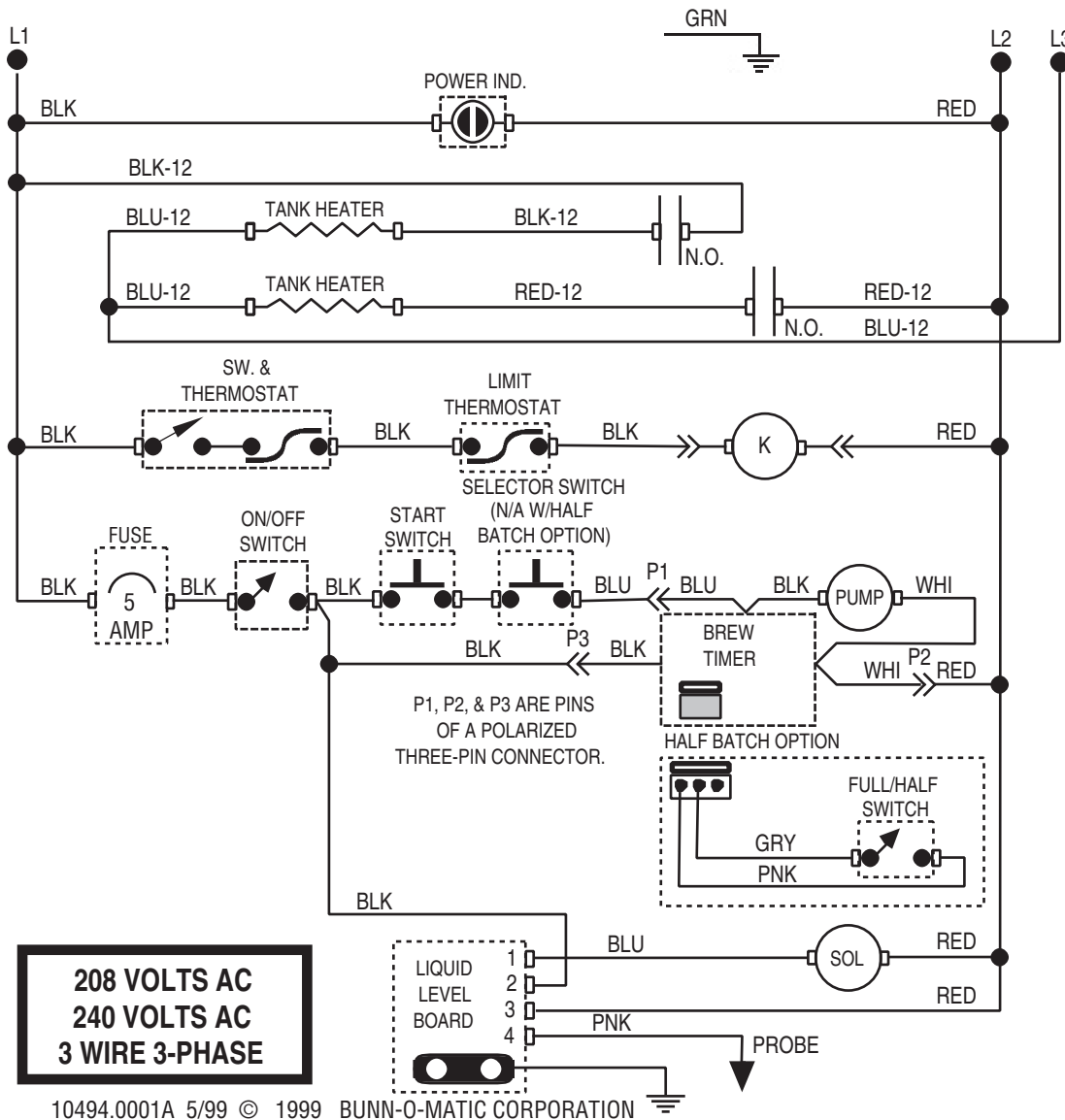

**208 VOLTS AC  
240 VOLTS AC  
3 WIRE 3-PHASE**

10494.0001A 5/99 © 1999 BUNN-O-MATIC CORPORATION

# SCHEMATIC WIRING DIAGRAM U3833

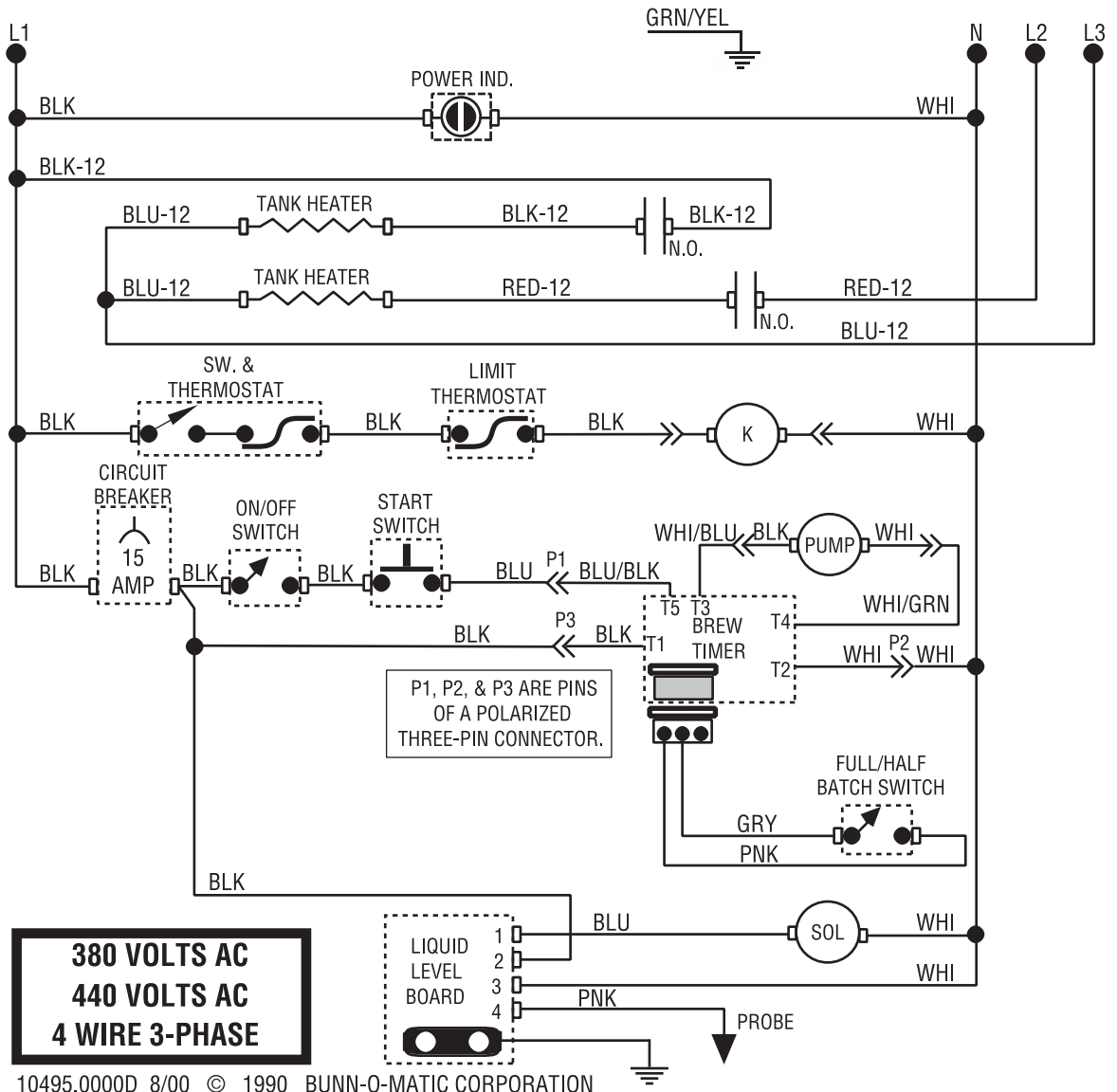

# SCHEMATIC WIRING DIAGRAM U3833

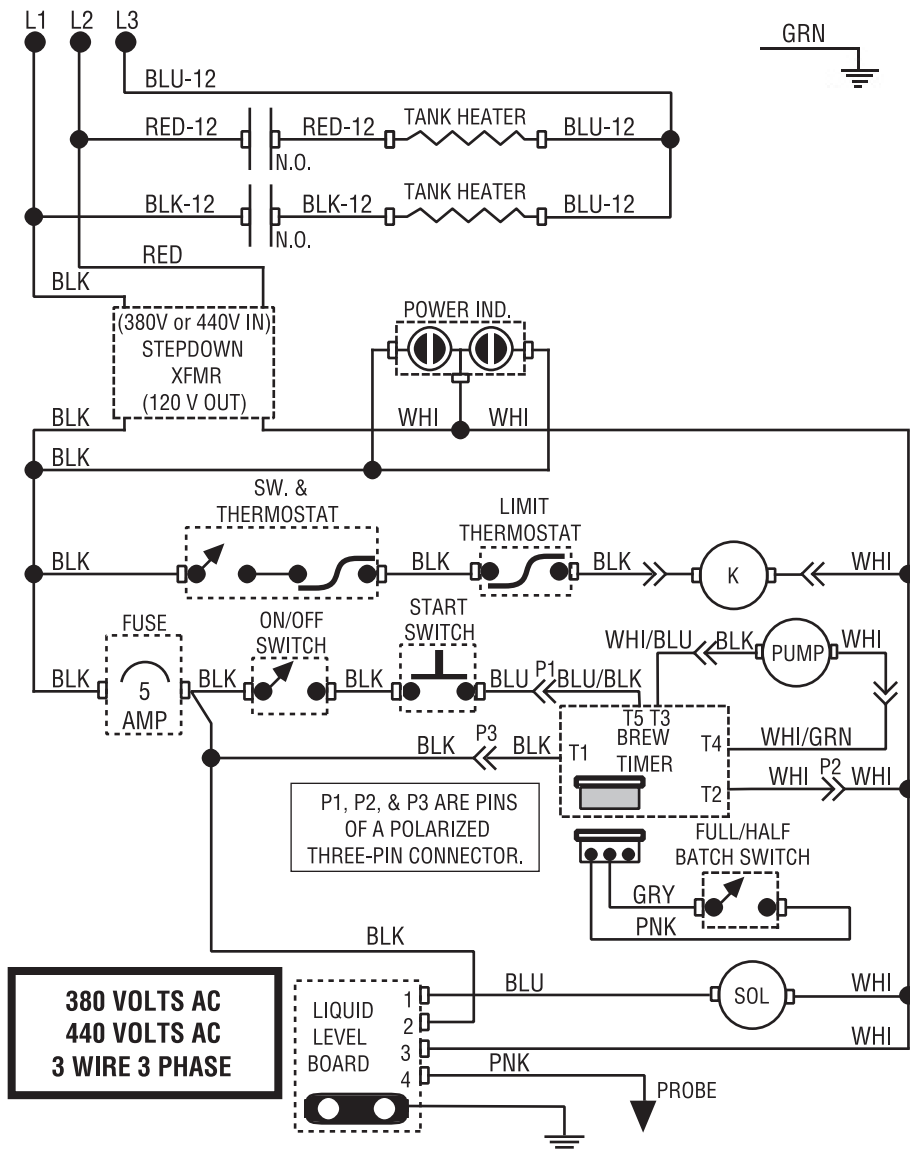

10495.0001E 8/00 © 1998 BUNN-O-MATIC CORPORATION