

BUNN®

AXIOM® SERIES

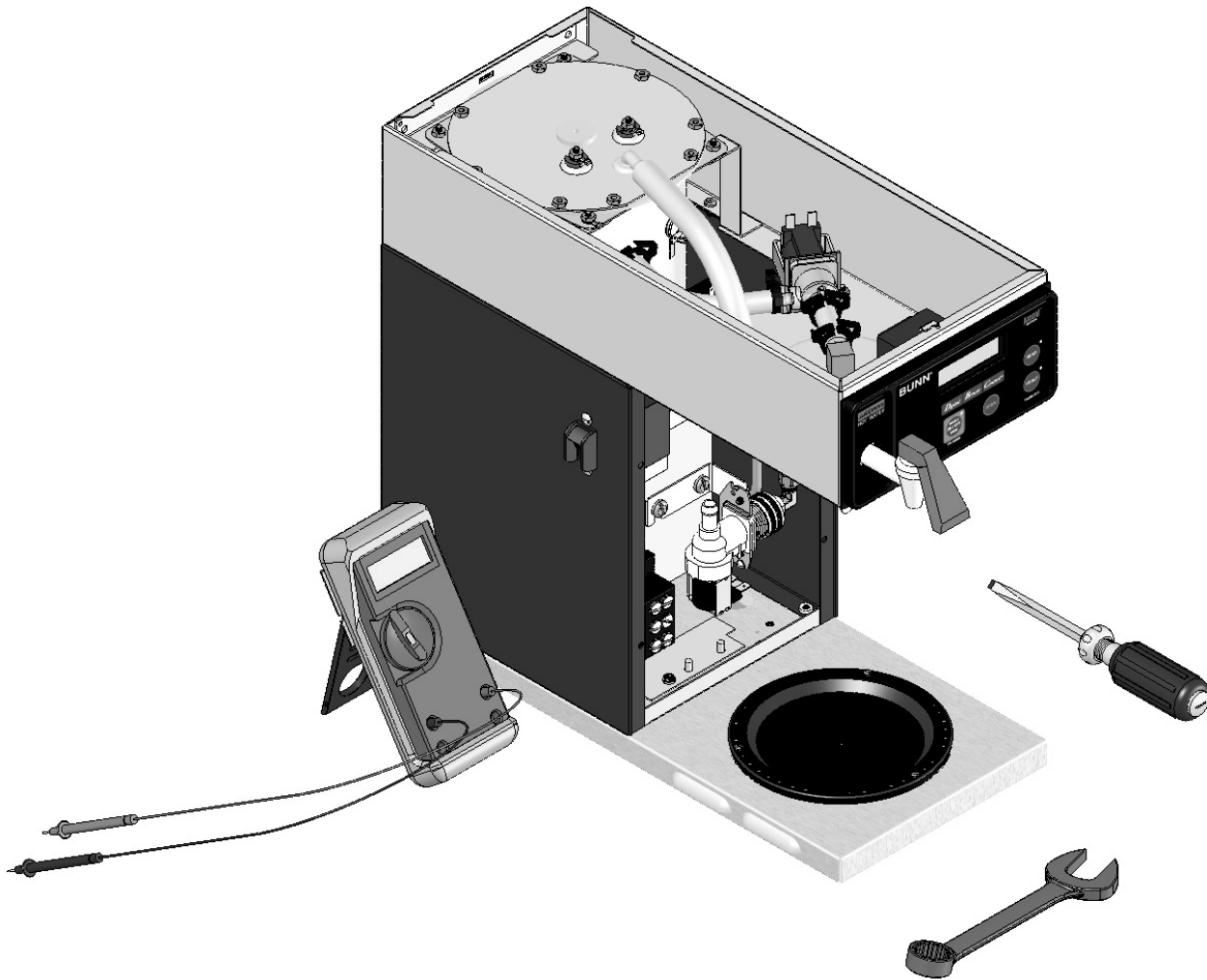

SERVICE & REPAIR MANUAL

BUNN-O-MATIC CORPORATION

POST OFFICE BOX 3227

SPRINGFIELD, ILLINOIS 62708-3227

PHONE: (217) 529-6601 FAX: (217) 529-6644

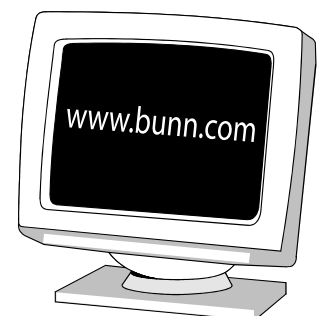

BUNN-O-MATIC COMMERCIAL PRODUCT WARRANTY

Bunn-O-Matic Corp. ("BUNN") warrants equipment manufactured by it as follows:

- 1) Airpots, thermal carafes, decanters, GPR servers, iced tea/coffee dispensers, MCR/MCP/MCA single cup brewers, thermal servers and ThermoFresh® servers (mechanical and digital) 1 year parts and 1 year labor.
- 2) All other equipment - 2 years parts and 1 year labor plus added warranties as specified below:
 - a) Electronic circuit and/or control boards - parts and labor for 3 years.
 - b) Compressors on refrigeration equipment - 5 years parts and 1 year labor.
 - c) Grinding burrs on coffee grinding equipment to grind coffee to meet original factory screen sieve analysis - parts and labor for 4 years or 40,000 pounds of coffee, whichever comes first.

These warranty periods run from the date of installation BUNN warrants that the equipment manufactured by it will be commercially free of defects in material and workmanship existing at the time of manufacture and appearing within the applicable warranty period. This warranty does not apply to any equipment, component or part that was not manufactured by BUNN or that, in BUNN's judgment, has been affected by misuse, neglect, alteration, improper installation or operation, improper maintenance or repair, non periodic cleaning and descaling, equipment failures related to poor water quality, damage or casualty. In addition, the warranty does not apply to replacement of items subject to normal use including but not limited to user replaceable parts such as seals and gaskets. This warranty is conditioned on the Buyer 1) giving BUNN prompt notice of

any claim to be made under this warranty by telephone at (217) 529-6601 or by writing to Post Office Box 3227, Springfield, Illinois 62708-3227; 2) if requested by BUNN, shipping the defective equipment prepaid to an authorized BUNN service location; and 3) receiving prior authorization from BUNN that the defective equipment is under warranty.

THE FOREGOING WARRANTY IS EXCLUSIVE AND IS IN LIEU OF ANY OTHER WARRANTY, WRITTEN OR ORAL, EXPRESS OR IMPLIED, INCLUDING, BUT NOT LIMITED TO, ANY IMPLIED WARRANTY OF EITHER MERCHANTABILITY OR FITNESS FOR A PARTICULAR PURPOSE. The agents, dealers or employees of BUNN are not authorized to make modifications to this warranty or to make additional warranties that are binding on BUNN. Accordingly, statements by such individuals, whether oral or written, do not constitute warranties and should not be relied upon.

If BUNN determines in its sole discretion that the equipment does not conform to the warranty, BUNN, at its exclusive option while the equipment is under warranty, shall either 1) provide at no charge replacement parts and/or labor (during the applicable parts and labor warranty periods specified above) to repair the defective components, provided that this repair is done by a BUNN Authorized Service Representative; or 2) shall replace the equipment or refund the purchase price for the equipment.

THE BUYER'S REMEDY AGAINST BUNN FOR THE BREACH OF ANY OBLIGATION ARISING OUT OF THE SALE OF THIS EQUIPMENT, WHETHER DERIVED FROM WARRANTY OR OTHERWISE, SHALL BE LIMITED, AT BUNN'S SOLE OPTION AS SPECIFIED HEREIN, TO REPAIR, REPLACEMENT OR REFUND.

In no event shall BUNN be liable for any other damage or loss, including, but not limited to, lost profits, lost sales, loss of use of equipment, claims of Buyer's customers, cost of capital, cost of down time, cost of substitute equipment, facilities or services, or any other special, incidental or consequential damages.

392, A Partner You Can Count On, Air Infusion, AutoPOD, AXIOM, BrewLOGIC, BrewMETER, Brew Better Not Bitter, BrewWISE, BrewWIZARD, BUNN Espresso, BUNN Family Gourmet, BUNN Gourmet, BUNN Pour-O-Matic, BUNN, BUNN with the stylized red line, BUNNlink, Bunn-O-Matic, Bunn-O-Matic, BUNNserve, BUNNSERVE with the stylized wrench design, Cool Froth, DBC, Dr. Brew stylized Dr. design, Dual, Easy Pour, EasyClear, EasyGard, FlavorGard, Gourmet Ice, Gourmet Juice, High Intensity, iMIX, Infusion Series, Intellisteam, My Café, Phase Brew, PowerLogic, Quality Beverage Equipment Worldwide, Respect Earth, Respect Earth with the stylized leaf and coffee cherry design, Safety-Fresh, savemycoffee.com, Scale-Pro, Silver Series, Single, Smart Funnel, Smart Hopper, SmartWAVE, Soft Heat, SplashGard, The Mark of Quality in Beverage Equipment Worldwide, ThermoFresh, Titan, trifacta, TRIFECTA (stylized logo), Velocity Brew, Air Brew, Beverage Bar Creator, Beverage Profit Calculator, Brew better, not bitter., Build-A-Drink, BUNNSource, Coffee At Its Best, Cyclonic Heating System, Daypart, Digital Brewer Control, Element, Milk Texturing Fusion, Nothing Brews Like a BUNN, Picture Prompted Cleaning, Pouring Profits, Signature Series, Sure Tamp, Tea At Its Best, The Horizontal Red Line, Ultra are either trademarks or registered trademarks of Bunn-O-Matic Corporation. The commercial trifacta® brewer housing configuration is a trademark of Bunn-O-Matic Corporation.

CONTENTS

Troubleshooting	4
Diagnostics	9
Technician Programming Reminders	10
Access	11
Control Board.....	12
Face Plate.....	13
Membrane Switch	13
Brew Valve	14
Optional Brew Valve	15
Level Probes	16
Early Refill Valve	17
Later Refill Valve	18
Tank Heaters	20
Limit Thermostat.....	21
Thermal Cut Off.....	21
Blanket Warmer	22
Temperature Probe.....	23
Warmer Elements.....	24
Voltage Selector Switch	25
Power Switch.....	26
Programming Level 3.....	27
Programming Level 4.....	29
Wiring Diagrams	30
Schematics	34

TROUBLESHOOTING

A troubleshooting guide is provided to suggest probable causes and remedies for the most likely problems encountered. If the problem remains after exhausting the troubleshooting steps, contact the Bunn-O-Matic Technical Service Department.

- Inspection, testing, and repair of electrical equipment should be performed only by qualified service personnel.
- All electronic components have ac line voltage and some have low voltage dc potential on their terminals. Shorting of terminals or the application of external voltages may result in board failure.
- Intermittent operation of electronic circuit boards is unlikely. Board failure will normally be permanent. If an intermittent condition is encountered, the cause will likely be a switch contact or a loose connection at a terminal or crimp.
- Solenoid removal requires interrupting the water supply to the valve. Damage may result if solenoids are energized for more than ten minutes without a supply of water.
- The use of two wrenches is recommended whenever plumbing fittings are tightened or loosened. This will help to avoid twists and kinks in the tubing.
- Make certain that all plumbing connections are sealed and electrical connections tight and isolated.
- This brewer is heated at all times. Keep away from combustibles.

WARNING

- **Exercise extreme caution when servicing electrical equipment.**
- **Unplug the brewer when servicing, except when electrical tests are specified.**
- **Follow recommended service procedures.**
- **Replace all protective shields or safety notices.**

Before assuming a faulty control board, check for the following:

Control Boards

1. Make sure ribbon cable is properly attached to the control board (ALL PINS INSERTED INTO PLUG).
2. Make sure there is a nylon insulating washer under each screw head that holds the control board to the plastic front end cap. This is important for proper operation.
3. Make sure, before servicing brewer that voltage is present at control board.
4. Press any warmer switch (if equipped) or observe if any indicator lights are glowing on the control panel. If so, proceed with testing. If not, check for voltage across pins 1 & 2 of the ten pin J1 connector (black and white wires). If voltage is present, replace the control board. If voltage is not present, check wiring and voltage across terminal block (black and white on 120 & 120/240 models, or black and red on A models). Correct the problem and retest before proceeding with testing.

TROUBLESHOOTING (cont.)

REFILL CIRCUIT

PROBLEM	PROBABLE CAUSE	REMEDY
Will not refill	1. Power off to brewer	Press OFF/ON switch on control panel to determine if power is ON.
	2. Water shut off	Make sure water is ON.
	3. Error Message	Brewer has shut down due to malfunction (See Diagnostic Section in this manual).
	4.ON/OFF Switch (If equipped)	Make sure ON/OFF Switch is "ON" and indicator is lit.
	5. Lime build up on Probe(s)	Remove the Level Probe(s) and check for lime deposit on tip. Clean and reinstall.
	6. Refill Valve or Control Board	Refer to page 19
Refill does not shut off Power "ON"	1. Lime build up on probe	Remove Level Probe and check for lime deposits on tip. Clean and reinstall.
	2. Water Level Sensing System	Replace control board
	3. Refill valve or control board	Check valve. Page 19
Refill does not shut off Power "OFF"	1. Refill valve	Clean or replace valve as needed. Page 19

TROUBLESHOOTING (cont.)

HEATING CIRCUIT

PROBLEM

Water does not heat to proper temperature

IMPORTANT: Make sure no temperature tests are taken before the display reads ready. Tank temperature must be stabilized before readings are taken.

PROBABLE CAUSE

1. Display's error message
2. Water not touching main (short) level probe
3. Water Level Probe Sensing System
4. Temperature Probe
5. Limit Thermostat or TCO
6. Tank Heater

REMEDY

Brewer has shut down due to malfunction. See Diagnostics.

Remove level probe and grommet. Look into hole on tank lid. Water must be within approximately one inch from top of tank.

Check refill circuit. Heaters will not turn on if water is not grounding level probe.

Check/replace

Check/replace

Check/replace

Spitting or excessive steaming (cont.)

1. Lime build up on temperature probe, tank or tank heater
2. Temperature Probe
3. Control Board

Inspect probe and tank assembly for excessive lime deposits. Delime as required.

Check/replace

Check/replace

Brewer is making unusual noises

1. Plumbing lines
2. Water supply
3. Lime build up

Plumbing lines should not rest on the counter top.

The brewer must be connected to a cold water supply.

Remove the tank lid and clean inside of tank with a deliming agent, if necessary.

TROUBLESHOOTING (cont.)
BREWING CIRCUIT

PROBLEM	PROBABLE CAUSE	REMEDY
Brew cycle will not start	1. Display's error message	Brewer has shut down due to malfunction. See Diagnostics.
	2. No water	Water lines and valves to the brewer must be open.
	3. No power or incorrect voltage to the brewer	Check for voltage across the terminals at the terminal block.
	4. ON/OFF switch not in the "ON" position	The indicator lamp must be lit
	5. Low water temperature (Brew lockout is enabled)	Allow brewer to heat until ready, or disable the brew lockout feature.
	6. Water not touching refill probe inside tank	Water must be in contact with refill probe before brew cycle will start. Check/replace
	7. Membrane Switch	Check/replace
	8. Dispense valve	Check/replace
	9. Control board	Inspect the dispense valve and sprayhead for excessive lime deposits. Delime as required.
Consistently low beverage level in the dispenser or beverage overflows dispenser	1. Brew volume NOTE: Volume adjustments must be made with sprayhead installed.	Remove dispense valve and clear any obstructions. Rebuild or replace valve if necessary. (See page 24) Check/replace
	2. Lime build up	Delime as required.
	3. Dispense Valve	Ensure mylar shield(s) are installed on top cover
Brew cycle starts, then aborts and returns to Main screen after 20 seconds (SB 153)	1. Level probes shorted	Instruct operator to use one procedure but not both
	2. On pour over models, the operator poured in water and pressed the start button	

TROUBLESHOOTING (cont.)

BREWING CIRCUIT (cont.)

PROBLEM	PROBABLE CAUSE	REMEDY
Dripping from sprayhead	1. Lime build up	Inspect the tank assembly for excessive lime deposits. Delime as required.
	2. Dispense valve	Check/replace
Weak beverage	1. Sprayhead	A clean sprayhead must be used for proper extraction.
	2. Water temperature	Place an empty brew funnel on an empty decanter beneath the sprayhead. Initiate brew cycle and check the water temperature immediately below the sprayhead with a thermometer. The reading must not be less than 195°F (91°C). Adjust the temperature setting to increase the water temperature. Refer to Initial Set-up instructions.
	3. Filter type	BUNN® paper filters must be used for proper extraction.
	4. Coffee grind	A fine drip or grind must be used for proper extraction.
	5. Funnel loading	The BUNN® paper filter must be centered in the funnel and the bed of grounds leveled by shaking gently.
Dry coffee grounds remain in the funnel	1. Sprayhead	Make sure sprayhead is present and holes are clear and unobstructed.
	2. Funnel loading	The BUNN® paper filter must be centered in the funnel and the bed of grounds leveled by shaking gently.
Low beverage serving temperature	1. Warmer	Check/replace
	2. Thermal server/AirPot not preheated before brew cycle	Preheat server

DIAGNOSTICS

MESSAGE	PROBABLE CAUSE	REMEDY
"CHECK SPRAYHEAD FOR LIME" - "CHECK FITTINGS FOR LIME"	1. Lime buildup in sprayhead 2. Lime buildup in brew valve 3. Lime buildup in brew tank	Clean sprayhead Clean valve Clean tank
"WARNING INACCURATE FLOW" - "TOO MUCH LIME PLEASE RE- PAIR"	1. Lime buildup in sprayhead 2. Lime buildup in brew valve 3. Lime buildup in brew tank	Clean sprayhead Clean valve Clean tank
"WARNING VERY LOW FLOW" - "PLEASE REPAIR"	1. Lime buildup in sprayhead 2. Lime buildup in brew valve 3. Lime buildup in brew tank	Clean sprayhead Clean valve Clean tank
Temperature Too Low	1. Water temperature in the tank does not meet the ready temperature.	A) Wait for the brewer to heat to the proper temperature. B) Disable the BREW LOCKOUT function. Refer to programming section for procedure.
Heating Time Too Long	1. Tank Heater failure. 2. Control Board/Thermistor failure	Replace or repair as needed Replace or repair as needed
Fill Time Too Long	1. Water shut off to brewer 2. Supply line too small or obstructed 3. Inlet Solenoid failure 4. Control Board Failure 5. ON/OFF switch is OFF	Check water supply shut-off Replace or repair as needed Replace or repair as needed Replace or repair as needed Turn switch ON
Temp Sensor Out Of Range, Check For Bad Connections	1. Temperature Sensor Probe open	Replace or repair as needed
Temp Sensor Out Of Range, Check Wire For Shorts	1. Temperature Sensor Probe wire(s) shorted	Replace or repair as needed

TECHNICIAN PROGRAMMING REMINDERS

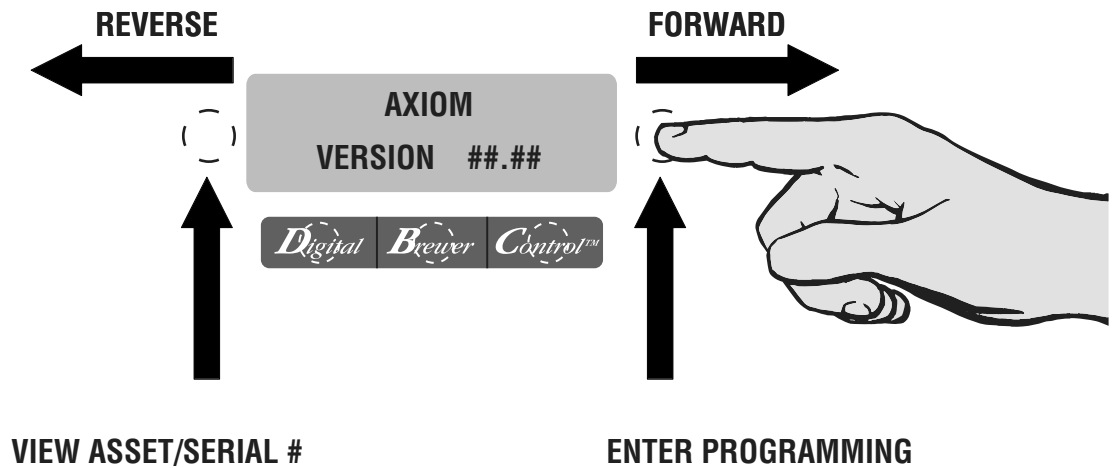

ACCESSING PROGRAM MODES

Press and hold the right hidden switch. The longer you press it, the higher the level you can access. EXAMPLE: Pressing for a couple seconds enters Level 1. Continuing to press for approximately 5 seconds will access Level 2. Continue pressing for approximately 15 seconds to access Level 3. During program modes, use the right hidden switch to advance forward through screens. Use left hidden switch to step backwards through screens.

VIEWING ASSET AND SERIAL NUMBERS

Press left hidden switch to view Asset number. Press and release to view serial number. Press and release again to view the installed software version.

FACTORY BLOWOUT MODE

When in the main screen, DO NOT press both left and right hidden switches at the same time. The display will read "FACTORY BLOWOUT" "ON/OFF". **WARNING: NEVER activate this mode. It will open the brew and refill valves simultaneously. THIS IS FOR FACTORY USE ONLY! If you accidentally enter this screen, exit out of it by pressing the "ENABLE BREW ON/OFF" switch.**

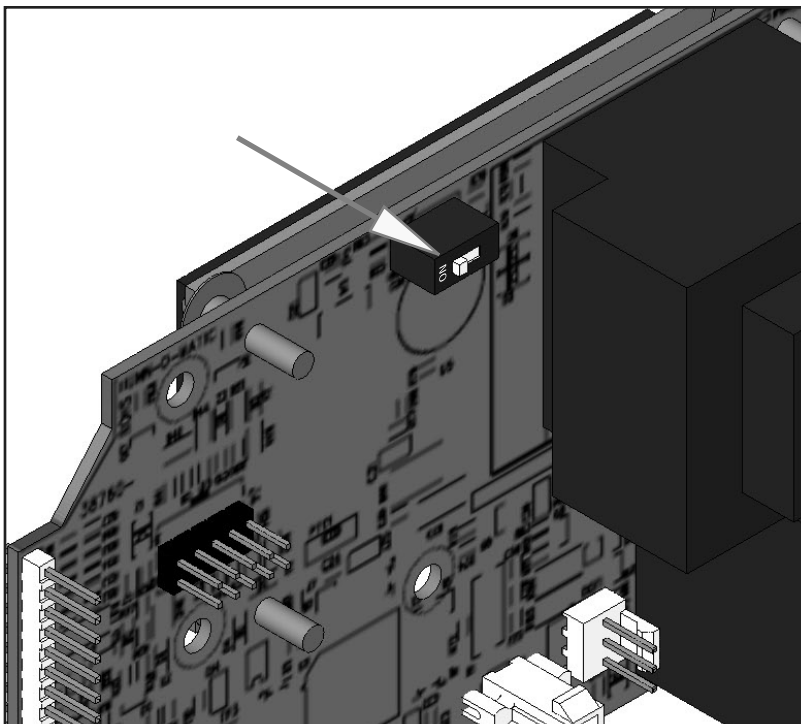

PROGRAMMING LOCKOUT SWITCH (Mounted on main control board)

This switch can be set to prevent access to Level 2. Turn "OFF" the switch to access Technician (Level 2). Once all the correct brew settings are programmed, the Technician can set the switch to the "ON" position to prohibit anyone from changing the settings. With the switch in the "ON" position, only Level 1 can be accessed by store personnel. Technicians can access Level 1 with the switch in either position. To enter Levels 2, 3, & 4, press and hold right hidden switch.

COMPONENT ACCESS

This section provides procedures for testing and replacing various major components used in this brewer should service become necessary. Refer to Troubleshooting for assistance in determining the cause of any problem.

WARNING - Inspection, testing, and repair of electrical equipment should be performed only by qualified service personnel. The brewer should be unplugged when servicing, except when electrical tests are required and the test procedure specifically states to plug in the brewer.

WARNING - Disconnect the brewer from the power source before the removal of any panel or the replacement of any component.

All components are accessible by the removal of the top cover or warmer housing, front access panel and warmer plate(s).

Refer to wiring diagrams at the back of this manual when reconnecting wires.

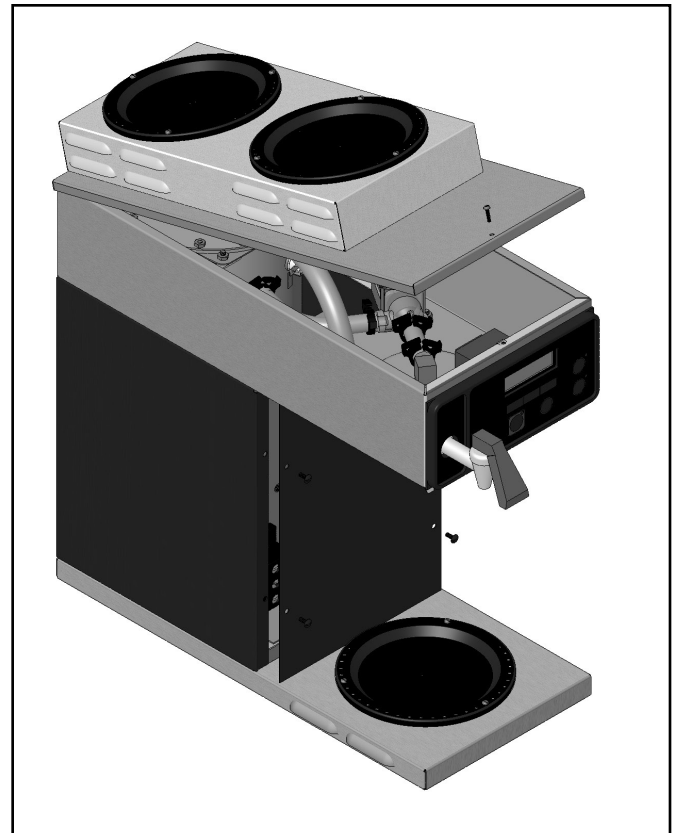

FIG. 11-1 COMPONENT ACCESS

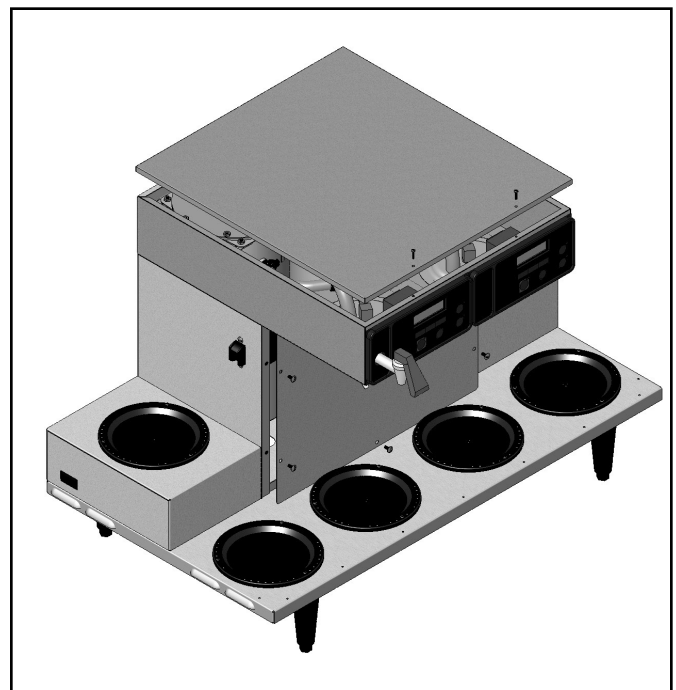

FIG. 11-2 COMPONENT ACCESS

CONTROL BOARD

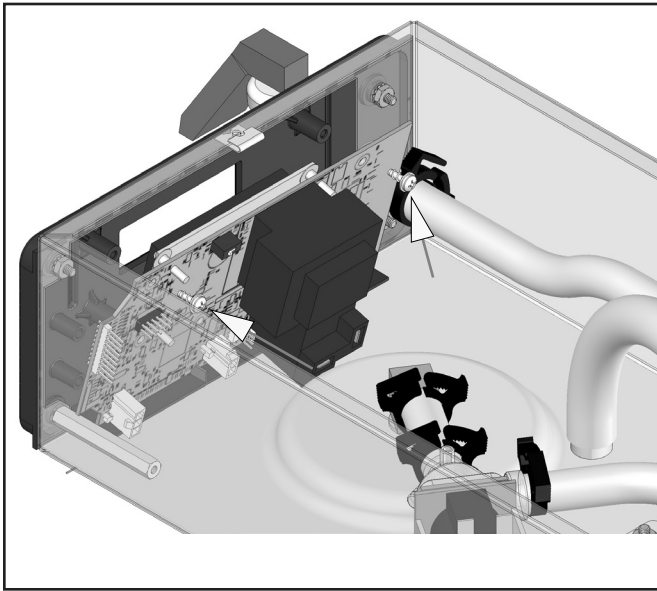

FIG. 12-1 CONTROL BOARD

Location:

The Control Board is located inside the top cover behind the front face plate.

Test Procedures:

The test procedures for the control board will vary depending upon the problems experienced by the brewer. Refer to the Troubleshooting section which is divided into three sections, Refill Circuit, Heating Circuit, and Brewing Circuit.

Check for Power to board:

1. Insert one meter lead in J1-pin 1 and the other lead in J1-pin 2.
2. With the power connected to brewer, the voltage reading to the board should be the line voltage rated for that model.

**If no voltage is present, check wiring to the board.
If voltage is present, and brewer does not power on, replace board.**

Removal and Replacement:

1. Disconnect brewer from power source.
2. Disconnect the wires from the relay on the control board.
3. Disconnect the 10-pin connector (main harness) and the 3-pin connector (level probe harness) from the control board.
4. Disconnect the 10-pin connector (ribbon cable) from the control board.

5. Remove the two screws and two nylon washers securing the control board to the front face plate.
6. Tilt the control board inward to clear the display section.

7. Place the bottom edge of the new control board in the two cradles, tilt the board forward, and secure with the two screws and nylon washers to the front face plate.

NOTE: The nylon washers must be installed under the heads of the two screws to prevent a possible shorting of the control board circuits.

8. Re-install wires & connectors.

BEFORE REPLACEMENT:

If a triac or MOV is visibly burned, it was most likely caused by an external sources such as a shorted wire or damaged solenoid coil. Use the triac map below to trace the circuit in question, and repair/replace the component before replacing control board.

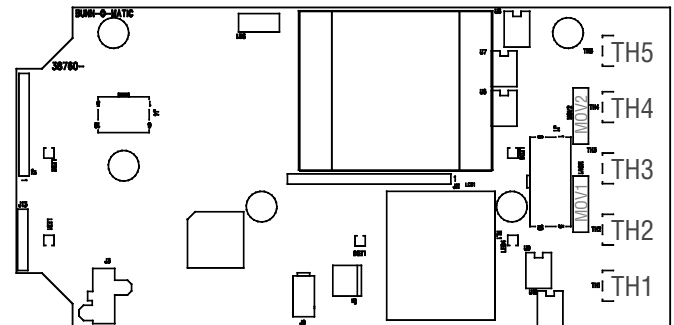

FIG. 12-2 TRIACS

Triac Map:

TH1	Warmer	@ J1-7
TH2/MOV-1	Brew solenoid	@ J1-10
TH3	Warmers	@ J1-4&8
TH4/MOV-2	Refill solenoid	@ J1-5
TH5	Main warmer	@ J1-6

FACEPLATE REMOVAL

Faceplate Removal and Replacement:

1. Disconnect brewer from power source.
2. Disconnect the wires from the relay on the control board.
3. Disconnect the 10-pin connector (main harness) and the 3-pin connector (level probe harness) from the control board.
4. Disconnect the 10-pin connector (ribbon cable) from the control board.
5. Drain tank and disconnect/remove faucet.
6. Remove the 3 nuts and 1 standoff from back side of faceplate assembly.
7. Remove faceplate and control board as an assembly out the front opening.

8. Remove the two screws and two nylon washers securing the control board to the front face plate.
9. Place the bottom edge of the new control board in the two cradles and secure with the two screws and nylon washers to the front face plate.

NOTE: The nylon washers must be installed under the heads of the two screws to prevent a possible shorting of the control board circuits.

10. Re-install faucet assembly (if equipped).
11. Re-install faceplate/board assembly.
12. Re-install wires & connectors.

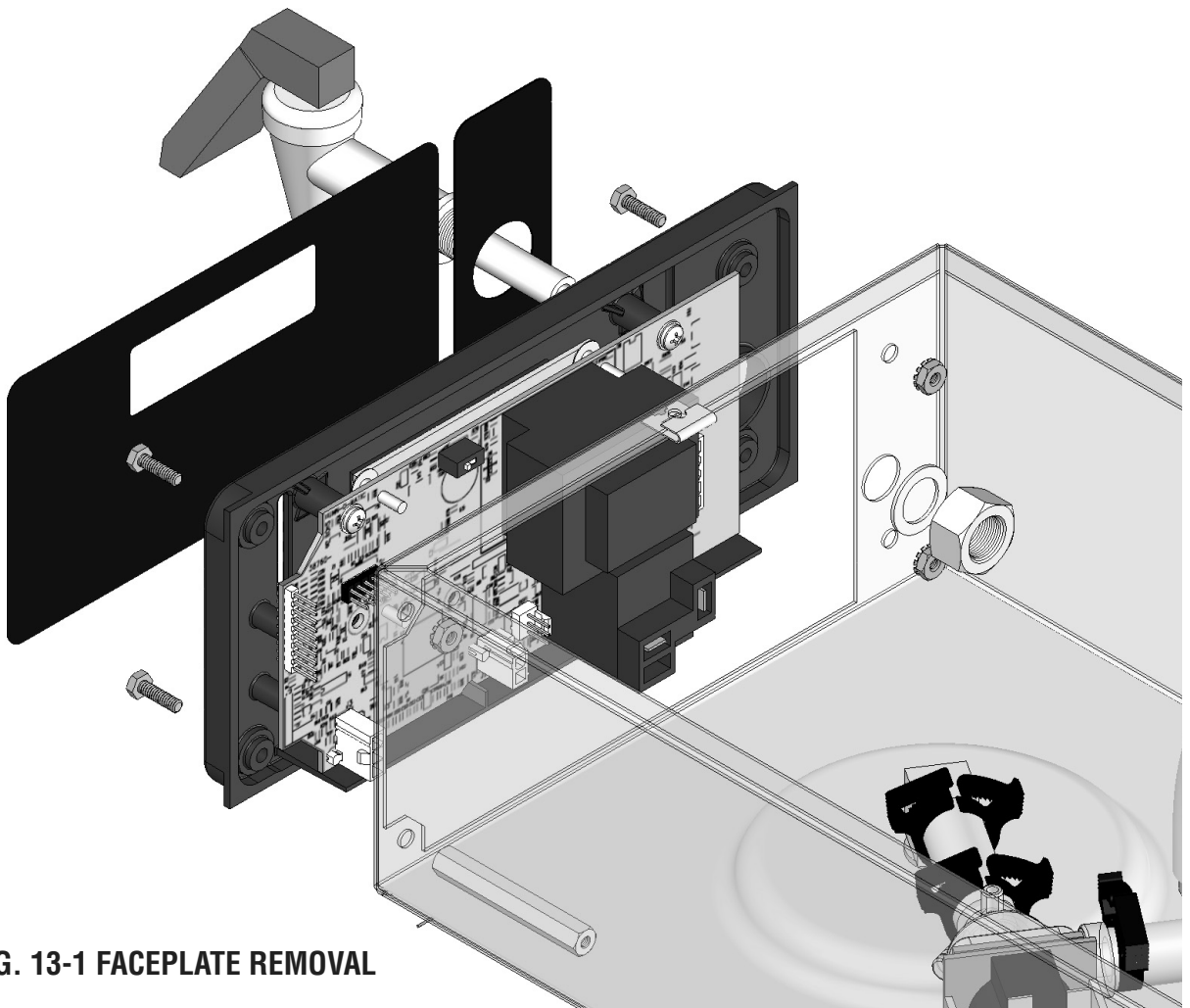

FIG. 13-1 FACEPLATE REMOVAL

MEMBRANE SWITCH

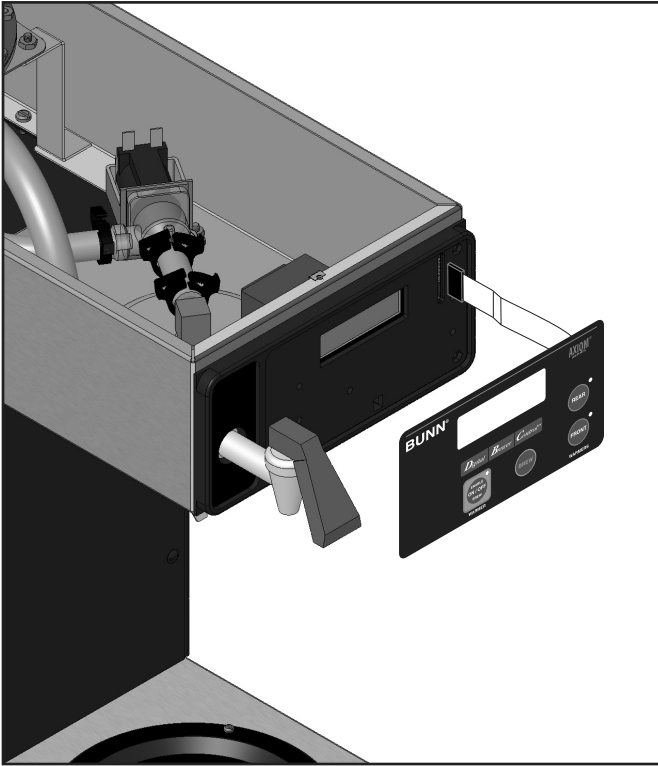

FIG. 14-1 MEMBRANE SWITCH

Location:

The Membrane Switch is located on the front face plate.

Test Procedures:

There are two methods for testing the membrane switch. The easiest method is to use the built in test mode. Refer to the Programming Section for Service Tools/Test Switches. If for some reason you can't get into the program modes, or brewer won't power up,

you can test it with an ohmmeter or continuity tester. Refer to the schematic to trace the appropriate pins.

NOTE: Pin 1 is the static shield & will not provide a reading to the other pins. There are two commons in this circuit, pins 9 & 10.

Disconnect brewer from power source before disconnecting ribbon cable from control board.

Removal and Replacement:

1. Disconnect the ribbon cable from 10-pin connector on the control board.
2. Gently peel the membrane switch from the front face plate assembly.
4. Remove any adhesive that remains on the front face plate.
5. Remove the adhesive backing from the new membrane switch. Insert the ribbon cable through the slot in the front face plate and apply the membrane switch to the front face plate.
6. Connect the ribbon cable to the 10-pin connector on the control board making sure every pin on the control board is inserted into the ribbon cable connector.



Wrap a thin paper clip around each meter lead and extend past the tip by 1/4" - 1/2". You may need to sand off the clear coating on some clips!

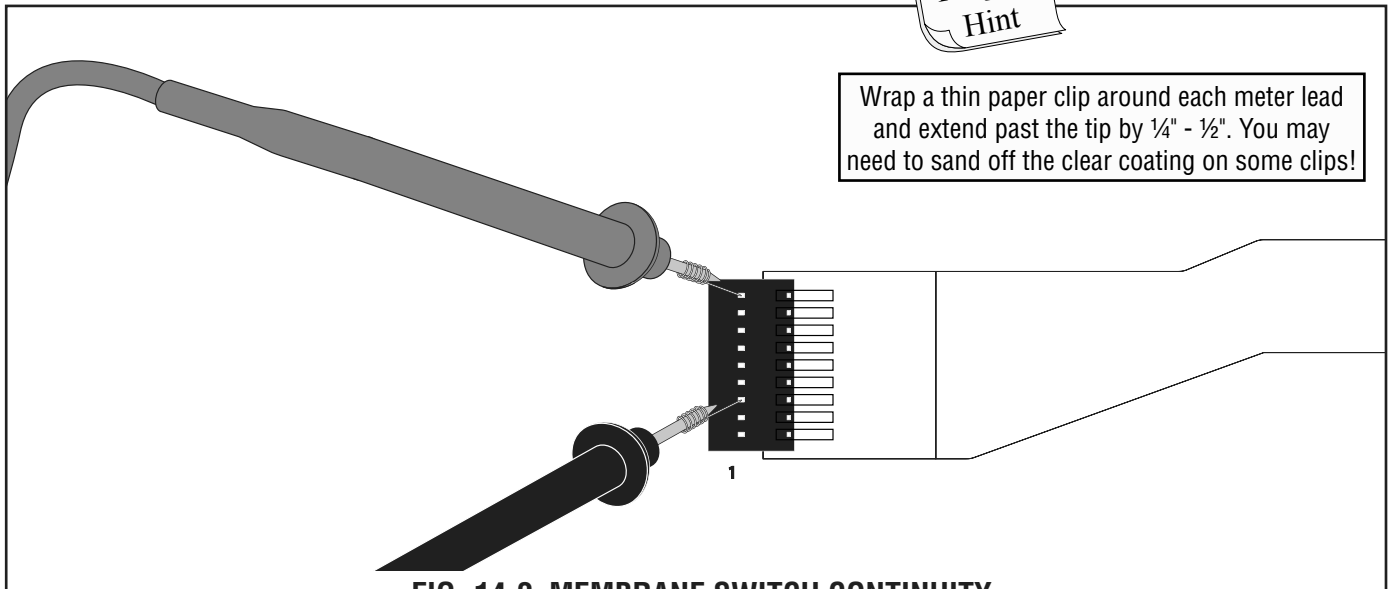

FIG. 14-2 MEMBRANE SWITCH CONTINUITY

BREW VALVE

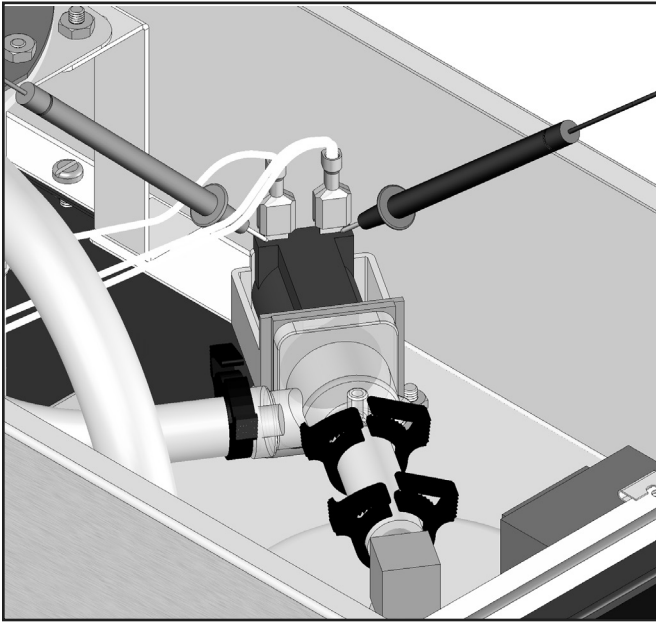

FIG. 15-1 BREW VALVE

Location:

The brew valve is located inside the top cover behind the front face plate.

Test Procedures:

1. Refer to the Programming Section for Service Tools/ Test Outputs/Brew Valve.
2. Be sure brew funnel & server are in place before activating valve.
3. Check the valve for coil action. Turn on the valve with the test mode. Listen carefully in the vicinity of the brew valve for a click as the coil pulls the plunger in.

If no sound is heard as described, proceed to #4.

If the sound is heard as described, there may be a blockage in the valve, hose, tank, or sprayhead. Disconnect the brewer from the power source. Remove the valve and inspect for blockage, and de-lime all related areas.

4. Connect the voltmeter leads to the coil terminals. Turn on the valve with the test mode.

NOTE: Due to the internally rectified coil, the indication will be 120VAC potential all the time.

Option 1: The actual a/c volt reading will slightly increase or go higher than the potential reading when you turn on or activate the brew valve.

Option 2: Install an amp clamp around one dispense valve wire and measure the flow of current through the valve when activated. The reading or specification

must be within 0.08 to 0.20 amps.

If voltage is present as described, but no coil action is observed, brew valve is defective. Replace valve and test again to verify repair.

If voltage or current is not present as described, refer to Wiring Diagrams and Triac Map for wiring harness or control board output (triac) issue.

Removal and Replacement:

1. Disconnect the brewer from the power source.
2. Disconnect wires from the valve.
3. Drain enough water from the tank so the water level is below the outlet.
4. Remove hoses from the valve.
5. Remove the two #8-32 nuts securing the valve to the sprayhead panel.
6. Install new valve using the two #8-32 nuts.
7. Reconnect hoses to the valve and secure in place with clamps.

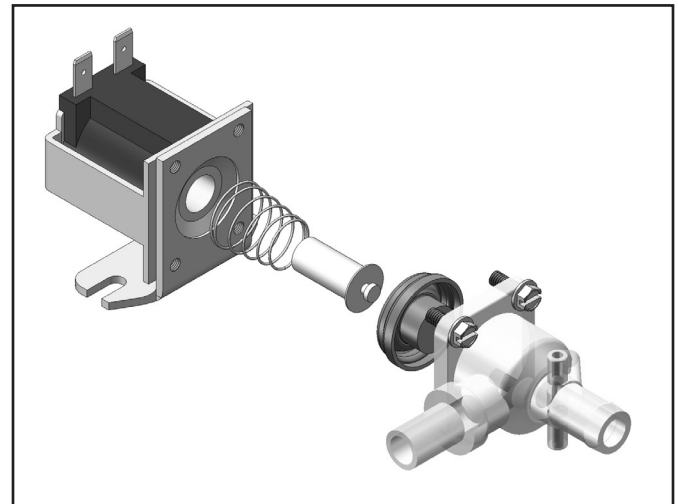

FIG. 15-2 BREW VALVE



Due to the internally rectified coil, do not attempt to test this type of coil with an ohmmeter. The reading will be open or very high resistance, depending on the polarity of your meter leads.

OPTIONAL BREW VALVE (ON SELECT MODELS)

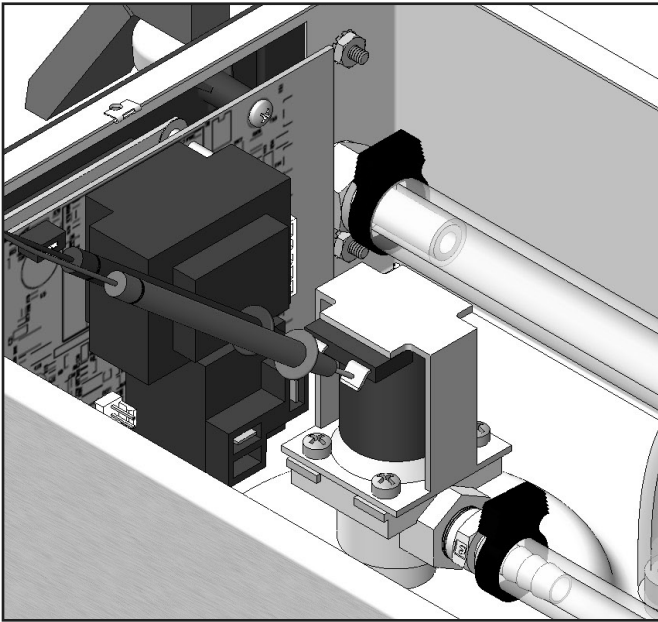

FIG. 16-1 OPTIONAL BREW VALVE

Location:

The brew valve is located inside the top cover behind the front face plate.

Test Procedures:

1. Refer to the Programming Section for Service Tools/ Test Outputs/Brew Valve.
2. Be sure brew funnel & server are in place before activating valve.
3. Check the valve for coil action. Turn on the valve with the test mode. Listen carefully in the vicinity of the brew valve for a click as the coil pulls the plunger in.

If no sound is heard as described, proceed to #4.

If the sound is heard as described, there may be a blockage in the valve, hose, tank, or sprayhead. Disconnect the brewer from the power source. Remove the valve and inspect for blockage, and de-lime all related areas.

4. Connect the voltmeter leads to the coil terminals. Turn on the valve with the test mode.

NOTE: Due to the internally rectified coil, the indication will be 120VAC potential all the time.

Option 1: The actual a/c volt reading will slightly increase or go higher than the potential reading when you turn on or activate the brew valve.

Option 2: Install an amp clamp around one dispense valve wire and measure the flow of current through the valve when activated. The reading or specification

must be within 0.08 to 0.20 amps.

If voltage is present as described, but no coil action is observed, brew valve is defective. Replace valve and test again to verify repair.

If voltage or current is not present as described, refer to Wiring Diagrams and Triac Map for wiring harness or control board output (triac) issue.

Removal and Replacement:

1. Disconnect the brewer from the power source.
2. Disconnect wires from the valve.
3. Drain enough water from the tank so the water level is below the outlet.
4. Remove sprayhead and hose from the valve.
5. Remove the nut securing the valve to the sprayhead panel.
6. Install new valve using the nut from step 5.
7. Reinstall sprayhead and hose to the valve and secure in place with clamps.

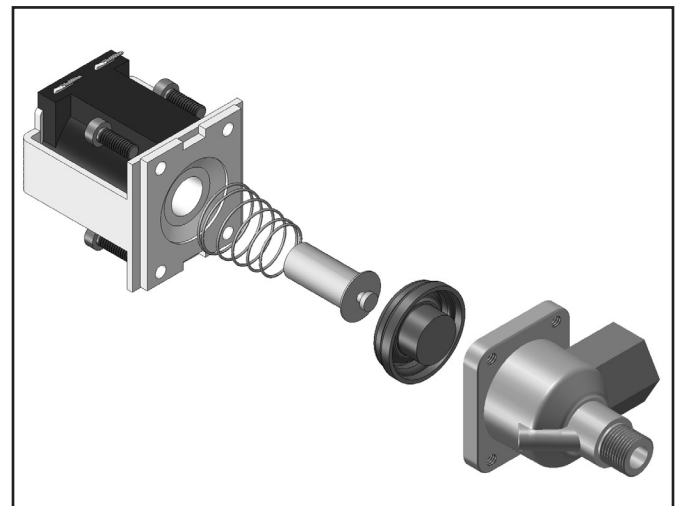

FIG. 16-2 OPTIONAL BREW VALVE



Due to the internally rectified coil, do not attempt to test this type of coil with an ohmmeter. The reading will be open or very high resistance, depending on the polarity of your meter leads.

LEVEL PROBE SYSTEM

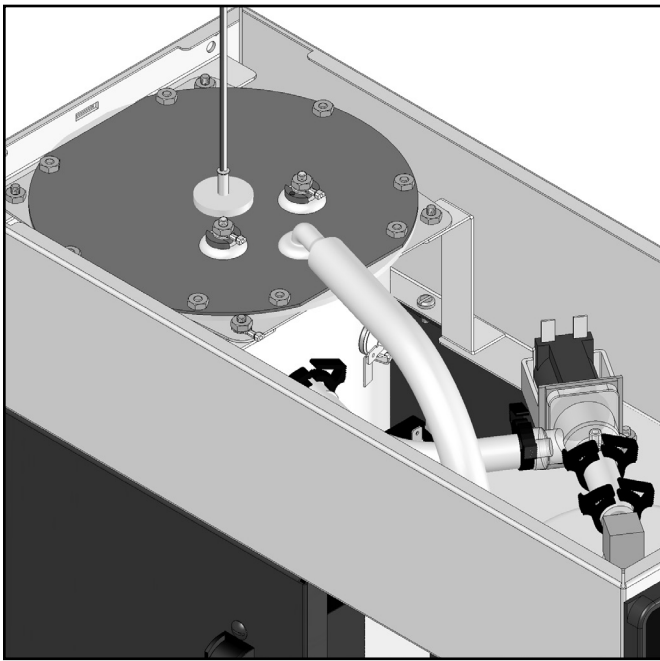

FIG. 17-1 LEVEL PROBES

Location:

The level probes are located inside the tank lid.

Operation:

The level probes sense the water level in the tank by the conductive minerals in the water grounding out the very low AC voltage applied to the probes. The circuit monitors the time it takes the water to drop the distance from the short probe to the long probe. Proper "initial set up", and keeping mineral build up off the probes/grommets, is required for this system to operate properly. A brew abort feature is "built in". In the event that the drop in water level from the short probe to the long probe takes too long, the brew cycle will abort and return to the main screen. This could be caused by: Mineral build up on probes/grommets (very hard water); probes shorting to top cover (verify the mylar shield(s) are installed; plugged outlet (ie: sprayhead limed up); incorrect operator use with the pour over model (ie: pour in water and pressing "start" button)

Test Procedures:

1. Enter programming level 2, scroll to "Refill". **NOTE:** This screen only reads the long probe (blue wire) and is used for setting the refill conductance threshold.

Alternate: Scroll to "Service Tools".

Then scroll to "LP1 & LP2". LP1 = short probe, LP2 = long probe.

2. A high reading (approximately 255) indicates water is not touching, or not conductive enough to ground the circuit. A low reading (0-2) indicates the probe is grounded.

Removal and Replacement:

1. Disconnect the brewer from the power source and allow tank to cool.
2. Remove nut, wire, and washers from probe.
3. Pull probe straight up from grommet.
4. When reinstalling, ensure long probe is connected to the blue wire, and short probe is connected to the brown wire.

NOTE: Heavy mineral build up on probes could indicate that the tank, lid, and grommets may need to be delimed as well.

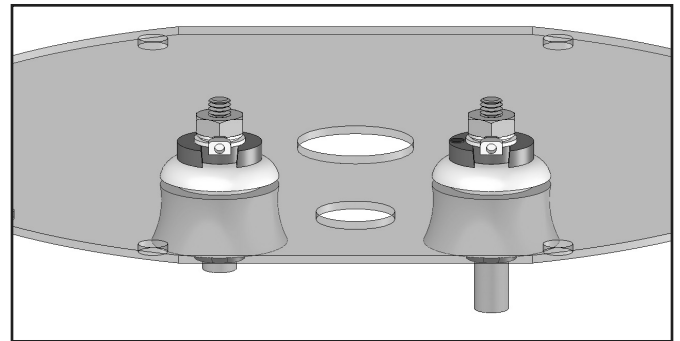

FIG. 17-2 LEVEL PROBES

REFILL VALVE - EARLY MODELS

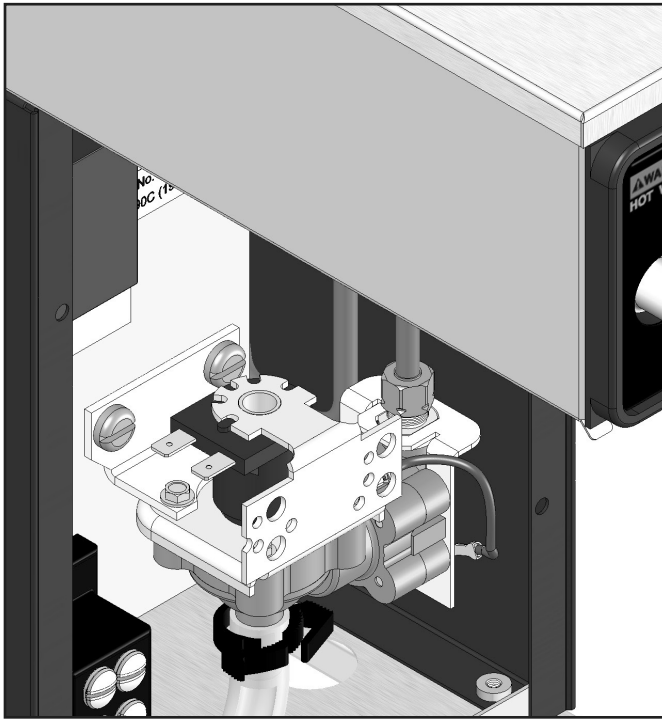

FIG. 18-1 REFILL VALVE

Location:

The refill valve is located inside the front of the brewer.

Test Procedures:

1. Enter programming level 2, scroll to "Service Tools" then scroll to "Refill Valve".
2. *Briefly* activate the refill valve in the test mode. With a voltmeter, check the voltage across the coil wires.
3. The indication must be 120 volts ac for two wire 120 volt models and three wire 120/208 -240 volt models or 230 volts ac for two wire 230 volt models.

If voltage is present, proceed to # 4.

If voltage is not present, refer to Wiring Diagrams and check main wiring harness. If harness checks ok, replace control board.

4. Check the refill valve for coil action. *Briefly* activate the refill valve in the test mode and listen carefully near the refill valve for a "clicking" sound as the magnetic coil pulls the plunger in.

If the sound is heard as described and water will not pass through the refill valve, there may be a blockage in the water line before the refill valve or, the solenoid valve may require inspection for wear, and removal of waterborne particles.

If the sound is not heard as described, proceed to # 5.

5. Disconnect the brewer from the power source.
6. Check for continuity across the refill valve coil terminals.

If continuity is not present as described, replace the refill valve.

If continuity is present as described, there could be some debris in the valve.

Removal and Replacement:

1. Remove both wires from the refill valve.
2. Verify that the white shutoff clamp between valve and tank is squeezed shut.
3. Disconnect both water lines at the valve.
4. Remove the two 1/4"-20 screws securing the valve to the component mounting bracket.
5. Using the two 1/4"-20 screws, install the new valve to the component mounting bracket.
6. Securely fasten the water lines to the valve.
7. Refer to wiring diagrams when reconnecting the wires.
8. Install access panels and covers and refer to Initial Set-up for refill and operation.

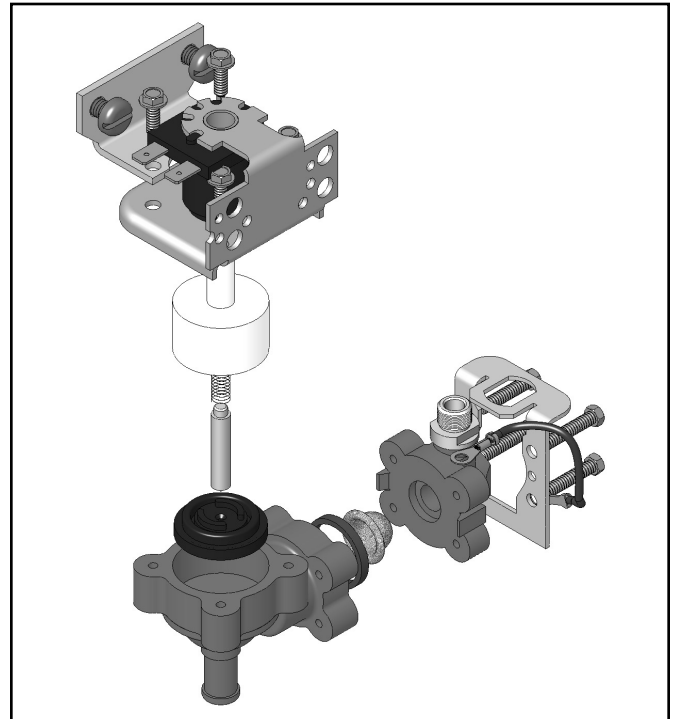

FIG. 18-2 REFILL VALVE

REFILL VALVE - LATER MODELS

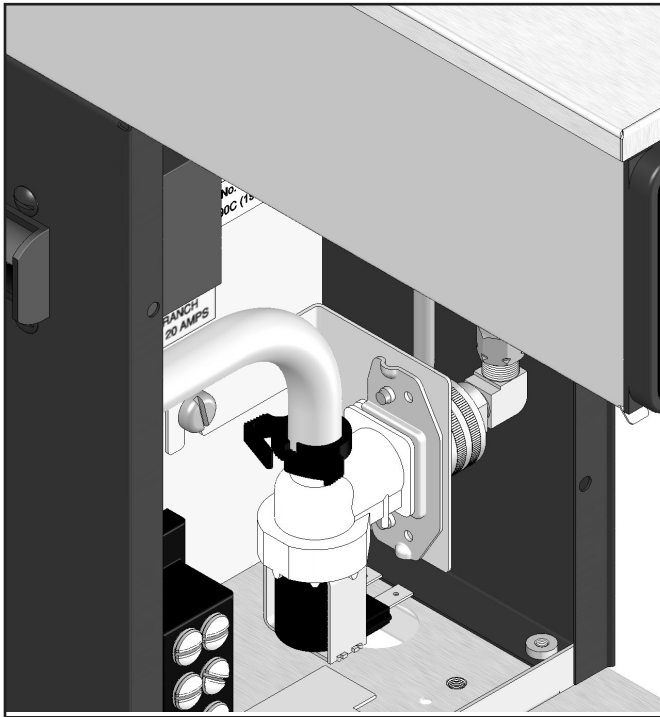

FIG. 19-1 LATER REFILL VALVE

Location:

The refill valve is located inside the front of the brewer.

Test Procedures:

1. Enter programming level 2, scroll to "Service Tools" then scroll to "Refill Valve".
2. *Briefly* activate the refill valve in the test mode. With a voltmeter, check the voltage across the coil wires.
3. The indication must be 120 volts ac for two wire 120 volt models and three wire 120/208 -240 volt models or 230 volts ac for two wire 230 volt models.

If voltage is present, proceed to # 4.

If voltage is not present, refer to Wiring Diagrams and check main wiring harness. If harness checks ok, replace control board.

4. Check the refill valve for coil action. *Briefly* activate the refill valve in the test mode and listen carefully near the refill valve for a "clicking" sound as the magnetic coil pulls the plunger in.

If the sound is heard as described and water will not pass through the refill valve, there may be a blockage in the water line before the refill valve or, the solenoid valve may require inspection for wear, and removal of waterborne particles.

If the sound is not heard as described, proceed to

5.

5. Disconnect the brewer from the power source.
6. Check for continuity across the refill valve coil terminals.

If continuity is not present as described, replace the refill valve.

If continuity is present as described, there could be some debris in the valve.

Removal and Replacement:

1. Remove both wires from the refill valve.
2. Verify that the white shutoff clamp between valve and tank is squeezed shut.
3. Disconnect both water lines at the valve.
4. Remove the two 1/4"-20 screws securing the valve to the component mounting bracket.
5. Using the two 1/4"-20 screws, install the new valve to the component mounting bracket.
6. Securely fasten the water lines to the valve.
7. Refer to wiring diagrams when reconnecting the wires.
8. Install access panels and covers and refer to Initial Set-up for refill and operation.

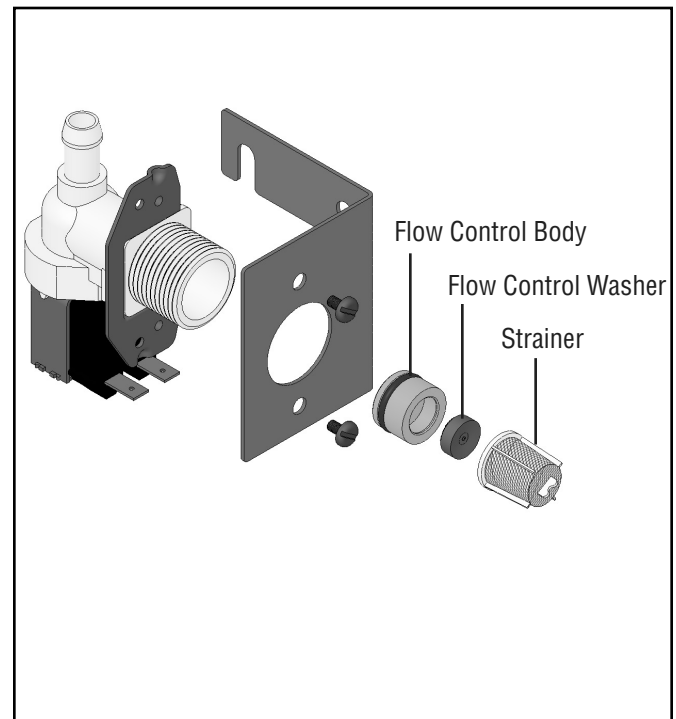

FIG. 19-2 LATER REFILL VALVE

TANK HEATERS

Location:

The tank heaters are located inside the tank and secured to the tank bottom.

Test Procedures:

1. With a voltmeter, check voltage across the white wire (120V Models) or red wire (120/208-240V Models) from the terminal block and black wire from the control board. Connect brewer to the power source. The indication must be 120 volts ac for two wire 120 volt models or 208-240 volts ac for three wire 120/208-240 volt models (during a heating cycle).
2. Disconnect the brewer from the power source.

If voltage is present as described, proceed to #3.

If voltage is not present as described, refer to the Wiring Diagrams and check wiring harness. If harness checks ok, replace control board.

3. Disconnect the wires from the tank heater terminals.
4. Check resistance value across tank heater terminals and compare to chart.

If resistance is present as described, reconnect the wires, the tank heater is ok.

If resistance is not present as described, replace the tank heater.

NOTE- If any resistance is read between sheath and either terminal, remove and inspect heater for cracks in the sheath.

HEATER	RESISTANCE
1425W-120V	10.10 Ω
3500W-240V	16.46 Ω
1850W-240V	31.14 Ω
3500W-200V	11.43 Ω
3000W-240V	19.20 Ω
2268W-240V	6.35 Ω
TERMINAL TO SHEATH - INFINITE (OPEN)	

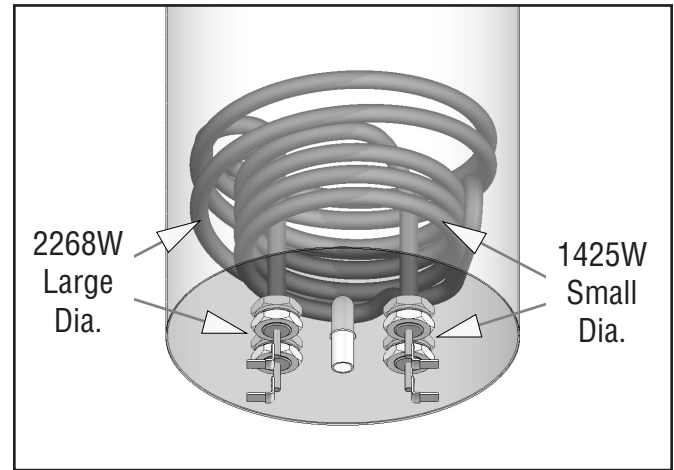

FIG. 20-1 DV TANK HEATERS

Removal and Replacement:

1. Remove the top cover or top warmer housing and front access panel as previously described.
2. Drain water from the tank.
3. Disconnect all the hoses from the tank.
4. Disconnect the temperature probe from the top of the tank by pulling the probe from the grommet in the top of the tank lid.
5. Remove both level probes from their grommets.
6. Disconnect the green wire from the top of the tank.
7. Disconnect the limit thermostat from the side of the tank.
8. Disconnect the two white wires from the tank warmer blanket.
9. Disconnect the wires from tank heater terminals.
10. Remove the four #8-32 nuts securing the tank to the mounting brackets and remove the tank assembly.
11. Remove the eight #8-32 nuts securing the tank lid to the tank.
12. Remove the two hex nuts securing the tank heater to the bottom of the tank. Remove tank heater with gaskets and discard.
13. Install new tank heater(s) with gaskets to the bottom of the tank and secure with two hex nuts.
14. Install tank assembly onto mounting brackets and secure in place with four #8-32 nuts.
15. Install tank lid and secure in place with eight #8-32 nuts.
16. Connect the two white wires of the tank warmer blanket.

LIMIT THERMOSTAT

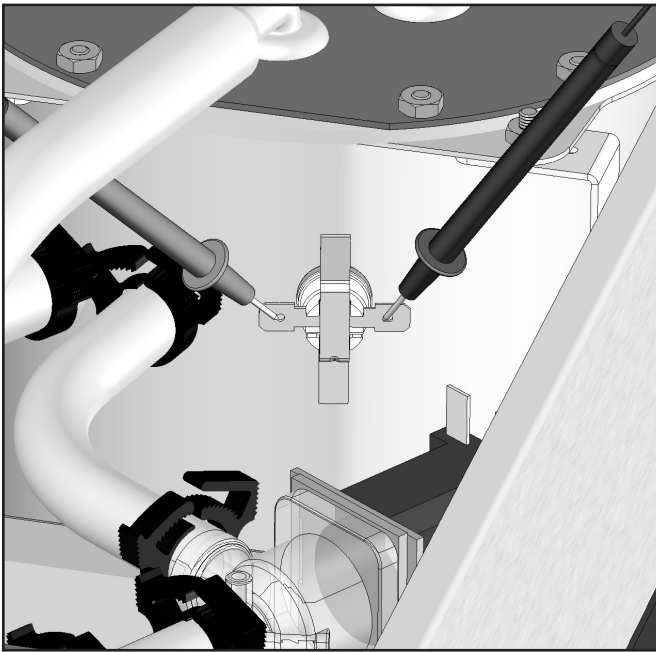

FIG. 21-2 LIMIT THERMOSTAT

Location:

The limit thermostat is located inside the top cover on the front side of the tank.

Test Procedures:

1. Disconnect the brewer from the power source.
2. Disconnect the wires from the limit thermostat.
3. With an ohmmeter, check for continuity across the limit thermostat terminals.

If continuity is present as described, the limit thermostat is operating properly.

If continuity is not present as described, replace the limit thermostat.

Removal and Replacement:

1. Remove the wires from limit thermostat terminals.
2. Carefully slide the limit thermostat out from under the retaining clip and remove limit thermostat.
3. Carefully slide the new limit thermostat into the retaining clip. Ensure the metal face has good contact with tank.

THERMAL CUT OFF (230V MODELS ONLY)

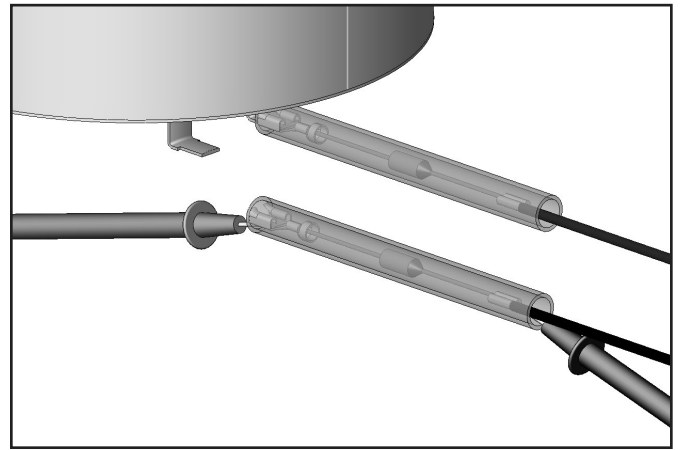

FIG. 21-1 TCO CHECK

Location:

The TCO's are located under the tank at the heater connections.

Test Procedures:

1. Disconnect the brewer from the power source.
2. Disconnect the TCO from the tank heater.
3. With an ohmmeter, check for continuity across the TCO as shown above.

If continuity is not present as described, replace the main harness.

BLANKET WARMER

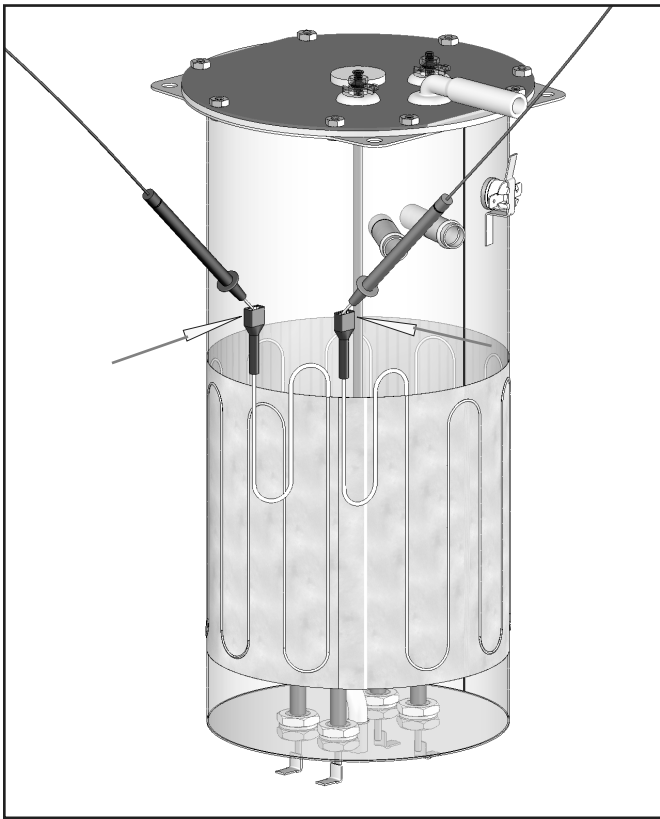

FIG. 22-1 BLANKET WARMER

Location:

The blanket warmer is wrapped around the tank assembly.

Operation:

The blanket warmer provides a low consistent heat around the tank at the point of the temperature sensor. This additional heat aids the heater circuit by reducing the number of on/off cycles, thereby extending the life of the relay contacts and the heater.

Test Procedures:

1. Disconnect the brewer from the power source.
2. With a voltmeter, check voltage across the two wires at the warmer element with the "ON/OFF" switch in the "ON" position. Connect the brewer to the power source. The indication must be 120 volts ac for two wire 120 volt models and three wire 120/208 and 120/240 volt models, or 230 volts ac for two wire 230 volt models.
3. Disconnect the brewer from the power source.

If voltage is present as described, proceed to #4.
If voltage is not present as described, refer to Wiring Diagrams and check wiring harness.

4. Check the resistance across the two terminals on the blanket warmer. Refer to chart below.

If resistance is to specification, reconnect the two wires to the blanket warmer.

If resistance is not to specification, replace the blanket warmer.

Removal and Replacement:

1. Disconnect the blanket warmer wire from the piggyback terminal on the refill valve.
2. Remove the tank assembly from the brewer.
3. Peel old blanket warmer off tank.
4. Install new blanket warmer on tank with bottom of blanket 1½" from bottom of tank.
5. Connect one of the white wires to the piggyback terminal on the limit thermostat.
6. Reinstall tank assembly.
7. Connect the other white wire to the piggyback terminal on the refill valve.

WARMER	RESISTANCE
50W-120V	288.0 Ω
50W-220V	968.0 Ω

TEMPERATURE PROBE

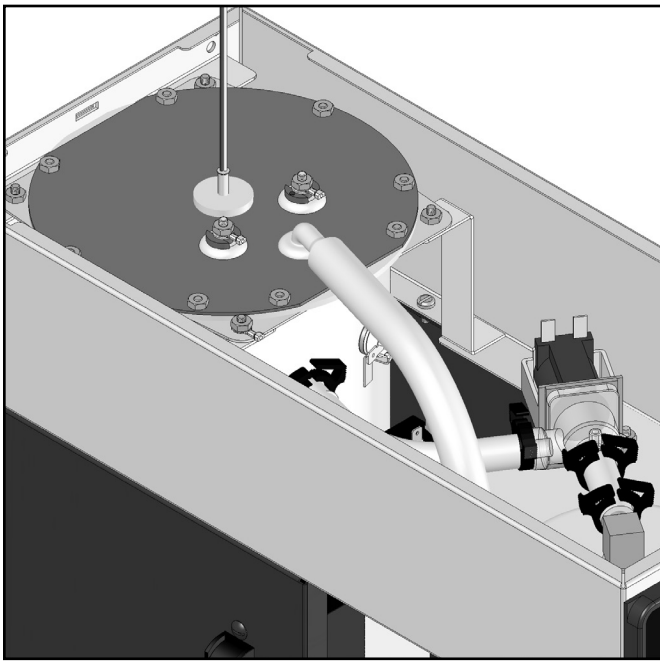

FIG. 23-1 TEMPERATURE PROBE

Location:

The temperature probe is inserted through the tank lid assembly.

Test Procedures:

1. Disconnect the brewer from the power source.
2. With a DC voltmeter, check voltage across the two wires at J9 on control board (Black probe to black wire, red probe to white wire. Refer to FIG 18-2). Connect the brewer to the power source. The indication should be *approximately* between 4vdc cool to 1vdc at ready temperature.
3. Disconnect the brewer from the power source.

If voltage is present as described, circuit is working correctly, check limit thermostat (and TCO on 230V models).

If voltage is not present as described, proceed to #4.

4. Disconnect temperature probe from J9 on control board. Check the resistance across the two terminals of the temperature probe. The indication should be *approximately* between 10.5K Ω cool to 870 Ω at ready temperature.

If resistance is to specification, replace the control board.

If resistance is not to specification, replace the temperature probe.

Removal and Replacement:

1. Disconnect the brewer from the power source.
2. Disconnect the two pin connector from J9 on control board.
3. Pull temperature probe out of it's grommet.
4. Install in reverse order.

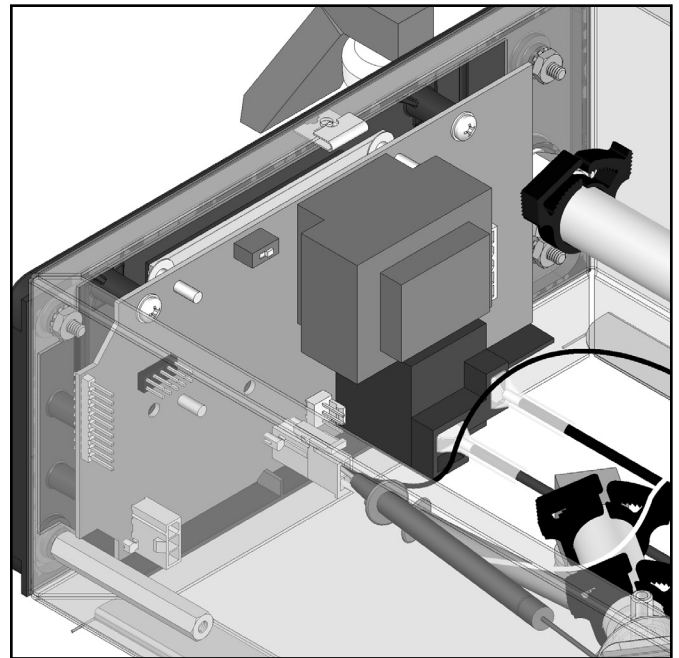

FIG. 23-2 TESTING TEMPERATURE PROBE

WARMER ELEMENTS

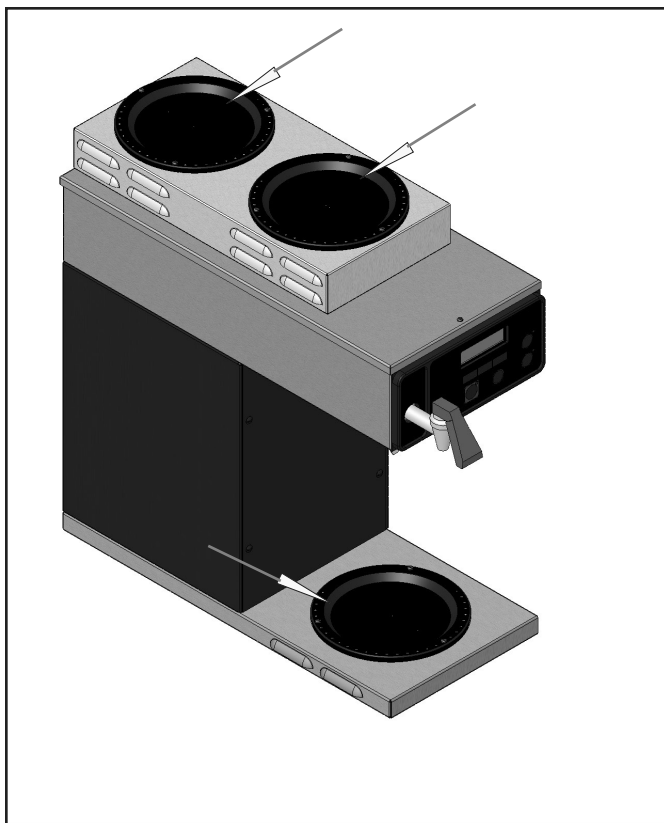

FIG. 24-1 WARMER ELEMENTS

Location:

The warmer element(s) is located under the warmer plate.

Test Procedures:

1. Disconnect the brewer from the power source.
2. With a voltmeter, check voltage across the two wires at the warmer element with the "ON/OFF" switch in the "ON" position. Connect the brewer to the power source. The indication must be 120 volts ac for two wire 120 volt models and three wire 120/208 and 120/240 volt models, or 230 volts ac for two wire 230 volt models.
3. Disconnect the brewer from the power source.

If voltage is present as described, proceed to #4.
If voltage is not present as described, refer to Wiring Diagrams and check wiring harness.

4. Check the resistance across the two terminals on the warmer element. Refer to chart below.

If resistance is to specification, reconnect the two

wires to the warmer element.

If resistance is not to specification, replace the warmer element.

Removal and Replacement:

1. Remove the three #4-40 screws securing the warmer assembly to the brewer.
2. Lift the warmer assembly from the brewer.
3. Disconnect the two wires from the warmer element terminals.
4. Remove the two #8-32 nuts securing the warmer element to the warmer plate.
5. Securely install new warmer element.
6. Reconnect the two wires to warmer element terminals.
7. Securely install warmer assembly on the brewer.



FIG. 24-2 WARMER ELEMENTS

WARMER	RESISTANCE
100W-120V	144.0 Ω
100W-220V	484.0 Ω
100W-200V	400.0 Ω
TERMINAL TO SHEATH - INFINITE (OPEN)	

VOLTAGE SELECTOR SWITCH

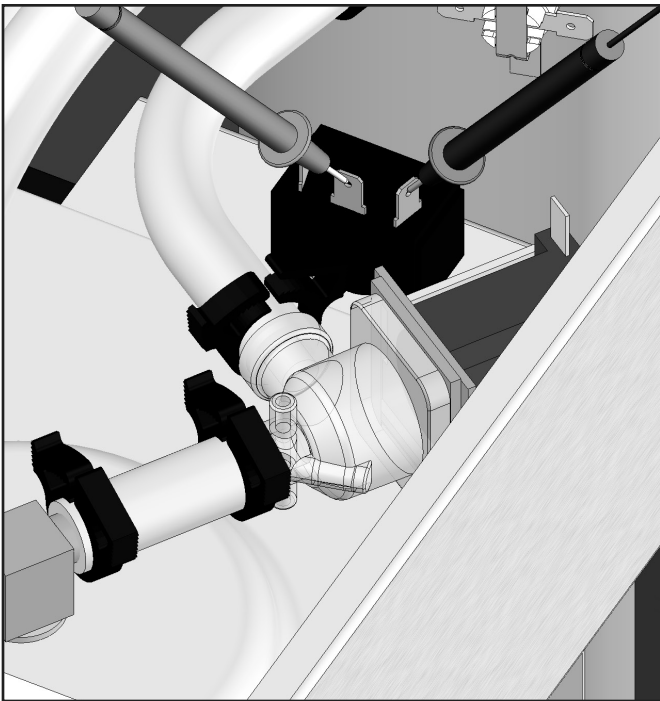

FIG. 25-1 VOLTAGE SELECTOR SWITCH

Location:

The power switch is located on the component mounting bracket behind the front access panel.

Test Procedure:

1. Disconnect the brewer from the power source.
2. Disconnect the wires from the selector switch. With the selector switch in the 120V position, check for continuity between the two right terminals of the switch.
3. With the selector switch in the 120/208-240V position, check for continuity between the two left terminals.

If continuity is not present as described, replace the switch.

Removal and Replacement:

1. Disconnect the brewer from the power source.
2. Disconnect the wires from the power switch.
3. Remove the switch mounting screws from the left side of trunk.
4. Install new switch in trunk with the two 6-32 x 1/4" mounting screws.

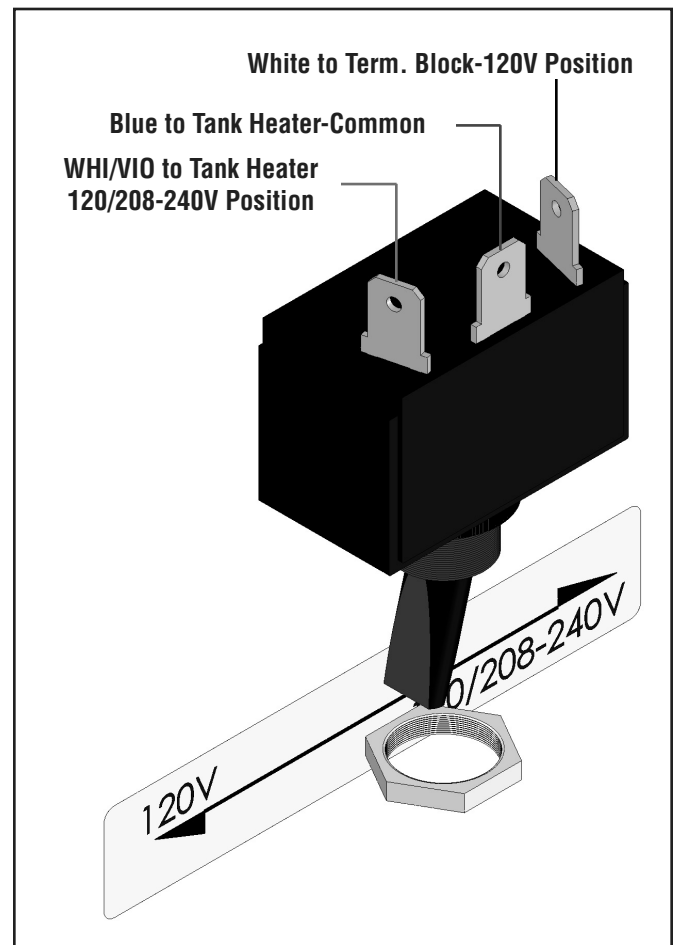

FIG. 25-2 VOLTAGE SELECTOR SWITCH TERMINALS

MASTER ON/OFF SWITCH

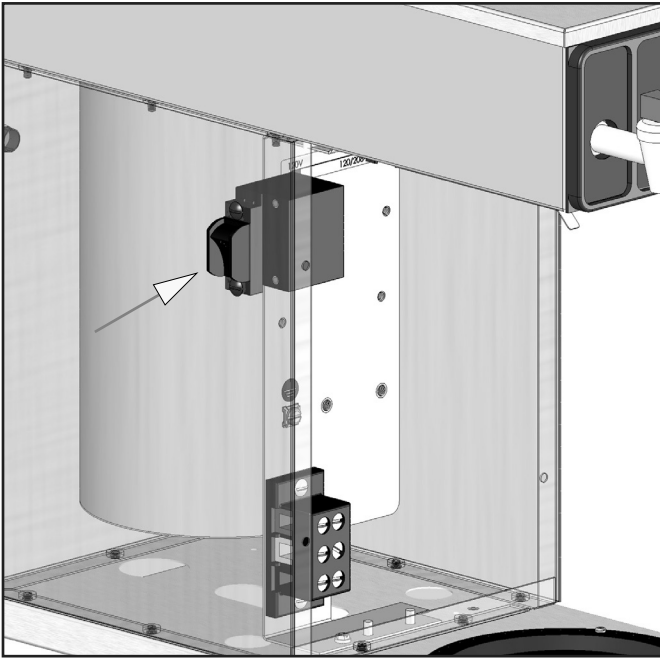

FIG. 26-1 MASTER ON/OFF SWITCH

Location:

The rocker switch is located on the left side of the trunk behind the front access panel on some earlier models. The toggle switch on later models is located on the back of the trunk.

Test Procedure:

1. Disconnect the brewer from the power source.
2. Disconnect the wires from the power switch. With the switch in the ON position, check for continuity between the upper and lower terminals on each side of the switch.

There should be continuity between the two left terminals and between the two right terminals when ON, no continuity when OFF.

If continuity is not present as described, replace the switch.

Removal and Replacement:

1. Disconnect the brewer from the power source.
2. Disconnect the wires from the power switch.
3. Remove the switch mounting screws from the left side of trunk.
4. Install new switch in trunk with the two 6-32 x 1/4" mounting screws.

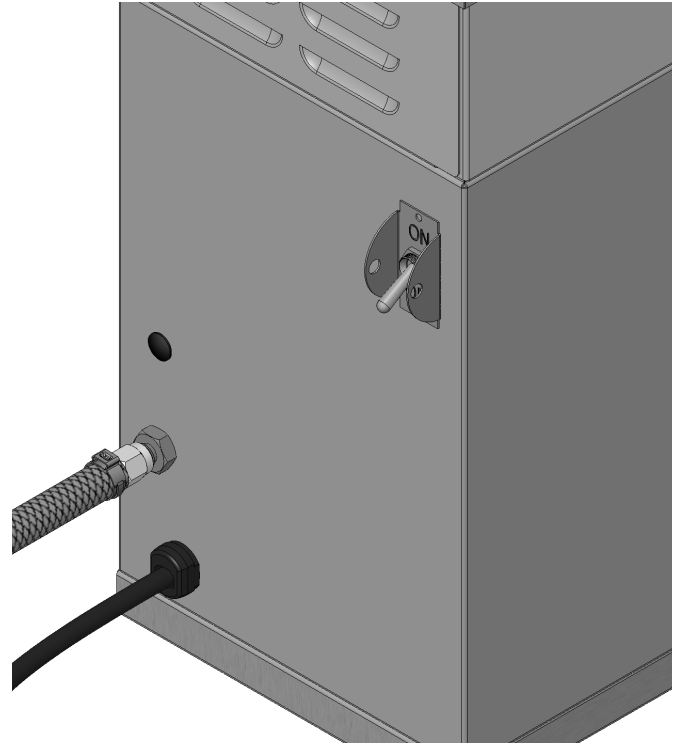

FIG. 26-2 TOGGLE SWITCH LOCATION

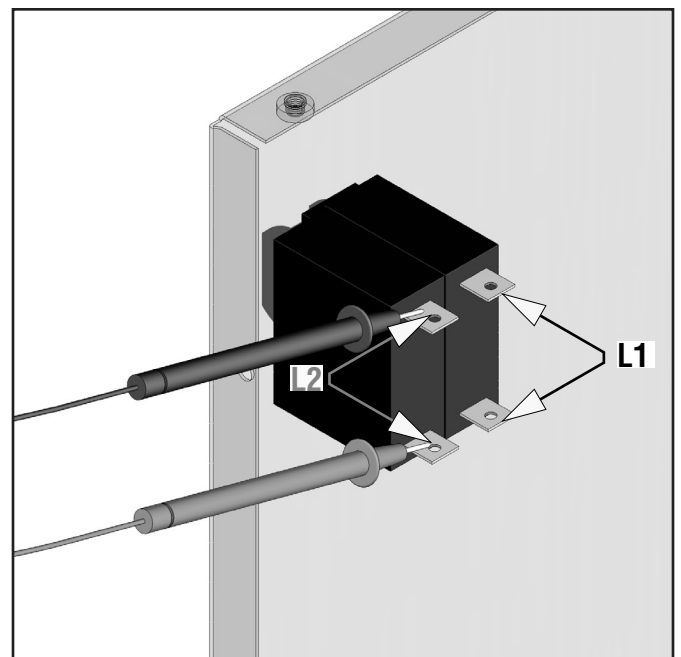
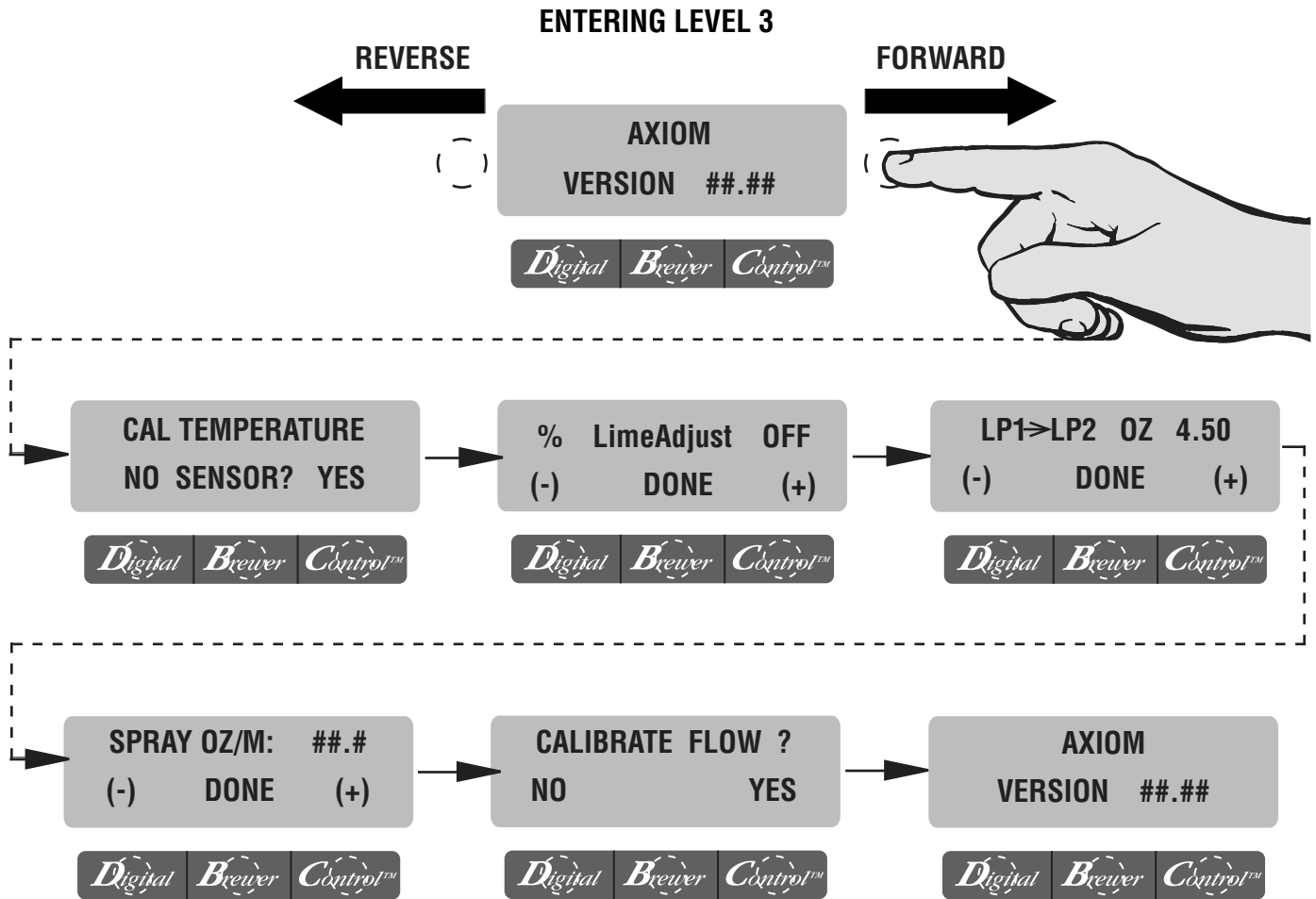

FIG. 26-3 ROCKER SWITCH

PROGRAMMING FUNCTIONS LEVEL 3 - FLOW CHART



PROGRAMMING - LEVEL 3

CAL TEMPERATURE
NO SENSOR? YES

Digital Brewer Control™

200° CAL ≥ 200°
(-) DONE (+)

Digital Brewer Control™

% LimeAdjust OFF
(-) DONE (+)

Digital Brewer Control™

LP➤ LP2 OZ 4.50
(-) DONE (+)

Digital Brewer Control™

SPRAY OZ/M: ##.#
(-) DONE (+)

Digital Brewer Control™

CALIBRATE FLOW ?
NO YES

Digital Brewer Control™

Allows technician to calibrate after probe and/or control board replacement. Select "YES".

NOTE: Tank temperature must be within range (192° - 208° F)

Insert an accurate thermometer approximately 10" into tank. Adjust the number on the right with +/- until it matches reading of thermometer. Select "DONE"

This screen allows adjustment of the lime compensation system when BrewLOGIC is turned on.

Range: 2 - 50. Default: 10% variation of brewed volume.

The remaining screens in Level 3 are just a convenient shortcut to the same ones used in previous levels.

PROGRAMMING FUNCTIONS LEVEL 4 - FLOW CHART

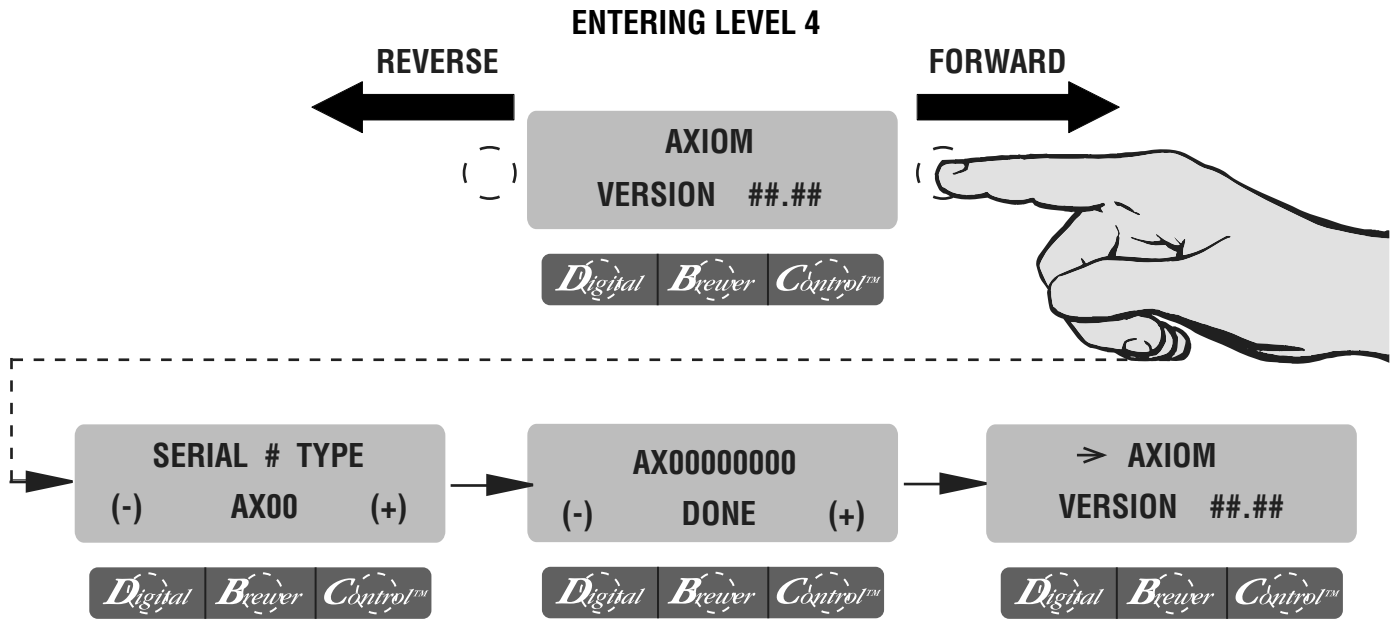

SERIAL # TYPE

(-) AX00 (+)

Digital Brewer Control™

In case of board replacement, match the Data Plate information.

- AX00** - Standard Axiom with warmers
- AXAP** - Axiom AirPot Server
- AXTN** - Not used
- AXTS** - Axiom Thermal Server
- EP00** - Engineering Prototype

AX00000000

(-) DONE (+)

Digital Brewer Control™

Scroll down (-) or up (+), to set the serial number of the machine.
NOTE: Starting from the right, each digit will control the next digit, like an odometer.

ALL MODELS EXCEPT TWINS

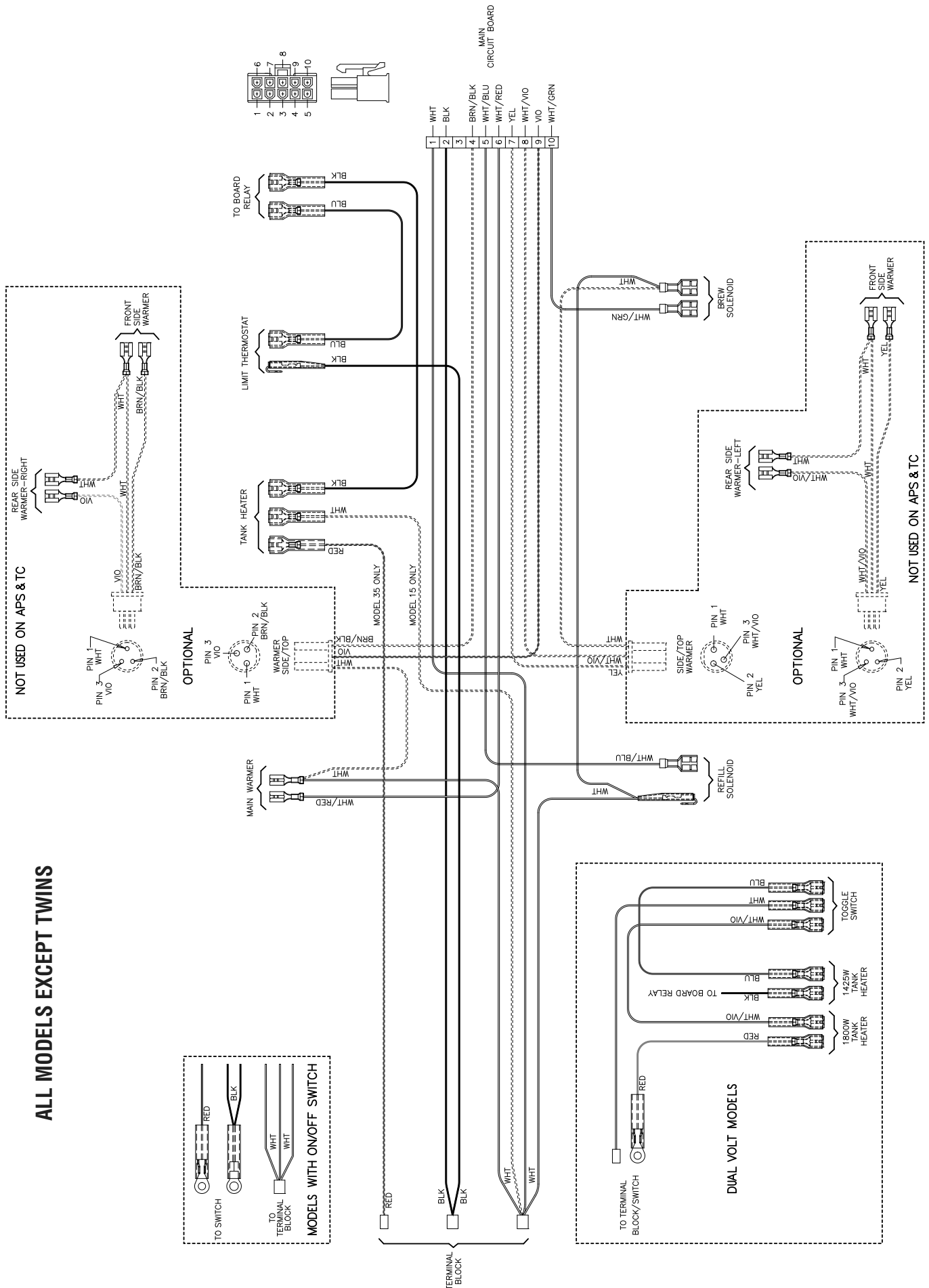

0/6 TWIN

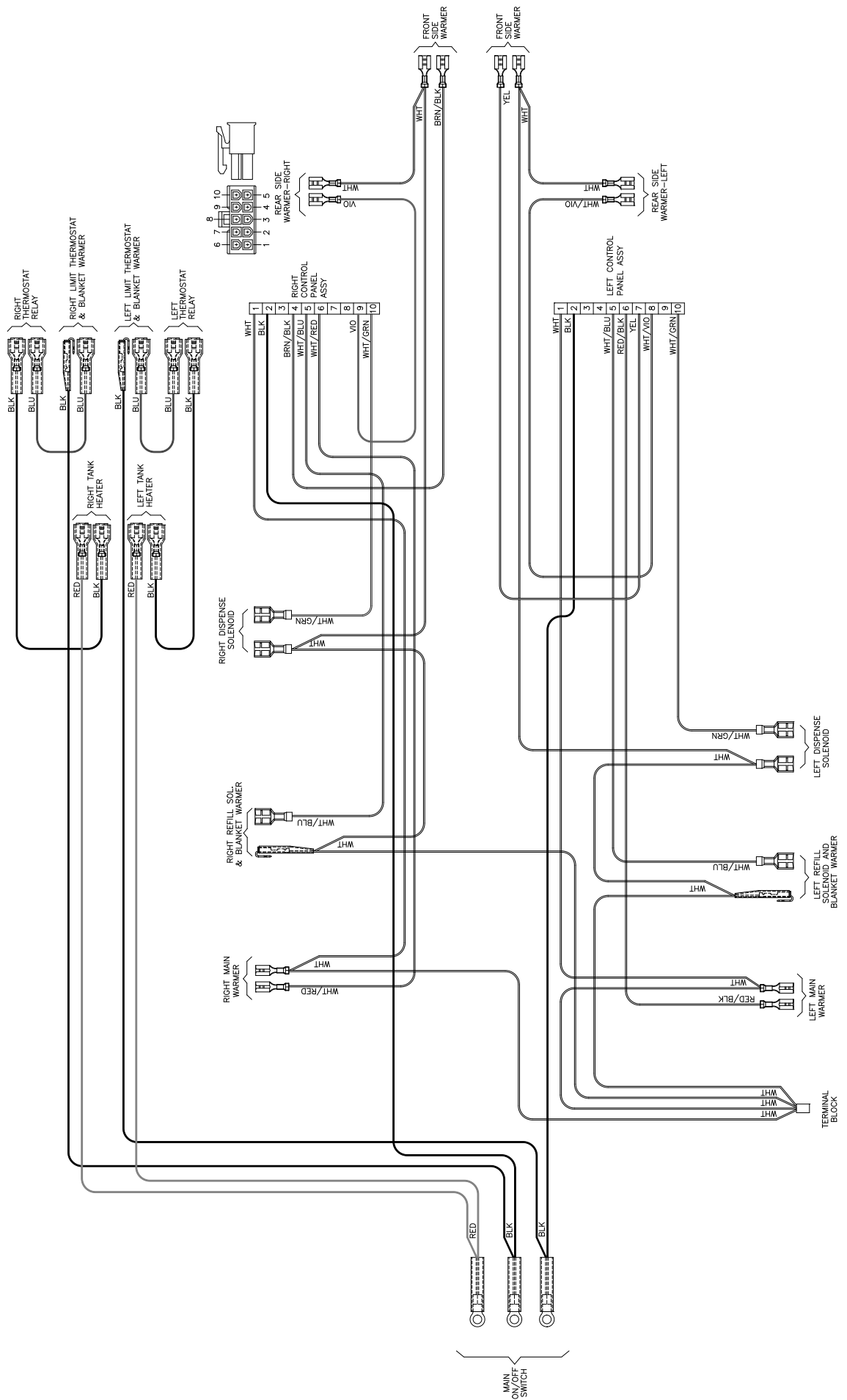

4/2 TWIN

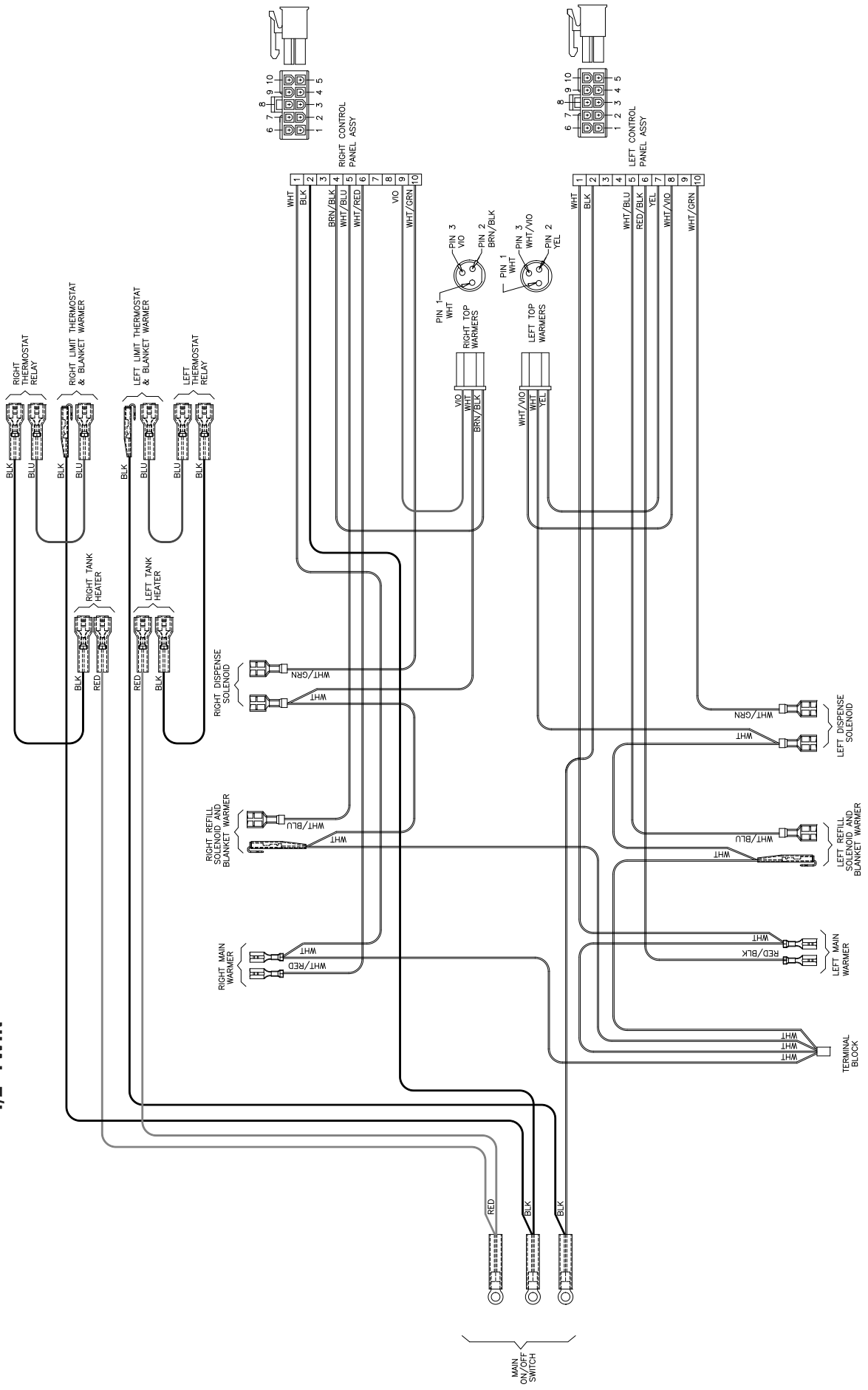

TWIN APS

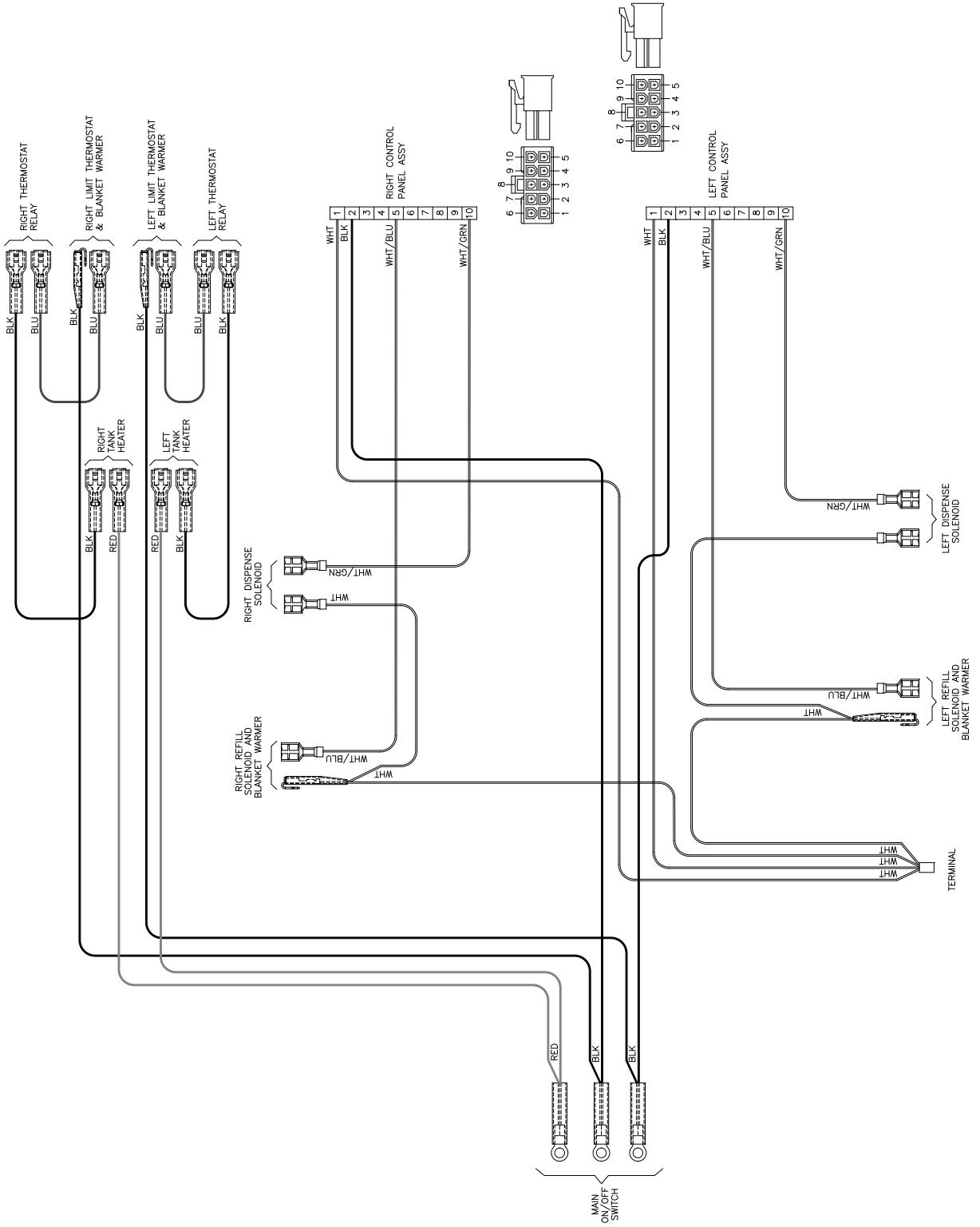

SCHEMATIC WIRING DIAGRAM AXIOM

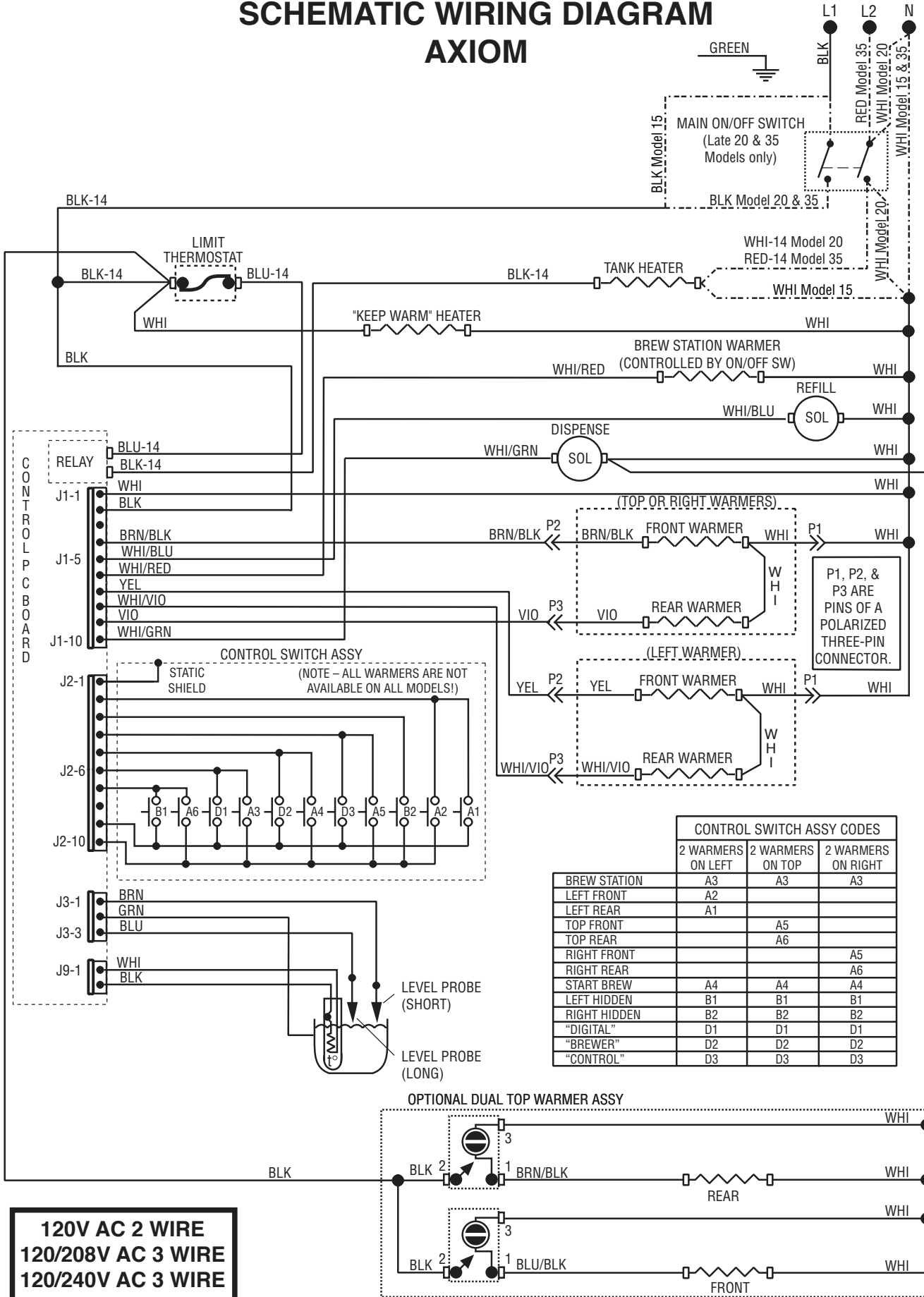

120V AC 2 WIRE
120/208V AC 3 WIRE
120/240V AC 3 WIRE
SINGLE PHASE

SCHEMATIC WIRING DIAGRAM AXIOM

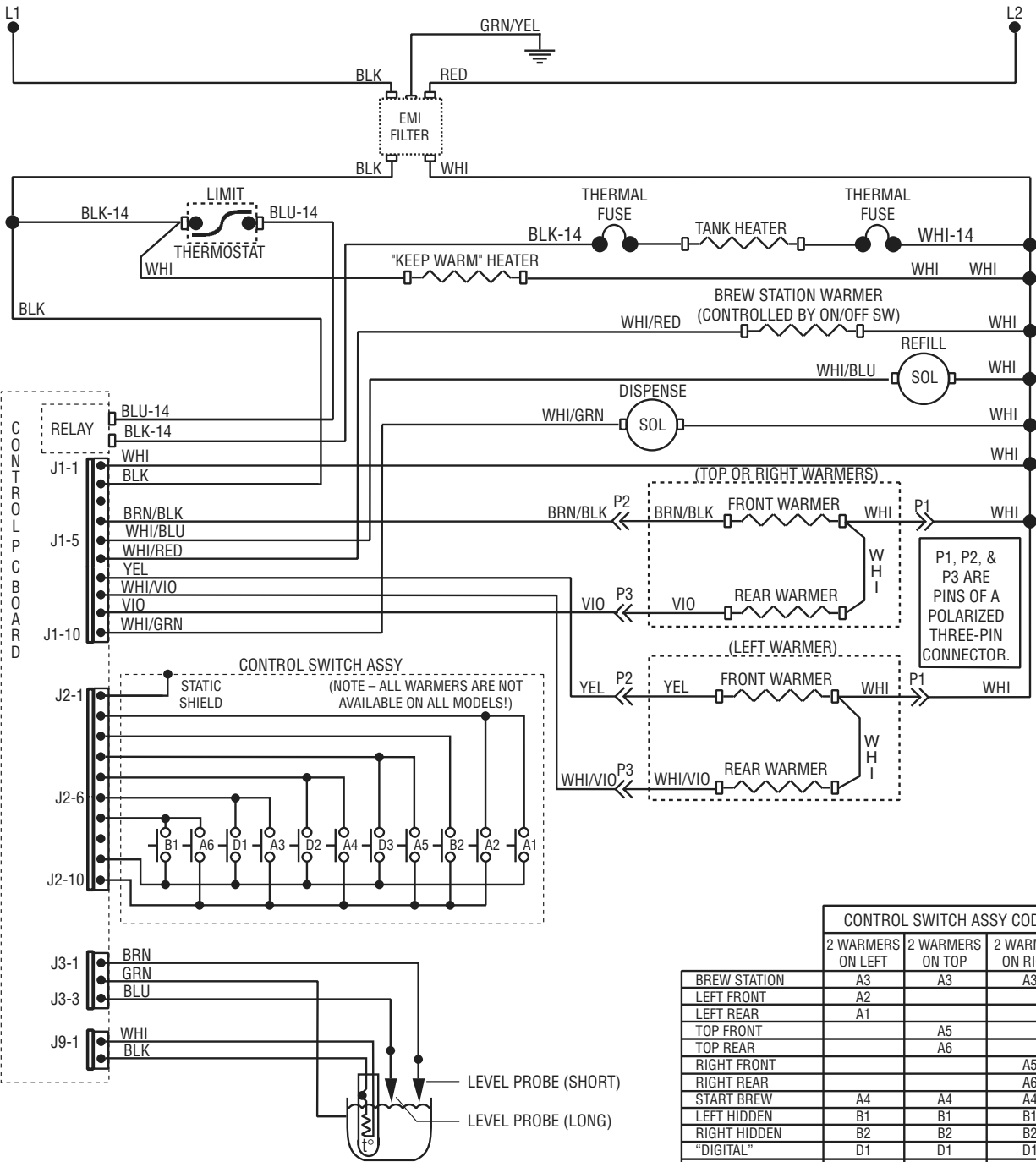

**220-240 VOLTS CE
2 WIRE + GND
SINGLE PHASE
50/60 HZ**

29077.0007C 11/13 ©2006 BUNN-O-MATIC CORPORATION

	2 WARMERS ON LEFT	2 WARMERS ON TOP	2 WARMERS ON RIGHT
BREW STATION	A3	A3	A3
LEFT FRONT	A2		
LEFT REAR	A1		
TOP FRONT		A5	
TOP REAR		A6	
RIGHT FRONT			A5
RIGHT REAR			A6
START BREW	A4	A4	A4
LEFT HIDDEN	B1	B1	B1
RIGHT HIDDEN	B2	B2	B2
"DIGITAL"	D1	D1	D1
"BREWER"	D2	D2	D2
"CONTROL"	D3	D3	D3

SCHEMATIC WIRING DIAGRAM AXIOM DV

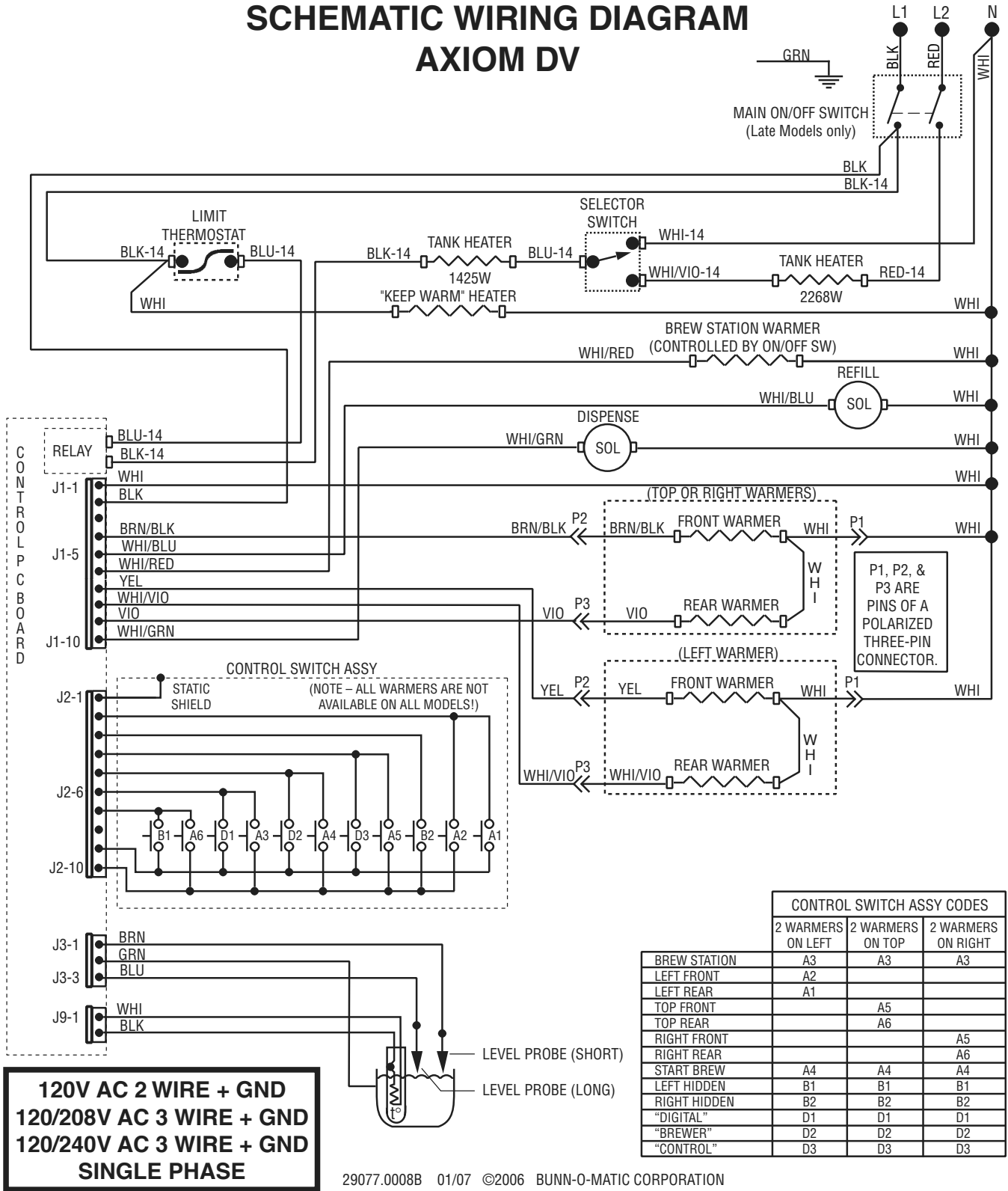

29077.0012 obsolete, refer to [29077.0022](#)

SCHEMATIC WIRING DIAGRAM AXIOM TWIN 0/6

**120/208V AC 3 WIRE + GND
120/240V AC 3 WIRE + GND
SINGLE PHASE**

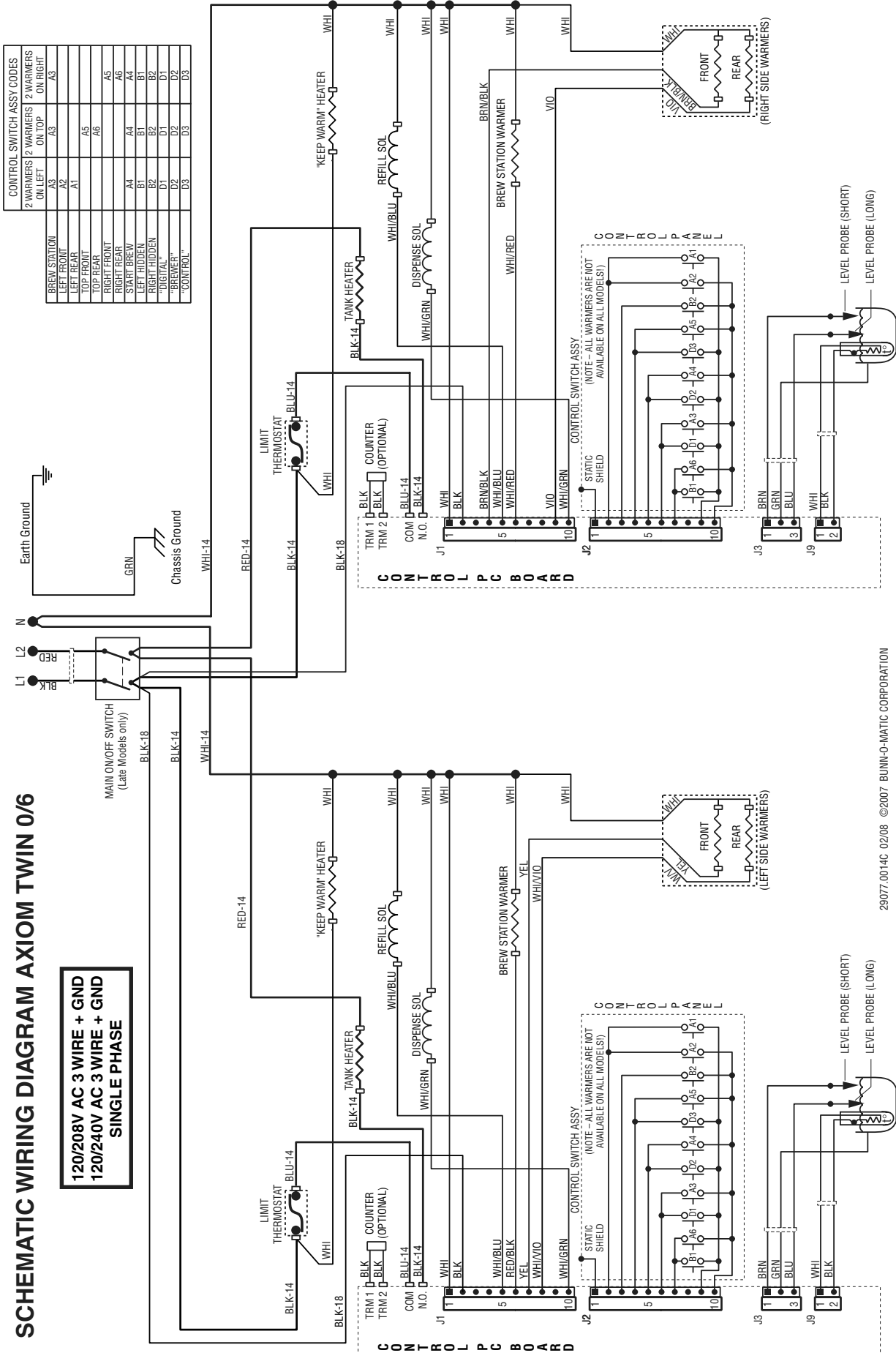

CONTROL SWITCH ASSY CODES		
2 WARMERS 2 WARMERS	ON LEFT	ON TOP
BREW STATION	A3	A3
LEFT FRONT	A2	A3
LEFT REAR	A1	A5
RIGHT FRONT	A6	A6
RIGHT REAR	A5	A5
START BREW	A4	A4
LEFT HIDDEN	B1	B1
RIGHT HIDDEN	B2	B2
"DIGITAL"	D1	D1
"BREWER"	D2	D2
"CONTROL"	D3	D3

SCHEMATIC WIRING DIAGRAM AXIOM TWIN 2/2

**120/208V AC 3 WIRE + GND
120/240V AC 3 WIRE + GND
SINGLE PHASE**

CONTROL SWITCH ASSY CODES		
2 WARMERS 2 WARMERS	2 WARMERS	2 WARMERS
ON LEFT	ON TOP	ON RIGHT
BREW STATION	A3	A3
LEFT FRONT	A2	A3
LEFT REAR	A1	A5
TOP FRONT		A6
RIGHT FRONT		A5
RIGHT REAR		A4
START BREW	B1	B1
LEFT HIDDEN	B2	B2
RIGHT HIDDEN	D1	D1
"BREWER"	D2	D2
"CONTROL"	D3	D3

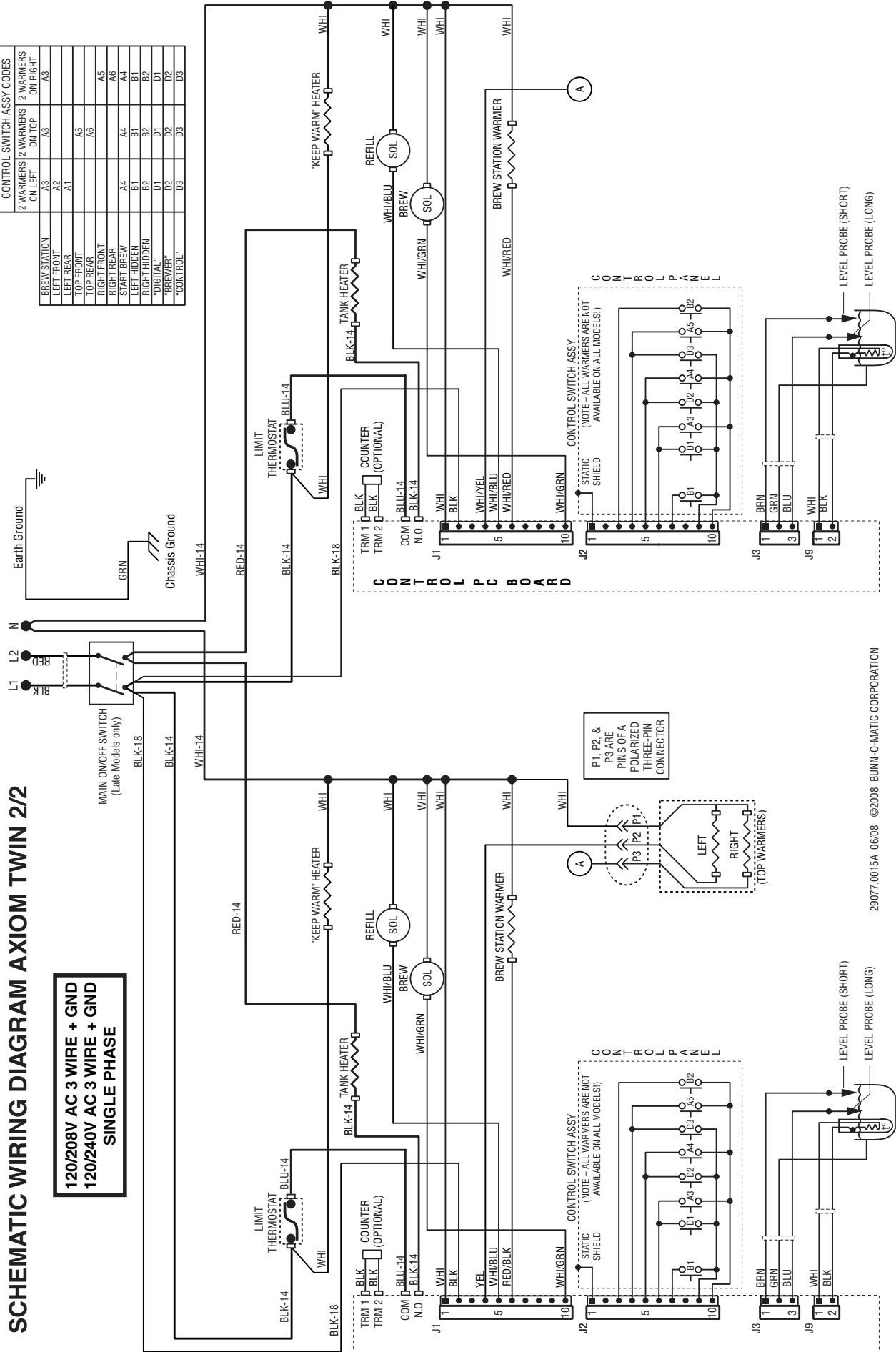

29077.0015A 06/08 ©2008 BUNN-O-MATIC CORPORATION

SCHEMATIC WIRING DIAGRAM AXIOM-APS

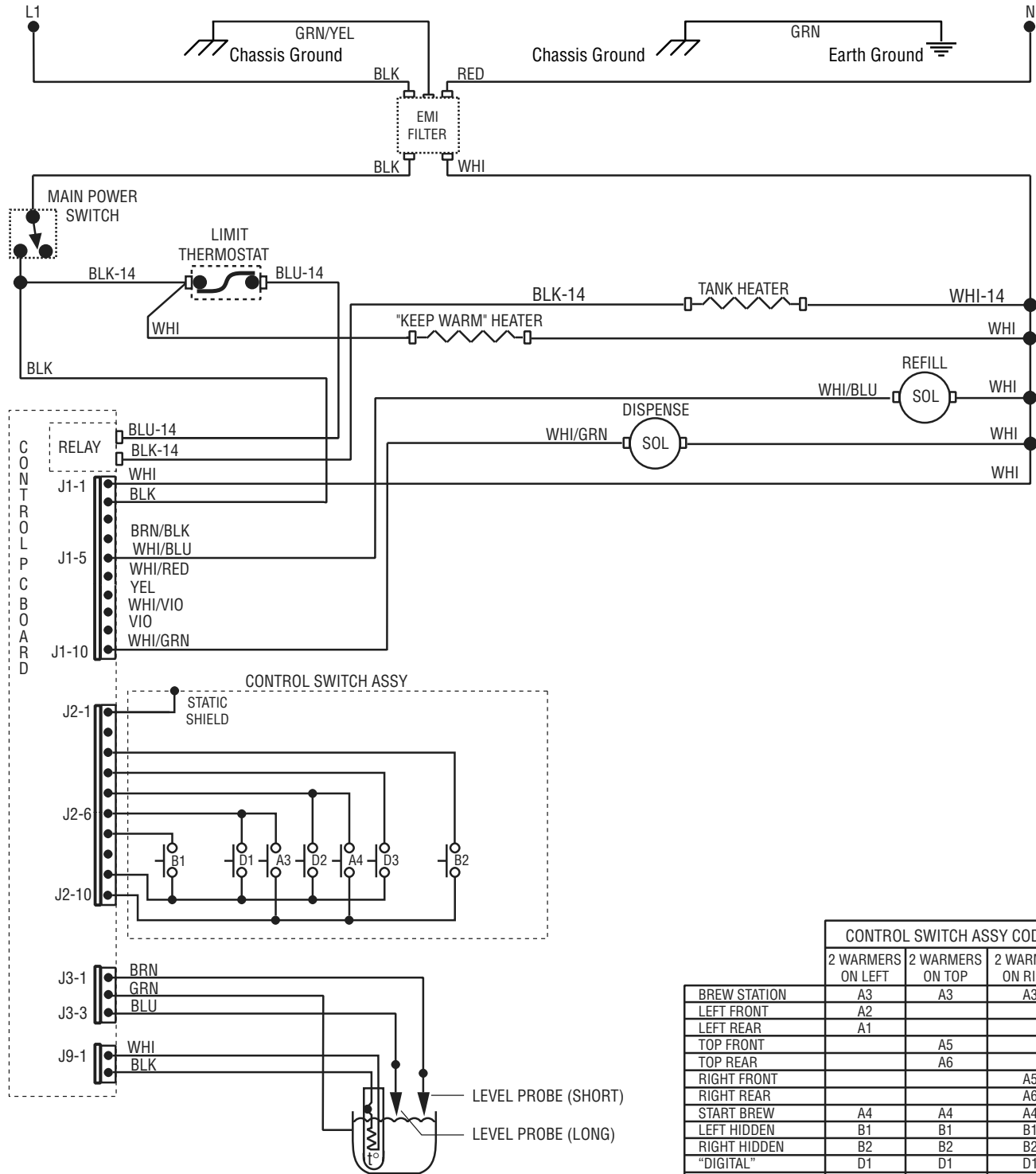

**100V AC
2 WIRE
SINGLE PHASE**

29077.0016B 11/09 ©2008 BUNN-O-MATIC CORPORATION

	CONTROL SWITCH ASSY CODES		
	2 WARMERS ON LEFT	2 WARMERS ON TOP	2 WARMERS ON RIGHT
BREW STATION	A3	A3	A3
LEFT FRONT	A2		
LEFT REAR	A1		
TOP FRONT		A5	
TOP REAR		A6	
RIGHT FRONT			A5
RIGHT REAR			A6
START BREW	A4	A4	A4
LEFT HIDDEN	B1	B1	B1
RIGHT HIDDEN	B2	B2	B2
"DIGITAL"	D1	D1	D1
"BREWER"	D2	D2	D2
"CONTROL"	D3	D3	D3

SCHEMATIC WIRING DIAGRAM AXIOM-APS

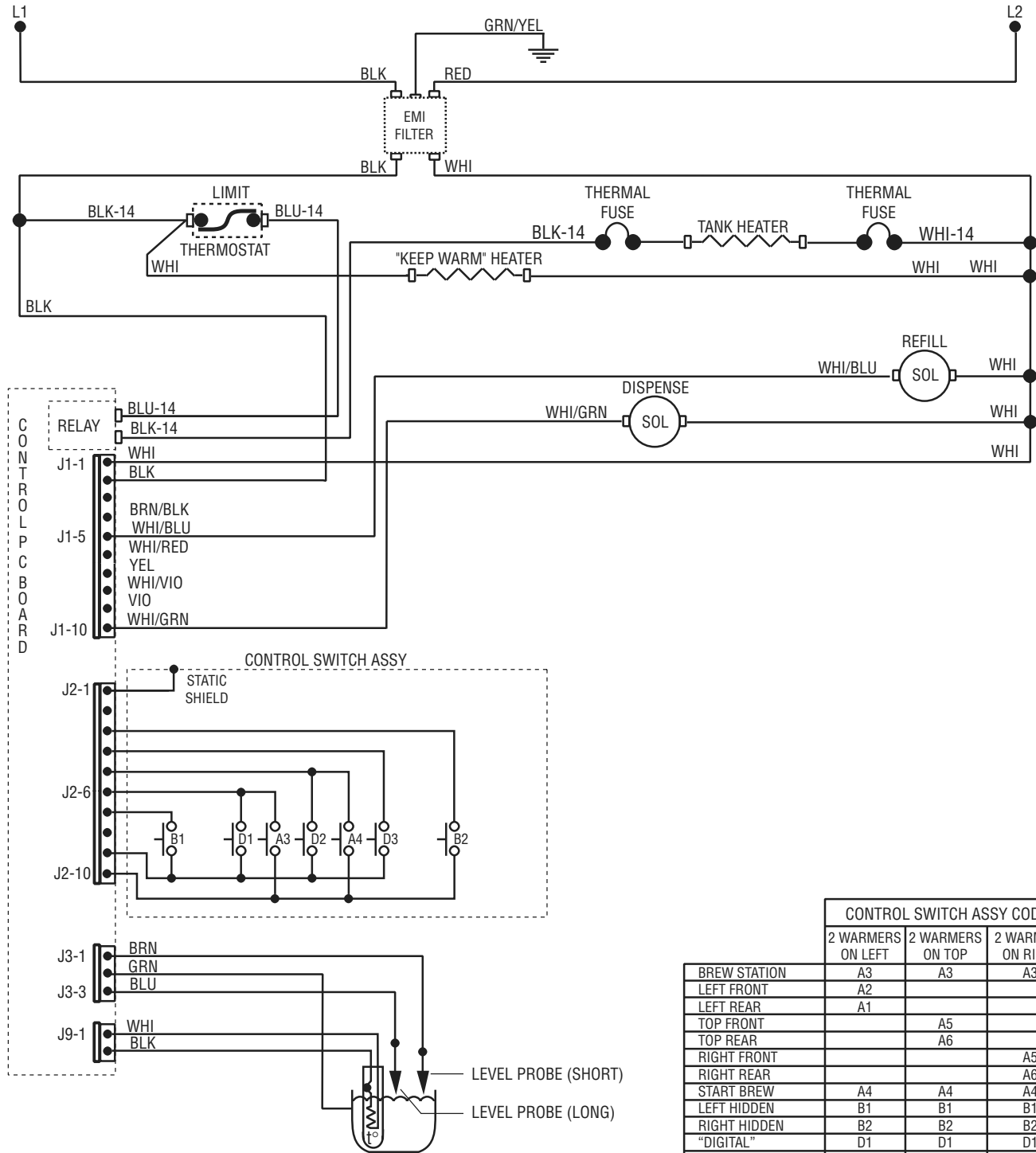

CONTROL BOARD

J1-1
J1-5
J1-10

- RELAY
- BLU-14
- BLK-14
- WHI
- BLK
- BRN/BLK
- WHI/BLU
- WHI/RED
- YEL
- WHI/VIO
- VIO
- WHI/GRN

CONTROL SWITCH ASSY

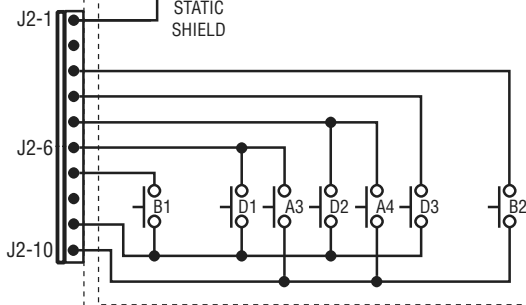

- J2-1
- J2-6
- J2-10
- J3-1
- J3-3
- J9-1

- BRN
- GRN
- BLU
- WHI
- BLK

LEVEL PROBE (SHORT)
LEVEL PROBE (LONG)

CONTROL SWITCH ASSY CODES

	2 WARMERS ON LEFT	2 WARMERS ON TOP	2 WARMERS ON RIGHT
BREW STATION	A3	A3	A3
LEFT FRONT	A2		
LEFT REAR	A1		
TOP FRONT		A5	
TOP REAR		A6	
RIGHT FRONT			A5
RIGHT REAR			A6
START BREW	A4	A4	A4
LEFT HIDDEN	B1	B1	B1
RIGHT HIDDEN	B2	B2	B2
"DIGITAL"	D1	D1	D1
"BREWER"	D2	D2	D2
"CONTROL"	D3	D3	D3

**230 VOLTS CE
2 WIRE + GND
SINGLE PHASE
50 HZ**

29077.0017A 10/08 ©2008 BUNN-O-MATIC CORPORATION

SCHEMATIC WIRING DIAGRAM AXIOM DV-APS/TC

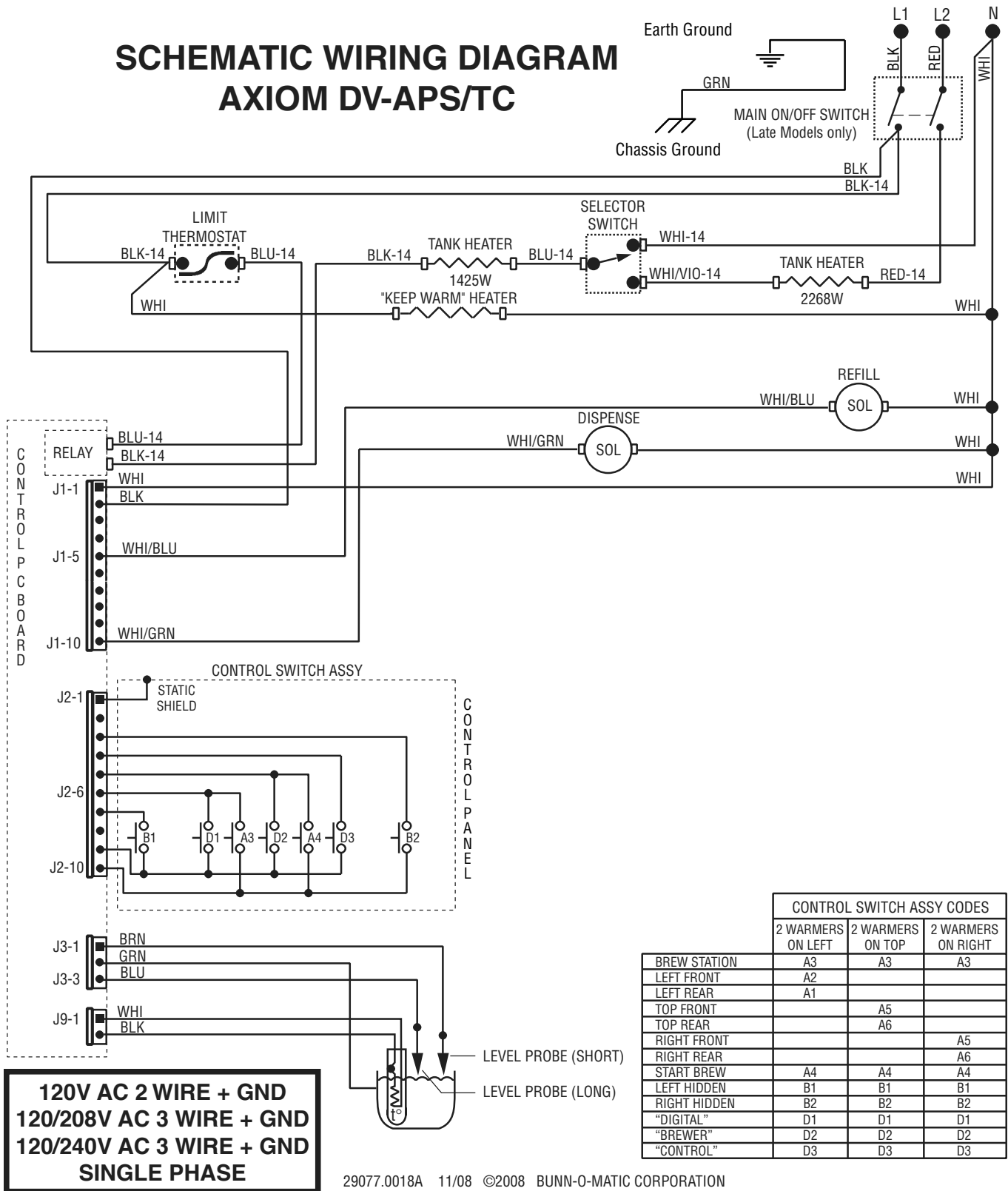

SCHEMATIC WIRING DIAGRAM SINGLE AXIOM - 15, 20 & 35

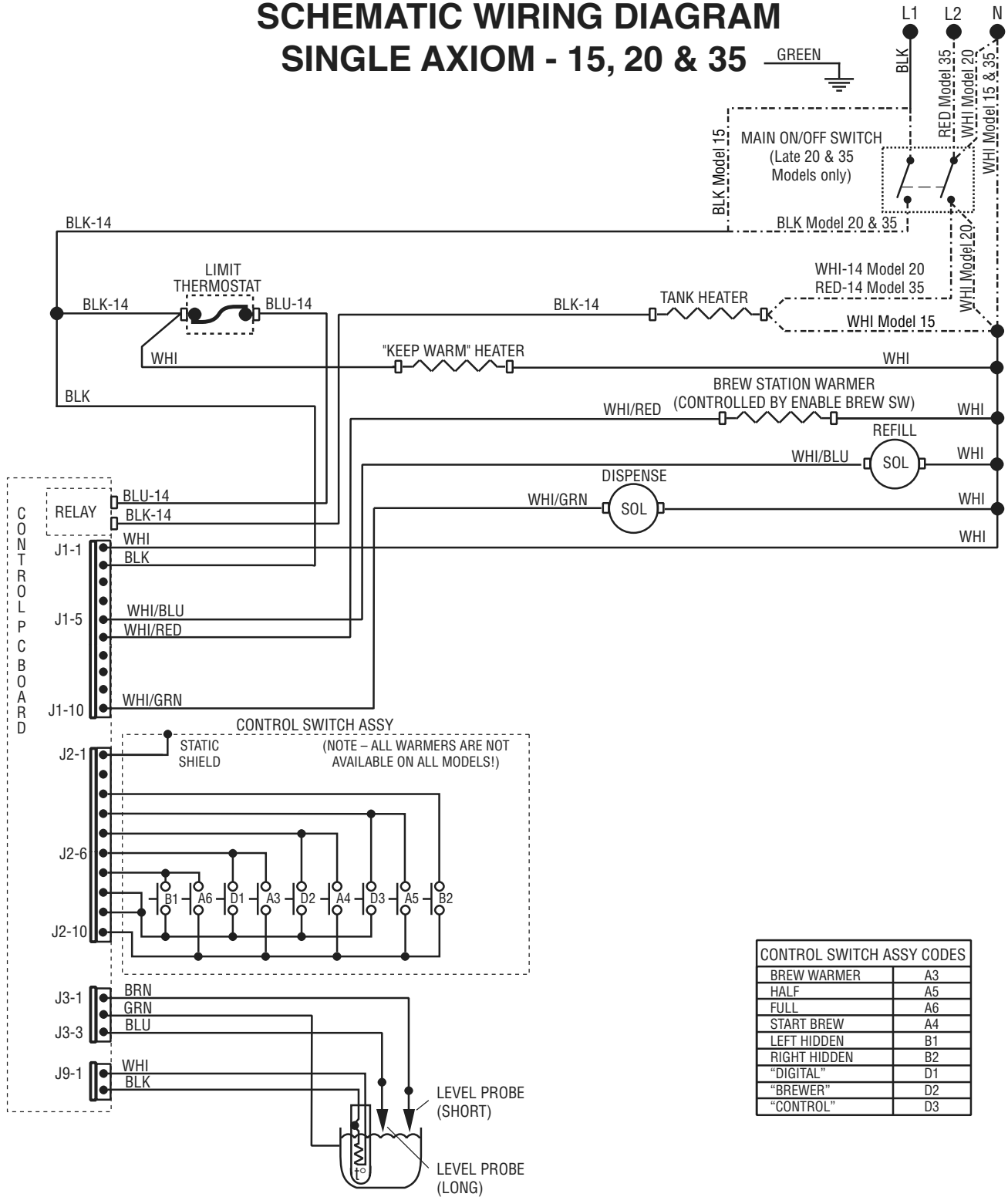

CONTROL SWITCH ASSY CODES	
BREW WARMER	A3
HALF	A5
FULL	A6
START BREW	A4
LEFT HIDDEN	B1
RIGHT HIDDEN	B2
"DIGITAL"	D1
"BREWER"	D2
"CONTROL"	D3

120V AC 2 WIRE
120/208V AC 3 WIRE
120/240V AC 3 WIRE
SINGLE PHASE

29077.0019A 03/09 ©2009 BUNN-O-MATIC CORPORATION

SCHEMATIC WIRING DIAGRAM AXIOM

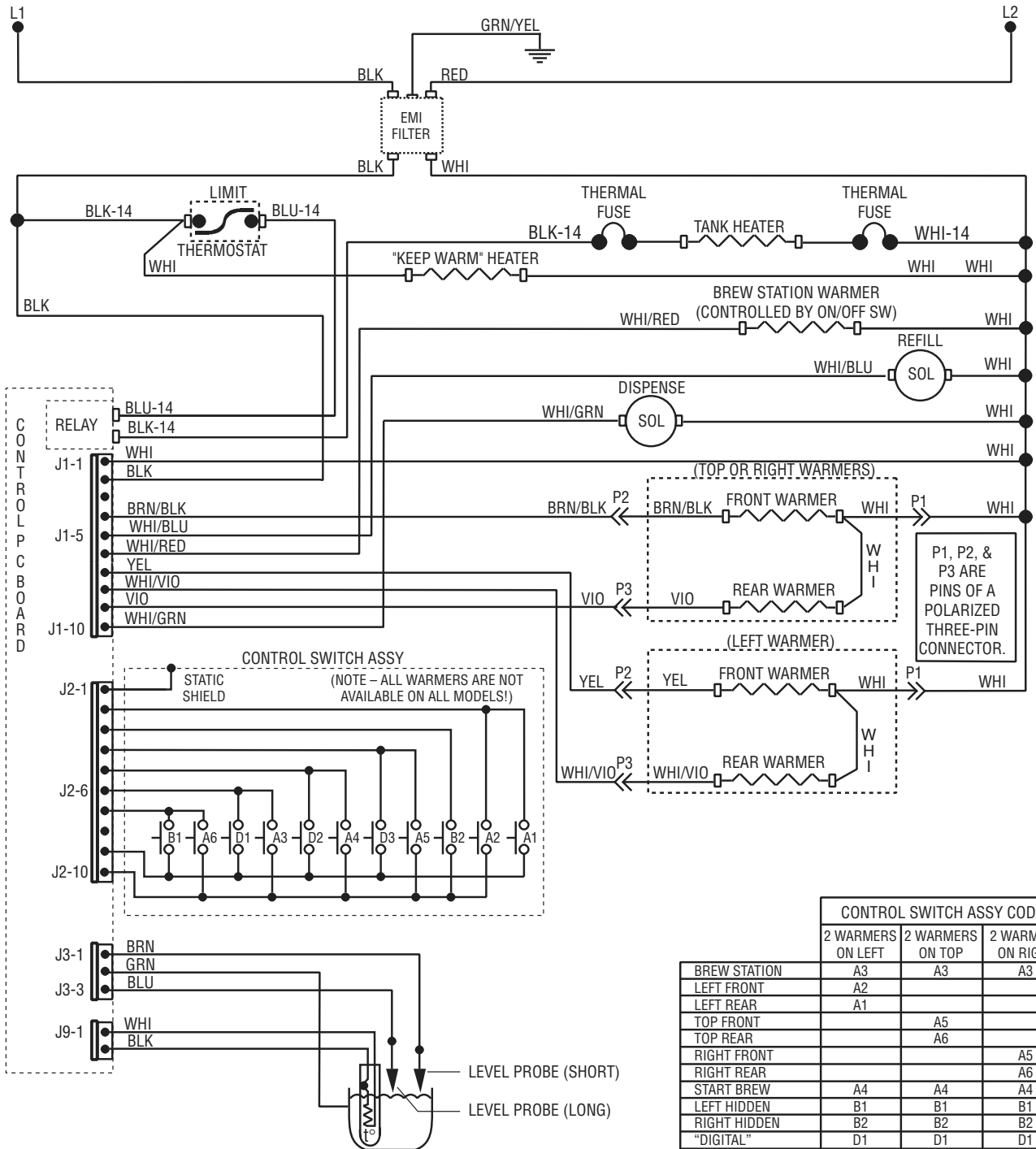

SCHEMATIC WIRING DIAGRAM AXIOM TWIN AP5/TC

BREWERS WITH 1 POWER CORD ONLY

120/208V AC 3 WIRE + GND
120/240V AC 3 WIRE + GND
SINGLE PHASE

Harness, Switch to Term Block
P/N 38920.0002

MAIN ON/OFF SWITCH
(Late Models only)

CONTROL SWITCH ASSY CODES	
2 WARMERS 2 WARMERS ON LEFT	A3
2 WARMERS 2 WARMERS ON RIGHT	A3
BREW STATION	A2
LEFT FRONT	A1
LEFT REAR	A5
TOP FRONT	A6
TOP REAR	A5
RIGHT FRONT	A6
RIGHT REAR	A4
START BREW	B1
LEFT HIDDEN	B1
RIGHT HIDDEN	B2
"DIGITAL"	D1
"BREWER"	D2
"CONTROL"	D3

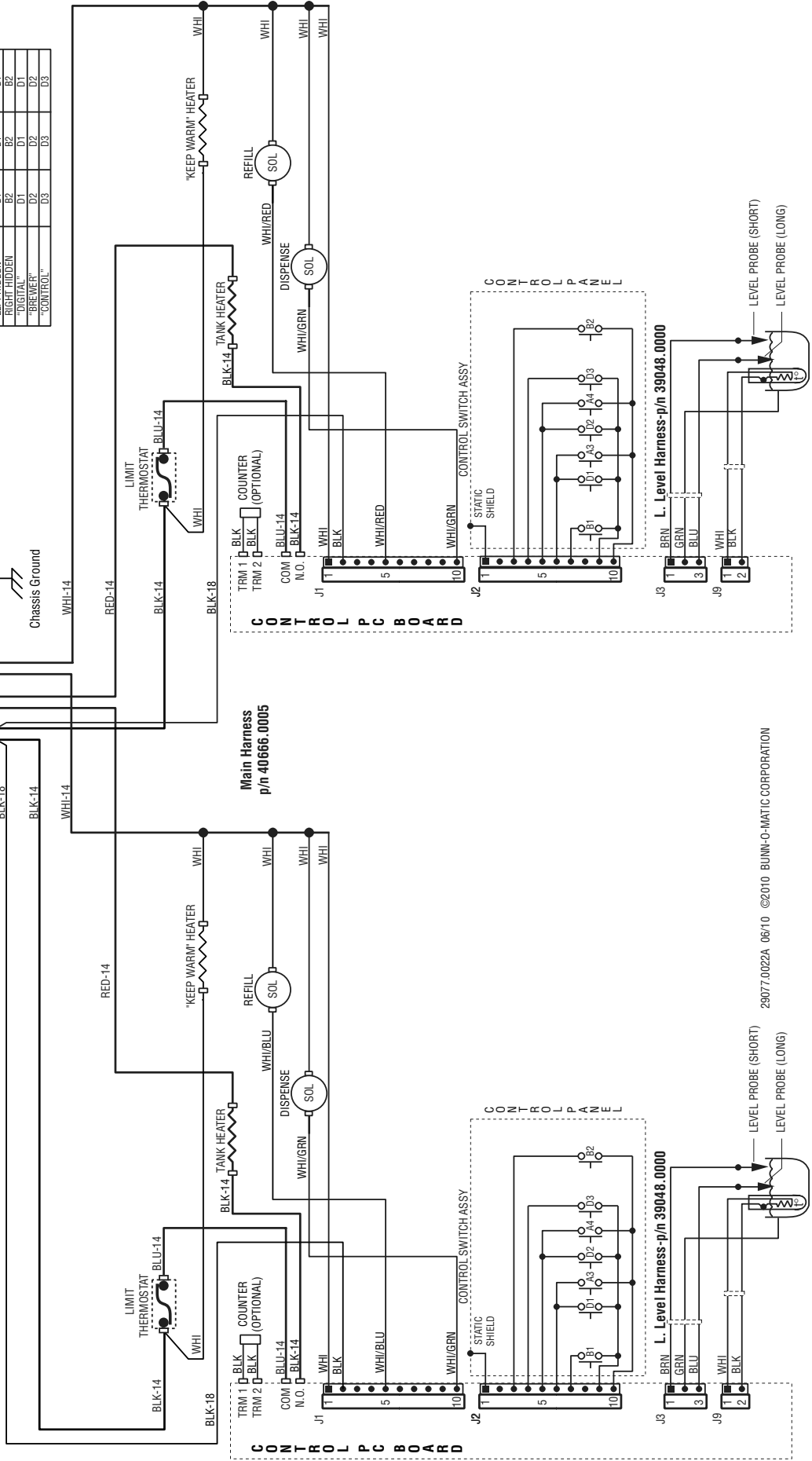

29077.0022A 06/10 ©2010 BUNN-O-MATIC CORPORATION

**SCHEMATIC WIRING DIAGRAM
AXIOM TWIN APS/TC**

**100-200 VOLTS AC
230 VOLTS AC CE
2 WIRE + GND
SINGLE PHASE 50-60 HZ**

CONTROL SWITCH ASSY CODES			
BEVER STATION	2 WARMERS ON LEFT	2 WARMERS ON TOP	2 WARMERS ON RIGHT
LEFT FRONT	A2	A3	A3
LEFT REAR	A1	A2	A3
TOP FRONT	A6	A5	A6
TOP REAR	A5	A6	A6
RIGHT FRONT	A2	A2	A4
RIGHT REAR	A1	A2	A6
LEFT MIDDLE	B1	B1	B1
RIGHT MIDDLE	B2	B2	B2
DISPENSE	C1	C1	C1
REFILL	C2	C2	C2
CONTROL	C3	C3	C3

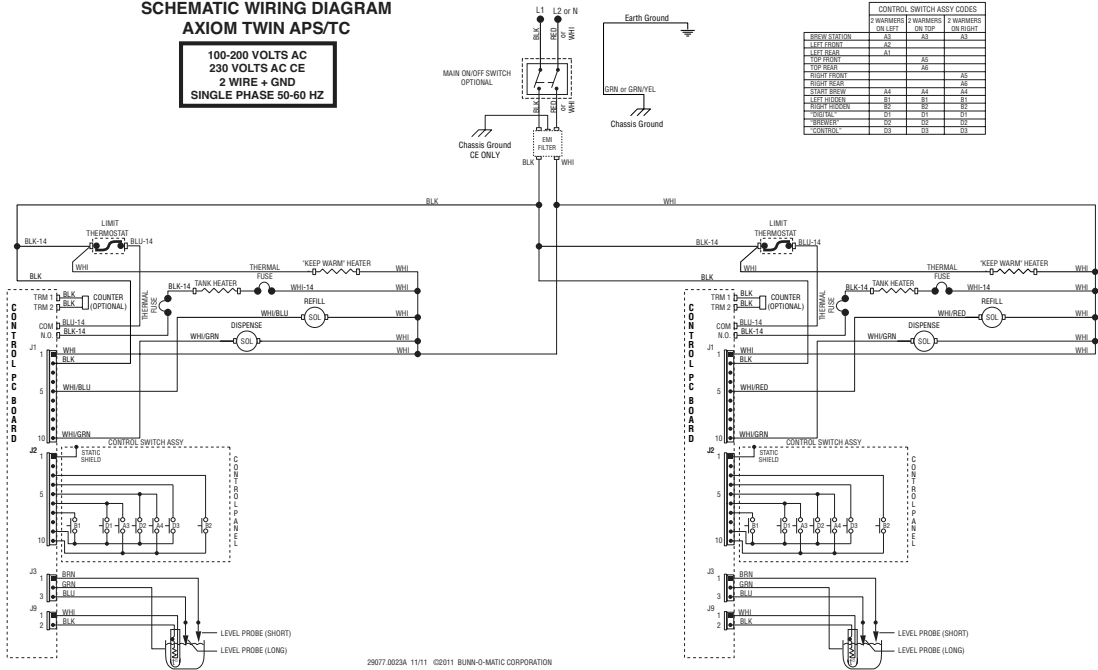

29077.0023A 11/11 ©2011 BUNN-O-MATIC CORPORATION

SCHEMATIC WIRING DIAGRAM AXIOM TS

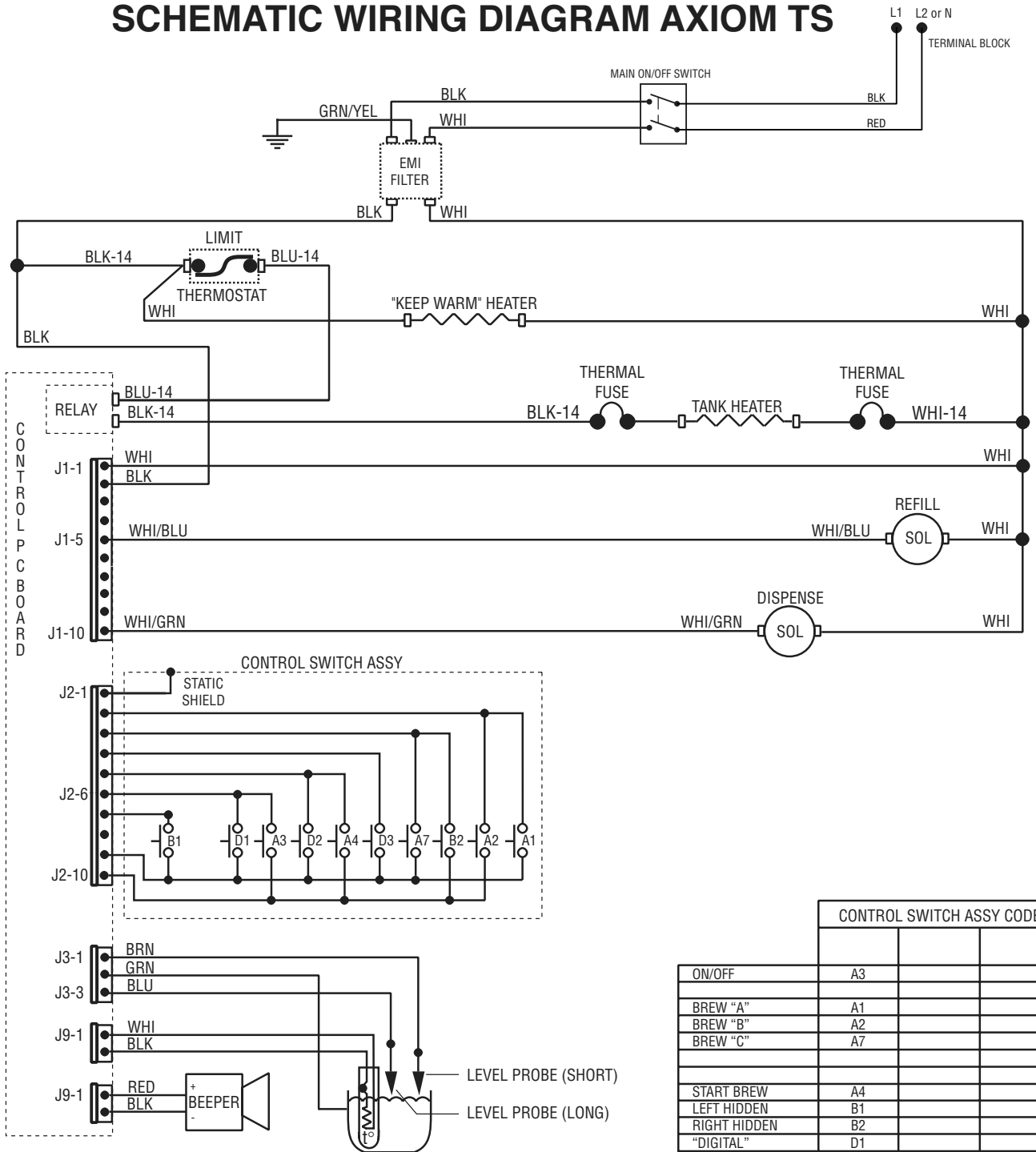

100-200 VOLTS
2 WIRE + GND
SINGLE PHASE
50/60 HZ

29077.0025A 10/11 ©2011 BUNN-O-MATIC CORPORATION

CONTROL SWITCH ASSY CODES			
ON/OFF	A3		
BREW "A"	A1		
BREW "B"	A2		
BREW "C"	A7		
START BREW	A4		
LEFT HIDDEN	B1		
RIGHT HIDDEN	B2		
"DIGITAL"	D1		
"BREWER"	D2		
"CONTROL"	D3		

SCHEMATIC WIRING DIAGRAM AXIOM TWIN 4/2

**120/208V AC 3 WIRE + GND
120/240V AC 3 WIRE + GND
SINGLE PHASE**

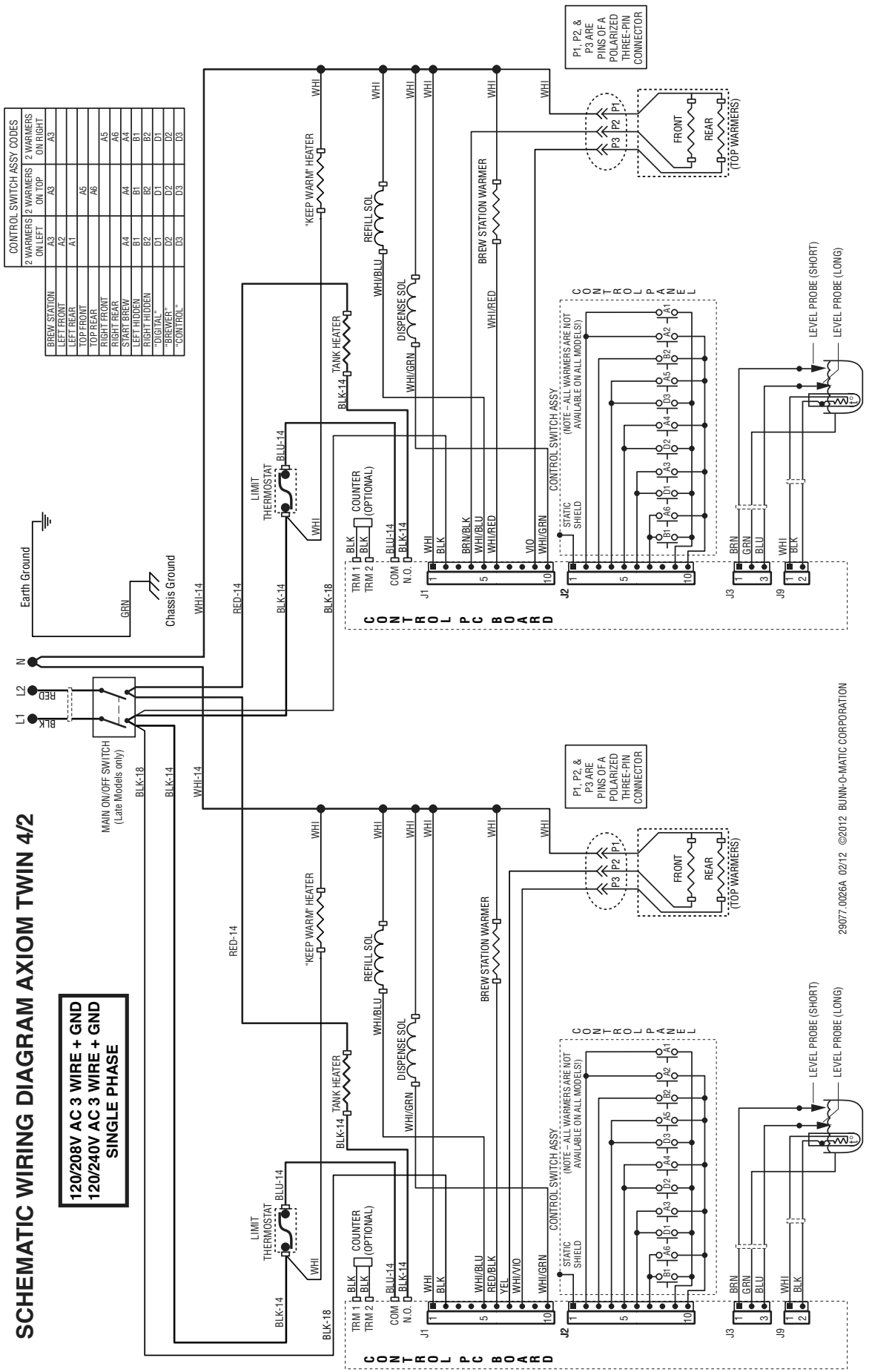

29077-0026A 02/12 ©2012 BUINN-O-MATIC CORPORATION