

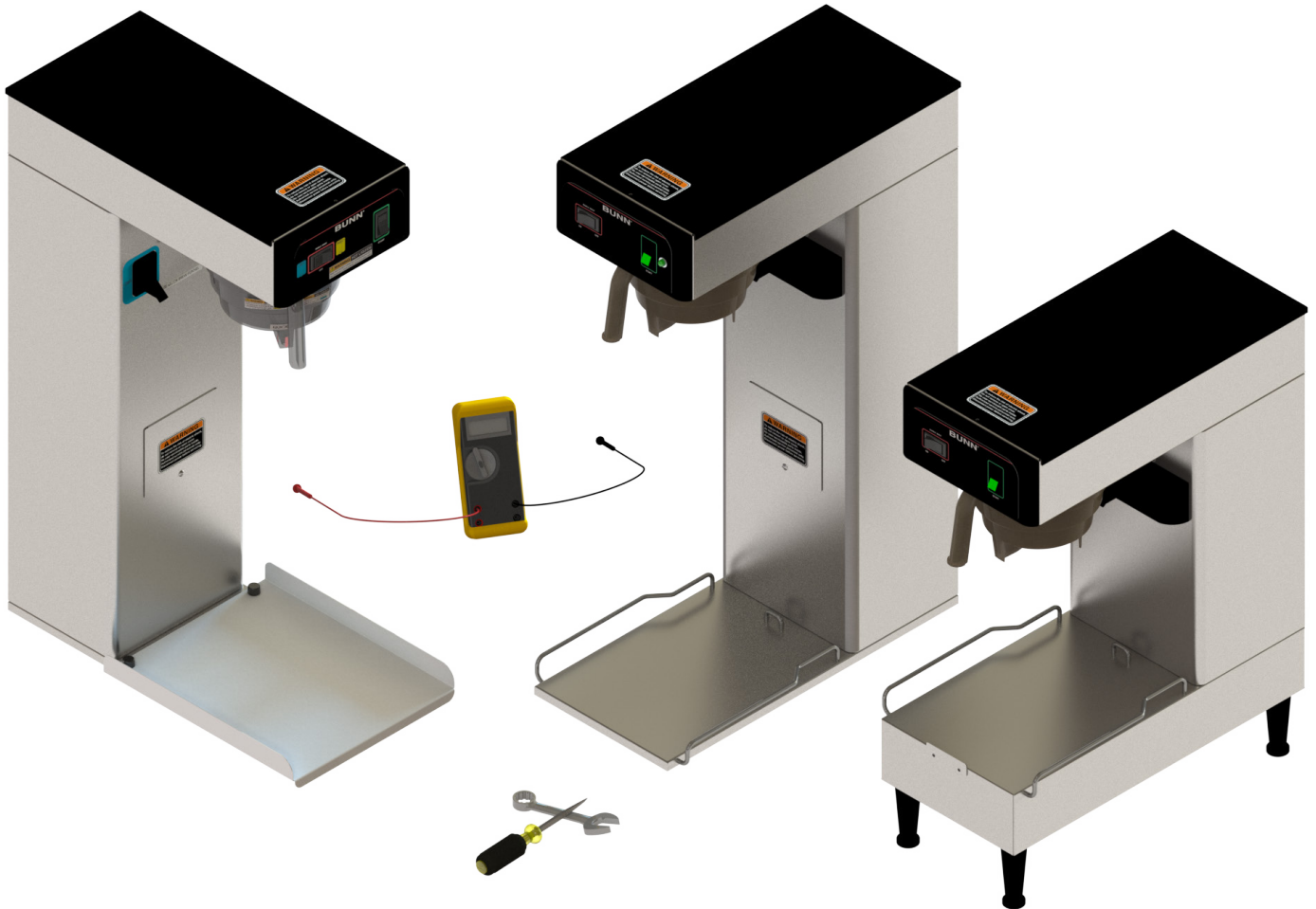

***TB3/TB6 Series***  
***Including: TB3; TB3-LP;***  
***TB3Q; TB3Q-LP; TB6; TB6Q***  
***STARTING WITH SERIAL NUMBER: TU00020000***



# **SERVICE & REPAIR MANUAL**

## **BUNN-O-MATIC CORPORATION**

POST OFFICE BOX 3227  
SPRINGFIELD, ILLINOIS 62708-3227  
PHONE: (217) 529-6601 FAX: (217) 529-6644

## BUNN-O-MATIC COMMERCIAL PRODUCT WARRANTY

Bunn-O-Matic Corp. ("BUNN") warrants equipment manufactured by it as follows:

- 1) Airpots, thermal carafes, decanters, GPR servers, iced tea/coffee dispensers, MCR/MCP/MCA single cup brewers, thermal servers and ThermoFresh® servers (mechanical and digital) 1 year parts and 1 year labor.
- 2) All other equipment - 2 years parts and 1 year labor plus added warranties as specified below:
  - a) Electronic circuit and/or control boards - parts and labor for 3 years.
  - b) Compressors on refrigeration equipment - 5 years parts and 1 year labor.
  - c) Grinding burrs on coffee grinding equipment to grind coffee to meet original factory screen sieve analysis - parts and labor for 4 years or 40,000 pounds of coffee, whichever comes first.

These warranty periods run from the date of installation BUNN warrants that the equipment manufactured by it will be commercially free of defects in material and workmanship existing at the time of manufacture and appearing within the applicable warranty period. This warranty does not apply to any equipment, component or part that was not manufactured by BUNN or that, in BUNN's judgment, has been affected by misuse, neglect, alteration, improper installation or operation, improper maintenance or repair, non periodic cleaning and descaling, equipment failures related to poor water quality, damage or casualty. In addition, the warranty does not apply to replacement of items subject to normal use including but not limited to user replaceable parts such as seals and gaskets. This warranty is conditioned on the Buyer 1) giving BUNN prompt notice of any claim to be made under this warranty by telephone at (217) 529-6601 or by writing to Post Office Box 3227, Springfield, Illinois 62708-3227; 2) if requested by BUNN, shipping the defective equipment prepaid to an authorized BUNN service location; and 3) receiving prior authorization from BUNN that the defective equipment is under warranty.

**THE FOREGOING WARRANTY IS EXCLUSIVE AND IS IN LIEU OF ANY OTHER WARRANTY, WRITTEN OR ORAL, EXPRESS OR IMPLIED, INCLUDING, BUT NOT LIMITED TO, ANY IMPLIED WARRANTY OF EITHER MERCHANTABILITY OR FITNESS FOR A PARTICULAR PURPOSE.** The agents, dealers or employees of BUNN are not authorized to make modifications to this warranty or to make additional warranties that are binding on BUNN. Accordingly, statements by such individuals, whether oral or written, do not constitute warranties and should not be relied upon.

If BUNN determines in its sole discretion that the equipment does not conform to the warranty, BUNN, at its exclusive option while the equipment is under warranty, shall either 1) provide at no charge replacement parts and/or labor (during the applicable parts and labor warranty periods specified above) to repair the defective components, provided that this repair is done by a BUNN Authorized Service Representative; or 2) shall replace the equipment or refund the purchase price for the equipment.

**THE BUYER'S REMEDY AGAINST BUNN FOR THE BREACH OF ANY OBLIGATION ARISING OUT OF THE SALE OF THIS EQUIPMENT, WHETHER DERIVED FROM WARRANTY OR OTHERWISE, SHALL BE LIMITED, AT BUNN'S SOLE OPTION AS SPECIFIED HEREIN, TO REPAIR, REPLACEMENT OR REFUND.**

In no event shall BUNN be liable for any other damage or loss, including, but not limited to, lost profits, lost sales, loss of use of equipment, claims of Buyer's customers, cost of capital, cost of down time, cost of substitute equipment, facilities or services, or any other special, incidental or consequential damages.

392, A Partner You Can Count On, Air Infusion, AutoPOD, AXIOM, BrewLOGIC, BrewMETER, Brew Better Not Bitter, BrewWISE, BrewWIZARD, BUNN Espresso, BUNN Family Gourmet, BUNN Gourmet, BUNN Pour-O-Matic, BUNN, BUNN with the stylized red line, BUNNlink, Bunn-OMatic, Bunn-O-Matic, BUNNserve, BUNNSERVE with the stylized wrench design, Cool Froth, DBC, Dr. Brew stylized Dr. design, Dual, Easy Pour, EasyClear, EasyGard, FlavorGard, Gourmet Ice, Gourmet Juice, High Intensity, iMIX, Infusion Series, Intellisteam, My Café, Phase Brew, PowerLogic, Quality Beverage Equipment Worldwide, Respect Earth, Respect Earth with the stylized leaf and coffee cherry design, Safety-Fresh, savemycoffee.com, Scale-Pro, Silver Series, Single, Smart Funnel, Smart Hopper, SmartWAVE, Soft Heat, SplashGard, The Mark of Quality in Beverage Equipment Worldwide, ThermoFresh, Titan, trifacta, TRIFECTA (stylized logo), Velocity Brew, Air Brew, Beverage Bar Creator, Beverage Profit Calculator, Brew better, not bitter., Build-A-Drink, BUNNSource, Coffee At Its Best, Cyclonic Heating System, Daypart, Digital Brewer Control, Element, Milk Texturing Fusion, Nothing Brews Like a BUNN, Picture Prompted Cleaning, Pouring Profits, Signature Series, Sure Tamp, Tea At Its Best, The Horizontal Red Line, Ultra are either trademarks or registered trademarks of Bunn-O-Matic Corporation. The commercial trifacta® brewer housing configuration is a trademark of Bunn-O-Matic Corporation.

## Contents

|                                 |    |
|---------------------------------|----|
| Trouble Shooting.....           | 4  |
| Component Access .....          | 10 |
| Control Thermostat.....         | 10 |
| Limit Thermostat.....           | 12 |
| Tank Heater .....               | 13 |
| Lighted ON/OFF Switch .....     | 14 |
| Non Lighted ON/OFF Switch.....  | 15 |
| Start Switches.....             | 16 |
| Inlet Solenoids .....           | 17 |
| Dual Timer (TB3/TB6) .....      | 18 |
| Digital Timer (TB3Q/TB6Q) ..... | 20 |
| Schematic Wiring Diagrams.....  | 22 |

## TROUBLESHOOTING

A troubleshooting guide is provided to suggest probable causes and remedies for the most likely problems encountered. If the problem remains after exhausting the troubleshooting steps, contact the Bunn-O-Matic Technical Service Department.

- Inspection, testing, and repair of electrical equipment should be performed only by qualified service personnel.
- All electronic components have 120 volt ac and low voltage dc potential on their terminals. Shorting of terminals or the application of external voltages may result in board failure.
- Intermittent operation of electronic circuit boards is unlikely. Board failure will normally be permanent. If an intermittent condition is encountered, the cause will likely be a switch contact or a loose connection at a terminal or crimp.
- Solenoid removal requires interrupting the water supply to the valve. Damage may result if solenoids are energized for more than ten minutes without a supply of water.
- The use of two wrenches is recommended whenever plumbing fittings are tightened or loosened. This will help to avoid twists and kinks in the tubing.
- Make certain that all plumbing connections are sealed and electrical connections tight and isolated.
- This brewer is heated at all times. Keep away from combustibles.

- WARNING** –
- Exercise extreme caution when servicing electrical equipment.
  - Unplug the brewer when servicing, except when electrical tests are specified.
  - Follow recommended service procedures
  - Replace all protective shields or safety notices

| PROBLEM                   | PROBABLE CAUSE                                                    | REMEDY                                                                                                                                                                                                                                                                                                                                                     |
|---------------------------|-------------------------------------------------------------------|------------------------------------------------------------------------------------------------------------------------------------------------------------------------------------------------------------------------------------------------------------------------------------------------------------------------------------------------------------|
| Brew cycle will not start | 1. No water<br><br>2. No power or incorrect voltage to the brewer | Water lines and valves to the brewer must be open.<br><br>(A1) Check the wire crimps for 120 volts across the black and white terminals on two wire 120 volt brewers.<br>(A2) Check the wire crimps for 200 volts on "B Series" brewers or 230 volts on "A Series" brewers across the red and black terminals.<br><br>(B) Check circuit breakers or fuses. |

## TROUBLESHOOTING (cont.)

| PROBLEM                           | PROBABLE CAUSE                               | REMEDY                                                                                                                                                                    |
|-----------------------------------|----------------------------------------------|---------------------------------------------------------------------------------------------------------------------------------------------------------------------------|
| Brew cycle will not start (cont.) | 3. ON/OFF Switch                             | Refer to Service - ON/OFF Switch for testing.                                                                                                                             |
|                                   | 4. Start Switch                              | Refer to Service - Start Switch for testing procedures.                                                                                                                   |
|                                   | 5. Timer                                     | Refer to Service - Timer for testing procedures.                                                                                                                          |
|                                   | 6. Solenoid Valve                            | Refer to Service - Solenoid Valve for testing procedures.                                                                                                                 |
|                                   | 7. Water strainer/flow control (If equipped) | (A) Direction of flow arrow must be pointing towards brewer.                                                                                                              |
|                                   |                                              | (B) Remove the strainer/flow control and check for obstructions. Clear or replace.                                                                                        |
|                                   | Water is not hot                             | 1. (A) Limit Thermostat<br>(B) Thermal Cut-Off (230V)<br><b>CAUTION</b> - Do not eliminate or bypass limit thermostat or thermal cut-off. Use only BOM replacement parts. |
| 2. Control Thermostat             |                                              | Refer to Service - Control Thermostat for testing procedures.                                                                                                             |
| 3. Tank Heater                    |                                              | Refer to Service - Tank Heater for testing procedures.                                                                                                                    |

## TROUBLESHOOTING (cont.)

### PROBLEM

### PROBABLE CAUSE

### REMEDY

Inconsistent beverage level in dispenser

1. Strainer /flow control  
(If equipped)

(A) Direction of flow arrow must be pointing towards the brewer.

(B) Remove the strainer/flow control and check for obstruction. Clear or replace.

2. Syphon System

The brewer must be level or slightly lower in front to syphon properly.

3. Lime Build-up

**CAUTION** - Tank and tank components should be delimed regularly depending on local water conditions. Excessive mineral build-up on stainless steel surfaces can initiate corrosive reactions resulting in serious leaks.

Inspect the tank assembly for excessive lime deposits. Delime as required.

4. Water Pressure

The water pressure to the brewer must be at least 20 psi (138kPa) and minimum 1.0 gpm flow rate.

Consistently low beverage level in the dispenser

1. Timer

Timer dial must indicate at least two minutes and fifteen seconds. Refer to Operating Manual.

2. Strainer/flow Control  
(If equipped)

(A) Direction of flow arrow must be pointing towards brewer.

(B) Remove the strainer/flow control and check for obstructions. Clear or replace.

Spitting or excessive steaming

1. Lime Build-up

**CAUTION** - Tank and tank components should be delimed regularly depending on local water conditions. Excessive mineral build-up on stainless steel surfaces can initiate corrosive reactions resulting in serious leaks.

Inspect tank assembly for excessive lime deposits. Delime as required.

## TROUBLESHOOTING (cont.)

| PROBLEM                                                  | PROBABLE CAUSE                                                                                                                                                                                                                                     | REMEDY                                                                                           |
|----------------------------------------------------------|----------------------------------------------------------------------------------------------------------------------------------------------------------------------------------------------------------------------------------------------------|--------------------------------------------------------------------------------------------------|
| Spitting or excessive steaming (cont.)                   | 2. Control Thermostat                                                                                                                                                                                                                              | Refer to Service - Control Thermostat for testing procedures.                                    |
| Dripping from sprayhead                                  | 1. Syphon System                                                                                                                                                                                                                                   | The brewer must be level or slightly lower in front to syphon properly.                          |
|                                                          | 2. Lime Build-up<br><b>CAUTION</b> - Tank and tank components should be delimed regularly depending on local water conditions. Excessive mineral build-up on stainless steel surfaces can initiate corrosive reactions resulting in serious leaks. | Inspect the tank assembly for excessive lime deposits. Delime as required.                       |
|                                                          | 3. Solenoid Valve                                                                                                                                                                                                                                  | Remove the solenoid valve and clear any obstructions. Rebuild or replace the valve if necessary. |
| Water flows into tank continuously (ON/OFF Switch "ON")  | 1. Timer                                                                                                                                                                                                                                           | Refer to Service - Timer for testing procedures.                                                 |
| Water flows into tank continuously (ON/OFF Switch "OFF") | 1. Solenoid Valve                                                                                                                                                                                                                                  | Remove the Solenoid Valve and clean any obstruction. Rebuild or replace the valve if necessary.  |
| Beverage overflows dispenser                             | 1. Dispenser                                                                                                                                                                                                                                       | The dispenser must be completely empty before starting a brew cycle.                             |
|                                                          | 2. Timer                                                                                                                                                                                                                                           | Refer to Service - Timer for testing procedures.                                                 |
|                                                          | 3. Solenoid Valve                                                                                                                                                                                                                                  | Remove the Solenoid Valve and clean any obstruction. Rebuild or replace the valve if necessary.  |

## TROUBLESHOOTING (cont.)

### PROBLEM

### PROBABLE CAUSE

### REMEDY

Weak beverage

1. Filter Type

BUNN® paper filters must be used for proper extraction if loose leaf tea is being used.

2. Pouch Pack Tea

Verify pouch pack is seated in middle of funnel.

3. Sprayhead

A six-hole (or seven hole) sprayhead must be used for proper extraction. (Single hole sprayheads can be used with pouch packs).

4. Funnel Loading

The BUNN® paper filter must be centered in the funnel and the bed of ground leveled by gentle shaking.

5. Water Temperature

Place an empty funnel on an empty dispenser beneath the sprayhead. Initiate a brew cycle and check the water temperature immediately below the sprayhead with a thermometer. The reading should not be less than 200°F (93°C). Adjust the control thermostat to increase the water temperature. Replace if necessary.

Dry tea leaves remain in the funnel

1. Funnel Tip Missing

Check that funnel tip and screen are still assembled on the funnel.

Brewer is making unusual noises

1. Solenoid

The nut on the solenoid must be tight or it will vibrate during operation.

2. Plumbing Lines

Plumbing lines should not resting on the counter top.

3. Water Supply

(A) The brewer must be connected to a cold water line.

(B) Water pressure to the brewer must not exceed 90 psi (620 kPa). Install a regulator if necessary to lower the working pressure to approximately 50 psi (345 kPa).

**TROUBLESHOOTING (cont.)**

**PROBLEM**

**PROBABLE CAUSE**

**REMEDY**

Brewer is making unusual noises  
(cont.)

4. Tank Heater

Remove and clean lime off the  
tank heater.

## SERVICE

This section provides procedures for testing and replacing various major components used in this brewer should service become necessary. Refer to Troubleshooting for assistance in determining the cause of any problem.

**WARNING** - Inspection, testing, and repair of electrical equipment should be performed only by qualified service personnel. The brewer should be unplugged when servicing, except when electrical tests are required and the test procedure specifically states to plug-in the brewer.

### COMPONENT ACCESS

**WARNING** - Disconnect the brewer from the power source before the removal of any panel or the replacement of any component.

All components are accessible by the removal of the top cover, front inspection panel, and rear panel.

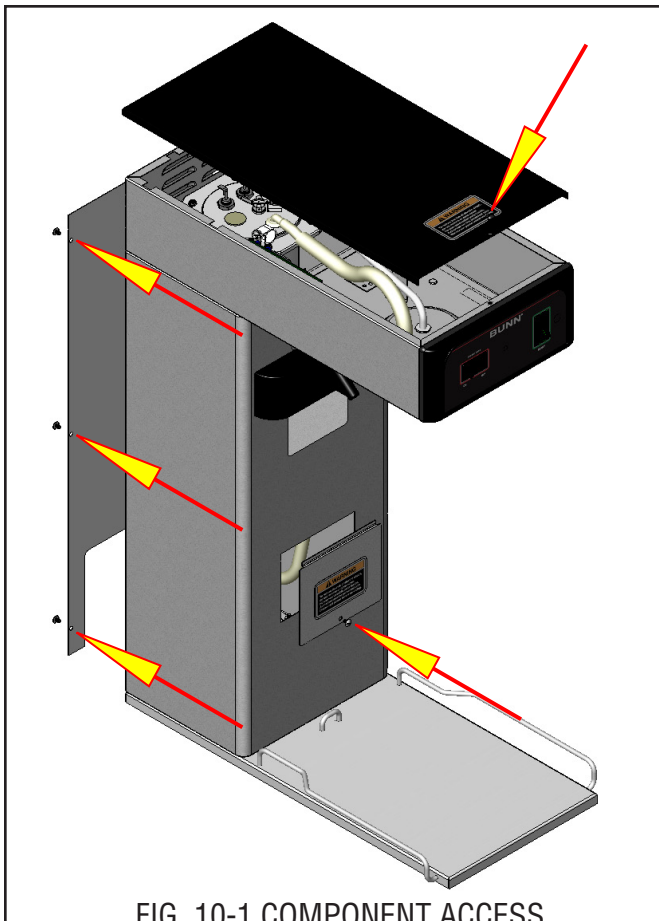

FIG. 10-1 COMPONENT ACCESS

## CONTROL THERMOSTAT

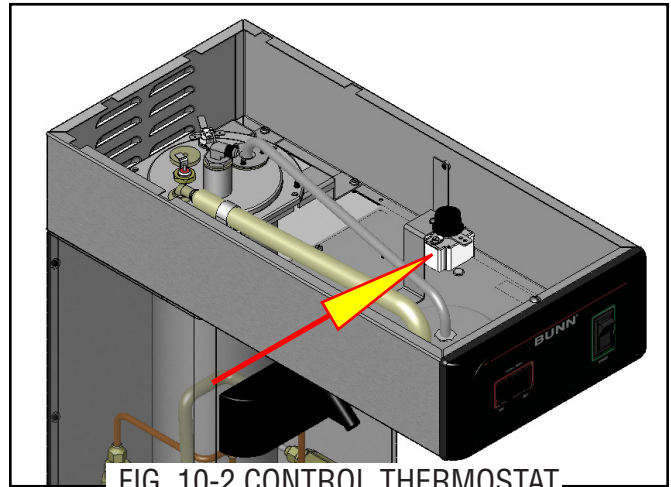

FIG. 10-2 CONTROL THERMOSTAT

### Location:

The control thermostat is located in the hood.

### Test Procedures:

1. Disconnect the brewer from the power source.
2. Locate the blue wire on the control thermostat.
3. Check the voltage across the blue/black wire on the control thermostat and the white wire on the tank heater on 120V models or red wire on the tank heater on two wire 200V or 230V models with a voltmeter. Connect the brewer to the power source. The indication must be:
  - a) 120 volts ac for two wire 120 volt models.
  - b) 200 to 230 volts ac for two wire 200 or 230 volt models.
4. Disconnect the brewer from the power source.

If voltage is present as described, proceed to #5.  
If voltage is not present as described, refer to the wiring diagrams and check the brewer wiring harness.

5. Locate the black wire on the control thermostat.
6. Gently remove the capillary bulb and grommet from the tank.
7. Check the voltage across the black wire of the control thermostat and the white wire on the tank heater on 120V models or red wire on the tank heater on two wire 200V or 230V models with a voltmeter when the control thermostat is turned fully clockwise. Connect the brewer to the power

**(CONTINUED)**

## SERVICE (cont.)

### CONTROL THERMOSTAT (cont.)

source. The indication must be:

- a) 120 volts ac for two wire 120 volt models.
- b) 200 to 230 volts ac for two wire 200 volt or 230 volt models.

8. Disconnect the brewer from the power source.

If voltage is present as described, reinstall the capillary tube into the tank to the line 4.5" above the bulb, the control thermostat is operating properly.

If voltage is not present as described, replace the thermostat.

#### **Removal and Replacement:**

1. Disconnect the control thermostat wires.
2. Remove the thermostat capillary bulb by firmly pulling-up on the capillary at the tank lid. This will disengage the grommet from the tank lid.
3. Remove the one #6-32 screw securing the control thermostat to the component bracket inside the hood.
4. Slide the grommet to the line 4.5" above the bulb on the new capillary tube.
5. Insert the capillary bulb through the hole in the tank lid and press the grommet firmly and evenly so that the groove in the grommet fits into the tank lid.
6. Carefully bend the capillary tube so that the tube and bulb inside the tank are in the vertical position.

**NOTE** - The capillary tube must be clear of any electrical termination and not kinked.

7. Using one #6-32 screw, secure the control thermostat to the component bracket inside the hood.
8. Adjust the control thermostat as required.

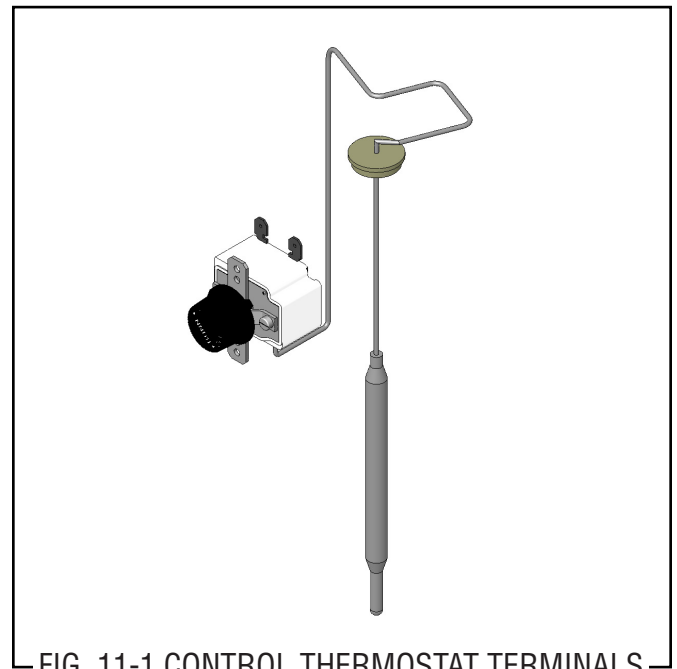

FIG. 11-1 CONTROL THERMOSTAT TERMINALS

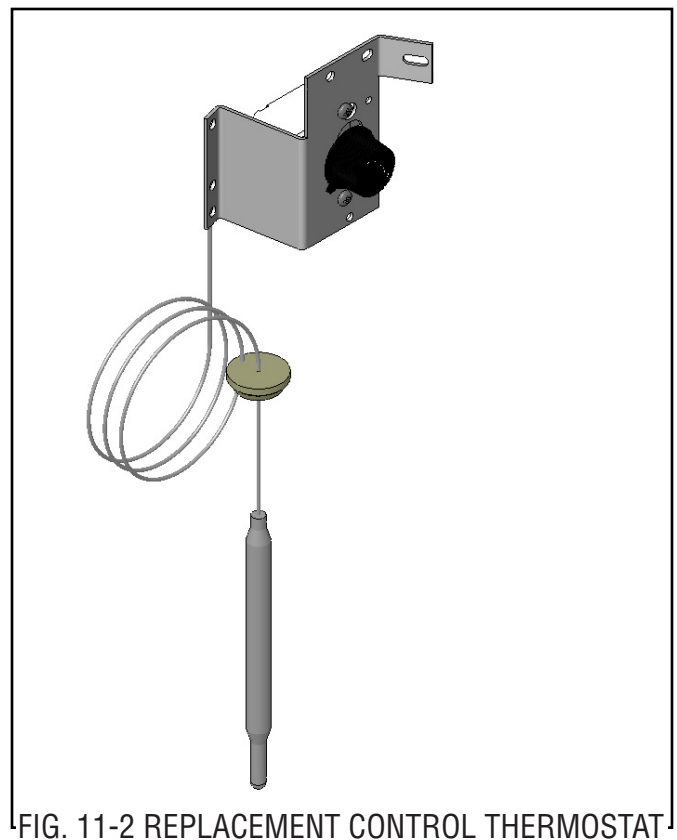

FIG. 11-2 REPLACEMENT CONTROL THERMOSTAT

**SERVICE (cont.)**  
**LIMIT THERMOSTAT**

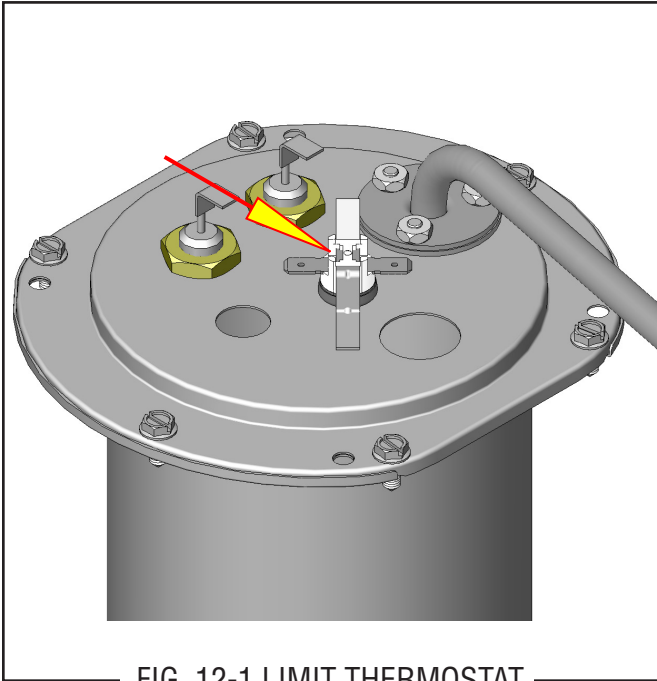

FIG. 12-1 LIMIT THERMOSTAT

**Location:**

The limit thermostat is located inside the rear of the hood on the tank lid.

**Test Procedures:**

1. Disconnect the brewer from the power source.
2. Disconnect the blue and black wires from the limit thermostat.
3. Check for continuity across the limit thermostat terminals with a ohmmeter.

If continuity is present as described, the limit thermostat is operating properly.

If continuity is not present as described, replace the limit thermostat.

**Removal and Replacement:**

1. Remove all wires from limit thermostat terminals.
2. Carefully slide the limit thermostat out from under the retaining clip and remove limit thermostat.
3. Carefully slide the new limit thermostat into the retaining clip.
4. Refer to the schematics when reconnecting the wires.

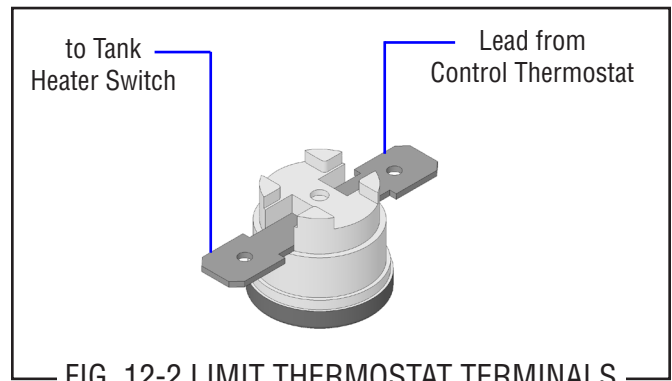

FIG. 12-2 LIMIT THERMOSTAT TERMINALS

## SERVICE (cont.)

### TANK HEATER

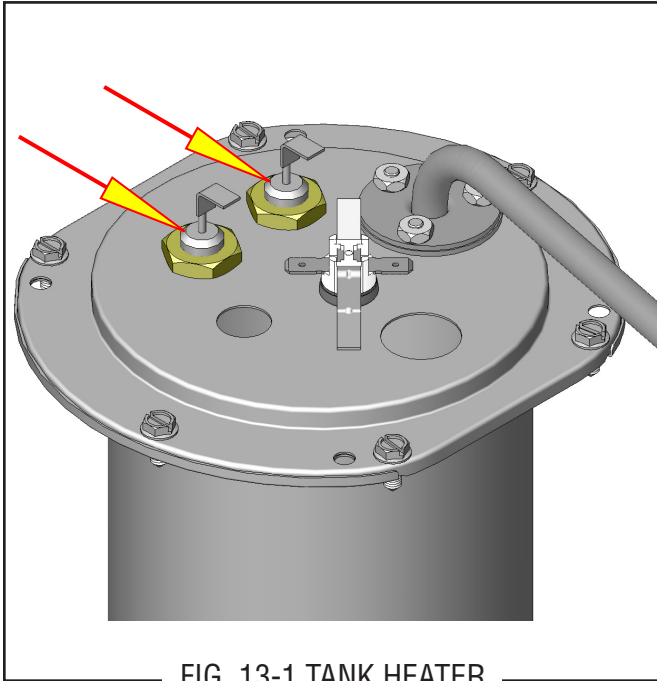

FIG. 13-1 TANK HEATER

#### **Location:**

The tank heater is located inside the tank and secured to the tank lid.

#### **Test Procedures:**

1. Disconnect the brewer from the power supply.
2. Turn on thermostat. Check the voltage across the black and white wires on 120 volt models or the black and red wires for 200 volt models and 230 volt models with a voltmeter. Connect the brewer to the power source. The indication must be:
  - a) 120 volts ac for two wire 120 volt 20 amp models .
  - b) 200 to 230 volts ac for two wire 200 or 230 volt models.
3. Disconnect the brewer from the power source.

If voltage is present as described, proceed to #4

If voltage is not present as described, refer to the Wiring Diagrams and check wiring harness.

4. Disconnect the wires from the tank heater terminals.
5. Check resistance value across tank heater terminals and compare to chart.

If resistance is present as described, reconnect the wires, the tank heater is ok.

If resistance is not present as described, replace the

| HEATER                               | RESISTANCE                   |
|--------------------------------------|------------------------------|
| 1680W-120V                           | 7.9 $\Omega$ - 9.2 $\Omega$  |
| 1680W-100V                           | 5.5 $\Omega$ -6.4 $\Omega$   |
| 1680W-230V                           | 29.0 $\Omega$ -33.7 $\Omega$ |
| TERMINAL TO SHEATH - INFINITE (OPEN) |                              |

tank heater.

**NOTE-** If any resistance is read between sheath and either terminal, remove and inspect heater for cracks in the sheath.

#### **Removal and Replacement:**

1. Disconnect the brewer from the power supply.
2. Disconnect the water supply from the brewer.
3. Disconnect the wires from the limit thermostat.
4. Disconnect the wires from the tank heater terminals.
5. Remove sprayhead and the hex nut securing the sprayhead tube to the hood. Set aside for reassembly.
6. Remove the six #10 screws securing the tank lid to the tank.
7. Remove the tank lid with limit thermostat, sprayhead tube and tank heater.
8. Remove the two hex nuts securing the tank heater to the tank lid. Remove tank heater with gaskets and discard.
9. Install new tank heater with gaskets on the tank lid and secure with two hex nuts.
10. Install tank lid with limit thermostat, sprayhead tube and tank heater using six #10 screws.
11. Secure sprayhead tube to hood using hex nut removed in step 4.
12. Install sprayhead.
15. Reconnect the wires to the limit thermostat and tank heater.
16. Reconnect the water and power supply.

## SERVICE (cont.)

### LIGHTED ON/OFF SWITCH (TB3/TB3Q)

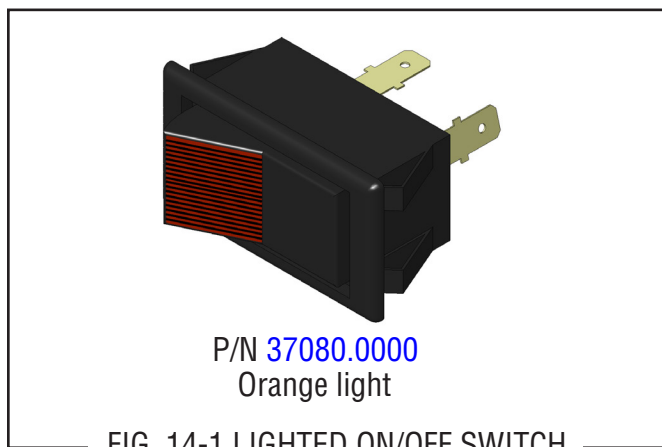

### Removal and Replacement:

1. Remove the wires from the switch terminals.
2. Compress the clips inside the hood and gently push the switch through the opening.
3. Push the new switch into the opening and spread the clips to hold the switch captive in the hood.
4. Refer to FIG. 14-2 when reconnecting the wires.

### Location:

The ON/OFF switch is located in the front of the hood, above and to the left of the brew funnel.

### Test Procedure:

#### Brewers W/Out Half Batch or Sweetener Options

1. Disconnect the brewer from the power source.
2. Remove the wires from all four terminals.
3. Check for continuity across the two terminals on the lower right of the switch (as shown). Continuity must be present across these terminals in the ON position.

If continuity is present as described, reconnect the wires, the switch is operating properly. If continuity is not present as described, replace the switch.

**NOTE:** No continuity will show across the upper left terminals of the lighted switch since the light is neon.

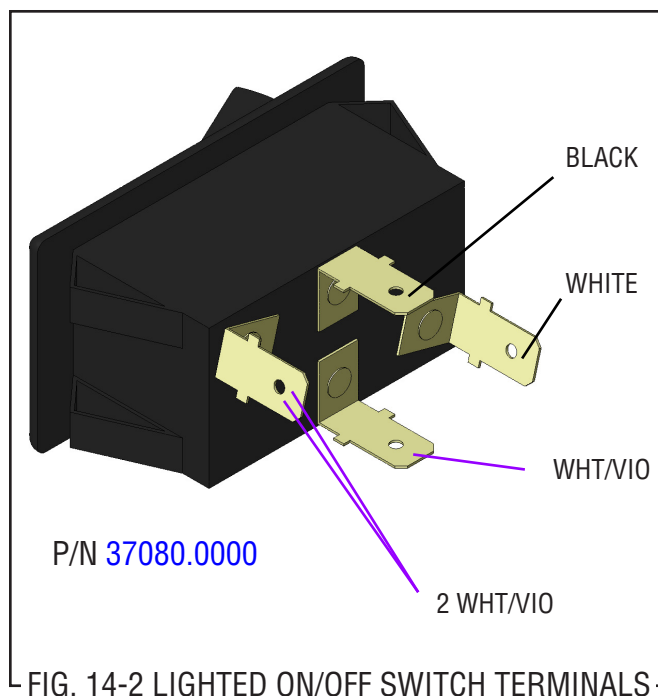

## SERVICE (cont.)

### ON/OFF SWITCH-TB6/Q (Sweetner ½ Batch Option-TB3/Q)

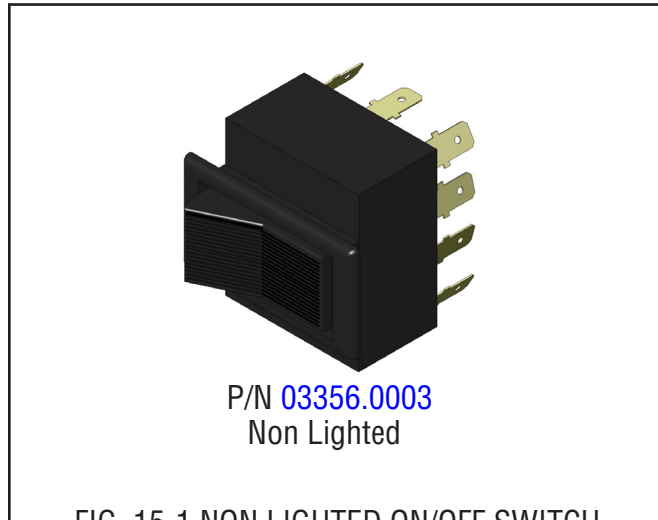

FIG. 15-1 NON LIGHTED ON/OFF SWITCH

#### **Location:**

The switch is located on the front control panel.

#### **Test Procedure:**

1. Disconnect the brewer from the power source.
2. Disconnect the wires from switch terminals.
3. Check for continuity across the center and right and across center and left terminals in rows one through four when the switch is in the opposite position.

If continuity is not present as described, replace the switch.

If continuity is present as described, replace the wires the switch is operating properly.

#### **Removal and Replacement:**

1. Remove the wires from the switch terminals.
2. Remove the clips on the switch bezel inside the hood and gently push the switch through the opening.
3. Push the new switch into the opening from inside the hood and secure into place by pressing the bezel through the front of the hood. Make sure the clips on the switch bezel are locked around the switch housing and spread the clips to hold the switch captive in the hood.
4. Refer to FIG. 15-2 when reconnecting the wires.

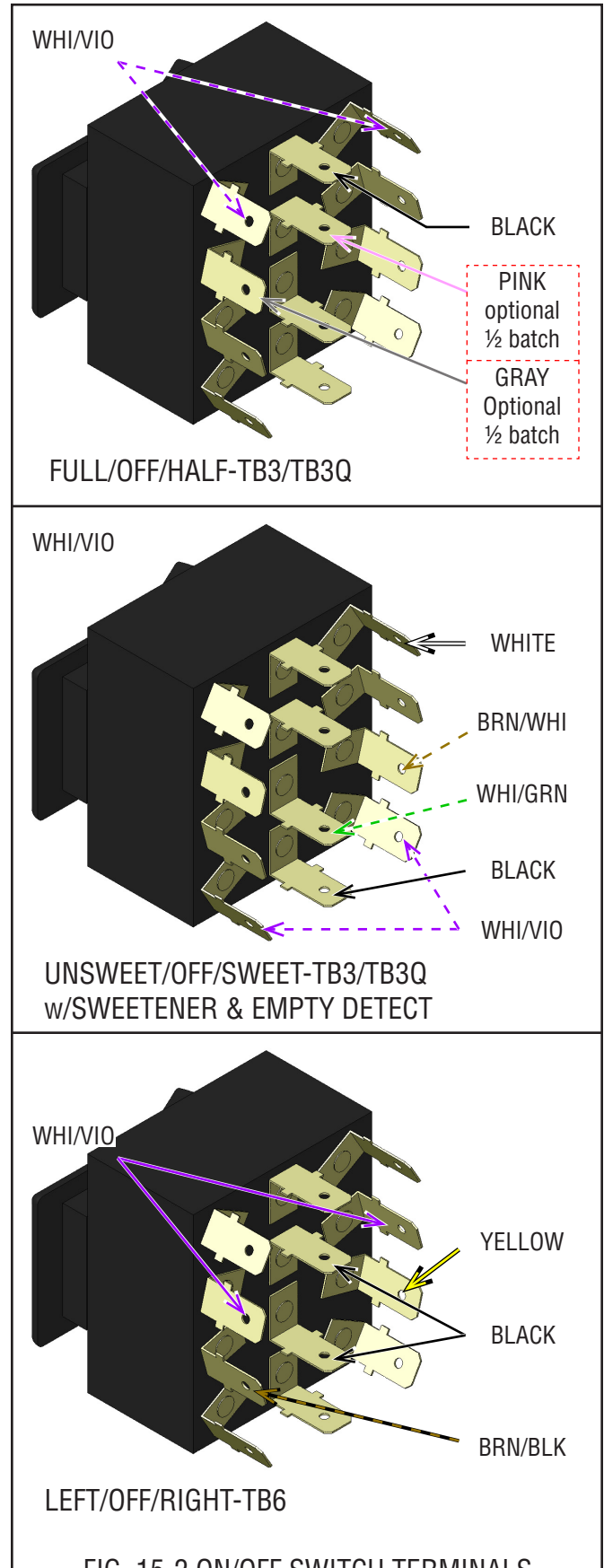

FIG. 15-2 ON/OFF SWITCH TERMINALS

**SERVICE (cont.)**  
**START SWITCHES**

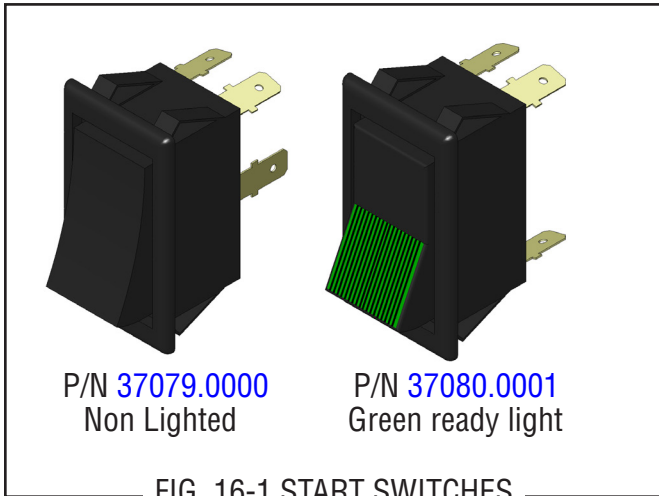

FIG. 16-1 START SWITCHES

**Location:**

The start switch is located in the front of the hood, above and to the right of the brew funnel.

**Test Procedure:**

1. Disconnect the brewer from the power source.
2. Remove the wires from all four terminals.
3. Check for continuity across the two terminals on the right side of the switch when it is held in the lower position. Continuity must not be present across these terminals in the upper position.
4. Check for continuity across the two terminals on the left side of the switch when it is held in the lower position. Continuity must not be present across these terminals in the upper position.

If continuity is not present as described, replace the switch.

If continuity is present as described, reconnect the wires, the switch is operating properly.

If continuity is not present as described, replace the switch.

**NOTE:** No continuity will show across the left terminals of the lighted switch since the light is neon.

**Removal and Replacement:**

1. Remove the wires from the switch terminals.
2. Compress the clips inside the hood and gently push the switch through the opening.
3. Push the new switch into the opening and spread the clips to hold the switch captive in the hood.
4. Refer to Fig. 16-2 when reconnecting the wires.

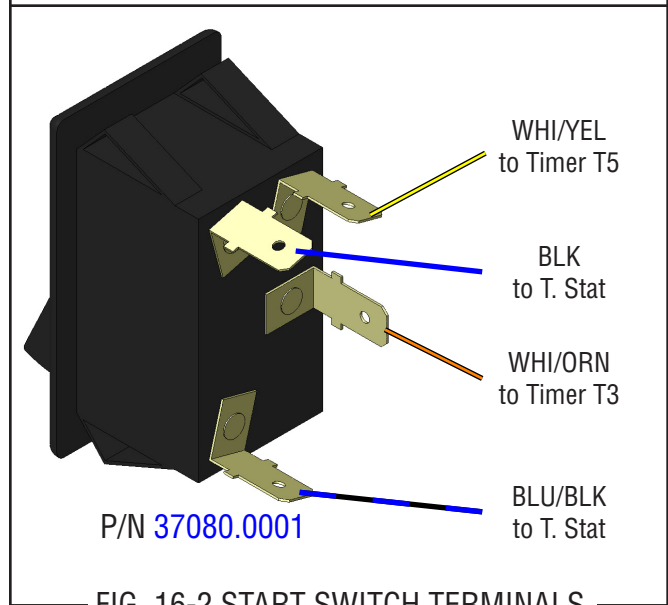
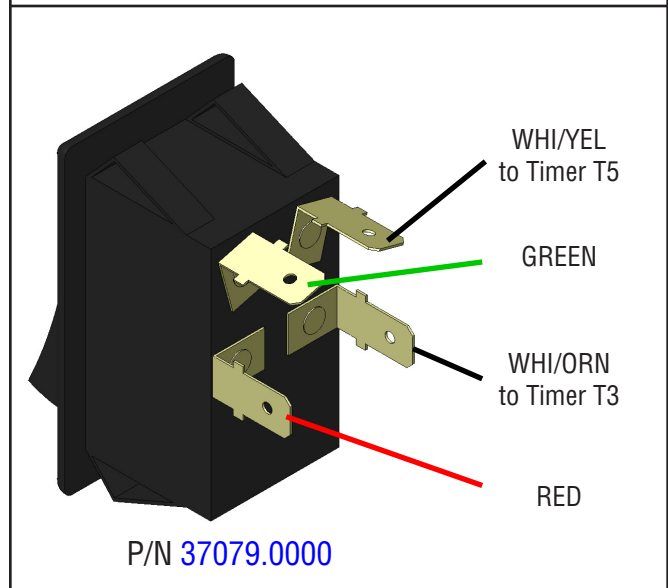
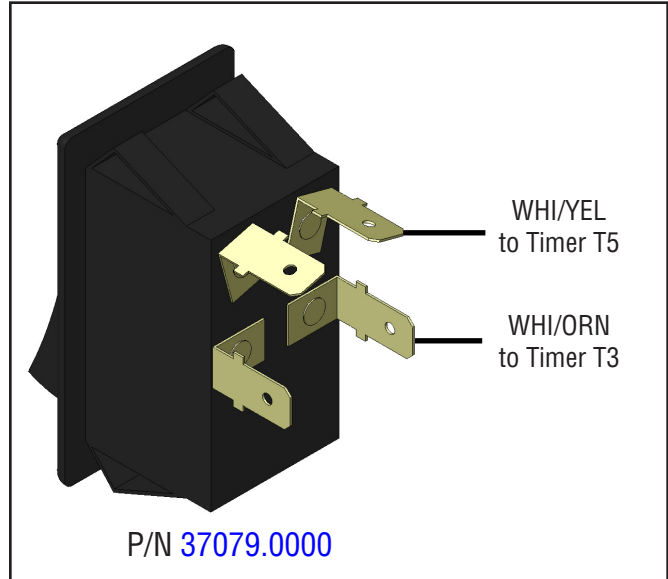

FIG. 16-2 START SWITCH TERMINALS



## SERVICE (cont.)

### BREW/DILUTION TIMER (TB3 & TB6)

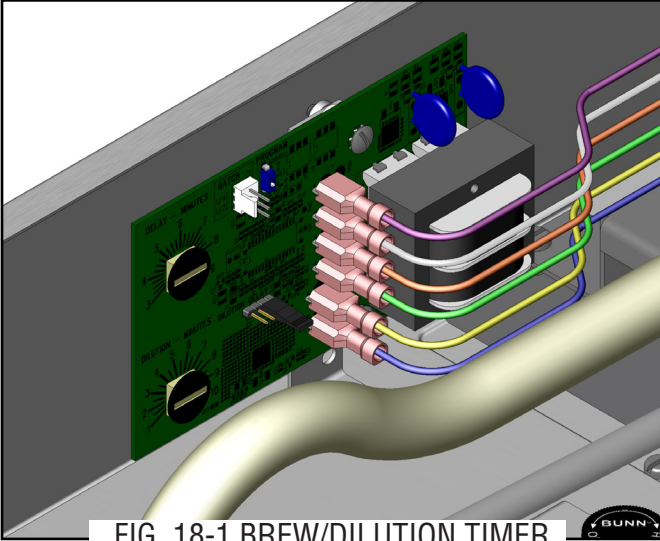

FIG. 18-1 BREW/DILUTION TIMER

#### Location:

The timer is located in left side of the hood.

#### Test Procedure:

**NOTE:** Do not remove or install wires while timer board is installed. *Pressure applied to one side may cause damage to the board.*

1. Disconnect the brewer from the power source and remove the top cover.
2. With a voltmeter, check the supply voltage across terminals TL1 and TL2. Connect the brewer to the power source. Turn on the "ON/OFF" switch. The voltage must be:
  - a) 120 volts ac for two wire 120 volt models.
  - b) 200 to 230 volts ac on two wire 200 volt or 230 volt models.
3. Disconnect the brewer from the power source.

If voltage is present as described, proceed to #4.

If voltage is not present as described, refer to the *Wiring Diagrams* and check the wiring harness.

4. With a voltmeter, check the BREW output voltage across terminals TL2 and TL4; and the DILUTION output voltage across terminals TL2 and TL6. Connect the brewer to the power source, turn on the "ON/OFF" switch and press the "START" switch. The voltage must be:
  - a) 120 volts ac for two wire 120 volt models.
  - b) 200 to 230 volts ac for two wire 200 volt or 230 volt models.

If voltage is present as described, the timer is operating properly.

If voltage is not present as described, disconnect the brewer from the power source and replace the timer.

#### Removal and Replacement:

1. Remove the two #6-32 screws, lock washers and spacers securing timer to bracket.
2. Disconnect all wires from the timer.
3. Refer to schematic and reconnect wires.
4. Install new timer to bracket with the two #6-32 screws, lock washers and spacers.
5. Adjust the timer as required.

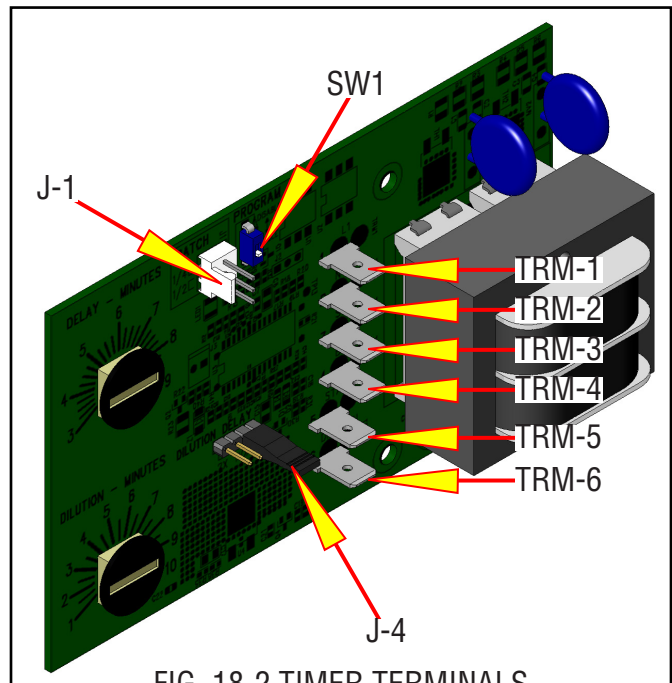

FIG. 18-2 TIMER TERMINALS

#### Terminals:

- |       |                                            |
|-------|--------------------------------------------|
| J-1   | ½ batch connector                          |
| J-4   | Dilution delay time 1-2 (NORMAL), 3-4 (2x) |
| SW-1  | Programming Enable/Disable                 |
| TRM-1 | White/Violet L1 in from ON/OFF switch      |
| TRM-2 | White (Red) Neutral (L2)                   |
| TRM-3 | White/Orange Start switch                  |
| TRM-4 | White/Green Brew solenoid                  |
| TRM-5 | White/Yellow Start switch                  |
| TRM-6 | White/Blue Dilution solenoids              |

**SERVICE (cont.)**

**BREW/DILUTION TIMER (TB3 & TB6) (cont.)**

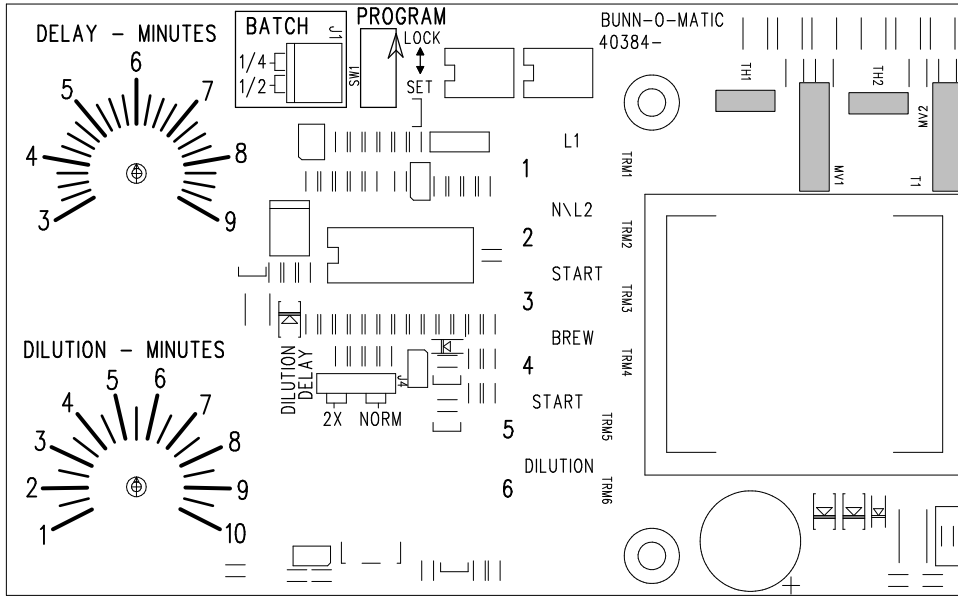

**FIG. 19-1 BREW/DILUTION TIMER TRIACS**

Triacs:

- TH-1/MV-1 Brew solenoid
- TH-2/MV-2 Dilution solenoid

## SERVICE (cont.)

### DIGITAL BREW TIMER (TB3Q & TB6Q)

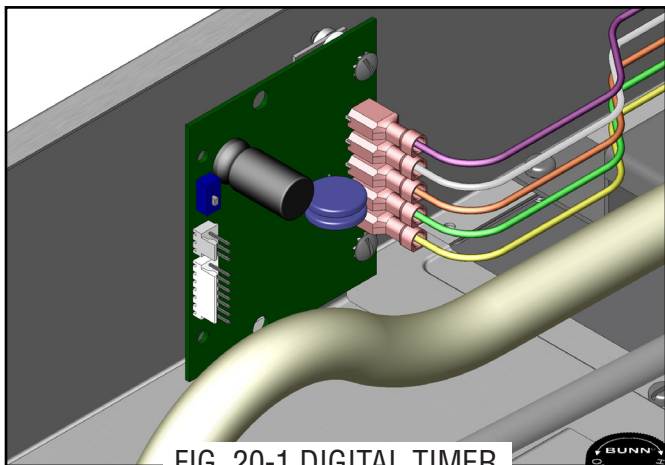

FIG. 20-1 DIGITAL TIMER

#### Location:

The timer is located in left side of the hood.

#### Test Procedure

**NOTE:** Do not remove or install wires while timer board is installed. Pressure applied to one side may cause damage to the board.

1. Disconnect the brewer from the power source and remove the top cover.
2. With a voltmeter, check the supply voltage across terminals TL1 and TL2. Connect the brewer to the power source. Turn on the "ON/OFF" switch. The voltage must be:
  - a) 120 volts ac for two wire 120 volt models.
  - b) 200 to 230 volts ac on two wire 200 volt or 230 volt models.
3. Disconnect the brewer from the power source.

If voltage is present as described, proceed to #4.

If voltage is not present as described, refer to the *Wiring Diagrams* and check the wiring harness.

4. With a voltmeter, check the output voltage across terminals TL1 and TL4. Connect the brewer to the power source, turn on the "ON/OFF" switch and press the "START" switch. The voltage must be:
  - a) 120 volts ac for two wire 120 volt models.
  - b) 200 to 230 volts ac for two wire 200 volt or 230 volt models.

If voltage is present as described, the timer is operating properly. If voltage is not present as described, proceed to #5.

5. With a voltmeter, check the input start voltage across terminals TL2 and TL5. Connect the brewer

to the power source, turn on the "ON/OFF" switch and press the "START" switch. The indication must be as follows:

- a) 120 volts ac for two wire 120 volt models.
- b) 200 to 230 volts ac on two wire 200 volt or 230 volt models.

If voltage is not present as described, refer to the *Wiring Diagrams* and check the wiring harness to the start switch.

If start voltage is present as described (but no output voltage), replace the timer.

#### Removal and Replacement:

1. Remove the two #6-32 screws, lock washers and spacers securing timer to bracket.
2. Disconnect all wires from the timer.
3. Refer to schematic and reconnect wires.
4. Install new timer to bracket with the two #6-32 screws, lock washers and spacers.
5. Adjust the timer as required.

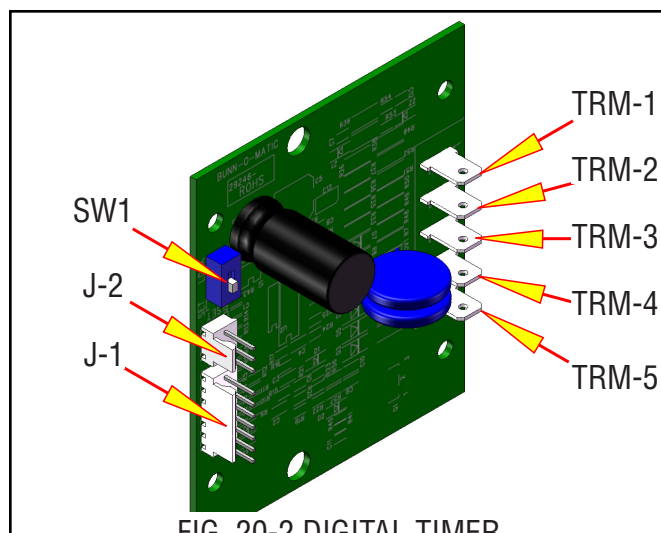

FIG. 20-2 DIGITAL TIMER

#### Terminals:

- |       |                                     |
|-------|-------------------------------------|
| J-2   | 1/2 batch connector                 |
| J-1   | Multi batch (NOT USED IN TB SERIES) |
| SW-1  | Programming Enable/Disable          |
| TRM-1 | White/Violet L1 from ON/OFF switch  |
| TRM-2 | White (Red) Neutral (L2)            |
| TRM-3 | White/Orange Start switch           |
| TRM-4 | White/Green Brew solenoid           |
| TRM-5 | White/Yellow Start switch           |

**SERVICE (cont.)**

**DIGITAL BREW TIMER (TB3Q & TB6Q) (cont.)**

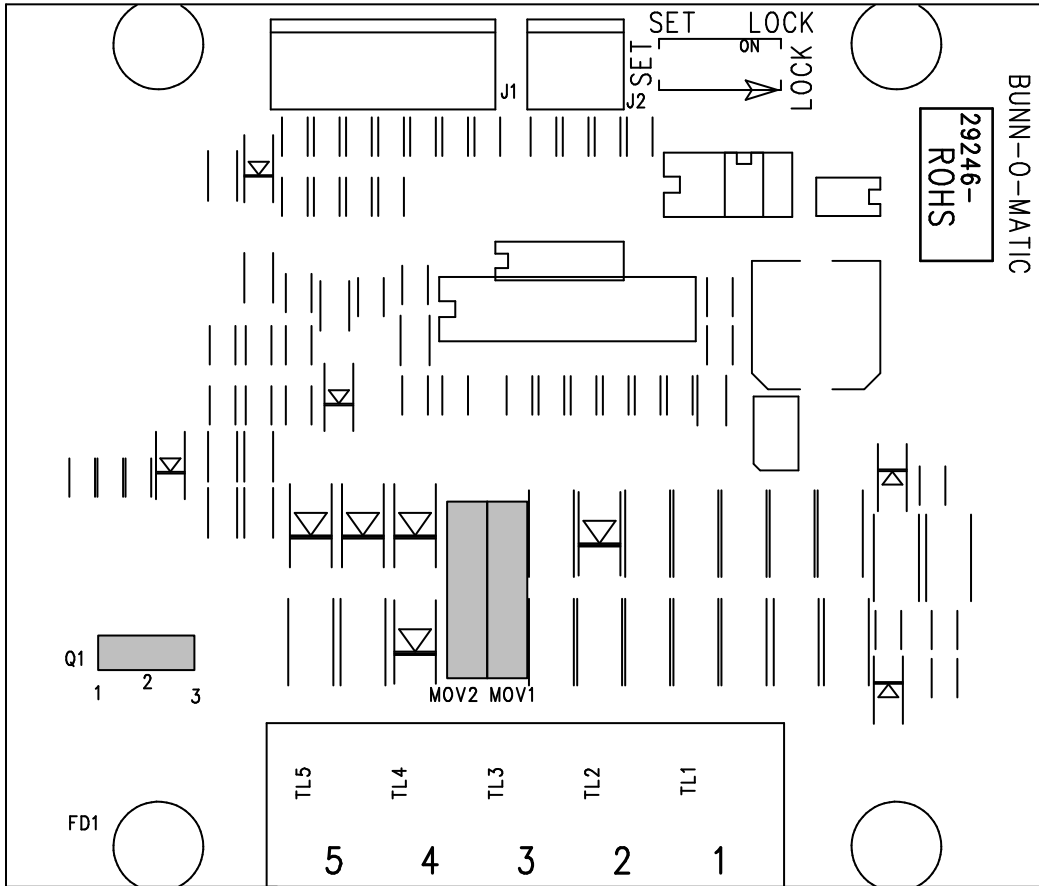

FIG. 21-1 DIGITAL TIMER TRIACS

Triacs:

Q-1/MV-2 Brew solenoid output

MV-1 Line in

# SCHEMATIC WIRING DIAGRAM TB3Q

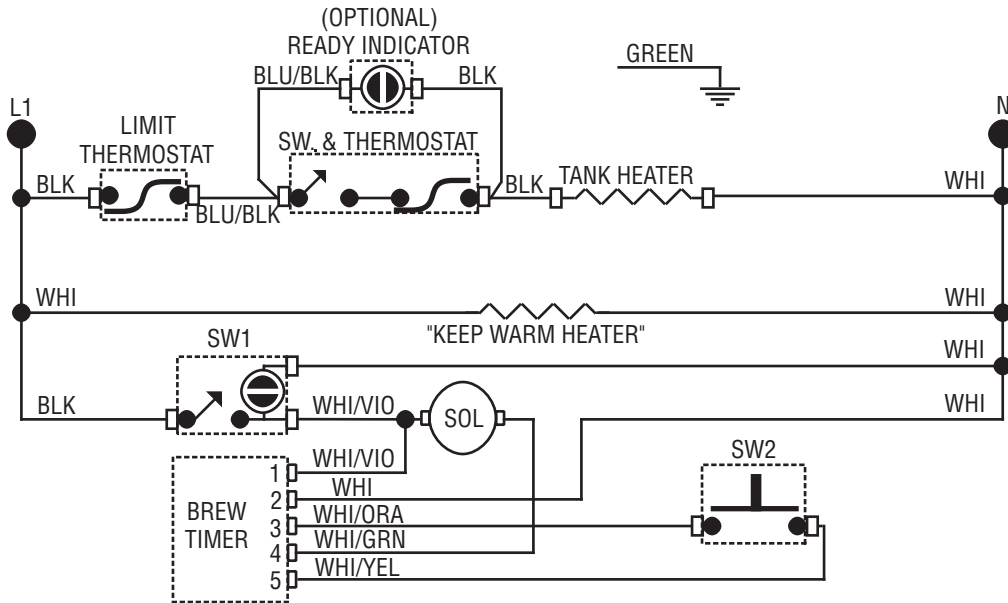

**120 VOLTS AC  
2 WIRE  
SINGLE PHASE**

37234.0001A 08/04 © 2004 BUNN-O-MATIC CORPORATION

# SCHEMATIC WIRING DIAGRAM TB3QA

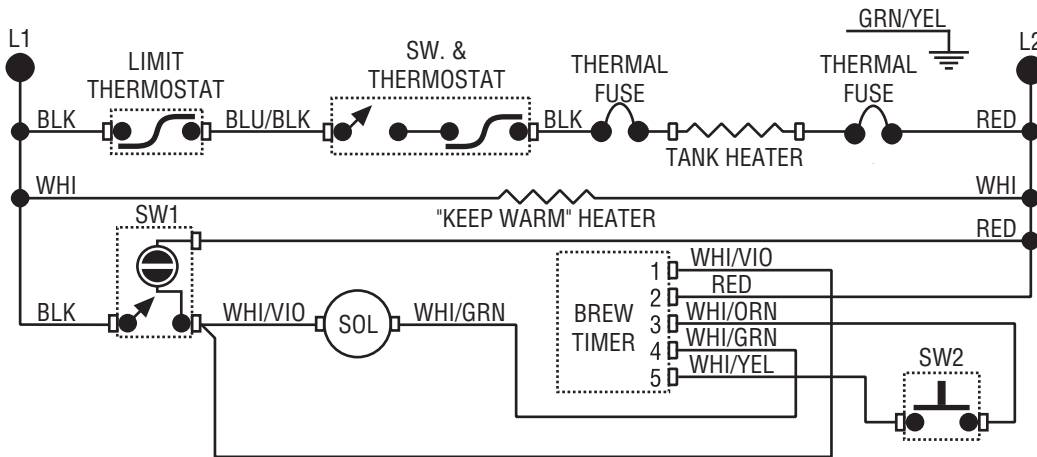

**230 VOLTS AC  
2 WIRE  
SINGLE PHASE**

37234.0003A 11/04 © 2004 BUNN-O-MATIC CORPORATION

# SCHEMATIC WIRING DIAGRAM TB3, TB3B, TB3-LP

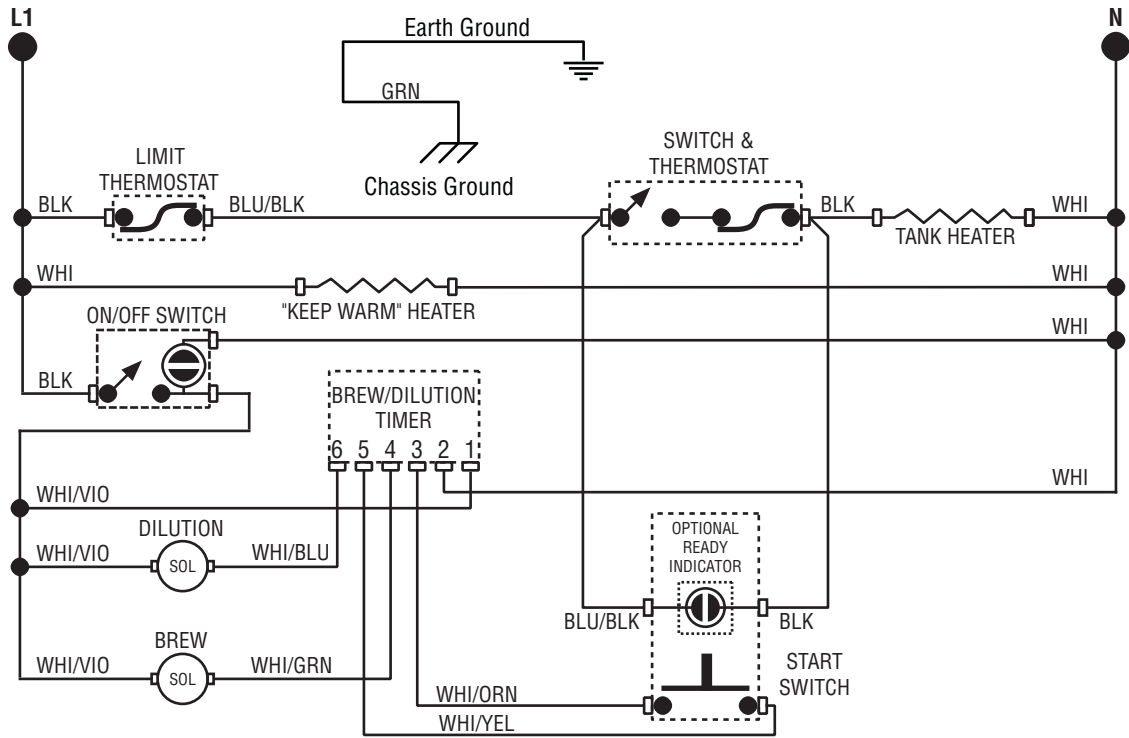

**100 VOLTS AC**  
**120 VOLTS AC**  
**2 WIRE + GND**  
**SINGLE PHASE**

37234.0007A 02/08 © 2008 BUNN-O-MATIC CORPORATION

# SCHEMATIC WIRING DIAGRAM TB3B W/HALF-BATCH

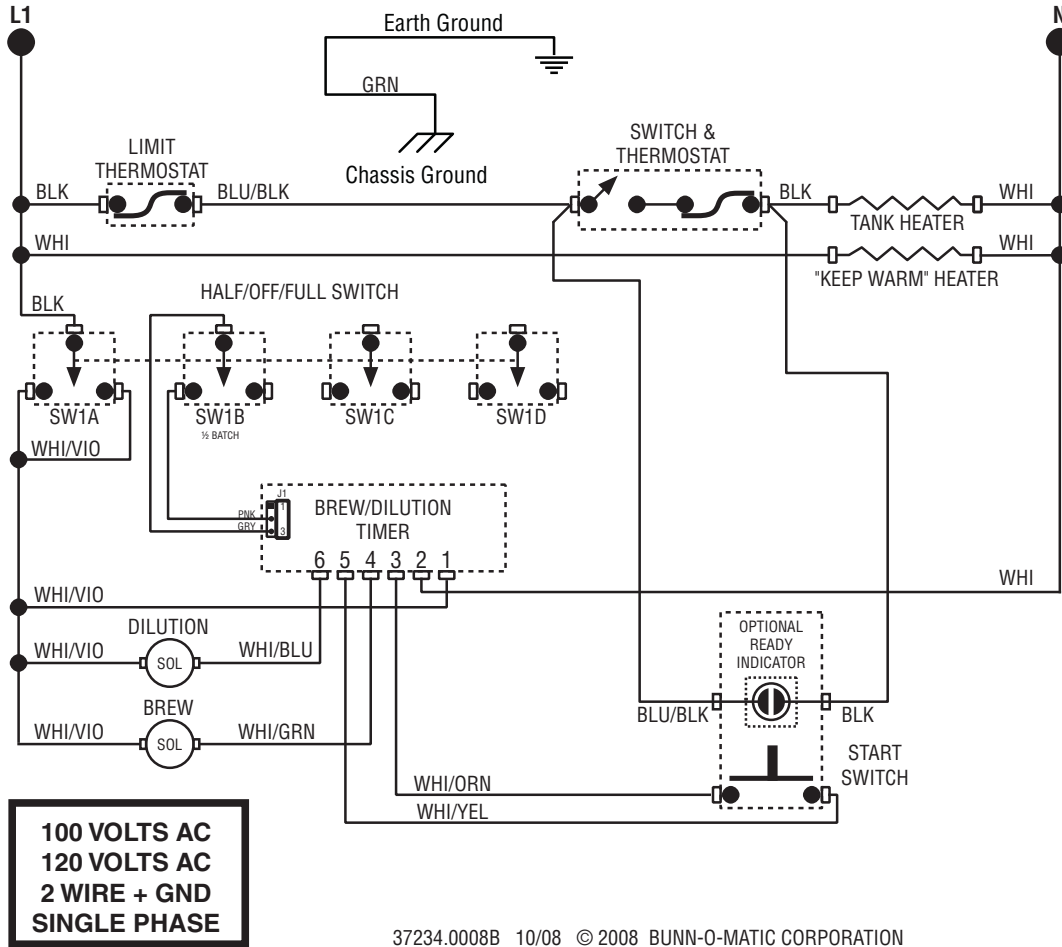

# SCHEMATIC WIRING DIAGRAM TB3Q

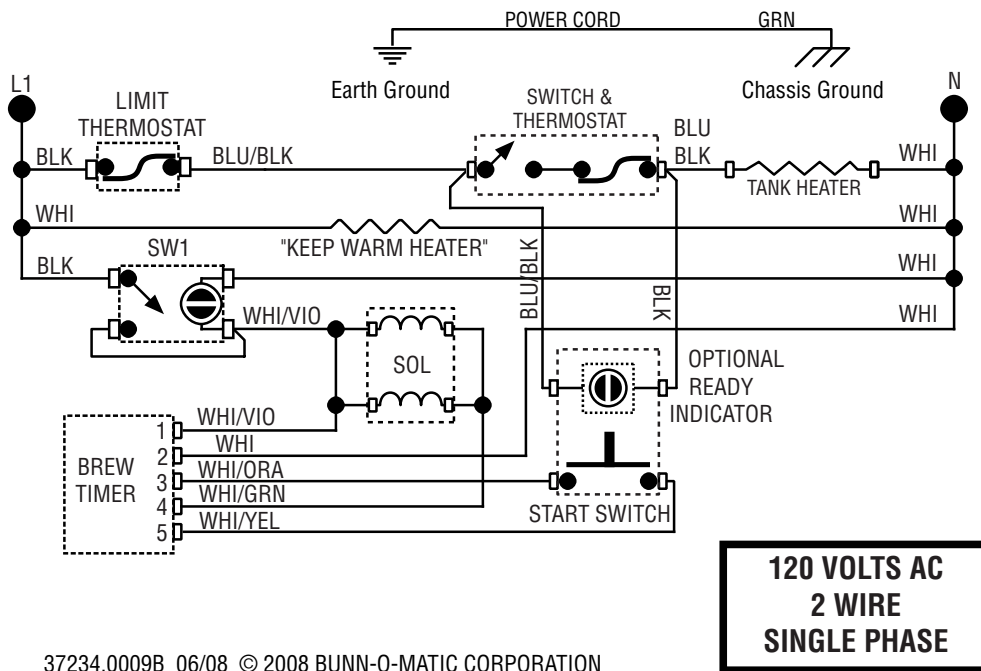

# SCHEMATIC WIRING DIAGRAM TB3Q W/SWEETENER & EMPTY BAG DETECT

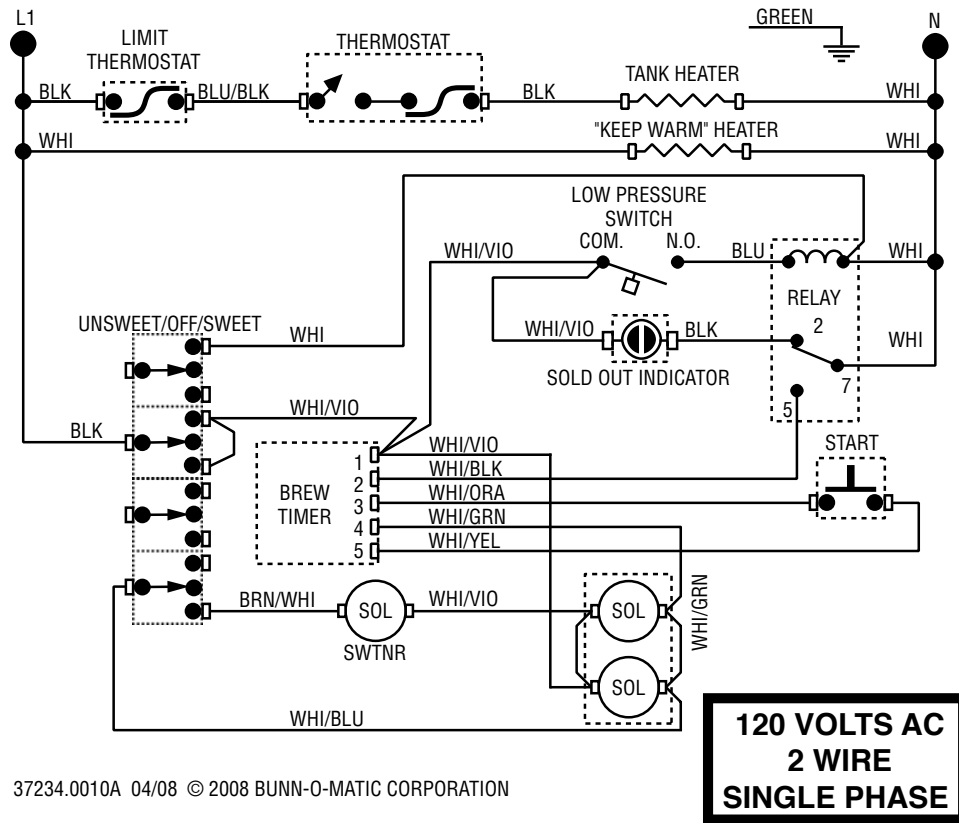

37234.0010A 04/08 © 2008 BUNN-O-MATIC CORPORATION

# SCHEMATIC WIRING DIAGRAM TB3A

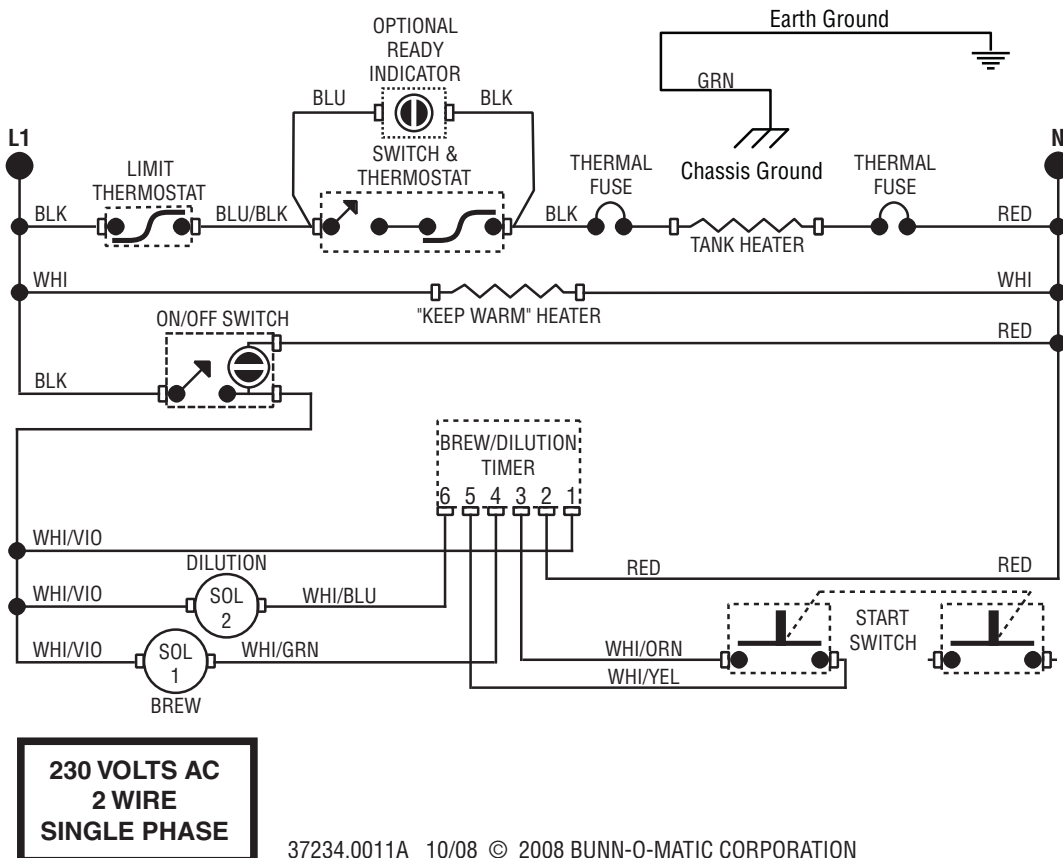

37234.0011A 10/08 © 2008 BUNN-O-MATIC CORPORATION

# SCHEMATIC WIRING DIAGRAM TB6

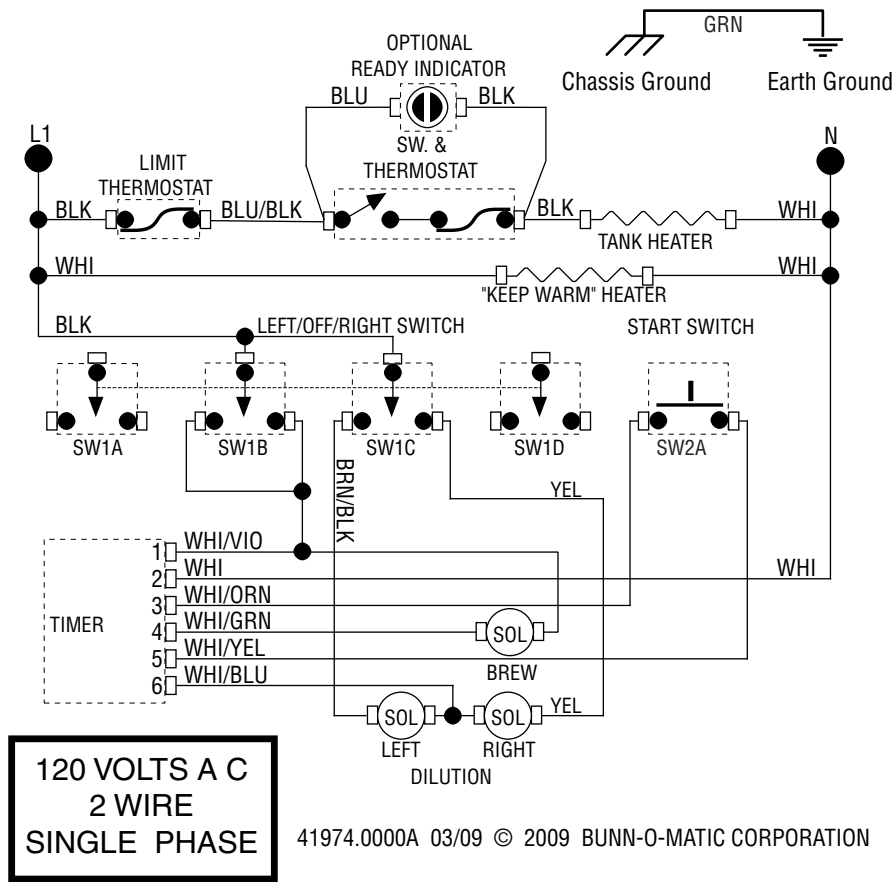

# SCHEMATIC WIRING DIAGRAM TB6Q

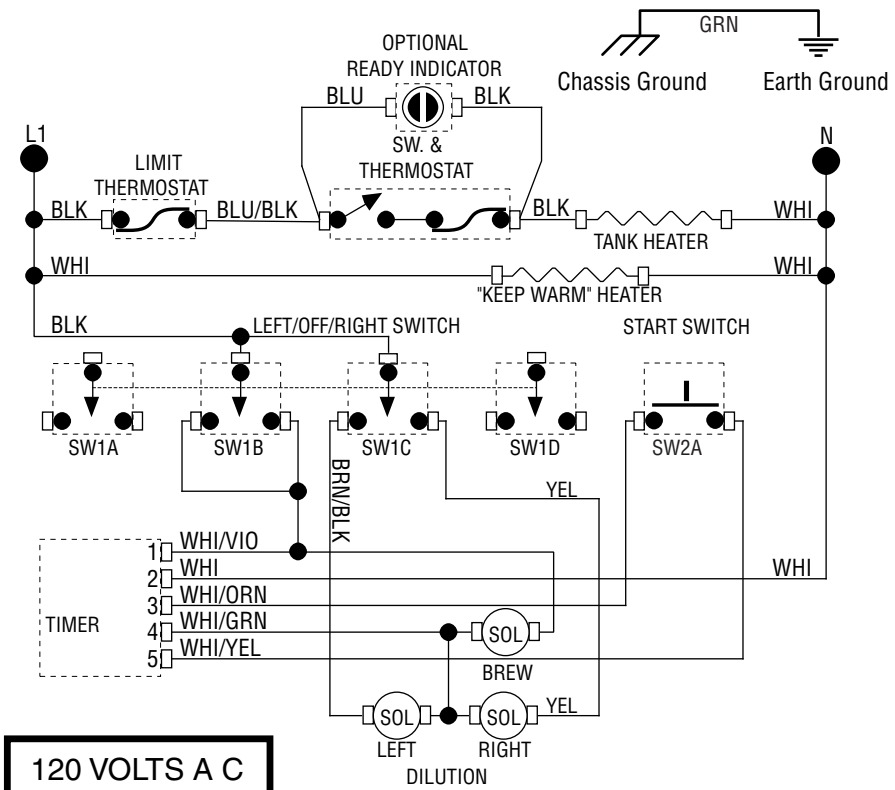

**120 VOLTS A C  
2 WIRE  
SINGLE PHASE**

41975.0000A 03/09 © 2009 BUNN-O-MATIC CORPORATION