



SERVICE & REPAIR MANUAL

Bunn-O-Matic Corporation
Post Office Box 3227, Springfield, Illinois 62708-3227
Phone (217) 529-6601 | Fax (217) 529-6644

BUNN-O-MATIC COMMERCIAL PRODUCT WARRANTY

Bunn-O-Matic Corp. ("BUNN") warrants equipment manufactured by it as follows:

- 1) All coffee and tea dispensers/servers, MCR/MCP/MCA single cup brewers, and BUNNlink® electronic circuit and/or control boards – 1 year parts and 1 year labor.
- 2) Product-specific warranties for Crescendo®, Fast Cup®, Sure Immersion®, Sure Tamp®, and others – 1 year parts and 1 year labor. Please visit commercial.bunn.com/support/warranty-lookup for further details.
- 3) All other equipment – 2 years parts and 1 year labor plus added warranties as specified below:
 - a) Electronic circuit and/or control boards – parts and labor for 3 years.
 - b) Compressors on refrigeration equipment – 5 years parts and 1 year labor.
 - c) Grinding burrs on coffee grinding equipment for 4 years or 40,000 pounds of coffee, whichever comes first.

These warranty periods run from the date of installation. BUNN warrants that the equipment manufactured by it will be commercially free of defects in material and workmanship existing at the time of manufacture and appearing within the applicable warranty period. This warranty does not apply to any equipment, component or part that was not manufactured by BUNN or that, in BUNN's judgment, has been affected by misuse, neglect, alteration, improper installation or operation, improper maintenance or repair, non periodic cleaning and descaling, equipment failures related to poor water quality, damage or casualty. In addition, the warranty does not apply to replacement of items subject to normal wear with use including but not limited to user replaceable parts such as seals and gaskets. This warranty is conditioned on the Buyer 1) giving BUNN prompt notice of any claim to be made under this warranty by telephone at (217) 529-6601 or by writing to Post Office Box 3227, Springfield, Illinois 62708-3227; 2) if requested by BUNN, shipping the defective equipment prepaid to an authorized BUNN service location; and 3) receiving prior authorization from BUNN that the defective equipment is under warranty.

THE FOREGOING WARRANTY IS EXCLUSIVE AND IS IN LIEU OF ANY OTHER WARRANTY, WRITTEN OR ORAL, EXPRESS OR IMPLIED, INCLUDING, BUT NOT LIMITED TO, ANY IMPLIED WARRANTY OF EITHER MERCHANTABILITY OR FITNESS FOR A PARTICULAR PURPOSE. The agents, dealers or employees of BUNN are not authorized to make modifications to this warranty or to make additional warranties that are binding on BUNN. Accordingly, statements by such individuals, whether oral or written, do not constitute warranties and should not be relied upon.

If BUNN determines in its sole discretion that the equipment does not conform to the warranty, BUNN, at its exclusive option while the equipment is under warranty, shall either 1) provide at no charge replacement parts and/or labor (during the applicable parts and labor warranty periods specified above) to repair the defective components, provided that this repair is done by a BUNN Authorized Service Representative; or 2) shall replace the equipment or refund the purchase price for the equipment.

THE BUYER'S REMEDY AGAINST BUNN FOR THE BREACH OF ANY OBLIGATION ARISING OUT OF THE SALE OF THIS EQUIPMENT, WHETHER DERIVED FROM WARRANTY OR OTHERWISE, SHALL BE LIMITED, AT BUNN'S SOLE OPTION AS SPECIFIED HEREIN, TO REPAIR, REPLACEMENT OR REFUND.

In no event shall BUNN be liable for any other damage or loss, including, but not limited to, lost profits, lost sales, loss of use of equipment, claims of Buyer's customers, cost of capital, cost of down time, cost of substitute equipment, facilities or services, or any other special, incidental or consequential damages.

CONTENTS

Equipment Notices & Safeguards.....	4
Operating Controls	5
Software Program Informational Screens.....	7
Product Instructions.....	8
Brix Pump/Autofill Set-Up Diagram.....	9
CFV/Autofill Set-Up Diagram	10
Preventive Maintenance	11
Troubleshooting	15
Fault Messages	24
Equipment Service Panels	27
Service - Front Panel Components.....	28
Control & Autofill Board.....	28
Membrane Switch	29
Service - Hopper Lid Assembly	31
Service - Rear Cover Components.....	32
Mag Contact Assembly	32
Left & Right Auger Motor.....	33
Left and Right Auger Motor Capacitor.....	35
Left & Right Torque Sensor Board.....	36
Left & Right PTC Heater	38
Left & Right Cooling Drum Temperature Sensor.....	40
CF CFIVE Solenoid Valves - CFV/Autofill	41
Left & Right Pressure Switch - CFV/Autofill	43
CF CFIVE Solenoid Valves - LAF/Autofill	44
Left & Right Refrigerant Solenoids.....	46
Left & Right Auger Shaft Assembly.....	47
Service - Left Side Panel Components.....	49
Refrigeration Hot Gas Temperature Sensor.....	49
Condenser Fan Assembly	50
Service - Right Side Panel Components	51
Compressor Relay	51
Power Supply	52
R-290 Compressor Hazard Classification & Safeguards	54
R-290 Compressor.....	55
R-290 Compressor Start & Run Capacitor.....	57
R-290 Compressor Start Relay.....	60
R290 Compressor Relay, Start & Run Wiring and Coolant Diagram	61
Control Board Triac Diagram and Control Board Input & Output Chart	63
Ultra® NX Wiring Schematic	66


EQUIPMENT NOTICES & SAFEGUARDS

User Notices

Carefully read and follow all notices on the equipment and in this manual. They were written for your protection. All notices are to be kept in good condition. Replace any unreadable or damaged labels.

⚠ WARNING	
Risk Of Electric Shock <ul style="list-style-type: none">• Use only on a properly protected circuit capable of the rated load.• Electrically ground the chassis.• Follow national/local electrical codes.• Do not use near combustibles.• Do not deform plug or cord.	Moving Parts <ul style="list-style-type: none">• Do not operate unit with this panel removed.• Disconnect power before servicing unit.
• READ THE ENTIRE OPERATING MANUAL BEFORE USING THIS PRODUCT	
• FAILURE TO COMPLY RISKS EQUIPMENT DAMAGE, FIRE OR SHOCK HAZARD.	

57864.0000

⚠ CAUTION	
 Propane (R-290)	Risk Of Fire Or Explosion. <ul style="list-style-type: none">• Flammable Refrigerant Used. • Consult Instruction Manual/Repair Manual/Owner's Guide Before Attempting To Install Or Service This Product. • All Safety Precautions Must Be Followed. • Dispose Of Properly in Accordance With Federal Or Local Regulations. • Do Not Puncture Refrigerant Tubing. • Follow Handling Instructions Carefully.


57863.0000

⚠ DANGER	
 Propane (R-290)	Risk Of Fire Or Explosion. <ul style="list-style-type: none">• Flammable Refrigerant Used.• To Be Repaired By R-290 Trained Service Personnel.• Do Not Puncture Refrigerant Tubing.• Do Not Braze Pressurized Vessel.

57862.0000

CHARGE	
Type R290, Amount 4.16 oz (118 gm)	
Design Pressures: GWP=3	
High 430 psi (29.6 bar) (2.96 MPa)	
Low 80 psi (5.5 bar) (0.55 MPa)	

29373.0005

CHARGE	
 Propane (R-290)	Type R290, Amount 4.0 oz (114 gm)
	Design Pressures: GWP=3
	High 430 psi (29.6 bar) (2.96 MPa)
	Low 80 psi (5.5 bar) (0.55 MPa)

29373.0006
(220 - 240V)

INTENDED FOR USE AT A ROOM TEMPERATURE OF	
80°F (27°C)	

29979.0000



WARNING: Equipment contains a highly flammable refrigerant.

ULTRA NX Placement Requirements

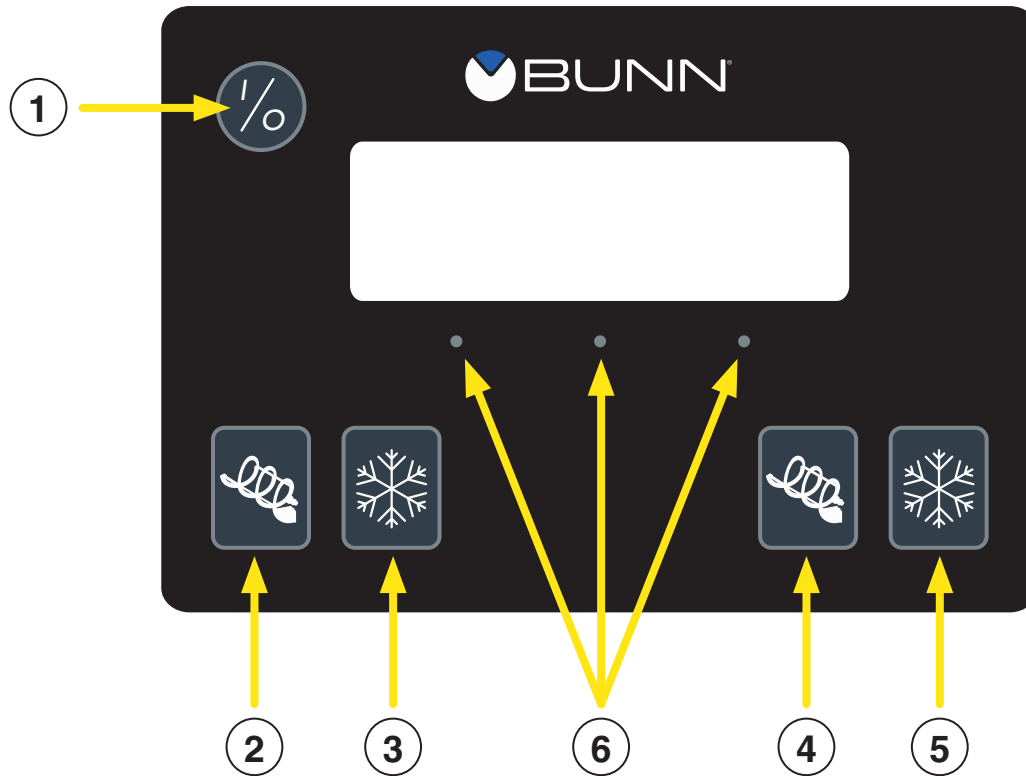
- Counter or table capable of supporting at least 180 lbs.
- Indoor use only.
- Ultra NX must have at least six inches of space behind it. The space is needed for airflow, air filter removal, and cleaning.
- A clearance of at approximately six inches is recommended between the dispenser sides and the wall or another appliance.
- The Ultra NX performs better if not placed near any heating appliance or other appliance blowing hot air directly onto Ultra NX.

ULTRA NX Important Service Safeguards

- Always disconnect power source to the dispenser before servicing inside.
- When performing service inside the dispenser and power is required for troubleshooting purposes, the condenser fan will turn on every 30 minutes to aid cooling the entire unit. Keep Hands Away From Fan!
- Trained service personnel with the knowledge of servicing and troubleshooting R-290 refrigeration systems or related components should be used.
- All components used in Ultra NX are rated for refrigerant R-290 application.
- Always wear and use the appropriate safety gear when servicing electrical and refrigeration systems. Protective gloves, eye wear, shoes, clothes and tools.
- In order to maintain proper machine operation, regular maintenance intervals are required.

OPERATING CONTROLS

There are five of these switches that will be used for the operation of the dispenser.



1. Switch - Upper left corner of the control pad:

This switch is the ON/OFF toggle switch which powers up the dispenser and the LCD display. When ON the Date and Time toggle back and forth continuously except during programming.



2. Bottom left corner:

This is used to turn the left side auger motor to AUGER ON, AUGER OFF or AUGER REFILL ON. (Refill only applicable when installed)



3. Bottom left corner:

This is used to turn the left side ice control to OFF, ICE, CHILL or DEFROST.



4. Bottom right corner:

This is used to turn the right side auger motor AUGER ON, AUGER OFF or AUGER REFILL ON. (Refill only applicable when installed)



5. Bottom right corner:

This is used to turn the right side ice control to OFF, ICE, CHILL or DEFROST.

• • •

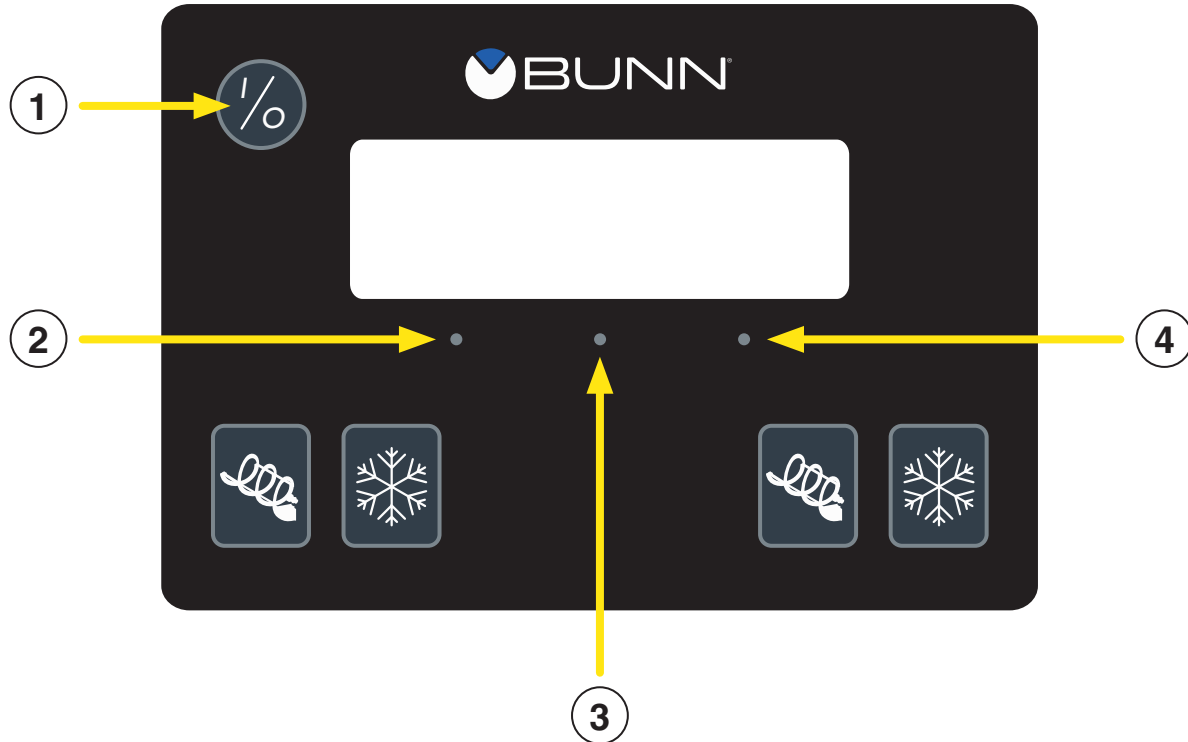
6. Three Dots:

Where hidden buttons are located to use for Programming.

OPERATING CONTROLS

Using the menu-driven display on the front of the dispenser, the operator has the ability to alter or modify various parameters such as beverage consistency and set day/night “ON/OFF” times. The operator is also prompted to check a variety of periodic service functions or even a step-by-step cleaning routine. There is also the opportunity to return all changes back to factory default settings.

Access to most controls can be password protected to allow only qualified personnel to make changes.



Programming Switches

To access the programming mode, and to scroll through the different function screens, hidden programming switches are used. There are three of these switches that will be used for the setup of the dispenser or used for troubleshooting purposes.

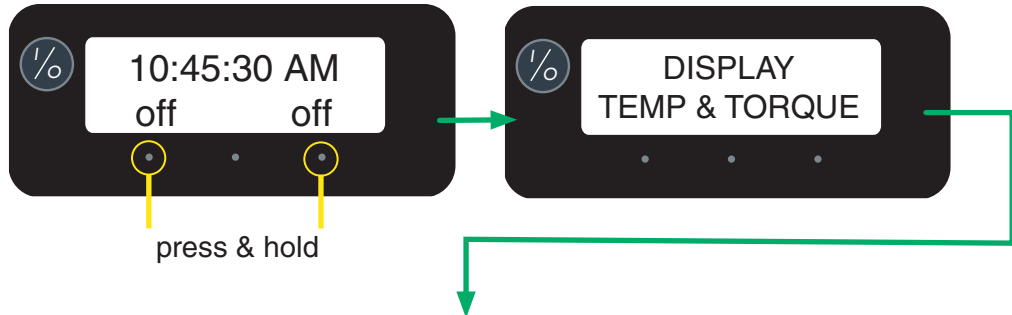
- 1. I/O SWITCH** (upper left corner of the control pad)
This switch is the ON/OFF toggle switch which powers up the dispenser and the LCD display.
This switch is also used as back up switch in menu mode.
- 2. LEFT DOT** (left dot under display)
When prompted by a selection from the menu to answer YES or NO, the Left Dot button is used to answer NO or (-) minus.
- 3. CENTER DOT** (center dot under display)
Press and hold the Center Dot button for 5 seconds to access the Menu Function Index. This switch is also used as NEXT to scroll through the functions.
- 4. RIGHT DOT** (right dot under display)
When prompted by a selection from the menu to answer YES or NO, the Right Dot button is used to answer YES or (+) plus.

SOFTWARE PROGRAM INFORMATIONAL SCREENS

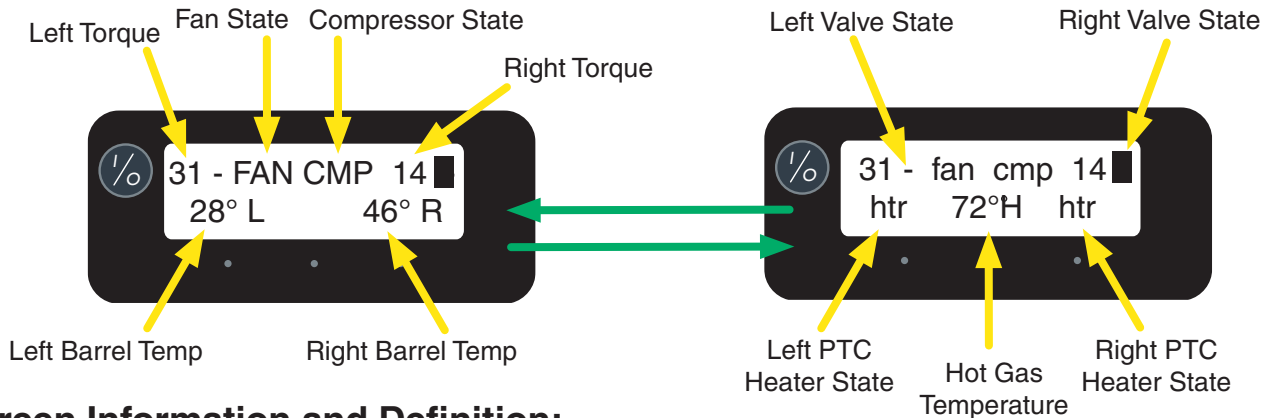
Display Temp and Torque Screens

The TEMP & TORQUE mode is typically used for seeing real time component On/Off operation, product thickness, cooling drum and hot gas temperature for troubleshooting purposes.

Press and hold the left and right hidden buttons for 5 seconds to display the TEMP & TORQUE screen. The temperature of each cooling drum and the hot gas temperature will toggle back and forth. The auger torque is displayed continuously. Press and release the hidden buttons to return to HOME SCREEN.



Example: Informational Screens below will alternate back and forth.



Screen Information and Definition:

Small Block (-): Left or Right Refrigerant Solenoid is OFF

Large Block (■): Left or Right Refrigerant Solenoid is ON

Lower case fan: Means condenser fan is not operating.

Upper case FAN: Means condenser fan is powered and operating.

Lower case cmp: Means compressor is not operating.

Upper case CMP: Means compressor is powered and operating.

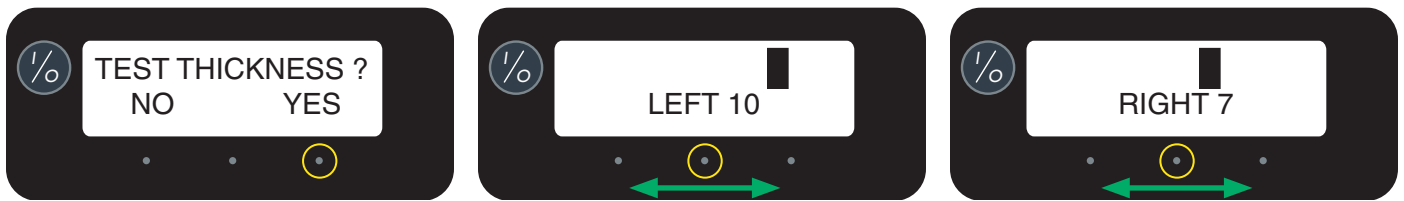
Lower case htr: Means the PTC heater is off.

Upper case HTR: Means the PTC heater is on.

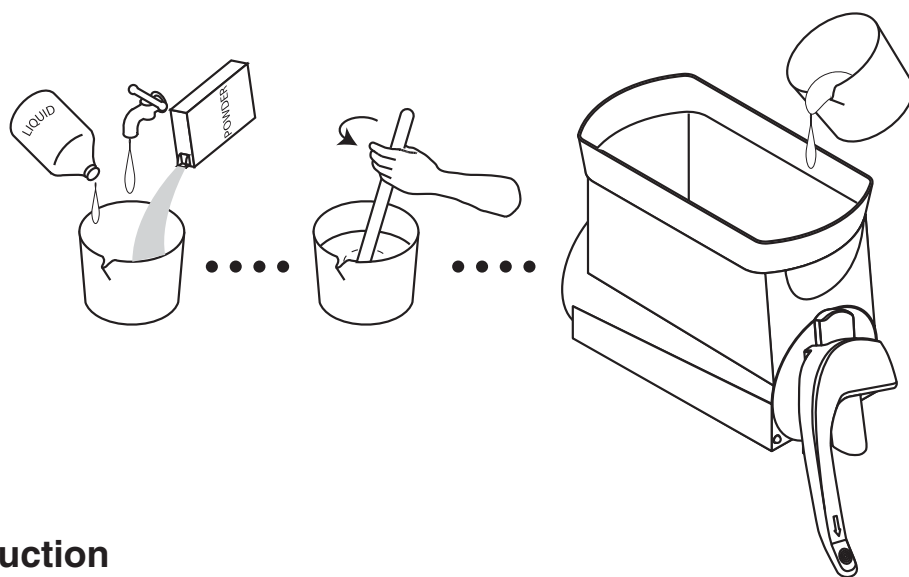
Upper Row Left or Right Number: Means a real time operation number (torque) related to the Daily Operations "Thickness" menu setting which is multiplied by three. Reference "Service Section - Auger Shaft Assembly".

SET THICKNESS

This function adjusts the ice consistency, or torque of each auger when answered YES (Right Dot). Two screens will appear for left and right. The operator can scroll through a range of a minimum of 1 (Center Dot) to a maximum of 16 (Right Dot). Factory default is 7.



PRODUCT INSTRUCTIONS



Product Instruction

- Whether liquid concentrate or granulated powder, all product must be thoroughly mixed BEFORE adding it to the hoppers.
- For best results with granita-type products, use only products with an apparent brix of 12 or higher. Some products may work with an apparent brix as low as 9. Your experimentation with other products will be the best guide in this area. Using products with a brix lower than 12 may cause physical damage to the equipment drive system.
- Keep the pre-mixed liquid product refrigerated. This reduces cooling/freezing time in the dispenser.
- Keep the hoppers topped-off during peak serving periods. Add pre-mixed liquid product as it is dispensed. This reduces the cooling/freezing time and assures you of always having product ready to dispense.
- Keep the product level in the hoppers higher than the auger. If the auger is exposed, air will become entrapped in the mixture resulting in a clouded foamy consistency. This condition could also cause physical damage to the equipment drive system.

Helpful information

- BUNN recommends that the product in the dispenser be thawed each day, usually overnight. The ice granules get too large and a consistent product is difficult to maintain if left frozen for an extended period of time. Set the NIGHT or DEFROST mode for a few hours each night and return to the ICE mode when the product has thawed sufficiently. Refer to Install & Operating manual.
- Some products freeze at a lower temperature than others. You may notice frost or ice on the hoppers. This is normal and should not be a concern.
- Humidity in the air may cause sweating on the outside surfaces of the hoppers. This is to be expected and should not be a concern. The drip trays beneath the hoppers will capture this and cause it to flow to the lower drip tray for disposal.
- Some noises are to be expected during normal operation of the dispenser. By becoming familiar with the noises made during normal operation, you will be better able to listen for problems.
- Any signage attached to the equipment must not be made with PVC, also known as Vinyl or Polyvinyl Chloride.

BRIX PUMP (AUTOFILL) SETUP DIAGRAM

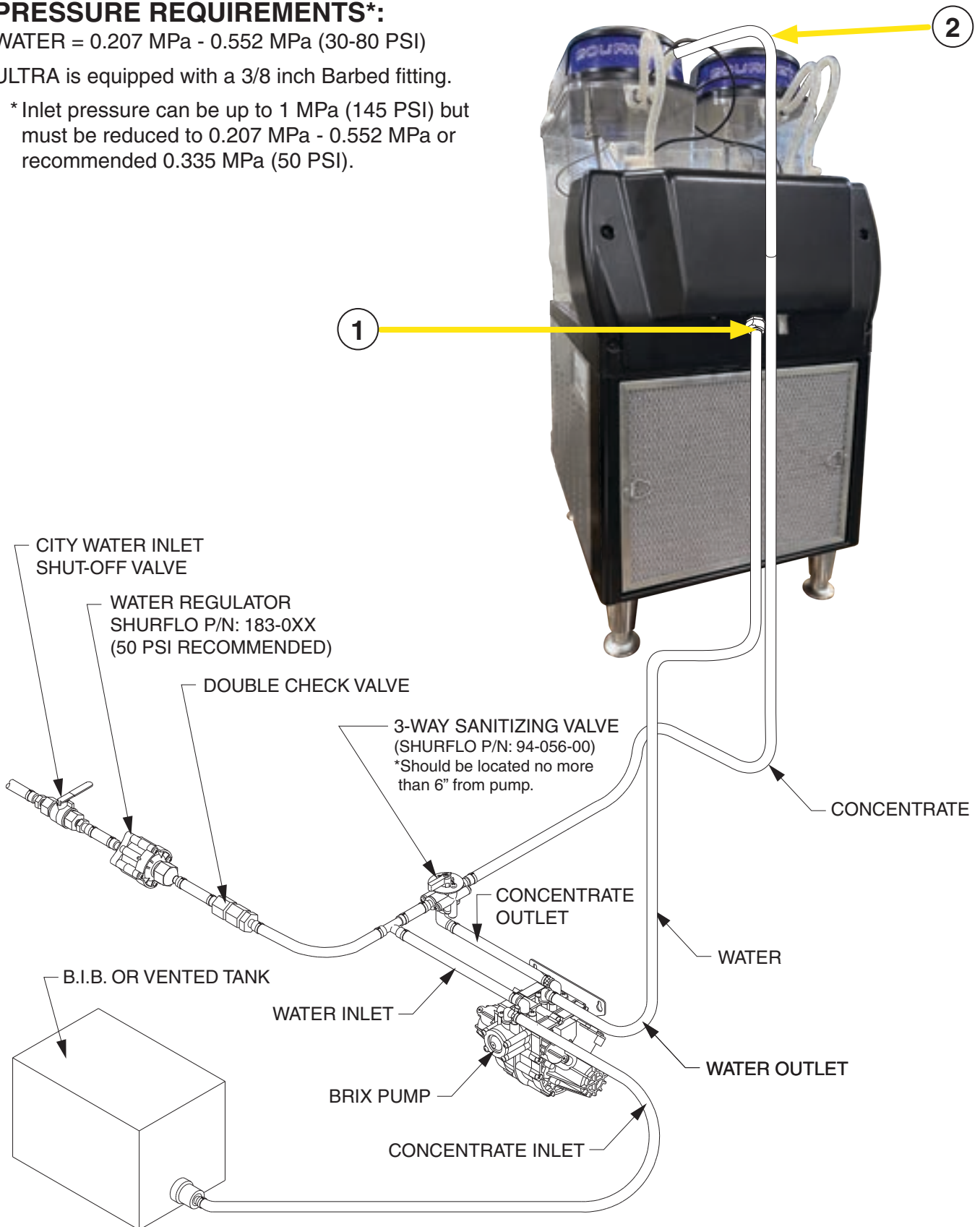
1. Connect the water line to the water fitting in the ULTRA hopper.
2. Connect the concentrate line from the syrup pump to the product fitting in the ULTRA hopper.

PRESSURE REQUIREMENTS*:

WATER = 0.207 MPa - 0.552 MPa (30-80 PSI)

ULTRA is equipped with a 3/8 inch Barbed fitting.

* Inlet pressure can be up to 1 MPa (145 PSI) but must be reduced to 0.207 MPa - 0.552 MPa or recommended 0.335 MPa (50 PSI).



CFV (AUTOFILL) SETUP DIAGRAM

1. Connect the water line to the water fitting in the ULTRA motor cover.
2. Connect the concentrate line from the syrup pump to the product fitting in the ULTRA motor cover.

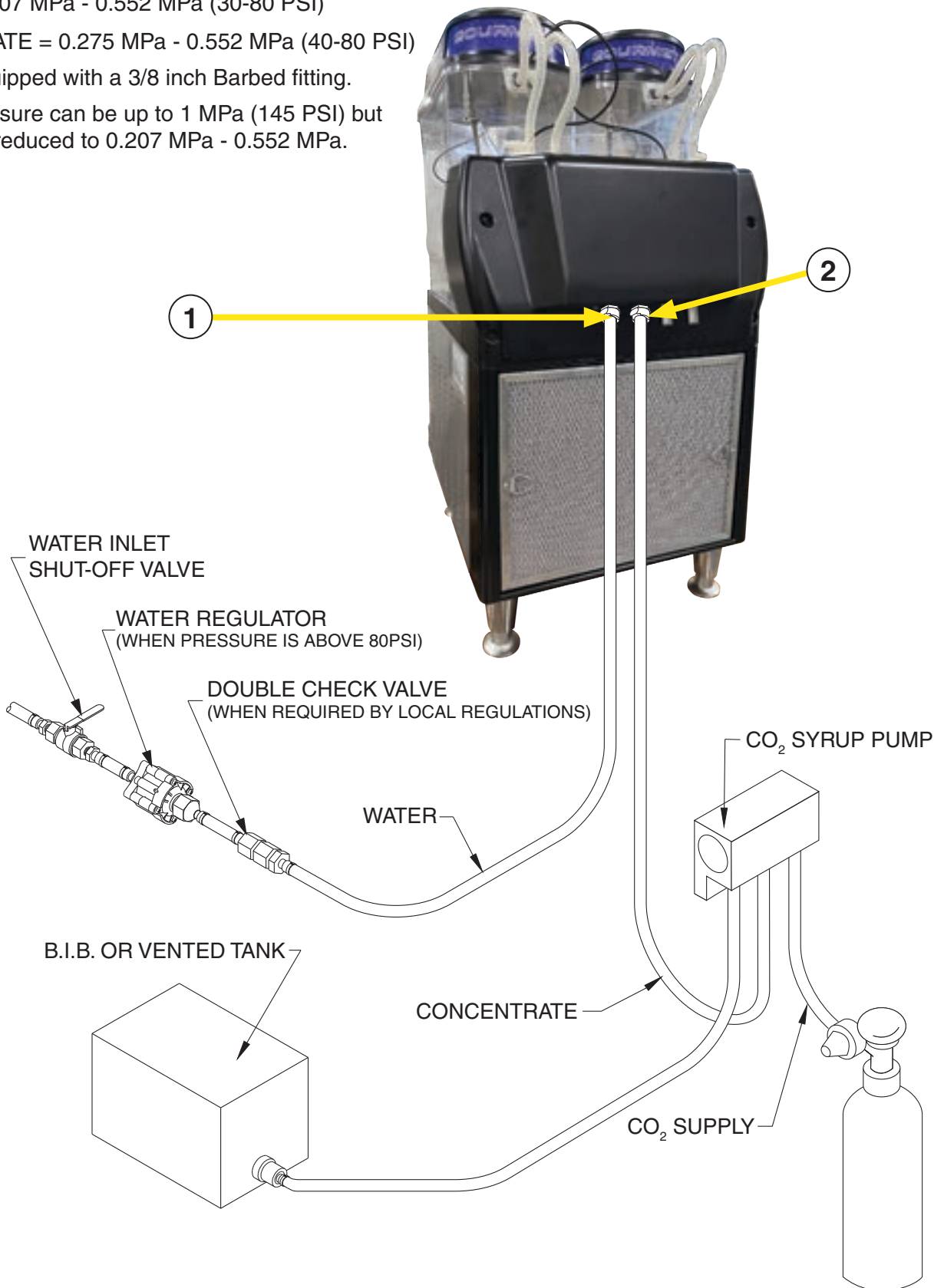
PRESSURE REQUIREMENTS**:

WATER = 0.207 MPa - 0.552 MPa (30-80 PSI)

CONCENTRATE = 0.275 MPa - 0.552 MPa (40-80 PSI)

ULTRA is equipped with a 3/8 inch Barbed fitting.

** Inlet pressure can be up to 1 MPa (145 PSI) but must be reduced to 0.207 MPa - 0.552 MPa.



PREVENTIVE MAINTENANCE

Bunn-O-Matic® Corporation recommends that preventive maintenance be performed at regular intervals. Maintenance should be performed by a qualified service technician.

For Technical Service, contact Bunn-O-Matic Corporation at 1-800-286-6070

NOTE: Replacement parts or service caused by failure to perform required maintenance is not covered by warranty.

NOTE: Equipment failure caused by product related issues are not covered by warranty.

CYCLE (Months)	ITEM
12	Replace hopper drum seal
12	Replace faucet seal
12	Inspect auger shaft for abnormal wear
12	Replace the auger shaft bushing
12	Replace the cooling shaft seal
12	Lubricate the motor shaft and motor shaft groove
Monthly	Clean condenser air filter
6 or as needed	Clean condenser coil
12	Inspect and clean the condenser fan

12 Month Maintenance

In order to maintain proper machine operation, the shaft seals and bushings need to be replaced as a Preventive Maintenance measure. A reminder message will appear every 12 months. Worn/dirty shaft seals/bushings may have a direct effect on torque sensing and prevent consistency with the product (thickness) in “ICE” mode.

Preparation

Determine if the machine can be serviced in place or if it will need to be moved to a suitable area. Review any concerns or ongoing issues with the manager that would need to be addressed during the PM visit. Clear a suitable work area around the machine, ask the location manager to provide you with a suitable location to relocate any items that may be around the machine temporarily.

Instructions

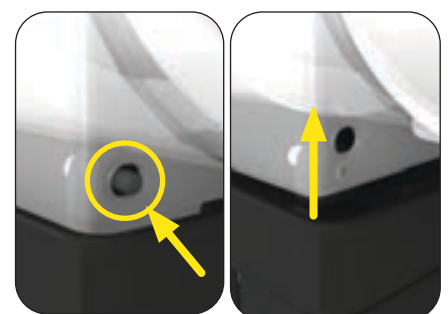
CAUTION – The dispenser is very heavy! Use care when lifting or moving it. Use at least two people to lift or move the dispenser.



1. Disconnect the machine from power.



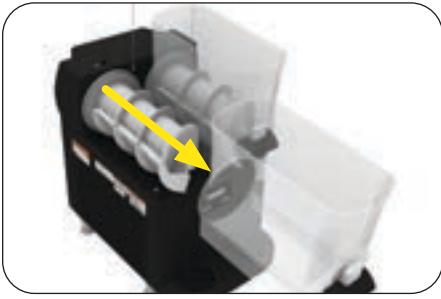
2. Disconnect and remove Lids on the Hoppers. Empty hoppers of remaining product.



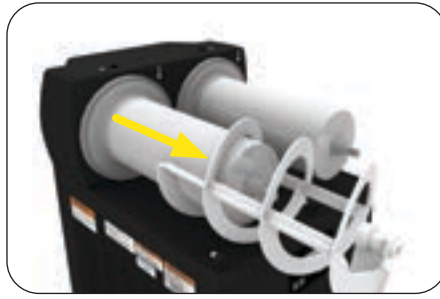
3. Depress the hopper lock plunger. Lift the hopper up slightly.

PREVENTIVE MAINTENANCE

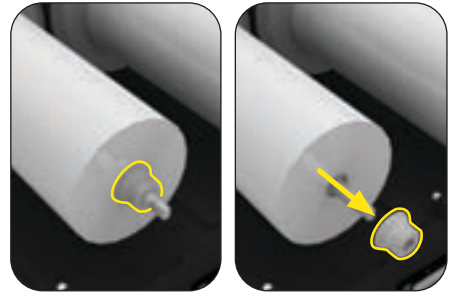
ULTRA PM Instructions



4. Pull forward to remove. Clean the machine as outlined in the Installation & Operating manual. A copy can be downloaded on BUNN's website.



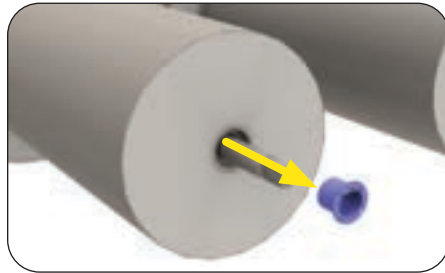
5. Pull the auger from the cooling drum.



6. Remove auger shaft seals.



7. Remove the cooling drum seal out the front of the drum using two pairs of needle-nose pliers. Carefully pinch two of the tabs on the seal and gently work the seal out of the drum.

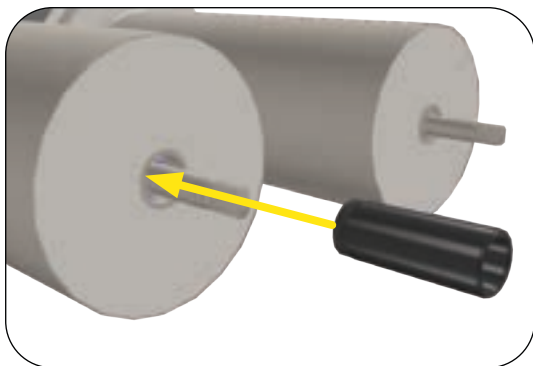


8. Use a pointed tool to remove the auger shaft bushing from the drum. Wipe clean the auger shaft and seal pocket in the drum. Apply a very light coat of lubricant ([M2550.0000](#)) to the shaft. Replace the bushings with P/N: [26781.0000](#)

NOTE: Do not get any lubricant in the pocket where the seal goes.



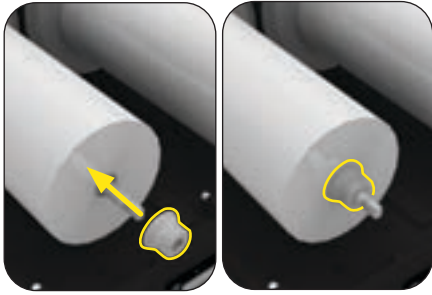
9. Use the provided tool to and seat the cooling drum seal P/N:[37593.0001](#) on the tool as shown.



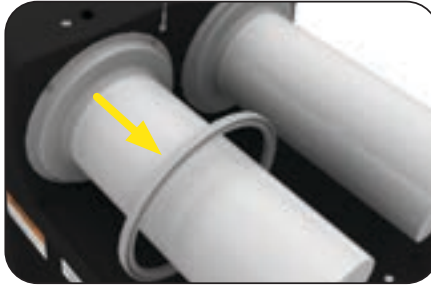
10. Install the new cooling drum seals. Use a small hammer to similar tool and tap the shaft seal into place using the install tool. This will properly seat the seal flush into the pocket.

PREVENTIVE MAINTENANCE

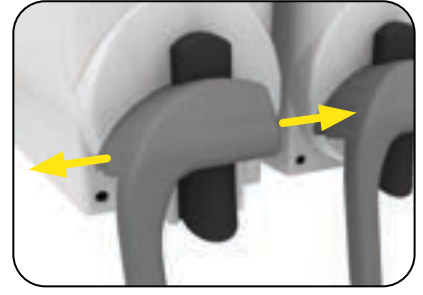
ULTRA PM Instructions



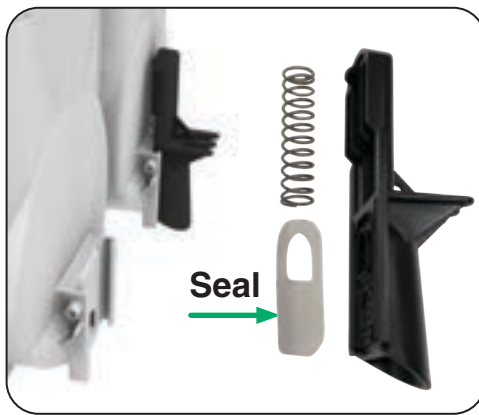
11. Replace the auger shaft seals. P/N: [26780.0000](#). Apply lubricant ([M2550.0000](#)) to the auger shaft seals and install on the shafts.



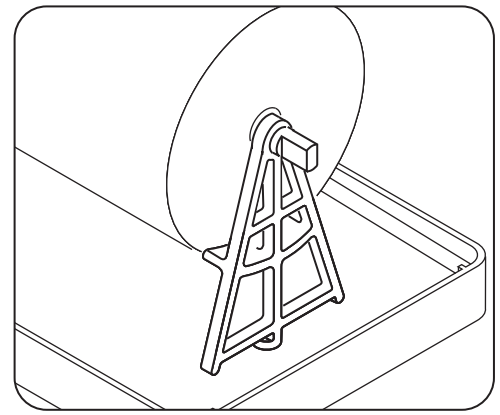
10. Remove the cooling drum seal from the rear of the drum. Replace the seal with P/N: [32079.0001](#).



12. Remove dispense handles. Spread the left side of the handle first, then the other and disconnect from the hopper.



13. Carefully slide the faucet valve up to remove the spring and faucet seal. Replace the faucet seal with P/N: [32268.1000](#)



14. Check alignment for the cooling drums (see next page).

NOTE: Krytox grease to be applied sparingly between the motor and auger shafts

PREVENTIVE MAINTENANCE

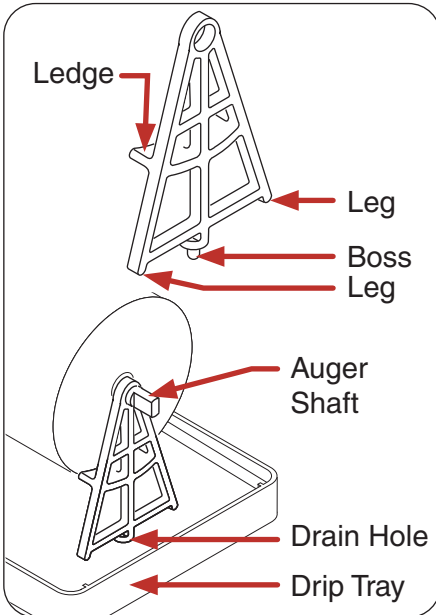
ULTRA PM Instructions

COOLING DRUM ALIGNMENT

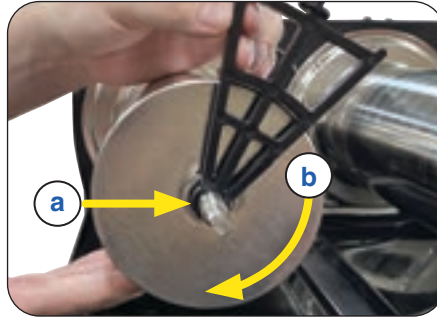
The “A” shaped Cooling Drum Shipping Supports, removed during Initial Setup, should be kept and used as tools to reset the alignment of the Cooling Drums if ever required.

Symptoms

Squeaky Operation, hopper lifts or won't seat properly, hopper is pushed to one side or the other.

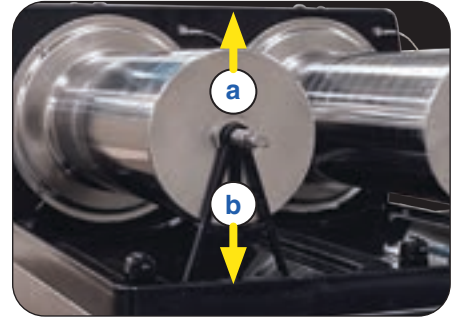


Cooling Drum Shipping Support



2. Check Alignment

- a. Place the “A” shaped Shipping Support on the Auger Shaft.
- b. Rotate Shipping Support down to vertical position.



3. a. Lift the Cooling Drum

- b. When the Shipping Support is in a vertical position, the “Boss” on the bottom will drop into the Hopper Drip Tray Drain hole.



4. When in its proper position, the Cooling Drum will cause a slight pressure on the Hopper Drip Tray Drain hole and the two Legs will be equidistant from the Hopper Drip Tray.

5. If an adjustment is needed, remove the support and gently force the free end of the Evaporator in the direction the adjustment is needed.
6. Reinstall the support, check the alignment, and readjust the Cooling Drums as required.

CAUTION: Never try to remove the cooling drums (4 screws) unless trained refrigeration technician is replacing the evaporator assembly.

TROUBLESHOOTING

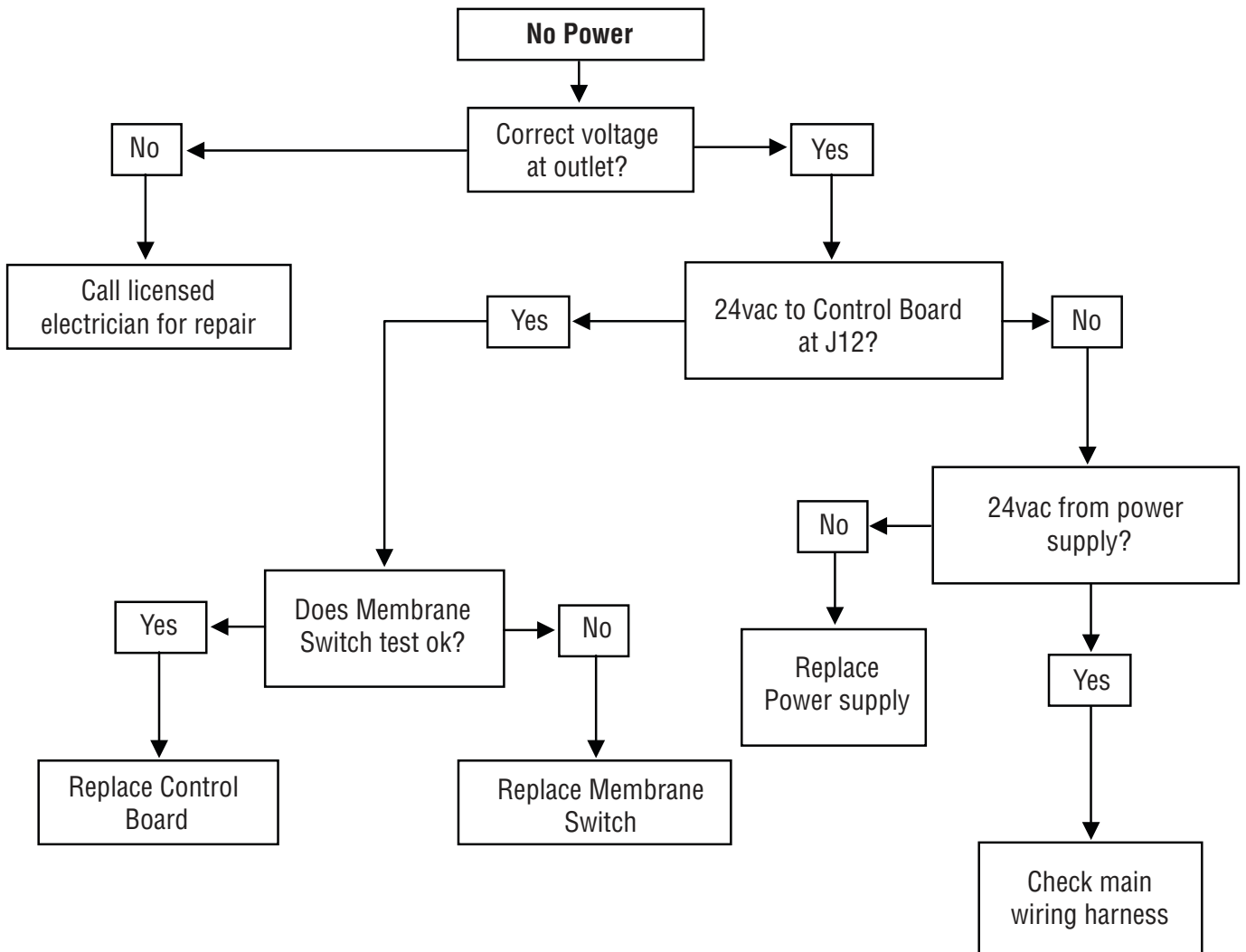
A troubleshooting guide is provided to suggest probable causes and remedies for the most likely problems encountered. If the problem remains after exhausting the troubleshooting steps, contact the Bunn-O-Matic Technical Service Department.

Fault messages are now incorporated within the software and may appear on the User display.

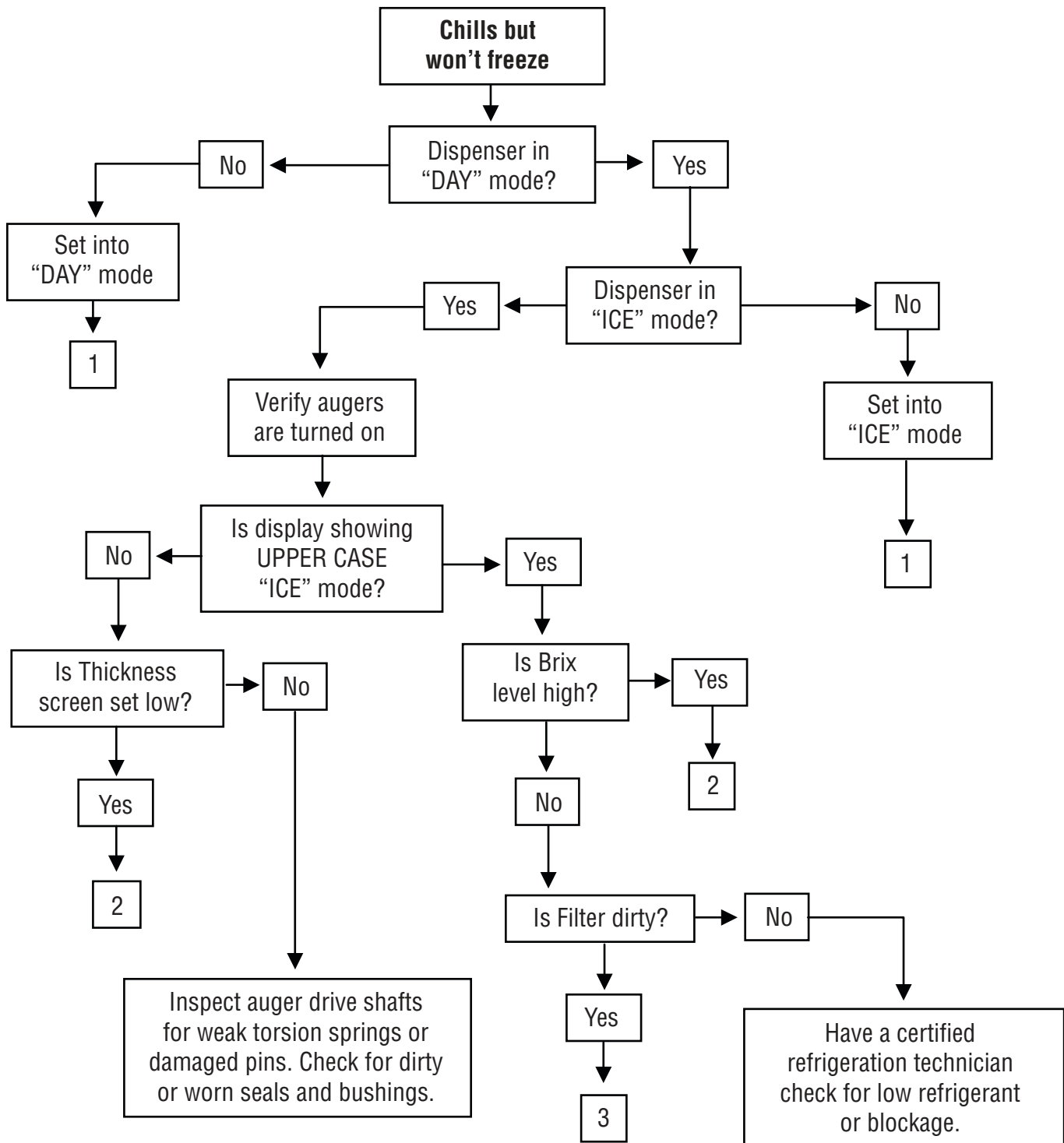
See Fault Messages.

- Inspection, testing, and repair of electrical equipment should be performed only by qualified service personnel.
- All electronic components have 120 volt ac and/or low voltage dc potential on their terminals. Shorting of terminals or the application of external voltages may result in board failure.
- Intermittent operation of electronic circuit boards is unlikely. Board failure will normally be permanent. If an intermittent condition is encountered, the cause will likely be a switch contact or a loose connection at a terminal or crimp.
- Keep away from combustibles.

- WARNING**
- Exercise extreme caution when servicing electrical equipment.
 - Unplug the dispenser when servicing, except when electrical tests are specified.
 - Follow recommended service procedures
 - Replace all protective shields or safety notices

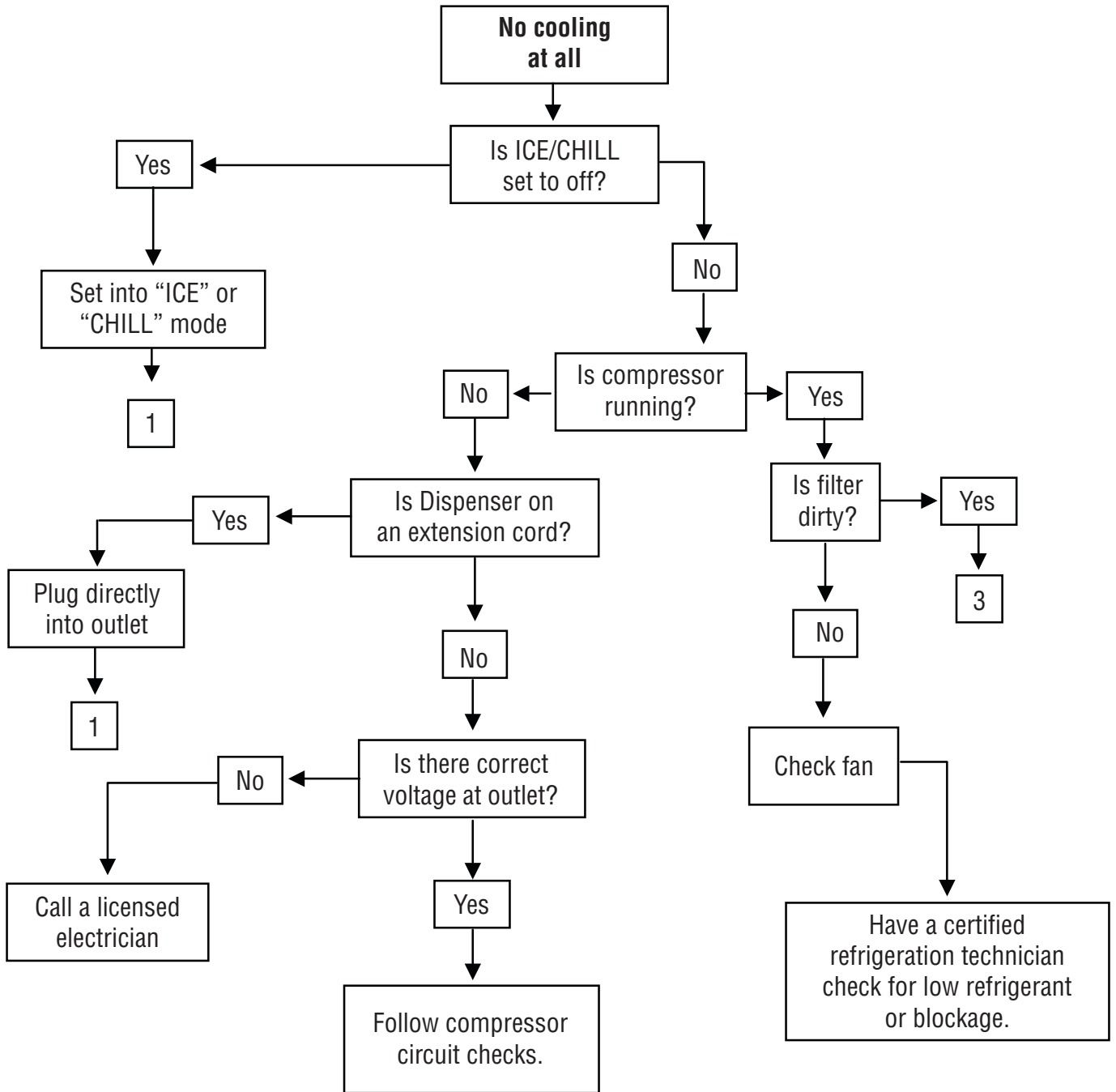


TROUBLESHOOTING



- 1- Done
- 2- Adjust
- 3- Clean

TROUBLESHOOTING

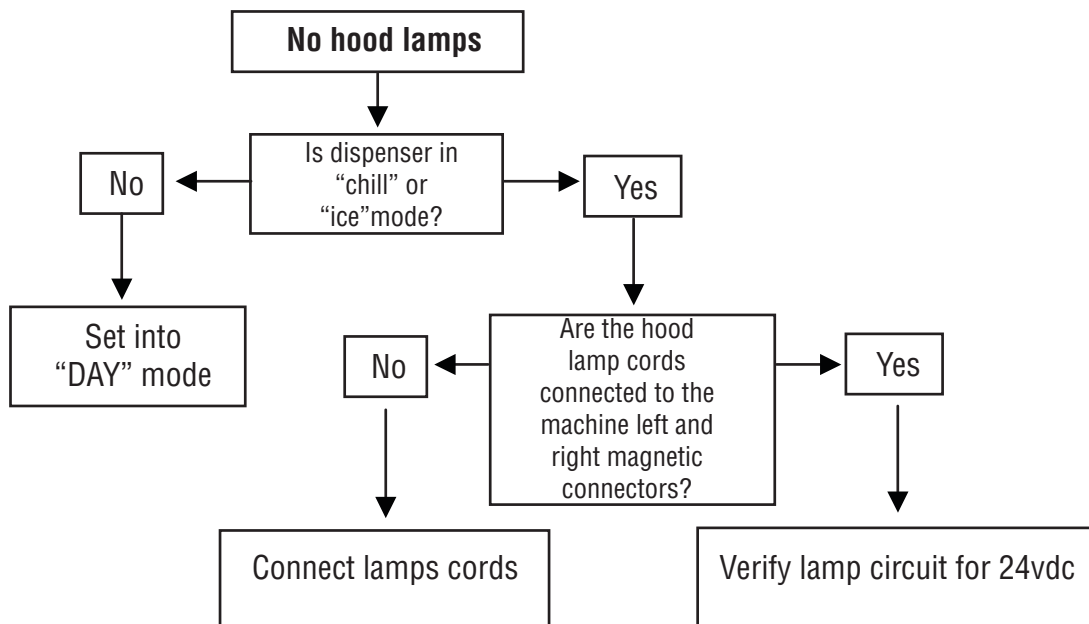
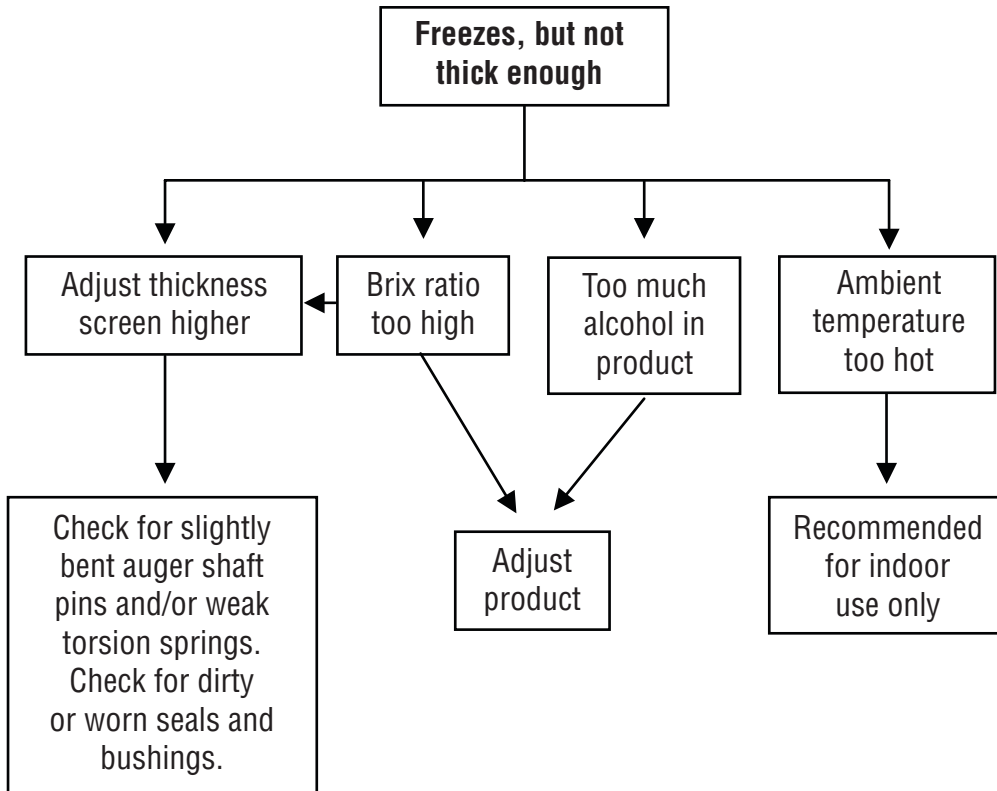


1- Done

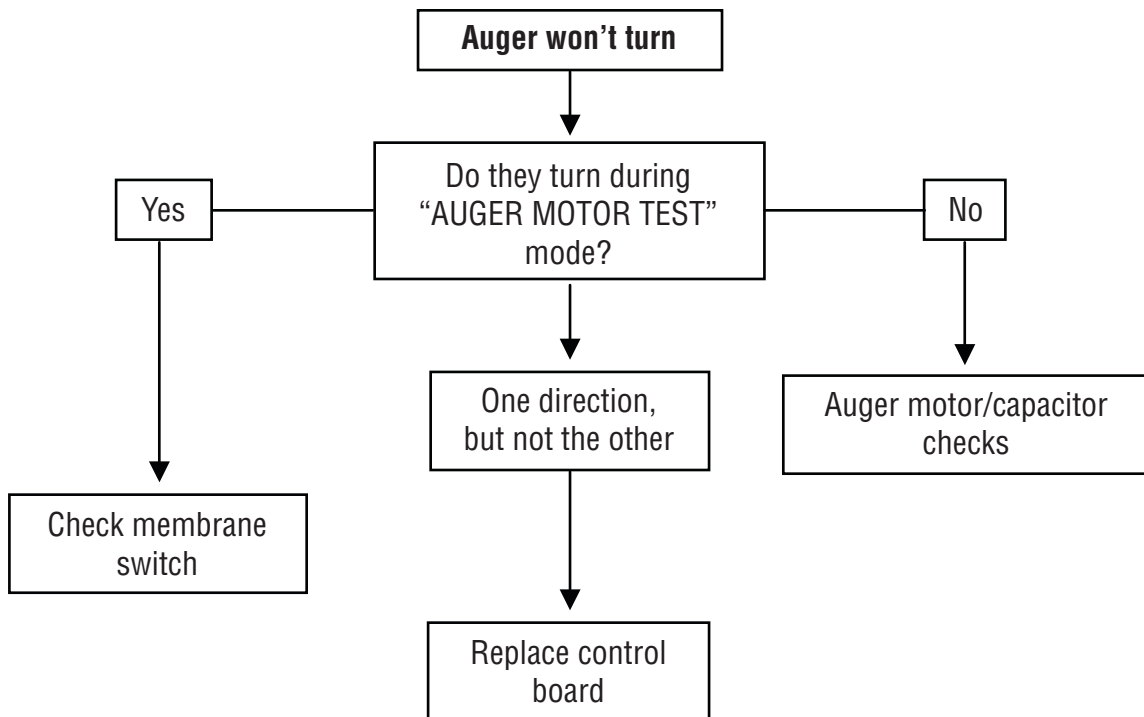
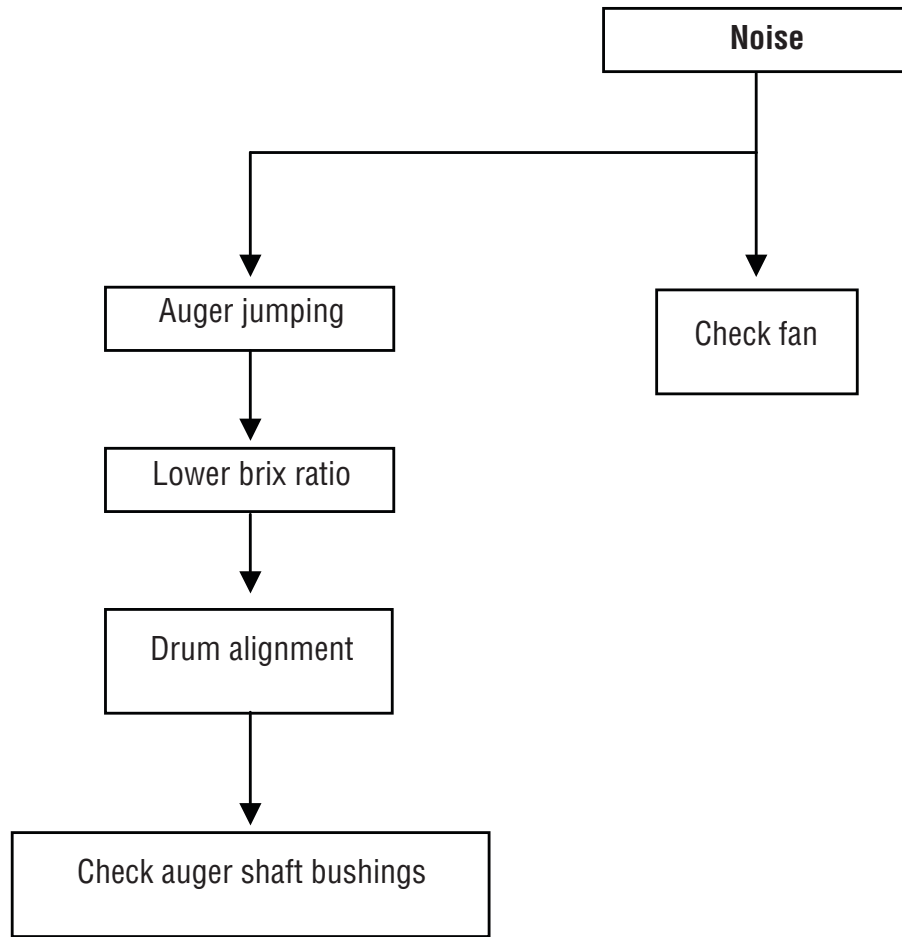
2- Adjust

3- Clean

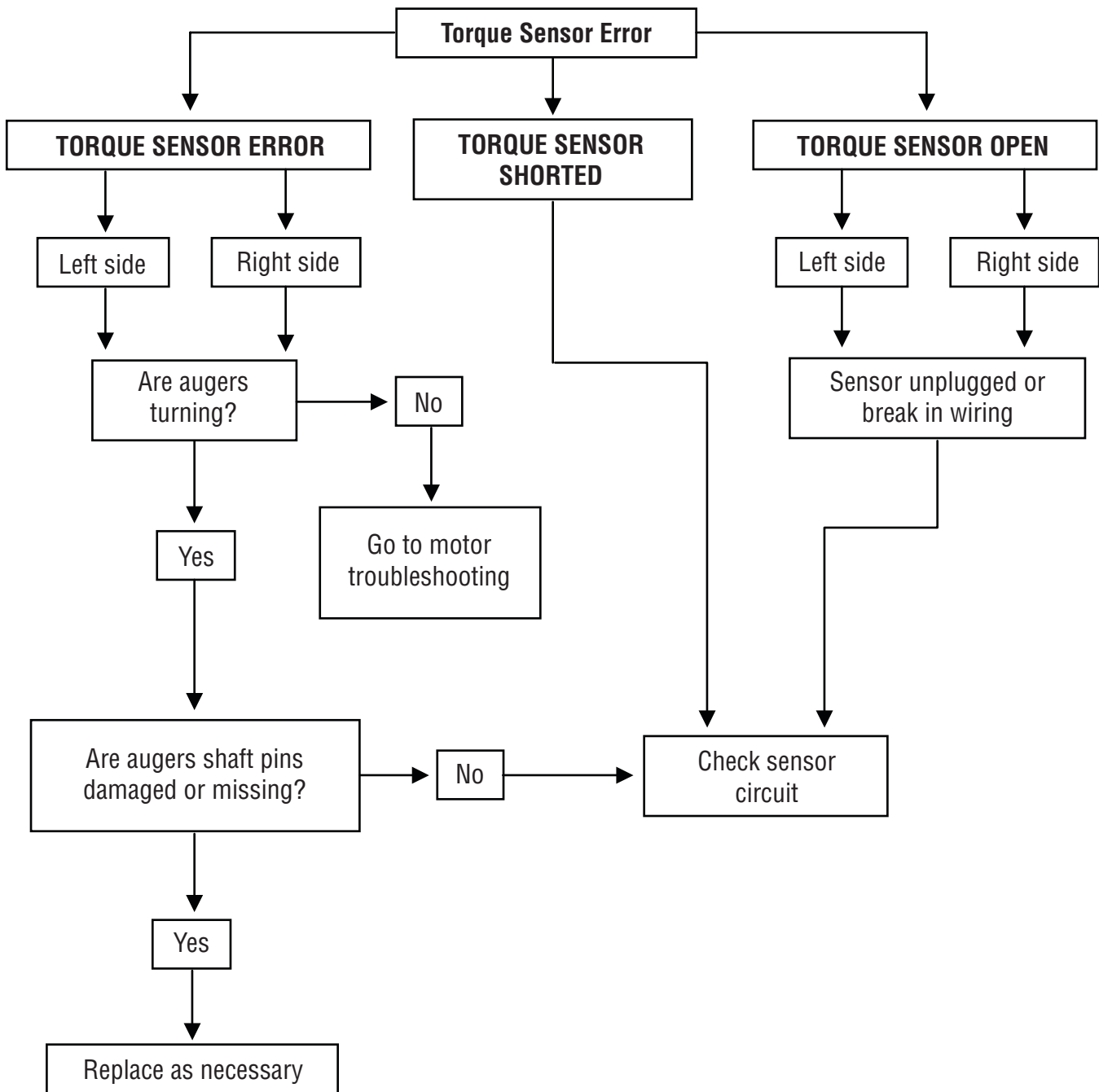
TROUBLESHOOTING



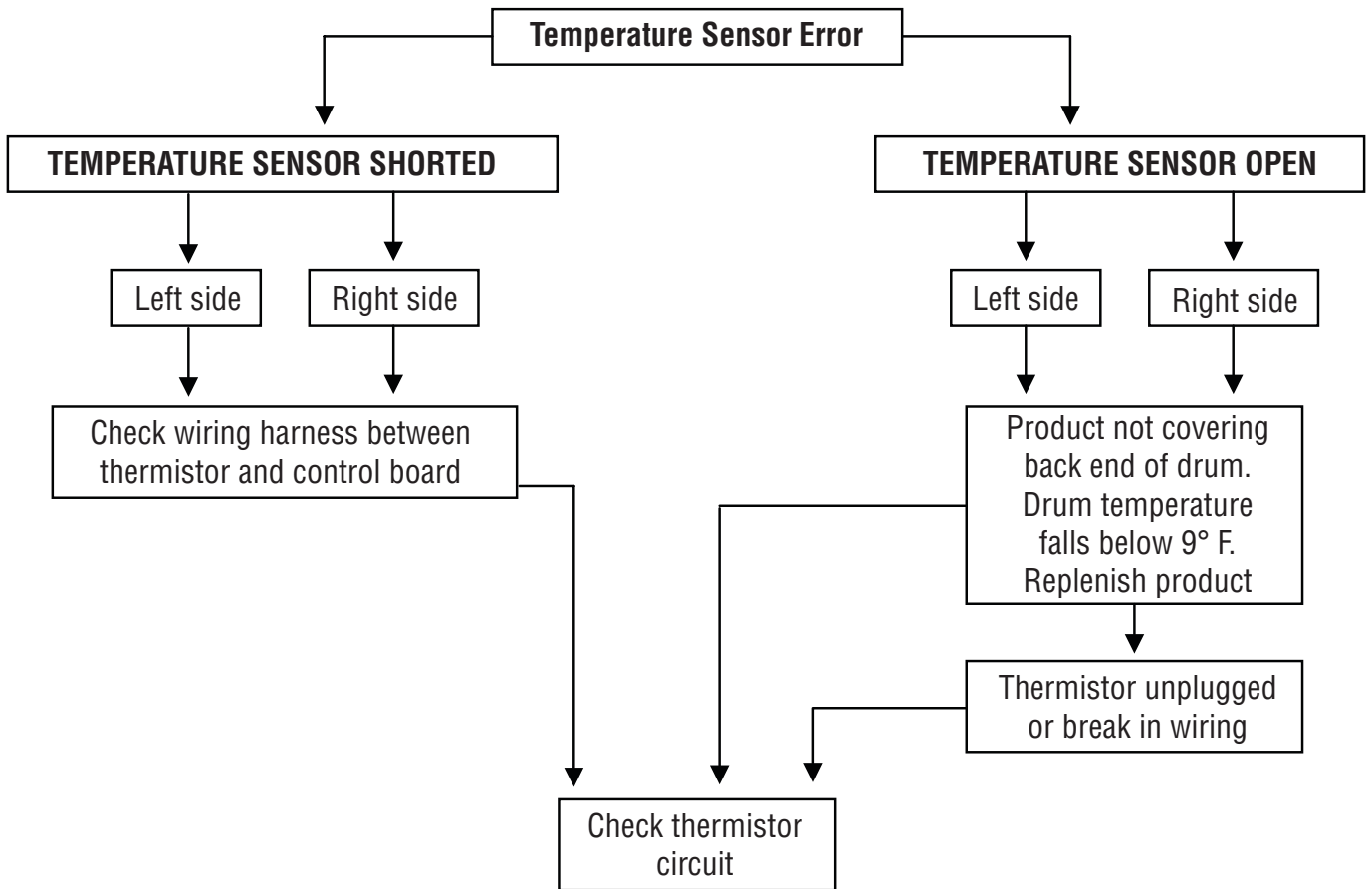
TROUBLESHOOTING



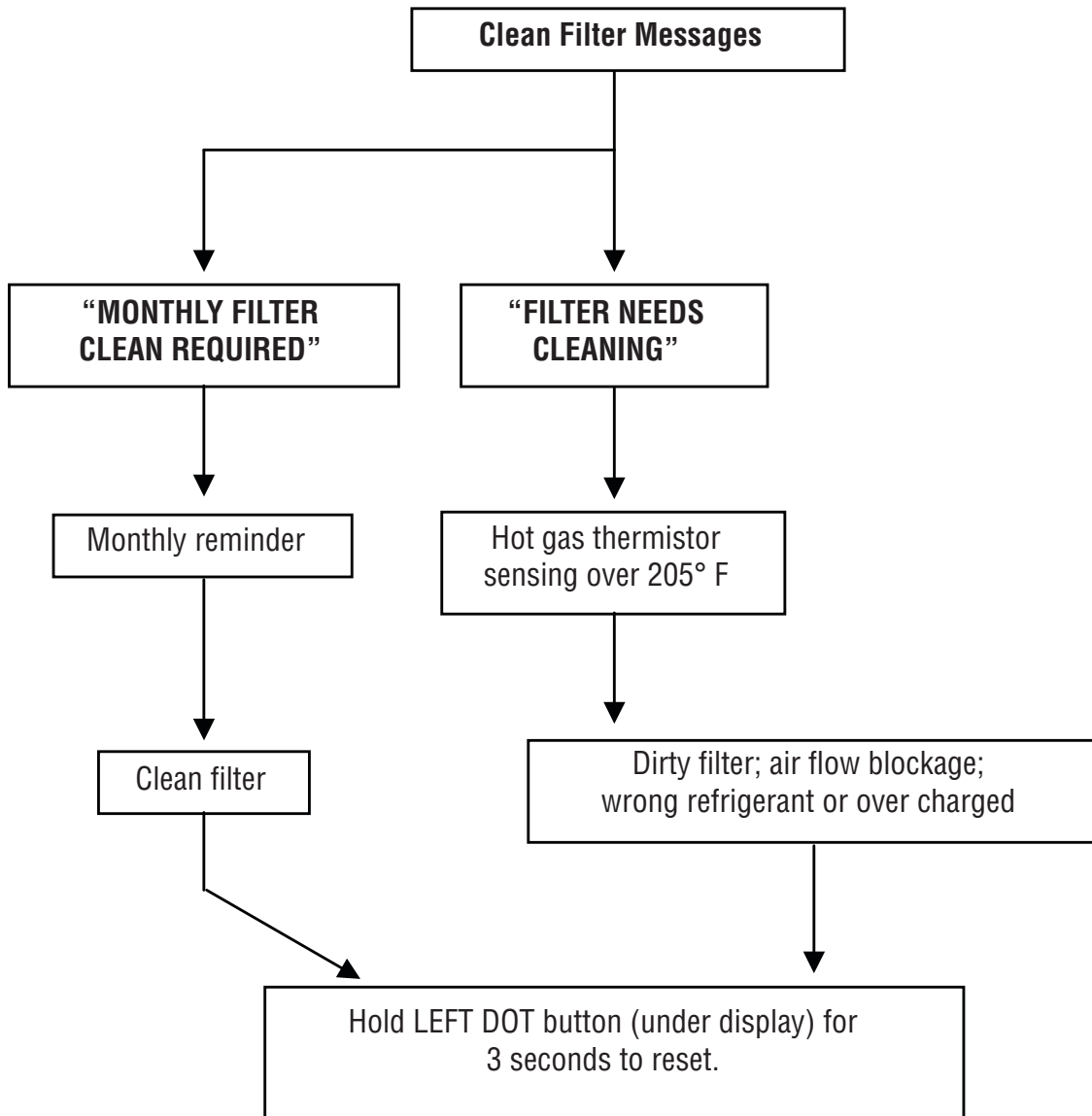
TROUBLESHOOTING



TROUBLESHOOTING



TROUBLESHOOTING



TROUBLESHOOTING

A common problem occurs when the proper preventive maintenance procedures are not followed. Failure to perform these procedures may result in damaged equipment and may not be covered by warranty.

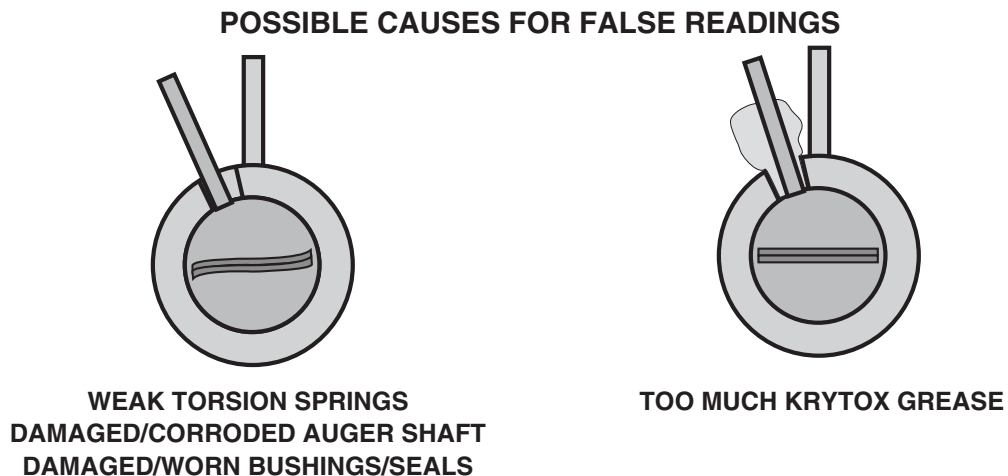
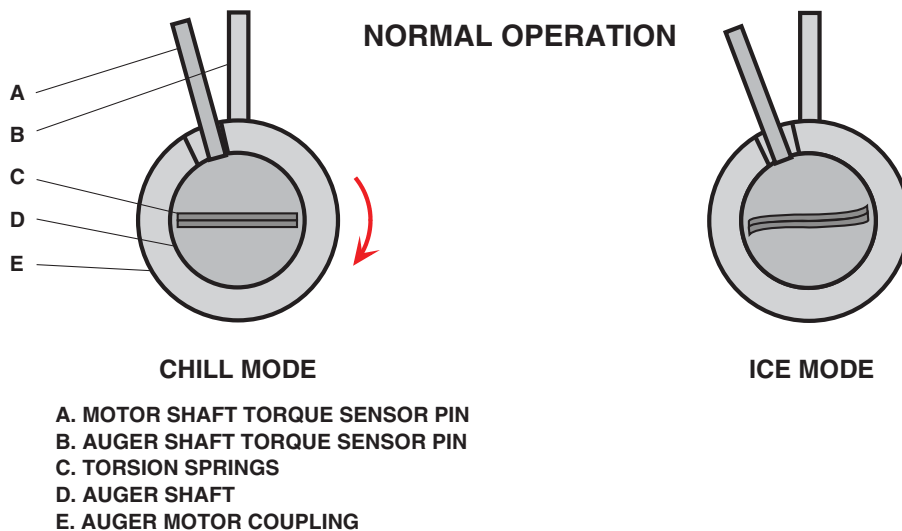
Fault Message: "CHECK LEFT SIDE" "PRODUCT MIX" "OR DRIVE SYSTEM"
"CHECK RIGHT SIDE" "PRODUCT MIX" "OR DRIVE SYSTEM"

Probable Cause: Inconsistent product mix ratio (very low brix percentage), residue build-up or too much Krytox grease on auger motor pin or defective position sensor (torque) board.

IMPORTANT: Please check the following items before assuming a refrigeration fault.

When the product does not freeze, there are several possibilities other than a failure in the refrigeration system. The torque between the auger motor and the frozen product is controlled by the torque sensor board measuring the distance between the pins on the coupler and shaft. When the distance between the pins reaches the maximum allowable distance, the compressor shuts off. The machine thinks the product thickness has reached the maximum and shuts off the compressor. The illustration below shows some of the other possible causes for the Fault Message and/or false reading from the torque sensor board.

Proper inspection and preventive maintenance (including daily cleaning) will avoid expensive repairs and costly down time.



FAULT MESSAGES

User Panel

The following are fault messages that “may” appear on the user LCD display. The issue will need to be resolved before the message goes away.

The resolution to clear the message / condition are:

- a) Instructional Information on Screen - Press Button
- b) Self Clears If Condition Goes Away and/or for Over 2 Minutes
- c) Self Clears If Condition Goes Away or User Overrides or Next Defrost Cycle is Started
- d) Self Clears When Next Defrost Cycle is Started
- e) Clears After User Performs a Proper Machine Cleaning
- f) Message Appears One Time

FILTER NEEDS CLEANING

Trip Condition: This message appears on the display when the hot gas sensor reads above 205 degrees fahrenheit for over 5 minutes. Press and hold button for 3 seconds to clear message after the filter has been cleaned.

Probable Cause: Dirty filter screen.

Clear Condition: a

HOT GAS SENSOR SHORT

Trip Condition: This message appears if the hot gas sensor detects a short.

Probable Cause: Defective hot gas sensor.

Clear Condition: b

HOT GAS SENSOR OPEN

Trip Condition: This message appears if the hot gas sensor is detected as open.

Probable Cause: Defective hot gas sensor or intermittent/open wiring connection between hot gas sensor and main control board.

Clear Condition: b

TEMPERATURE SENSOR SHORT

Trip Condition: This message appears if the left or right barrel temperature sensor detects a short.

Probable Cause: Defective cooling drum temperature sensor.

Clear Condition: b

TEMPERATURE SENSOR OPEN

Trip Condition: This message appears if the left or right barrel temperature sensor is detected as open.

Probable Cause: Defective cooling drum temperature sensor or intermittent/open wiring connection between cooling drum temperature sensor and main control board.

Clear Condition: b

FAULT MESSAGES

User Panel

CHECK PRODUCT MIX OR DRIVE SYSTEM

Trip Condition: This message appears when the left or right torque sensor detects a fault. This can be due to a pin problem or frozen auger.

Probable Cause: Inconsistent product mix ratio (very low brix percentage), residue build-up or too much Krytox grease on auger motor pin, defective position sensor (torque) board.

Clear Condition: b

REFILL

Trip Condition: The Low Level Detect feature must be enabled for this message to appear.

The message will say "LOW" in place of ice/chill on the barrel that is low. Will also flash the display and put a message on the top line "refill left/right".

Probable Cause: A pour over dispenser with product being low in the hopper or the level probe not installed on the hopper.

Clear Condition: b

REFILL PROTECTED

Trip Condition: This message appears if the left or right liquid level was low in the hopper longer than the Low Level To Chill timer. The Low Level to Chill feature must be enabled for this message to appear.

Probable Cause: Product low.

Clear Condition: c

REFILL FAULT

Trip Condition: This message appears if the left or right Auto Refill Time was too long (≥ 3 minutes) and could flash the hood lights.

Probable Cause: Intermittent level probe wiring between level probe and board, intermittent connection with the jumper pin on the power board between ground terminal and negative terminal. B-i-B empty, CO₂ supply empty, defective CO₂ pump, defective electric pump, defective proportional brix pump or internal components within the brix pump needs to be sanitized.

Clear Condition: a

PSI LOW

Trip Condition: This message appears if the left or right Auto Refill Pressure is too low.

Probable Cause: Defective syrup pressure switch, syrup switch wired incorrectly (should be wired to the normally open terminal), B-i-B empty, CO₂ supply empty, defective CO₂ pump, defective electric pump.

Clear Condition: b

DEFROST HEATER FAULT > CHECK PTC

Trip Condition: This message appears if the left or right PTC Heater did not see desired initial temperature rise during Defrost.

Probable Cause: Defective PTC heater. Open wiring connection between the PTC heater and the control board.

Clear Condition: c

DEFROST HTR > TIME TOO LONG > CHECK PTC

Trip Condition: This message appears if the left or right PTC Heater took too long to fully complete a Defrost cycle.

Probable Cause: Defective PTC heater. Open wiring connection between the PTC heater and the control board.

Clear Condition: c

FAULT MESSAGES

User Panel

DEFROST INCOMPLETE

Trip Condition: This message appears if the left or right Barrel Defrost did not complete successfully (possibly either cancelled or defrost time frame too short).

Probable Cause: Given the condition per location, the “Defrost” time set too short. Operator should enter software menu and increase the Defrost time.

Clear Condition: c

CLOCK FAILURE / INVALID DATE / INVALID TIME

Trip Condition: This message appears if there’s an issue with reading or setting of the RTCC or a potential battery failure was detected.

Probable Cause: Defective main control board.

Clear Condition: b

USB OVER CURRENT

Trip Condition: This message appears if a USB over current condition was detected. This is likely a short on the USB connector.

Probable Cause: Defective main control board.

Clear Condition: b

MONTHLY FILTER CLEANING REQUIRED

Trip Condition: This message appears if the 30 day filter clean is due on the machine.

Probable Cause: Friendly reminder message.

Clear Condition: a

CLEAN DUE TODAY / CLEAN DUE NOW / CUSTOM USER TEXT

Trip Condition: This message appears if cleaning is due on the machine.

Probable Cause: Feature enabled in software menu.

Clear Condition: e

SHAFT SEAL MAINTENANCE DUE

Trip Condition: This message appears if the 12 Month PM is due for the machine. The 12 Month PM feature must be enabled for this message to appear.

Probable Cause: 12 Month Pm feature enabled. Operator/Technician must enter software program, enter “Service Settings”, then confirm “Yes” under the “PM Complete” menu.

Clear Condition: N/A

BOOTLOADER NEEDS UPDATE

Trip Condition: This message appears if the bootloader is seen as out of date / needs updated.

Probable Cause: BootLoader is out of date.

Clear Condition: f

EQUIPMENT SERVICE PANELS

This section provides procedures for testing and replacing various major components used in this dispenser should service become necessary. Refer to Troubleshooting for assistance in determining the cause of any problem.

WARNING: Inspection, testing, and repair of electrical equipment should be performed only by qualified service personnel. The dispenser should be disconnected from the power source when servicing, except when electrical tests are required and the test procedure specifically states to connect the dispenser to the power source.

Component Access Panels

WARNING: Disconnect the dispenser from the power source before the removal of any panel or the replacement of any component.

All components are accessible by removal of the auger motor cover, lower drip tray, front cover and the left and right side covers.

Refer to the contents listing for component location.



SERVICE - FRONT PANEL COMPONENTS

Control Board and Auto-Fill Board

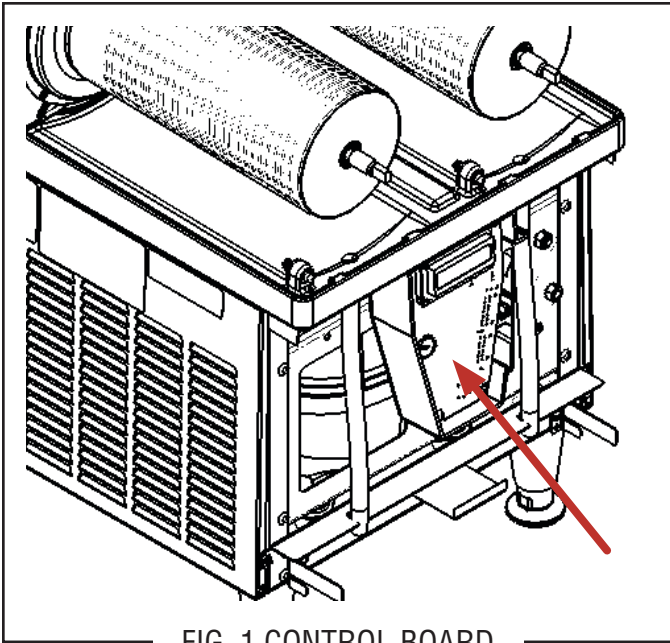


FIG. 1 CONTROL BOARD

Location:

The control board is located behind the front panel, on the front of the chassis.

1. Remove the drip tray.
2. Loosen 2 screws on the underside of each side panel. Lower the side panel while gently pulling outward to remove panel.
3. Locate the single screw on the left and right side securing the front panel to the frame.
4. Lower front of the machine, remove 1 screw from underside the front panel.
5. The membrane switch will need to be disconnected before full removal of front panel. Gently lower front panel and rest on the counter and disconnect switch membrane from the wiring harness.

Test Procedures:

1. Disconnect the dispenser from the power source.
2. Remove the left and right side panels. Remove the front panel and unplug membrane switch.
3. Connect the dispenser to the power source.
4. With a voltmeter, check the supply voltage across J12-2 pin connector.

The indication must be: 24.0VDC

If voltage is present as described and the dispenser does not operate, replace Control Board.

If voltage is not present as described, refer to the Wiring Diagram and check the dispenser universal power supply and wiring harness.

Part Removal and Replacement:

1. Disconnect the dispenser from the power source.
 2. Remove 3 screws securing main control board and set aside protective shield.
 3. Disconnect 12pin, 14pin, 2pin and 6pin connector from control board.
 4. Disconnect the 12pin short wiring harness from the control board.
 5. On models with Auto-Fill (CFV OR LAF Models), remove the auto-fill adapter board from the backside of the main control board. See FIG. 2.
- NOTE: The 12pin short wiring harness and Auto-Fill board will connect onto the replacement control board.
6. Reconnect all harness connectors onto the control board.
 7. Reinstall main control and protective shield

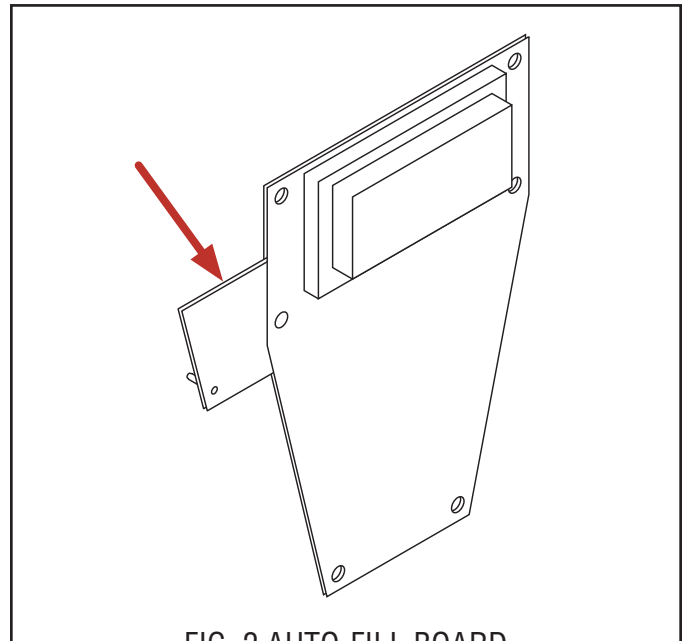


FIG. 2 AUTO-FILL BOARD

SERVICE - FRONT PANEL COMPONENTS

Membrane Switch

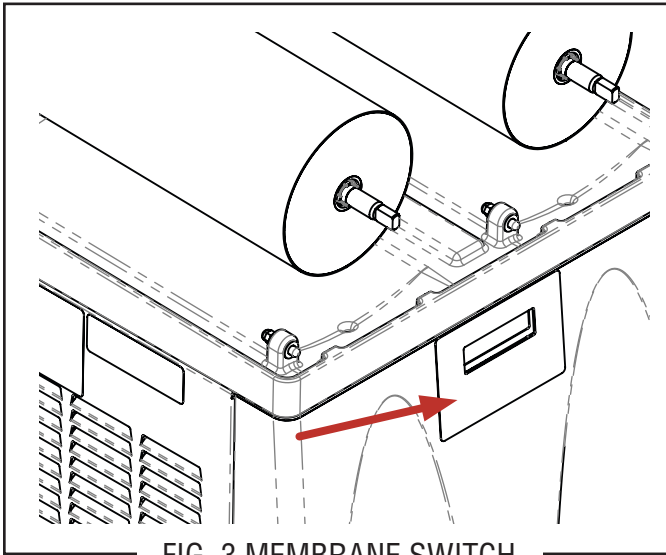


FIG. 3 MEMBRANE SWITCH

Location:

The membrane switch is located on the front panel.

Front Panel Removal:

1. Remove the drip tray.
2. Loosen 2 screws on the underside of each side panel. Lower the side panel while gently pulling outward to remove panel.
3. Locate the single screw on the left and right side securing the front panel to the frame.
4. Lower front of the machine, remove 1 screw from underside the front panel.
5. The membrane switch will need to be disconnected before full removal of front panel. Gently lower front panel and rest on the counter and disconnect membrane switch from the wiring harness.

Test Procedures:

1. Enter the software program and scroll to main "Service Tools" menu.
2. Press the "Right Dot" switch to answer "Yes".
3. Press the "Center Dot" switch to scroll through the menus until "Test Switches" menu is displayed.

NOTE: The Test Switches menu will allow the operator or technician to test the operation of the individual switches on the membrane pad.

4. Press each individual switch to see if the input is recognized by the switch by displaying the switch name.

If the input is **not** recognized by pressing a switch on the membrane pad, replace membrane switch.

Membrane Switch Diagram:

NOTE: #7 - Common to all the buttons.

- #7 - #1 (shield) no continuity
- #7 - #2 (Left Auger)
- #7 - #3 (I/O)
- #7 - #4 (not used)
- #7 - #5 (Left ICE/CHILL/OFF)
- #7 - #6 (LEFT DOT)
- #7 - #8 (CENTER DOT)
- #7 - #9 (not used)
- #7 - #10 (RIGHT DOT)
- #7 - #11 (Right Auger)
- #7 - #12 (Right ICE/CHILL/OFF)

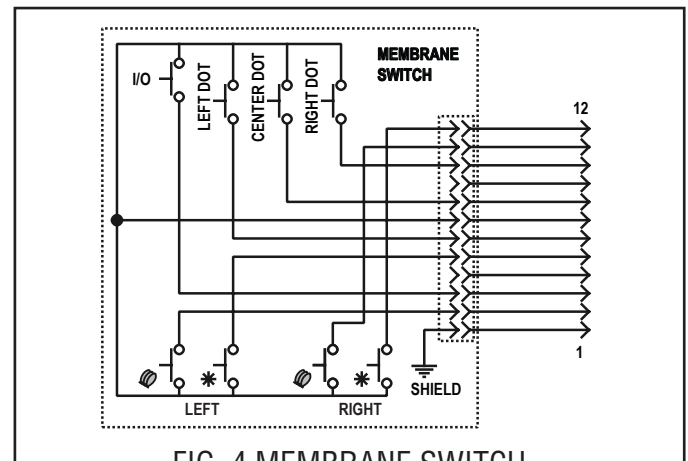


FIG. 4 MEMBRANE SWITCH

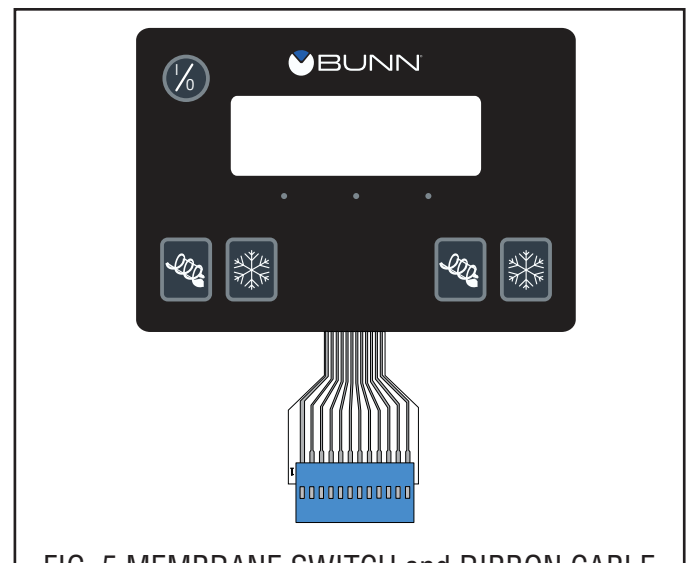


FIG. 5 MEMBRANE SWITCH and RIBBON CABLE

SERVICE - FRONT PANEL COMPONENTS

Membrane Switch

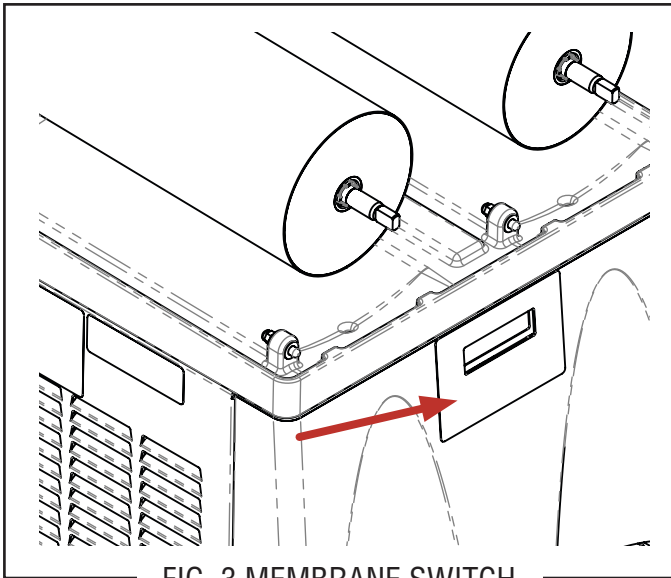


FIG. 3 MEMBRANE SWITCH

Part Removal and Replacement:

1. Disconnect the dispenser from the power source.
2. Remove right and left side panels.
3. Remove front panel and disconnect membrane switch ribbon from wiring harness.
4. Open the restraint clamp securing the membrane switch ribbon.
4. Peel the old membrane switch off the front panel and discard. Clean any remaining adhesive from front panel with mineral spirits and then alcohol.
5. Remove protective paper backing from back side of new membrane switch.
6. Guide ribbon cable through narrow slot in panel. Carefully position new membrane switch on panel, while centering display window to opening.
7. Reconnect the ribbon cable to the short wiring harness from the Control Board.

NOTE: The black wire in wiring harness should correspond to the #1 side printed on the clear portion of the ribbon cable.

8. Close the restraint clamp securing the membrane switch ribbon.

NOTE: Before continuing, check that the ribbon cable is properly connected to the control board wiring harness and not a pin off in either direction.

SERVICE - HOPPER LID ASSEMBLY

LED/CBA and MAG Cord Assembly

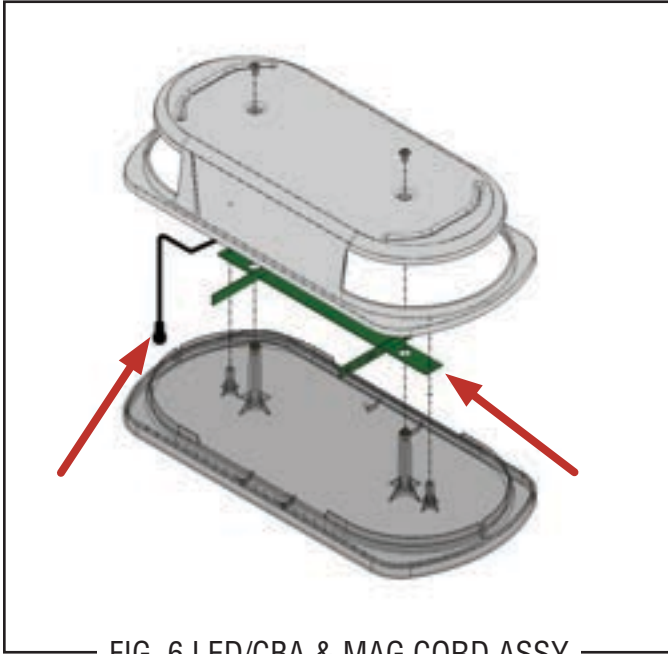


FIG. 6 LED/CBA & MAG CORD ASSY

Location:

The LED/CBA and cord are located inside the hopper lid.

Hopper Lid Removal:

1. Disconnect the lid mag cord from the base mag contact assembly by gently raising the cord away from the magnetic field.

Test Procedures:

1. Ensure hopper cover mag cord assembly is connected to the mag contact assembly located on the upper drum base.
2. Enter the software program and scroll to main "Service Tools" menu.
3. Press the "Right Dot" switch to answer "Yes".
4. Press the "Center Dot" switch to advance onto "Test Outputs" menu.
5. Press the "Right Dot" switch to answer "Yes".
6. Press the "Center Dot" switch to scroll through the menus until "Left Lid Light" menu is displayed.

NOTE: The "Left Lid Light" menu will allow the operator or technician to test the operation of the Left Lid Light or output of the main control board.

7. Press the "Left Dot" switch to answer "ON". Left Lid Light will illuminate.

NOTE: Power output to the Left or Right Lid Light is 24VDC.

8. Press the "Center Dot" switch to advance onto "Right Lid Light" menu.

9. Press the "Left Dot" switch to answer "ON". Right Lid Light will illuminate.

If voltage is present and Lid Light is not illuminated as described, the LED/CBA & Mag Cord Assembly is faulty.

If voltage is not present as described, go to Mag Contact Assembly and/or retrace the wiring circuit to find the fault.

Part Removal and Replacement:

1. Remove 2 screws on top of the lid to separate the lid assembly.
2. Remove 2 screws securing the LED/CBA assembly to the lower liner. Remove assembly.
3. Install replacement LED/CBA with mag cord and secure with 2 screws.

NOTE: Ensure cord is routed in the groove.

4. Install hopper cover over lower liner and secure with the 2 screws.

SERVICE - REAR COVER COMPONENTS

MAG Contact Assembly

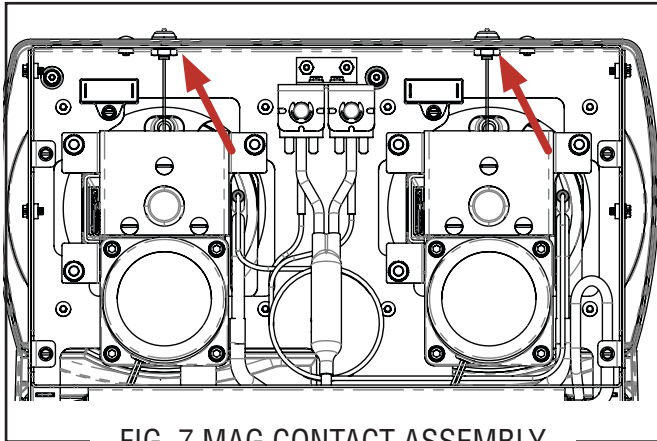


FIG. 7 MAG CONTACT ASSEMBLY

Location:

The LED mag contact assembly is located in the top center of the cooling drum mount.

Rear Cover Removal:

1. Remove 4 screws securing rear cover.
2. Grab cover and pull away from machine.

Test Procedures:

1. Perform LED/CBA & Mag Cord Assembly test procedure.
2. If a Lid Light does not illuminate, check to ensure Mag Contact 2-pin connector is connected to the machine wiring harness.
3. Check the Input and Output voltage at the Mag Contact 2 pin wiring connector when performing the LED/CBA & Mag Cord Assembly test procedure.
4. 24VDC present on the input side and not the Output side - Replace Mag Contact Assembly
24VDC not present on the input side (machine wiring harness connector) - Retrace the wiring circuit to find the fault.

Part Removal and Replacement:

1. Disconnect the dispenser from the power source.
2. Locate the Mag Contact Assembly 2-pin wire connector, push-in tab to release connector from machine wiring harness connector.
3. Unscrew the nut securing the Mag Contact Assembly.

4. Lift Mag Contact Assembly from the cooling drum mount hole.
5. Replace Mag Contact Assembly into cooling drum mount hole and secure with nut.
6. Reconnect Mag Contact 2-pin connector to the machine wiring harness connector.



FIG. 8 MAG CONTACT ASSEMBLY

SERVICE - REAR COVER COMPONENTS

Left and Right Auger Motors

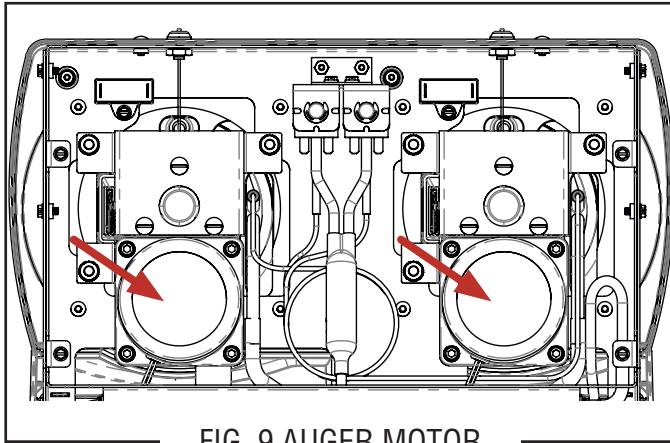


FIG. 9 AUGER MOTOR

Location:

The auger motors are located at the upper rear of the dispenser chassis behind the auger motor cover.

Rear Cover Removal:

1. Remove 4 screws securing rear cover.
2. Grab cover and pull away from machine.

Test Procedures:

Option 1:

1. Remove the hopper from the same side as the motor to be tested.
2. Turn "ON" the appropriate auger switch.
3. Nudge the auger to start it turning.

If the auger doesn't turn, replace the motor.

If auger starts to turn, replace the start capacitor.

WARNING: All new, old or defective capacitors need to be treated as they hold a "charge" and can be harmful. Before testing a capacitor, safely discharge the capacitor.

Option 2:

1. Enter the software program and scroll to main "Service Tools" menu.
2. Press the "Right Dot" switch to answer "Yes".
3. Press the "Center Dot" switch to advance onto "Test Outputs" menu.

4. Press the "Right Dot" switch to answer "Yes".
 5. Press the "Center Dot" switch to scroll through the menus until "Test Augers?" menu is displayed.
 6. Press the "Right Dot" switch to answer "Yes" to enter "Left Auger Test" menu.
- NOTE: The "Left Auger Test & Right Auger Test" menu will allow the operator or technician to test the Forward and Reverse operation of the auger motor.
7. Press the "Right Dot" switch to start Forward rotation of the auger motor, press "Right Dot" again to start Reverse rotation of the auger motor.
 8. Press the "Center Dot" to go to "Right Auger Test" menu.
 9. Press the "Right Dot" switch to start Forward rotation of the auger motor, press "Right Dot" again to start Reverse rotation of the auger motor.

Forward rotation and no reverse rotation, relay (reverse) is defective on CBA, replace control board.

Reference: Control Board Triac Diagram

Control Board/Relay 1 - Left Auger Motor

Control Board/Relay 2 - Right Auger Motor

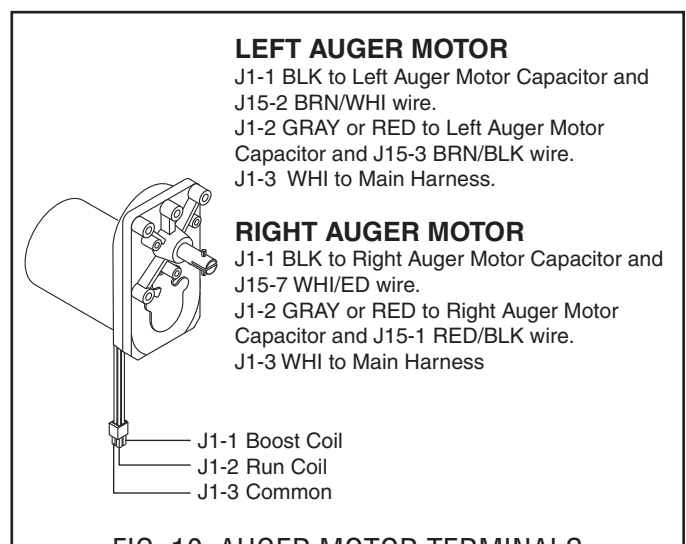


FIG. 10 AUGER MOTOR TERMINALS

SERVICE - REAR COVER COMPONENTS

Auger Motors

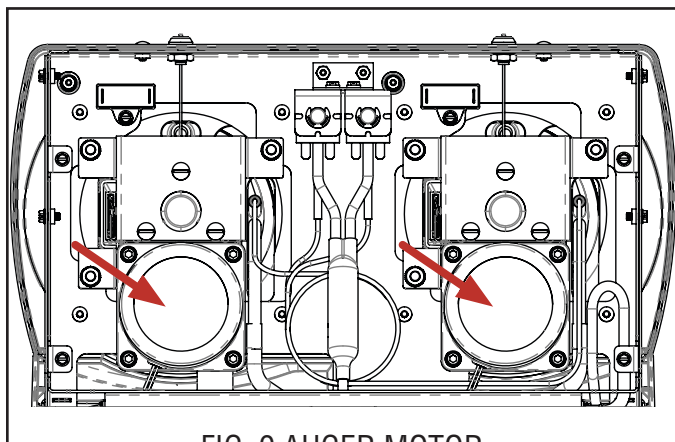


FIG. 9 AUGER MOTOR

8. Reinstall the 3 nuts that secure the motor mounting bracket to the chassis.
9. Reconnect the auger motor 4-pin connector to the machine wiring harness.

Part Removal and Replacement:

1. Disconnect the dispenser from the power source.
2. Locate the auger motor 4-pin connector, push-in the connector tab to release connector from the machine wiring harness.

NOTE: BUNN recommends the flats on the front of the shaft that engage the auger nose are set to a horizontal position, the pins will not be in the torque sensor board before removal of the motor assembly.

3. Use a 7/16" nut driver or deep well socket to remove the 3 nuts securing the auger motor bracket to the chassis.
4. Grab the auger motor with mounting bracket and begin pulling motor away from auger shaft being careful that the motor .188 pin clears the board sensors.
5. If the replacement motor does not have the mounting bracket, transfer original bracket/screws from defective motor over to the replacement motor by removing the 3 screws securing the bracket to the motor gear box.

NOTE: Before install of new motor assembly, ensure a small amount of Krytox grease (M2548.1000) is present on the torsion spring bearing that will engage the auger shaft torsion springs.

7. Being careful, install replacement motor with bracket, engaging the motor shaft into the auger shaft torsion springs.

SERVICE - REAR COVER COMPONENTS

Left and Right Auger Motor Capacitor

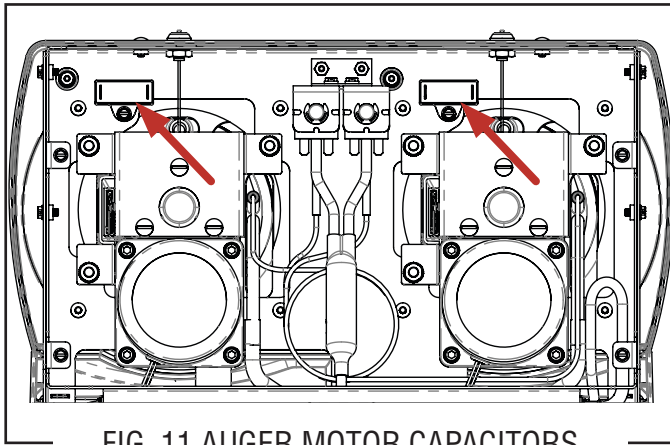


FIG. 11 AUGER MOTOR CAPACITORS

Location:

The auger motor capacitors are located at the upper rear of the dispenser chassis, above each auger motor.

WARNING: All new, old or defective capacitors need to be treated as they hold a “charge” and can be harmful. Before testing a capacitor, safely discharge the capacitor. Once the capacitor is fully discharged you can now begin testing of the capacitor.

Rear Cover Removal:

1. Remove 4 screws securing rear cover.
2. Grab cover and pull away from machine.

Test Procedures:

Option 1:

1. Remove the hopper from the same side as the motor to be tested.
2. Turn “ON” the appropriate auger switch.
3. Nudge the auger to start it turning.

If the auger doesn't turn, replace the motor.

If auger starts to turn, replace the start capacitor.

Option 2:

Examine the capacitor for bulging or fluid leakage. If seen, replace capacitor.

No bulging or leakage - Use a capacitance meter to measure the capacitance. The capacitance value should be the rated value or within the allowable tolerance range.

Auger Motor Capacitor Ratings:

120V Models:

Capacitance - $4.0\mu\text{F}$ -5%/+10%, VOLTAGE - 250 VAC 50/60 Hz.

240V Models:

Capacitance - $1.25\mu\text{F}\pm 5\%$, VOLTAGE - 500 VAC 50/60 Hz

If it is outside the allowable capacitance range, then the capacitor needs to be replaced.

Part Removal and Replacement:

1. Disconnect the wires from the auger motor capacitor.
2. Remove 1 screw securing the capacitor to the machine frame.
3. Install replacement capacitor with screw removed in step 2.
4. Reconnect the wires to the capacitor terminals.

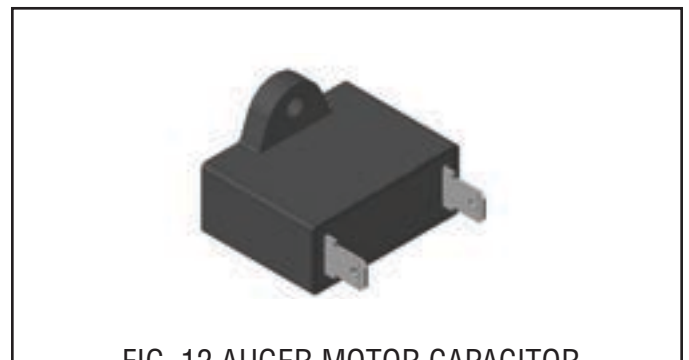


FIG. 12 AUGER MOTOR CAPACITOR

SERVICE - REAR COVER COMPONENTS

Left and Right Torque Sensor Board

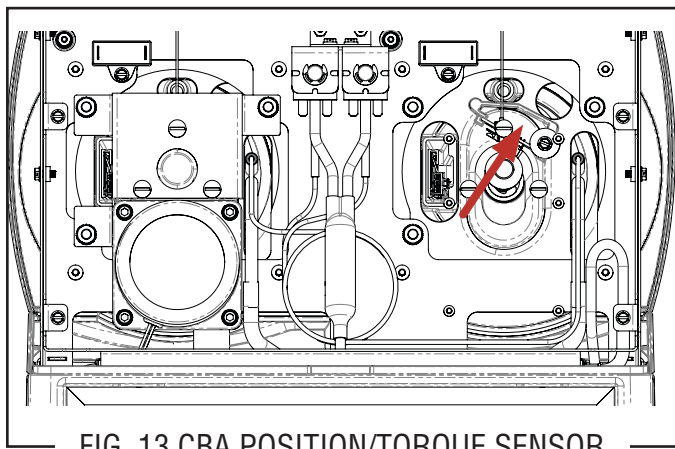


FIG. 13 CBA POSITION/TORQUE SENSOR

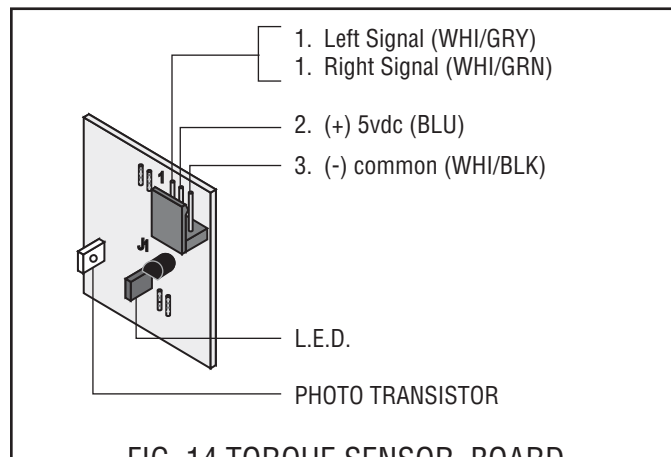


FIG. 14 TORQUE SENSOR BOARD TERMINALS

Location:

The torque sensor circuit board is located on the upper rear of the cooling drum.

NOTE: The above pictorial has one auger motor hidden to show location of the position sensor.

Rear Cover Removal:

1. Remove 4 screws securing rear cover.
2. Grab cover and pull away from machine.

Test Procedures:

NOTE: Best to perform Part Removal Instruction steps 1 thru 6 to access circuit board connector for testing procedure.

1. Place black meter lead at J1-3 (common) and red lead at J1-1 (signal). Set meter to 10 - 20volts DC scale. Turn on power switch.

DO NOT TURN ON AUGERS!

2. Using a strip of paper, momentarily block the light path between red LED and white photo transistor. If the meter displays 5vdc when blocked and 0v when unblocked, then the Torque Sensor is good. If there is no 5vdc reading, verify that both red and white sensors are clean. See FIG. 14.
3. If there is still no 5vdc reading when blocked, place the red meter lead at J1-2 and verify that there is 4.5vdc supplied to Torque Sensor. If there is no 5vdc supplied, check wiring between control board and Torque Sensor. If wiring is ok, then replace the main control board.

SERVICE - REAR COVER COMPONENTS

Torque Sensor Circuit Board

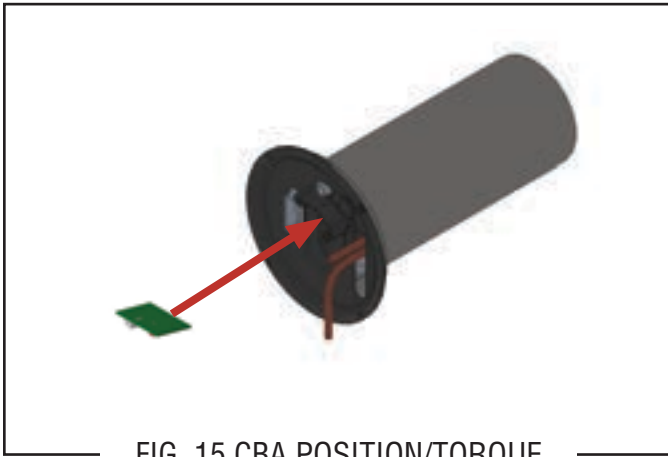


FIG. 15 CBA POSITION/TORQUE
SENSOR

11. Reinstall the 3 nuts that secure the motor mounting bracket to the chassis.
12. Reconnect the auger motor 4-pin connector to the machine wiring harness.

Part Removal and Replacement:

1. Disconnect the dispenser from the power source.
2. Locate the auger motor 4-pin connector, push-in the connector tab to release connector from the machine wiring harness.

NOTE: When removing or installing the motor be sure the split pin in the motor shaft is turned to a position that will clear the torque sensor circuit board.
3. Use a 7/16" nut driver or deep well socket to remove the 3 nuts securing the auger motor bracket to the chassis.
4. Grab the auger motor with mounting bracket and begin pulling motor away from auger shaft being careful that the motor .188 pin clears the board sensor.
5. Remove 1 screw and washer holding torque sensor circuit board into drum housing slot.
6. Gently remove torque sensor board from drum housing slots. See FIG. 15.
7. Disconnect 3-pin wire harness connector from the torque sensor board and discard.
8. Reconnect machine wiring 3-pin connector onto replacement torque sensor circuit board.
9. Install replacement torque sensor into drum housing slots and secure with 1 screw and washer from step 5.
10. Being careful, reinstall auger motor with bracket, engaging the motor shaft into the auger shaft torsion springs.

SERVICE - REAR COVER COMPONENTS

Left and Right PTC Heater

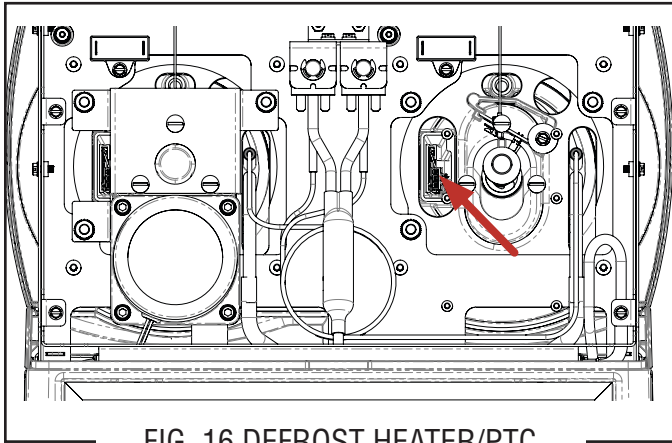


FIG. 16 DEFROST HEATER/PTC

Location:

The defrost heater is located inside a slot at the rear of each cooling drum assembly. The defrost heater is covered over with pipe insulating cork tape.

NOTE: The above pictorial has one auger motor hidden to show location of a defrost heater.

Rear Cover Removal:

1. Remove 4 screws securing rear cover.
2. Grab cover and pull away from machine.

Test Procedures:

NOTE: Going to check cooling drum defrost heater for real time temperature change by feel and real time temperature reading in software program test menu.

1. Drain hopper and wipe down cooling drum being checked.
2. Enter the software program and scroll to main "Service Tools" menu.
3. Press the "Right Dot" switch to answer "Yes".
4. Press the "Center Dot" switch to advance onto "Test Outputs" menu.
5. Press the "Right Dot" switch to answer "Yes".
6. Press the "Center Dot" switch to scroll through the menus until "LEFT PTC 74°" menu is displayed.

NOTE: The "LEFT PTC 74°" menu will allow the operator or technician to test the operation of the defrost heater while displaying real time cooling drum temperature on the upper right corner of the test menu.

7. Place hand on the rear right side of the cooling drum and feel for temperature change when you turn on the defrost heater in the next step.
8. Press the "Left Dot" switch to answer "ON". The defrost heater is turned on, wait approximately 1 minute for temperature to change 1 degree on the display or feel the temperature change on the cooling drum.

No temperature change, check defrost heater/PTC for power before replacing defrost heater/PTC.

Yes temperature increases, defrost heater/PTC is good.
9. Press the "Center Dot" switch to advance onto "RIGHT PTC 74°" menu.
10. Repeat steps 7 & 8 to verify operation of Right Defrost Heater/PTC.

Defrost Heater/PTC Ratings

Ultra NX 120V Models:

Heater Assembly, PTC 120V ULTRA NX

RESISTANCE: 350-450 OHMS

VOLTAGE: 120VAC

Ultra NX 200-240V Models:

Heater Assembly, PTC 230V ULTRA NX

RESISTANCE: 500-600 OHMS

VOLTAGE: 230VAC

SERVICE - REAR COVER COMPONENTS

Left and Right PTC Heater



FIG. 17 DEFROST HEATER/PTC

Part Removal and Replacement:

1. Disconnect the dispenser from the power source.
2. Locate the auger motor 4-pin connector, push-in the connector tab to release connector from the machine wiring harness.

NOTE: When removing or installing the motor be sure the split pin in the motor shaft is turned to a position that will clear the torque sensor circuit board.

3. Use a 7/16" nut driver or deep well socket to remove the 3 nuts securing the auger motor bracket to the chassis.
4. Grab the auger motor with mounting bracket and begin pulling motor away from auger shaft being careful that the motor .188 pin clears the board sensor.
5. Pull insulating pipe cork tape away that is covering the defrost heater and set aside.
6. Disconnect the defrost heater 3 pin connector from the machine wiring harness.
7. Locate and grab the defrost heater spring clip, pull on the spring clip to remove defrost heater from drum housing. See FIG. 17 & 18.

NOTE: A little force may be needed to pull defrost heater because the spring clip acts as wedge to keep defrost heater firmly in position.

8. Before installation of replacement defrost heater, ensure the heat sink compound is evenly distributed over the defrost heater surface that is going to be in direct contact with the drum housing.

9. Facing the rear cooling drum, position the surface with the heat sink compound on the defrost heater assembly to the left and begin pushing the heater all the way into the housing until it stops.
10. Reconnect the defrost heater 3-pin connector to the machine wiring harness.
11. Reuse or use new insulating pipe cork tape to cover the defrost heater.

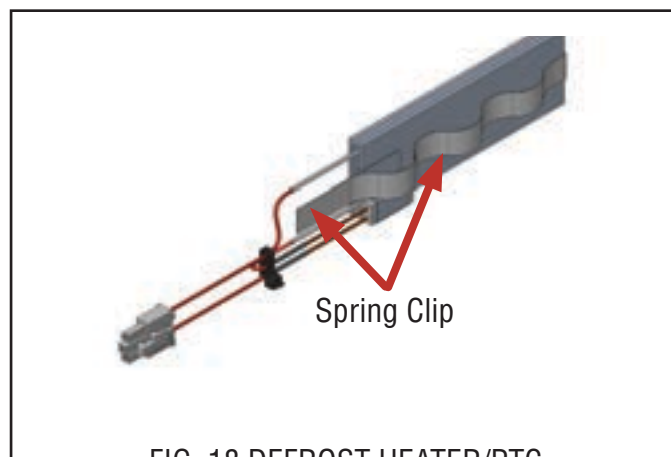


FIG. 18 DEFROST HEATER/PTC

SERVICE - REAR COVER COMPONENTS

Left and Right Cooling Drum Temperature Sensor

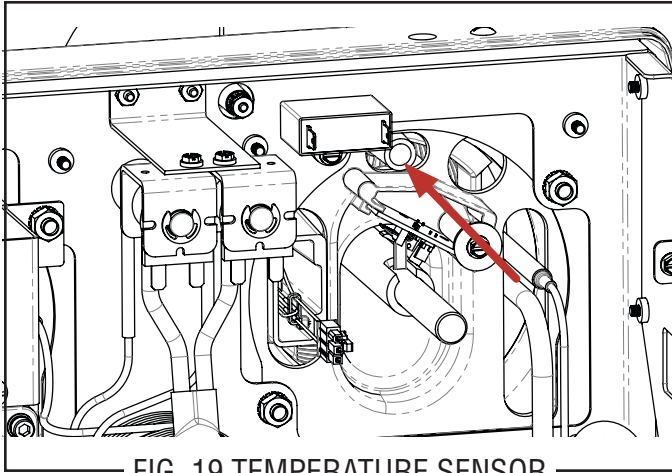


FIG. 19 TEMPERATURE SENSOR

Location:

The Cooling Drum Temperature Sensor(s) are located inside the top rear of the cooling drum housing behind the Auger Motor cover.

Rear Cover Removal:

1. Remove 4 screws securing rear cover.
2. Grab cover and pull away from machine.

Test Procedures:

NOTE: Each cooling drum real time temperature can be viewed by accessing the program real time status menu by simultaneously pressing and holding Left & Right Dot for 5 seconds to display the TEMP & TORQUE screen. The temperature of each cooling drum and the hot gas temperature can be seen.

Voltage Check

1. Connect a voltmeter, across the two leads of the temperature sensor (leave plug connected);

The indication must be:

- a) Approximately 2.6 vdc @ 32° F
- b) Approximately 1.4 vdc @ 71° F

If voltage reading is 0v, the Control Board is not supplying the necessary 5v and should be replaced. If the reading stays at 5vdc, replace thermistor.

Resistance Check

2. Disconnect the plug on thermistor leads and check resistance as indicated below.

The indication must be within range of known temperature:

- a) 1,473 - 1,614 ohms @ 32° F
(Water with Ice)
- b) 394 - 454 ohms @ 71° F
(Room Temperature)

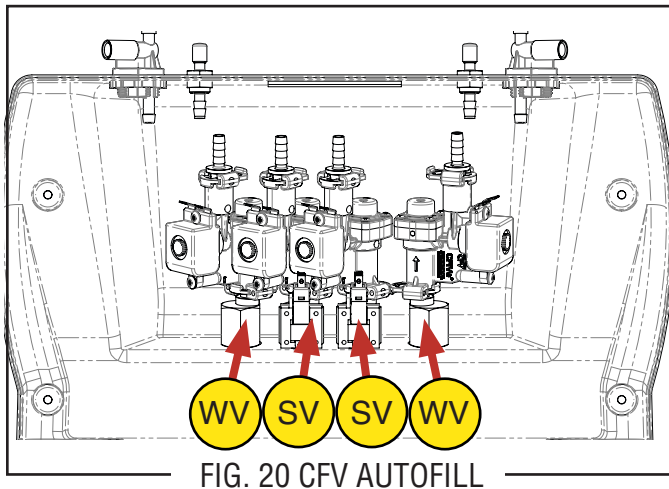
If resistance reading is not within the range listed above, replace thermistor.

Part Removal and Replacement:

1. Disconnect the dispenser from the power source.
2. Locate the temperature sensor 2-pin connector, push-in the connector tab to release temperature sensor connector from the machine wiring harness.
3. Pull the insulating pipe cork tape away from the temperature sensor.
4. Grab temperature sensor wires and begin gently pulling temperature sensor out of housing. See FIG. 19.
5. Install replacement temperature sensor into housing and push the sensor all the way until it stops (approximately 10.50 inches).
6. Reconnect temperature sensor 2-pin connector to machine wiring harness.
7. Reseal insulating pipe cork tape around the inlet and temperature sensor wires to seal and hold sensor in position.

SERVICE - REAR COVER COMPONENTS

CF CFIVE Solenoid Valves - CFV/Autofill



Location:

Inside the auger motor cover, four CFV CFIVE assemblies are present. Two for Water (no orifice) and two for Syrup (with orifice).

WV: Water CF CFIVE Solenoid Valve Assy

SV: Syrup CF CFIVE Solenoid Valve Assy with Pressure Switch

Rear Cover Removal:

1. Disconnect power from machine.
2. Lift hopper cover to remove dual inlet fitting from hopper.
3. Remove 4 screws securing rear cover.
4. Grab cover with water and syrup line still connected to the inlet barb fitting and gently pull cover away from machine.

Test Procedure:

NOTE: The Dual Inlet Hopper Fitting is removed from hopper during this Valve Test Procedure to prevent any unwanted mix ratio entering already ratio'd product in hopper.

If hopper is empty of product, test can be performed on valve assemblies with Dual Inlet Hopper Fitting still installed on empty hopper.

1. Ensure Dual Inlet Fitting removed from hopper and/or use of temporary extension lines are put inside an empty bucket for the purpose of checking the flow of water and syrup from the valve assemblies.
2. Enter the software program and scroll to main "Auto Refill" menu.
3. Press the "Right Dot" switch to answer "Yes".

4. Press the "Center Dot" switch to advance onto "Test Refill" menu.
5. Press the "Right Dot" switch to answer "Yes" to advance onto "Left Refill Valve" menu.
6. Press the "Left Dot" switch to answer "ON". The Left Refill Valves will energize to allow water and syrup flow, press "OFF" by pressing the "Right Dot" to stop test.
7. Press the "Center Dot" to advance onto "Right Refill Valve" menu.
8. Press the "Left Dot" switch to answer "ON". The Right Refill Valves will energize to allow water and syrup flow, press "OFF" by pressing the "Right Dot" to stop test.

If you hear a click sound or feel the magnetic pull on top of the solenoid valve coil, the control board output is operating correctly. If the water or syrup fails to flow, check the CO₂ source for adequate supply pressure (40 - 80psig) to operate the CO₂ pump and inlet water pressure within the 30 - 80psig requirement.

No click sound or magnetic pull, check valve coil for control board output voltage to determine failure between control board or CF CFIVE solenoid valve.

No power across valve coil - replace control board.

Yes power across valve coil- replace CFV CFIVE solenoid valve.

Electrical Rating:

Ultra NX 120V Models:

CFV CFIVE Solenoid Valve: 24VDC

Ultra NX 200-240V Models:

CFV CFIVE Solenoid Valve: 24VDC

SERVICE - REAR COVER COMPONENTS

CF CFIVE Solenoid Valves - CFV/Autofill

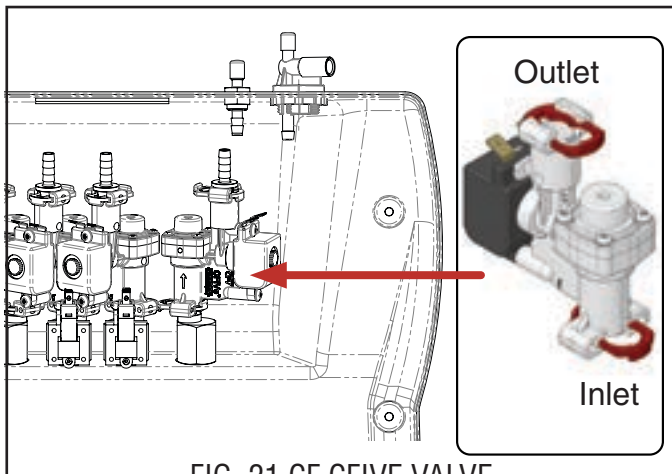


FIG. 21 CF CFIVE VALVE

11. Turn on the water and bag-in-box source supply.
12. Reconnect machine to power supply.

NOTE: Check operation and inspect for leaks.

Part Removal and Replacement:

NOTE: Removal and replacement instruction below can be used for the water or syrup CF CFIVE solenoid valve.

1. Disconnect power supply from the machine.
2. Shut off the main water and bag-in-box source supply.
3. Locate the CF CFIVE solenoid valve being replaced.
4. Disconnect the top outlet fitting from solenoid valve base by moving the red lock clip to release outlet fitting with hose, lift fitting out of valve base.
5. Unlock the lower valve inlet by moving the red lock clip to release CF CFIVE solenoid valve from lower mount CFIVE fitting.
6. Disconnect wires from solenoid valve coil terminals.
7. Lift CF CFIVE solenoid valve from lower mount fitting and discard.
8. Install replacement CF CFIVE onto lower mount fitting and secure by moving the red lock clip into lock position.
9. Insert outlet fitting with tube back into CF CFIVE outlet hole and secure by moving the red lock clip into lock position.
10. Reconnect wires to the solenoid valve coil terminals.

SERVICE - REAR COVER COMPONENTS

Left and Right Pressure Switch - CFV/Autofill

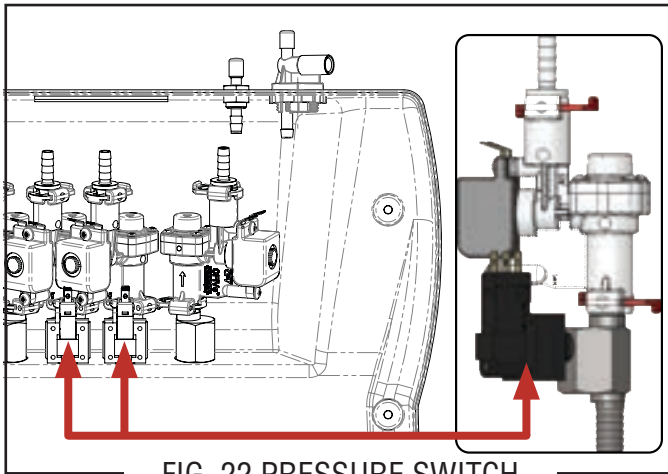


FIG. 22 PRESSURE SWITCH

Location:

Inside the auger motor cover, the pressure switch is mounted on the two center syrup CFV CFIVE assembly inlet fittings.

Rear Cover Removal:

1. Disconnect power from machine.
2. Lift hopper cover to remove dual inlet fitting from hopper.
3. Remove 4 screws securing rear cover.
4. Grab cover with water and syrup line still connected to the inlet barb fitting and gently pull away from machine.

Test Procedures:

NOTE: Ensure the CO₂ supply is adequate and properly adjusted to a regulated pressure range between 40 - 80psig. A typical set point is 65psig.

1. Enter the software program and scroll to main "Auto Refill" menu.
2. Press the "Right Dot" switch to answer "Yes".
3. Press the "Center Dot" switch to advance onto "L Pressure R" menu.
4. The bottom line on the display will indicate the pressure status for Left & Right hopper as being "Good" or "Low".

If the supply CO₂ and pressure setting is within the 40 - 80psig range and the status reads "Low", note the position of the wires on the pressure switch terminals before replacing the pressure switch.

NOTE: Switch is wired to the normally open terminal.

If the supply CO₂ and pressure setting is adequate and the status reads "Good" on left and right side, but no operation of the water and syrup valve to deliver product, check and make sure the "Auger Refill On" circuit is activated by toggling the corresponding left or right "Auger" button on the User Panel until "Auger Refill On" is displayed on that side to operate refill feature.

If the supply CO₂ is empty or low, pressure is out of the required 40 - 80psig range and the "L Pressure R" menu reads "Low", follow location procedure "changing out portable CO₂ tank" and/or notify location manager being out of CO₂ supply.

Part Removal and Replacement:

1. Disconnect power supply from the machine.
2. Shut off the main water and bag-in-box source supply.
3. Locate the syrup CF CFIVE solenoid valve pressure switch being replaced.
4. Unlock the lower valve inlet by moving the red lock clip to release CF CFIVE solenoid valve from lower mount CFIVE fitting.
5. Remove one screw securing the lower mount CF CFIVE fitting to the cover.
6. Note the location of wires on the pressure switch terminals before disconnecting them from the pressure switch.
7. Unscrew the pressure switch from the fitting.
8. Install thread sealant onto the replacement pressure switch threads.
9. Reinstall pressure switch into CF CFIVE mount fitting.
10. Install CF CFIVE mount fitting with pressure switch back into position and secure with screw.
11. Reinstall CF CFIVE onto lower mount fitting and secure by moving the red lock clip into lock position.
12. Reinstall wires onto pressure switch terminals.
13. Turn on the water and bag-in-box source supply.
14. Reconnect machine to power supply.

NOTE: Check operation and inspect for leaks.

SERVICE - REAR COVER COMPONENTS

CF CFIVE Solenoid Valves - LAF/Autofill

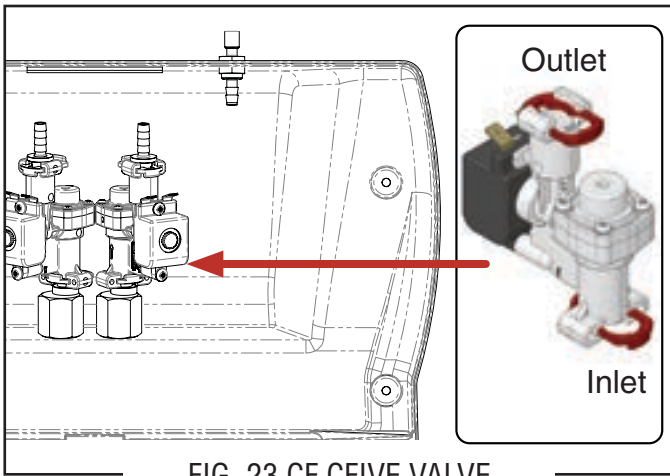


FIG. 23 CF CFIVE VALVE

Location:

Inside the auger motor cover, two CF CFIVE solenoid valve assemblies are present.

WV: Water CF CFIVE Solenoid Valve Assembly

Description:

The LAF system is designed to use an external Ratio Brix Proportioning Pump that is driven by pressurized water, allowing the water and product to be delivered at an exact ratio. When a Bag-in-Box (B-I-B) container is used, a vacuum shut-off is needed on the Ratio Brix pump. The pump will automatically stop operation, when the concentrate bag is completely evacuated, by closing off the inlet water. When a new B-I-B is installed, the pump will automatically resume operation without the need to prime the system. See "BRIX Pump (Autofill) Installation" illustration.

Rear Cover Removal:

1. Disconnect power from machine.
2. Lift hopper cover to remove dual inlet fitting from hopper.
3. Remove 4 screws securing rear cover.
4. Grab cover with water line still connected to the inlet barb fitting and gently pull cover away from machine.

Test Procedure:

NOTE: The Dual Inlet Hopper Fitting is removed from hopper during this Valve Test Procedure to prevent any unwanted mix ratio entering already ratio'd product in hopper.

If hopper is empty of product, test can be performed on valve assemblies with Dual Inlet Hopper Fitting still installed on empty hopper.

1. Ensure Dual Inlet Fitting removed from hopper and/or use of temporary extension lines are put inside an empty bucket for the purpose of checking the flow of water and syrup.
2. Enter the software program and scroll to main "Auto Refill" menu.
3. Press the "Right Dot" switch to answer "Yes".
4. Press the "Center Dot" switch to advance onto "Test Refill" menu.
5. Press the "Right Dot" switch to answer "Yes" to advance onto "Left Refill Valve" menu.
6. Press the "Left Dot" switch to answer "ON". The Left Refill Valve will energize to allow water and syrup flow, press "OFF" by pressing the "Right Dot" to stop test.
7. Press the "Center Dot" to advance onto "Right Refill Valve" menu.
8. Press the "Left Dot" switch to answer "ON". The Right Refill Valve will energize to allow water and syrup flow, press "OFF" by pressing the "Right Dot" to stop test.

If you hear a click sound or feel the magnetic pull on top of the water solenoid valve coil, the control board output is operating correctly. If the water or syrup fails to flow, reference the Brix Pump manufacture manual regarding Troubleshooting the Brix Pump.

No click sound or magnetic pull, check valve coil for power.

No power across valve coil - replace control board.

Electrical Rating:

Ultra NX 120V Models:

CFV CFIVE Solenoid Valve: 24VDC

Ultra NX 200-240V Models:

CFV CFIVE Solenoid Valve: 24VDC

SERVICE - REAR COVER COMPONENTS

CF CFIVE Solenoid Valves - LAF/Autofill

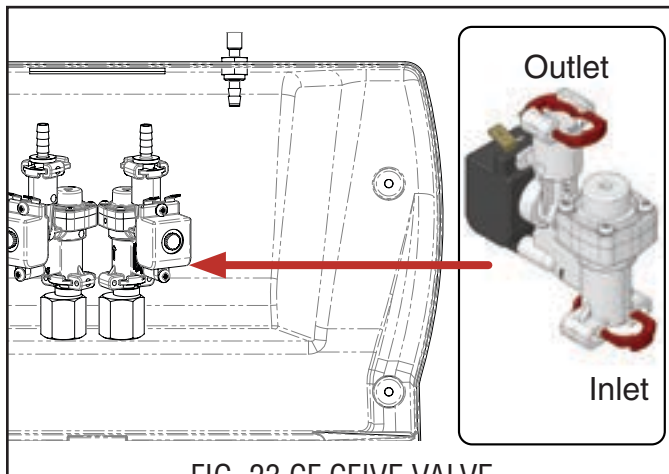


FIG. 23 CF CFIVE VALVE

Part Removal and Replacement:

1. Disconnect power supply from the machine.
2. Shut off the main water to the external Brix Proportional Pump
3. Locate the CF CFIVE solenoid valve being replaced.
4. Disconnect the top outlet fitting from solenoid valve base by moving the red lock clip to release outlet fitting with hose, lift fitting out of valve base.
5. Unlock the lower valve inlet by moving the red lock clip to release CF CFIVE solenoid valve from lower mount CFIVE fitting.
6. Disconnect wires from solenoid valve coil terminals.
7. Lift CF CFIVE solenoid valve from lower mount fitting and discard.
8. Install replacement CF CFIVE onto lower mount fitting and secure by moving the red lock clip into lock position.
9. Insert outlet fitting with tube back into new CF CFIVE outlet hole and secure by moving the red lock clip into lock position.
10. Reconnect wires to the solenoid valve coil terminals.
11. Turn on the water supply to the Brix Proportioning Pump.
12. Reconnect machine to power supply.

NOTE: Check operation and inspect for leaks.

SERVICE - REAR COVER COMPONENTS

Left and Right Refrigerant Solenoids

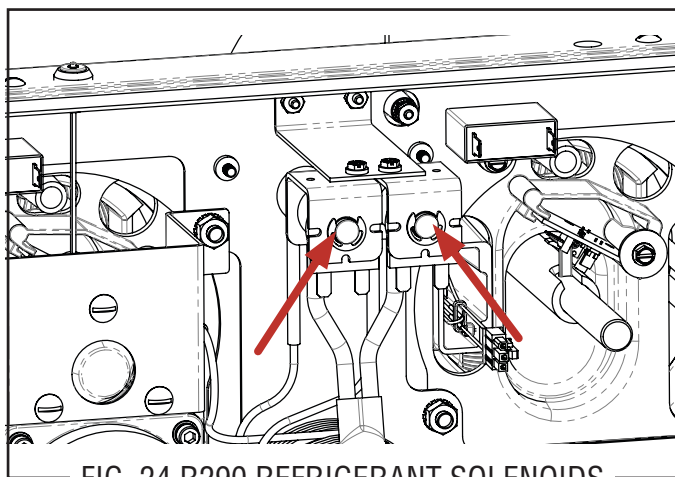


FIG. 24 R290 REFRIGERANT SOLENOIDS

Location:

The refrigerant solenoids are mounted on a bracket that is attached in the rear between the auger motors behind the Auger Motor cover.

WARNING: Before repair and/or removal of any refrigeration component must be performed by a trained and licensed R-290 repair technician.

Rear Cover Removal:

1. Remove 4 screws securing rear cover.
2. Grab cover and pull away from machine.

Test Procedures:

NOTE: The "TestRefrigValve" menu will allow the technician to test the operation of the solenoid coil and/or output of the main control board.

1. Enter the software program and scroll to main "Service Tools" menu.
2. Press the "Right Dot" switch to answer "Yes".
3. Press the "Center Dot" switch to advance onto "Test Outputs" menu.
4. Press the "Right Dot" switch to answer "Yes".
5. Press the "Center Dot" switch to scroll through the menus until "TestRefrigValve" menu is displayed.
7. Press the "Right Dot" switch to answer "Yes" to advance onto "Left RefrigValve" menu.
8. Press the "Left Dot" switch to answer "ON". "Left RefrigValve" will energize (click sound).
9. Press the "Center Dot" to advance onto "Right RefrigValve" menu.
10. Press the "Left Dot" switch to answer "ON". "Right RefrigValve" will energize (click sound).

If you hear a click sound or feel the magnetic pull on top of the solenoid coil, the control board output is operating correctly. If the cooling drum fails to get cold and/or weak layer of frost on the cooling drum, indicates a possible low refrigerant charge or blockage within the refrigerant solenoid valve.

WARNING: Part Removal and Replacement:

This will require a trained and licensed R-290 technician to make the necessary repair of the R-290 refrigeration system.

R290 Solenoid Valve Ratings:

Ultra NX 120V Models:

Solenoid Valve: 120VAC/60HZ-110VAC/50HZ

Ultra NX 200-240V Models:

Solenoid Valve: 240VAC/60HZ-220VAC/50HZ

11. Connect a voltmeter across the white wire and the other wire on the solenoid coil being tested. Repeat steps 8 thru 10.

NOTE: The voltage output from the control board must be checked with load (solenoid coil) connected.

If the control board voltage output is not present on the refrigerant solenoid valve coil, replace the main control board.

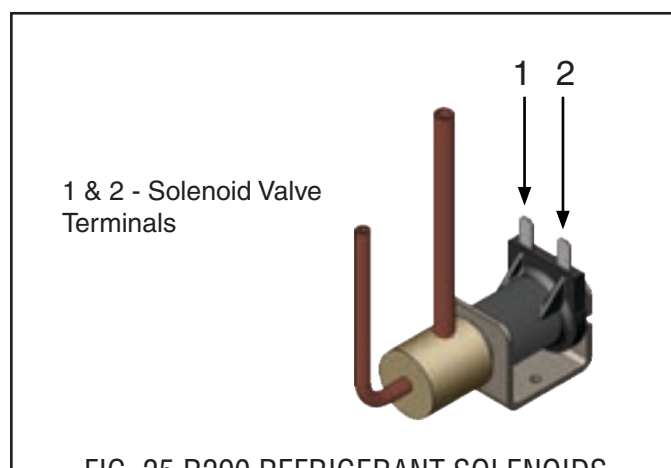


FIG. 25 R290 REFRIGERANT SOLENOIDS

SERVICE - REAR COVER COMPONENTS

Left and Right Auger Shaft Assembly

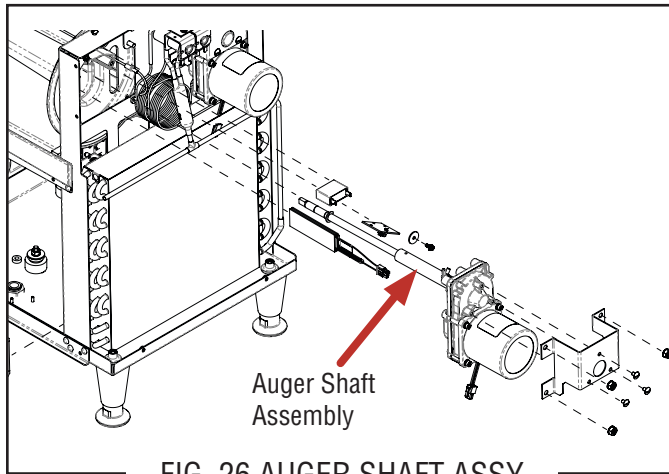


FIG. 26 AUGER SHAFT ASSY

Location:

The Auger Shaft Assembly is located in each of the cooling drums.

Rear Cover Removal:

1. Remove 4 screws securing rear cover.
2. Grab cover and pull away from machine.

Test Procedures:

NOTE: The condition of the auger shaft torsion springs can be viewed by utilizing the machine software

informational screen called “Display Temp & Torque” menu. Torsion springs can become weak or damaged because of improper mixing of product or become weak over a long period of usage/operation.

The left or right number on the screen is a real time operation number (torque) related to the “Thickness” setting multiplied by three during normal auger load (slushy product or chilled product) auger rotation or no load (empty hopper) auger rotation.

1. Enter the software program and press the “Right DOT” switch to answer “Yes” under the “Daily Operations” menu.
2. Press the “Center Dot” switch to advance to “Set Thickness” menu.
3. Press the “Right Dot” switch to enter “Left Thickness” setting menu. Record left thickness setting number. Press “Center Dot: advance onto “Right Thickness” setting menu. Record right thickness setting number.

4. Exit software program.
5. Press and hold “Left & Right Dot” simultaneously for 5 seconds to enter the “Display Temp & Torque” screen. See FIG. A.

NOTE: The informational screens will automatically toggle back and forth.

6. The left and right torque number will be displayed in real time during auger rotation. The auger can be under no load (empty) or under load (rotating slush) in the hopper. See FIG. B.
7. If the left or right hopper is empty and technician presses the user panel left auger button to turn on the left auger (rotation), the thickness number recorded in step 3 multiplied by 3 is the number that will be represented on the top left line of the display. The number will count down during auger rotation and should achieve zero on the display.

If the auger torque number does not achieve zero (0) during auger no load rotation and stops at a relative higher number than zero, like 6, that is an indication of possible weak torsion springs within the auger shaft.

8. If the left and right hopper are rotating slush product, the technician can view the left & right torque number in real time to see if the product is still refrigerating to achieve product “Thickness” setting for that side.

Example: Right Thickness is set at 10.

$$10 \times 3 = 30$$

The right refrigerant valve Off point will be 30 plus 1.

The torque/load number will increase until 31 has been reached, product is ready for consumption.

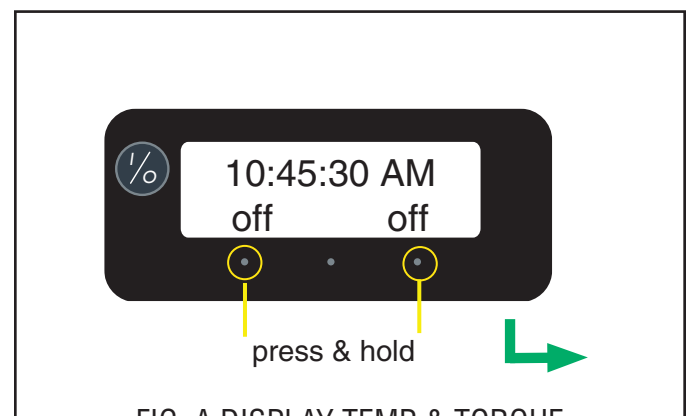


FIG. A DISPLAY TEMP & TORQUE

SERVICE - REAR COVER COMPONENTS

Left and Right Auger Shaft Assembly

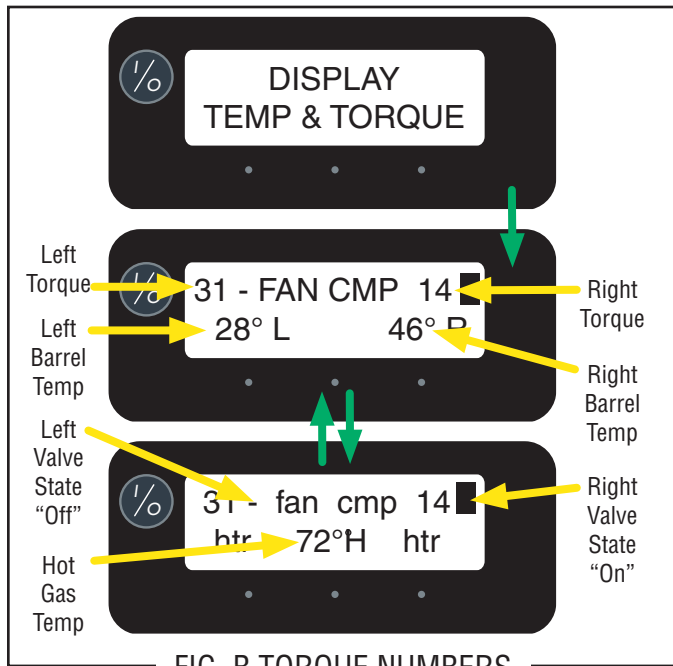


FIG. B TORQUE NUMBERS

Small Block (-): Left or Right Refrigerant Solenoid is OFF

Large Block (■): Left or Right Refrigerant Solenoid is ON

Lower case fan: Means condenser fan is not operating.

Upper case FAN: Means condenser fan is powered and operating.

Lower case cmp: Means compressor is not operating.

Upper case CMP: Means compressor is powered and operating.

Lower case htr: Means the PTC heater is off.

Upper case HTR: Means the PTC heater is on.

The left or right number (currently showing 31 & 14) is a real time operation number (torque) related to the Thickness setting which is multiplied by three.

Part Removal and Replacement:

1. Drain, remove and clean hopper; refer to the Recommended Daily Weekly Cleaning Section of the Installation & Operating manual, for proper cleaning procedures.
2. Disconnect the dispenser from the power source.
3. Locate the auger motor 4-pin connector, push-in the connector tab to release connector from the machine wiring harness.

NOTE: When removing or installing the motor be sure the split pin in the motor shaft is turned to a position that will clear the position sensor (torque) circuit board.

4. Use a 7/16" nut driver or deep well socket to remove the 3 nuts securing the auger motor bracket to the chassis.
5. Grab the auger motor with mounting bracket and begin pulling motor away from auger shaft

being careful that the motor .188 pin clears the board sensors. Set motor aside.

6. Rotate shaft so the shaft .188 pin clears the sensor board. Next, pull the auger shaft backward until the shaft assembly is totally out of the cooling drum.
 7. Before installation of a replacement auger shaft assembly, absolutely recommended to change front cooling drum shaft seal and blue bushing.
 8. From the front of dispenser, remove the seal and blue bushing from cooling drum and discard them.
 9. Clean seal and bushing surfaces of the cooling drum very thoroughly. FIG. 28
 10. Insert new blue bushing into cooling drum hole.
 11. Place seal on insertion tool #37593.00001 or insert seal by hand with tabs facing outward. FIG. 28.
 12. Push seal into cooling drum hole until it is firmly seated against the blue bushing; remove tool. FIG. 28.
 13. Place a small amount lubrifilm lubricant on the ceramic surface area of the replacement auger shaft before reinstallation. FIG. 27
 14. Insert the replacement auger shaft into the rear of the cooling drum, rotate shaft so pin will clear torque board sensors and push shaft all the way in until it passes through the new front seal.
- NOTE: Before reinstallation of motor assembly, ensure a small amount of Krytox grease (M2548.1000) is present on the torsion spring bearing that will engage the auger shaft torsion springs.
15. Being carefull, install motor with bracket, engaging the motor shaft into the auger shaft torsion springs.
 16. Reinstall the 3 nuts that secure the motor mounting bracket to the chassis.
 17. Reconnect the auger motor 4-pin connector to the machine wiring harness.

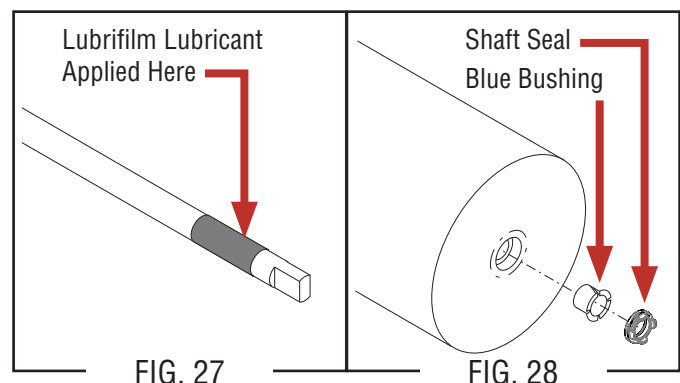


FIG. 27

FIG. 28

SERVICE - LEFT SIDE PANEL COMPONENTS

Refrigeration Hot Gas Temperature Sensor

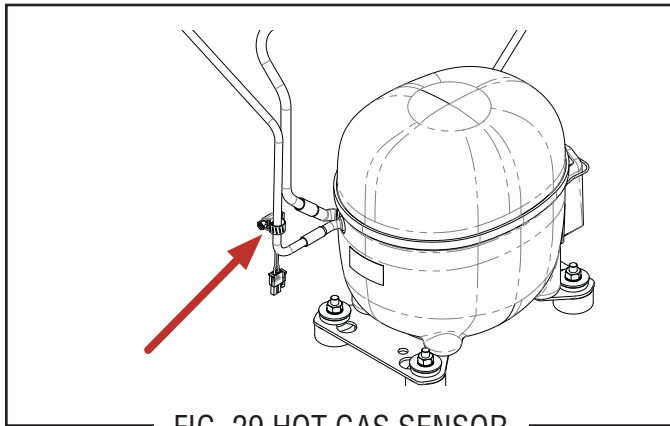


FIG. 29 HOT GAS SENSOR

Location:

The Hot Gas Sensor is located behind the left side panel and secured to the Compressor-to-Condenser hot gas tube.

Left Panel Removal:

1. Loosen 2 left side panel screws on the underside of the machine.
2. Grab and lower the left panel while pulling the bottom outward to remove panel.
3. If needed, repeat steps for right side panel.

Test Procedures:

NOTE: The Hot Gas Line temperature can be viewed by accessing the program real time status menu by simultaneously pressing and holding Left & Right Dot for 5 seconds to display the TEMP & TORQUE screen. The Hot Gas temperature can be seen on the informational screen, second row in the center.

Voltage Check

1. Remove the left side housing panel.
2. Connect a voltmeter, across the two leads of the hot gas sensor (leave plug connected);

The indication must be:

- a) Approximately. 4.0 vdc @ 37° F
- b) Approximately. 3.4 vdc @ 82° F

If voltage reading is 0v, the Control Board is not supplying the necessary 5v and should be replaced. If the reading stays at 5vdc, replace the hot gas sensor.

Resistance Check

3. Disconnect the plug on the hot gas sensor leads from the connector on the main harness.
4. Connect an ohmmeter across the two leads of the hot gas sensor;

The indication must be within range of known temperature:

a) 7,216 - 7,574 ohms @ 32° F.
(Water with Ice)

b) 1,617 - 1,769 ohms @ 71° F.
(Room Temperature)

See FIG. 30.

If resistance reading is not within the range listed above, replace sensor.

Part Removal and Replacement:

1. Remove the left side housing panel.
2. Disconnect the plug on the hot gas sensor leads from the connector on the main harness.
3. Remove the clamp securing the hot gas sensor to Compressor-to-Condenser tube.
4. Securing the replacement hot gas sensor to Compressor-to-Condenser tube using the clamp previously removed.
5. Refer to Fig. 29 & 30 and plug the new sensor into the connector on the main harness.

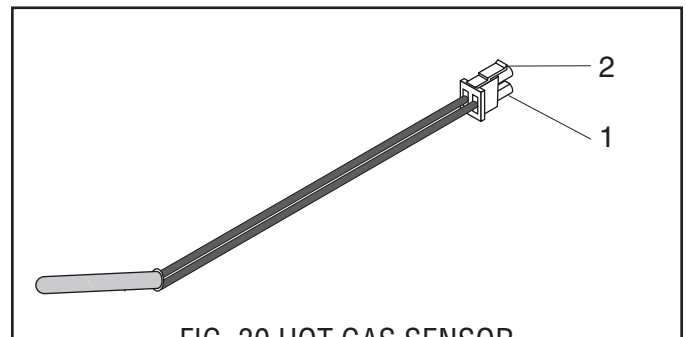


FIG. 30 HOT GAS SENSOR

SERVICE - LEFT SIDE PANEL COMPONENTS

Condenser Fan Assembly

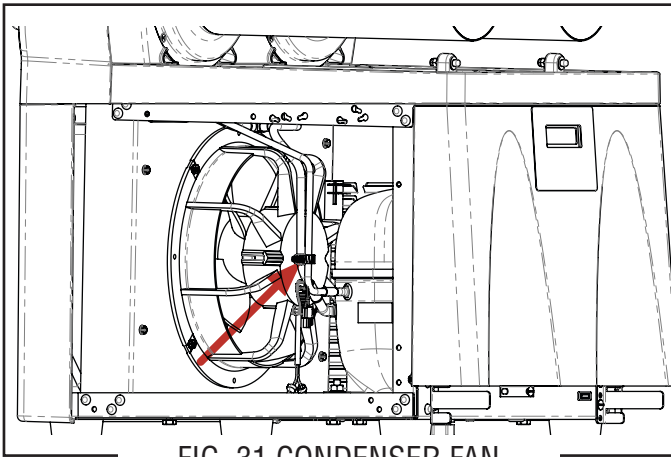


FIG. 31 CONDENSER FAN

Location:

The fan is located inside the dispenser chassis just in front of the condenser.

Left Panel Removal:

1. Loosen 2 left side panel screws on the underside of the machine.
2. Grab and lower the left panel while pulling the bottom outward to remove panel.
3. If needed, repeat steps for right side panel.

Test Procedures:

1. Enter the software program and scroll to main "Service Tools" menu.
3. Press the "Right Dot" switch to answer "Yes".
4. Press the "Center Dot" switch to advance onto "Test Outputs" menu.
5. Press the "Right Dot" switch to answer "Yes".
6. Press the "Center Dot" switch to scroll through the menus until "Fan Condenser" menu is displayed.

NOTE: The "Fan Condenser" menu will allow the operator or technician to test the operation of the fan or and/or voltage output from the main control board.

7. Press the "Left Dot" switch to answer "ON". Fan should operate.

No fan operation, check fan for output voltage from the control board

8. Press the "Right Dot" switch to answer "Off".
9. Disconnect the condenser fan motor spade terminals from the machine wiring harness.
10. Check for voltage across the machine wiring harness spade terminals that were connected to the fan terminals when you turn "On" fan.
11. Press the "Left Dot" switch to answer "ON". Voltage should be present.
12. Press the "Right Dot" switch to answer "Off".

NOTE: Power output to the condenser fan is 120V or 230V depending upon the model.

No voltage present - replace control board.

Yes voltage present - fan does not operate, replace fan.

Condenser Fan Specifications:

Ultra NX 120V Models:

VOLTAGE: 115VAC/50-60HZ

MAX INPUT POWER: 31W

AMPERAGE: .46A

SPEED: 2100 ±100 RPM

Ultra NX 200-240V Models:

VOLTAGE: 230VAC/50-60HZ

MAX INPUT POWER: 31W

AMPERAGE: .24A

SPEED: 2100 ±100 RPM

Part Removal and Replacement:

1. With left and right side panels removed, go to the right side and disconnect the condenser fan motor spade terminals from the machine wiring harness.
2. Go to the left side, remove 4 nuts securing fan assembly to the machine frame. Retain nuts.
3. Remove the condenser fan assembly out the left side and discard.
4. Reinstall replacement condenser fan assembly and secure with the retained 4 nuts.
5. Reconnect fan spade terminals to the machine wiring harness terminals.

SERVICE - RIGHT SIDE PANEL COMPONENTS

Compressor Relay

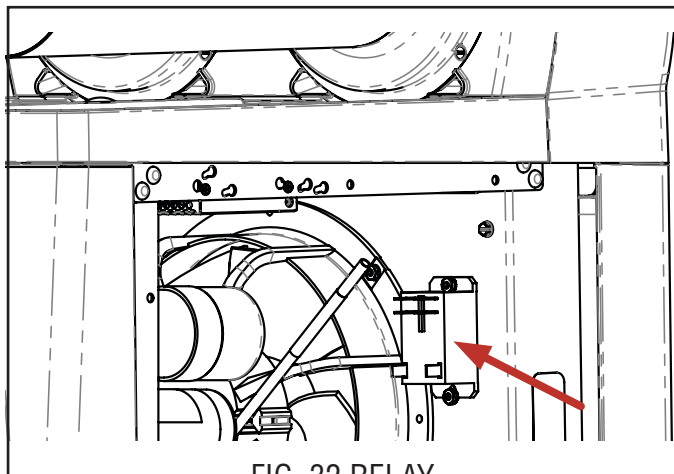


FIG. 32 RELAY

Location:

The relay is located inside the dispenser chassis just to the right of the condenser fan.

Right Panel Removal:

1. Loosen 2 right side panel screws on the underside of the machine.
2. Grab and lower the right panel while pulling the bottom outward to remove panel.

Test Procedures:

NOTE: The “Compressor Test” menu will allow the technician to test the operation of the relay coil to ensure power is switched across the relays contacts and onto the compressor start up circuit.

1. Enter the software program and scroll to main “Service Tools” menu.
2. Press the “Right Dot” switch to answer “Yes”.
3. Press the “Center Dot” switch to advance onto “Test Outputs” menu.
4. Press the “Right Dot” switch to answer “Yes”.
5. Press the “Center Dot” switch to scroll through the menus until “Compressor Test” menu is displayed.
6. Press the “Right Dot” switch to answer “Yes” to advance onto “Compressor” menu.
7. Press the “Left Dot” switch to answer “ON”. “Compressor” will operate.
No compressor operation, continue with testing procedure.
8. Check relay coil for 24VDC during “Compressor” test. See FIG. 33.

No 24VDC across relay coil terminals, replace control board.

Yes 24VDC across relay coil terminals, continue with testing steps.

9. Disconnect dispenser power to remove wires from the relay normally open contact terminals.
10. Next, adjust meter to read continuity. Place leads across relay contact/terminals. Must read no continuity until you turn On “Compressor” outlined in steps 1 thru 7. See. FIG 33.
11. Press the “Left Dot” switch to answer “ON”. “Compressor” relay contact terminals should switch from an open position (no continuity) to a closed position (continuity). Meter will sound an audible alarm or show 0.00 on the display to indicate continuity.

No continuity across relay contacts during test, replace relay.

Relay Rating:

CONTACTS: SPST-NO 30A @ 400VAC

COIL: 24VDC

(OPERATE: 2.4-18VDC, 350 OHMS, 1.7W)

Part Removal and Replacement:

1. Disconnect power from machine.
2. Note the color of wire to each terminal on the relay before disconnecting the wires from the relay terminals.
3. Remove 2 nuts securing the relay to the machine frame. Discard relay.
4. Install replacement relay and secure with the 2 nuts.
5. Reconnect the wires to the relay terminals.



FIG. 33 RELAY

SERVICE - RIGHT SIDE PANEL COMPONENTS

Power Supply

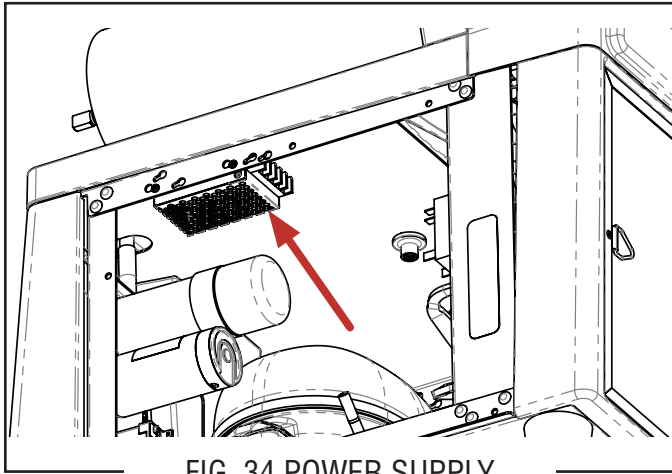


FIG. 34 POWER SUPPLY

Location:

Only one power supply is located behind right side panel and mounted to the side frame above the capacitors. Power supply could be BUNN Part Number [33363.0013](#), [33363.0014](#) or [33363.0019](#).

Right Panel Removal:

1. Loosen 2 right side panel screws on the underside of the machine.
2. Grab and lower the right panel while pulling the bottom outward to remove panel.

Test Procedures:

NOTE: The power supply accepts incoming 100-240VAC and steps down and converts the voltage to a 24VDC output. The power supply has an LED power indicator.

1. Check power supply L & N terminals for incoming AC power. See FIG. 35 or 36.
No AC power or power LED illumination, check power source for power before replacing power supply.
Yes AC power on L & N power supply terminals.
2. Check the Output terminals (-V & +V) on the power supply for 24VDC.
No DC power, replace power supply.

Part Removal and Replacement:

1. Disconnect power supply to the machine.
2. With right side panel removed, locate the power supply.
3. Loosen 2 key lock screws securing power supply to the machine frame.

4. Pull power supply with screws out of the machine key holes. Finish removing the screws from power supply and retain screws.
5. Note the position of wire/colors on the power supply terminals.
6. Disconnect wires from the power terminals. discard power supply.
7. Install screws retained in step 4 into the replacement power supply.
8. Reconnect wires to the power supply terminals.
NOTE: Ensure green jumper wire is installed in the labeled "Ground and -V" terminal on the power supply. The purpose is proper grounding for the level probes to operate correctly on Ultra Autofill models.
9. Install power supply with screws back through the machine mounting key holes and tighten.

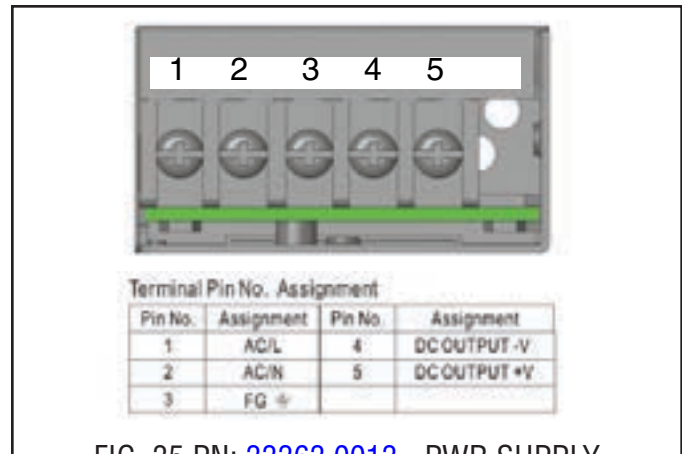


FIG. 35 PN: [33363.0013](#) - PWR SUPPLY

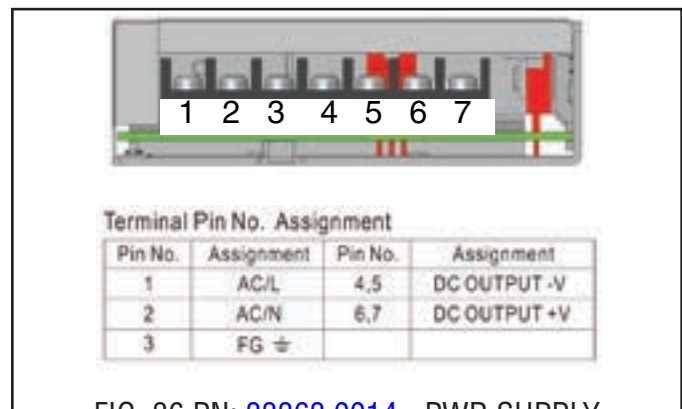


FIG. 36 PN: [33363.0014](#) - PWR SUPPLY

SERVICE - RIGHT SIDE PANEL COMPONENTS

Tri-Output Power Supply

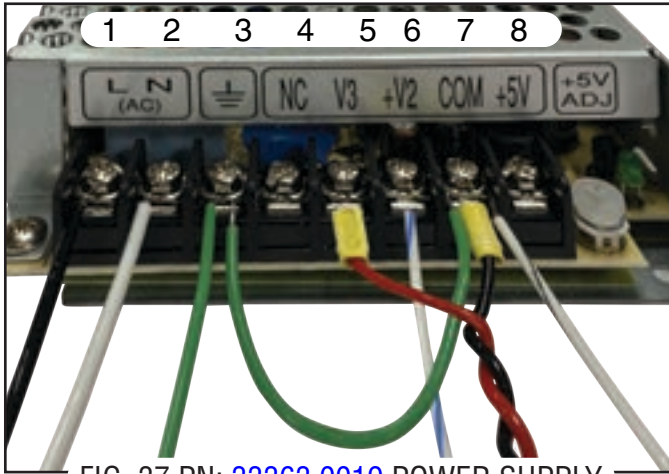


FIG. 37 PN: 33363.0019 POWER SUPPLY

Location:

The Tri-Output power supply may be found in customer specific dispensers. The Tri-Output power supply is located behind right side panel and mounted to the side frame above the capacitors.

Right Panel Removal:

1. Loosen 2 right side panel screws on the underside of the machine.
2. Grab and lower the right panel while pulling the bottom outward to remove panel.

Test Procedures:

NOTE: The power supply accepts incoming 88-264VAC and steps down and converts the voltage to three outputs, 5VDC, 24VDC and 12VDC. The power supply has an LED power indicator.

1. Check power supply L & N terminals for incoming AC power.
No AC power or power LED illumination, check power source for power before replacing power supply.
Yes AC power on L & N power supply terminals.

2. Check the three VDC Output (V1, V2 & V3) terminals to DC common output terminal 7 on the power supply.

V1 = 5VDC - Terminal 8 -Not Used

V2 = 24VDC - Terminal 6

V3 = 12VDC - Terminal 5

Terminal 7 - DC Common Output (Negative)

No DC power, replace power supply.

Part Removal and Replacement:

1. Disconnect power supply to the machine.
2. With right side panel removed, locate the power supply.
3. Loosen 2 key lock screws securing power supply to the machine frame.
4. Pull power supply with screws out of the machine key holes. Finish removing the screws from power supply and retain screws.
5. Note the position of wire/colors on the power supply terminals.
6. Disconnect wires from the power terminals. discard power supply.
7. Install screws retained in step 4 into the replacement power supply.
8. Reconnect wires to the Tri-Output Power supply terminals.

Terminals 1 thru 8:

1 - **L** = Line AC – Black wire

2 - **N** = Neutral AC – Solid white wire

3 - **Ground** = Green wire to chassis ground

4 - **NC** = No Connection

5 - **V3** = 12VDC - Red wire power to IOT

6 - **+V2** = 24VDC to Ultra NX – White with blue stripe

7 - **COM** = Common/ground – White with black stripe to Ultra NX, Green jumper to ground, Black negative to IOT.

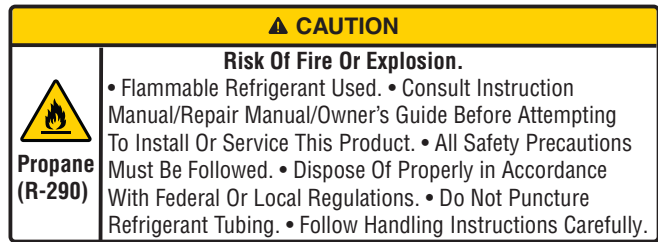
8 - **+5V** = Not used

NOTE: Ensure green jumper wire is installed into terminal 3 & 7 on the power supply. The purpose is proper grounding for the level probes to operate correctly on Ultra Autofill models.

9. Install power supply with screws back through the machine mounting key holes and tighten.

SERVICE - HAZARD CLASSIFICATION & SAFEGUARDS

R-290 Compressor Hazard Classification and Safeguards



Important Safeguards:

- Trained service personnel with the knowledge of servicing and troubleshooting R-290 refrigeration systems or related components should be used.
- All components used in Ultra NX are rated for refrigerant R-290 application.
- Always be alert of smell and sounds (arching, popping and humming) coming from the compressor. Disconnect power or unplug immediately and get away.
- Always ensure main power is disconnected before any removal of a protective cover.
- Compressor oil and refrigerant being vented can create a hazardous risk of fire or explosion, chemical burn or asphyxiant.
- Never reset a breaker or replace a blown fuse without checking the compressor or related components for a short circuit or ground fault condition first.
- Always wear and use the appropriate safety gear when servicing a refrigeration system. Protective gloves, eye wear, shoes, clothes and tools.
- If compressor ground fault condition exists, keep power off, disconnect power leads, mark or tag compressor to indicate ground fault or defective compressor before replacing with a new compressor.

SERVICE - RIGHT SIDE PANEL COMPONENTS

R-290 Compressor

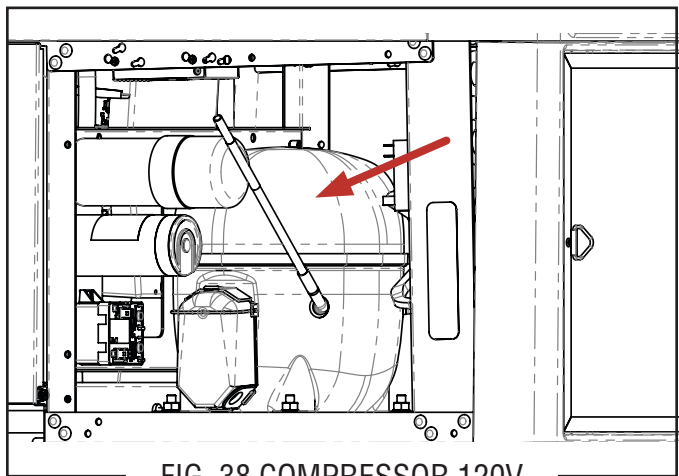


FIG. 38 COMPRESSOR 120V

Location:

The compressor is located front center behind the front panel.

WARNING: Before repair and/or removal of any refrigeration component must be performed by a trained and licensed R-290 repair technician.

Right Panel Removal:

1. Loosen 2 right side panel screws on the underside of the machine.
2. Grab and lower the right panel while pulling the bottom outward to remove panel.
3. If needed, repeat steps for left side panel.

Test Procedures:

NOTE: A megger is a preferred test over using a typical ohm meter for testing the compressor windings. The megger checks the insulation factor of a winding making sure it is actually insulated and not leaking current (Ground Fault). An ohm meter usually produce a low voltage for reading resistance verses a megger uses higher direct voltage source to measure insulation resistance to detect a breakdown in the motor winding insulation.

1. Disconnect main power to the dispenser.
2. Unclip and remove protective cover from compressor terminals.
3. Access compressor terminal pins and disconnect the wire leads going to the compressor pins. See FIG. 39.
4. Set the megger to the compressor applicable voltage rating. If the megger you are using only has a few specific voltage ranges, select the next highest voltage above your compressor volt range.

5. Connect one lead of the megger to the copper suction line or housing. Connect the other lead to one of the compressor terminal pins (winding).
6. Repeat the procedure for the two remaining terminal pins. If the instrument indicates any resistance less than 2 megohms between any pin and the housing (copper suction line),

120V Compressor Specifications:

Model Number: NE X4170UA

Motor Type: CSCR

Commercial Designation: 1/2 HP

Nominal Voltage & Frequency:
115-127 vac 60 hz, 1 Phase

Evaporating Temperature Range:
-40°F [-40°C] to 32°F [0°C]

Electrical Rating: 9 FLA, 49.50 LRA

Main (run) Winding Resistance:
.96 Ohms @ 77°F [25°C] ±8%

Start Winding Resistance:
3.81 Ohms @ 77°F [25°C] ±8%

Displacement (max): 1.025 in³ [16.80 cm³]

Refrigerant: R-290

Oil Type/Viscosity: Ester/ ISO22

Oil Charge: 11.84 fl. oz. [350 ml.] ±5%

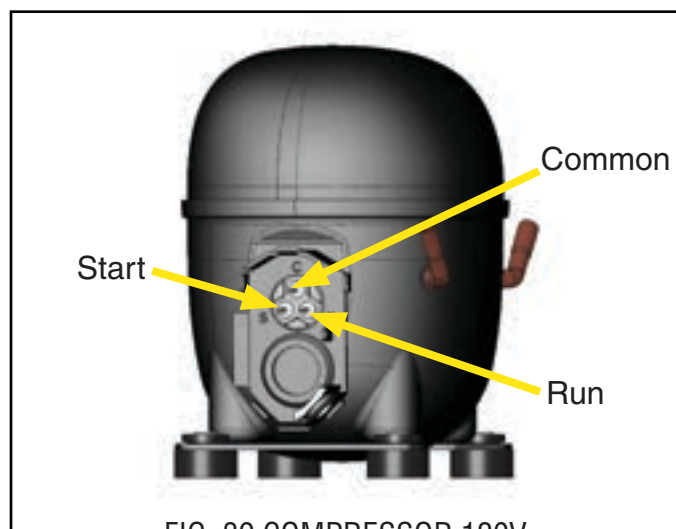


FIG. 39 COMPRESSOR 120V

SERVICE - RIGHT SIDE PANEL COMPONENTS

R-290 Compressor

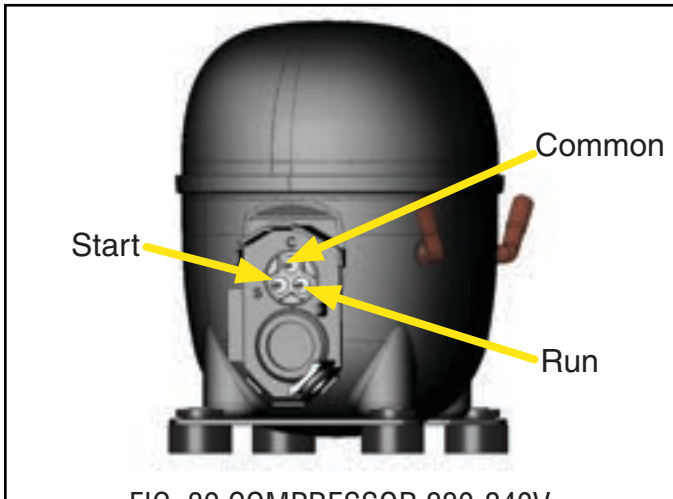


FIG. 39 COMPRESSOR 220-240V

220-240V Compressor Specifications:

Model Number: NEU2178U

Motor Type: CSCR

Commercial Designation: 1 HP

Nominal Voltage & Frequency:

220-240 VAC 50 Hz 1 Phase

Evaporating Temperature Range:

-40°F [-40°C] to 14°F [-10°C]

Electrical Rating: 3.82 FLA, 21.00 LRA

Main (run) Winding Resistance:

4.97 Ohms @ 77°F [25°C] ±8%

Start Winding resistance:

10.43 Ohms @ 77°F [25°C] ±8%

Displacement (max): 1.141 in³ [18.70 cm³]

Refrigerant: R-290

Oil Type/Viscosity: Ester/ ISO22

Oil Charge: 11.84 fl. oz. [350 ml.] ±5%

WARNING: Part Removal & Replacement:

This will require a trained and licensed R-290 technician to make the necessary repair of the R-290 refrigeration system.

NOTE: When replacing the compressor it is recommended that the dryer also be replaced.

1. Disconnect main power supply to the machine.
2. The Licensed R-290 Certified Technician will perform the refrigerant R-290 recovery procedure.
3. The Licensed R-290 Technician will disconnect the compressor from the refrigerant system.
4. The Licensed R-290 Technician will unclip and remove protective cover from compressor terminals and disconnect wires from the compressor pin terminals.

5. Next, technician will remove the four .25-20 keps nuts and washers securing the compressor to the chassis. Set nuts and washers aside for reassembly.
6. From the left side of the dispenser, lift the compressor assembly over the four studs in the chassis and remove compressor.
7. The Licensed R-290 Technician will install replacement compressor over the four studs in the dispenser chassis with the compressor pin terminals facing the right side of the dispenser.
8. Secure compressor to the dispenser chassis using four .25-20 keps nuts and washers.
9. The Licensed R-290 Technician will reconnect compressor and new filter dryer to the refrigeration system.
10. The Licensed R-290 Technician will reconnect the wires onto the compressor pin terminals.
11. The Licensed R-290 Technician will perform the standard procedures of evacuating and recharging the refrigeration system.
12. Finally, the Licensed R-290 Technician will perform system checks after repair.

R290 Charge Specification for 120V Models:

CHARGE

Type R290, Amount **4.16** oz (118 gm)

Design Pressures: GWP=3

High **430** psi (29.6 bar) (2.96 MPa)

Low **80** psi (5.5 bar) (0.55 MPa)

R290 Charge Specification for 220V Models:

CHARGE



**Propane
(R-290)**

Type R290, Amount **4.0** oz (114 gm)

Design Pressures: GWP=3

High **430** psi (**29.6** bar) (**2.96** MPa)

Low **80** psi (**5.5** bar) (**0.55** MPa)

WARNING: The charging of the system must be done by a trained licensed R-290 refrigeration repair technician.

CAUTION: Refer to Compressor Wiring Diagram when reconnecting wires to Compressor, Start Relay, and Start & Run Capacitor.

SERVICE - RIGHT SIDE PANEL COMPONENTS

Compressor Start Capacitor

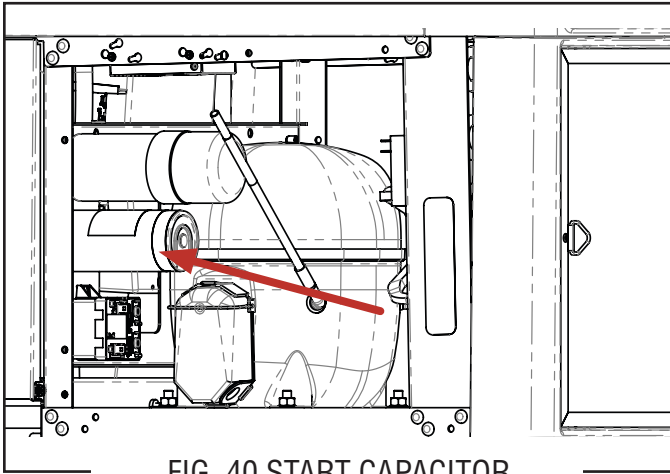


FIG. 40 START CAPACITOR

Location:

The Start and Run Capacitor are located right side, up front between the start relay and power supply.

Right Panel Removal:

1. Loosen 2 right side panel screws on the underside of the machine.
2. Grab and lower the right panel while pulling the bottom outward to remove panel.
3. Front panel will need to be removed to access the nuts securing capacitors to the machine frame.

See "Service Front Panel Components" on how to remove Front Panel.

Test Procedures:

CAUTION: Start Capacitors having a bleed resistor across the terminals will bleed off residual voltage in a start capacitor after it has been removed from a motor circuit after start up. Not all Start or Run capacitors use bleed resistors.

The bleed resistor is used as a safety feature to discharge or eliminate the possibility of a leftover charge that could cause an electric shock if not handled properly during servicing of the equipment.

IMPORTANT: Examine the Start capacitor for a bleed resistor before testing the start capacitor with a capacitance meter.

If the capacitor you are replacing had a bleed down resistor, then make sure your replacement start capacitor has one or you will need to test the old resistor to make sure it is good before reinstalling it across the replacement start capacitor not having one.

Typically a bleed resistor resistance value should read somewhere between 10 to 20k Ohms.

Start Capacitor

1. Disconnect main power from the machine.
2. Use Multimeter with Capacitance Setting.
3. **WARNING:** Ensure the start capacitor is discharged before disconnecting the start capacitor wires from the machine and remove start capacitor.
4. If a bleed resistor is parallel across the start capacitor terminals, isolate bleed resistor from capacitor terminals. See FIG. 41.
5. Look and take note of the micro Farads rating on the side of the capacitor.
6. Set multimeter to read capacitance/micro Farads.
7. A non polarized capacitor, connect the multimeter leads either way to the capacitor terminals.

NOTE: In case of polarized capacitor, connect the red probe to the positive terminal of the capacitor (generally, the longer lead) and the black probe to the negative terminal (usually, there will be a marking on the side).

8. The multimeter reading should be within the rated value on the side of the start capacitor and/or within the percentage tolerance. Usually the tolerance is not more than +/- 10%.
9. If the multimeter reading is way far from the rated value or out of the allowable percentage range, replace start capacitor.

Start Capacitor Rating:

Ultra NX 120V Models:

RATING: 340-408 MFD 165 V 50/60HZ

Ultra NX 200-240V Models:

RATING: 108-130 MFD 330 VAC 50 HZ

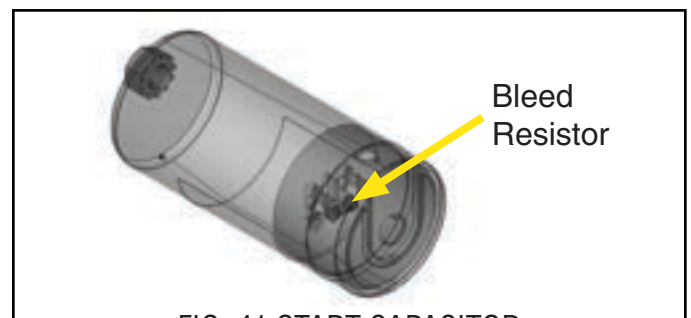


FIG. 41 START CAPACITOR

SERVICE - RIGHT SIDE PANEL COMPONENTS

Compressor Run Capacitor

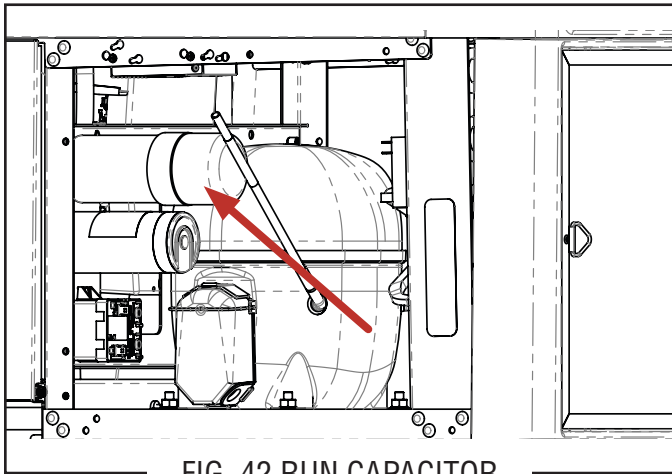


FIG. 42 RUN CAPACITOR

Location:

The Start and Run Capacitor are located right side, up front between the start relay and power supply.

Right Panel Removal:

1. Loosen 2 right side panel screws on the underside of the machine.
2. Grab and lower the right panel while pulling the bottom outward to remove panel.
3. Front panel will need to be removed to access the nuts securing capacitors to the machine frame.

See "Service Front Panel Components" on how to remove Front Panel.

Test Procedures:

Caution: The Run Capacitor is not required to have a bleed resistor.

A safe way to discharge a Run Capacitor, take a 20,000 Ohm resistor and connect each end to a jumper wire with a pair of alligator clips and take the other end of the alligator clips and connect across the terminals of the run capacitor. The capacitor will slowly discharge while monitoring the voltage across the run capacitor terminals with a multimeter.

Run Capacitor

1. Disconnect main power from the machine.
2. Use Multimeter with Capacitance Setting.
3. Warning: Ensure the start capacitor is discharged before disconnecting the run capacitor wires from the machine and remove run capacitor.

4. Look and take note of the micro Farads rating on the side of the capacitor.
5. Set multimeter to read capacitance/micro Farads.
6. A non polarized capacitor, connect the multimeter leads either way to the capacitor terminals.
NOTE: In case of polarized capacitor, connect the red probe to the positive terminal of the capacitor (generally, the longer lead) and the black probe to the negative terminal (usually, there will be a marking on the side).
7. The multimeter reading should be within the rated value on the side of the run capacitor and/or within the percentage tolerance. Usually the tolerance is not more than +/- 10%.
9. If the multimeter reading is way far from the rated value or out of the allowable percentage range, replace run capacitor.

Run Capacitor Rating:

Ultra NX 120V Models:

RATING: 30 ±5% MFD 420 VAC 50/60HZ

Ultra NX 200-240V Models:

RATING: 12.5 ±5% MFD 420 VAC 50 HZ



FIG. 43 RUN CAPACITOR

SERVICE - RIGHT SIDE PANEL COMPONENTS

Start and Run Capacitor

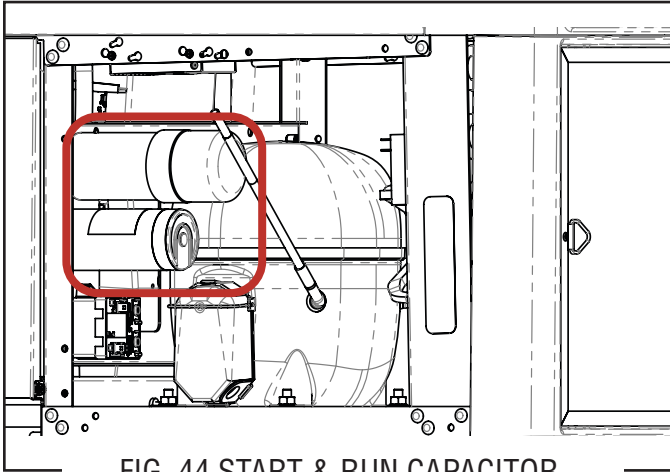


FIG. 44 START & RUN CAPACITOR

WARNING: Part Removal & Replacement:

Follow instruction outlined under Start and Run Capacitor Test Procedure to ensure the capacitor is completely discharged before removal and replacement of capacitor.

1. Disconnect power supply to the machine.
2. With left, right and front panel removed, locate the capacitor being replaced.
3. Note the position of the capacitor wires onto the start relay.
4. Disconnect capacitor wires from the start relay.
5. Use a 1/2" socket or wrench to remove the nut securing the capacitor to the machine frame. Retain nut.
6. install replacement capacitor and secure with retained nut from step 5.
7. Connect capacitor wires to the proper terminal number on the start relay that was noted in step 3.

SERVICE - RIGHT SIDE PANEL COMPONENTS

Start Relay

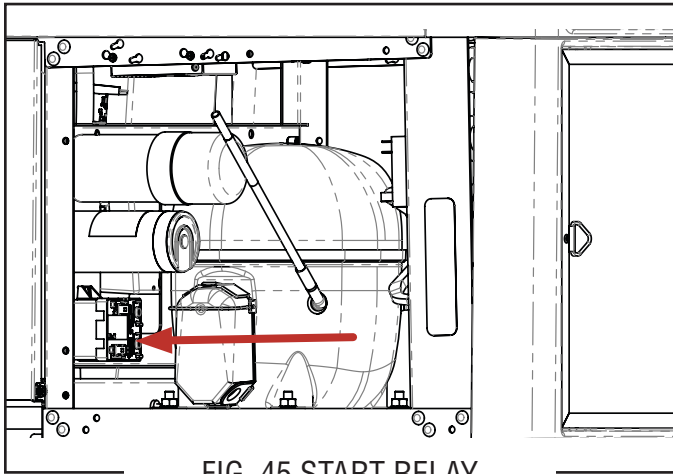


FIG. 45 START RELAY

Location:

The start relay is located right side, up front below the capacitors.

Right Panel Removal:

1. Loosen 2 right side panel screws on the underside of the machine.
2. Grab and lower the right panel while pulling the bottom outward to remove panel.

Test Procedures:

WARNING: Follow instruction outlined under Start and Run Capacitor Test Procedure to ensure each capacitor is completely discharged before removal of wires from the start relay for testing purposes.

1. Disconnect main power supply to the machine.
 2. Follow procedure outlined under each capacitor on how to discharge each capacitor.
 3. Once capacitors are discharged, note the position of wires (color & size) going to the start relay terminals.
 4. Disconnect wires from the start relay terminals.
 5. Use an multimeter to troubleshoot a start relay.
 6. Set multimeter on continuity (resistance) setting.
 7. Make sure start relay is in correct mounting position.
 8. Place meter leads onto start relay terminal 1 and 2. The resistance should read 0.00 (continuity). See FIG. 46.
- No continuity reading (infinite) across terminal 1 and 2, replace start relay.
9. Next, check the resistance of the start relay coil across terminals 2 and 5.

10. Place multimeter leads across terminal 2 & 5. If multimeter does not have auto adjustment, adjust the resistance scale (Ohms) on the multimeter to higher resistance range. See FIG. 46.

11. The start relay coil resistance should be represented on the multimeter display. The start relay coil is good.

No resistance (infinite) on high (Ohm) range, replace start relay.

NOTE: An infinite start relay coil will prevent opening of the contact between terminal 1 and 2 on the start relay.

Start Relay Rating:

Ultra NX 120V Models:

RELAY, NEX4170UA 115-127V 60 HZ

Ultra NX 200-240V Models:

RELAY, NEU2178U 220-240V 50 HZ

WARNING: Part Removal and Replacement:

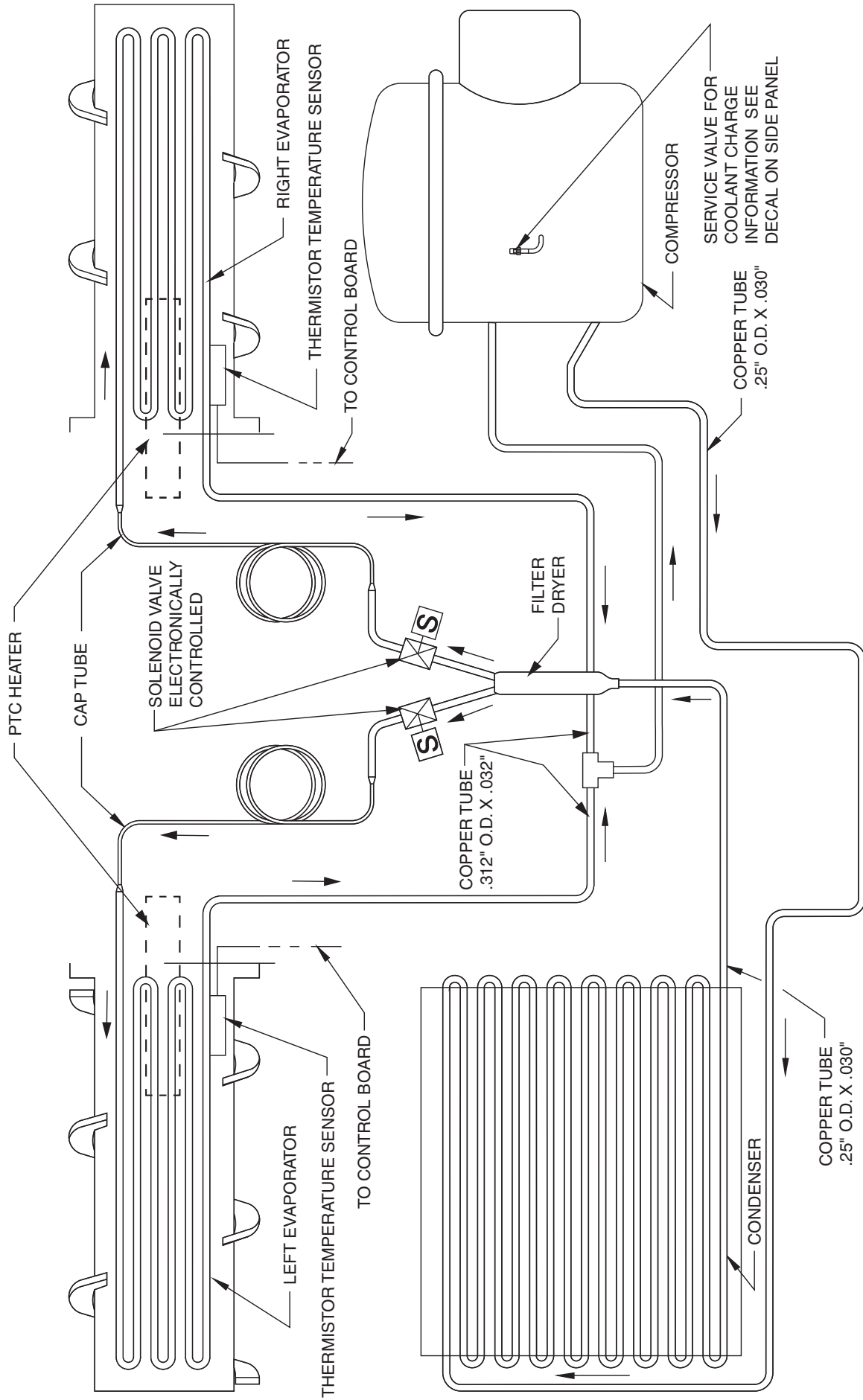
Follow instruction outlined under Start and Run Capacitor Test Procedure to ensure each capacitor is completely discharged before removal and replacement of start relay.

1. Disconnect main power supply to the machine.
2. Follow procedure outlined under each capacitor on how to discharge each capacitor.
3. Once capacitors are discharged, note the position of wires (color & size) going to the start relay terminals.
4. Disconnect wires from the start relay terminals.
5. Remove 1 screw securing the start relay to the machine frame.
6. Install replacement start relay and secure with screw.
7. Reconnect wires to the start relay terminals as noted in step 3.

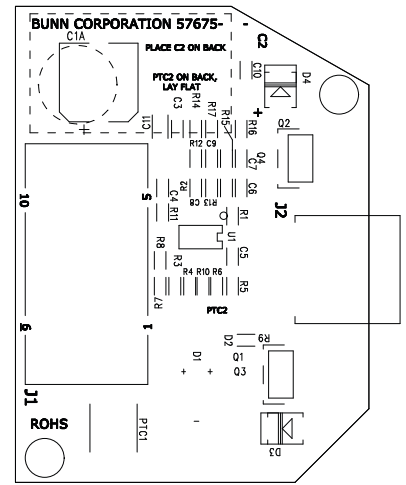
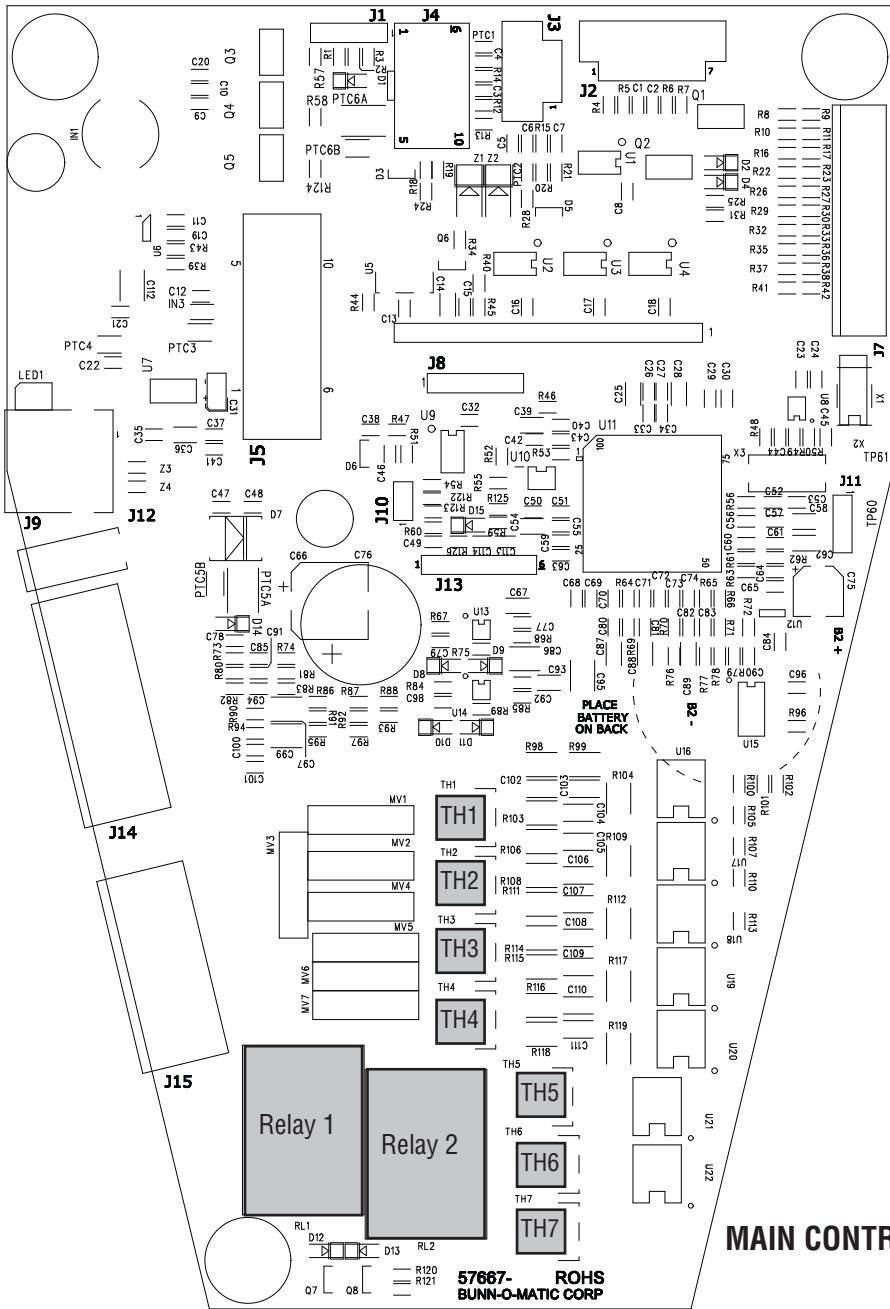


FIG. 46 START RELAY

R-290 COOLANT DIAGRAM



CONTROL BOARD TRIAC DIAGRAM



LIQUID AUTO-FILL BOARD

TRIAC	DESCRIPTION	CONNECTOR TERMINAL
TH1	Right Refrigerant Solenoid	J15-12
TH2	Left Refrigerant Solenoid	J15-11
TH3	Fan	J15-10
TH4	Left Auger Motor	J15-2 Reverse & J15-3 Forward - Relay 1
TH5	Right Auger Motor	J15-7 Reverse & J15-1 Forward - Relay 2
TH6	Right PTC Heater	J15-9
TH7	Left PTC Heater	J15-8

CONTROL BOARD INPUT AND OUTPUT CHART

J12-2pin Connector -Power Supply Input 24VDC

J14-14pin Connector Main Harness - Low Voltage

J15-12pin Connector for Main Harness - Line Voltage

CONNECTOR & PIN NUMBER	WIRE COLOR	INPUT/OUTPUT	DESCRIPTION	VOLTAGE
J12-1	WHT/RED	Input/+	Control Board	24VDC
J12-2	WHT/BLK	Input/-	Control Board	24VDC
J14-1	WHI/BLK	Input	Ground	5.0VDC
J14-2	WHI/BLU	Output/+	24VDC Rated Parts	24VDC
J14-3	BRN	Input/Signal	Left Thermistor	*1.0 - 5.0VDC
J14-4	WHI/YEL	Input/Signal	Right Thermistor	*1.0 - 5.0VDC
J14-5	YEL	Input/Signal	Hot Gas Thermistor	*1.0 - 5.0VDC
J14-6	BLU	Output/+	Torque Sensor	5.0VDC
J14-7	WHT/BLK	Input	Ground	5.0VDC
J14-8	WHT/GRAY	Input/Signal	Left Torque	0 - 5VDC
J14-9	WHT/GRN	Input/Signal	Right Torque	0 - 5VDC
J14-10	TAN	Input	Left Level Sensor	5.0VDC
J14-11	PINK	Input	Right Level Sensor	5.0VDC
J14-12	VIOLET	Output/-	Left Hopper Lights	24VDC
J14-13	WHI/VIOLET	Output/-	Right Hopper Lights	24VDC
J14-14	ORG	Output/-	Compressor Relay	24VDC
J15-1	RED/BLK	Output	Right Forward Auger	120 or 230VAC
J15-2	BRN/WHT	Output	Left Reverse Auger	120 or 230VAC
J15-3	BRN/BLK	Output	Left Forward Auger	120 or 230VAC
J15-4	BLK	Supply/L1	L1	120 or 230VAC
J15-5	WHI	Neutral/L2	Neutral	120 or 230VAC
J15-6	Not Used	Not Used	Not Used	Not Used
J15-7	WHI/RED	Output	Right Reverse Auger	120 or 230VAC
J15-8	WHI/YEL	Output	Left PTC Heater	24VDC
J15-9	WHI/RED	Output	Right PTC Heater	24VDC
J15-10	GRAY	Output	Fan	120 or 230VAC
J15-11	BRN	Output	Left Refrig. Valve	120 or 230VAC
J15-12	RED	Output	Right Refrig. Valve	120 or 230VAC

* Temperature sensor disconnected you will read 5VDC, but when connected, voltage will vary according to real time temperature. Reference Service -Temperature Sensor section.

INPUT AND OUTPUT CHART

J7-12pin Connector - Membrane Switch

J3-4pin BUNNlink

CONNECTOR & PIN NUMBER	WIRE COLOR	INPUT/OUTPUT	DESCRIPTION	VOLTAGE
J7-1	BLK	Input	Ground	
J7-2	ORN	Input	Left Auger	5VDC
J7-3	YEL	Input	I/O	5VDC
J7-4	GRN	Input	Not Used	5VDC
J7-5	BLU	Input	Left Ice/Chill/Off	5VDC
J7-6	VIO	Input	Left Dot	5VDC
J7-7	GRY	Input	Ground	
J7-8	WHI	Input	Center Dot	5VDC
J7-9	TAN	Input	Not Used	
J7-10	PNK	Input	Right Dot	5VDC
J7-11	WHT/BLK	Input	Right Auger	5VDC
J7-12	WHT/RED	Input	Right/Ice/Chill/Off	5VDC
J3-1		Output	5.0V	5.0VDC
J3-2		Output	Communications -TX	
J3-3		Input	Communications - RX	
J3-4		Input	Ground	

WIRING SCHEMATIC

Ultra® NX

