



# SERVICE & REPAIR MANUAL

**Bunn-O-Matic Corporation**  
Post Office Box 3227, Springfield, Illinois 62708-3227  
Phone (217) 529-6601 | Fax (217) 529-6644

## BUNN-O-MATIC COMMERCIAL PRODUCT WARRANTY

Bunn-O-Matic Corp. ("BUNN") warrants equipment manufactured by it as follows:

- 1) Airpots, thermal carafes, decanters, GPR servers, iced tea/coffee dispensers, MCR/MCP/MCA single cup brewers, thermal servers and ThermoFresh® servers (mechanical and digital) 1 year parts and 1 year labor.
- 2) All other equipment - 2 years parts and 1 year labor plus added warranties as specified below:
  - a) Electronic circuit and/or control boards - parts and labor for 3 years.
  - b) Compressors on refrigeration equipment - 5 years parts and 1 year labor.
  - c) Grinding burrs on coffee grinding equipment for 4 years or 40,000 pounds of coffee, whichever comes first.

These warranty periods run from the date of installation BUNN warrants that the equipment manufactured by it will be commercially free of defects in material and workmanship existing at the time of manufacture and appearing within the applicable warranty period. This warranty does not apply to any equipment, component or part that was not manufactured by BUNN or that, in BUNN's judgment, has been affected by misuse, neglect, alteration, improper installation or operation, improper maintenance or repair, non periodic cleaning and descaling, equipment failures related to poor water quality, damage or casualty. In addition, the warranty does not apply to replacement of items subject to normal use including but not limited to user replaceable parts such as seals and gaskets. This warranty is conditioned on the Buyer 1) giving BUNN prompt notice of any claim to be made under this warranty by telephone at (217) 529-6601 or by writing to Post Office Box 3227, Springfield, Illinois 62708-3227; 2) if requested by BUNN, shipping the defective equipment prepaid to an authorized BUNN service location; and 3) receiving prior authorization from BUNN that the defective equipment is under warranty.

**THE FOREGOING WARRANTY IS EXCLUSIVE AND IS IN LIEU OF ANY OTHER WARRANTY, WRITTEN OR ORAL, EXPRESS OR IMPLIED, INCLUDING, BUT NOT LIMITED TO, ANY IMPLIED WARRANTY OF EITHER MERCHANTABILITY OR FITNESS FOR A PARTICULAR PURPOSE.** The agents, dealers or employees of BUNN are not authorized to make modifications to this warranty or to make additional warranties that are binding on BUNN. Accordingly, statements by such individuals, whether oral or written, do not constitute warranties and should not be relied upon.

If BUNN determines in its sole discretion that the equipment does not conform to the warranty, BUNN, at its exclusive option while the equipment is under warranty, shall either 1) provide at no charge replacement parts and/or labor (during the applicable parts and labor warranty periods specified above) to repair the defective components, provided that this repair is done by a BUNN Authorized Service Representative; or 2) shall replace the equipment or refund the purchase price for the equipment.

**THE BUYER'S REMEDY AGAINST BUNN FOR THE BREACH OF ANY OBLIGATION ARISING OUT OF THE SALE OF THIS EQUIPMENT, WHETHER DERIVED FROM WARRANTY OR OTHERWISE, SHALL BE LIMITED, AT BUNN'S SOLE OPTION AS SPECIFIED HEREIN, TO REPAIR, REPLACEMENT OR REFUND.**

In no event shall BUNN be liable for any other damage or loss, including, but not limited to, lost profits, lost sales, loss of use of equipment, claims of Buyer's customers, cost of capital, cost of down time, cost of substitute equipment, facilities or services, or any other special, incidental or consequential damages.

392, A Partner You Can Count On, Air Infusion, AutoPOD, AXIOM, BrewLOGIC, BrewMETER, Brew Better Not Bitter, BrewWISE, BrewWIZARD, BUNN Espresso, BUNN Family Gourmet, BUNN Gourmet, BUNN Pour-O-Matic, BUNN, BUNN with the stylized red line, BUNNlink, Bunn-OMatic, Bunn-O-Matic, BUNNserve, BUNNSERVE with the stylized wrench design, Cool Froth, DBC, Dr. Brew stylized Dr. design, Dual, Easy Pour, EasyClear, EasyGard, FlavorGard, Gourmet Ice, Gourmet Juice, High Intensity, iMIX, Infusion Series, Intellisteam, My Café, Phase Brew, PowerLogic, Quality Beverage Equipment Worldwide, Respect Earth, Respect Earth with the stylized leaf and coffee cherry design, Safety-Fresh, savemycoffee.com, Scale-Pro, Silver Series, Single, Smart Funnel, Smart Hopper, SmartWAVE, Soft Heat, SplashGard, The Mark of Quality in Beverage Equipment Worldwide, ThermoFresh, Titan, trifacta, TRIFECTA (stylized logo), Velocity Brew, Air Brew, Beverage Bar Creator, Beverage Profit Calculator, Brew better, not bitter., Build-A-Drink, BUNNSource, Coffee At Its Best, Cyclonic Heating System, Daypart, Digital Brewer Control, Element, Milk Texturing Fusion, Nothing Brews Like a BUNN, Picture Prompted Cleaning, Pouring Profits, Signature Series, Sure Tamp, Tea At Its Best, The Horizontal Red Line, Ultra are either trademarks or registered trademarks of Bunn-O-Matic Corporation. The commercial trifacta® brewer housing configuration is a trademark of Bunn-O-Matic Corporation.

# CONTENTS

WARRANTY .....	2
USER NOTICES .....	4
SITE PREPARATION .....	4
INTRODUCTION .....	4
TEMP & TORQUE SCREEN .....	5
OPERATING CONTROLS .....	6
USING THE DISPENSER FOR GRANITA-TYPE PRODUCTS .....	7
USING THE DISPENSER FOR COLD LIQUID PRODUCTS .....	7
RECOMMENDED CLEANING .....	8
ASSEMBLY FOLLOWING CLEANING .....	9
AUTO-FILL CLEANING INSTRUCTIONS .....	10
PREVENTIVE MAINTENANCE SCHEDULE .....	11
REQUIRED REGULAR MAINTENANCE .....	12,13
TROUBLESHOOTING	
No power .....	14
Chills but won't freeze .....	15
No cooling at all .....	16
Freezes, but not thick enough .....	17
No hood lamps .....	17
Noise .....	18
Auger won't turn .....	18
Torque sensor error .....	19
Temperature sensor error .....	20
Clean filter messages .....	21
SERVICE	
Access Panels .....	22
Auger Motors .....	23
Auger Motor Capacitors .....	24
Auger Shaft Assembly .....	25,26
Circuit Breaker .....	27
Compressor	
<i>Americold</i> .....	28,29,30
<i>Embraco</i> .....	31,32,33,34,35,36,37
Relay (or Contactor on Early Models) .....	38
Control Board .....	39
Cooling Drum Alignment .....	40
Fan .....	41
Hot Gas Temperature Sensor .....	42
Lamp Cord Assembly .....	43
Lamp Cord Connector .....	44
Lamp Holder/Socket Assembly .....	45
LED Lamps .....	46
Lamp Relay .....	47
Membrane Switch .....	48
Solenoids .....	49
Temperature Sensor .....	50
Torque Sensor Circuit Board .....	51
Transformer .....	52
Auto Fill Systems .....	53,54,55,56
Coolant Schematics .....	57
Triac Maps .....	58
Input and Output Chart .....	59
Electrical Schematics .....	60,61,62

## USER NOTICES

Carefully read and follow all notices on the equipment and in this manual. They were written for your protection. All notices are to be kept in good condition. Replace any unreadable or damaged labels.

## SITE PREPARATION

The dispenser is very heavy. Place it on a sturdy counter or shelf capable of supporting at least 180 lbs. It is for indoor use only.

The dispenser must have at least six inches of space behind it. This space is needed for airflow, air filter removal, and cleaning. A clearance of at approximately six inches is recommended between the dispenser sides and the wall or another appliance. The dispenser performs better if not placed near any heating appliance. Leave some space so the dispenser can be moved for cleaning.

This equipment contains fluorinated greenhouse gases covered by the Kyoto Protocol. Hermetically sealed system. Type R404a, 312 g (11 oz), GWP 3922, CO2 equivalent 1.22t.

This equipment contains fluorinated greenhouse gases covered by the Kyoto Protocol. Hermetically sealed system. Type R452a, 312 g (11 oz), GWP 2140, CO2 equivalent 0.67t.

## INTRODUCTION

### Safety First!

To avoid electrical shock, unplug dispenser from power source before servicing inside.

**WARNING:** When powered, the condenser cooling fan will turn on every 30 minutes to aid cooling the entire unit, even when not in the ICE or CHILL modes. **KEEP HANDS AWAY FROM FAN!**

### Basic Maintenance

In order to maintain proper machine operation, the shaft seals and bushings need to be replaced as a Preventive Maintenance measure. A reminder message will appear every 6 months. Worn/dirty shaft seals/bushings will have a direct effect on torque sensing and prevent complete freezing in “ICE” mode.

### “UPPER” case vs “lower” case

Before beginning the process of troubleshooting, verify simple operating modes, ie; “CHILL” mode will not freeze the product, but “ICE” mode will. You should also observe the letter case size in either mode. UPPER case means the solenoid valve for that side is open, lower case, solenoid is closed.

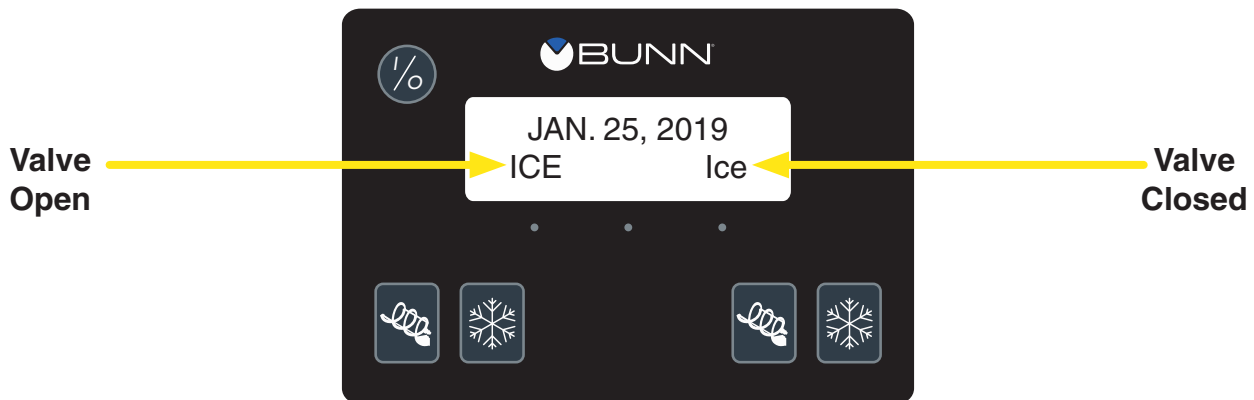

### Fault Codes

To aid in troubleshooting, fault codes are now incorporated into the display. See “Troubleshooting”.

## TEMP & TORQUE SCREEN

Press and hold for five seconds the left and right hidden switches to display the TEMP & TORQUE. The temperature of each cooling drum and the hot gas temperature will toggle back and forth. The auger torque is displayed continuously. Press and release the left and right hidden switches to return to HOME SCREEN. The TEMP & TORQUE mode is typically used for service.

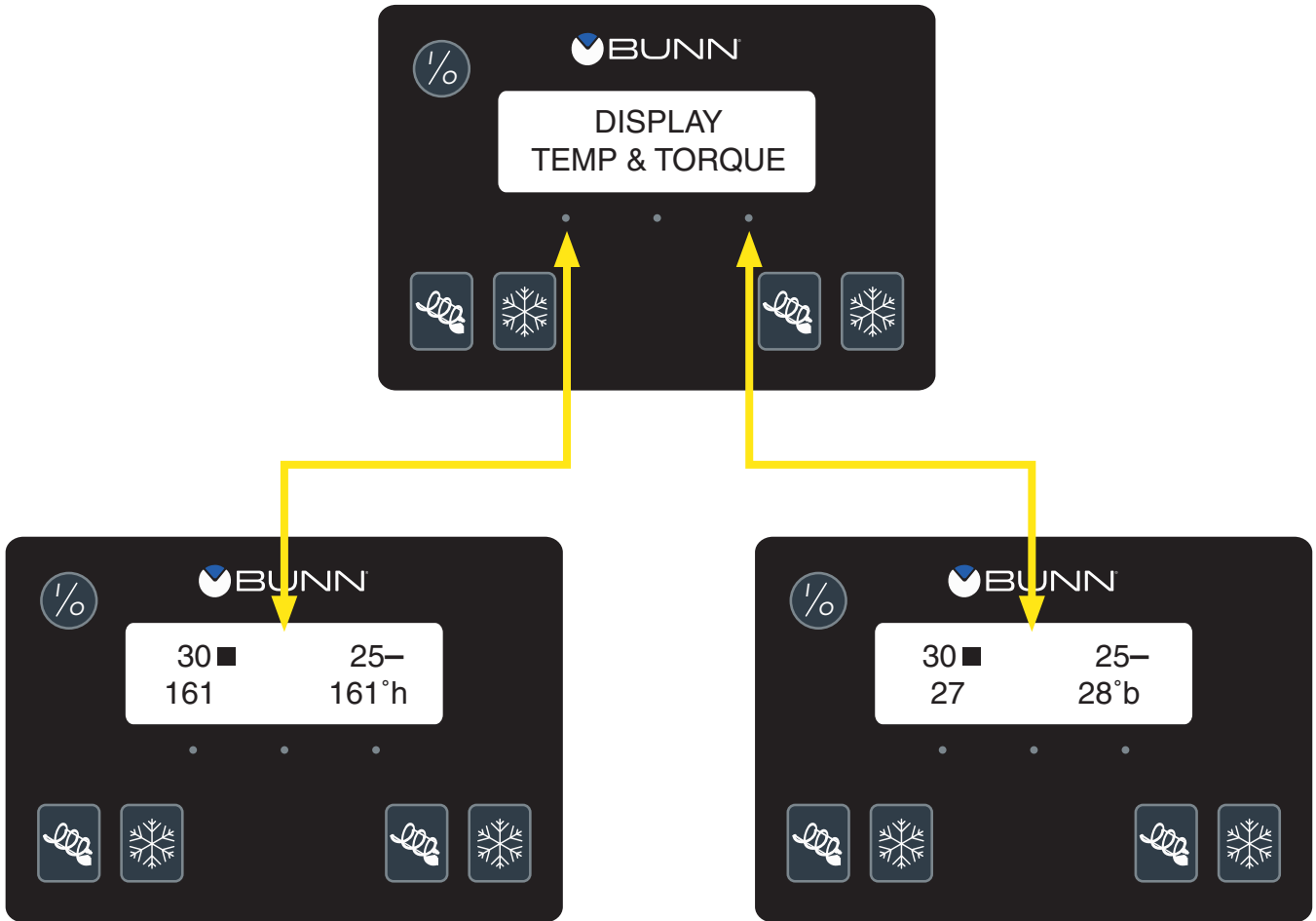

**NOTICE:** While in the TEMP & TORQUE screen, the UPPER/lower case will be replaced by symbols. The ■ indicates the solenoid valve is open, and the — indicates that solenoid is closed.

## OPERATING CONTROLS

There are five of these switches that will be used for the operation of the dispenser.

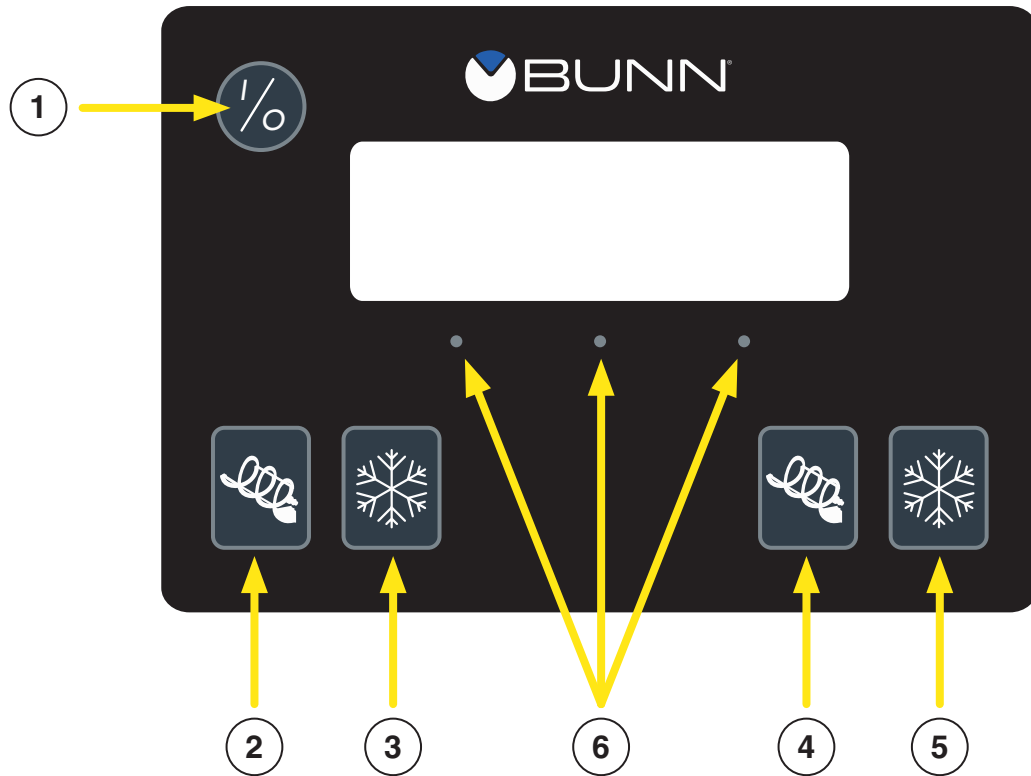

1. Switch (upper left corner of the control pad)

This switch is the ON/OFF toggle switch which powers up the dispenser and the LCD display. When ON the Date and Time toggle back and forth continuously except during programming.



2. (bottom left corner)

This is used to turn the left side auger motor to AUGER ON, AUGER OFF or AUGER REFILL ON. (Refill only applicable when installed)



3. (bottom left corner)

This is used to turn the left side ice control to OFF, ICE or CHILL.



4. (bottom right corner)

This is used to turn the right side auger motor AUGER ON, AUGER OFF or AUGER REFILL ON. (Refill only applicable when installed)



5. (bottom right corner)

This is used to turn the right side ice control to OFF, ICE or CHILL.

- • • 6. Hidden buttons used for Programming.

## USING THE DISPENSER FOR GRANITA-TYPE PRODUCTS

1. Lift the lid slightly for the selected hopper and slide back to gain access to the hopper.
2. Place the pre-mixed liquid product in the selected hopper.



3. Press and release the ON/OFF switch to power on the dispenser.



4. Press and release the appropriate (left or right side) ON/OFF switch to start the Auger Motor and to turn on AutoFill when applicable. (See \*NOTE)



5. Press and release the (OFF/ICE/CHILL) switch and select ICE to begin the cooling process for the selected hopper.

6. Wait for the liquid to freeze to the desired consistency.

**HINT:** BUNN recommends that the product in the dispenser be thawed each day, usually overnight. The ice granules get too large and a consistent product is difficult to maintain if left frozen for an extended period of time. Set the NIGHT mode for a few hours each night and return it to the DAY mode when the product has thawed sufficiently. You'll know it is in the NIGHT mode because the display will indicate NIGHT MODE, and the hopper light(s) will turn off.

## USING THE DISPENSER FOR COLD LIQUID PRODUCTS

1. Lift the lid slightly for the selected hopper and slide back to gain access to the hopper.
2. Place the pre-mixed liquid product in the selected hopper.



3. Press and release the ON/OFF switch to power on the dispenser.



4. Press and release the appropriate (left or right side) ON/OFF switch to start the Auger Motor and to turn on AutoFill when applicable. (See \*NOTE)



5. Press and release the (left or right side) OFF/ICE/CHILL switch and select CHILL to begin the cooling process for the selected hopper.

6. Wait for the liquid to cool.

**\*NOTE:** Refill system includes a “Maximum Fill Time” in the software. If the time to fill the hopper exceeds this limit, the hopper lights will flash and a “Refill Fault” will be displayed on the screen. If this occurs, check the product supply to ensure the BIB is not empty. (Change BIB if empty). Then press the “ULTRA” button for 3 seconds to clear the fault and restart the refill system.

## RECOMMENDED CLEANING

Frequency of cleaning should be as directed by the product manufacturer.

1. Turn cooling to OFF selection. Empty all product from the hopper(s). Turn auger to OFF selection. Disconnect the hopper lid lamp cord(s) and remove the lids. On models with autofill, disconnect fill hoses and level probe from hopper.

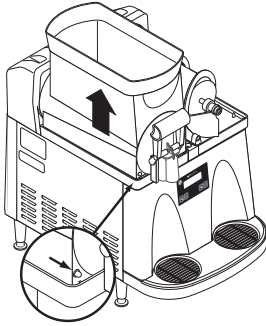

2. Depress the hopper lock plunger. Lift the hopper up slightly.

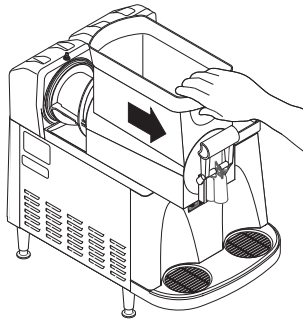

3. Pull forward to remove.

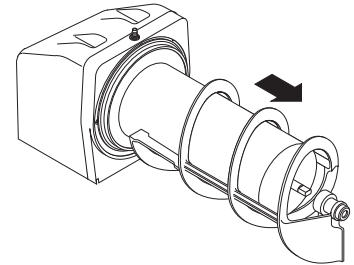

4. Pull the auger from the cooling drum.

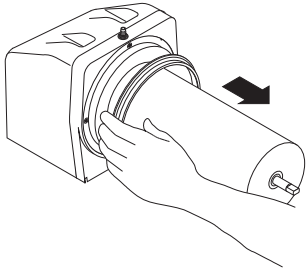

5. Remove the cooling drum seal from the rear of the drum.

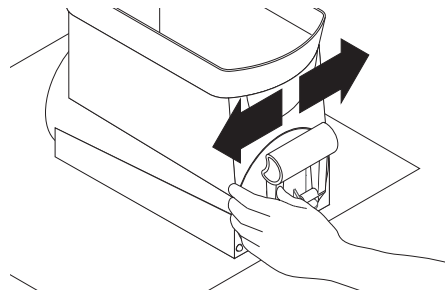

6. **CAUTION:** The faucet valve is under spring tension. Spread one side of the handle first, then the other and disconnect from the hopper.

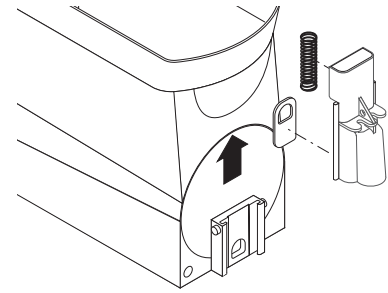

7. Carefully slide the faucet valve up to remove the spring and faucet seal. Extra care should be taken when handling the seal to prevent damage. Do not fold the seal as this will cause damage to the Teflon® sealing surface.

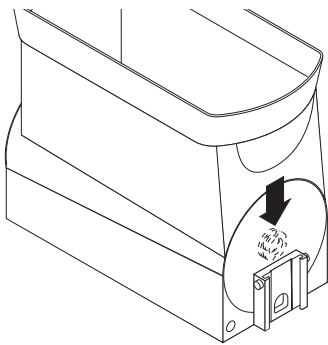

8. Remove the auger nose bushing from inside the hopper.

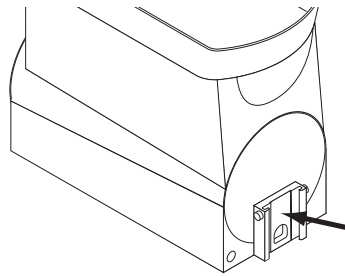

9. Care must be taken to ensure this surface does not get scratched during cleaning. Deep scratches could cause leakage around the seal.

10. Place all parts in a clean sink with mild hot water (120°F) and sanitizer solution. Allow all parts to soak for at least 5 minutes. Carefully wash all components with a clean wash cloth in the hot water and sanitizer solution. Use a clean, soft bristle brush as needed for the smaller components and tight areas. Do not immerse hopper lids. Use a commercial sanitizer that has 100 ppm of available chlorine with a concentration level of at least 3% available chlorine (KAY-5 Sanitizer). Follow the sanitizer's mixing instructions to ensure 100 ppm of available chlorine.

11. Wash the drums, hopper drip trays, top covers, and outer enclosure using a clean wash cloth that has been dampened in the hot water and sanitizer solution. Pay particular attention to the shaft area and make sure it is thoroughly cleaned and sanitized.

12. Thoroughly rinse all surfaces with a clean wash cloth that has been dampened with hot water. Wipe dry with a clean dry wash cloth before reassembling the dispenser.

**NOTE:** Although most parts are dishwasher safe, they may be affected by the chemicals in some commercial sanitizing agents. Do not place the hopper nor hopper lids in a dishwasher. Rinse thoroughly before assembly.

## ASSEMBLY FOLLOWING CLEANING

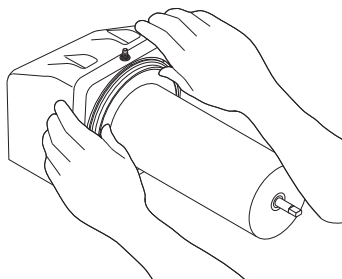

1. Install the seal(s) over the flange at the rear of the cooling drum(s) and press the seal(s) firmly into place as shown. Apply a small amount of lubricant on seal.

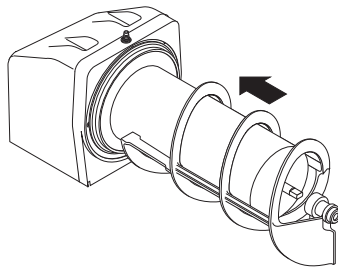

2. Align the auger shaft(s) with the auger(s). Push the auger(s) as far as they will go and rotate so the flat face of the auger shaft is aligned with the flat face of the auger nose.

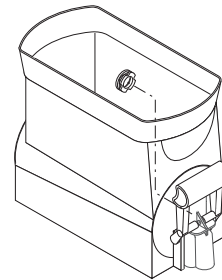

3. Install auger nose bushing into inside front of hopper.

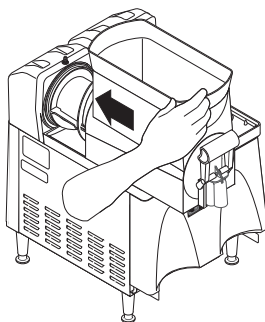

4. Thoroughly rinse the hopper(s) and install over the auger(s) and cooling drum(s).

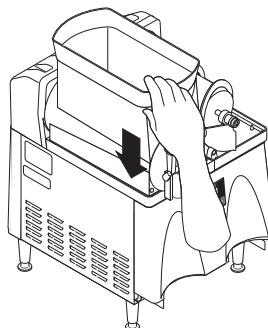

5. Slide into place and push down until the hopper lock plunger(s) snap into place. On models with autofill, reconnect fill hoses and level probe to hopper.

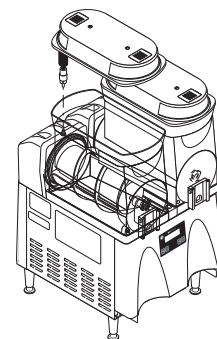

6. Set the lids on the hopper(s) and plug in the hopper lid lamp cord(s).

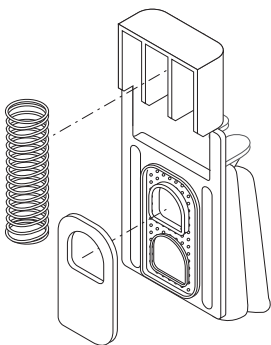

7. Position the faucet seal and return spring in the faucet valve.

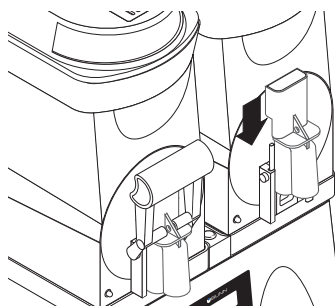

8. Slide the faucet valve assembly into place on the hopper.

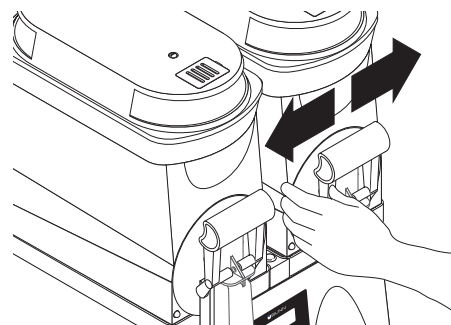

9. Press down on the valve to compress the spring. Position the faucet handle over the faucet valve one side at a time and snap into place on the hopper.

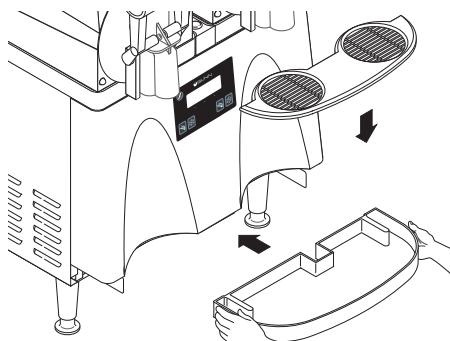

10. Assemble the drip tray.



11. Turn ON augers and cooling function to desired settings.

## **AUTO-FILL CLEANING INSTRUCTIONS** (WITH BRIXING PUMP INSTALLED)

### **Materials required**

1. Non-sudsing liquid detergent (such as common household automatic dishwasher liquid detergent).
2. Household bleach (Sodium chloride solution: 5.25%) or equivalent.
3. Clean five (5) gallon bucket.
4. Measuring Cup
5. An adaptor is needed to hold the Q.C.D. (Quick Connect/Disconnect) fitting on the concentrate suction line open. A connector from an empty bag will work.

### **Sanitizing Procedure**

1. Fill bucket with 4 gallons of warm water (120-180 deg. F).
2. Measure 4 ounces (1/2 cup) of the liquid detergent and add to the water.
3. Measure 2 ounces (1/4 cup) of bleach and add to the water, then stir, mixing evenly.
4. Ensure that the refill for the Ultra hopper is turned off.
5. Empty all product from the Ultra hopper
6. Disconnect the concentrate line from the B-I-B and install adaptor on the quick disconnect so the line is open to the sanitizing solution. Place concentrate inlet line into the bucket so that the Q.C.D. will stay at the bottom.
7. Press the auger button to turn on the "Auger Refill On" feature.
8. Allow system to run until the hopper is about 1/4 full then turn off refill.
9. Switch three way sanitize valve to the Sanitize position.
10. Turn refill system back on and let run until the hopper is almost full then turn off refill.
11. Allow sanitizer to sit in system for 10 minutes.
12. Drain sanitizer from hopper and remove the Q.C.D. from the sanitizer bucket.
13. Empty remaining sanitizer and refill bucket with about 2 gallons of warm (120-180 deg. F) rinse water.
14. Turn sanitize valve back to dispense position.
15. Place Q.C.D. into rinse water and turn on refill system.
16. Run until hopper is about 1/4 full.
17. Turn off refill system and drain hoppers.
18. Refer to the RECOMMENDED CLEANING instructions and follow these steps to clean the hopper, lid and other dispense parts.

## PREVENTIVE MAINTENANCE

A common problem occurs when the proper preventive maintenance procedures are not followed. Failure to perform these procedures may result in damaged equipment and may not be covered by warranty.

Please check the following items before assuming a refrigeration fault.

When the product does not freeze, there are several possibilities other than a failure in the refrigeration system. The torque between the auger motor and the frozen product is controlled by the torque sensor board measuring the distance between the pins on the coupler and shaft. When the distance between the pins reaches the maximum allowable distance, the compressor shuts off. The machine thinks the product thickness has reached the maximum and shuts off the compressor. The illustration below shows some of the other possible causes for a false reading from the torque sensor board.

Proper inspection and preventive maintenance (including daily cleaning) will avoid expensive repairs and costly down time.

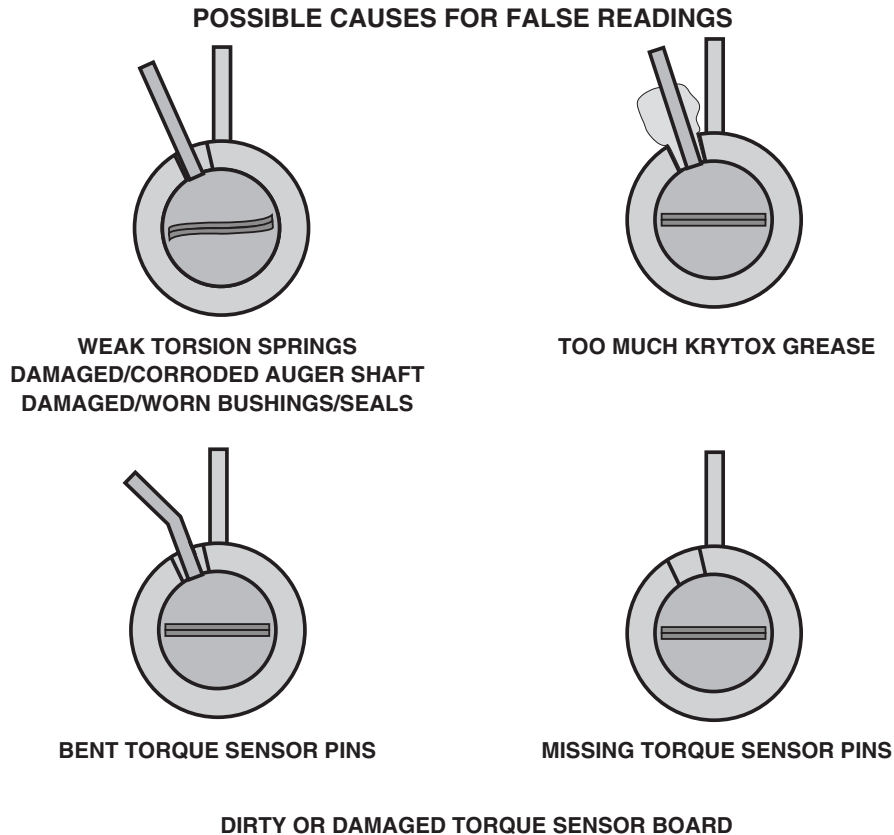
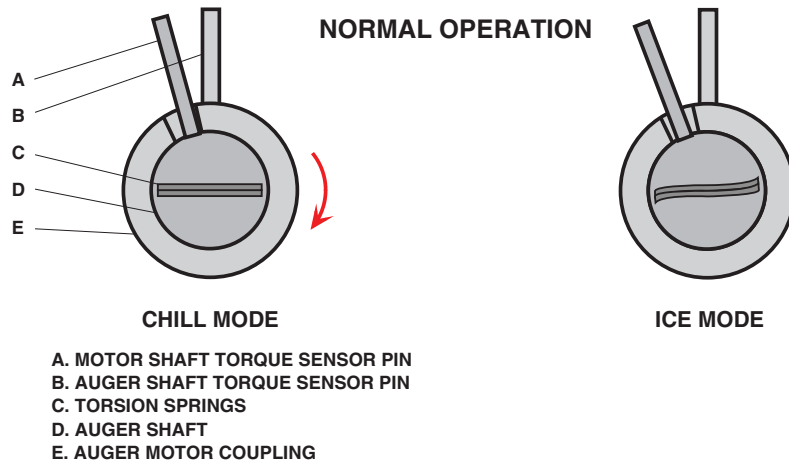

## REQUIRED REGULAR MAINTENANCE

### Semi-annual

BUNN Kit #34245.0000 & #34245.0001 are required to perform the semi-annual preventive maintenance:

**NOTE: Service caused by failure to perform required maintenance is not covered by warranty.**

The following instructions apply to one hopper only; repeat each step for all hoppers.

### Kit Contents

Inventory this kit for completeness before proceeding.

- 34245.0003 PM Kit, ULTRA-2 PAF with LEDs
- 34245.0001 PM Kit, ULTRA-2

Part Number	Quantity	Description
	• ••	
26781.0000	2 3	Auger Shaft Bushing (Blue)
37593.0000	2 3	Cooling Drum Seal
32079.0000	2 3	Hopper/Drum Seal
32268.1000	2 3	Seal Kit, Faucet (Clear)
29563.0000	- -	Lubricant ("Krytox")
28395.0000	1 1	Seal Insertion Tool

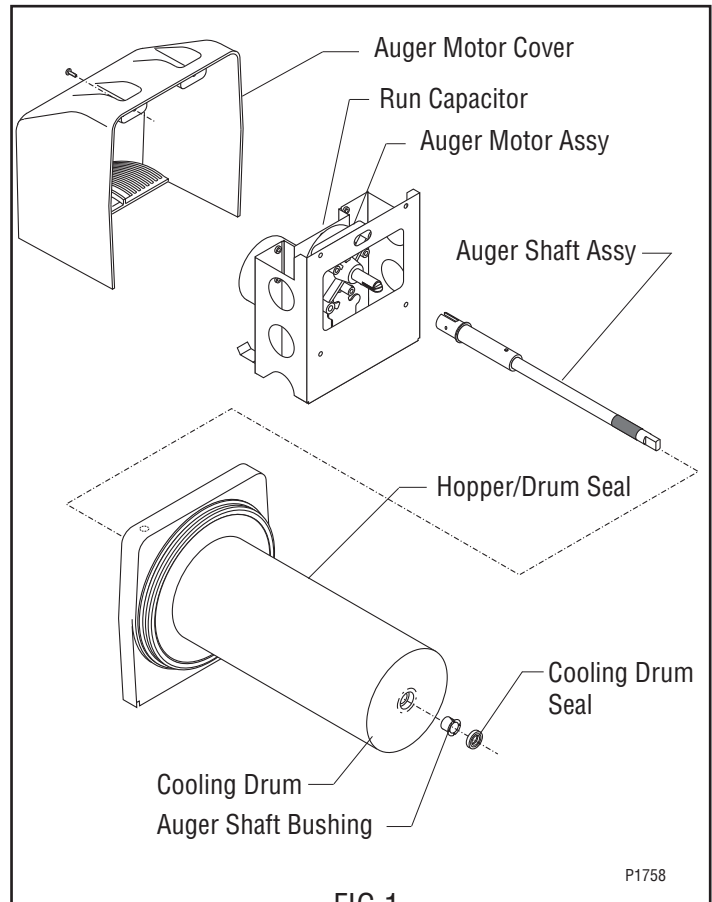

FIG 1

### INSTRUCTIONS

**WARNING** - Disconnect the dispenser from the power source before the removal of any panel or the replacement of any component.

1. Drain, remove and clean hopper; refer to the *Recommended Daily Cleaning* instructions for proper cleaning procedures. Discard the hopper/drum seal and faucet seal.
2. Remove the #8 locking screws securing auger motor cover to the cooling drum mount assembly; remove cover and set aside for reassembly.
3. Remove the #8 locking screw on the lower right side (viewed from front) of the auger motor mounting bracket securing the auger motor run capacitor. Set capacitor aside with wires attached.
4. Disconnect the auger motor terminal from the terminal on the main wiring harness.
5. Remove the remaining #8 locking screws securing the cooling drum mounting bracket. Remove motor with mounting bracket.

**NOTE:** When removing or installing motor and shaft assemblies, be sure the motor and shaft pins are turned to a position that will clear the torque sensor circuit board.

## REQUIRED REGULAR MAINTENANCE (continued)

6. Pull the auger shaft assembly straight out of cooling drum. Inspect the shaft for abnormal wear.
7. From the front of dispenser, remove the seal and blue bushing from cooling drum and discard them.
8. Inspect inside of the cooling drum from the rear for product leakage and clean thoroughly with an extended bristle brush (Bunn part no. 40500.1068) and warm sanitize solution, rinse and dry with a towel. Clean the front seal/bushing area of the cooling drum thoroughly with the bristle brush. Refer to Fig. 4 for areas to be cleaned.
9. Refer to FIG 1, and slip new blue bushing into cooling drum.
10. Place seal on insertion tool #28395.0000 as shown in FIG 2. Make sure open face of seal is toward cooling drum.
11. Apply a small amount of food grade lubricant (Bunn #M2568.1001) to inside diameter of seal. Push seal into bore until it is firmly seated; remove tool.
12. Place a small amount of #29563.0000 “Krytox” lubricant (provided in kit in a plastic cap) on the end of the motor shaft (about 1 1/2”) and a thin film in the groove. Install auger shaft assembly onto the motor shaft. See FIG 3. Do not use too much “Krytox” lubricant. Dirt or grease on pins will cause “optical” misreading by torque sensors.

**NOTE:** This is the only place “Krytox” lubricant is used.

13. Assemble motor/shaft assembly as shown in FIG 3, then install assembly into cooling drum. Make sure the pins do not hit the sensor board and cooling drum seal is not dislodged as the shaft passes through.
14. Secure motor and capacitor to the cooling drum mounting bracket. Install rear motor cover.
15. Refer to the hopper assembly and installation procedures. Install new hopper/drum seals and faucet seals included in the kit. See FIG 1 & 5.
16. Remove and clean condenser air filter. See FIG 6.
17. Refer to the Programming Manual, “Menu Function Index”. Scroll to menu “PM Complete?” and answer “YES” to reset the reminder message “PM Due”.

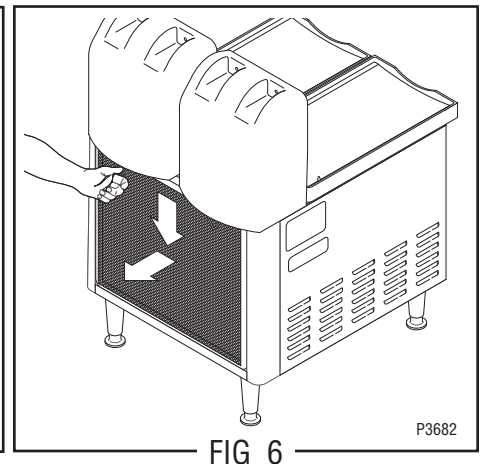
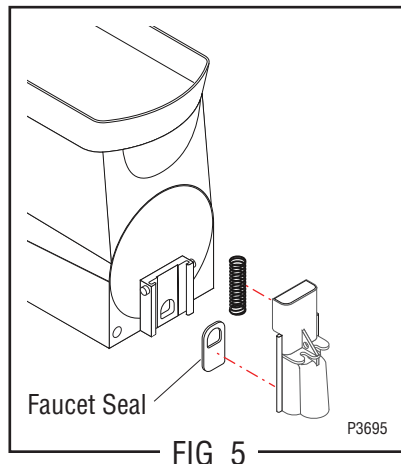
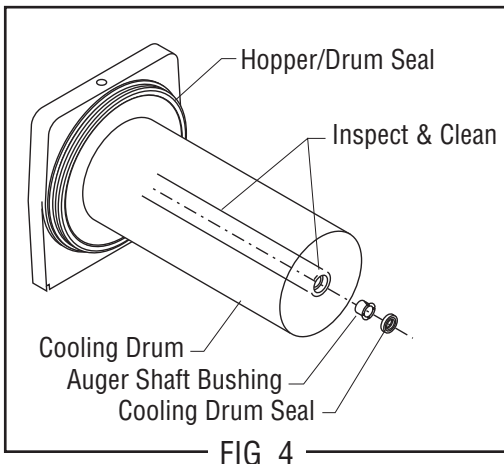
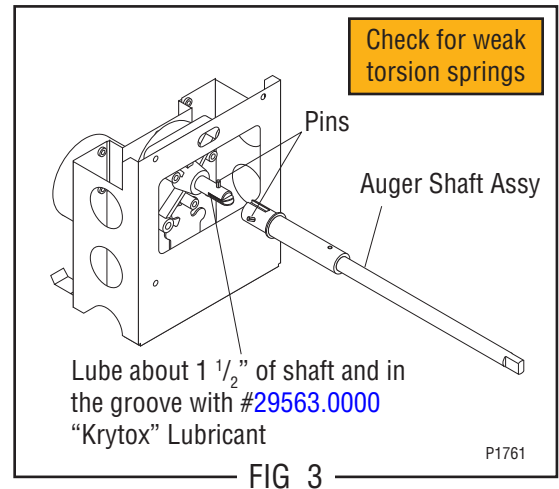
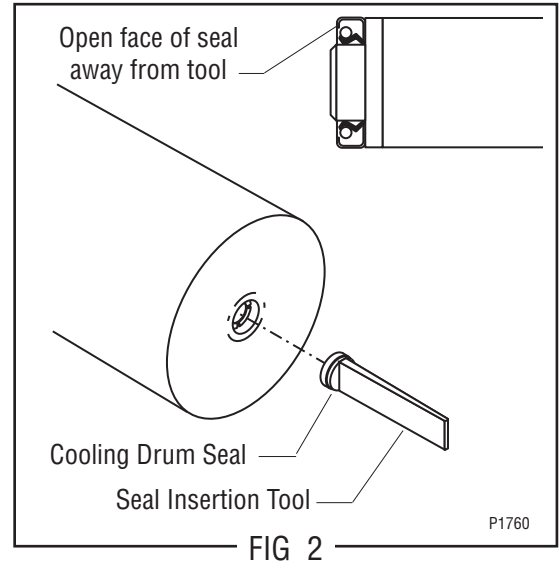

## TROUBLESHOOTING

A troubleshooting guide is provided to suggest probable causes and remedies for the most likely problems encountered. If the problem remains after exhausting the troubleshooting steps, contact the Bunn-O-Matic Technical Service Department.

- Inspection, testing, and repair of electrical equipment should be performed only by qualified service personnel.
- All electronic components have 120 volt ac and/or low voltage dc potential on their terminals. Shorting of terminals or the application of external voltages may result in board failure.
- Intermittent operation of electronic circuit boards is unlikely. Board failure will normally be permanent. If an intermittent condition is encountered, the cause will likely be a switch contact or a loose connection at a terminal or crimp.
- Keep away from combustibles.

- WARNING**
- Exercise extreme caution when servicing electrical equipment.
  - Unplug the dispenser when servicing, except when electrical tests are specified.
  - Follow recommended service procedures
  - Replace all protective shields or safety notices

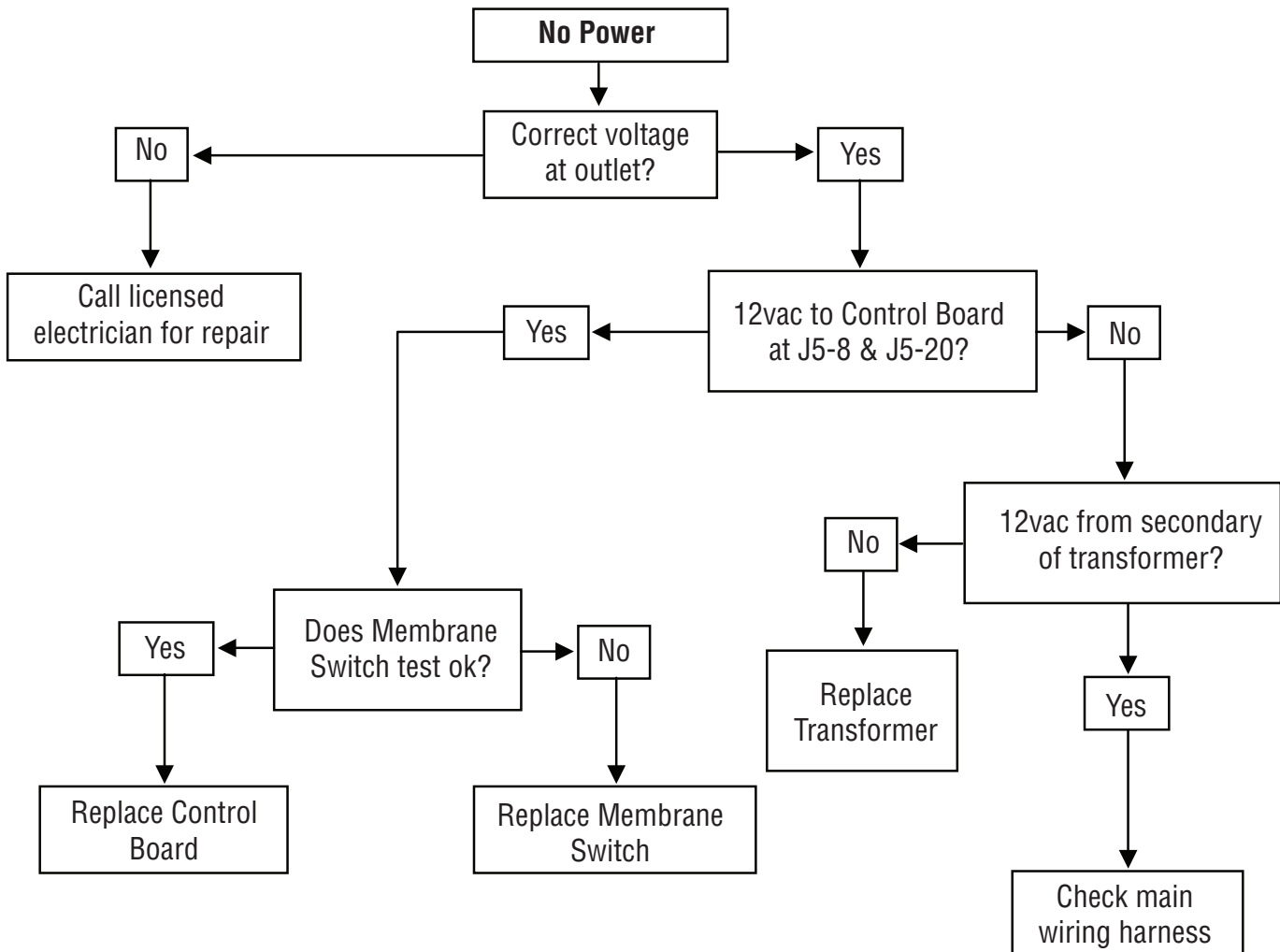

## TROUBLESHOOTING (continued)

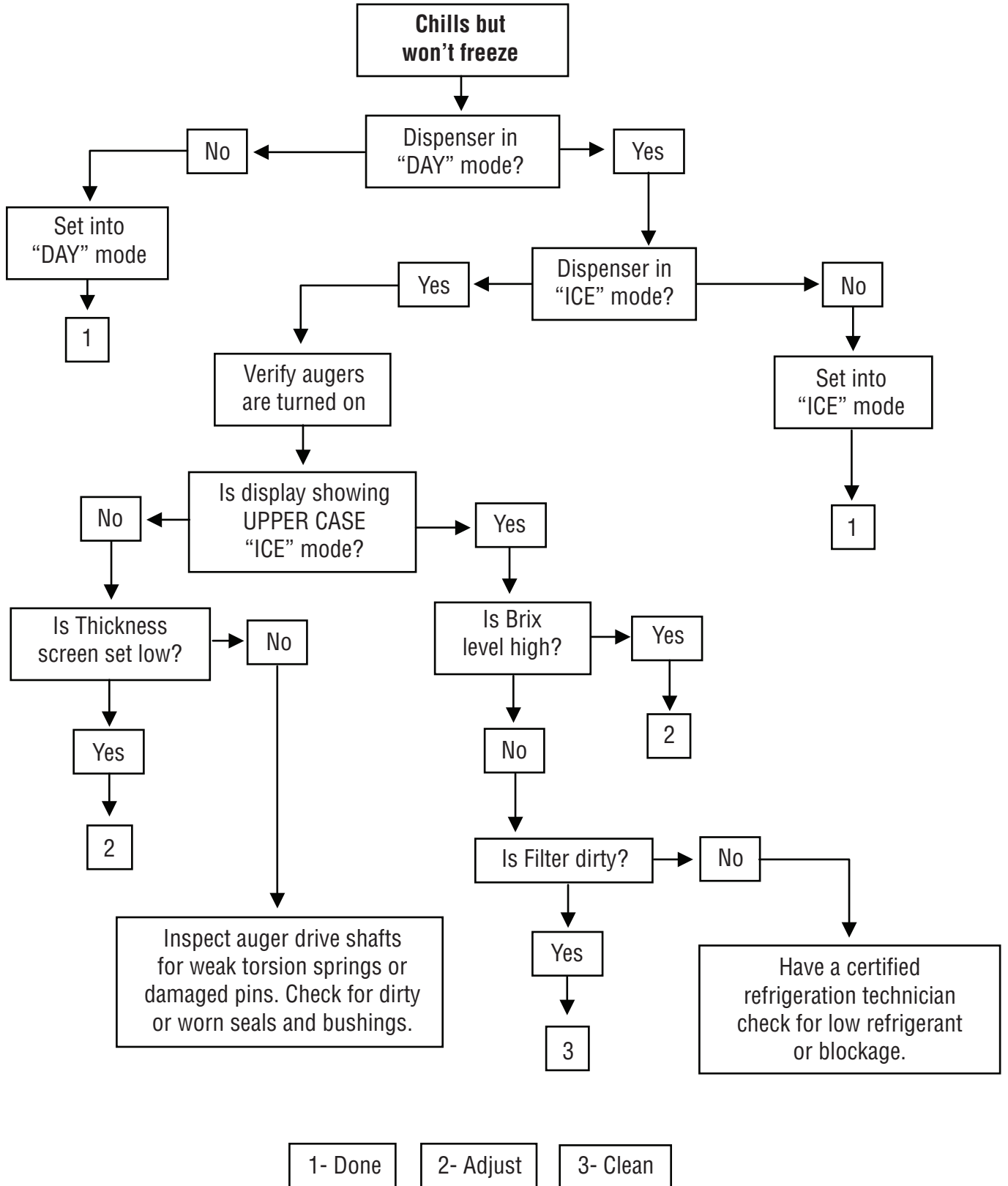

## TROUBLESHOOTING (continued)

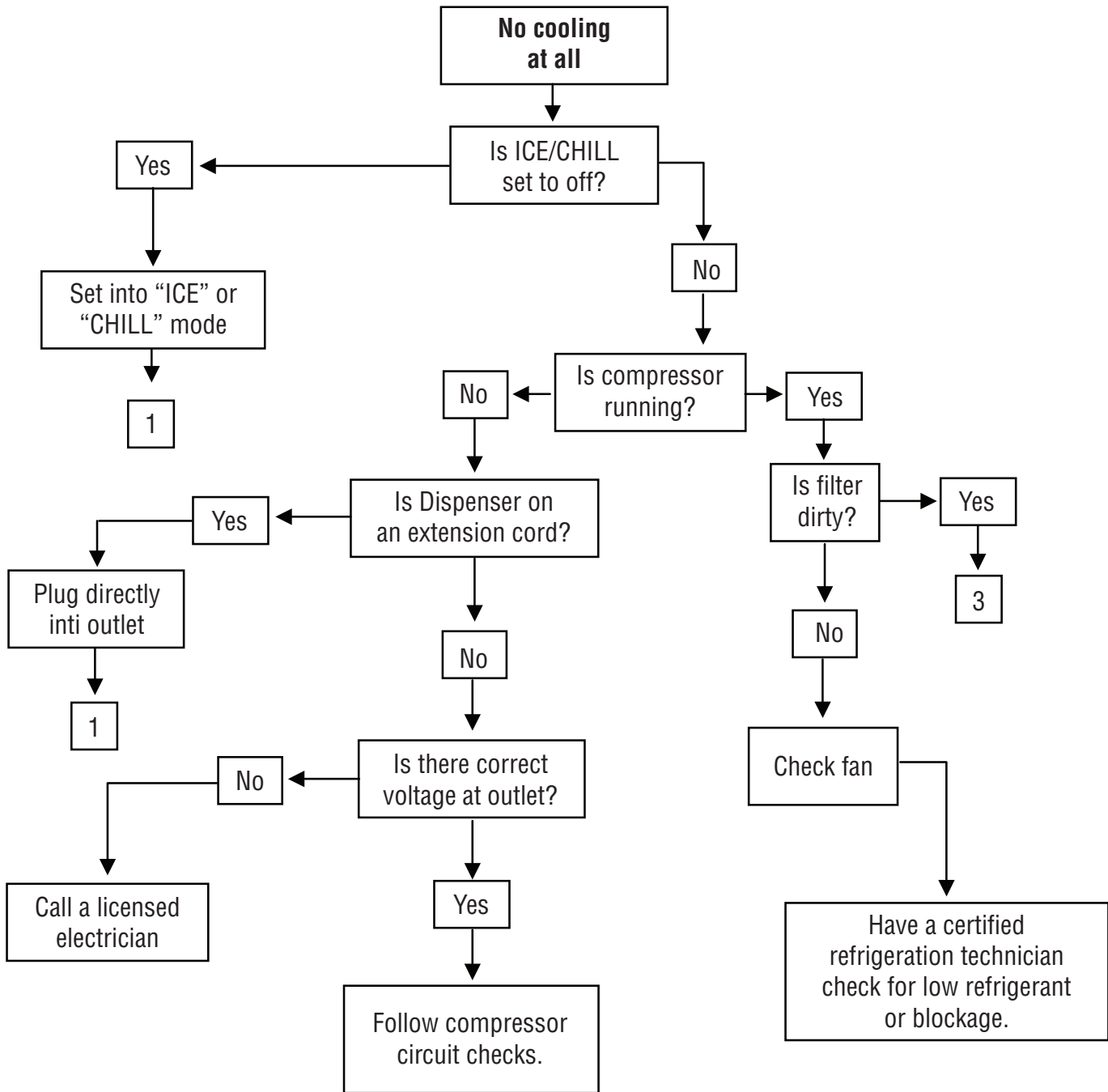

1- Done

2- Adjust

3- Clean

## TROUBLESHOOTING (continued)

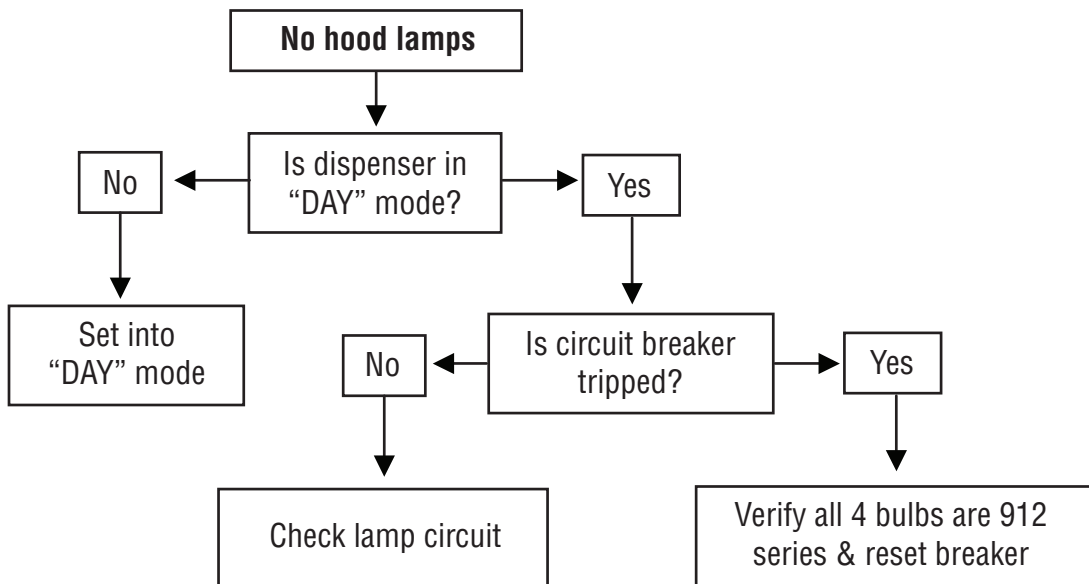
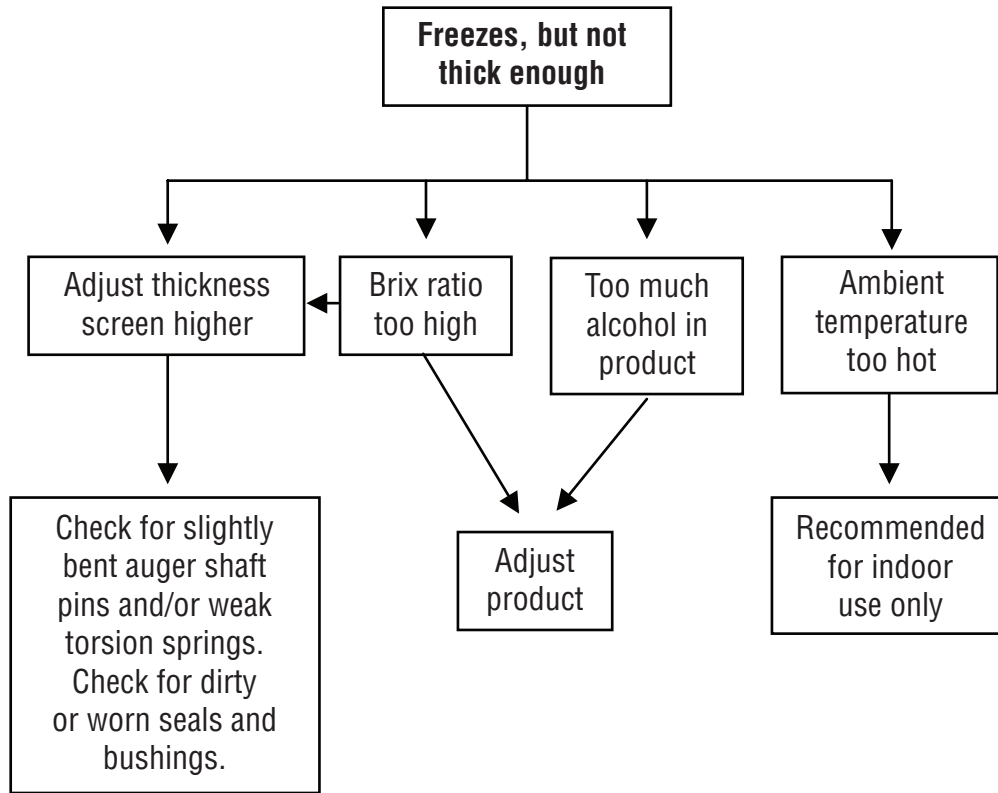

## TROUBLESHOOTING (continued)

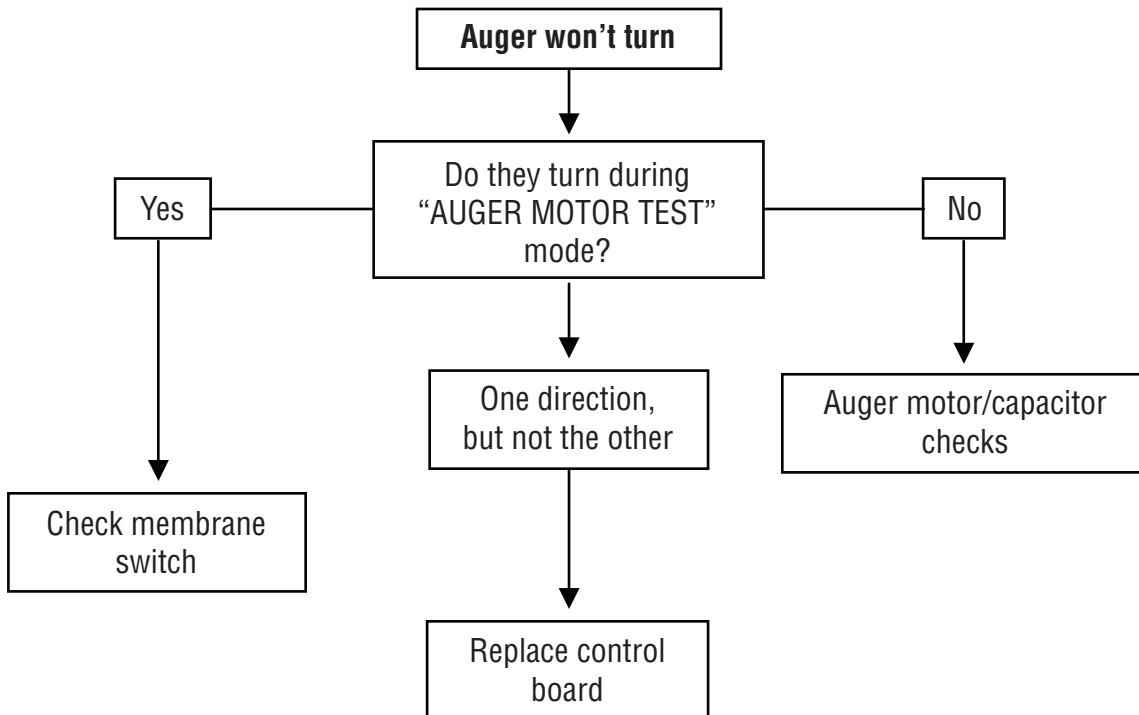
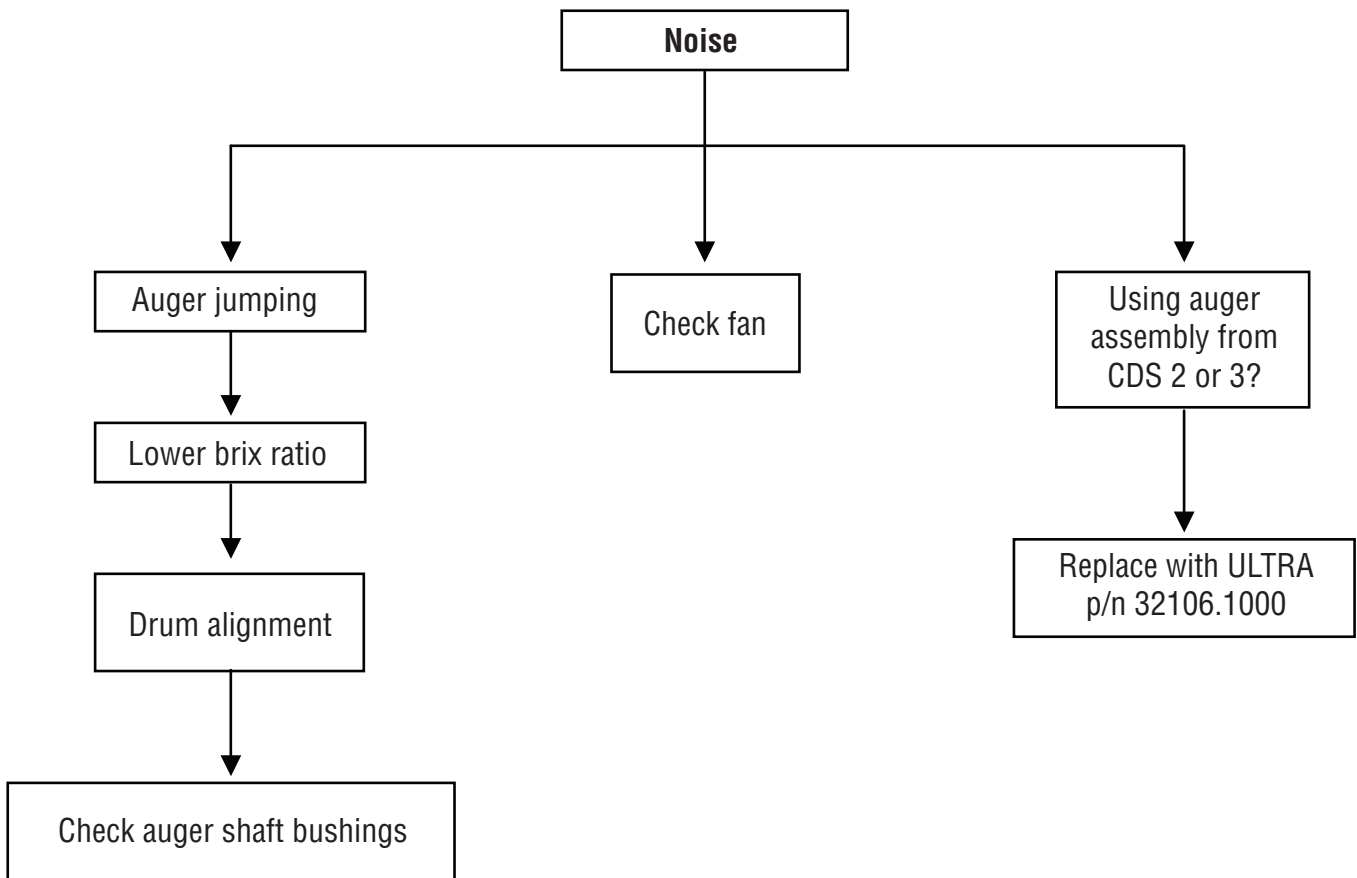

# TROUBLESHOOTING (continued)

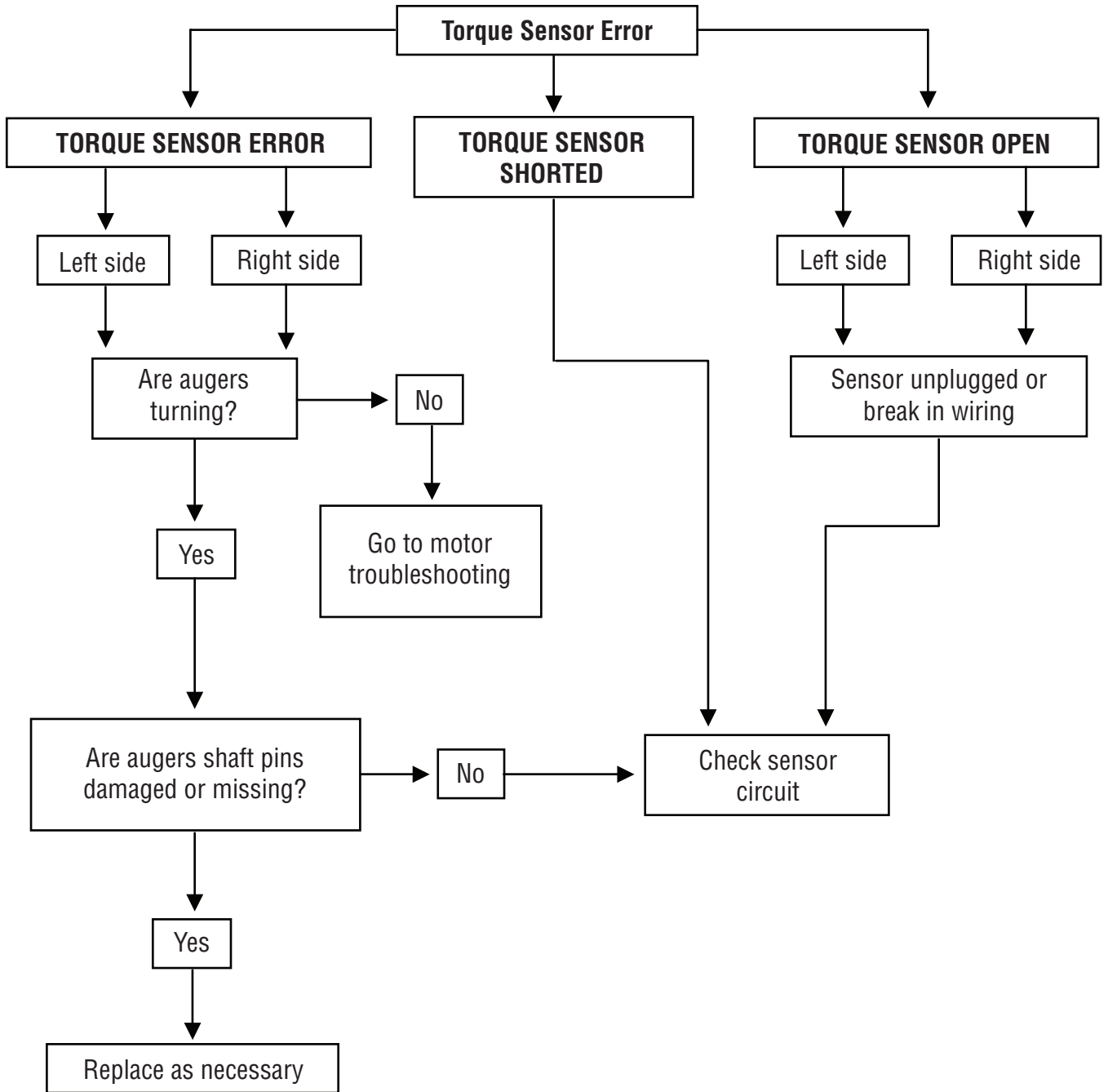

## TROUBLESHOOTING (continued)

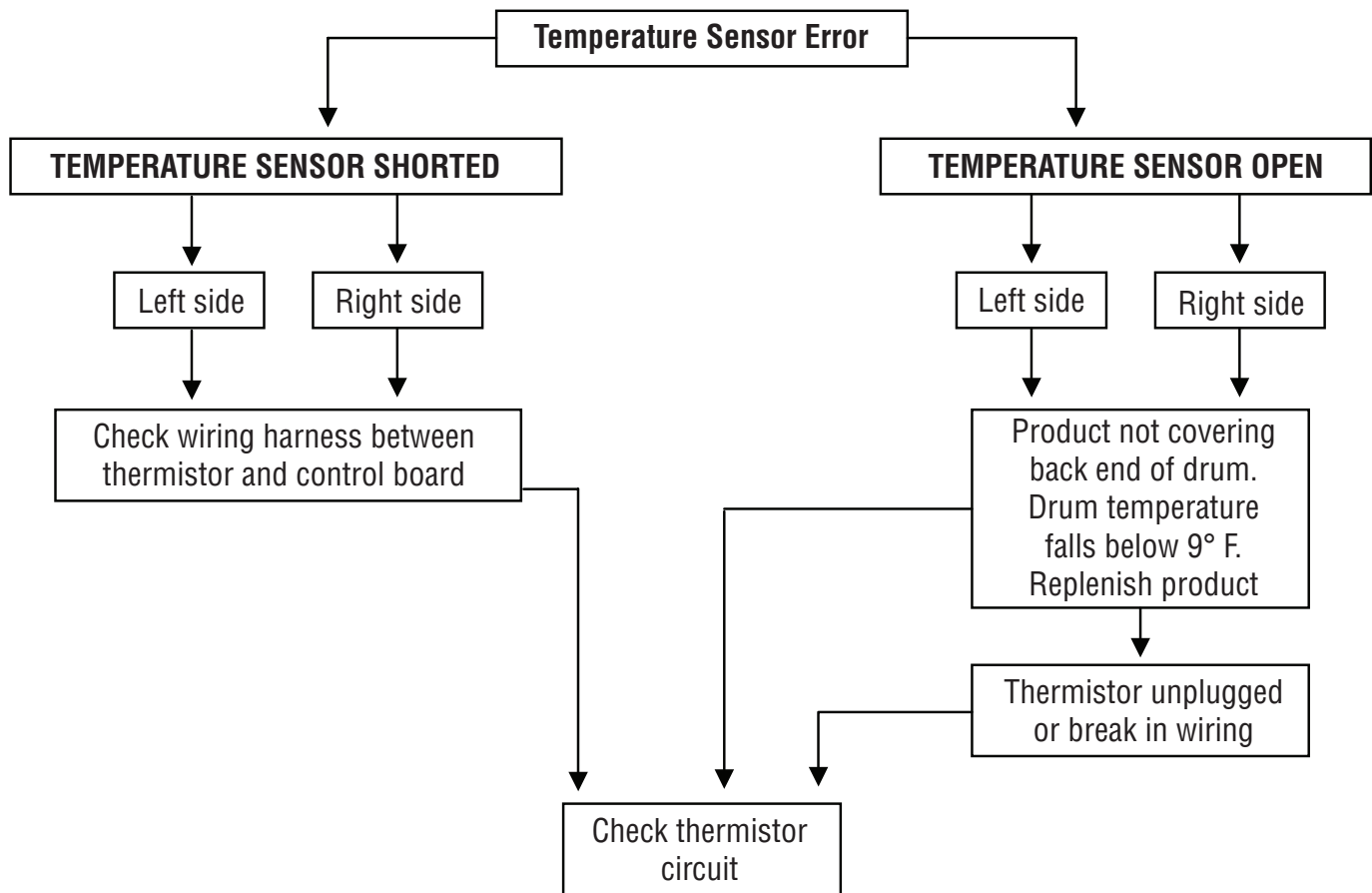

## TROUBLESHOOTING (continued)

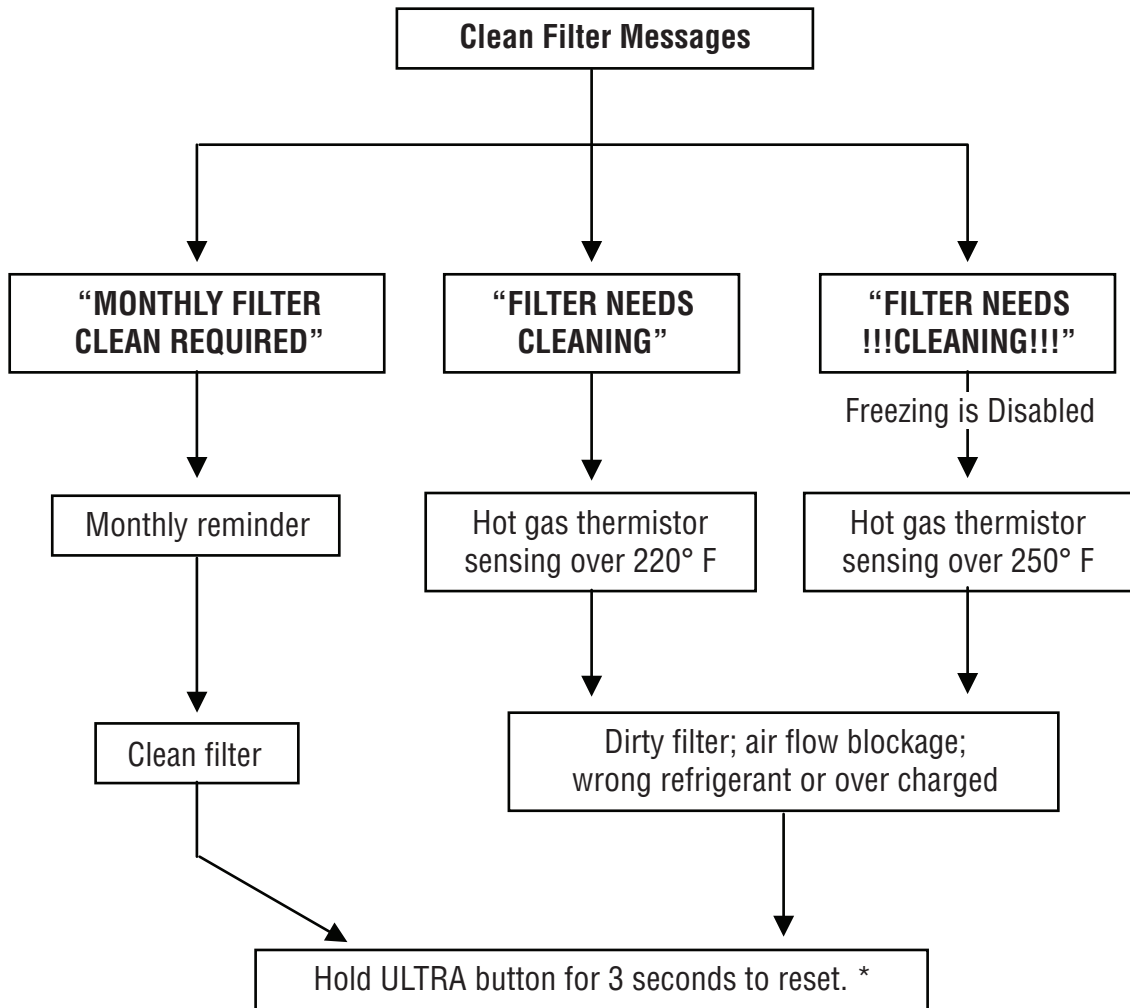

\* Early units have to reset to factory defaults in order to reset

## SERVICE

This section provides procedures for testing and replacing various major components used in this dispenser should service become necessary. Refer to *Troubleshooting* for assistance in determining the cause of any problem.

**WARNING** - Inspection, testing, and repair of electrical equipment should be performed only by qualified service personnel. The dispenser should be disconnected from the power source when servicing, except when electrical tests are required and the test procedure specifically states to connect the dispenser to the power source.

### COMPONENT ACCESS PANELS

**WARNING** - Disconnect the dispenser from the power source before the removal of any panel or the replacement of any component.

All components are accessible by removal of the auger motor cover, lower drip tray, front cover and the left and right side covers.

Refer to the contents listing for component location.

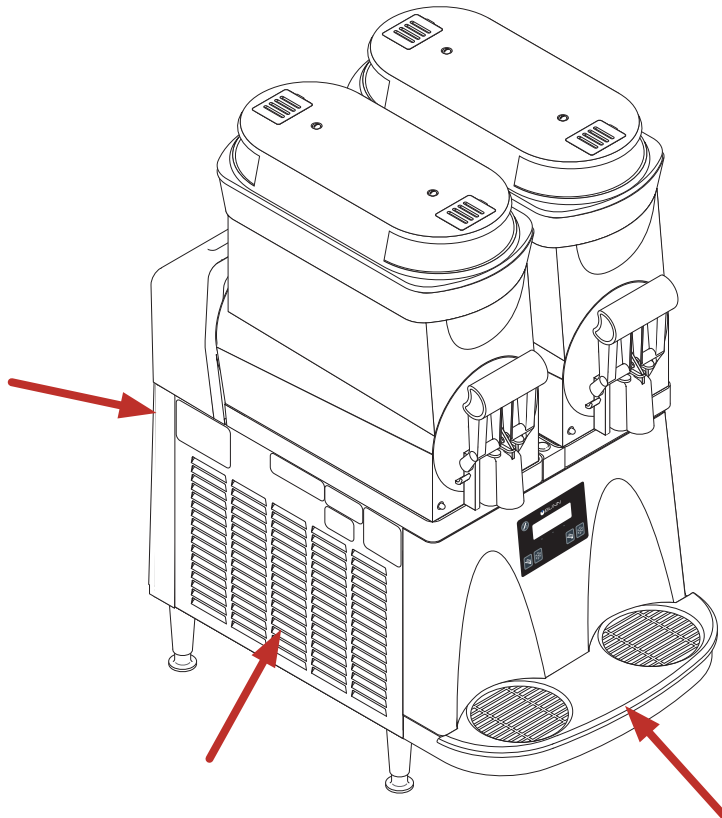

## SERVICE (continued)

### AUGER MOTORS

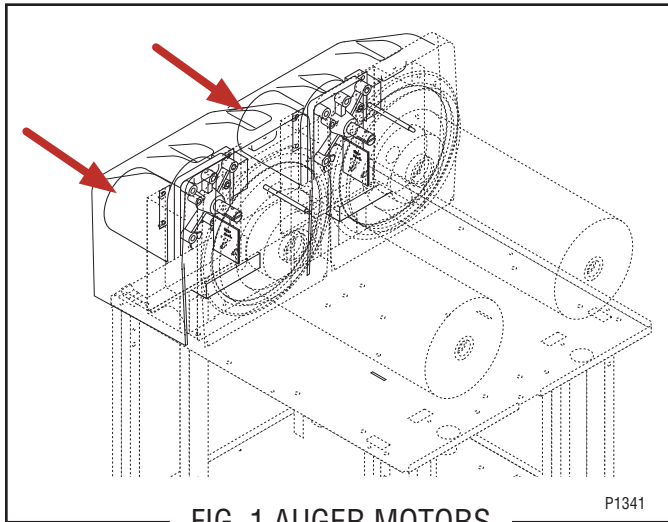

FIG. 1 AUGER MOTORS

#### Location

The auger motors are located at the upper rear of the dispenser chassis inside the auger motor covers.

#### Test Procedures

1. Remove the hopper from the same side as the motor to be tested.
2. Turn "ON" the appropriate auger switch.
3. Nudge the auger to start it turning.

If the auger doesn't turn, replace the motor.

If auger starts to turn, replace the start capacitor.

**WARNING:** The compressor start capacitor must be properly discharged before removing. This is most commonly done on low voltage capacitors by shorting across the terminals with a screwdriver.

#### Removal and Replacement

1. Remove the two #8 locking screws securing the auger motor cover to the cooling drum mount assembly.
2. Remove the cover and set aside for reassembly.
3. Remove the #8 locking screw on the lower right side of the auger motor mounting bracket securing the auger motor run capacitor. Set capacitor aside with wires attached.
4. Disconnect the auger motor terminal from the terminal on the main wiring harness.
5. Remove the three remaining #8 locking screws securing the auger motor mounting bracket to cooling drum mounting bracket.
6. Remove motor with mounting bracket, drip tray, split pin and torsion spring bearing as an assembly.

**NOTE:** When removing or installing the motor be sure the split pin in the motor shaft is turned to a position that will clear the torque sensor circuit board.

7. Install new motor with mounting bracket, drip tray, split pin and torsion spring bearing using three #8 locking screws onto the cooling drum bracket.
8. Install the auger motor capacitor on the lower right side of the auger mounting bracket, using the remaining #8 locking screw.
9. Connect the auger motor terminal to the terminal on the main wiring harness.
10. Refer to Fig. 2 when reconnecting the wires.

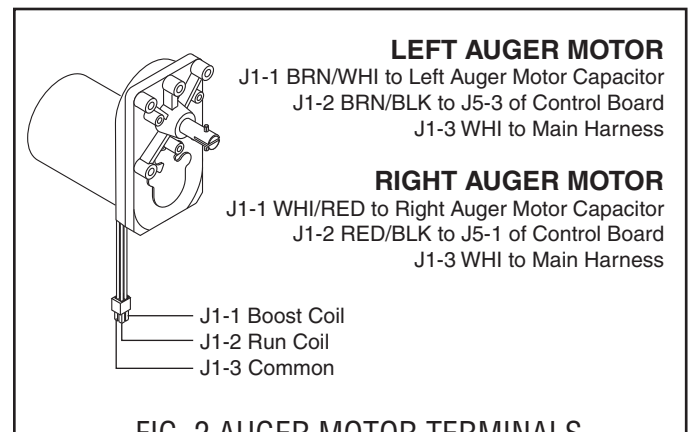

FIG. 2 AUGER MOTOR TERMINALS

#### MOTOR COIL RESISTANCE

J1-3 to: WHITE	J1-1 = 58 ohms BLACK	J1-2 = 58 ohms RED
-------------------	-------------------------	-----------------------

## AUGER MOTOR CAPACITOR

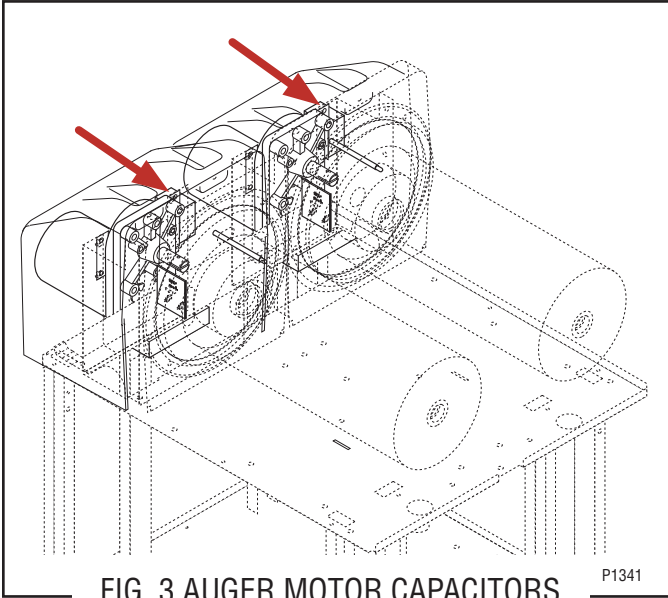

FIG. 3 AUGER MOTOR CAPACITORS

### Location:

The auger motor capacitor(s) are located on the lower right side of the auger motor mounting bracket inside the auger motor cover(s).

### Test Procedures

1. Remove the hopper from the same side as the motor to be tested.
2. Turn "ON" the appropriate auger switch.
3. Nudge the auger to start it turning.

If the auger doesn't turn, replace the motor.

If auger starts to turn, replace the start capacitor.

**WARNING:** The compressor start capacitor must be properly discharged before removing. This is most commonly done on low voltage capacitors by shorting across the terminals with a screwdriver.

### Removal and Replacement

1. Remove the two #8 locking screws securing the auger motor cover to the cooling drum mount assy.
2. Remove the cover and set aside for reassembly.
3. Disconnect the wires from the auger motor capacitor terminals.
4. Remove the #8 locking screw on the lower right side of the auger motor mounting bracket securing the auger motor capacitor.
5. Install a new capacitor on the lower right side of the auger mounting bracket and secure with a #8 locking screw.
6. Reconnect the wires to the capacitor terminals.
7. Refer to Fig. 4 when reconnecting the wires.

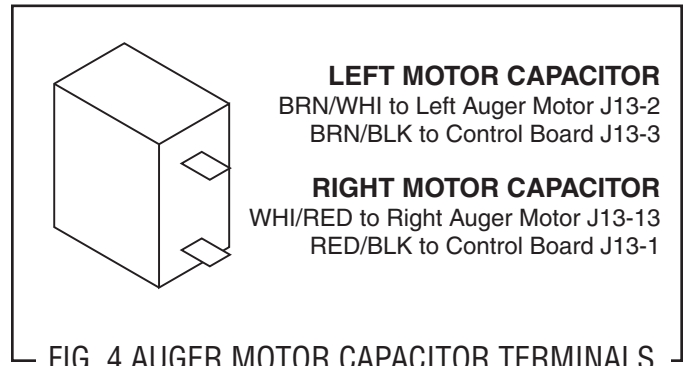
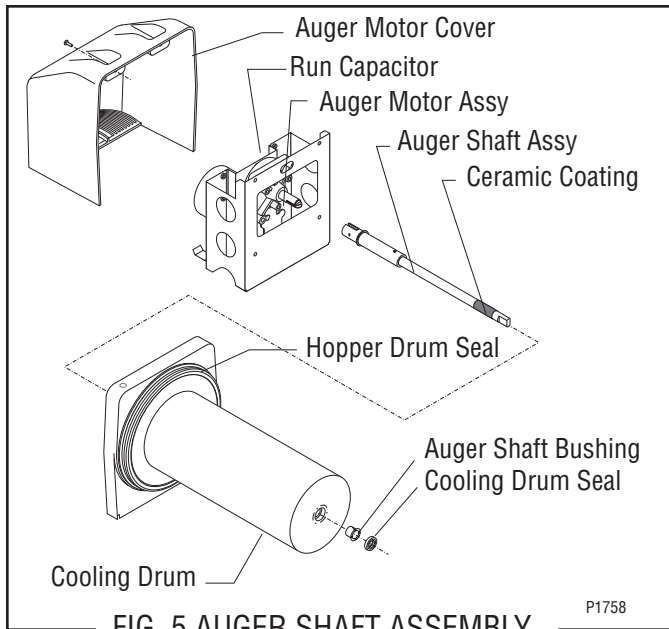

FIG. 4 AUGER MOTOR CAPACITOR TERMINALS

## SERVICE (continued)

### AUGER SHAFT ASSEMBLY



#### Location:

The Auger Shaft Assembly is located in each of the cooling drums.

#### Removal and Replacement:

1. Drain, remove and clean hopper; refer to the *Recommended Daily Weekly Cleaning* Section of this manual, for proper cleaning procedures. Discard the hopper/drum seal and faucet seal.
2. Remove the #8 locking screws securing auger motor cover to the cooling drum mount assembly; remove cover and set aside for reassembly.
3. Remove the #8 locking screw on the lower right side (viewed from front) of the auger motor mounting bracket securing the auger motor run capacitor. Set capacitor aside with wires attached.
4. Disconnect the auger motor terminal from the terminal on the main wiring harness.
5. Remove the remaining #8 locking screws securing the auger motor mounting bracket to cooling drum mounting bracket.
6. Remove motor with mounting bracket, split pin and torsion spring bearing as an assembly.

**NOTE** - When removing or installing motor and shaft assemblies, be sure the split pins are turned to a position that will clear the torque sensor circuit board.

7. Pull the auger shaft assembly straight out of cooling drum. Inspect the shaft for abnormal wear or scoring.
8. From the front of dispenser, remove the seal and blue bushing from cooling drum and discard them.
9. Clean seal and bushing surfaces of the cooling drum very thoroughly.
10. Refer to Fig 6 and slip new blue bushing into cooling drum.

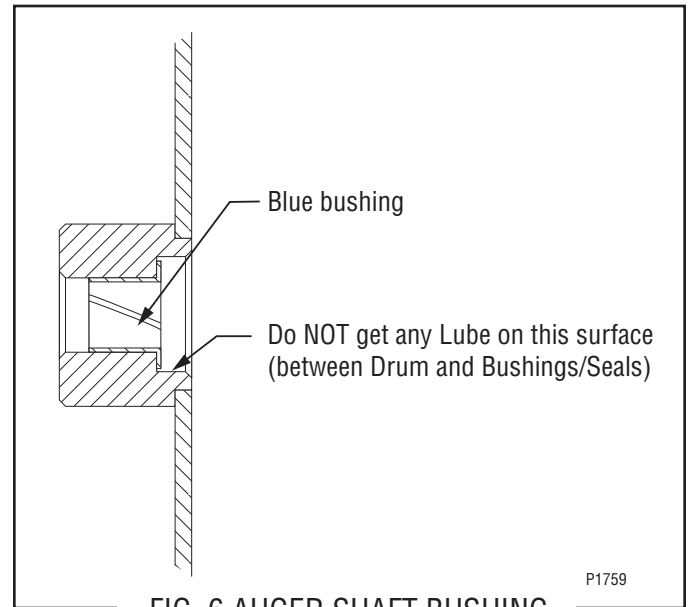

11. Place seal on insertion tool #28395.0000, as shown in Fig. 7. Make sure open face of seal is toward cooling drum.
12. Push seal into bore until it is firmly seated; remove tool.
13. Place a small amount of #29563.0000 “Krytox” lubricant (provided in kit in a plastic cap) on the end of the motor shaft (about 1 1/2”) and a thin film in the groove. Install auger shaft assembly onto the motor shaft. See Fig. 8. Do not use too much “Krytox” lubricant.

**NOTE** - This is the only place “Krytox” lubricant is used.

**AUGER SHAFT ASSEMBLY (cont.)**

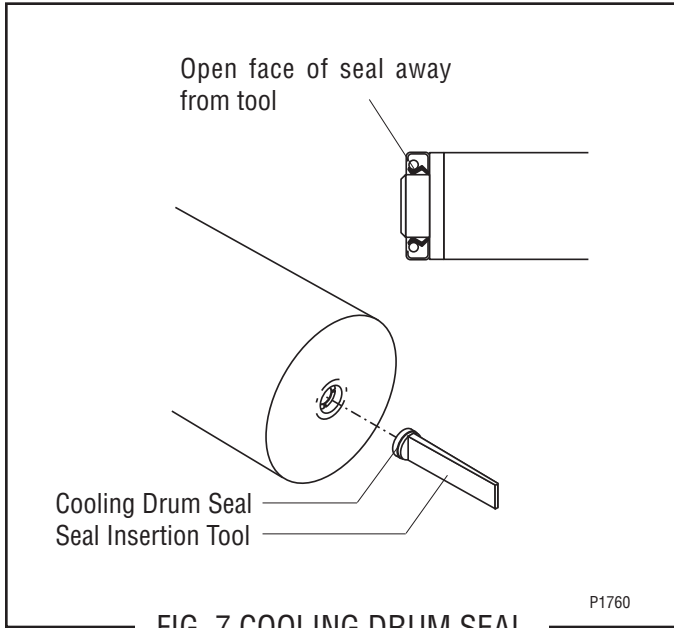

FIG. 7 COOLING DRUM SEAL

14. Assemble motor/shaft assembly as shown in Fig. 8, then install assembly into cooling drum. Make sure the pins do not hit the sensor board and cooling drum seal is not dislodged as the shaft passes through.

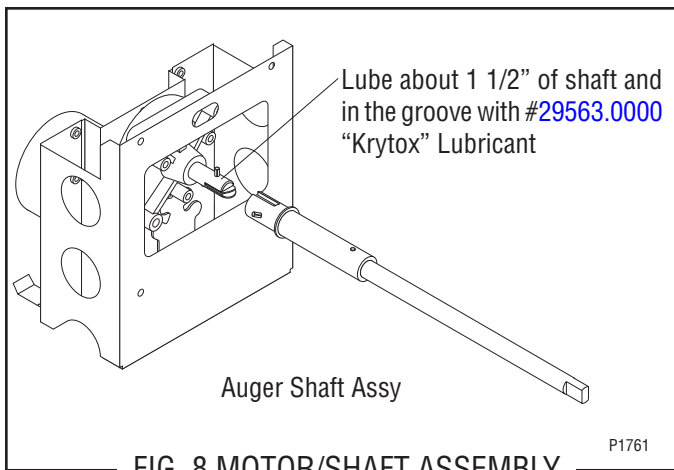

FIG. 8 MOTOR/SHAFT ASSEMBLY

15. Secure motor and capacitor to the cooling drum mounting bracket. Install rear motor cover.

16. Refer to *Hopper Installation* for hopper assembly and installation procedures. Be sure to use new hopper/drum seal and faucet seals

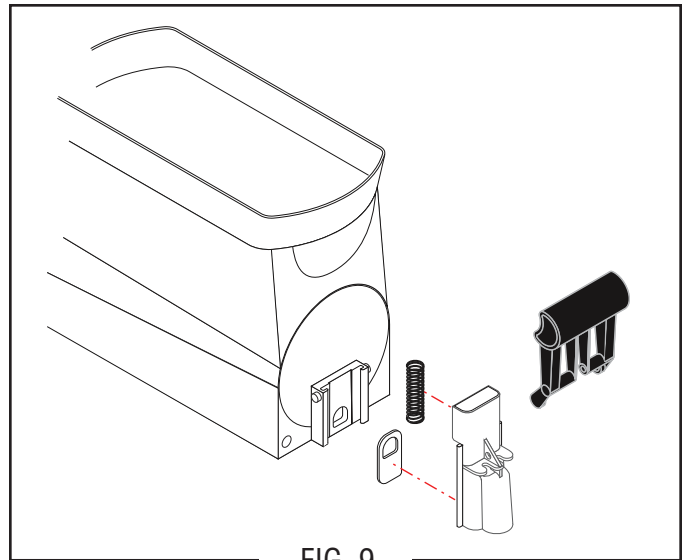

FIG 9

17. Remove and clean condenser air filter, Fig. 10.

18. Refer to the Programming Manual, "Menu Function Index". Scroll to menu "PM Complete?" and answer "YES" to reset the reminder message "PM Due".

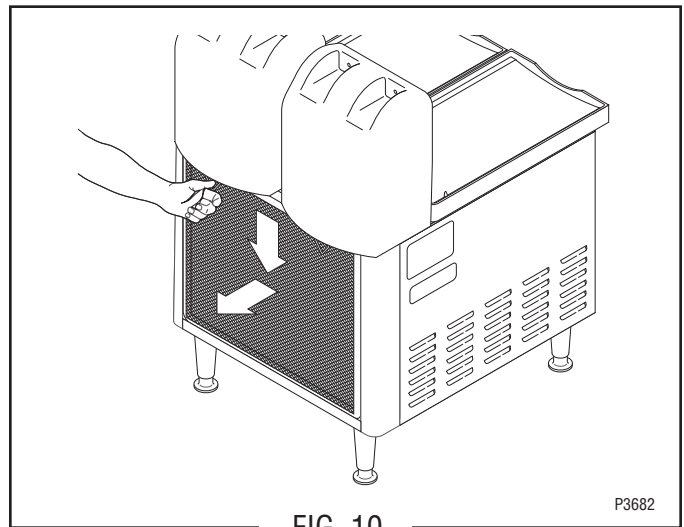

FIG 10

## CIRCUIT BREAKER

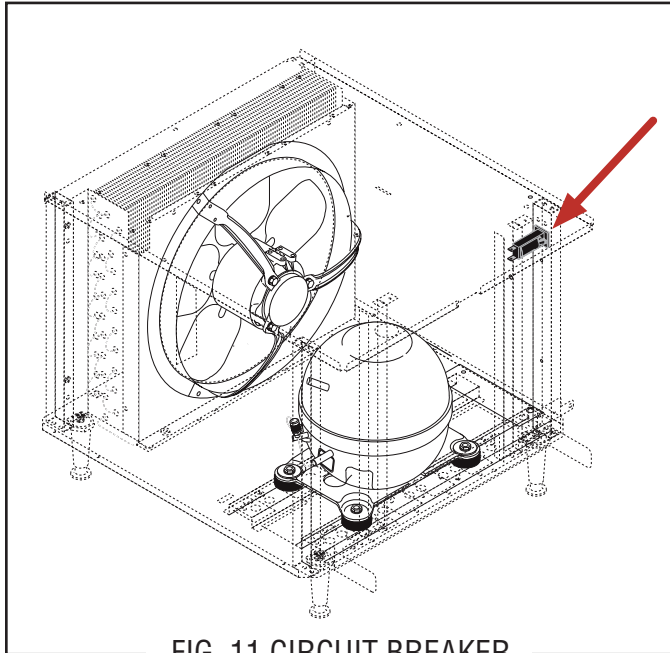

FIG. 11 CIRCUIT BREAKER

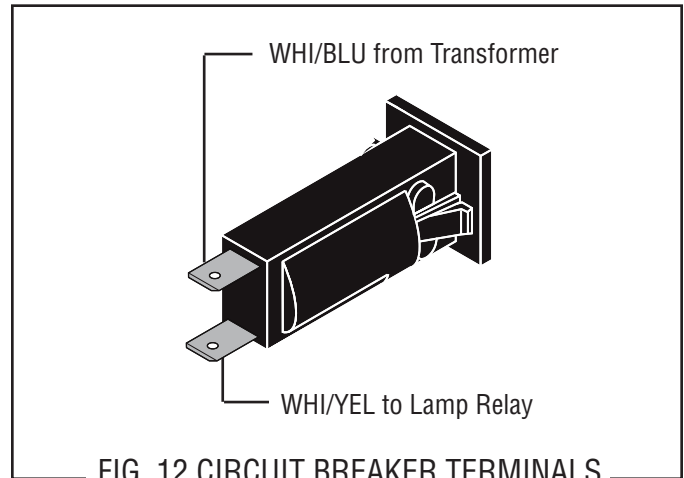

FIG. 12 CIRCUIT BREAKER TERMINALS

### Location:

The circuit breaker is located inside the dispenser on the front right frame post.

### Test Procedures:

1. Disconnect the dispenser from the power source.
2. Remove the wires from the circuit breaker.
3. Check for continuity between the terminals. Continuity must be present between the terminals.

If continuity is present as described the circuit breaker is functioning properly.

If continuity is not present as described, press the reset button and repeat step #3, if continuity is not present as described, replace the circuit breaker.

### Removal and Replacement:

1. Remove the right side panel.
2. Remove the wires from the circuit breaker.
3. Compress the clips on the back side of the component bracket and gently push the circuit breaker through the opening in the bracket.
4. Push the new circuit breaker into the opening in the bracket until the clips snap into position.
5. Reconnect the wires to the circuit breaker.
6. Refer to Fig. 12 when reconnecting the wires.

## SERVICE (continued)

### COMPRESSOR (AMERICOLD)

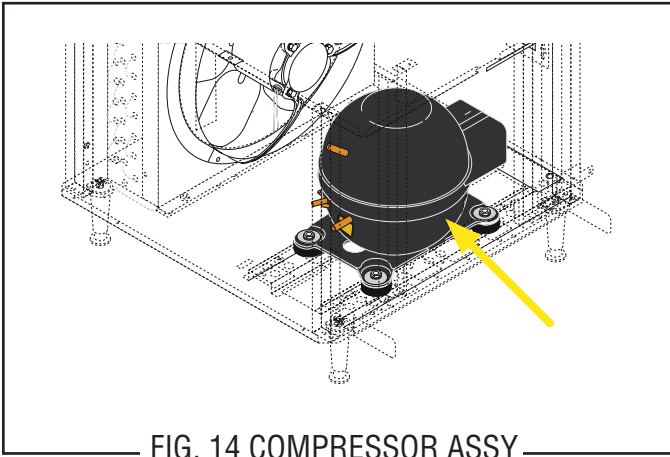

FIG. 14 COMPRESSOR ASSY

#### Location:

The compressor assy is located inside the front of the dispenser chassis.

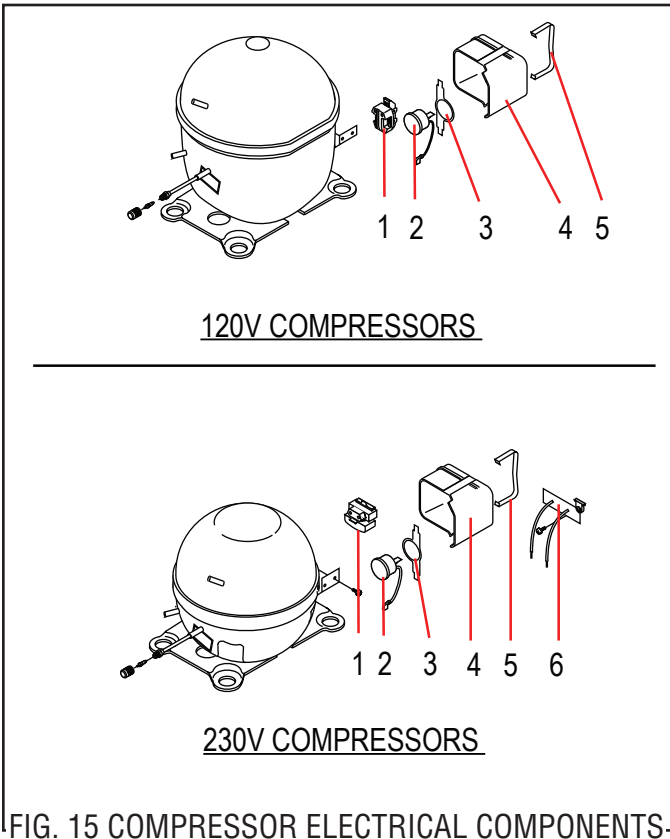

FIG. 15 COMPRESSOR ELECTRICAL COMPONENTS

1. Compressor Start Relay
2. Thermal Overload Protector
3. Overload Protector Retainer
4. Compressor Terminal Cover
5. Terminal Cover Retainer
6. Compressor Run Capacitor

#### Test Procedures:

**WARNING:** The compressor start capacitor must be properly discharged before proceeding. This is most commonly done on low voltage capacitors by shorting across the terminals with a screwdriver.

#### Compressor Start Relay: Refer to FIG. 15

1. Disconnect the dispenser from the power source.
2. Remove compressor terminal cover retainer (5) and compressor terminal cover (4).
3. Connect a voltmeter across the white wire and the white/orange wire. Connect the dispenser to the power source. Verify the dispenser is in "ICE" or "CHILL" mode.

The indication must be:

- (a) 120 volts ac for two wire 120 volt models or
- (b) 230 volts ac for two wire 230 volt models.

5. Disconnect the dispenser from the power source.

If voltage is present as described, proceed to the following test procedures.

If voltage is not present as described, refer to the *Relay* and check the relay.

6. Disconnect the two black wires from the compressor start relay.
7. Remove relay from the compressor.
8. Check for continuity across the upper left terminal and the right pin socket on the rear of the relay.

If continuity is present as described, the compressor start relay is operating properly.

If continuity is not present as described, replace relay.

#### Compressor:

1. With the compressor start relay (1) removed, disconnect the black wire from the compressor.
2. Check for continuity across the terminal on the compressor and the left pin on the compressor.

If continuity is present as described, the electrical part of the compressor is operating properly.

If continuity is not present as described, replace the compressor.

#### Thermal Overload Protector:

1. Check for continuity across the terminals on the thermal overload protector (2).

If continuity is present as described, the thermal overload protector is operating properly.

If continuity is not present as described, replace the thermal overload protector.

## SERVICE (continued)

### COMPRESSOR (AMERICOLD) (cont.)

#### Removal and Replacement:

#### Compressor Start Relay: Refer to FIG. 15

1. Remove the terminal cover retainer (5) and the terminal cover (4)
2. Disconnect the wires from the compressor start relay.
3. Pull relay (1) off of the compressor pins and discard.
4. Push new relay onto the compressor pins.
5. Refer to Fig. 16 and reconnect the wires.
6. Reinstall terminal cover (4) and cover retainer (5).

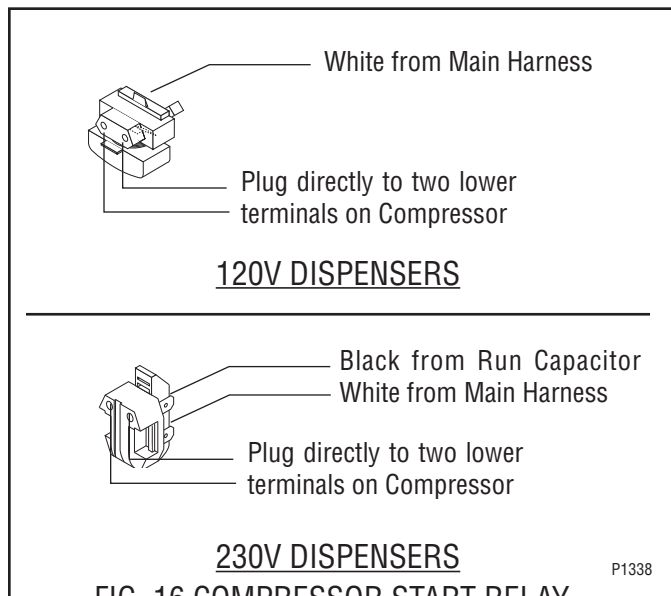

FIG. 16 COMPRESSOR START RELAY  
TERMINALS

#### Compressor Thermal Overload Protector: Refer to FIG. 15

1. Remove terminal cover retainer (5) and terminal cover (4).
2. Disconnect the WHI/ORN wire of the harness from the thermal overload protector.
3. Disconnect the BLK wire from the Compressor's upper terminal.
4. Remove overload protector retainer (3) and thermal overload protector (2) as an assembly.
5. Remove retainer (3) from overload protector (2) and discard overload protector.

6. Install retainer (3) on new overload protector (2).
7. Install retainer (3) and overload protector (2) on the compressor terminal bracket.
8. Refer to Fig. 17 and reconnect the thermal overload protector wires.
9. Reinstall terminal cover (4) and cover retainer (5).

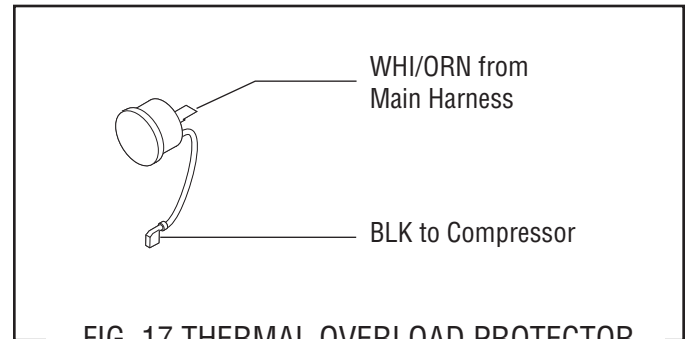

FIG. 17 THERMAL OVERLOAD PROTECTOR  
TERMINALS

#### Compressor Run Capacitor (230V Dispensers Only):

#### Refer to FIG. 15

1. Remove terminal cover retainer (5) and terminal cover (4).
2. Disconnect the run capacitor leads.
3. Remove the #6 crimpite screw securing the run capacitor to the rear of the component bracket.
4. Remove run capacitor and discard.
5. Place new run capacitor on the rear of component bracket and secure with #6 crimpite screw.
6. Refer to Fig. 18 and reconnect the wires.

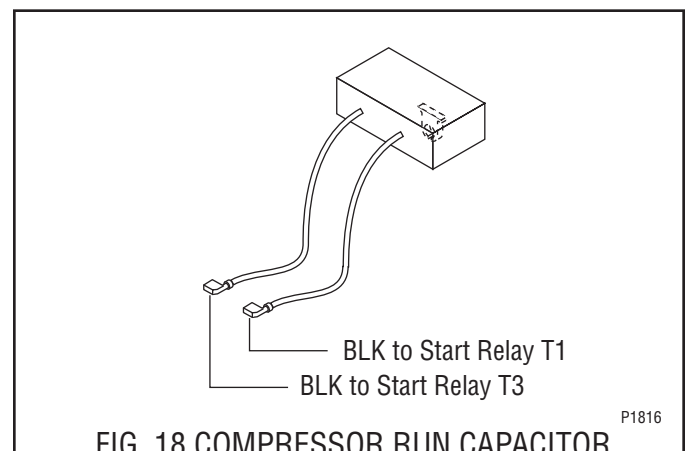

FIG. 18 COMPRESSOR RUN CAPACITOR  
TERMINALS

## SERVICE (continued)

### COMPRESSOR (AMERICOLD) (cont.)

#### Removal and Replacement:

#### Compressor Assy:

**NOTE:** Before removal of any refrigeration component the refrigerant in the system must be reclaimed by a licensed refrigeration repair person.

**NOTE:** When replacing the compressor it is recommended that the dryer also be replaced.

1. Disconnect the tubes from the condenser and the accumulator.
2. Disconnect the compressor wiring harness from the dispenser main wiring harness.
3. Remove the four .25-20 keps nuts and washers securing the compressor to the chassis. Set nuts and washers aside for reassembly.
4. Disconnect and remove the transformer.
5. From the right side of the dispenser lift the compressor assembly over the four studs in the chassis and remove compressor.
6. Install new compressor over the four studs in the dispenser chassis with the fill valve to the left side of the dispenser.
7. Secure compressor to the dispenser chassis using four .25-20 keps nuts and washers.
8. Reconnect tubes from the condenser and the accumulator to the compressor.
9. Reinstall transformer.
10. Evacuate the system.
11. Recharge 120V system with 10 oz. of Type 404A refrigerant. Design Pressures: High 240 - Low 34  
Recharge 230V system with 9.5 oz. of Type 404A refrigerant. Design Pressures: High 215 - Low 40

**NOTE:** The charging of the system must be done by a licensed refrigeration repair person.

**NOTE:** Refer to Wiring Diagrams when reconnecting wires to Compressor, Thermal Overload Protector, Start Relay, and Run Capacitor.

## SERVICE (continued)

### COMPRESSOR (EMBRACO)

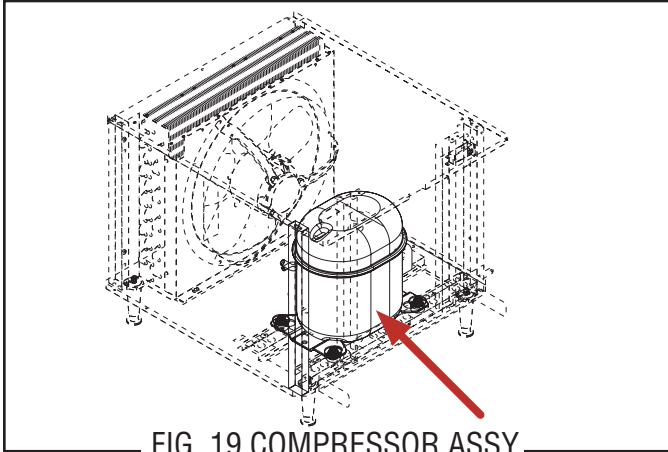

FIG. 19 COMPRESSOR ASSY

#### Location:

The compressor assy is located inside the front of the dispenser chassis.

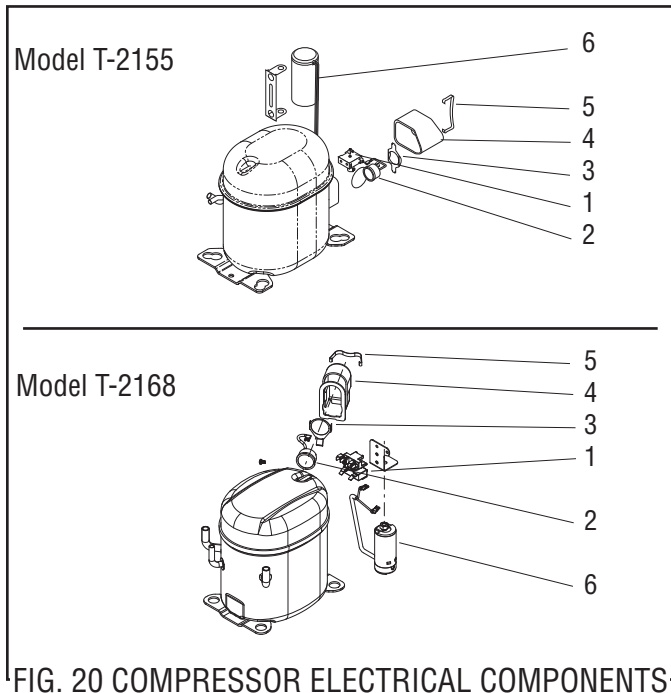

FIG. 20 COMPRESSOR ELECTRICAL COMPONENTS

1. Compressor Start Relay
2. Thermal Overload Protector
3. Overload Protector Retainer
4. Compressor Terminal Cover
5. Terminal Cover Retainer
6. Compressor Run Capacitor

#### Test Procedures:

**WARNING:** The compressor start capacitor must be properly discharged before proceeding. This is most commonly done on low voltage capacitors by shorting across the terminals with a screwdriver.

#### Compressor Start Relay: Refer to FIG. 20

1. Disconnect the dispenser from the power source.
2. Remove compressor terminal cover retainer (5) and compressor terminal cover (4).
3. Connect a voltmeter across the white wire and the white/orange wire. Connect the dispenser to the power source. Verify the dispenser is in "ICE" or "CHILL" mode.

The indication must be:

- (a) 120 volts ac for two wire 120 volt models or
- (b) 230 volts ac for two wire 230 volt models.

5. Disconnect the dispenser from the power source.

If voltage is present as described, proceed to the following test procedures.

If voltage is not present as described, refer to the *Relay* and check the relay.

6. Disconnect the two black wires from the compressor start relay.
7. Remove relay from the compressor.
8. Check for continuity across the upper left terminal and the right pin socket on the rear of the relay.

If continuity is present as described, the compressor start relay is operating properly.

If continuity is not present as described, replace relay.

#### Compressor:

1. With the compressor start relay (1) removed, disconnect the black wire from the compressor.
2. Check for continuity across the terminal on the compressor and the left pin on the compressor.

If continuity is present as described, the electrical part of the compressor is operating properly.

If continuity is not present as described, replace the compressor.

#### Thermal Overload Protector:

1. Check for continuity across the terminals on the thermal overload protector (2).

If continuity is present as described, the thermal overload protector is operating properly.

If continuity is not present as described, replace the thermal overload protector.

## SERVICE (continued)

### COMPRESSOR (EMBRACO) (cont.)

#### Removal and Replacement:

##### Compressor Start Relay: Refer to FIG. 20

1. Disconnect the wires from the compressor start relay.
3. Pull relay (1) off of the compressor pins and discard.
4. Push new relay onto the compressor pins.
5. Refer to Fig. 21 and reconnect the wires.
6. Reinstall terminal cover (4) and cover retainer (5).

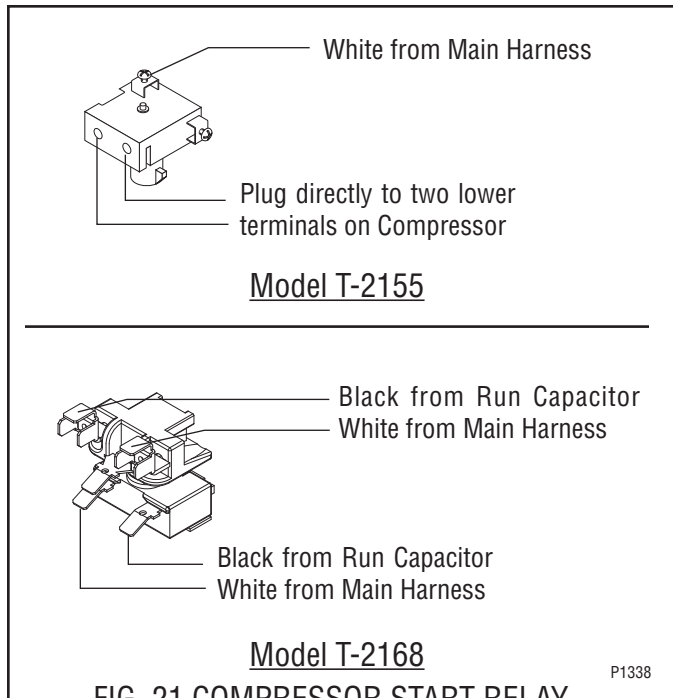
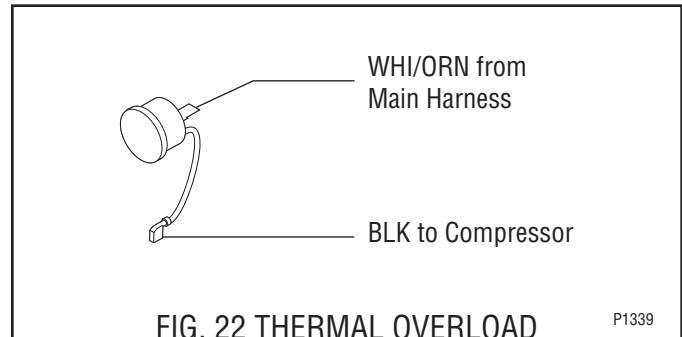

FIG. 21 COMPRESSOR START RELAY TERMINALS

##### Compressor Thermal Overload Protector: Refer to FIG. 20

1. Remove terminal cover retainer (5) and terminal cover (4).
2. Disconnect the WHI/ORN wire of the harness from the thermal overload protector.
3. Disconnect the BLK wire from the Compressor's upper terminal.
4. Remove overload protector retainer (3) and thermal overload protector (2) as an assembly.
5. Remove retainer (3) from overload protector (2) and discard overload protector.

6. Install retainer (3) on new overload protector (2).
7. Install retainer (3) and overload protector (2) on the compressor terminal bracket.
8. Refer to Fig. 22 and reconnect the thermal overload protector wires.
9. Reinstall terminal cover (4) and cover retainer (5).



##### Compressor Run Capacitor: Refer to FIG. 20

1. Disconnect the run capacitor leads.
2. Remove the nut securing the run capacitor to the capacitor mounting bracket.
3. Remove run capacitor and discard.
4. Place new run capacitor on capacitor mounting bracket and secure nut.
5. Refer to Fig. 23 and reconnect the wires.

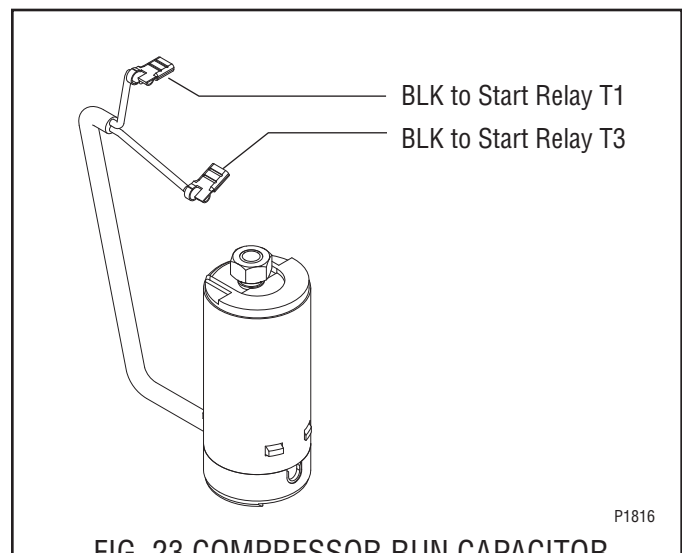

## SERVICE (continued)

### COMPRESSOR (EMBRACO) (cont.)

#### Removal and Replacement:

#### Compressor Assy:

**NOTE:** Before removal of any refrigeration component the refrigerant in the system must be reclaimed by a licensed refrigeration repair person.

**NOTE:** When replacing the compressor it is recommended that the dryer also be replaced.

1. Disconnect the tubes from the condenser and the accumulator.
2. Disconnect the compressor wiring harness from the dispenser main wiring harness.
3. Remove the four .25-20 keps nuts and washers securing the compressor to the chassis. Set nuts and washers aside for reassembly.
4. Disconnect and remove the transformer.
5. From the right side of the dispenser lift the compressor assembly over the four studs in the chassis and remove compressor.
6. Install new compressor over the four studs in the dispenser chassis with the fill valve to the left side of the dispenser.
7. Secure compressor to the dispenser chassis using four .25-20 keps nuts and washers.
8. Reconnect tubes from the condenser and the accumulator to the compressor.
9. Reinstall transformer.
10. Evacuate the system.
11. Recharge 120V system with 10 oz. of Type 404A refrigerant. Design Pressures: High 430 - Low 80  
Recharge 230V system with 9.5 oz. of Type 404A refrigerant. Design Pressures: High 215 - Low 40

**NOTE:** The charging of the system must be done by a licensed refrigeration repair person.

**NOTE:** Refer to Wiring Diagrams when reconnecting wires to Compressor, Thermal Overload Protector, Start Relay, and Run Capacitor.



## SERVICE (continued)

### COMPRESSOR (EMBRACO) (cont.)

#### Important Safeguards:

- Trained service personnel with the knowledge of servicing and troubleshooting refrigeration systems or related components should be used.
- Always be alert of smell and sounds (arching, popping and humming) coming from the compressor. Disconnect power or unplug immediately and get away.
- Always ensure main power is disconnected before any removal of a protective cover.
- Compressor oil and refrigerant being vented can create a hazardous condition of chemical burn, frostbite or fire.
- Never reset a breaker or replace a blown fuse without checking the compressor or related components for a short circuit or ground fault condition first.
- Always wear and use the appropriate safety gear when servicing a refrigeration system. Protective gloves, eyewear, shoes, clothes and tools.
- If compressor ground fault condition exists, keep power off, disconnect power leads, mark or tag compressor to indicate ground fault or defective compressor before replacing with a new compressor.

#### Compressor Wiring Diagram:

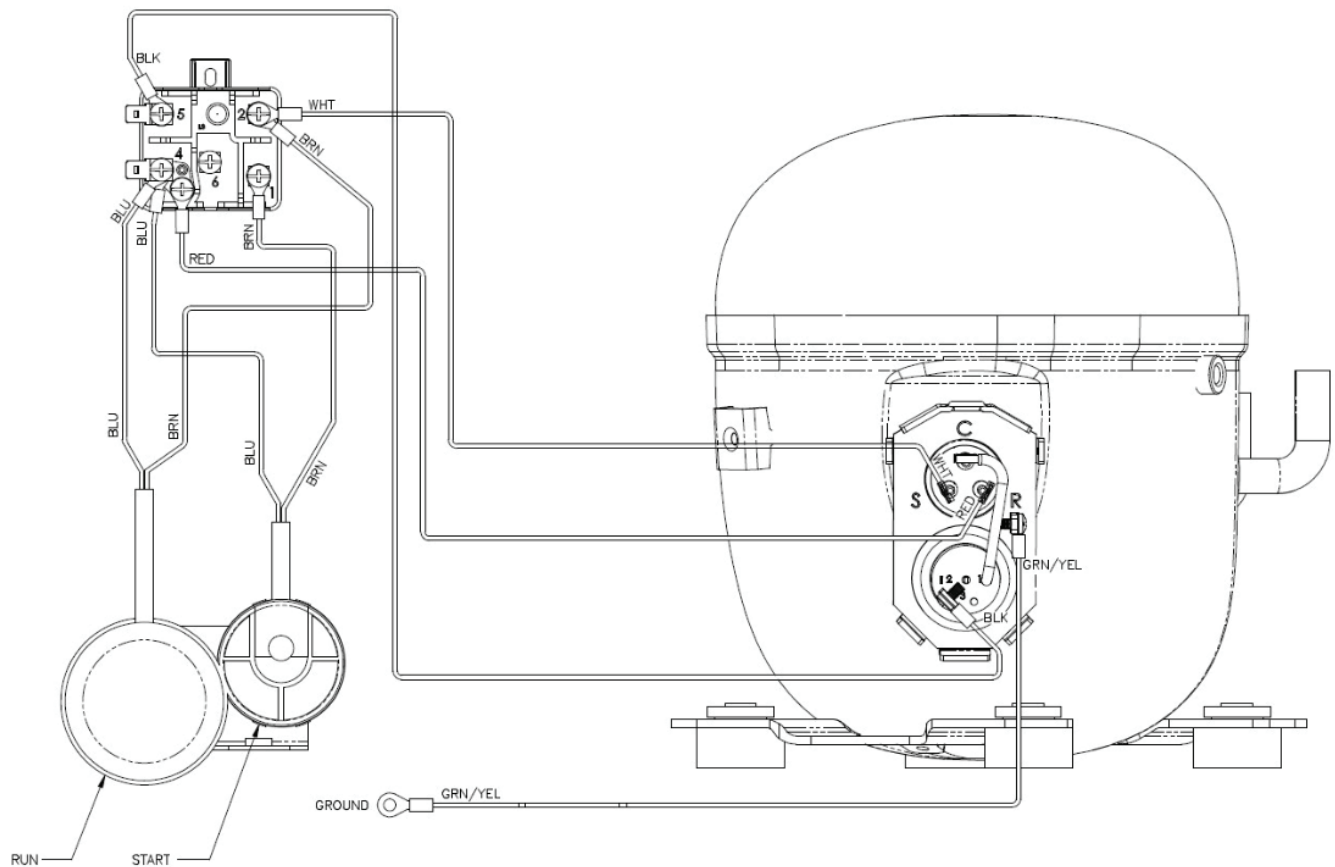

## COMPRESSOR (EMBRACO)

### Compressor Windings & Related Component Testing:

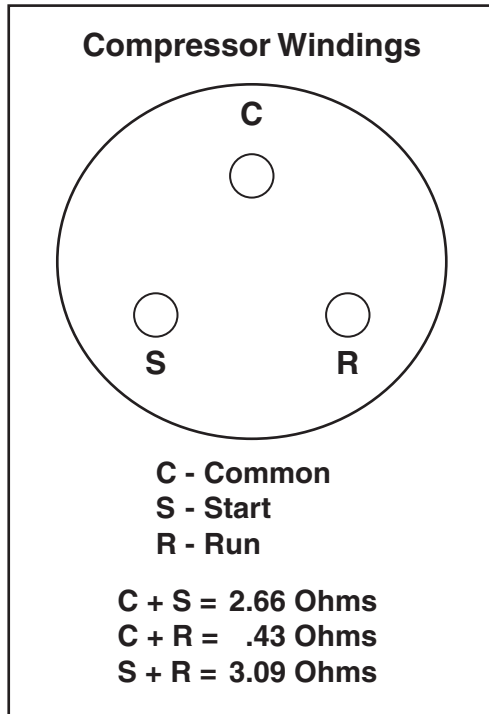

Note: Measure the resistance (ohms) between terminal pins C&S and C&R around ambient temperature of 77° F. Add the resistance between C & S and C & R. The sum should equal the resistance found between S & R. A 10% deviation is acceptable.

Continuity must be present between C & S and C & R. If there is no continuity on start or run winding, there is an interruption within that winding.

Check the C (common) compressor winding to compressor ground terminal/housing. If continuity is present, one of the compressor windings is shorted to ground.

#### Check Compressor Windings for Ground Fault:

Upon removal of the protective terminal cover, if evidence is shown by any lead or terminal being overheated, it is a good indication that a compressor winding problem may exist. Follow the recommended step below to check the compressor winding insulation. If a ground fault is detected with the compressor, keep the power off, thermal protector and potential relay disconnected. A licensed certified refrigerant technician will need to replace a defective compressor.

#### Testing Compressor Windings/Insulation with a Megger:

A megger is a preferred test over using a typical ohm meter for testing the compressor windings. The megger checks the insulation factor of a winding making sure it is actually insulated and not leaking current (Ground Fault). An ohm meter usually produce a low voltage for reading resistance verses a megger uses higher direct voltage source to measure insulation resistance to detect a breakdown in the motor winding insulation.

**Step 1:** Disconnect all electrical power to the BUNN ULTRA-2 HP.

**Step 2:** Access compressor terminal pins and disconnect the wire leads going to the compressor pins.

**Step 3:** Set the megger to the compressor applicable voltage rating. If the megger you are using only has a few specific voltage ranges, select the next highest voltage above your compressor volt range.

**Step 4:** Connect one lead of the megger to the copper suction line or housing. Connect the other lead to one of the compressor terminal pins (winding).

**Step 5:** Repeat the procedure for the two remaining terminal pins. If the instrument indicates any resistance less than 2 megohms between any pin and the housing (copper suction line), a ground fault exists. Replace compressor.

## SERVICE (continued)

### COMPRESSOR (EMBRACO)

#### External Thermal Protector

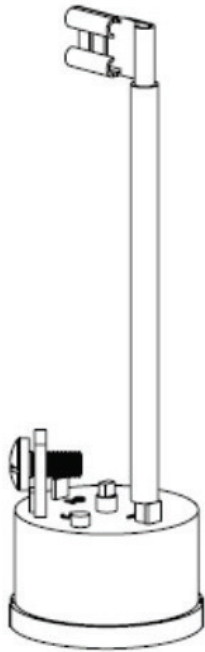

Check for continuity across the thermal protector terminals. Before testing the external thermal protector, ensure the thermal protector had enough time to cool off and reset. If no continuity is present across the terminals, replace the thermal protector.

#### Potential Start Relay Mounting Position

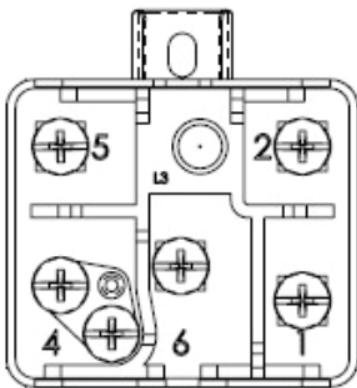

Always check the relay for correct mounting position before continuing with the following continuity check.

- Relay terminal 2 and 5: No continuity, broken coil, replace relay.
- Relay terminal 1 and 2: No continuity, contacts are open, replace relay.

#### Start Capacitor

Start Capacitor: BUNN P/N# [39804.0004](#)

Rating: 243-292 MFD 165V 50/60HZ

- Disconnect the start capacitor from the system.
- Remove the bleed resistor.
- Use a capacitance meter to measure the capacitance. The capacitance value should be the rated value minus 0% to plus 20%. If it is outside of this range, then the start capacitor needs to be replaced.

#### Run Capacitor

Run Capacitor: BUNN P/N# [44820.0004](#)

Run Capacitor: 35 +/-5% MFD 425V 50/60HZ

**NOTE:** Use a 20,000 ohm resistor set-up to discharge the capacitor before removing from the machine. By doing this, will avoid possible damage to the capacitor, measuring device and risk of electrical shock.

Once the capacitor is properly discharged, use a capacitance meter to check the capacitance value. The value should be within 5% range of the marked capacitor value.

## SERVICE (continued)

### RELAY (or CONTACTOR on Early Models)

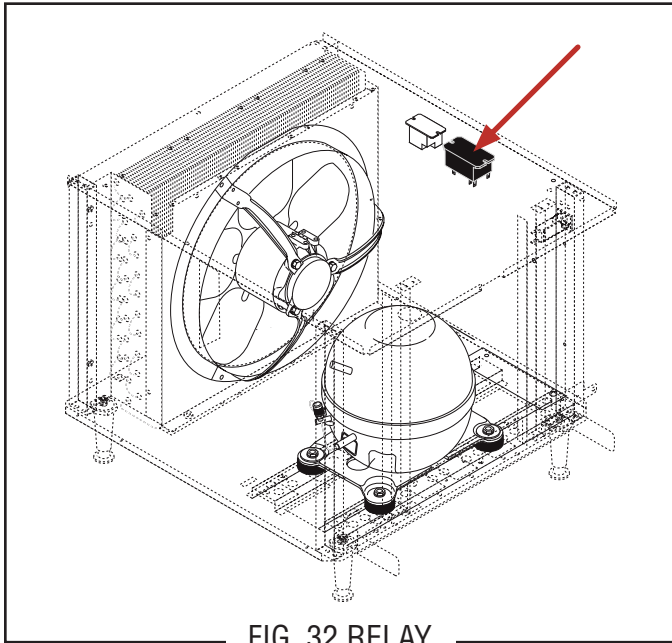

FIG. 32 RELAY

#### Location:

The relay (or contactor) is located inside the dispenser chassis on the lower outside of the component bracket.

#### Test Procedures:

1. Disconnect the dispenser from the power source.
2. Remove the right side panel.
3. Connect the dispenser to the power source.
4. Turn on power (I/O) switch. Verify UPPER case "ICE" or "CHILL" mode.
5. With a voltmeter, check the voltage across the white wire and the orange wire. The indication must be:
  - a) 120 volts ac for 120 volt models.
  - b) 230 volts ac for 230 volt models.
6. Disconnect the dispenser from the power source.

If voltage is present as described, proceed to #7.

If voltage is not present as described, refer to the *Wiring Diagram* and check the dispenser wiring harness. If harness has continuity, replace Control Board.

7. Disconnect the black wire and the WHI/ORN wires from relay terminals #6 and #8.
8. Connect the dispenser to the power source.
9. Turn on power (I/O) switch. Verify UPPER case "ICE" or "CHILL" and check for continuity across terminals on relay.

If continuity is present as described, disconnect the dispenser from power source and reconnect wires to terminals #6 and #8, the relay is working.

If continuity is not present as described, do the same continuity test across terminals #2 and #4. If continuity is present between terminals #2 and #4, reconnect wires to terminals #2 and #4 instead of #6 and #8. If continuity is not present as described, replace the relay.

#### Removal and Replacement:

1. Disconnect the wires from the relay.
2. Remove the two #8-32 locking screws securing the relay to the chassis. Remove and discard relay.
3. Install the new relay on the chassis using two #8-32 locking screws.
4. Refer to Fig. 33 and 34 to reconnect the wires.

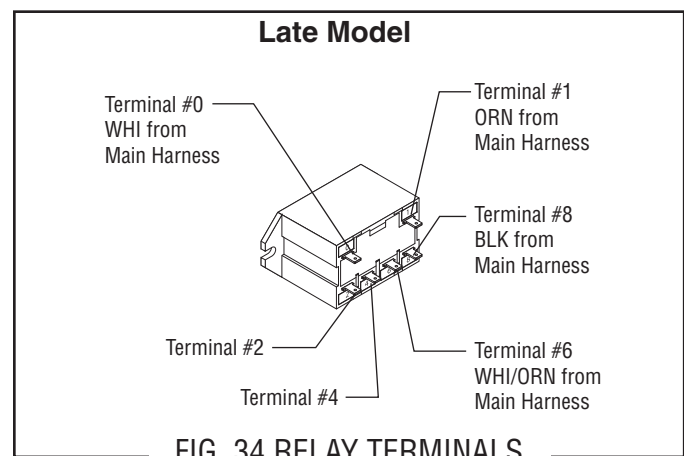
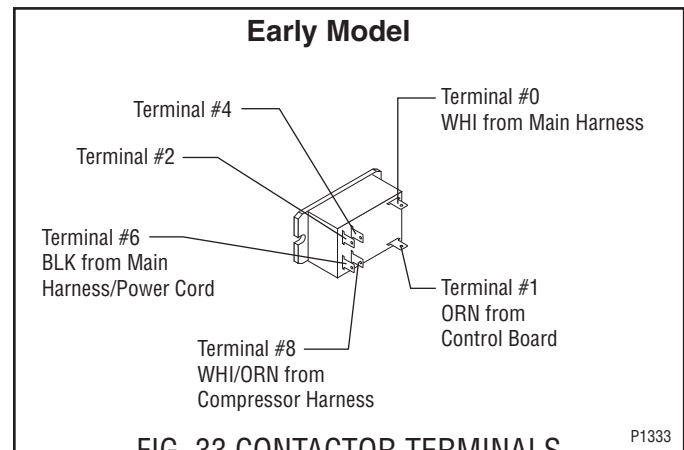

## SERVICE (continued)

### CONTROL BOARD

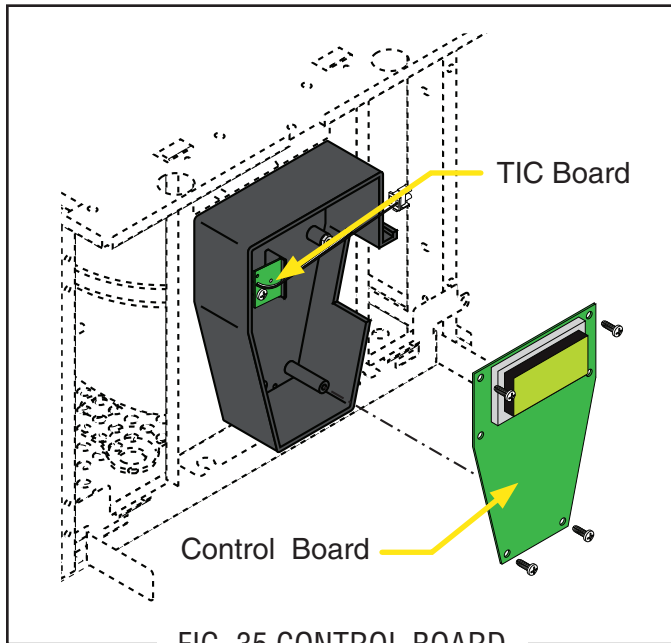

#### Removal and Replacement:

1. Disconnect the main harness from connector J5 on the control board.
2. Remove the four #8-18 pan head screws securing the control board to the mounting box. Disconnect TIC (memory) board from connector J1 on the control board.

**NOTE:** On models with Auto-Fill, remove the auto-fill adapter board.

3. Reconnect TIC board to J1 on the new control board.
4. Secure the control board to mounting box with the four #8-18 pan head screws.
5. Reconnect the main harness to J5 on the control board.

#### Location:

The control board is located behind the front panel, on the front of the chassis.

#### Test Procedures:

1. Disconnect the dispenser from the power source.
2. Remove the left and right side panels. Remove the front panel and unplug ribbon cable from J5.
3. With a voltmeter, check the supply voltage from J5-8 (WHI/BLU) to J5-20 (WHI/BLK).
4. Connect the dispenser to the power source.

The indication must be:

Approximately 12.6 volts ac for all models.

5. Disconnect the dispenser from the power source.

If voltage is present as described and the dispenser does not operate, replace Control Board.

If voltage is not present as described, refer to the *Wiring Diagram* and check the dispenser wiring harness.

COOLING DRUM ALIGNMENT

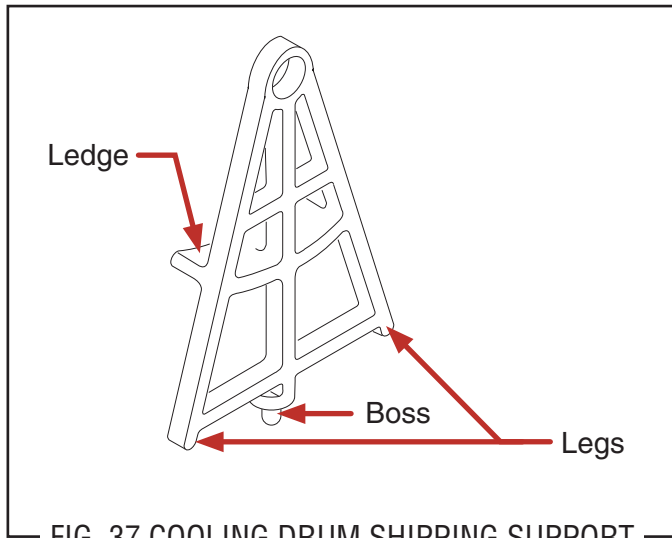

FIG. 37 COOLING DRUM SHIPPING SUPPORT

The "A" shaped Cooling Drum Shipping Supports, removed during *Initial Setup* should be kept and used as a tool to reset the alignment of the cooling drums should it ever be required.

Symptoms:

Squeaky Operation, hopper lifts or won't seat properly, hopper is pushed to one side or the other.

To check alignment

1. Place the "A" shaped support on the auger shaft with the ledge under the cooling drum.
2. Lift the cooling drum while rotating the support into a vertical position. The boss on the very bottom will drop into the hopper drip tray's drain hole.

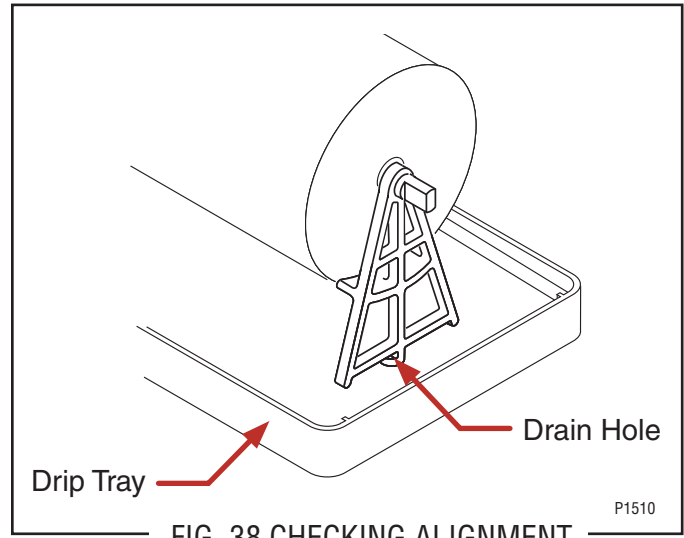

FIG. 38 CHECKING ALIGNMENT

P1510

When in its proper position, the cooling drum will cause a slight pressure on the hopper drip tray drain hole and the two legs will be equidistant from the hopper drip tray.

If adjustment is needed, remove the support and gently force the free end of the evaporator in the direction the adjustment is needed.

Reinstall the support, check the alignment, and readjust the cooling drums as required.

**Never try to remove the cooling drums (4 screws) unless trained refrigeration technician is replacing the evaporator assembly.**

FAN

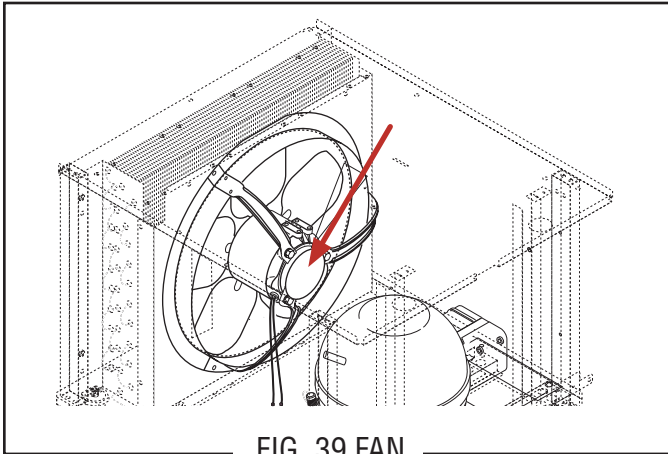

FIG. 39 FAN

Location:

The fan is located inside the dispenser chassis just in front of the condenser.

Test Procedures:

1. Disconnect the dispenser from the power source.
2. Disconnect the gray and white wires from the main harness to the fan leads.
3. With a voltmeter, check the voltage across the gray and the white wires. Connect the dispenser to the power source. In the "ICE" or "CHILL" mode; The indication must be:
  - a) 120 volts ac for 120 volt models.
  - b) 230 volts ac for 230 volt models.
4. Disconnect the dispenser from the power source. If voltage is present as described, replace the fan. If voltage is not present as described, refer to *Wiring Diagram* and check the dispenser wiring harness.

Removal and Replacement (Refer to Fig. 40)

**NOTE:** Leave the hopper in place. This keeps it in alignment while the condenser shroud is removed.

1. Disconnect the fan leads from the wiring harness.
2. Remove the four #6 crimp-tite screws securing the condenser shroud and fan assy (1) to the condenser and the two #8-32 locking screws securing the condenser shroud and fan assy (1) to the chassis base.
3. Remove the condenser shroud and fan assy from the right side of the dispenser.
4. Remove the three #6 thread cutting screws securing the fan assy to condenser shroud (7). Set condenser shroud and screws aside for reassembly.
5. Remove the three #8-32 thread forming screws securing motor (5) to condenser fan shroud/mount (6). Set shroud and screws aside for reassembly.
6. Remove speed nut (2) from the motor shaft.
7. Remove fan (3).

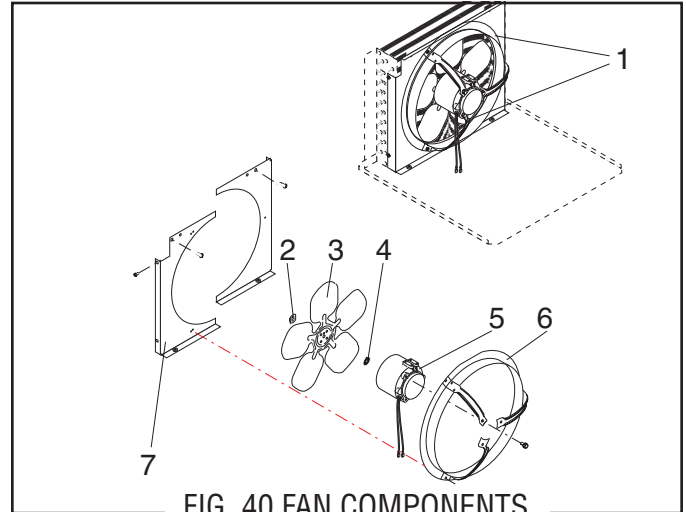

FIG. 40 FAN COMPONENTS

8. Remove silencer (4).
 

1. Condenser Shroud and Fan Assy	3. Fan Blade
2. Speed Nut	5. Motor
4. Silencer	6. Shroud/Mount
7. Condenser Shroud	
9. Install silencer (4) on new motor assy.
10. Install fan (3) on new motor assy.
11. Install speed nut (2) on new motor assy.
12. Using three #8-32 thread forming screws secure new motor assy to shroud/mount (6).
13. Using three #6-32 thread cutting screws secure new motor and shroud/mount to the condenser shroud (7).
14. Using two #8-32 locking screws secure condenser shroud and fan assy (1) to the chassis base.
15. Using four #8-32 crimp-tite screws secure the condenser shroud and fan assembly (1) to the condenser.
16. Refer to Fig. 41 and reconnect the leads on the new motor to the dispenser wiring harness.
17. Use cable ties to secure wires away from fan blades.

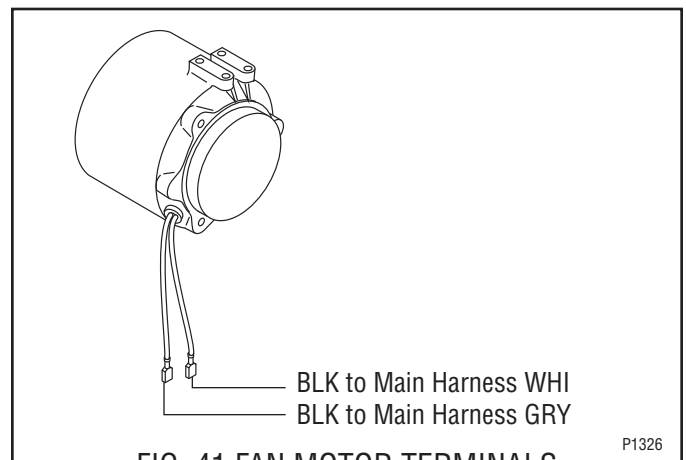

FIG. 41 FAN MOTOR TERMINALS

P1326

## HOT GAS TEMPERATURE SENSOR

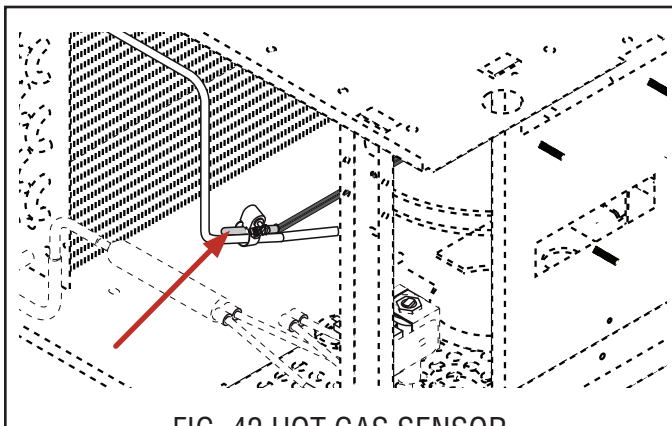

FIG. 42 HOT GAS SENSOR

### Location:

The Hot Gas Sensor is located on the Condenser-to-Compressor tube on the left side of the housing.

### Test Procedures:

1. Remove the left side housing panel.
2. Connect a voltmeter, across the two leads of the hot gas sensor (leave plug connected);  
The indication must be:
  - a) Approx. 4.0 vdc @ 37° F
  - b) Approx. 3.4 vdc @ 82° F

If voltage reading is 0v, the Control Board is not supplying the necessart 5v and should be replaced. If the reading stays at 5vdc, replace the hot gas sensor.

### Alternate Test:

2. Disconnect the plug on the hot gas sensor leads from the connector on the main harness.
3. Connect an ohmmeter across the two leads of the hot gas sensor;  
The indication must be:
  - a) 678 ohms @ 212° F  $\pm$  10%
  - b) 10k ohms @ 77° F  $\pm$  10%

If resistance reading is not within the range listed above, replace sensor.

### Removal and Replacement (Refer to Fig. 42)

1. Remove the left side housing panel.
2. Disconnect the plug on the hot gas sensor leads from the connector on the main harness.
3. Remove the clamp securing the hot gas sensor to Condenser-to-Compressor tube.
4. Securing the new hot gas sensor to Condenser-to-Compressor tube using the clampp previously removed.
5. Refer to Fig. 43 and plug the new sensor into the connector on the main harness.

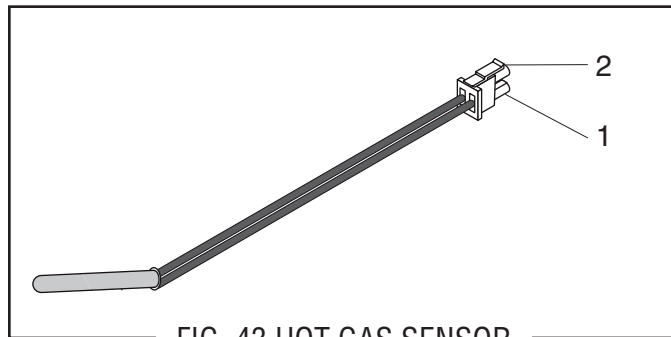

FIG. 43 HOT GAS SENSOR

- 1 – WHI to YEL J5-10 (Control Board) Positive
- 2 – WHI to WHI/BLK Main Harness /J5-9 (Control Board) Negative

## LAMP CORD ASSEMBLY

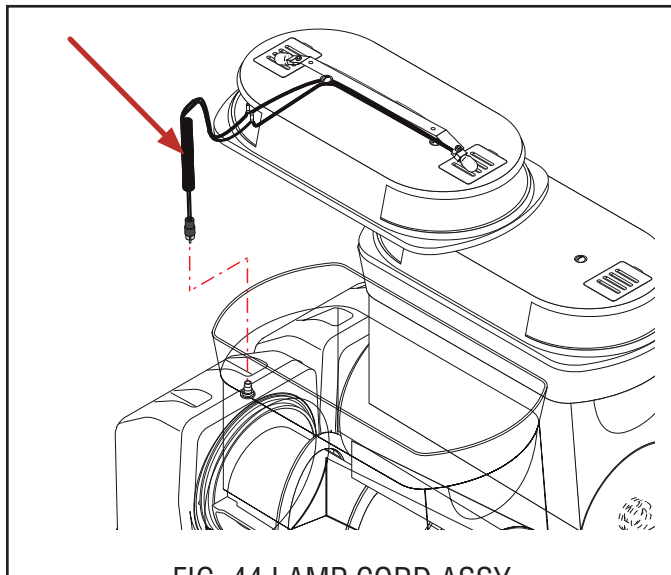

FIG. 44 LAMP CORD ASSY

### Location:

The lamp cord assembly is located in the top center of the auger motor cover.

### Test Procedures:

1. Disconnect the dispenser from the power source.
2. Unplug the lamp cord assembly from lamp cord connector assembly.
3. Check for continuity across the tip of the cord assembly and the housing. Continuity must not be present when both lamps are removed.

If continuity is present as described, the cord assembly is operating properly.

If continuity is not present as described, replace the cord assembly.

### Removal and Replacement:

1. Disconnect the lamp cord assembly from the lamp cord connector assembly in the top of the auger motor cover.
2. Remove the hopper cover with the lamp cord assembly from the hopper.
3. Remove hopper cover liner from the hopper cover.
4. Cut the closed splice terminals connecting lamp cord assembly to the lamp holder/socket assembly off.

5. Remove lamp cord assembly from hopper cover and discard.
6. Push new lamp cord wires through the holes on the left outside top of the hopper cover.
7. Strip the wires from the lamp holder/socket assembly approximately .375".
8. Using the two wire nuts, supplied, connect the new lamp cord assembly to the lamp holder/socket assembly wires.
9. Reinstall the hopper liner to the bottom of the hopper cover.
10. Reinstall the hopper cover to the hopper.
11. Plug in the new lamp cord assembly to the lamp cord connector assembly on top of the auger motor cover.
12. Refer to Fig. 45 when reconnecting the wires.

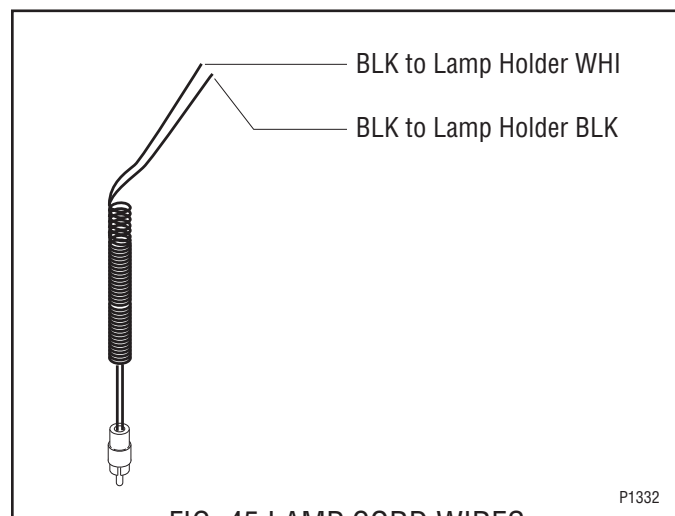

FIG. 45 LAMP CORD WIRES

P1332

**LAMP CORD CONNECTOR**

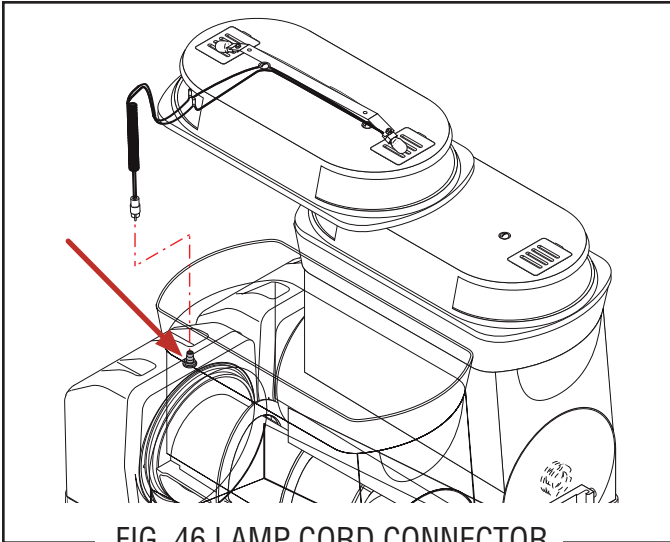

FIG. 46 LAMP CORD CONNECTOR

Location:

The lamp cord connectors are located inside the center top of the auger motor covers.

Test Procedures:

1. Disconnect the dispenser from the power source.
2. Disconnect the plug on the dispenser main harness from the connector from the lamp cord connector.
3. Connect the dispenser to the power source. Turn on power (I/O) switch. The indication must be approximately 12.6 volts dc.
4. Disconnect the dispenser from the power source.

If voltage is present as described, proceed to #5.

If voltage is not present as described, refer to the *Wiring Diagram* and check the dispenser main wiring harness.

**NOTE:** Lamp cord assembly (Fig. 46) and lamps, must be tested and determined to be functioning properly before proceeding to step 5.

5. Check for continuity across the black wire pin and red wire pin of the lamp cord connector (Fig. 47). Continuity must be present when the lamp cord assembly is connected and must not be present when lamp cord assembly is disconnected from lamp cord connector.

If continuity is not present when lamp cord assembly is connected or continuity is present when lamp cord assembly is not connected, replace the lamp cord connector.

Removal and Replacement:

1. Disconnect the lamp cord assembly from the lamp cord connector.
2. Remove the two #8-32 locking screws securing the auger motor cover the auger motor bracket/cooling drum bracket. Move cover back far enough to gain access to the lamp cord connector.
3. Disconnect the lamp cord connector wires from the dispenser main wiring harness.
4. Remove nut and washer securing the lamp cord connector to the auger motor cover and discard nut, washer and lamp cord connector.
5. Remove new nut and washer from new lamp cord connector.
6. Push new lamp cord connector through the hole in the auger motor cover and secure with the new nut and washer.
7. Reconnect the wires on the cord connector to the dispenser main wiring harness.
8. Position auger motor cover on auger motor bracket/cooling drum bracket and secure with two #8-32 locking screws.
9. Refer to Fig. 47 when reconnecting wires.

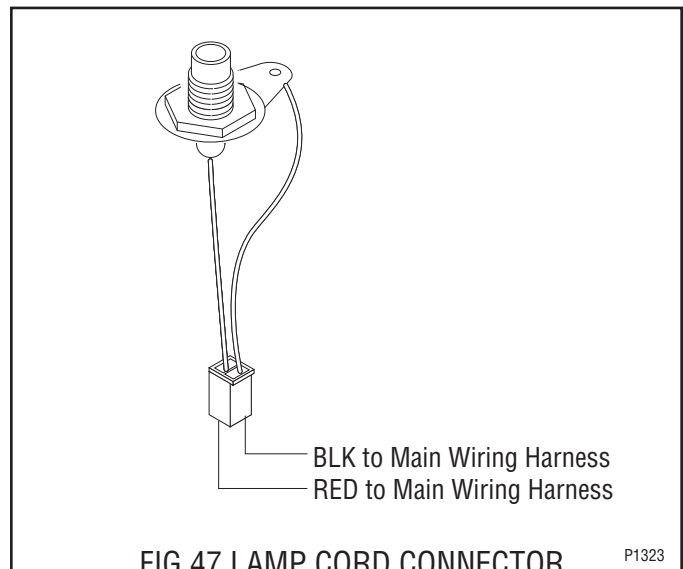

FIG.47 LAMP CORD CONNECTOR

P1323

## LAMP HOLDER/SOCKET ASSEMBLY

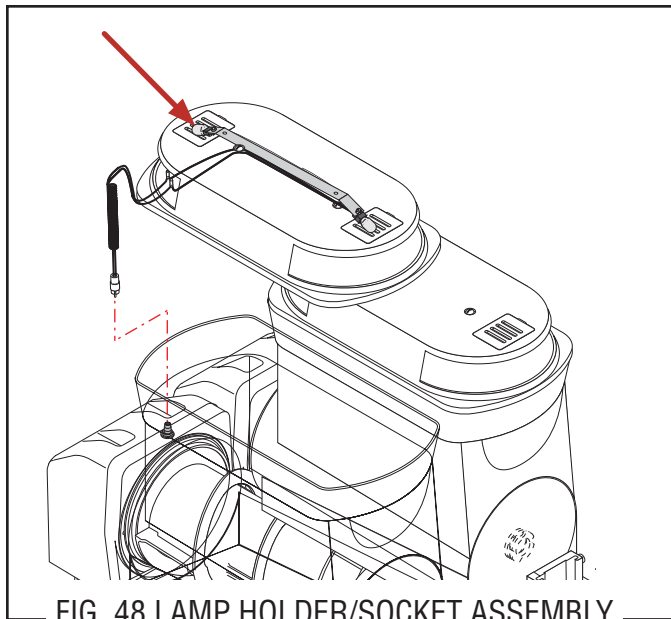

FIG. 48 LAMP HOLDER/SOCKET ASSEMBLY

### Location:

The lamp holder/socket assemblies are located inside the hopper covers.

### Test Procedures:

1. Disconnect the lamp cord assembly from the lamp cord connector.
2. Remove the lamps from the lamp holder/socket assembly.
3. With a voltmeter, check the voltage across the pin sockets in the plugs in the "DAY" mode. Reconnect the lamp cord to the lamp cord connector. The indication must be approximately 12.6 volts dc.
4. Disconnect the lamp cord from the lamp cord connector.

If voltage is present as described, the lamp holder/socket assembly is operating properly.

If voltage is not present as described, replace the lamp holder/socket assembly.

5. Check for continuity across the terminals on the lamps.

If continuity is present as described, the lamps are operating properly.

If continuity is not present as described, replace the lamp.

### Removal and Replacement:

1. Disconnect the lamp cord assembly from the lamp cord connector assembly in the top of the auger motor cover.
2. Remove the hopper cover with the lamp cord assembly from the hopper.
3. Remove hopper cover liner from the hopper cover.
4. Cut off the closed-end splices connecting lamp cord assembly to the lamp holder/socket assembly.
5. Remove the two lamps.
6. Remove the two #2-56 screws and elastic lock nuts securing the lamp holder/socket assembly to the mounting bracket. Remove lamp holder/socket assembly and discard.
7. Install new lamp holder/socket assembly on mounting bracket using two #2-56 screws and elastic lock nuts.
8. Reinstall lamps.
9. Strip the wires from the lamp cord assembly approximately .38".
10. Using the two wire nuts, supplied, connect the lamp cord assembly to the new lamp holder/socket assembly wires.
11. Reinstall the hopper liner to the bottom of the hopper cover.
12. Reinstall the hopper cover to the hopper.
13. Plug in the lamp cord assembly to the lamp cord connector assembly on left top of the auger motor cover.
14. Refer to Fig. 49 when reconnecting the wires.

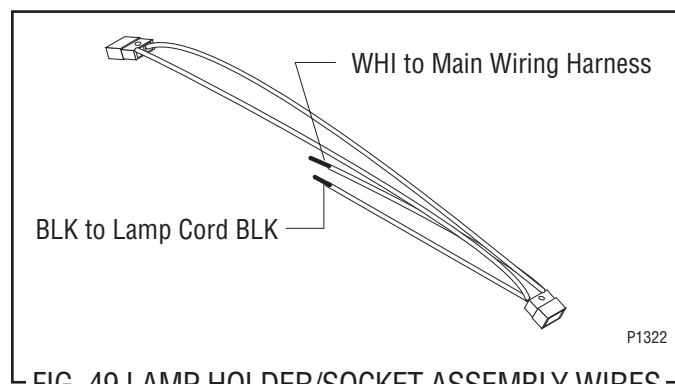

FIG. 49 LAMP HOLDER/SOCKET ASSEMBLY WIRES

**LED Lamps**

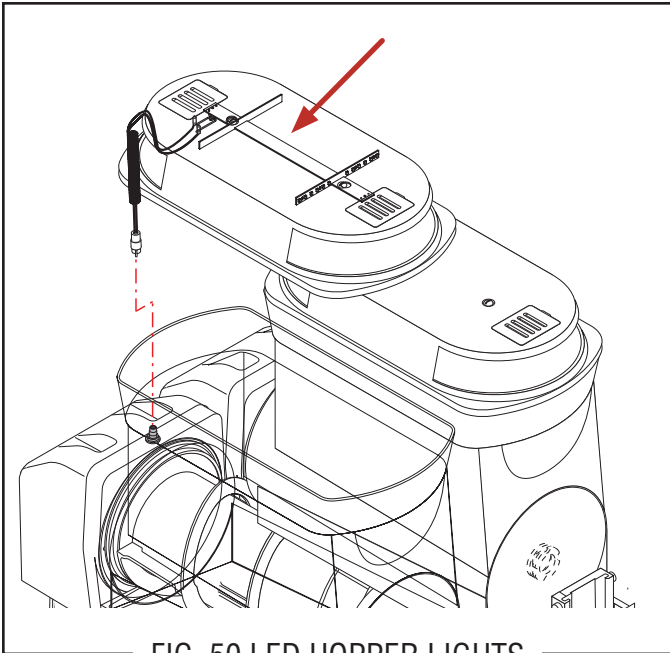

FIG. 50 LED HOPPER LIGHTS

Removal and Replacement:

1. Disconnect power from the dispenser.
2. Disconnect the lamp cord assembly from the lamp cord connector assembly in the top of the auger motor cover.
3. Remove the hopper cover with the lamp cord assembly from the hopper.
4. Remove hopper cover liner from the hopper cover.
5. Remove the two #2-28 screws securing the LED circuit board assembly to the cover liner.
6. Replace the LED circuit board assembly.

Location:

The LED hopper lights are located inside the hopper lid.

Test Procedures:

1. Disconnect power from the dispenser.
2. Disconnect the black and red leads from the LEDs.
3. Check the voltage across the two leads with a voltmeter. Reconnect power to the dispenser. The indication must be approximately 12 volts ac.
4. Disconnect power from the dispenser.

If voltage is present as described, the LED board is faulty.

If voltage is not present as described, retrace the wiring circuit to find the fault.

5. Check for continuity across the terminals on the leads and the LED harness.

If continuity is present as described, the lamp is operating properly.

If continuity is not present as described, replace the lamp.

## SERVICE (continued)

### LAMP RELAY

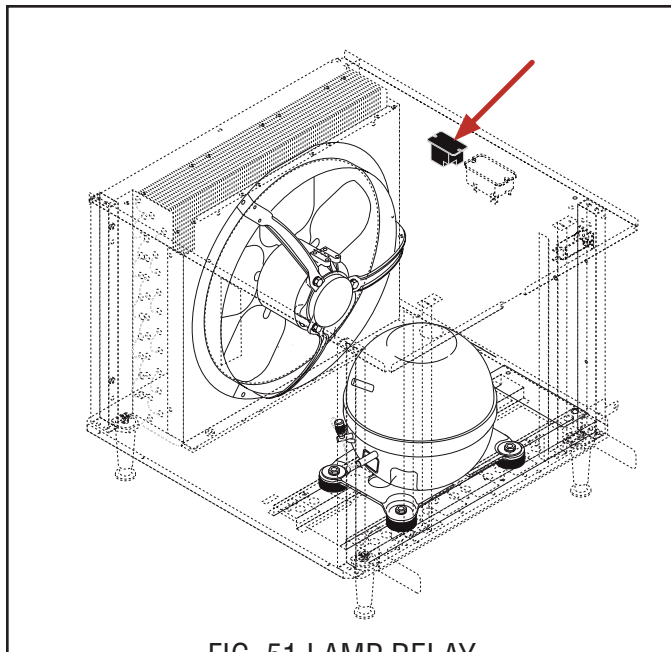

FIG. 51 LAMP RELAY

#### Location:

The Lamp Relay is located under the upper deck of the chassis, on the right side.

#### Test Procedures: (Coil)

1. Disconnect the dispenser from the power source.
2. Connect a voltmeter, across BLU/BLK wire (+) and the VIO wire (-).
3. Connect the dispenser from the power source.
4. Turn on Power (I/O) Switch. Verify the dispenser is in the "DAY" mode.

The indication must be:

- a) 12 volts dc in the "DAY" mode,
- b) 0 volts dc in the "NIGHT" mode.

If voltage is present as described, the Control Board is operating properly. Replace Relay if it does not energize when voltage is present.

If voltage is not present as described, refer to the Wiring Diagrams and check the main wiring harness.

If harness has continuity, replace the Control Board.

#### Test Procedures: (Contacts)

1. Disconnect the dispenser from the power source.
2. Disconnect the WHI/VIO and WHI/YEL wires. Connect an ohmmeter across the two coil terminals where the wires were just removed.
3. Connect the dispenser from the power source.
4. Turn on Power (I/O) Switch. Verify the dispenser is in the "DAY" mode.

The indication must be:

- a) continuity in the "DAY" mode,
- b) open in the "NIGHT" mode.

If continuity is present as described, the Relay is operating properly.

If continuity is not present as described, replace the Relay.

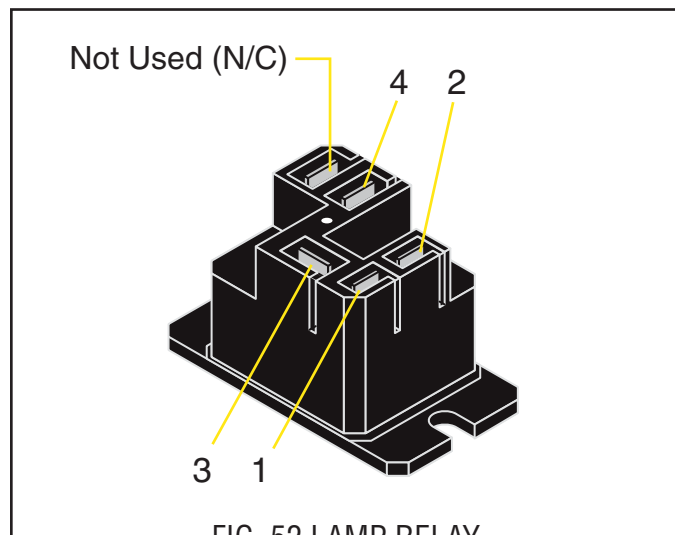

FIG. 52 LAMP RELAY

1. (-) 12vdc (VIO) from Control Board J5-7
2. (+) 12vdc (BLU/BLK) to Control Board J5-19
3. 12vac (WHI/VIO) to Lamp Connectors
4. 12vac (WHI/YEL) from Circuit Breaker

MEMBRANE SWITCH

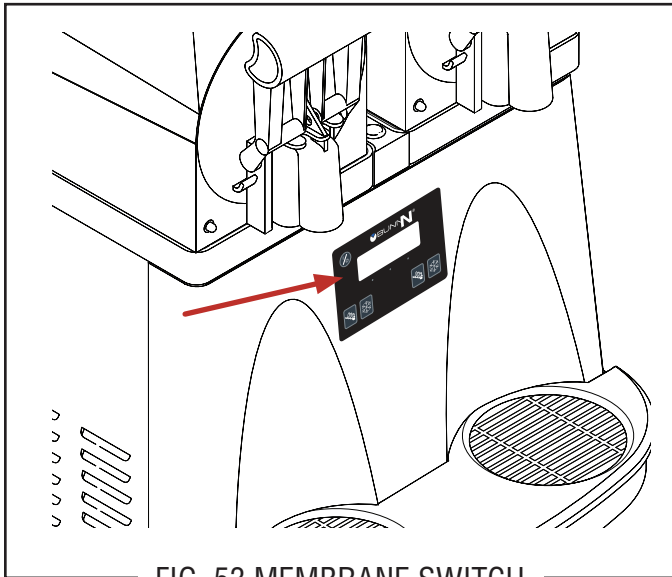

FIG. 53 MEMBRANE SWITCH

Location:

The membrane switch is located on the front panel.

Test Procedures:

**NOTE:** Before continuing, check that the ribbon cable is properly connected to the control board and not a pin off in either direction.

1. Disconnect the dispenser from the power source.
2. Remove the right and left side panels.
3. Remove the front panel and disconnect ribbon cable.
4. Check for continuity of the switches using pin #7 as common.

#7 - #1 (shield) no continuity

#7 - #2 (Left Auger)

#7 - #3 (I/O)

#7 - #4 (not used)

#7 - #5 (Left ICE/CHILL/OFF)

#7 - #6 (ULTRA)

#7 - #8 (GOURMET)

#7 - #9 (not used)

#7 - #10 (ICE)

#7 - #11 (Right Auger)

#7 - #12 (Right ICE/CHILL/OFF)

If continuity is not present when the appropriate switch is pressed, the Membrane Switch must be replaced.

If continuity is present, check the short harness going to J2 on the Control Board.

Removal and Replacement:

1. Disconnect the dispenser from the power source.
2. Remove right and left side panels.
3. Remove front panel and disconnect ribbon cable.
4. Peel the old Membrane Switch off the front panel and discard. Clean any remaining adhesive from front panel with mineral spirits and then alcohol.
5. Remove protective paper backing from back side of new Membrane Switch.
6. Guide ribbon cable through narrow slot in panel. Carefully position new Membrane Switch on panel, while centering display window to opening.
7. Refer to Fig. 54 and connect the ribbon cable to the short harness from the Control Board.

**NOTE:** The black wire should correspond to the #1 printed on the clear portion of the cable.

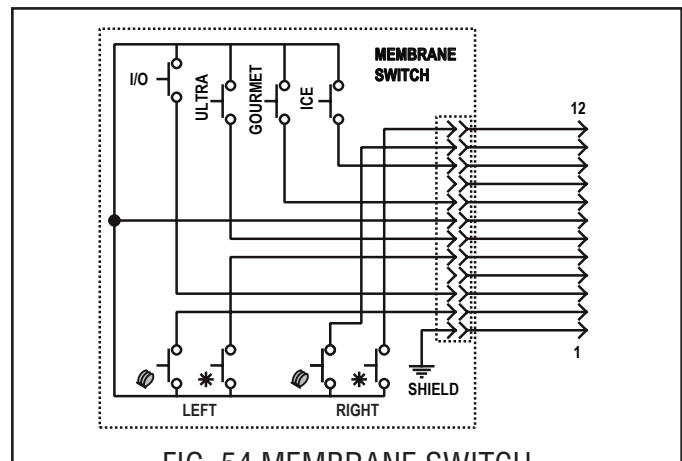

FIG. 54 MEMBRANE SWITCH

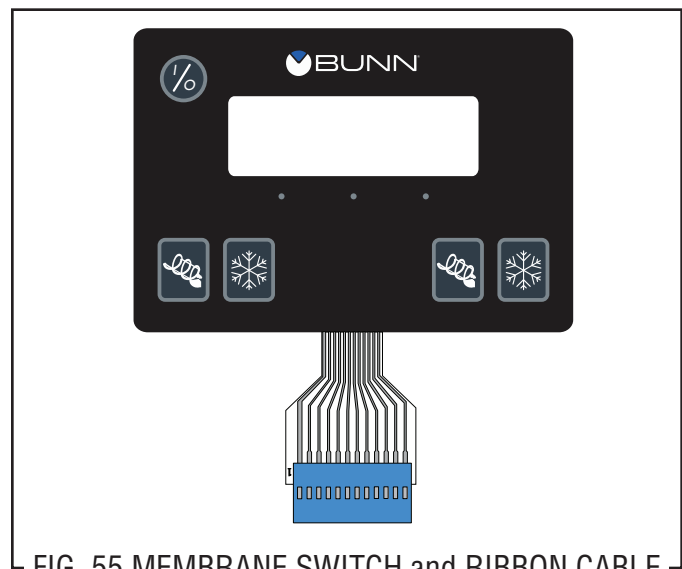

FIG. 55 MEMBRANE SWITCH and RIBBON CABLE

**SOLENOIDS**

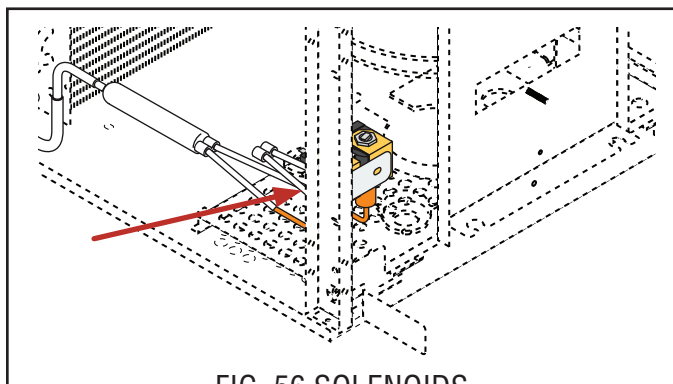

FIG. 56 SOLENOIDS

Location:

The solenoids are mounted on a bracket that is attached to the front left corner of the chassis.

Test Procedures:

1. Disconnect the dispenser from the power source.
2. Remove the left side panel.
3. Connect a voltmeter across the white wire and the other wire on the solenoid to be tested (output from Control Board must be checked with load connected).
4. Connect the dispenser to the power source.
5. Turn on the power (I/O) switch.
6. Verify that the side being tested is in the UPPER case "ICE" or "CHILL" mode.

The indication must be:

- a) 120 volts ac for 120 volt models.
- b) 230 volts ac for 230 volt models.

7. Disconnect the dispenser from the power source.

If voltage is present as described, proceed to #8

If voltage is not present as described, refer to the Wiring Diagram and check the main wiring harness.

8. Disconnect both wires and check for continuity across the solenoid valve coil (Approximately 350 ohms).

If continuity is present as described, reconnect the wires to the solenoid.

If continuity is not present as described, replace the solenoids.

9. Repeat steps 4-6. If the cooling drum fails to buildup a layer of frost, there may be a blockage in the refrigerant line or solenoid. This will require a licensed refrigeration repair person to evacuate the system and make repairs as necessary.

**NOTE:** Before removal of any refrigeration component the refrigerant in the system must be reclaimed by a licensed refrigeration repair person.

Removal and Replacement:

1. Disconnect the wires from both solenoids.
2. Disconnect the refrigerant lines from the solenoids to the cooling drums and the refrigerant line from the filter/drier/splitter assembly.
3. Remove the #8-32 locking screw securing solenoid bracket to the dispenser chassis.
4. Remove bracket and solenoids from the chassis assembly.
5. Remove the two #6 crimpite screws securing the solenoids to the bracket.
6. Remove solenoid and clean or discard.
7. Install new solenoids on mounting bracket using two #6 crimpite screws.
8. Reinstall mounting bracket and solenoids inside the dispenser chassis, securing with a #8-32locking screw.
9. Reconnect the tubes from the accumulator and the cooling drums.
10. Refer to Fig. 57 and reconnect the wires.
11. Evacuate the system.
12. Recharge the system with the appropriate coolant and to the pressures directed on the decals.

**NOTE:** The charging of the system must be done by a licensed refrigeration repair person.

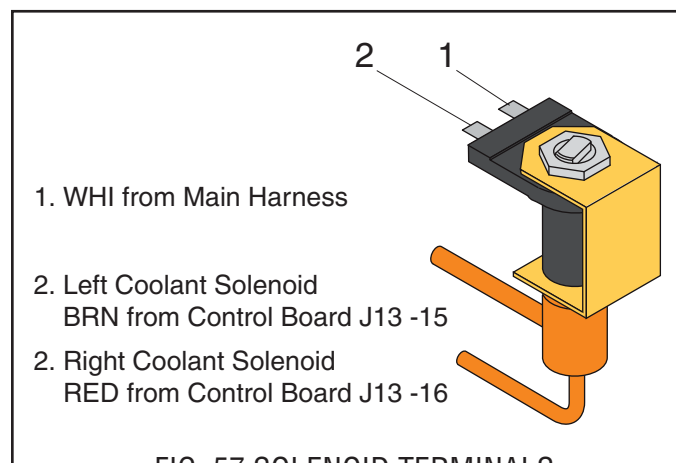

FIG. 57 SOLENOID TERMINALS

TEMPERATURE SENSOR

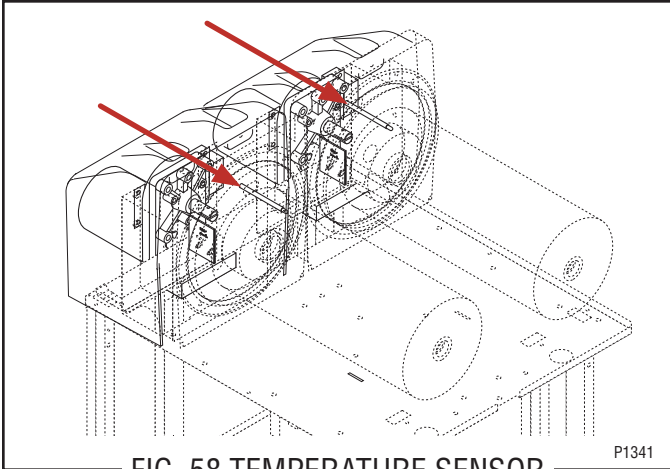

FIG. 58 TEMPERATURE SENSOR

Location:

The Temperature Sensor(s) are located inside the top rear of the cooling drum under the Auger Motor covers.

Test Procedures:

1. Remove the left side housing panel.
2. Connect a voltmeter, across the two leads of the temperature sensor (leave plug connected);  
The indication must be:  
a) Approx. 1.4 vdc @ 71° F  
b) Approx. 2.6 vdc @ 32° F

If voltage reading is 0v, the Control Board is not supplying the necessary 5v and should be replaced. If the reading stays at 5vdc, replace thermistor.

Alternate Test:

2. Disconnect the plug on thermistor leads and check resistance as indicated below.  
The indication must be:  
a) 5650 ohms @ 32° F ± 10%  
b) 2000 ohms @ 77° F ± 10%

If resistance reading is not within the range listed above, replace thermistor.

Removal and Replacement:

1. Remove the two #8-32 screws securing the auger motor cover to cooling drum mount and remove cover. Set aside for reassembly.
2. Disconnect the plug on the temperature sensor leads from the connector on the dispenser main harness.
3. Pull the temperature sensor from the tube at the top rear of the cooling drum and discard.
4. Push new temperature sensor into tube at the top rear of the cooling drum as far as it will go.
5. Refer to Fig. 59 and reconnect the wires.
6. Position auger motor cover on cooling drum mount and secure with two #8-32 locking screws.

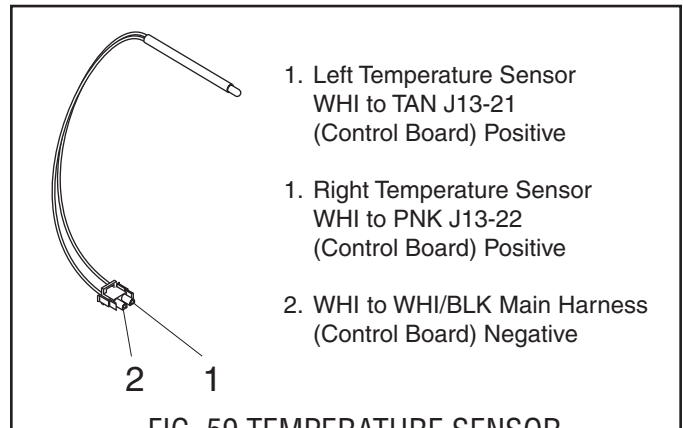

FIG. 59 TEMPERATURE SENSOR

**TORQUE SENSOR CIRCUIT BOARD**

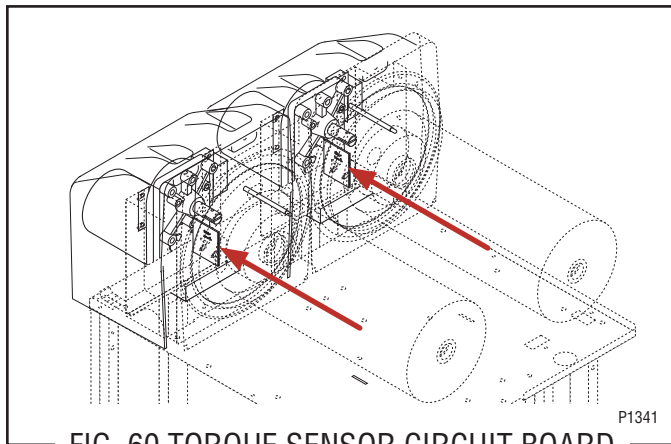

FIG. 60 TORQUE SENSOR CIRCUIT BOARD

Location:

The torque sensor circuit board is located on the rear of the cooling drum mount just left of center.

Test Procedures:

1. Place black meter lead at J1-3 (common) and red lead at J1-1 (signal). Set meter to 10 - 20volts DC scale. Turn on power switch.

**DO NOT TURN ON AUGERS!**

2. Using a strip of paper, momentarily block the light path between red LED and white phototransistor. If the meter displays 5vdc when blocked and 0v when unblocked, then the Torque Sensor is good. If there is no 5vdc reading, verify that both red and white sensors are clean.
3. If there is still no 5vdc reading when blocked, place the red meter lead at J1-2 and verify that there is 4.5vdc supplied to Torque Sensor. If there is no 5vdc supplied, check wiring between control board and Torque Sensor. If wiring is ok, then replace the main control board.

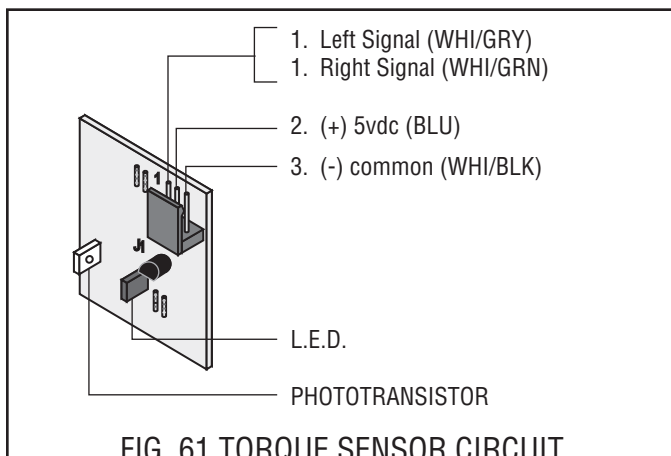

FIG. 61 TORQUE SENSOR CIRCUIT BOARD TERMINALS

Removal and Replacement:

1. Remove the two #8-32 locking screws securing the auger motor cover to the cooling drum mount.
2. Remove the cover and set aside for reassembly.
3. Remove the #8 locking screw on the lower right side of the auger motor mounting bracket securing the auger motor run capacitor. Set capacitor aside with wires attached.
4. Disconnect the auger motor plug from the connector on the main wiring harness.
5. Remove the three remaining #8 locking screws securing the auger motor mounting bracket to cooling drum mounting bracket.
6. Remove motor with mounting bracket, split pin/torsion spring bearings as an assembly and set aside for reassembly.

**NOTE:** When removing or installing the motor be sure the split pin in the motor shaft is turned to a position that will clear the torque sensor circuit board.

7. Disconnect the plug from the dispenser main wiring harness to the torque sensor circuit board.
8. Remove the #8-32 locking screw and washer securing torque sensor circuit board to the cooling drum mount.
9. Remove torque sensor circuit board and discard.
10. Install new torque sensor circuit board in the slot in the rear of the cooling drum mount and secure with a #8-32 locking screw and washer.
11. Reconnect wires.
12. Reinstall motor with mounting bracket, drip tray, split pin and torsion spring bearings using three #8 locking screws onto the cooling drum bracket.
13. Install the auger motor capacitor on the lower right side of the auger mounting bracket using the remaining #8 locking screw.
14. Connect the auger motor terminal to the terminal on the main wiring harness.
15. Reconnect wires.
16. Position the auger motor cover on the cooling drum mount and secure with two #8-32 locking screws.

## TRANSFORMER

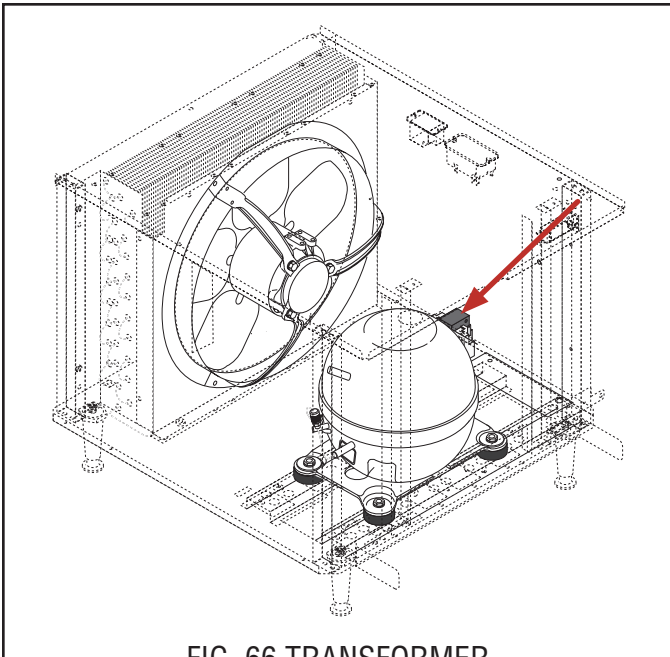

FIG. 66 TRANSFORMER

### Location:

The transformer is located inside dispenser on the lower right side of the chassis.

### Test Procedures:

1. Disconnect the dispenser from the power source.
2. Remove right side panel.
3. Connect the dispenser to the power source.
4. Connect a voltmeter from the WHI/BLU wire to the WHI/BLK wire on the transformer.

The indication must be:

- a) Aprox. 12.6 volts ac.

If voltage is present as described, the transformer is working properly.

If voltage is not present as described, refer to the Wiring Diagrams and check the main wiring harness.

5. Connect a voltmeter from the WHI wire to the BLK wire on the transformer.

The indication must be:

- a) 120 volts ac for 120 volt models.
- b) 230 volts ac for 230 volt models.

If voltage is present as described, replace transformer.  
If voltage is not present as described, refer to the Wiring Diagrams and check the main wiring harness.

### Removal and Replacement:

1. Disconnect the dispenser from the power source.
2. Remove right side panel.
3. Disconnect the four wires from transformer.
4. Disconnect the wiring harness from the plug on the transformer.
5. Remove the two #8-32 nuts securing the transformer to the chassis base. Remove transformer and discard.
6. Position new transformer on the chassis base, and secure with two #8-32 nuts.
7. Refer to Fig. 67 and reconnect the wires.

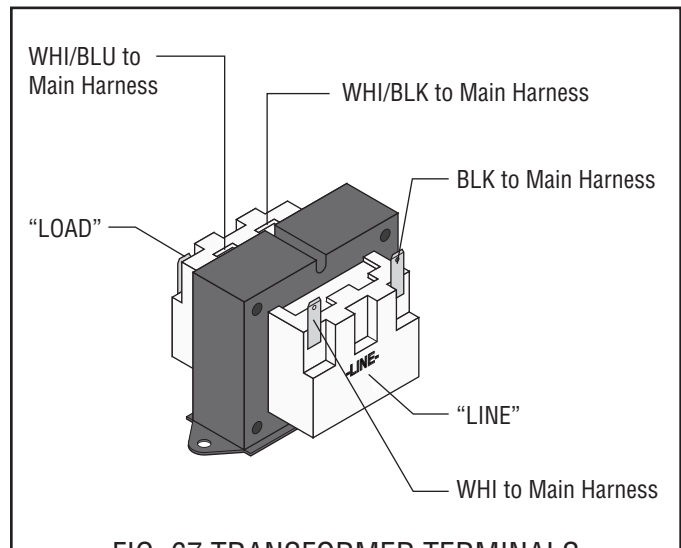

FIG. 67 TRANSFORMER TERMINALS

Liquid Autofill System

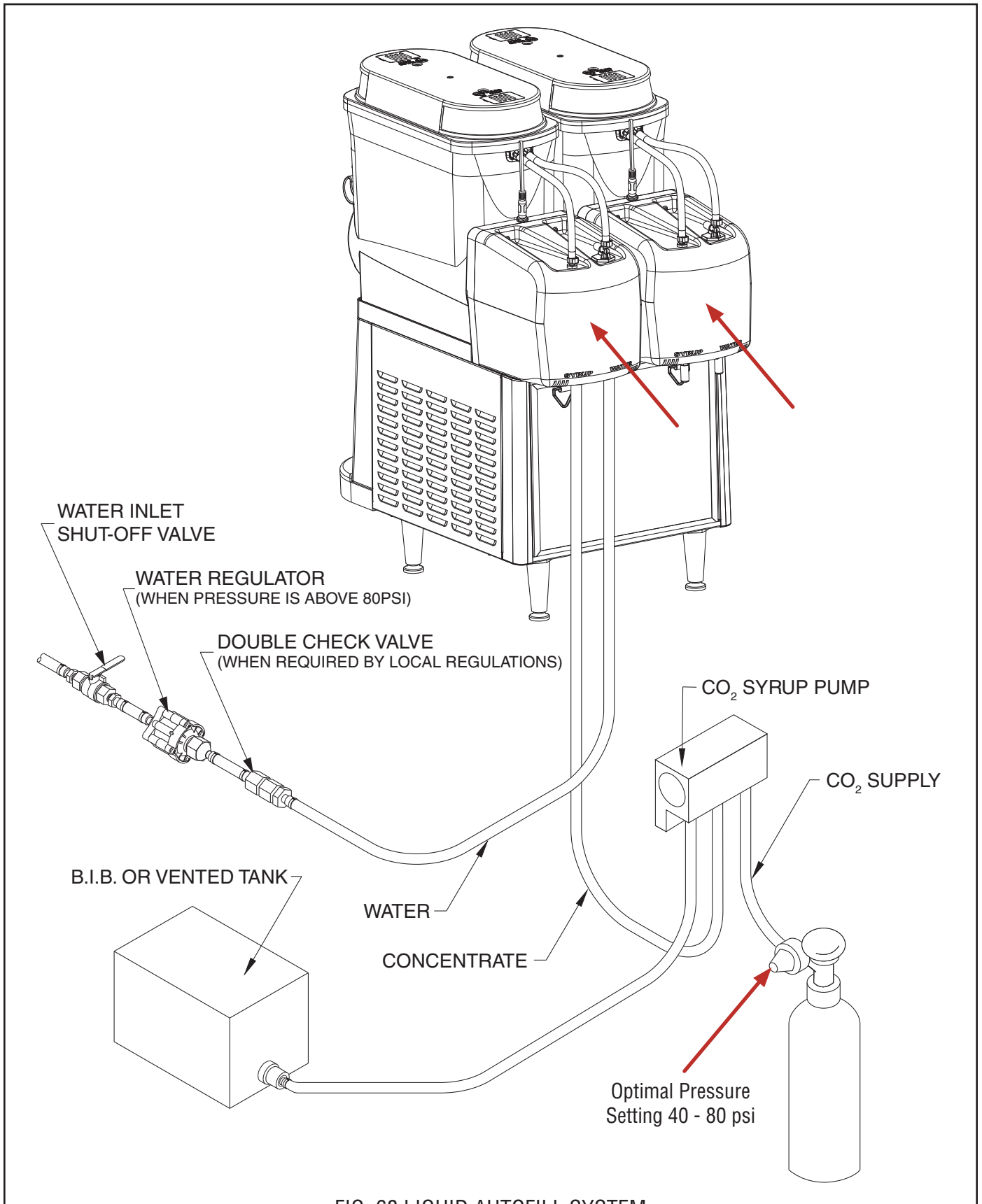

FIG. 68 LIQUID AUTOFILL SYSTEM

## SERVICE (continued)

### Liquid Autofill System

#### Location:

Under each hopper motor cover there are two constant flow (CF) valves, one for water and one for syrup. Located on top of the cover is a needle valve for adjusting water flow.

#### Test Procedure:

The water screw adjustment valve is used to set the product mix ratio, but only as long as the incoming water pressure is between 30-80 psi. Rotate the adjustment screw with a standard screwdriver. Turning the screw clockwise will decrease the water flow and counter-clockwise will increase water flow.

**NOTE:** If water source is not within the specification of water pressure requirement(s), a water booster pump will need to be installed and adjusted to maintain the 30 to 80 psi requirement.

CO2 Tank with Pressure Regulator is an alternate source used in conjunction with syrup CO2 pumps to move bag-in-box syrup product. Several factors are involved when setting the actual pressure because of product viscosities, length and positioning of lines (vertical or horizontal). Optimal psi range is 40-80. A typical set point is 65 psi.

Check for voltage at the Water valve solenoid between the WHT and WHT/YEL wires. The reading should be 120 vac for 120V machines, or 230 vac for 230V machines.

Check for voltage at the Syrup valve solenoid between the WHT and WHT/YEL wires. The reading should be 120 vac for 120V machines, or 230 vac for 230V machines.

If voltage is not present as indicated, replace solenoid valve(s).

#### Removal and Replacement:

1. Shut off and disconnect the product and water supply lines to the solenoid valves.
2. Disconnect the product and water supply lines to the hopper from the solenoid valves.
3. Remove the auger motor cover.
4. Remove WHI and WHT/YEL wires from solenoid valve.
5. Remove YEL (Common Terminal) and WHT/YEL (N/O Terminal) wires from the pressure switch.
6. Replace the faulty solenoid valve with new valve.
7. Reconnect WHI and WHT/YEL wires to solenoid valve.
8. Reconnect YEL and WHT/YEL wires to the pressure switch.
9. Reinstall auger motor cover.
10. Reconnect the supply lines from the solenoid valves to the hopper.
11. Reconnect the water and syrup supply lines to the solenoid valves.
12. Turn on the water and syrup supply.
13. Inspect for leaks.

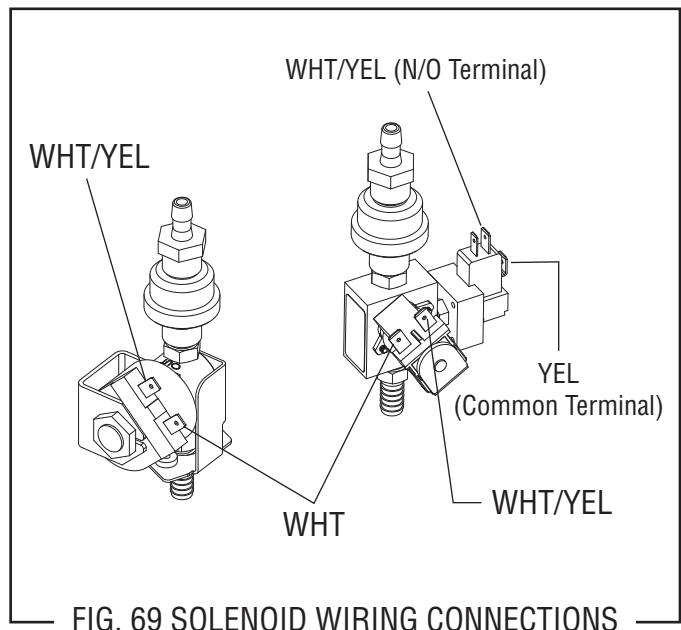
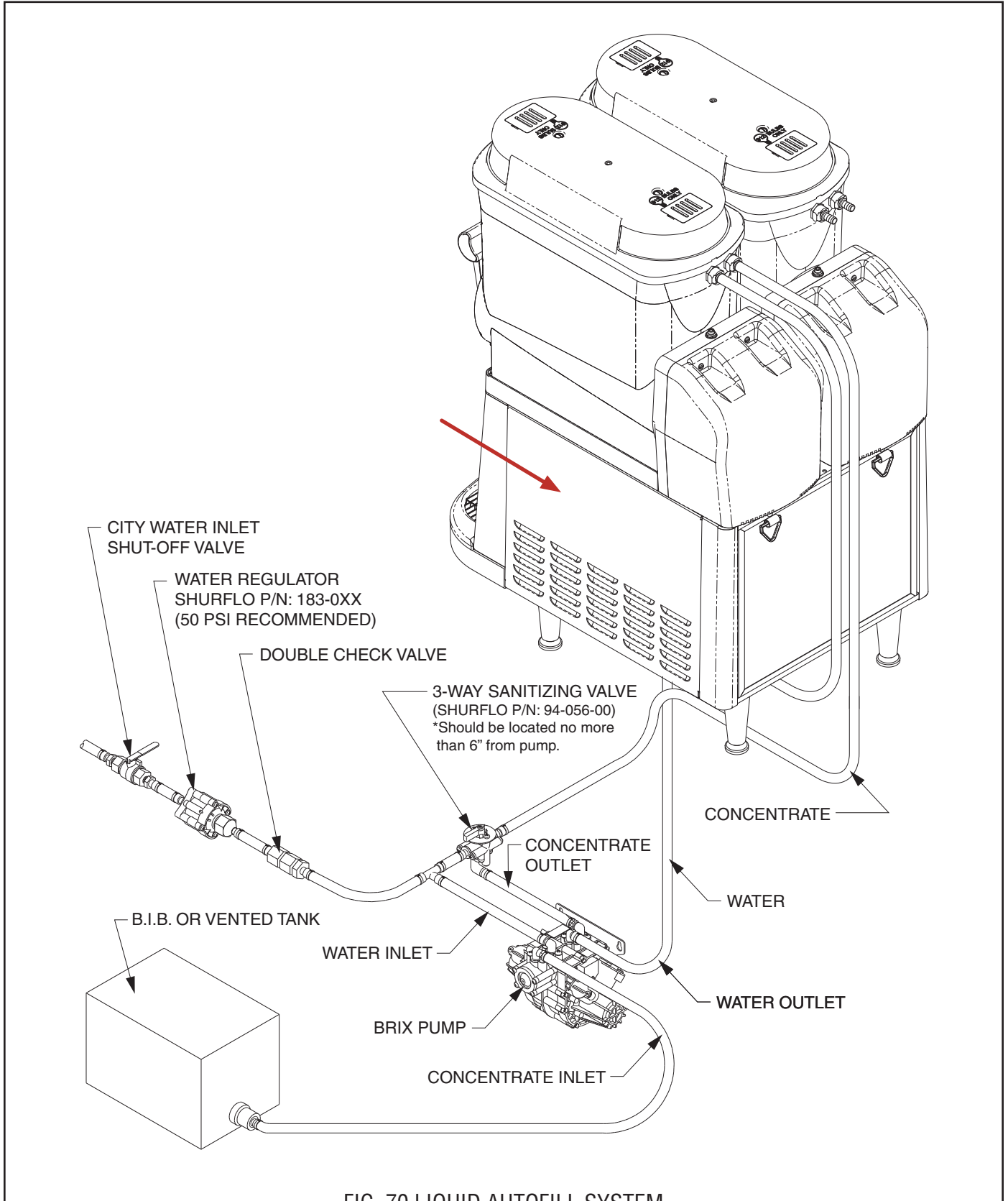

FIG. 69 SOLENOID WIRING CONNECTIONS

Liquid Autofill System



## SERVICE (continued)

### Liquid Autofill System

#### Location:

Located inside the right access cover are the Syrup and water solenoid valves for each hopper. Some models will have only syrup valves and lines.

**NOTE:** Refer to manufacturers instructions for all components on the outside of the machine.

#### Proper Installation:

- The Brix pump should be placed as close to the concentrate supply as possible.
- The Brix pump mounting placement should be the same level or slightly higher than the concentrate BIB.
- The sanitizing valve should be no more than 6” from the brix pump.
- Insure ease of access to the brix pump and sanitize valve for sanitizing procedure.

#### Test Procedure:

A water regulator is used to maintain pressure of 50 psi.

Check for voltage at the Syrup valve solenoid between the WHT and RED wires for the right valve(s) or between the WHT and BLU wires for the left valve(s). The reading should be: 100 vac for 100V machines, 120 vac for 120V machines, or 230 vac for 230V machines.

If voltage is not present as indicated, replace solenoid valve(s).

Check for voltage at the Water valve solenoid between the WHT and RED wires for the right valve(s) or between the WHT and BLU wires for the left valve(s). The reading should be: 100 vac for 100V machines, 120 vac for 120V machines, or 230 vac for 230V machines.

If voltage is not present as indicated, replace solenoid valve(s).

#### Removal and replacement:

1. Shut off and disconnect the product and water supply lines to the machine.
2. Remove the right side panel.
3. Disconnect the product inlet and outlet lines at the solenoid.
4. Remove WHI and RED or BLU wires from solenoid valve.
5. Replace the faulty solenoid valve with new valve.
6. Reconnect WHI and RED or BLU wires to solenoid valve.
7. Reconnect the product inlet and outlet lines at the solenoid.
8. Install the right side panel.
9. Turn on the water and product supply.
10. Inspect for leaks.

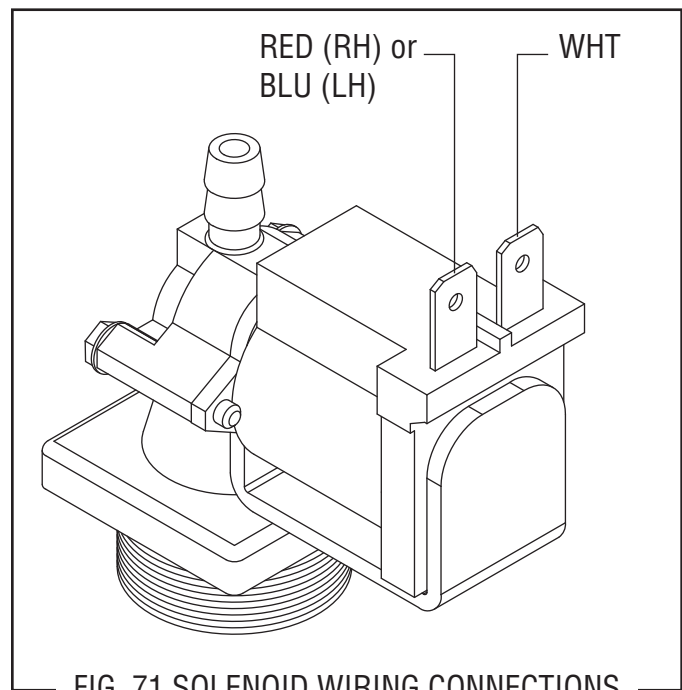
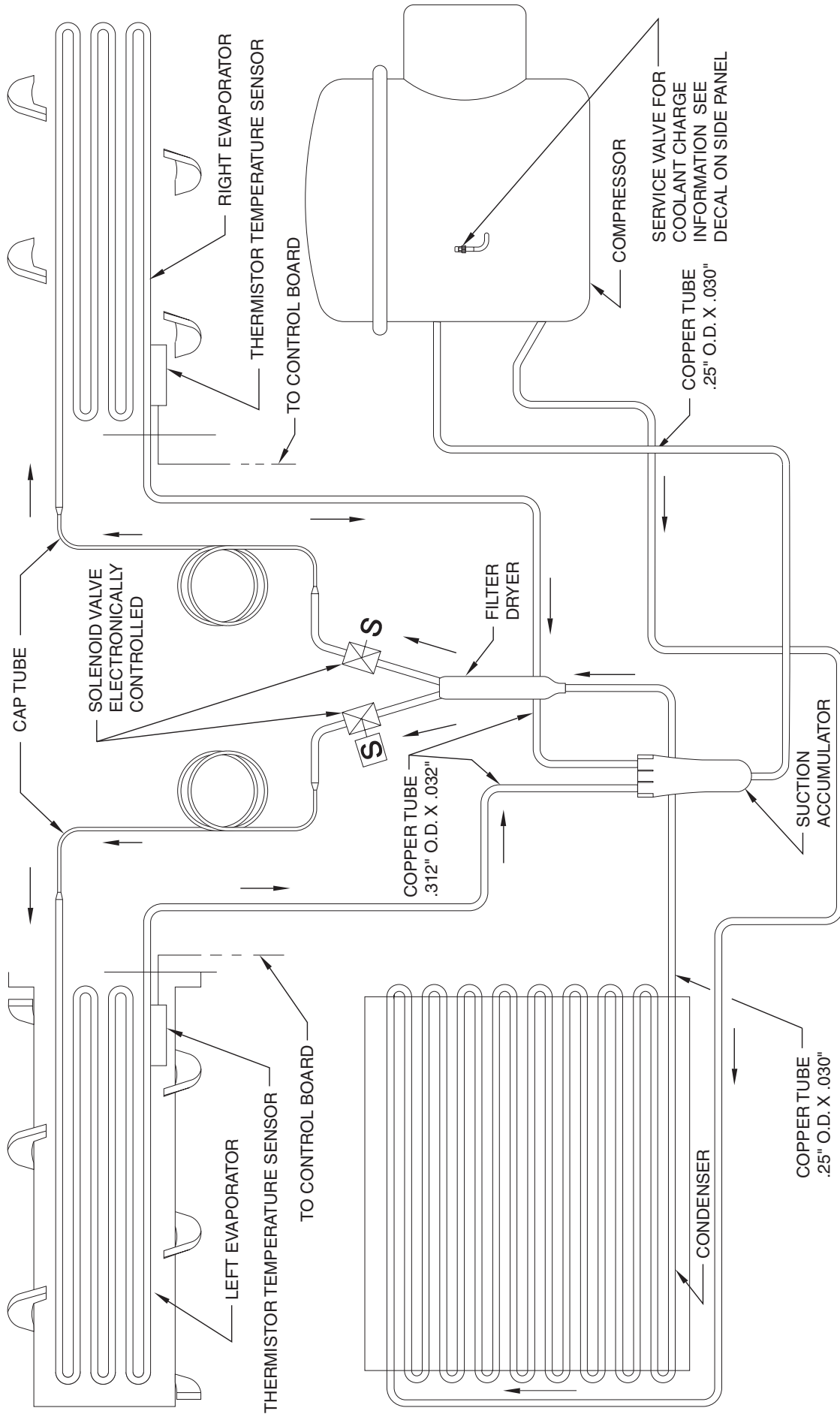
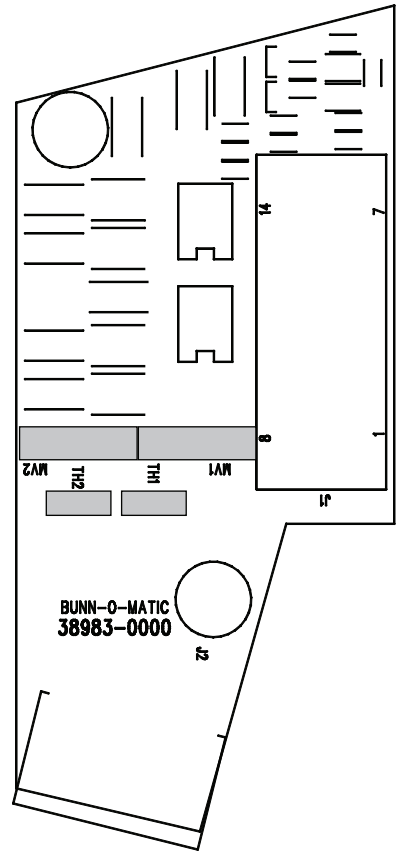
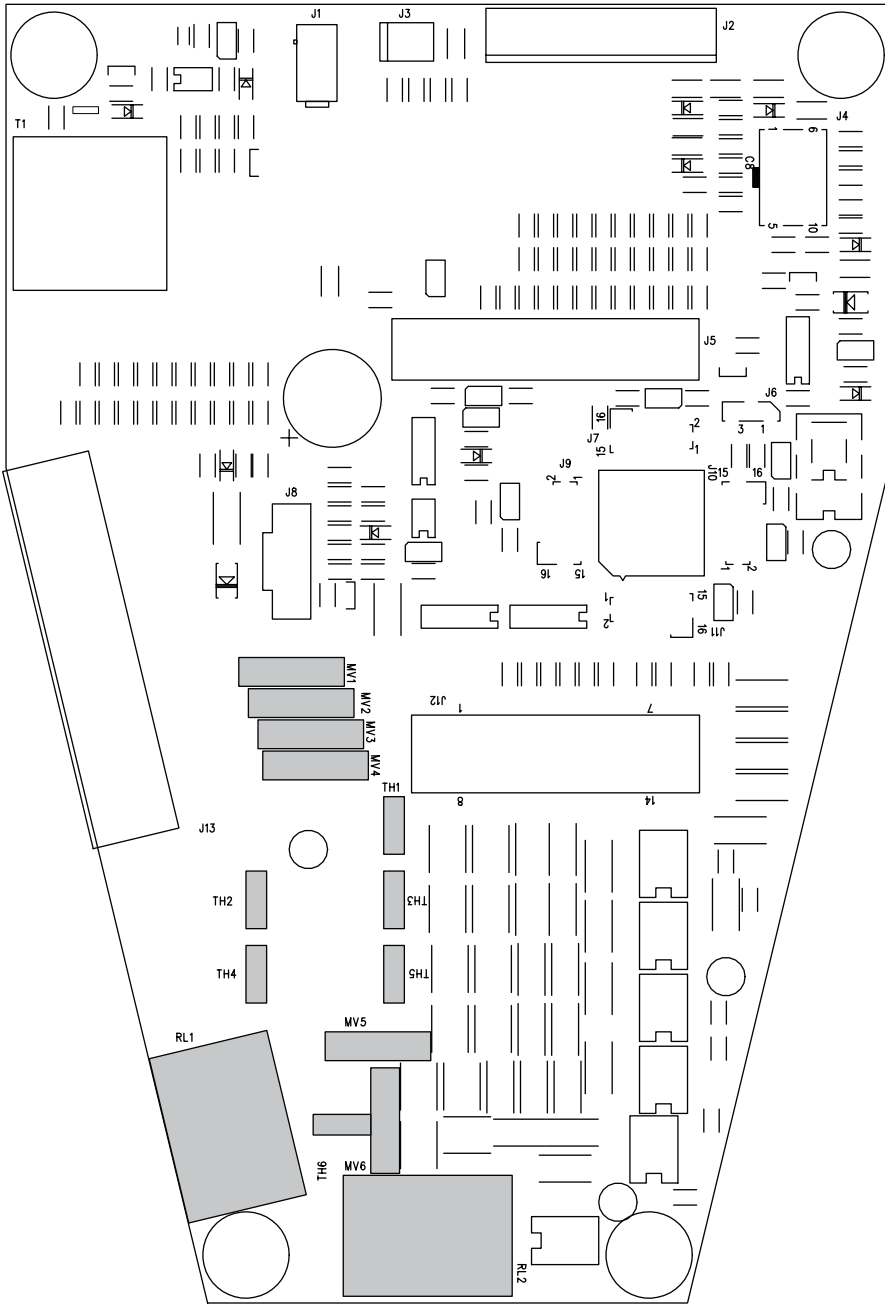

FIG. 71 SOLENOID WIRING CONNECTIONS

# COOLANT SCHEMATIC



# TRIAC MAPS



**LIQUID AUTO-FILL BOARD**

## TRIACS

TH1 & MOV3	controls	Left solenoid	@ J13-15
TH2 & MOV1	controls	Compressor Relay	@ J13-17
TH3 & MOV4	controls	Fan	@ J13-14
TH4 & MOV2	controls	Right solenoid	@ J13-16
TH5 & MOV5	controls	Left Auger	@ J13-2 Reverse & J13-3 Forward
TH6 & MOV6	controls	Right Auger	@ J13-13 Reverse & J13-1 Forward

## LIQUID AUTO-FILL TRIACS

TH1 & MOV1	controls	Right fill solenoid	@ J2-9
TH2 & MOV2	controls	Left fill solenoid	@ J2-4

## INPUT AND OUTPUT CHART

**J1 connector - black is TIC board ground and white is data wire.**

**J2 connector for touch pad/membrane switch (see touch pad pin out test) .**

**J5 connector for liquid crystal display.**

**J12 connector for models with Autofill option.**

**J13 connector for Main harness**

PIN NUMBER	WIRE COLOR AND GAUGE	FUNCTION	COMPONENT	VOLTAGE
1	Red/Black 18	Output	Right Auger Motor	120VAC
2	Brown/White 18	Output	Left Auger Motor	120VAC
3	Brown/Black 18	Output	Left Auger Motor	120VAC
4	Black 18	<b>Supply</b>	PC Board	<b>120VAC</b>
5	White 18	<b>Neutral</b>	PC Board	<b>Neutral</b>
6	Not Used	Not Used	Not Used	Not Used
7	Violet 18	Output/Switched	Lamp Relay	-12VDC
8	White/Blue 18	<b>Supply</b>	PC Board	<b>12VAC</b>
9	White/Black 22	Board Ground	Sensors	-5VDC
10	Yellow 22	Input/Signal	Hot Gas Temp	*
11	Blue 22	Output	Torque Sensors	5VDC
12	White/Black 22	Output	Torque Sensors	5VDC
13	White/Red 18	Output	Right Auger Motor	120VAC
14	Gray 18	Output	Condenser Fan	120VAC
15	Brown 20	Output	Left Solenoid	120VAC
16	Red 20	Output	Right Solenoid	120VAC
17	Orange 18	Output	Compressor Relay	120VAC
18	Not Used	Not Used	Not Used	Not Used
19	Blue/Black 18	Output	Lamp Relay	+12VDC
20	White/Black 18	<b>Supply</b>	PC Board	<b>12VAC</b>
21	Tan 22	Input/Signal	Left Temp Sensor	*
22	Pink 22	Input/Signal	Right Temp Sensor	*
23	White/Gray 22	Input/Signal	Left Torque Sensor	0 or 5VDC
24	White/Green 22	Input/Signal	Right Torque Sensor	0 or 5VDC

**\* With sensor disconnected you will read +5VDC, but when connected, voltage will vary according to temperature. To check sensor, see repair section.**

**SCHEMATIC WIRING DIAGRAM ULTRA-2 AF**

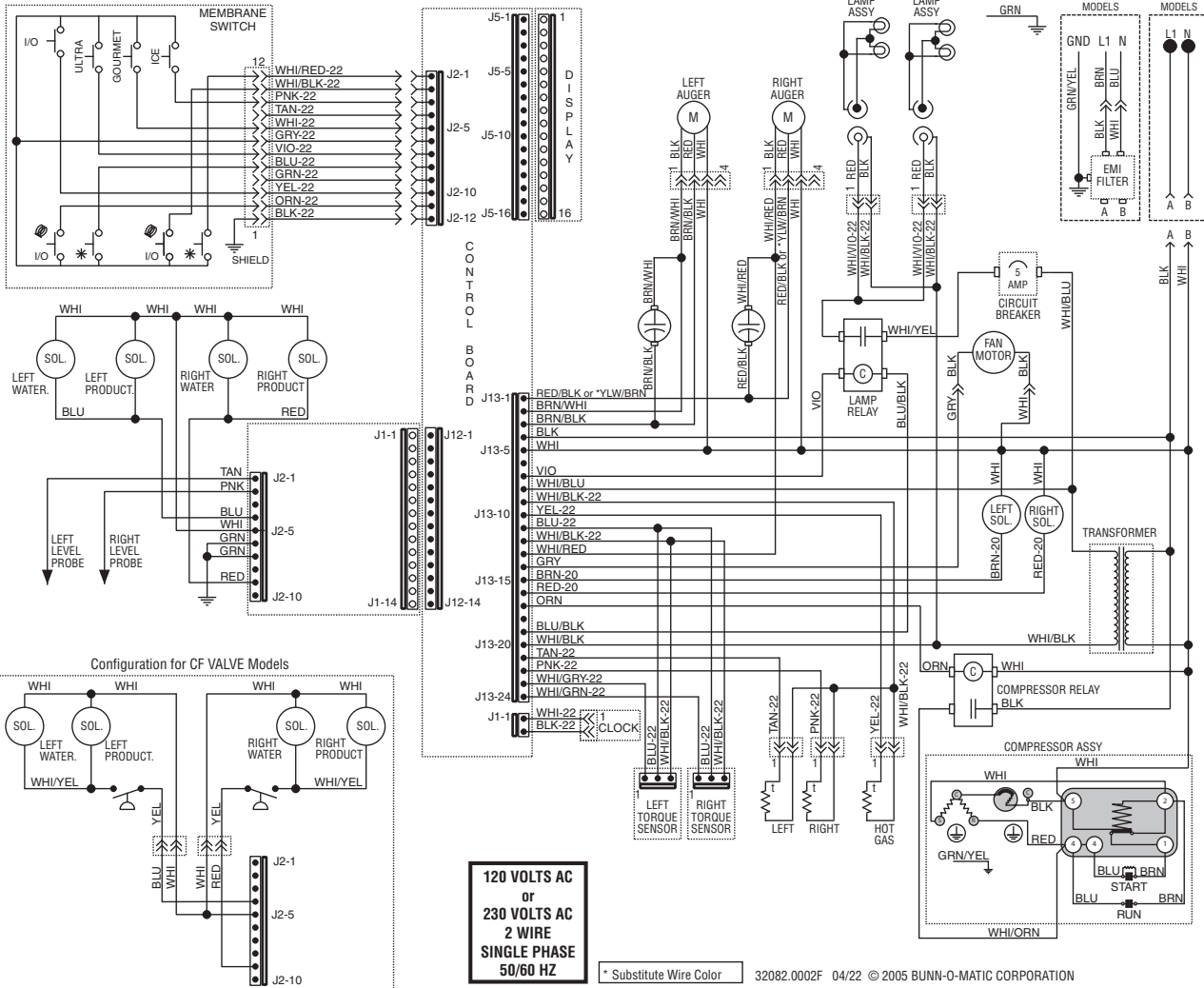

Thermal Transfer Stock  
 W/Tape Over-Laminate  
 Black Ink  
 Finished Size: 6.375" x 5.0"  
 ~ 45% Reduction

# SCHEMATIC WIRING DIAGRAM ULTRA-2 B AF

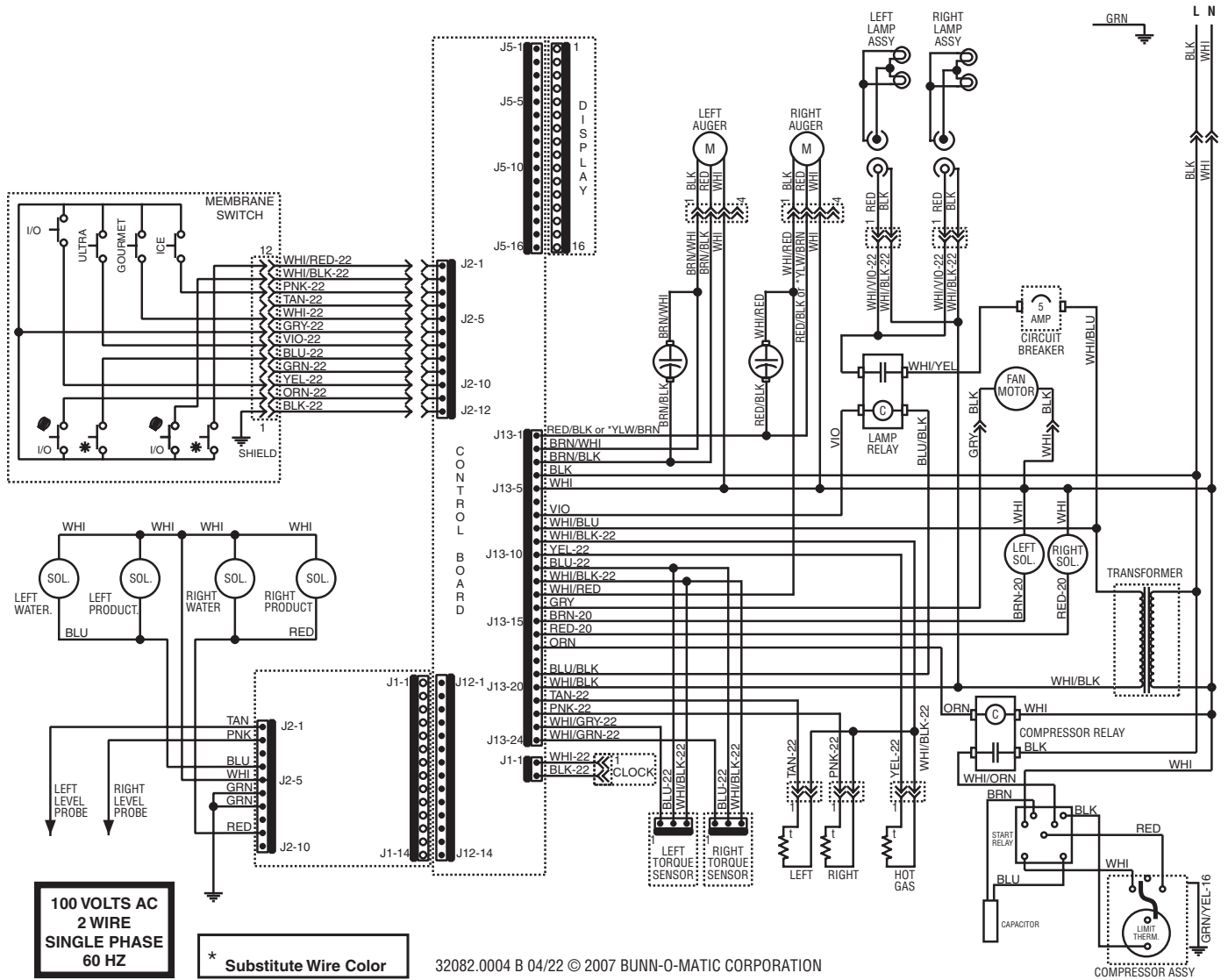

**100 VOLTS AC  
2 WIRE  
SINGLE PHASE  
60 HZ**

**\* Substitute Wire Color**

32082.0004 B 04/22 © 2007 BUNN-O-MATIC CORPORATION

# SCHEMATIC WIRING DIAGRAM PAFP

