

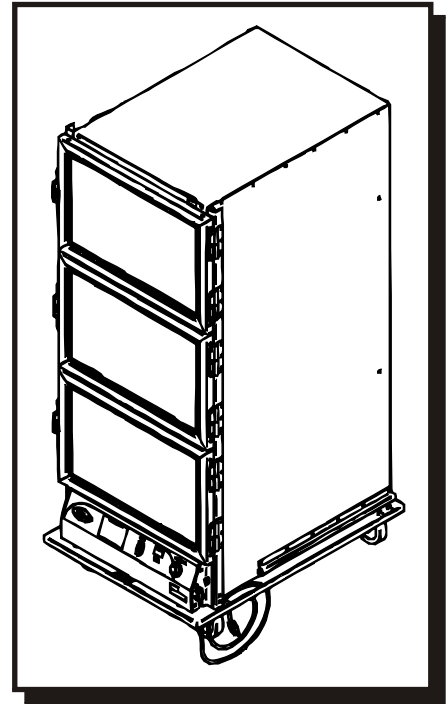

Innovative Foodservice Equipment
Designed for Performance, Service and Value.

**INSTALLATION
AND
OPERATING INSTRUCTIONS**

Cinnabon™ Proofing Cabinet
PICA70-32-A (ED)



**INTENDED FOR OTHER THAN HOUSEHOLD USE
RETAIN THIS MANUAL FOR FUTURE REFERENCE
UNIT MUST BE KEPT CLEAR OF COMBUSTIBLES AT ALL TIMES**



WARNING: For your safety do not store or use gasoline or other flammable vapors or liquids in the vicinity of this or any other appliance. Keep the area free and clear of combustibles. (See ANZI Z83.14B, 1991)



WARNING: Improper installation, adjustment, alteration, service or maintenance can cause property damage, injury or death. Read the Installation, Operating and Maintenance Instructions thoroughly before installing or servicing this equipment.



This equipment has been engineered to provide you with year round dependable service when used according to the instructions in this manual and standard commercial kitchen practices.



Phone: +1 (214) 421-7366
Fax: +1 (214) 565-0976
Toll Free: +1 (800) 441-1601
Website: www.BevLes.com
E-mail: sales@BevLes.com

P/N 780089 10/08

BevLes
729 Third Avenue
Dallas, TX 75226

IMMEDIATELY INSPECT FOR SHIPPING DAMAGE

All containers should be examined for damage before and during unloading. The freight carrier has assumed responsibility for its safe transit and delivery. If equipment is received damaged, either apparent or concealed, a claim must be made with the delivering carrier.

A) Apparent damage or loss must be noted on the freight bill at the time of delivery. It must then be signed by the carrier representative (Driver). If this is not done, the carrier may refuse the claim. The carrier can supply the necessary forms.

B) Concealed damage or loss if not apparent until after equipment is uncrated, **a request for inspection must be made to the carrier within 15 days.** The carrier should arrange an inspection. **Be certain to hold all contents and packaging material.**

BevLes Company takes pride in the design and quality of our products. When used as intended and with proper care and maintenance, you will experience years of reliable operation from this equipment. To ensure best results, it is important that you read and follow the instructions in this manual carefully.

Installation and start-up should be performed by a qualified installer who has thoroughly read, understands and follows these instruction.

If you have questions concerning the installation, operation, maintenance or service of this product, write Technical Service Department BevLes Company, Inc., 729 Third Avenue, Dallas, TX 75226.

1. SAFETY PRECAUTIONS

Before installing and operating this equipment be sure everyone involved in its operation is fully trained and aware of all precautions. Accidents and problems can result by a failure to follow fundamental rules and precautions.

The following words and symbols, found in this manual, alert you to hazards to the operator, service personnel or the equipment. The words are defined as follows:



DANGER: This symbol warns of imminent hazard which may result in serious injury or death.



WARNING: This symbol refers to a potential hazard or unsafe practice, which could result in serious injury or death.



CAUTION: This symbol refers to a potential hazard or unsafe practice, which may result in minor or moderate injury or product or property damage.



NOTICE: This symbol refers to information that needs special attention or must be fully understood even though not dangerous.



2. GENERAL INFORMATION

THIS MANUAL SHOULD BE RETAINED FOR FUTURE REFERENCE



WARNING: Check the data plate on this unit before installation. Connect the unit only to the voltage and frequency listed on the data plate. Connect only to 1 phase as listed on the data plate.







WARNING: Electrical and grounding connections must comply with the applicable portions of the national electrical code and/or other local electrical codes.







NOTICE: The unit when installed, must be electrically grounded and comply with local codes, or in the absence of local codes, with the national electrical code ANSI/NFPA70 latest edition. Canadian installation must comply with CSA-STANDARD C.22.2 Number 0 M1982 General Requirements- Canadian Electrical Code Part II, 109-M1981- Commercial Cooking Appliances.





 **WARNING:** In Europe, appliance must be connected by an earthing cable to all other units in the complete installation and thence to an independent earth connection in compliance with EN 60335-1 and/or local codes. 

 **NOTICE:** This equipment has been engineered to provide you with year round dependable service when used according to the instructions in this manual and standard commercial kitchen practices. 

 **WARNING:** Do not use oven cleaners, caustic solutions or mechanical means to clean the appliance as they will damage the interior/exterior surface. 

 **WARNING: This appliance must be serviced by an Authorized Service Technician only. Disconnect the power supply before cleaning or servicing the proofer.** 
 Regular and thorough cleaning will help to keep the proofer operating properly. If service is required, contact an Authorized Service Agency, your dealer or the factory to obtain a qualified technician for the required maintenance/service.

 **WARNING:** Disconnect device from electrical power supply and place a Tag Out-Lockout on the power plug, indicating that you are working on the circuit. 

IMPORTANT FOR FUTURE REFERENCE

Please complete this information and retain this manual for the life of the equipment. For Warranty Service and/or Parts, this information is required.

 Model Number Serial Number Date Purchased

TABLE OF CONTENTS

<u>SECTION</u>	<u>ITEM</u>	<u>PAGE</u>
1	Safety Precautions.....	2
2	General Information	2
3	Setting-Up.....	4
4	Operation	4
5	Maintenance	5
6	Troubleshooting Tips	6
7	Replacing Electrical Components.....	8
8	Dimensions.....	9
9	Wiring Diagram.....	11
10	Parts List w/Exploded Views	12
11	Warranty.....	19

3. SETTING-UP

1. Open the carton containing the pan supports and install all supports in cabinet. Install the pan supports from the bottom up. Skip 2 slots between each pan support to achieve a 4.5" spacing.
2. Install eleven (11) 23" x 32" chrome plated wire shelves on the pan supports.
3. Make certain that the Lexan[®] water pan cover is properly installed over the cast water pan and over the louvers in front of the pan.
4. Insert a standard 18"x 26" sheet pan (not provided with proofer) in the slides under the base of the cabinet. This will serve as a drip pan when cabinet is in use.
5. Place the cabinet in the location where it will be operated. When in position secure the brakes on the front two wheels. These brakes should always be locked when the cabinet is in use.

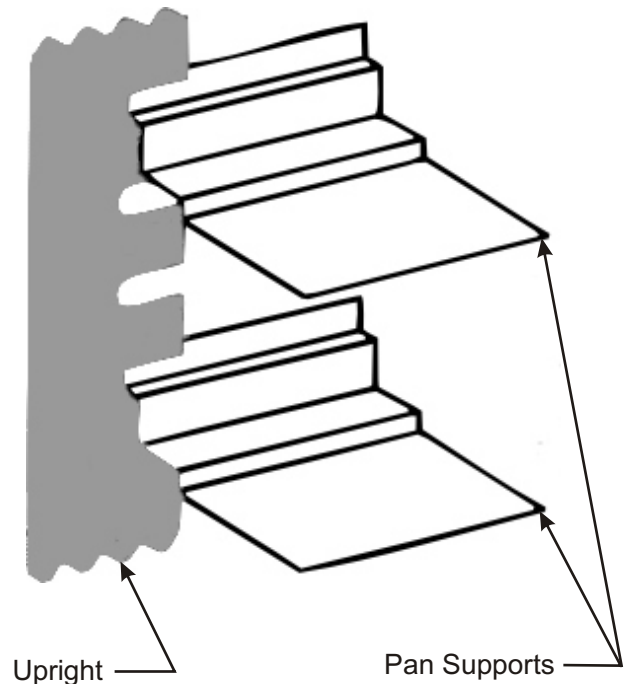

4. OPERATION

1. Make certain that your unit is properly plugged into the correct power source as specified on the data plate. (Cord should be guided to the back of the unit through the cord guide. To install or remove cord from guide, pull out inner guide channel.)
2. Verify that wheel brakes are in locked position (front two casters).
3. Inspect humidity pan for proper water level (1/2 to 3/4 full) and verify the Lexan[®] water pan cover is properly in place. (Filling humidity pan at the beginning or end of each day will usually ensure continued humidity throughout the proofing process in most applications).

Refer to picture of control panel on page 5 for the following steps.

4. Push the power switch to the "ON" Position. Always use this switch to turn the unit "ON" or "OFF".
5. Set the temperature control to the desired cabinet temperature. 90°F to 110°F is recommended as a starting position. Increase or decrease the cabinet temperature as needed to best suit your application.

To select desired cabinet temperature:

- A. Press SET key under cabinet temperature display.
 - B. Press INCREASE key or DECREASE key to adjust cabinet temperature.
 - C. Press SET key to lock-in desired cabinet temperature. (If you don't press the SET key the temperature setting will revert back to previous setting).
6. Set the humidity control to the #3 or #4 position. This can be increased if necessary to suit your specific application.
 7. Make certain that a standard 18" x 26" sheet pan (not provided with proofer) has been inserted as a drip pan in the slides on the bottom "outside" of the cabinet.
 8. Verify that the doors are closed and latched.

9. Allow approximately 30 - 45 minutes for the cabinet to achieve the necessary temperature and humidity that you desire.
10. The cabinet is now ready for product placement and the start of the proofing process.

Note: Different product, or even different batches of the same product may require different cabinet temperature and humidity settings. This may result in longer, or possibly even shorter proofing times.

OPERATING TIPS

Always inspect wheel brakes before attempting to move the cabinet. Make certain that brakes are in the locked position before placing cabinet into operation.

During "cold" start-up you may want to add hot tap water and set the Humidity Control to the HI setting for 10 to 15 minutes to accelerate the humidity process. **Remember to re-set the Humidity Control back to the desired setting before beginning the proofing process.** Once the cabinet has been loaded with product and the proofing process has started, the proofer doors should not be opened until proofing has been completed.

The 18" x 26" sheet pan (not provided with proofer) that serves as a drip pan under the cabinet base should be checked, and if necessary, emptied at the end of each day.

The cabinet should be cleaned whenever necessary. It should be thoroughly cleaned at least once a week.

Note: It is recommended that humidity be kept at the minimum level that is practical for your operation. Excessive humidity with condensation on the walls and/or base of the cabinet is not considered desirable.

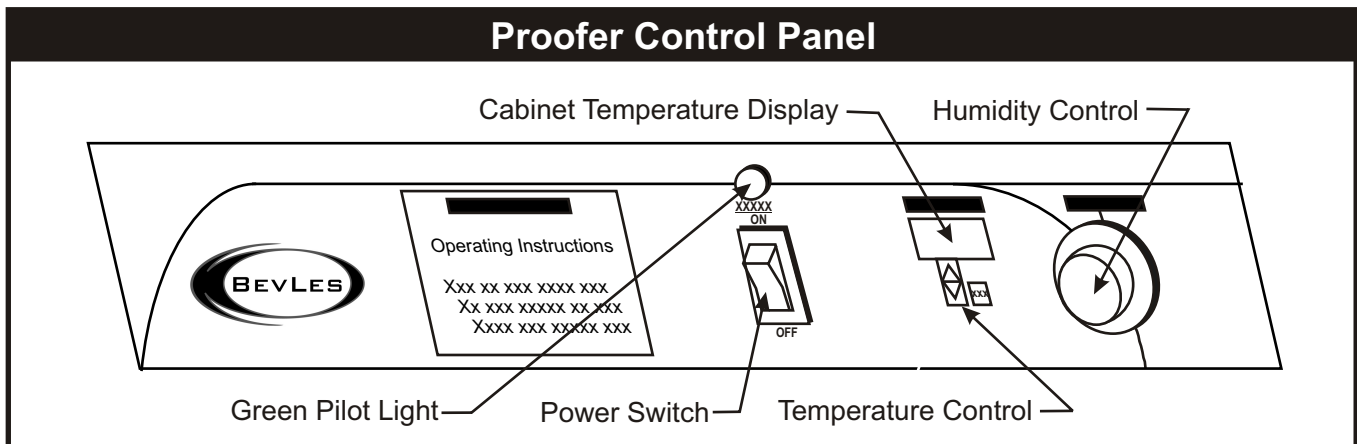

5. MAINTENANCE

SAFETY AND HEALTH

BevLes Proofing Cabinets meet all cUL and NSF requirements. Always operate this proofer in accordance with the operating instructions found in this manual. Never remove the humidity-heating module without first disconnecting (unplugging) the unit from its power source. The cabinet is designed and built for easy cleaning. It should be cleaned frequently as described in the maintenance section.

MAINTENANCE

Cleaning: This cabinet was designed and built for maximum sanitation. It is not self cleaning, so it should be cleaned frequently with soap and water.

1. NEVER USE STEEL WOOL OR CAUSTIC CLEANING COMPOUNDS.
2. Make sure that the unit is turned OFF and unplugged from the electrical service.
3. Remove the clear Lexan[®] water pan cover and the louvered side covers from the humidity-heating module.

4. Remove the wire shelves, pan supports and vertical uprights.
5. Remove the vent from the rear wall.
6. Clean inside of cabinet with soap and water. Clean clear Lexan[®] water pan cover and Lexan[®] doors with soft sponge, soap and water.
NEVER USE HARSH CLEANING SUBSTANCES OR ABRASIVES TO CLEAN LEXAN[®] SURFACES, OR ANY OTHER CABINET SURFACES INCLUDING THE CAST ALUMINUM WATER PAN.
7. Remove and clean the 18" x 26" drip pan (not provided with proofer) from under the cabinet base.

We suggest that you clean the water pan at least every two weeks with a solution of white vinegar and hot water. Allow white vinegar to remain in water pan overnight. Then use a soft cloth to wipe away any mineral buildup. If necessary, the humidity-heating module can be removed by loosening the two (2) black knurled knobs (one located at each side on the module on the exterior of the cabinet). The module can be pulled out of cabinet for additional cleaning.

IF REPLACEMENT PARTS ARE EVER REQUIRED, ONLY USE PARTS THAT HAVE BEEN APPROVED BY BEVLES COMPANY, INC.

ASSISTANCE / SERVICE

Should you ever require assistance or service contact the BevLes manufacturing facilities at (800) 441-1601 or (214) 421-7366. When you phone please have the model number and serial number of the proofer. This will assist our service technicians in providing you with immediate assistance. You may want to briefly review the Troubleshooting Tips before you contact our factory.

6. TROUBLESHOOTING TIPS

No Power

If your proofer fails to start when the power is applied via power switch:

1. Check to see if the unit is properly plugged into correct power source as specified on the data plate.
2. Check to see that your power source (wall receptacle) has power - inspect circuit breaker.
3. Disconnect power cord and visually inspect for any damage.
4. Contact the BevLes Technical Service Department for assistance.

Excessive Humidity

If your proofer is producing excessive humidity:

1. Check the setting on the humidity control (white knob) to see if it is set where you normally operate at.
2. Check the base of the cabinet to see if the excess humidity is draining through the drain hole in the center of the base.
3. Contact the BevLes Technical Service Department for assistance.

No Humidity

If your proofer is producing no humidity, or considerably less than normally achieved:

1. Inspect water level in the water pan.

2. Check the setting on the humidity control (white knob) to see if it is set where you normally operate at.
3. Check to see if the cabinet doors are tightly closed.
4. Make certain that the humidity-heating module's one inch air flow opening (at rear of module) is behind the cabinet back vent that hangs on the rear wall of the cabinet.
5. Make certain that the clear Lexan[®] water pan cover is correctly positioned over the entire water pan and the louvers located in front of the water pan.
6. Verify that the fan blower is operating.
7. Contact the BevLes Technical Service Department for assistance.

Excessive Heat

If your proofer temperature is higher than normal:

1. Check the setting on the temperature control (60°-125°F) to see if it is set where you normally operate at.
2. Check the ambient room temperature to see if it is greater than your desired proofing temperature.
3. Contact the BevLes Technical Service Department for assistance.

No Heat

If your proofer is producing no heat, or considerably less than you normally achieve:

1. Check the setting on the temperature control (60°-125°F) to see if it is set where you normally operate at.
2. Check to see if the cabinet doors are completely closed.
3. Make certain that the humidity-heating module's one inch air-flow opening (at rear of module) is behind the cabinet back vent that hangs on the rear wall of the cabinet.
4. Verify that the fan blower is operating.
5. Contact the BevLes Technical Service Department for assistance.

You can contact the BevLes Technical Service Department at (800) 441-1601 or (214) 421-7366. When you phone please have the model number and serial number of the proofer. This will assist our service technicians in providing you with immediate assistance.

7. REPLACING ELECTRICAL COMPONENTS

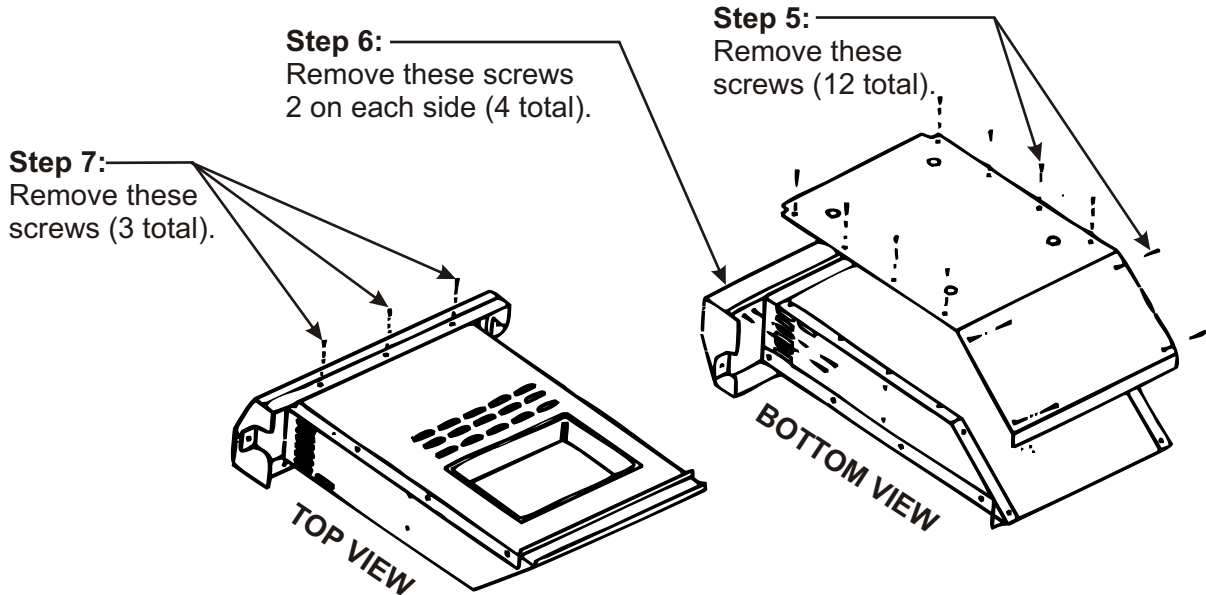

TO REPLACE ELECTRICAL COMPONENTS ON PROOFER MODEL: PICA70-32-A (ED)

1. Make sure the unit is turned off and unplugged from the electrical service.
2. Remove the power cord from the cord guide at the side of the cabinet.
3. Remove the two (black) knurled knobs (one located at each end of the control panel).
4. Pull the module out from the cabinet.

Refer to drawings above for steps 5,6 and 7.

5. Remove the screws from the bottom of the module. (6 screws on each side, total of 12).
6. Remove screws from the back side of the control panel. (2 screws per side, total of 4).
7. Remove screws from the top edge of the control panel. (3 screws total).
8. Electrical components are now exposed and can be serviced as necessary.

After installing new components, reverse the above steps. Make certain that the one inch air-flow opening at the back of the module is up behind the cabinet's back vent hanging on the rear wall.

Refer to wiring diagrams on page 11 for additional information.

8. DIMENSIONS

DIMENSIONS - PICA70-32-A (ED)

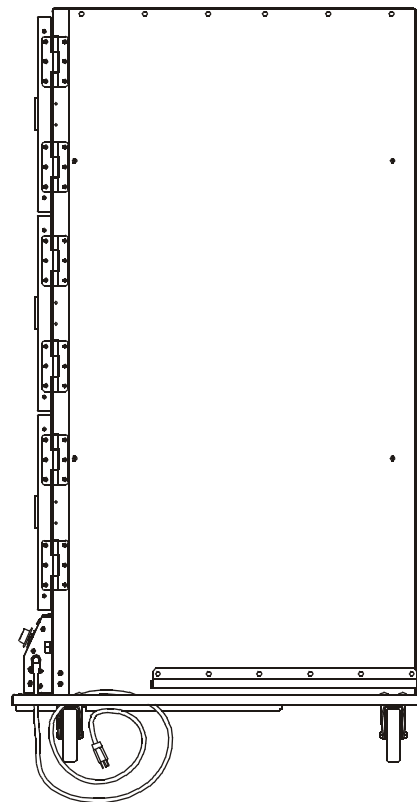
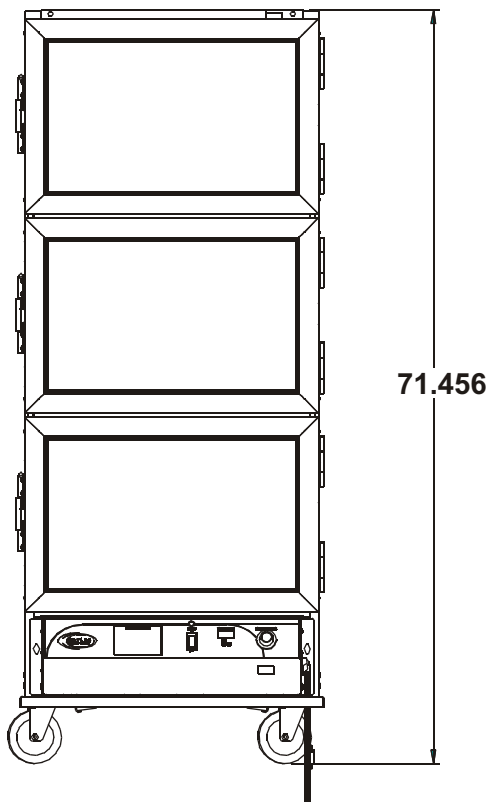
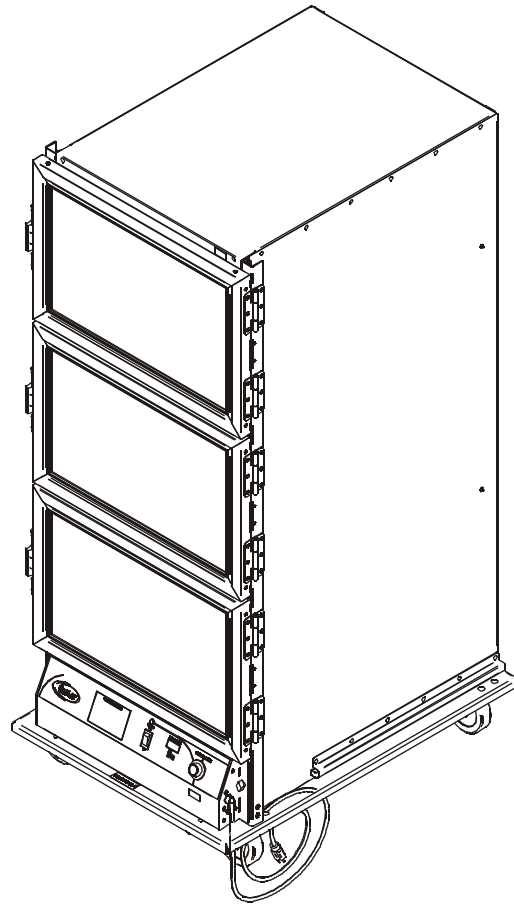
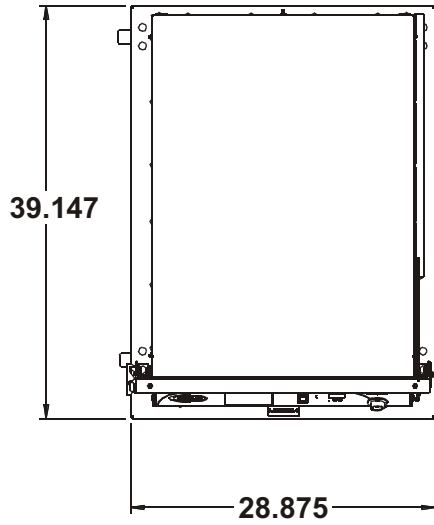

DIMENSIONS - BOTTOM MODULE

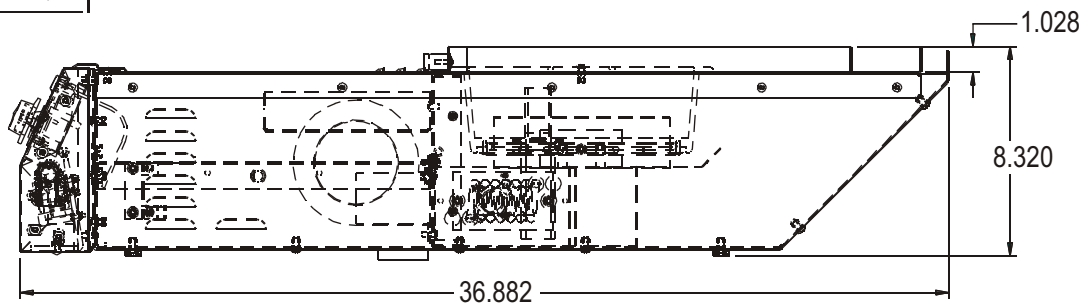
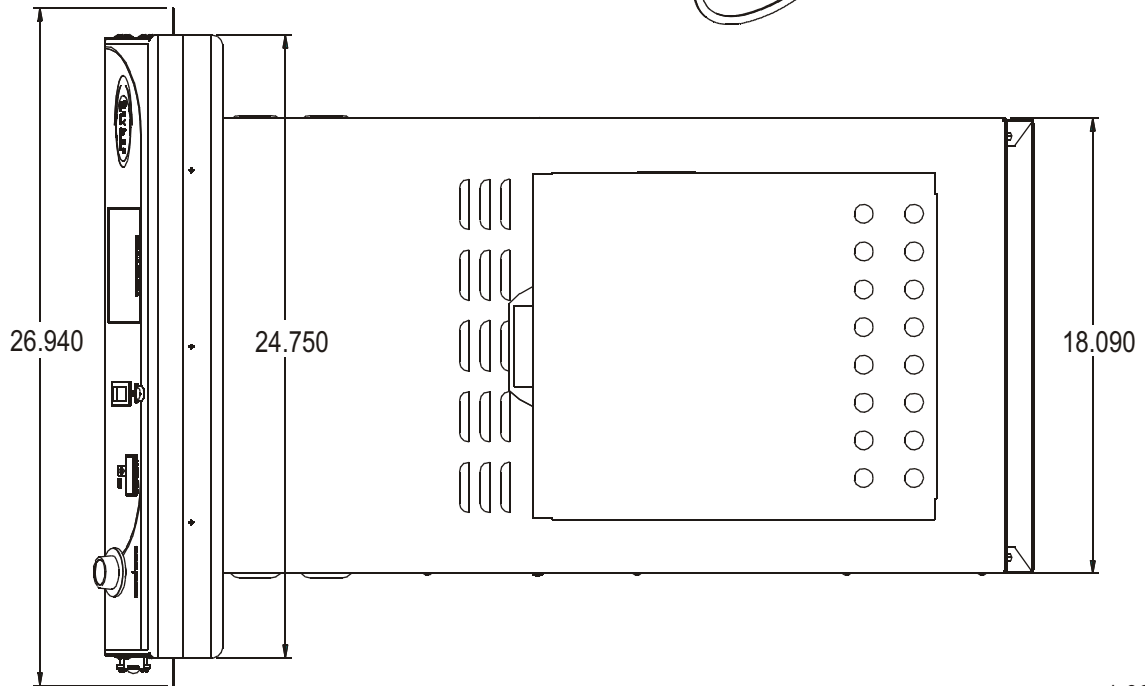
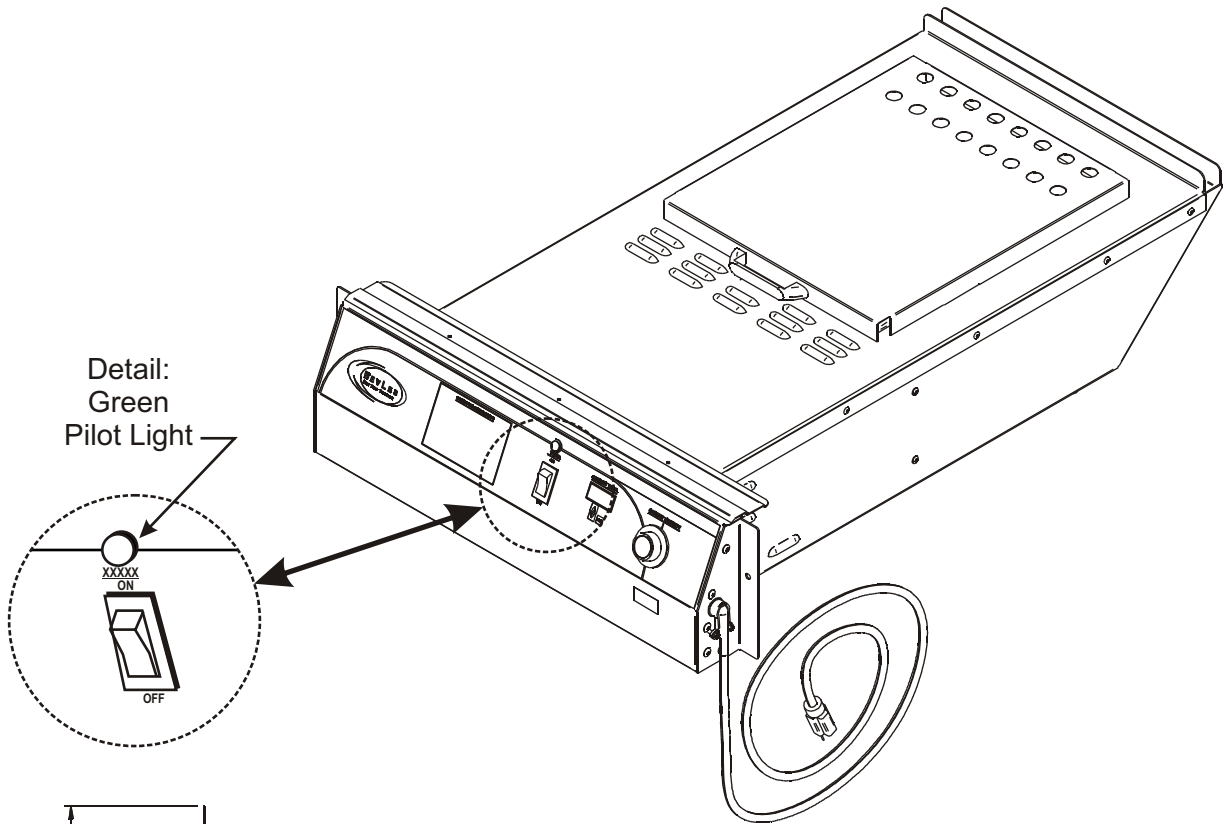

9. WIRING DIAGRAM

WIRING DIAGRAM Model: PICA70-32-A (ED)

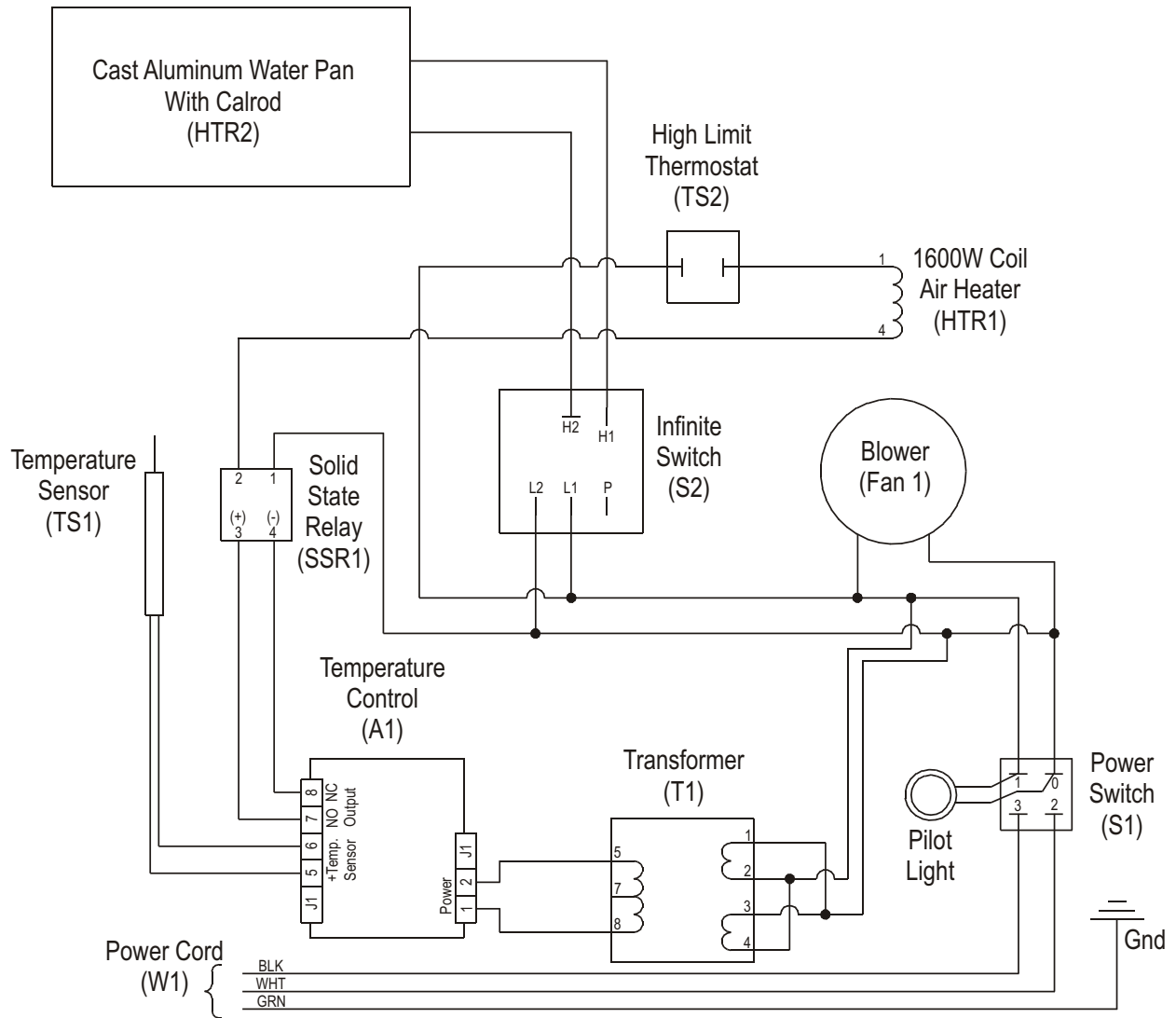

10. PARTS LIST w/EXPLODED VIEWS

Item	P/N	Description	Quan	Item	P/N	Description	Quan
1	1037200	Tape, Closed Cell	12 FT	38	770076	Rivet, 3/16 x 7/16, GR .125-.250	8
2	700428	Channel, Gasket	21	39	770084	Rivet, Soft, 5/16, 566 Pc/Lb	60
3	720670	Assembly, Bottom Module	1	40	770092	Bolt, Carriage 5/16-18 x 1 Z	2
4	720671	Pin Weldment	6	41	770152	Rivet, Soft, 1/4 x 1-3/4 Bzr Head	2
5	740281	Clip, Base	2	42	770156	Screw, Machine #1/4-20 x 3/4 .5 Lg	4
6	740336	Runner, Drip Pan Left	1	43	770188	Screw, Rd Hd Ph, 6-32 x 3/8, Z	6
7	740338	Runner, Drip Pan Right	1	44	770720	Washer, Flat, AN960C156	3
8	740348	Upright, 50.75" Long	4	45	780036	Caster 5" Hard Swivel w/Brake	2
9	740352	Back Vent	1	46	780040	Caster 5" Hard Swivel	2
10	740356	Back, Outer	1	47	780089	Manual, Proofer Cinnabon	1
11	741869	Base, Proofer	1	48	781285	Latch Spring	3
12	741871	Side, Outer Left	1	49	783012	Button, Upright	8
13	741873	Side, Outer Right	1	50	783040	Collar, Ø.375 x 1/4	2
14	741874	Hinge, Cabinet	6	51	783116	Knob, Thd Stud, 1/4-20 x .5	2
15	741875	Hinge, Door	6	52	784013	Shelf, Wire, 23" x 32"	11
16	742764	Cover, Valley, Heating Unit	2	53	790008	Bag, Poly, 1.5 Mil, 62 x 84	1
17	744225	Top, Proofer	1	54	790092	Carton, Hanger & Slide	1
18	744609	Support, Guide, Cord	1	55	791070	Carton, HSC	1
19	744816	Slide, Guide, Cord	1	56	792014	Skid, Pica Style	1
20	750086	Frame, Door, Bottom	6	57	8170700	Screw, 10-32 x 1/2, Type AB	60
21	750132	Hinge, Butt	6	58	8172100	Screw, Machine #10-32 x 1/2, S/S	18
22	750396	Spacer, Back Vent	2	59	8196700	Screw, Sm, #10 x 3/4, Type AB	12
23	750419	Latch	3	60	8203400	M/S Ft Hd Ph 1/4-20 x 5/8 Zn	12
24	750720	Pin, Latch	3	61	8208200	1/4-20 x .75 Tr Hd	4
25	750864	Bracket, Corner, Door	12	62	8402900	Nut, Hex, 6-32 SS	6
26	750972	Latch, Strike, Proofer	3	63	8417100	Nut, Hex, KEPS 10-32	18
27	751061	Retainer, Wiper Blade	3	64	8431500	Nut, Hex, KEPS 1/4-20	8
28	751091	Bracket, Top, Right, Header	1	65	8435000	Hex-Nut 5/16-18	16
29	751119	Bracket, Top, Left, Header	1	66	8501500	Washer, Lock, Int #6, Z	6
30	751121	Hanger, Slide Guide	22	67	8506200	Washer, Lock, Int, #10, Z	18
31	751272	Door Frame, Right Side	3	68	8506600	Washer, Flat, #10 S/S	26
32	751273	Door Frame, Left Side	3	69	8507500	Washer, Flat, 1/4, Zn (5/8 OD)	10
33	760055	Door, Polycarbonate	3	70	8507900	Washer, Lock, Int, 1/4, Z	12
34	760083	Label, Drip Pan, Bottom Mount	1	71	8509300	Washer, Flat, SAE, 5/16 SS	16
35	770037	Washer, Lock, Int, 5/16	16	72	8861000	Label, Serial Number	1
36	770052	Rivet, Ø3/16 x 1/2, .250 - .312 GR	4	73	8969400	Hole Plug 3/16 Black	6
37	770064	Bolt, Carriage 5/16-18 x .75 Z	14	74	8969500	Hole Plug 1/4 Black	18

***NOT SHOWN**

EXPLODED VIEW (1 of 3)

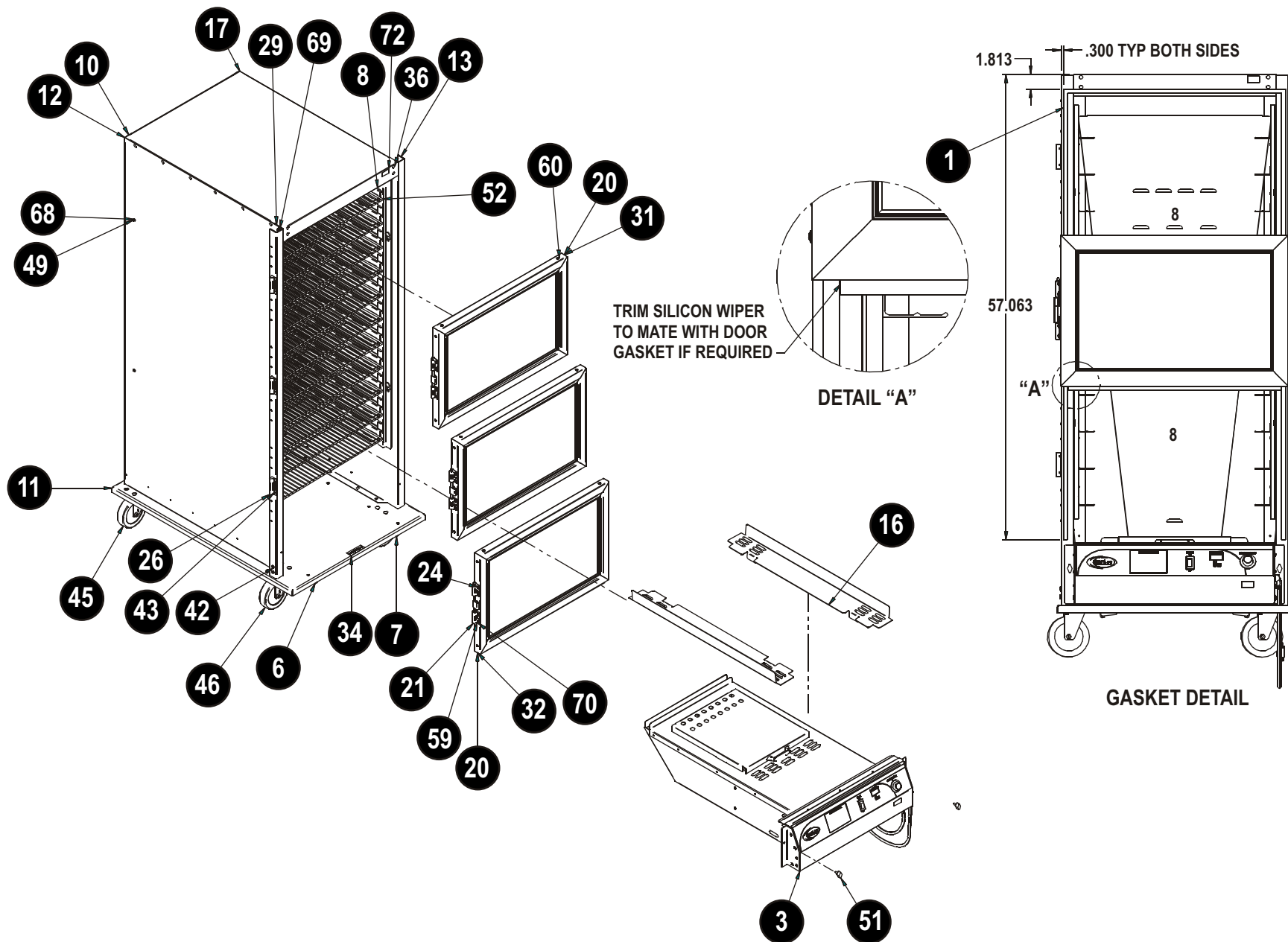

EXPLODED VIEW (2 of 3)

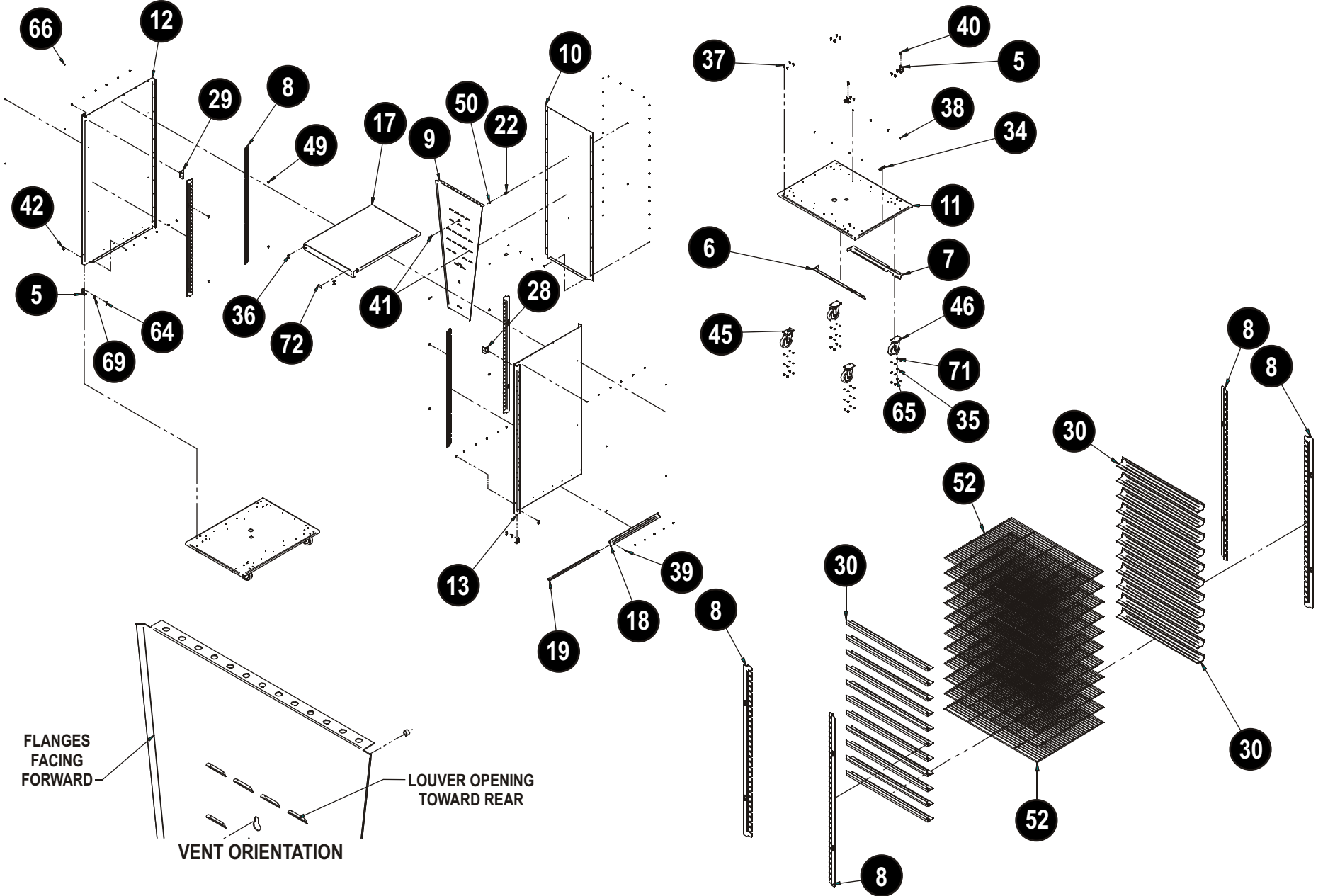

EXPLODED VIEW (3 of 3)

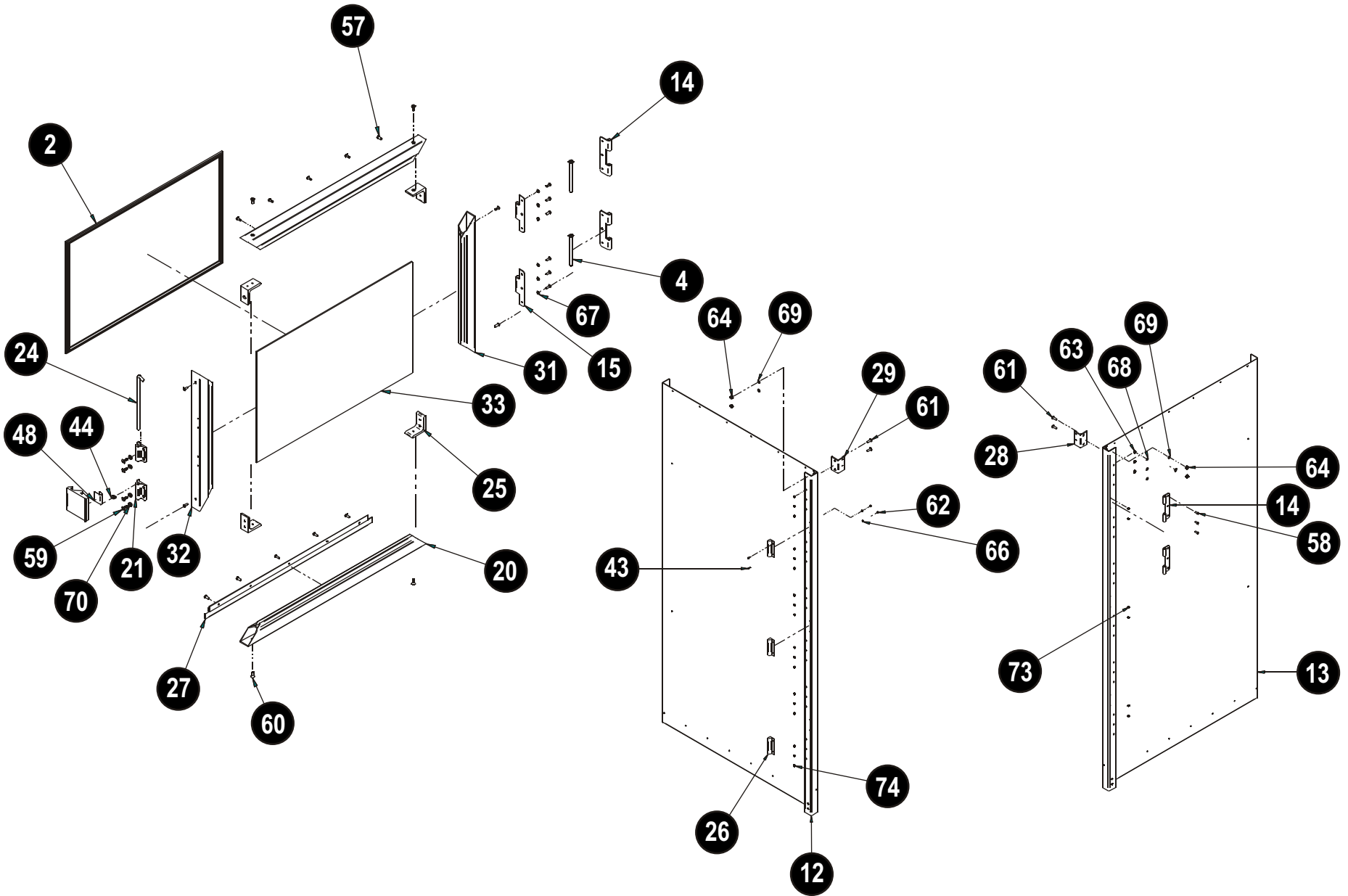

PARTS LIST - BOTTOM HEATING MODULE

Item	P/N	Description	Quan	Item	P/N	Description	Quan
1	1037100	Tape, Closed Cell, 1/8 x 1/2	7	38	782208	Thermostat	1
2	1101500	Box Connector, 90°	1	39	782226	Switch, Power, DPST	1
3	1509600	Light, Pilot Green	1	40	783015	Spacer, Nylon, #4	3
4*	1534200	Tie, Cable Nylon	7	41*	783024	Wire Nut, Red	2
5	21010402	Pipe, Drain	1	42*	784052	Wire Nut, Orange	4
6*	720414	Weldment, Air Duct, Motor	1	43*	784064	Wire Set PICA, #4001-A	1
7	720669	Assy, Water Pan Set (120V)	1	44	784124	Handle, Drawer Pull	1
	720674	Assy, Water Pan Set (240V)	1	45	784448	Transformer (120/240V)	1
8	740223	Bracket, Sensor	1	46*	784493	Terminal, Ring, #10	3
9*	740464	Splash Guard, Motor	1	47	784536	Cap, Plastic Snap-On	4
10	741870	Skin, Bottom	1	48	784538	Insert, Plastic, Snap-On	4
11	742733	Panel, Side, Right	1	49	784737	Controller, Temp	1
12	742734	Panel, Side, Left	1	50	8105800	Screw, Ph, 6-32 x 3/8, S/S	2
13	742735	Skin, Outer, Top	1	51	8108300	Screw, Pan Head 6-32 x 1/2	2
14	744292	Panel, Right Side, Front	1	52	8141400	8-32 x 1/2 MS	2
15	744293	Front Panel, Left Side	1	53	8159000	Screw, Tr Hd, 10-24 x 1/2, Z	2
16	744294	Cover, Drip, Water	1	54	8170700	Screw, 10-32 x 1/2, Type AB	7
17	744614	Panel, Front	1	55	8175200	M/s Tr Hd Ph 10-32 x 1/2 Zn	29
18	744869	Mount, Motor	1	56	8175400	Bolt, Carriage, 10-32 x 1/2, Zn	3
19	744870	Panel, Back	1	57	8175900	Screw, 10-32 x 1/2 Tr Hd, SS	24
20	744873	Cover, Wire	1	58	8353400	Rivet, Pop 3/16 Flushbreak	13
21	745578	Bracket, Heat Sink, Relay	1	59	8400100	Nut, Hex KEPS, #6-32	2
22	746639	Protector, Temp Control	1	60	8400700	Nut, Hex, 4-40, S/S	2
23	760040	Cover, Lexan, Water Pan	1	61	8402900	Nut, Hex, 6-32 SS	2
24	760224	Pad, Protective	2	62	8408300	#8-32 Hex Nut, KEPS, Ni	2
25	770021	Nut, Hex, 4-40, S/S, Small Pat	3	63	8417100	Nut, Hex, KEPS 10-32	3
26*	770332	Nut, Hex, Jam, 3/8-24, Z	1	64	8417600	Nut Hex 10-32 S/S	2
27	770706	Washer, Flat, Nylon, #4	3	65	8422400	#10-24 Hx Nut Grn	1
28	770719	Washer, Lock, Int, #4, S/S	5	66	8500900	Washer, Flat, #6, SS	4
29	770750	Washer, Flat, #4, S/S	5	67*	8502500	#8 Flat Washer, S/S	2
30	781010	Decal, Frnt Pnl, Btm Mod	1	68	8505300	Flat Washer, SAE #10	4
31	782020	Element, Coil, 1000W, 120V	1	69	8506200	Washer, Lock, Int, #10, Z	4
	784308	Element, Coil, 1000W, 240V	1	70	8506600	Washer, Flat, #10	3
32*	782069	Wire, Digital Thermometer	2	71*	8803500	Decal, Branch Circuit	1
33	782076	Power Cord 15A PICA 14-3 (120V)	1	72	8861000	Label, Serial Number	1
	701016	Power Cord (240V)	1	73	8967000	Bushing, Snap Heyco .5" I.D.	2
34	782088	Switch, Infinite (120V)	1	74	8967200	Bushing, Snap .5 Hole Nylon	2
	782224	Switch, Infinite (240V)	1	75	8980400	Clamp 1/4" Nylon	1
35	782092	Knob, Infinite Switch	1	76	8988100	Clamp, Cable, Nylon	1
36	782162	Relay, S-S	1				
37	782204	Blower, Motor, 120V, PRF	1				
	782205	Blower, Motor, 240v, PRF	1				

***NOT SHOWN**

EXPLODED VIEW - BOTTOM HEATING MODULE

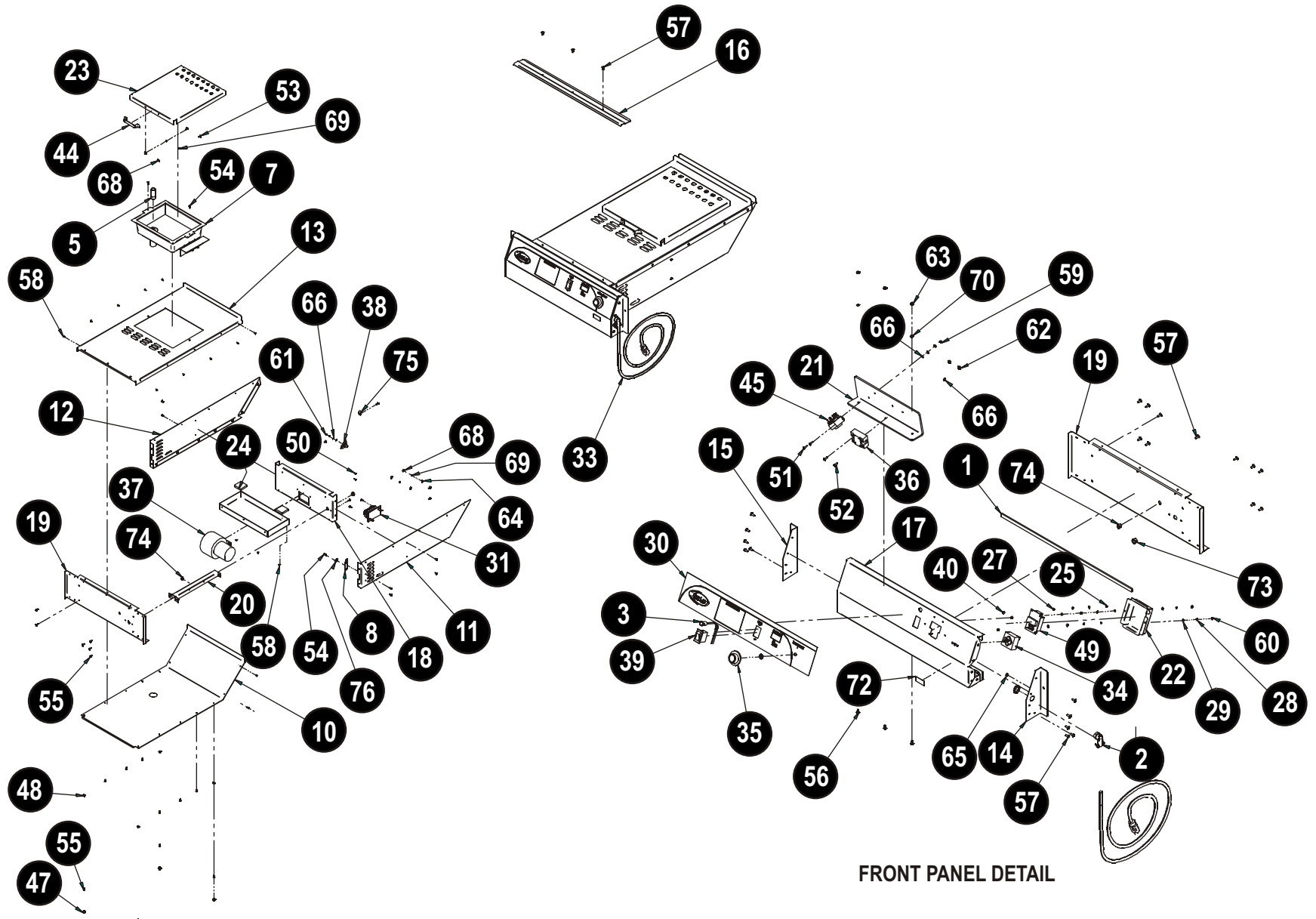

FRONT PANEL DETAIL



11. BEVLES COMPANY LIMITED WARRANTY

729 Third Avenue * Dallas, TX 75226

Phone: +1 (214) 421-7366 Fax: +1 (214) 565-0976

1. Bevles warrants to the original purchaser that on the date the equipment is shipped (sold), it will be free of defects in materials or workmanship. Bevles will, at it's discretion, repair or replace, during the warranty period printed below, any part that has a defect in material or workmanship that was present when the product shipped from Bevles, and which manifests itself during the warranty period under normal use and service.
 - Parts: Two* years from date of original shipment from the Bevles factory.
 - Labor: One** year from date of original shipment from the Bevles factory.

* Air Circulation Blower Assemblies (motors) and Power Switches shall be one year from date of original shipment.

Calrod "Air" Heating Elements shall be three years from date of original shipment.

** All electrical components 120 days from date of original shipment.
2. Bevles must be contacted, and pre-approval must be issued by the Bevles factory prior to any type of service being performed. Bevles assumes no responsibility for any charges that were not expressly authorized by the Bevles factory, or for any charges that exceed, in Bevles' sole judgement, normal and customary amounts.
3. Bevles will pay UPS Ground charges for any part that has a defect in material or workmanship that was present when the product shipped from Bevles, and which manifests itself during the **first year** of the warranty period under normal use and service. All warranty replacement parts will ship F.O.B. Bevles factory, Cheyenne, WY 82007.
4. This warranty shall be void in its entirety if any abuse of, misuse of, alteration/modification of or improper maintenance of original product occurs. If, at any time a claim is reported to Bevles, and the purchaser is delinquent in payment for the product, warranty will not apply.
5. Buyer's Remedies-If a Bevles product fails due to a defect in material or workmanship in conformity with the warranties in paragraph one, buyer shall notify Bevles of such failure within a reasonable time, but in no event beyond fifteen (15) days of such discovery of defect in material or workmanship. Bevles shall provide, in its sole discretion, either the repair or replacement of any defective or any non-conforming part. Bevles specifically disavows any other representation, warranty or liability relating to the continued use of the product.
6. Exclusion of consequential and incidental damages-In no event shall Bevles be liable for any incidental, special, indirect, or consequential damages, whether resulting from non-delivery or from the use, misuse, or inability to use the product, or from defects in the product, or from Bevles' own negligence or other tort. This exclusion applies regardless of whether such damages are sought for breach of warranty, breach of contract, negligence, or strict liability in tort or under any other legal theory.
7. Disclaimer of warranties-The warranties contained in paragraph one above are the exclusive warranties given by Bevles and supersede any prior, contrary, or additional representations, whether oral or written. Bevles hereby disclaims and excludes all other warranties-whether expressed, implied, or statutory-including any warranty of merchantability, any warranty of fitness for a particular purpose, and any implied warranties otherwise arising from course of dealing or usage of trade.

1/05



Innovative Foodservice Equipment
Designed for Performance, Service and Value

Phone: +1 (214) 421-7366
Fax: +1 (214) 565-0976
Toll Free: +1 (800) 441-1601
Website: www.BevLes.com
E-mail: sales@BevLes.com

BevLes
729 Third Avenue
Dallas, TX 75226