

OWNER'S MANUAL

HANDWASH ACCESSORIES

This owner's manual applies to the following models:

HWAPR – Handwash Accessory with Paper Towel Roll Holder

HWATD – Handwash Accessory with Paper Towel Dispenser

For use with **Camtainer** models: 250LCD, 500LCD

Ultra **Camtainer** models: UC250, UC500

Congratulations on the purchase of your new Handwash Accessories. This Owner's Manual provides you with a step by step guide to assemble and maintain your Handwash Accessories. If you have any further questions, please do not hesitate to contact us. Visit our website at www.cambro.com or call our Customer Service Dept. (800) 833-3003

StaySafe
StoreSafe



Camtainer with HWAPR



Ultra Camtainer with HWATD

I – Product View

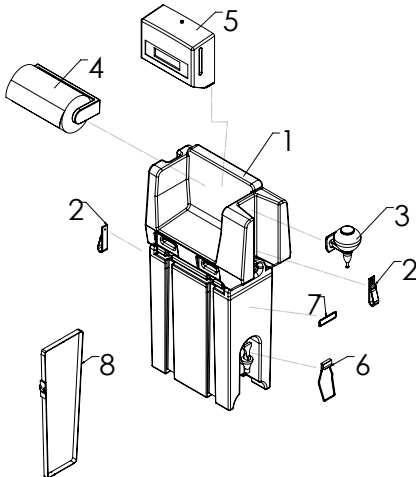

1. Handwash Unit (body)
2. Quick Release Straps
3. Soap Dispenser
4. Paper Towel Roll Holder (HWAPR)
5. Folded Paper Towel Dispenser (HWATD)
6. Easy Serve Dispenser Lever
7. Handwashing Only Label (sheet of 4 labels)
8. Quick Release Strap (earlier style—units before 01/05)

*Flat towels and paper towels not included.

NSF (Camtainers and Ultra Camtainers only)



CAMBRO
TRUSTED FOR GENERATIONS™

www.cambro.com

II – Assembly and Use

1. Fill the Camtainer with hot water (HACCP guidelines for hand washing is 105°F (40,6°C) but check your local health department for temperature guidelines.)
2. Place handwash unit on top of container, run straps under the handles and through the slots at the base of the handwash unit.
3. Tighten straps so that the handwash unit and the container are snugly mounted together.
4. Install paper towels in plastic dispenser or attach paper towel roll.
5. Fill soap dispenser bottle and twist up onto the mount arm bracket.
6. Place "Handwashing Only" label on container just above the faucet in the smooth window area provided to clearly identify designated use.
7. Place the dispensing lever onto the faucet lever with the curve of the lever facing outward, towards you so that when you push forward on the lever, water is released through the faucet.

ACCESSORY RECOMMENDATIONS

For extra stability on table or counter edge, Riser Accessory (R500LCD) is recommended for use with the handwash accessory and Ultra Camtainers UC250 and UC500. (Not required for use with Camtainers 250LCD and 500LCD.)

Pail with Bail (PWB22) is recommended to catch and contain used water. Place directly under faucet. Captures a 5½ gallon (20,8 L) capacity.

III – Care and Maintenance

1. Wash unit after each use with warm soapy water and a soft cloth.
2. Rinse out the soap container with warm water. The dispensing pin of the bottle assembly should be cleaned daily with a clean wet cloth.
3. Never use wire brushes, abrasive cleaners, strong detergents or steel wool when cleaning any of the unit components.
4. Always wipe dry the metal paper towel dispenser after cleaning to prevent rust.
5. If any staining occurs on the body section, use any standard de-stainer such as: "Dip It," Wyandotte's "Salute" or American Dietary Product's "Ware Dip."

IV – Replacement Parts

Please visit www.cambro.com for a complete list of replacement parts. The model number of the handwash accessory is required to determine the correct replacement part.

TO ORDER REPLACEMENT PARTS:

- Call Cambro Customer Service at (800) 833 3003 or
- Fax your order to (714) 842 3430 or
- Call your local Cambro Representative or Distributor

V – Cambro Warranty and Product Liability

Cambro warrants to the original buyer that if a product proves defective:

1. Within 1 year from the date of manufacture, Cambro will replace the product free of charge; or,
2. After 1 year and up to 2 years from the date of manufacture, Cambro will grant a credit of ⅓ off replacement product; or,
3. After 2 years and up to 3 years from the date of manufacture, Cambro will grant a credit of ⅓ of the original price towards a replacement product.

VI – Proper Hand Washing Guidelines Per FDA

When should food employees wash their hands?

They should do this immediately after engaging in activities that contaminate the hands and:

- When entering a food preparation area;
- Before putting on clean, single-use gloves for working with food and between glove changes;
- Before engaging in food preparation;
- Before handling clean equipment and serving utensils;
- When changing tasks and switching between handling raw foods and working with Ready-to-Eat foods;
- After handling soiled dishes, equipment, or utensils;
- After touching bare human body parts, for example, parts other than clean hands and clean, exposed portions of arms;
- After using the toilet;
- After coughing, sneezing, blowing the nose, using tobacco, eating, or drinking; and
- After caring for or handling services animals or aquatic animals such as molluscan shellfish or crustacea in display tanks.

What handwashing steps do food employees need to follow?

Clean hands and exposed portions of arms, including surrogate prosthetic devices for hands and arms, for at least 20 seconds by the following method:

1. Rinse under clean, warm running water;
2. Apply soap and rub all surfaces of the hands and fingers together vigorously with friction for at least 10 to 15 seconds, giving particular attention to the area under the fingernails, between the fingers/fingertips, and surfaces of the hands, arms, and surrogate prosthetic devices;
3. Rinse thoroughly with clean, warm running water; and
4. Thoroughly dry the hands and exposed portions of arms with single-use paper toweling, a heated-air hand-drying device, or a clean, unused towel from a continuous towel system that supplies the user with a clean towel.

Avoid recontamination of hands and arms by using a clean barrier, such as a paper towel, when turning off hand sink faucets or touching the handle of a restroom door.