



# capkold®

## OPERATOR MANUAL

IMPORTANT INFORMATION, KEEP FOR OPERATOR

888-994-7636, fax 888-864-7636  
unifiedbrands.net

THIS MANUAL MUST BE RETAINED FOR FUTURE REFERENCE. READ, UNDERSTAND AND FOLLOW THE INSTRUCTIONS AND WARNINGS CONTAINED IN THIS MANUAL.

**FOR YOUR SAFETY** Do not store or use gasoline or other flammable vapors and liquids in the vicinity of this or any other appliance.

**WARNING** Improper installation, adjustment, alteration, service or maintenance can cause property damage, injury or death. Read the installation, operating and maintenance instructions thoroughly before installing or servicing this equipment.

**NOTIFY CARRIER OF DAMAGE AT ONCE** It is the responsibility of the consignee to inspect the container upon receipt of same and to determine the possibility of any damage, including concealed damage. CapKold suggests that if you are suspicious of damage to make a notation on the delivery receipt. It will be the responsibility of the consignee to file a claim with the carrier. We recommend that you do so at once.

Manufacture Service/Questions 888-994-7636.

## SAFETY

The CapKold Tumble Chiller was designed with the safety of the operator and maintenance personnel in mind, as well as the safe functioning of the machine. Continuous safety of the operators and plant personnel can only be maintained through cautious and competent operation as well as regular and complete maintenance.

Safety precautions and warnings are noted in this manual as their need occurs. Please make note of them and pay special attention.

**WARNING: THIS TELLS THE OPERATOR THAT EXTREME DANGER EXISTS AND EXPLAINS THE NECESSARY AND SAFE ACTIONS TO PROTECT HIMSELF AND OTHERS.**

**CAUTION: THIS TELLS THE OPERATOR THAT EQUIPMENT MAY BE DAMAGED UNLESS CERTAIN ACTIONS ARE TAKEN.**

**NOTE: CALLS ATTENTION TO AN IMPORTANT CONDITION OR EVENT.**

This manual provides information for:

## TUMBLE CHILLER MODEL CKTC-320

The purpose of this manual is to provide information that will aid in the installation, operation, maintenance and repair of a CapKold Tumble Chiller. This manual should be read completely before installing and/or operating this machine. While every effort is made to provide accurate and up-to-date information, CapKold reserves the right to change the specifications herein without notice. CapKold also reserves the right to make changes and improve this product without obligating itself to install any such changes or improvements in products previously manufactured. The illustrations and descriptions herein are general in nature and may not include all standard equipment or may include optional equipment.

The only applicable warranty is our standard written warranty, and there is no other warranty, written or implied.

## INTRODUCTION

The information in this section will aid in the operation of the CapKold Tumble Chiller and must be read completely before operating the unit.

The CapKold Model CKTC-320 front loading batch tumble chiller is designed to rapidly chill food packaged in flexible plastic casings by gently massaging the casings in a water bath. The touch screen control provides easy operator interface. The chilled water source provided by the customer (Ice Builder) is pumped through a heat exchanger which includes an automatic back flush to maintain optimal heat transfer efficiency. A recycle tank is available to reuse chilled water after each cycle saving water and energy.

## INSTALLATION

The following instructions will aid in a quick and correct installation of your new Tumble Chiller.

**Receiving:** Immediately upon receipt, the unit should be inspected for any damage that may have occurred during shipping. Any damage should be reported to the driver and the freight company immediately.

**Tools Required:** Open end wrenches and flat blade screwdriver.

**Lifting and Handling:** The approximate weight of the tumble chiller is 2500 lbs. The machine may be lifted by fork truck from the front of the machine.

**Setting Machine:** Choose a clean level area protected from weather conditions, moisture, heat, and any foreign debris above or around the unit. Insure that adequate clearance exists between machine and other machines and obstructions. A minimum of 3 feet should be maintained.

**Final Machine Leveling:** Machine must be level from front to back as well as side to side. If not level, adjust leveling legs maintaining a minimum of 6 inch clearance from floor to bottom of machine.

**Optional Recycle Tank:** The approximate weight of the recycle tank is 700 lbs. The tank may be lifted by fork truck from the front of the machine. Align the 4 pins with the holes on the base machine and lower in place. Connect hoses to base machine.

**Panels:** Install all panels using the truss screws provided.

## UTILITY CONNECTIONS

Electrical: Installation and grounding must conform with local codes, or in absence of local codes, with the National Electrical Code.

### Branch Circuit Protection:

Machine Voltage	Wire Size *	Breaker Size
208 VAC	12	15 AMP, 3 Pole
240 VAC	12	15 AMP, 3 Pole
480 VAC	12	15 AMP, 3 Pole

\* Wire size based on THW or MTW wire. If run exceeds 300 ft, use next larger size.

\* Power supply must connect on the side or bottom of the control. Water damage will occur if connected at any other location.

**Air:** The air supply is connected to a 1/4" pipe at the rear left side of the machine. The air supply must be 90-100 PSIG. A shut off valve should be provided at or near the connection.

**Mains Water:** The mains water supply is connected to a 1 1/2" pipe located at the rear right side of the machine (see Figure 2). A shut off valve should be provided at or near the connection.

**Chilled Water:** The chilled water supply is connected to a 1 1/2" pipe located at the rear right side of the machine (see Figure 2). The chilled water return is connected to a 1 1/2" pipe located above the chilled water supply connection. A shut off valve should be provided at or near the connections.

**Steam:** The steam supply is connected to a 1-1/4" pipe located at the rear right side of the machine (see Figure 2). A shut off valve should be provided at or near the connection.

**Waste Drain:** The waste drain is connected to a 2" pipe located at the rear bottom right side of the machine (see Figure 2).

## EQUIPMENT DESCRIPTION

The CapKold Model CKTC-320 batch tumble chiller will chill up to 300 gallons of bagged product. The machine is stainless steel construction throughout with a perforated stainless steel basket. An inclined loading chute allows continuous loading of product while the basket is in motion.

The touch screen control provides easy operator interface, with simple custom programming.

The drive system consists of a variable speed 1 HP motor and a selectable reversing function for improved tumble action while chilling and a manual jog for distribution while unloading. Power transmission to the cylinder is performed by a direct drive gear box to achieve smooth operation.

The door is locked and sealed manually and may not be opened while the tumble chiller is operating. This interlock also requires that the door be shut and sealed prior to starting.

Basket Size	58" Diameter x 46" Depth
Basket Volume	70.3 Cubic Ft.
Basket Material	14 Gauge 304 Stainless Steel
Basket Rib Size	Four 4 1/4" High Triangular Ribs
Basket Angle	10 Degrees
Door Opening Size	30" Diameter
Door Chute Opening Size	12" Diameter
Drive Motor	1 HP
Centrifugal Pump Motor	1 1/2 HP
Basket RPM	2-8 RPM
Water Inlet Size	1 1/2"
Chilled Water Inlet Size	1-1/2"

Steam Inlet Size	1 1/4"
Drain Size	2"
Overflow/Vent Size	1 1/2"
Air Supply	1/4", 90-100 PSI
Shipping Weight	2,500 LBS
Shipping Dimensions:	
Tumble Chiller	64" Wide x 96" Deep x 80" High
Optional Recycle Tank	64" Wide x 83" Deep x 24" High

## STANDARD FEATURES AND COMPONENT DETAILS

**Gear Motor Drive with Inverter:** The machine includes a 1 HP single motor drive and AC variable frequency inverter. This arrangement provides precise speed control of the inner basket between 2 and 8 rpm's through a gearbox motor mounted directly to the basket's main shaft. The basket rotation options include one way, oscillate and gentle. The energy efficient motor is rated for continuous duty. The inverter is safely mounted in the electrical cabinet.

**Front Door:** The front door includes an inclined loading chute to allow continuous loading of product while the basket is in motion. Pneumatics are used to seal/lock and unlock the door.

**Heat Exchanger:** The chilled water source is pumped through a high heat transfer coefficient plate heat exchanger.

**Leveling System:** A leveling system consisting of four adjustable legs. No special foundation is required other than a floor with the capacity to hold the static weight load of the machine, water, and products contained within.

**Bearing Design:** A shaft mounted flange bearing design and integrated bearing/motor/gear box supports the cantilevered load of the inner basket. The front and rear bearings are sealed ball bearings and do not require grease.

**Seal Housing:** A housing containing a spring loaded ceramic seal keeps water and chemicals contained in the machines shell from leaking out, while allowing the machine's main basket shaft to rotate freely. The ceramic seal is lubricated with water and the basket will not rotate without the centrifugal pump turned on or without the mains fill open.

**Mains Water Inlet Valve:** The water inlet valve is pneumatically operated, 1 1/2" butterfly type, and is closed by spring pressure.

**Chilled Water Inlet Valve:** The water inlet valve is pneumatically operated, 1 1/2" butterfly type, and is closed by spring pressure.

**Steam Inlet Valve:** The steam inlet valve is pneumatically operated, 1-1/4" butterfly type, and is closed by spring pressure. The standard machine is outfitted with one valve for direct steam injection into the bottom of the shell through a diffuser nozzle. Steaming does not occur until the water level has been satisfied. If no steam is available, hot water supply can be used and must be programmed in the formula.

**Drain Valve:** A pneumatically operated, 2" butterfly type valve mounted below the outside shell allows for rapid gravity draining of waste water.

**Automatic Back Flush:** An automatic back flush of the heat exchanger will back flush build up of foreign matter which has entered the heat exchanger in order to maintain optimal heat transfer between chilled water and product.

**In-Line Filter:** An easily accessible in-line filter provides protection for the pre piped centrifugal pump in the event a plastic bag breaks open.

**Touch Screen Controller:** A PLC-based, Operator Interface Terminal with a graphical touch screen provides the formula control for the machine. It provides a storage capacity for up to 99 formulas, up to 99 events (steps) per formula, and 99 product codes. Functions include step time, rotation intervals and speed, water addition and draining, temperature control, chemical and steam injection, door operation and safety interlocks for the protection of the operator and machine. The OIT connects to the machine's PLC allowing multiple input/output capability, while providing the operator and maintenance personnel with an easy to program control system.

## OPTIONAL EQUIPMENT

**Recycle Tank:** An insulated recycle tank with high and low level sensors and 1" water valves to direct water to the tank. The tank also includes a 1 1/2" drain valve which drains the water into the shell.

**Control Right Side/Left Hinged Door:** A control mounted on the right side of the machine with a left hinged door is available.

**Prison Package:** The prison package includes tamper proof hardware per the American Correctional Food Service Association Guidelines.

## MACHINE SPECIFICATION

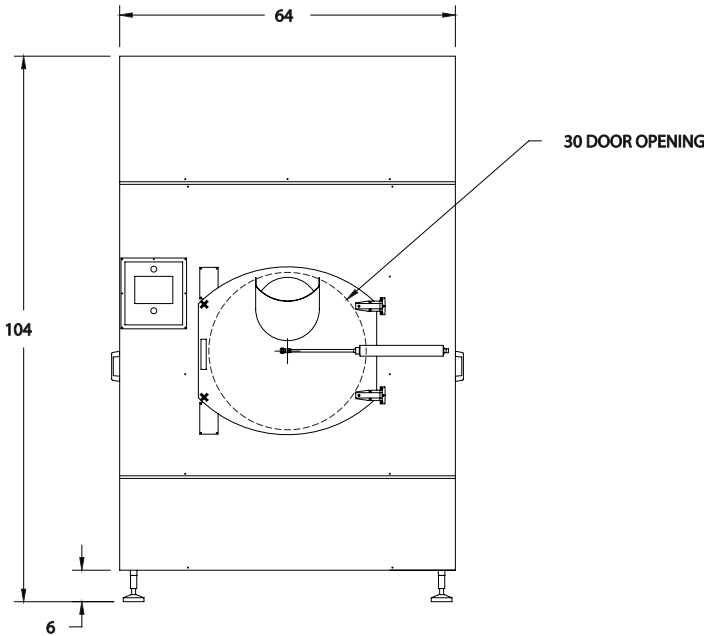

Front Elevation **Figure 1**

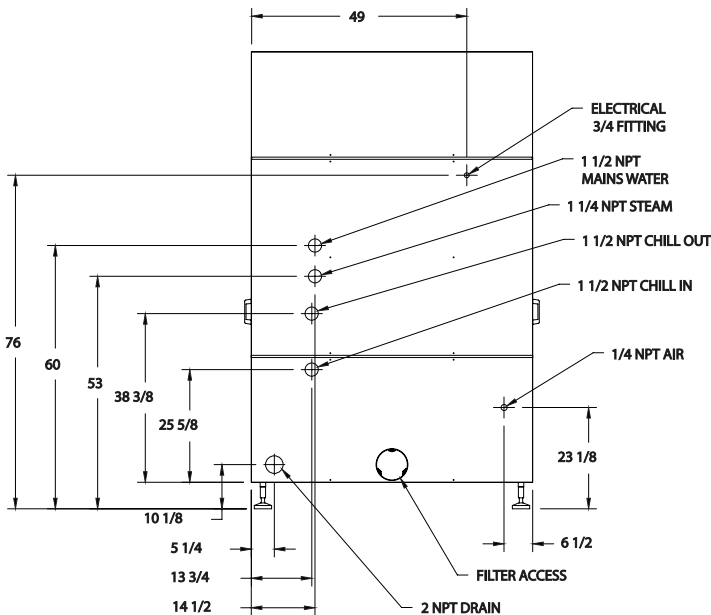

Rear Elevation **Figure 2**

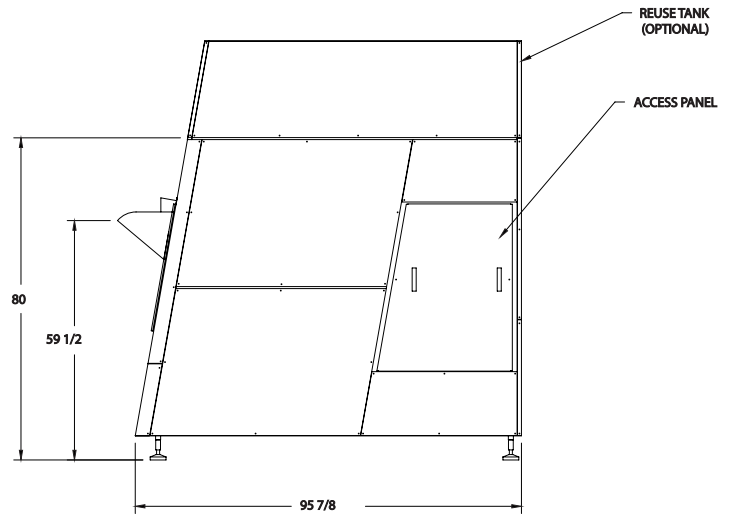

Right Elevation **Figure 3**

## OPERATIONS

### SAFETY PRECAUTIONS AND INSTRUCTIONS

The following instructions will aid in a quick and correct installation for your new CapKold Tumble Chiller.

**WARNING: TO AVOID SERIOUS BODILY INJURY OR EQUIPMENT DAMAGE OPERATE EQUIPMENT IN STRICT ACCORDANCE WITH MANUFACTURER'S OPERATING INSTRUCTIONS.**

DO NOT operate machine unless all original safeties are installed and in proper working order including door interlocks, access panels and signal devices.

DO NOT exceed designed load capacity of machine (100 gallons to 300 gallons of bagged product).

DO NOT process material containing flammable or volatile cleaning agents into machine.

DISCONNECT power to machine when not in use to limit risk of unauthorized operation.

IN CASE OF EMERGENCY: Push the red "EMERGENCY STOP" switch located on the operator station, the control circuit will be disabled, turning off the machine.

ALWAYS DISCONNECT AND LOCKOUT ELECTRICAL POWER BEFORE:

- Performing any type of maintenance, repair, or inspection.
- Entering the basket or area beneath the tub.
- Removing any safety covers, guards, or access panels.

NEVER REMOVE, DISCONNECT, OR ALTER MACHINE SAFETY FEATURES, MECHANICAL INTERLOCKS, ELECTRICAL INTERLOCKS, OR SIGNAL DEVICES.

DO NOT OPERATE, REPAIR, MAINTAIN, OR ADJUST THIS EQUIPMENT:

- Without reading and understanding this manual.
- Unless these precautions are understood.
- If under the influence of drugs or alcohol.
- If taking medication which distorts judgment or causes drowsiness.
- If advised by doctor or other medical personnel not to operate heavy machinery.
- If, at any time, you doubt your own ability to safely operate this machinery.

IF THERE ARE ANY QUESTIONS CONCERNING SAFETY PRECAUTIONS OF MACHINE OR ITS OPERATION, CONTACT UNIFIED BRANDS AT 888-994-7636.

## PREOPERATIONAL CHECKS

- Verify air supply pressure is in accordance with nameplate data. Open air supply valve slowly to prevent injury to personnel.
- Ensure the main air pressure regulator is set at 80 psi.
- Verify steam supply pressure, then open supply valve slowly to prevent shock to steam lines. If not using steam, check temperature of hot water.
- Verify water supply pressure, then check individual pressures of mains and chilled water. Open all water supply valves slowly.
- Open the control panel and inspect for cleanliness – panel must be free of dirt and debris before energizing. Clean panel interior with vacuum cleaner and a dry or slightly damp cloth only. Inspect control panel door seal and replace if worn or damaged. Check electrical connections for tightness.
- Close all electrical panel doors and ensure all latches are properly fastened.
- Verify that proper voltage and current are available at disconnect in accordance with nameplate data. Use voltage meter to verify voltage.

### CAUTION

- Centrifugal Pump - Do not run pump dry as permanent damage to the mechanical seal will result.
- Important: Proper Rotation – Power supply should be applied momentarily to the pump at first and the direction of rotation checked. When viewing the front of the pump, the motor shaft (impeller) should be rotating counterclockwise. If it is not, disconnect power and re-check wiring to motor. To change rotation on three-phase models, interchange any two incoming line (power) leads.
- Do not rotate basket without water connected as permanent damage to the mechanical seal will result.

## MACHINE CONTROLS

Panel Disconnect: An electrical disconnect is provided on the exterior of the rear electrical panel. This switch shall be in the down or “OFF” position when the tumble chiller is not in use. The disconnect has provisions for being locked in the “OFF” position. This feature must be used during machine maintenance. The rear panel door is mechanically interlocked with the disconnect switch in order to prevent the door from being opened while the disconnect is in the up or “ON” position.

**WARNING: TO PREVENT ELECTRIC SHOCK ENSURE THERE IS NO VOLTAGE AVAILABLE TO INPUT LUGS OF PANEL DISCONNECT SWITCH PRIOR TO SERVICE IN PANEL.**

Control Panel: See Figure 5 for the control panel.



Control Panel Figure 5

Emergency Stop: The Emergency Stop is located on the bottom center of the panel and is easily identified by its large red mushroom shaped operator. Pushing the Emergency Stop push button at any time will stop machine action. The tumble chiller has been designed to fail safe. This means that when power is lost (due to power outage, etc.) the door will remain sealed and locked.

The Emergency Stop switch is a push-pull type. To reset the Emergency Stop, it must be pulled out.

## CHILLER OPERATION

**NOTE: ENSURE ALL PREOPERATIONAL CHECKS HAVE BEEN SATISFACTORILY COMPLETED PRIOR TO PERFORMING STARTUP.**

**CAUTION: PUSH THE RED EMERGENCY STOP SWITCH IF ANY UNSAFE OR UNEXPECTED CONDITION APPEARS TO EXIST.**

### 1. Start of Chill Cycle

- Close door, LOCK DOOR button appears.
- Press LOCK DOOR. (Door must be firmly pressed closed prior to and after pressing the lock door button)
- UNLOCK DOOR button appears and can be unlocked provided the basket is empty.
- Press “SELECT FORMULA” area on screen, list of cycle formulas appear.



- Select the desired Chill cycle formula by highlighting and then pressing LOAD.
- After pressing the LOAD button “FORMUAL LOADED SUCESSFUL” will appear, then press the CLOSE button. You will automatically be taken back to the Main display.

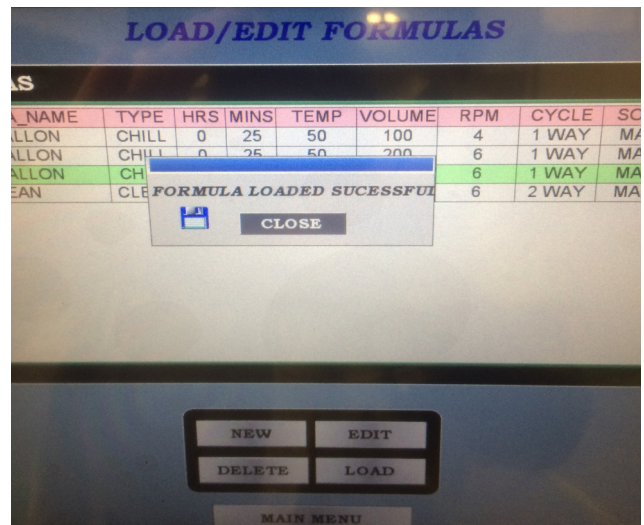

- Press CYCLE START.
- Drum will fill with water, the centrifugal pump and the basket will rotate when the low water level is reached and the chilled water valve will open.
- Operator will be alerted “Ready to Load Bags” and the LOAD BAGS button will appear.



- The Load bags button when pressed will stop the alarm. After the bags are loaded press the ok button to start the batch timer.
  - The chill cycle will run for the programmed time, then the operator will be alerted to “CHECK BAG TEMPERATURE”.
  - Press CYCLE PAUSE to stop basket rotation and centrifugal pump to remove a bag to sample the temperature.
  - If the temperature of the product is below 40 deg F, then press END CYCLE. If the temperature of the product is above 40 deg F, then press START and this will add 15 minutes to the chill cycle. The chill cycle will continue until the operator is alerted to “CHECK BAG TEMPERATURE” and the temperature verification process is repeated.
  - After the temperature of the product is below 40 deg F and the END CYCLE button is pressed, the basket will stop rotation, the chilled water valve will close, and the centrifugal pump will stop.

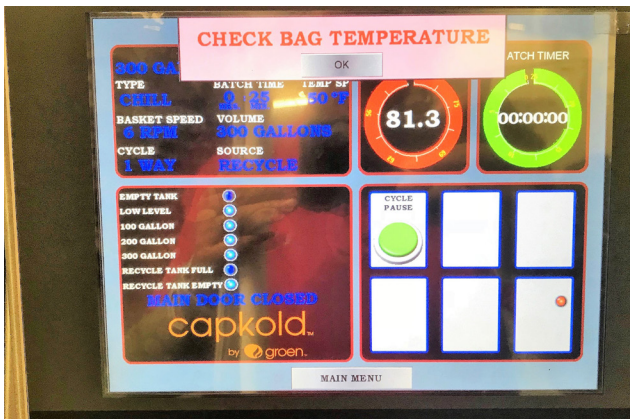

- Press the appropriate button DRAIN TO TANK or DRAIN TO WASTE.



- When the water has drained completely, the operator is alerted to “Remove Bags”.
- Press UNLOCK DOOR. (EMPTY TANK LIGHT MUST BE ON TO OPEN THE DOOR)
- Unload bags and press JOG button as required to redistribute the bags.

## 2. Start of Clean Cycle

- Close door, LOCK DOOR button appears.
- Press LOCK DOOR. (Door must be firmly pressed closed prior to and after pressing the lock door button)
- UNLOCK DOOR button appears and can be unlocked provided the basket is empty.
- Press “SELECT FORMULA” area on screen, list of cycle formulas appear.



- Select the desired Clean cycle formula by highlighting and then pressing LOAD.
- After pressing the LOAD button “FORMUAL LOADED SUCESSFUL” will appear, then press the CLOSE button. You will automatically be taken back to the Main display.



- Press START CYCLE.
- Drum will fill with water, the centrifugal pump and the basket will rotate when the low water level is reached and the steam valve will open.
- The automatic sanitizer injection will start or a sanitizer can be added manually through the chute opening.
- The drum will continue filling to programmed temperature and level, then the timer will start.
- When the timer reaches 00:00, the basket and the centrifugal pump will stop. The transfer valves will open and the water will be transferred to the tank.
- When the tank is full, the timer will start.
- When the timer reaches 00:00, the tank will drain and the operator will be alerted to “Clean Out In-Line Filter”.
- Press END CYCLE.

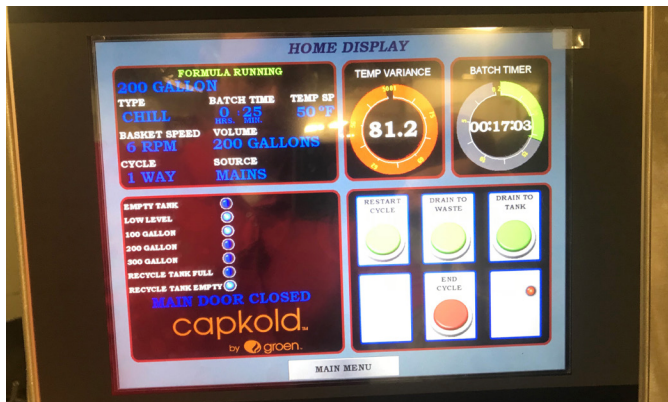

- Press UNLOCK DOOR. (Empty tank light must be on to open the door)
- Repeat with a Rinse Cycle if chemicals were used.

## SHUTDOWN

The disconnect switch should only be used to power off the system for service or an emergency circumstance.

Improper shutdown results in possible file corruption in the system. Improper shutdown may consist of:

- Windows is stopped before proper shutdown is performed
- Power outage

### SHUTDOWN PROCESS

1. The system can be shut down correctly by logging into the HMI as: UserID: ENG, Password: 100.
2. Navigate to the Settings display.
3. Select Shutdown HMI Application.
4. Once the Windows desktop is shown, go to the Windows start menu.
5. Select Shutdown.

Once Windows is shut down correctly, it is safe to turn off the disconnect.

### POWER OUTAGE RECOVERY

1. Shutdown the HMI app using step 1 above. Do **NOT** shut down Windows.
2. Once on the desktop, locate the folder and files: C:\Drive\CDRIVE FOLDERS\HMI PROGRAM etc.
3. Verify the Backup exists (if not, notify CapKold Service department).
4. Delete the file **without** the -ENG BCKUP file name.
5. Copy the file with the -ENG BCKUP file name and paste in the same location. It will be indicated by having -COPY after the file name.
6. Rename the file **without** the words -ENG BACKUP-COPY, naming it as the file that was previously deleted.
7. Restart the HMI.

## TROUBLESHOOTING

Fault	Probable Cause
Door will not lock	Check manual door tightening knobs
	Shim door hinges as required
Door will not unlock	Shim door hinges as required
	Empty tank light must be on
Door will not seal	Inspect and replace seal
	Check manual door tightening knobs
	Shim door hinge and door locks as required
Product will not chill properly	Clean strainer
	Perform automatic back flush cycle on heat exchanger
	Check temperature probe
	Check chilled water temperature and flow (Ice Builder)
Pump motor O.L.	Clean strainer
	Perform automatic back flush cycle on heat exchanger
Drive Motor Thermal O.L.	Drum overloaded
Emergency Stop Switch Pressed	After investigation, pull out on emergency stop switch
Water Level Too High	Check float level
Formula Not Loaded	No valid product/item selected
Water valves not opening	Check air pressure
	Check air lines for leaks

**CAUTION: TO AVOID PERSONAL INJURY DISCONNECT ALL POWER BEFORE SERVICING.**

## MAINTENANCE AND REPAIR

### SCHEDULED MAINTENANCE

#### Daily:

- Empty pneumatic system water separator bowl.
- Check water and air lines for leakage.
- Check for abnormal noises.
- Check water leaking from seal housing (1/4 plastic drain line in seal housing).
- Empty inline filter (ensure the drum is empty).

#### Monthly:

- Check and fill the oil level in the gear box to the fill plug. Use manufacturer recommend lubrication.

### SENSOR ADJUSTMENT

#### Door Open/Close Sensor:

- Adjust door closed sensor so there is a 1/16 to 1/8 inch gap between the sensor and the front panel when door is closed.

### Door Lock/Seal Sensor:

- Remove cover plates to access door lock sensor.
- Close door and press LOCK DOOR button.
- The red LED light should be illuminated with the door in the lock position.
- To adjust sensor, loosen clamp holding the sensor on the air cylinder and move the sensor up/down until red LED light illuminates and tighten clamp.
- Check functionality by cycling UNLOCK DOOR and LOCK DOOR button and readjust as required.
- Install covers.

### WATER AND STEAM VALVES

#### Removal of Actuator from Water Valve Body:

Apply 80 psi air pressure to the valve actuator. This will retract the valve plunger from the seat, relieving the pressure on the actuator. Loosen the retaining nut and remove the actuator assembly from the body. There is a gasket located under the nut. This gasket must be properly seated when reassembling the valve or leakage will occur. The steam valve actuator does not require air to disassemble as its spring is much weaker.

**Valve Assembly:** See Figure 6

1. **To insert spindle seals into actuator base:** Insert ring (9), packing rings (8) and (33) in the sequence elastomer-teflon-flexible elastomer-teflon with support ring (7), spring (6), guide ring (5) and wiping ring (13) into the actuator base (25) and secure with circlip (3).
2. **To assemble spindle:** Insert the seat seal (14) into the plug (15) and secure with retaining nut (19). Secure plug (15) onto spindle (2) with pin (16). Caution: Valve plug should be flexible on spindle.
3. **To insert spindle and fit piston:** Slide the spindle assembly, with twisting movements, through the spindle seals located within the actuator base. Position the piston assembly (20), which is complete with lip ring (21) and O-ring (22), over the spindle (22) and secure with lock nut (11).
4. **To assemble actuator:** Place the spring (17) [also spring (18) where required] over the piston (20). Grease the sliding surface of the actuator housing (10), insert the O-ring (24) into the groove on the face of the sleeve (10.02). Place the actuator housing (10.01) over the spring (17)(18) and piston assembly in the inverted position. Mount on actuator base, use a press and clamp the actuator housing (10) to the actuator base (25), ensuring that the O-ring (24) is located within the groove, and secure with screw (23).
5. **Valve fitting:** Insert gasket (4) into the valve body (1). Connect the control media to the actuator and pressurize the actuator. Secure the retaining nut (7) to the valve body (1).
6. **Dismantling:** Dismantling is done in the reverse sequence.

**CAUTION: DISMANTLING OF THE ACTUATOR MUST BE UNDERTAKEN USING A PRESS, AS THE ACTUATOR IS SPRING LOADED.**

#### Fitting Instructions:

1. The valve can be mounted in any position.
2. An arrow indicates the flow direction which must be adhered to. See Figure 7.
3. Maximum permissible working pressure is indicated on the type label.
4. Minimum and maximum control pressures are indicated on the type label.
5. The valve is easy to clean and is achieved by loosening and removing the retaining nut and actuator assembly from the body.

#### Reassembly of Actuator to Valve Body:

Apply 80 psi air pressure to the actuator. This will retract the plunger. Place the actuator into the valve body. Check that the air inlet is in the correct location (the actuator may be assembled with air inlet pointing in any direction) so that the machine air line may be attached. Ensure that the retaining nut gasket is in place in the valve body. Tighten the nut. Remove air pressure from the actuator.

Reconnect the machine's air line.

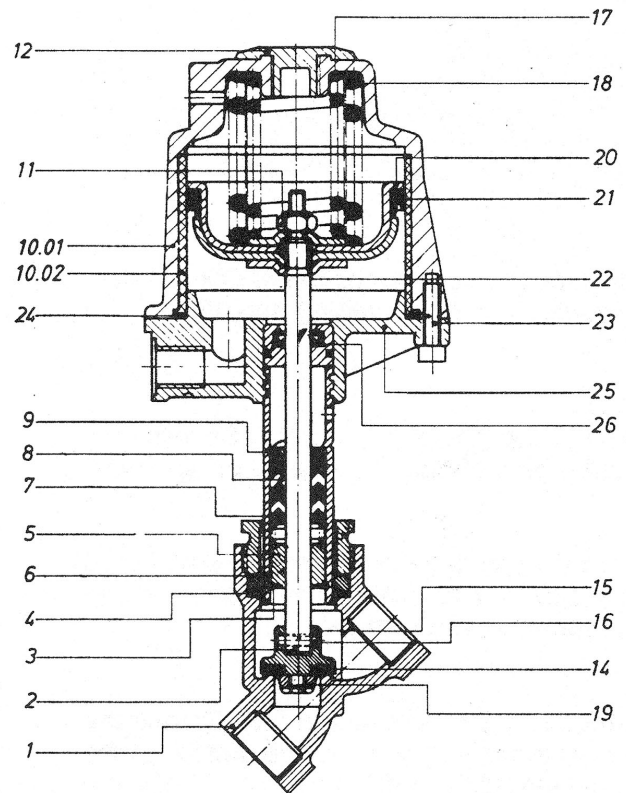

Valve Diagram **Figure 6**

1 Valve body	14 Seat seal, PTE
2 Spindle	15 Plug
3 Circlip	16 Pin
4 Gasket	17 Spring
5 Guide ring	18 Spring
6 Spring	19 Retaining nut
7 Support Ring	20 Piston assembly
8 Packing ring, PTFE	21 Lip ring
9 Ring	22 O-ring
10.01 Actuator housing	23 Socket head cap screw
10.02 Sleeve	24 O-ring
11 Lock nut	25 Actuator base
12 Cap	26 Lip ring
13 Wiping ring	33 Packing ring EPDM

Seal Kit (Items 4, 6, 7, 8, 9, 13, 14, 33)

## GEMU VALVE

2" WATER VALVE PART# 2000102

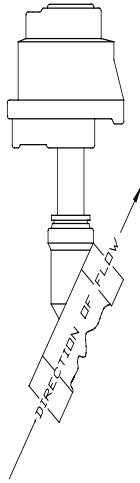

1 1/4" STEAM VALVE PART# 2000110

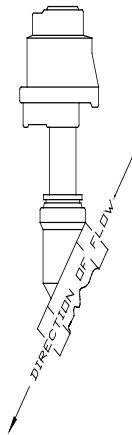

**WARNING: DISCONNECT AND BLEED OFF AIR SUPPLY PRIOR TO DISCONNECTING AIR LINES.**

- Disconnect air line to access bolt for air cylinder bracket.
- Remove air cylinder bracket and add or remove shims beneath bracket as required.
- Reassemble in reverse order.
- Check functionality by cycling UNLOCK DOOR and LOCK DOOR button and readjust as required.
- Install covers.

### DRIVE ASSEMBLY

**CAUTION: TO AVOID PERSONAL INJURY, DISCONNECT AND LOCK OUT POWER TO MACHINE PRIOR TO PERFORMING ANY WORK ON DRIVE ASSEMBLY.**

#### Drive Assembly Removal:

- To remove gearbox motor, flange bearing and/or shaft seal, the basket needs to be secured as described.
- Remove 3/4 plugs from bottom of shell and replace with 3/4-10 x 4 long hex bolt. Screw bolts in until they touch basket.
- Secure basket from front to prevent the basket from sliding towards rear of machine.
- Place saddle underneath shaft between gearbox motor and flange bearing.
- Unbolt motor and remove shims between motor plate and motor.
- Remove key retainer and slide motor off shaft with minimal up/down and side/side movement.
- Remove locking collar.
- Unbolt flange bearing and slide rearward to saddle. Place second saddle in front of flange bearing and remove first saddle and flange bearing.
- Unbolt seal housing and remove drain line. Slide seal housing back carefully ensuring the housing is perpendicular to the shaft to prevent damage to ceramic seat. Slide off shaft using two saddles with one saddle always supporting shaft.
- Slide spring/seal assembly off shaft (lubricant may be required) using two saddles with one saddle always supporting shaft.
- Reassemble in reverse order.

Valve Flow Direction **Figure 7**

### DOOR SEAL

#### Door Seal Removal:

- To replace door seal, remove old door seal and clean off the residual silicone adhesive.
- Place a small bead of clear silicone adhesive/sealant 5005 or equivalent in the door groove.
- Firmly press door seal in groove starting at the top of the door and cutting off the excess at the end. Ensure seal is seated properly in groove all around.
- Remove excess silicone adhesive and allow to cure for 24 hours.

#### Door Lock/Seal Adjustment:

- To adjust door lock/seals, add or remove shims beneath door hinges as required.
- Remove cover plates to access door locks.

**SPARE PARTS LIST**  
**MECHANICAL/ELECTRICAL SPARE PARTS LIST**

Item	Part Number	Description
1	1060035	1 HP Motor Gearbox
2	1220080	1 1/2 HP Centrifugal Pump
3	1450081	Flange Bearing
4	1300070	Ceramic Seal
5	1210055	Door Damper
6	1220078	Flow Control Valve
7	1210052	Air Cylinder
8	1210053	Switch Assembly NPN Sinking
9	5846256	Door Seal
10	0316031	1 NPT Water Valve
11	2000103	1 1/2 NPT Water Valve
12	2000102	2 NPT Water Valve
13	2000110	1 1/4 NPT Steam Valve
15	1220079	Liquid Level Control
16	2160143	RTD Probe
17	2020063	Sensor Assembly
19	TBD	Inverter, 1 HP, 208VAC

**DIAGRAMS**  
**WATER VALVE DIAGRAM**

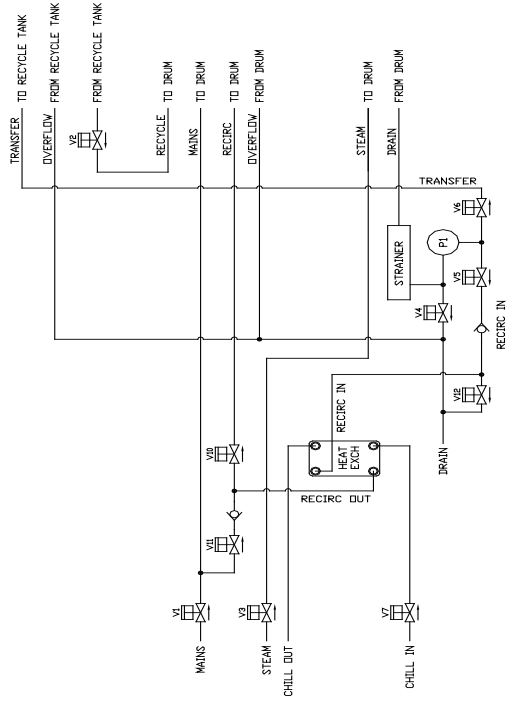



CALL FACTORY FOR REPLACEMENT PARTS:  
888-994-7636

# Parts List

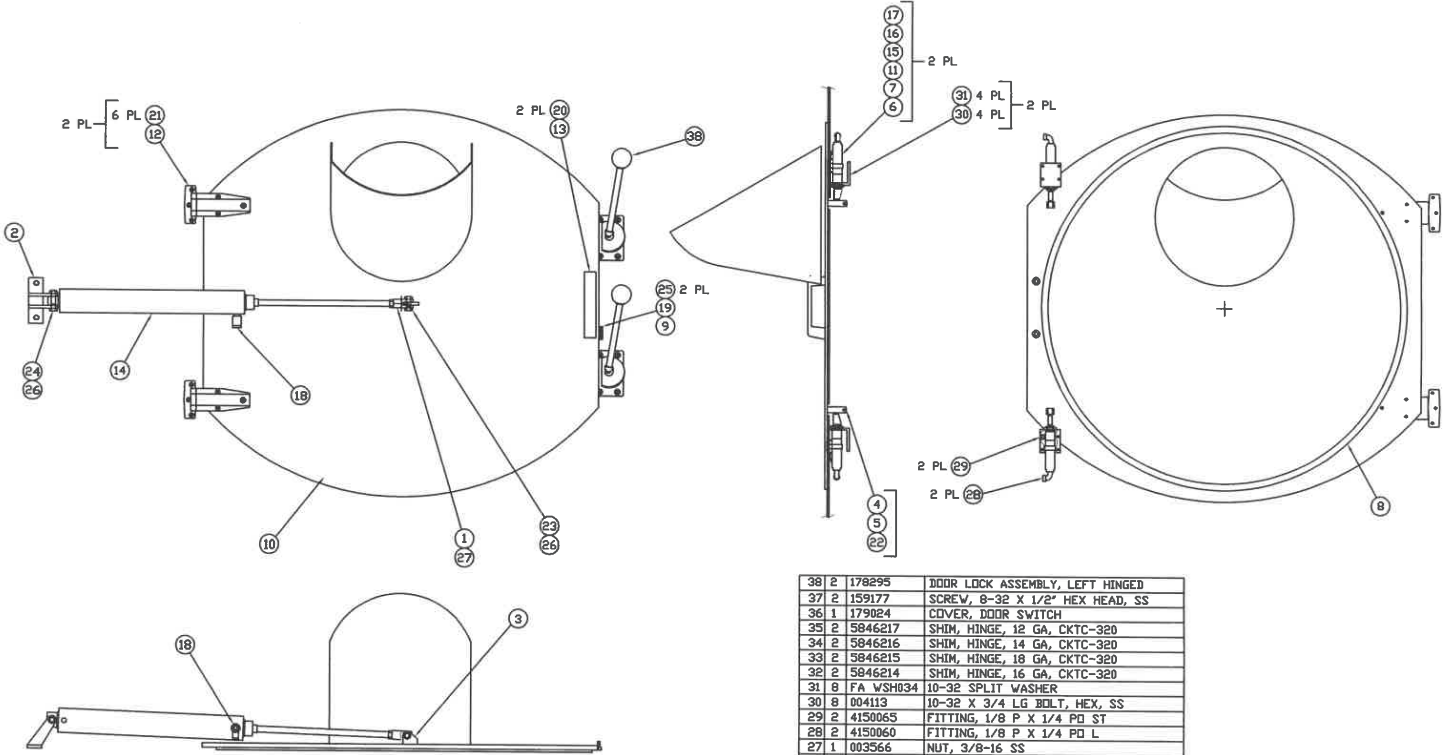

38	2	178295	DOOR LOCK ASSEMBLY, LEFT HINGED
37	2	159177	SCREW, 8-32 X 1/2" HEX HEAD, SS
36	1	179024	COVER, DOOR SWITCH
35	2	5846217	SHIM, HINGE, 12 GA, CKTC-320
34	2	5846216	SHIM, HINGE, 14 GA, CKTC-320
33	2	5846215	SHIM, HINGE, 18 GA, CKTC-320
32	2	5846214	SHIM, HINGE, 16 GA, CKTC-320
31	8	FA WSH034	10-32 SPLIT WASHER
30	8	004113	10-32 X 3/4 LG BOLT, HEX, SS
29	2	4150065	FITTING, 1/8 P X 1/4 PD ST
28	2	4150060	FITTING, 1/8 P X 1/4 PD L
27	1	003566	NUT, 3/8-16 SS
26	2	071257	NUT, LOCKING 3/8-16 SS
25	2	003122	SCREW, #4-40 X 1/8 LG PAN HEAD
24	1	005621	BOLT, 3/8-16 X 2 LG HEX HEAD SS
23	1	005616	BOLT, 3/8-16 X 1 3/4 LG HEX HEAD SS
22	2	HD PIN0305	PIN, DOWEL 3/16 X 5/8 LG 18-8 SS
21	2	005610	BOLT, ALLEN FLAT HEAD 1/4-20X1 SS
20	2	159167	BOLT, ALLEN FLATHEAD M8X1.25X20MM SS
19	1	2020062	ACTUATOR, SENSOR
18	1	162185	FLOW CONTRL VALVE THREAD COVER ASSY
17	2	1210054	CLAMP ASSY
16	2	1210053	SWITCH ASSY, NPN SINKING
15	2	1210052	CYLINDER, AIR, .75 D SRM 1.00
14	1	162187	CYLINDER, AIR, MILLED
13	1	1030330	HANDLE, PLASTIC, BLK 9-01526
12	2	1030331	HINGE, DOOR, SS, HIZ1957
11	2	5846262	SHIM, DOOR LOCK
10	1	5846289	DOOR WELDMENT
9	1	5846259	BRACKET, SENSOR
8	1	5846256	DOOR SEAL
7	2	5846255	CYLINDER BRACKET
6	2	5846254	CAM LOCK
5	2	5846253	ROLLER
4	2	5846252	DOOR LATCH
3	1	5846224	PIVOT BRACKET, DOOR
2	1	5846223	PIVOT BRACKET WELDMENT
1	1	5846220	PISTON ROD CLEVIS
ITEM	QTY	PART NUMBER	DESCRIPTION

## JAC CONTROL PANEL

CALL FACTORY FOR REPLACEMENT PARTS:  
888-994-7636

## Parts List

Item	Part Number	Description
1	176000-1	DISCONNECT HANDLE
2	176000-2	OPERATING SHAFT
3	176000-3	HMI
4	176000-4	ALARM HORN
5	176000-5	EMERGENCY STOP
6	176000-6	DISCONNECT
7	176000-7	MAIN FUSES
8	176000-8	PLC
9	176000-9	PLC OUTPUT
10	176000-10	PLC INPUT
11	176000-11	PLC MEMORY CHIP
12	176000-12	CONTROL TRANSFORMER
13	176000-13	CONTROL TRANSFORMER PRIMARY FUSES
13	176000-013	CONTROL TRANSFORMER SECONDARY FUSES
14	176000-14	ETHERNET SWITCH
15	176000-15	POWER SUPPLY
16	176000-16	SINGLE POLE 1 AMP CIRCUIT BREAKER
17	176000-17	SINGLE POLE 2 AMP CIRCUIT BREAKER
18	176000-18	SINGLE POLE 5 AMP CIRCUIT BREAKER
19	176000-19	BASKET DRIVE BREAKER OVERLOAD (CB-T1)
20	176000-20	RECIRCULATING PUMP BREAKER OVERLOAD (CB-T2)
21	176000-21	1 HP VFD
22	176000-22	VFD ETHERNET MODULE
23	176000-23	CONTACTOR
24	176000-24	DOUBLE POLE RELAY
25	176000-25	SINGLE POLE RELAY
26	176000-26	SOLENOID MANIFOLD
27	176000-27	MANIFOLD CABLE
28	176000-28	CONTROL CABLE
29	176000-29	20 FT ETHERNET CABLE
30	176000-30	2 FT ETHERNET CABLE

