



OPERATOR MANUAL

IMPORTANT INFORMATION, KEEP FOR OPERATOR

888-994-7636, fax 888-864-7636
unifiedbrands.net

THIS MANUAL MUST BE RETAINED FOR FUTURE REFERENCE. READ, UNDERSTAND AND FOLLOW THE INSTRUCTIONS AND WARNINGS CONTAINED IN THIS MANUAL.

FOR YOUR SAFETY Do not store or use gasoline or other flammable vapors and liquids in the vicinity of this or any other appliance.

WARNING Improper installation, adjustment, alteration, service or maintenance can cause property damage, injury or death. Read the installation, operating and maintenance instructions thoroughly before installing or servicing this equipment.

NOTIFY CARRIER OF DAMAGE AT ONCE It is the responsibility of the consignee to inspect the container upon receipt of same and to determine the possibility of any damage, including concealed damage. CapKold suggests that if you are suspicious of damage to make a notation on the delivery receipt. It will be the responsibility of the consignee to file a claim with the carrier. We recommend that you do so at once.

Technical Service/Questions 888-994-7636.

This manual provides information for:

STEAM JACKETED KETTLE MODEL DH-400L

- Self-Contained
- Gas Heated
- Floor Mounted
- Tilting

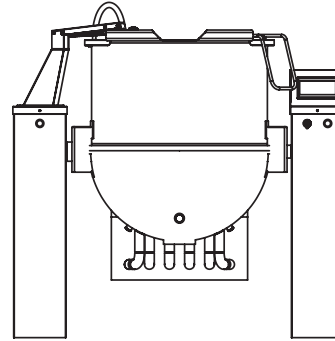

The purpose of this manual is to provide information that will aid in the installation, operation, maintenance and repair of a CapKold Steam Jacketed Kettle. This manual should be read completely before installing and/or operating this machine. While every effort is made to provide accurate and up-to-date information, CapKold reserves the right to change the specifications herein without notice. CapKold also reserves the right to make changes or improvements in products previously manufactured. The illustrations and descriptions herein are general in nature and may not include all standard equipment or may include optional equipment.

The only applicable warranty is our standard written warranty, and there is no other warranty, written or implied.

EQUIPMENT DESCRIPTION

Model DH-400L

MODEL	IGNITION	FIRING RATE, BTU/HOUR		CAPACITY	DIAMETER	OVERALL WIDTH	OVERALL FRONT-TO-BACK	RIM HEIGHT
		NATURAL GAS	PROPANE GAS					
DH-400L	Electronic	360,000	360,000	400 liters (106 gallons)	34" (86 cm)	64¼" (163 cm)	54" (137 cm)	54¼" (138 cm)

Model DH-400L is a stainless steel, steam jacketed, floor mounted, tilting kettle with a self-contained, gas heated steam source. The kettle body is welded into one piece and furnished with a reinforced bar rim and welded "butterfly" pouring lip. The interior of the kettle is polished to a 180 emery grit finish and the exterior given a uniform Number 3 finish.

The unit is ASME shop-inspected and is registered with the National Board for working pressures up to 50 PSI. Kettle supports mount directly to the floor by use of lag bolts. A power tilt feature is standard. Options available include: "Gallon Master" metering system, product outlet strainer, and a power-assist cover, and a digital time-temperature recorder.

The self-contained steam source is heated by either propane or natural gas. The ignition system is spark or standing pilot. The kettle is charged at the factory with chemically pure water containing corrosion inhibitors. The steam source provides kettle temperatures of 150 to approximately 280°F. Controls for the unit include a thermostat, pressure gauge, water level glass, safety valve, pressure limit control, low water cutoff, gas regulator valve, and a printed circuit board that monitors product temperature. The gas supply shuts down automatically when the kettle is tilted. The agitator operates only in partial rotation mode when the kettle is tilted.

The unit must be specified for use with natural or propane gas. Service connections are required for gas, electric, air (if the air-operated valve is specified), water (if Gallon Master metering is specified).

SAFETY

IMPORTANT - READ FIRST - IMPORTANT

YOUR SAFETY AND THE SAFETY OF OTHERS ARE VERY IMPORTANT.

WE HAVE PROVIDED MANY IMPORTANT SAFETY MESSAGES IN THIS MANUAL AND ON YOUR APPLIANCE. ALWAYS READ AND OBEY ALL SAFETY MESSAGES.

OUR PRODUCT INSTRUCTIONS WILL BE UPLOADED ON OUR COMPANY OFFICIAL WEBSITE.



THIS IS THE SAFETY ALERT SYMBOL. THIS SYMBOL ALERTS YOU TO POTENTIAL HAZARDS THAT CAN KILL OR INJURE YOU AND OTHERS. ALL SAFETY MESSAGES WILL FOLLOW THE SAFETY ALERT SYMBOL AND EITHER THE WORDS "DANGER", "WARNING" OR "CAUTION".

DANGER MEANS THAT FAILURE TO HEED THIS SAFETY STATEMENT MAY RESULT IN SEVERE PERSONAL INJURY OR DEATH.



WARNING MEANS THAT FAILURE TO HEED THIS SAFETY STATEMENT MAY RESULT IN EXTENSIVE PRODUCT DAMAGE, SERIOUS PERSONAL INJURY, OR DEATH.



CAUTION MEANS THAT FAILURE TO HEED THIS SAFETY STATEMENT MAY RESULT IN MINOR OR MODERATE PERSONAL INJURY, OR PROPERTY OR EQUIPMENT DAMAGE.

ALL SAFETY MESSAGES WILL ALERT YOU TO WHAT THE POTENTIAL HAZARD IS, TELL YOU HOW TO REDUCE THE CHANCE OF INJURY, AND LET YOU KNOW WHAT CAN HAPPEN IF THE INSTRUCTIONS ARE NOT FOLLOWED.

FOLLOW BASIC PRECAUTIONS, INCLUDING THE FOLLOWING:

- WARNING: FAILURE TO DISCONNECT POWER BEFORE SERVICING COULD RESULT IN ELECTROCUTION AND DEATH.
- WARNING: IMPROPER INSTALLATION, ADJUSTMENT, ALTERATION, SERVICE OR MAINTENANCE CAN CAUSE PROPERTY DAMAGE, INJURY OR DEATH. READ THE INSTALLATION, OPERATING AND MAINTENANCE INSTRUCTIONS THOROUGHLY BEFORE INSTALLING OR SERVICING THIS EQUIPMENT.
- WARNING: DO NOT PLACE HANDS, TOOLS OR HOSES IN KETTLE WHILE AGITATOR IS MOVING. AGITATOR CAN BE JOGGED WHILE KETTLE IS TILTED.
- WARNING: THE UNIT MUST BE INSTALLED BY PERSONNEL QUALIFIED TO WORK WITH ELECTRICITY AND PLUMBING. UNIT MUST BE INSTALLED IN ACCORDANCE WITH ALL APPLICABLE CODES.
- WARNING: DO NOT ATTACH THE UNIT TO A TYPE "B" VENT. IT COULD CAUSE FIRE OR PROPERTY DAMAGE.
- WARNING: DO NOT CONNECT ANY PIPING TO THE SAFETY VALVE. IT MUST BE FREE TO VENT STEAM AS NEEDED. TO AVOID BURNS FROM THE VENTED STEAM THE VALVE DISCHARGE SHOULD POINT DOWNWARD.

- DANGER: ELECTRICALLY GROUND THE UNIT AT THE TERMINAL PROVIDED. FAILURE TO GROUND THE UNIT COULD RESULT IN ELECTROCUTION AND DEATH.
- CAUTION: BE SURE ALL OPERATORS READ, UNDERSTAND AND FOLLOW THE OPERATING INSTRUCTIONS, CAUTIONS AND SAFETY INSTRUCTIONS CONTAINED IN THIS MANUAL.
- CAUTION: DO NOT OVERFILL THE KETTLE WHEN COOKING, HOLDING OR CLEANING. KEEP LIQUIDS A MINIMUM OF 2-3" (5-8 CM) BELOW THE KETTLE BODY RIM TO ALLOW CLEARANCE FOR STIRRING, BOILING AND SAFE TRANSFER OF PRODUCT.
- CAUTION: KEEP FLOORS IN FRONT OF KETTLE WORK AREA CLEAN AND DRY. IF SPILLS OCCUR, CLEAN IMMEDIATELY TO AVOID SLIPS OR FALLS.
- WARNING: KEEP WATER AND SOLUTIONS OUT OF CONTROLS AND BURNERS. NEVER SPRAY OR HOSE DOWN THE CONTROL CONSOLE, ELECTRICAL CONNECTIONS, ETC.
- CAUTION: MOST CLEANERS ARE HARMFUL TO THE SKIN, EYES, MUCOUS MEMBRANES AND CLOTHING. TAKE PRECAUTIONS: WEAR RUBBER GLOVES, GOGGLES OR FACE SHIELD AND PROTECTIVE CLOTHING. CAREFULLY READ WARNINGS AND FOLLOW DIRECTIONS ON CLEANER LABELS .
- NOTICE: NEVER LEAVE A SANITIZER IN CONTACT WITH STAINLESS STEEL SURFACES LONGER THAN 10 MINUTES. LONGER CONTACT CAN CAUSE CORROSION.
- WARNING: FAILURE TO PERIODICALLY CHECK SAFETY VALVE OPERATION COULD RESULT IN PERSONAL INJURY AND/OR DAMAGE TO EQUIPMENT.
- WARNING: WHEN TESTING, AVOID EXPOSURE TO THE STEAM BLOWING OUT OF THE SAFETY VALVE. DIRECT CONTACT COULD RESULT IN SEVERE BURNS.
- WARNING: TO AVOID INJURY, READ AND FOLLOW ALL PRECAUTIONS STATED ON THE LABEL OF THE WATER TREATMENT COMPOUND.
- WARNING: BEFORE REPLACING ANY PARTS, DISCONNECT THE UNIT FROM THE ELECTRIC POWER SUPPLY AND CLOSE THE MAIN GAS VALVE. ALLOW FIVE MINUTES FOR GAS TO VENT.
- CAUTION: USE OF ANY REPLACEMENT PARTS OTHER THAN THOSE SUPPLIED BY GROEN OR AUTHORIZED DISTRIBUTORS CAN CAUSE INJURY TO THE OPERATOR AND DAMAGE TO THE EQUIPMENT AND WILL VOID ALL WARRANTIES.
- WARNING: KEEP AREA AROUND KETTLE FREE AND CLEAR OF ALL COMBUSTIBLE MATERIALS. FAILURE TO DO SO COULD RESULT IN FIRE OR PROPERTY DAMAGE.
- CAUTION: HEATING AN EMPTY KETTLE MAY CAUSE THE RELEASE OF STEAM FROM THE SAFETY VALVE.
- IMPORTANT: SERVICE PERFORMED BY OTHER THAN FACTORY AUTHORIZED PERSONNEL WILL VOID ALL WARRANTIES.

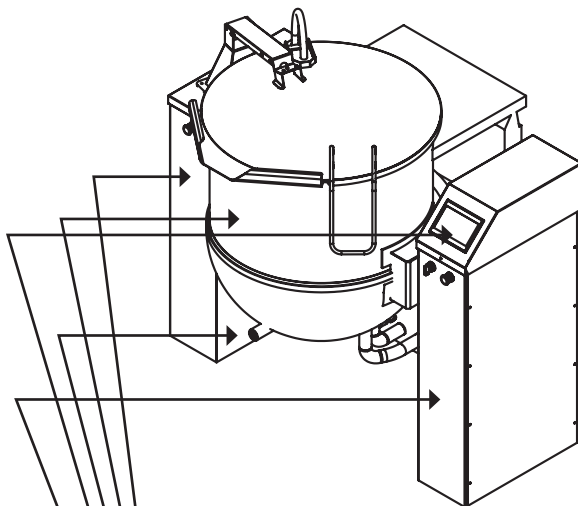

- Left Stanchion
- Kettle Body Assembly
- Sight Glass
- Touch Screen Control
- Right Stanchion

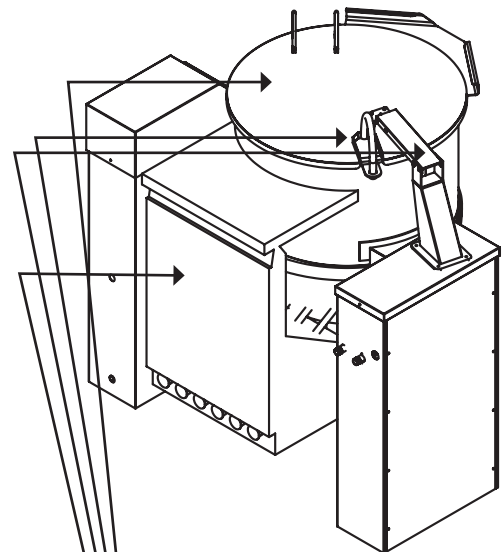

- Cover
- Fill Spout
- Power-Aid Hinge
- Flue Stack, Combustion Chamber and Burner Assemblies

INSPECTION & UNPACKING

WARNING: THIS UNIT MUST BE INSTALLED BY PERSONNEL WHO ARE QUALIFIED TO WORK WITH ELECTRICITY AND PLUMBING. IMPROPER INSTALLATION CAN CAUSE INJURY TO PERSONNEL AND/OR DAMAGE TO THE EQUIPMENT. THE UNIT MUST BE INSTALLED IN ACCORDANCE WITH APPLICABLE CODES.

WARNING: SHIPPING CHANNELS (BRACES) ARE VERY HEAVY. USE PROPER LIFTING AND HANDLING EQUIPMENT FOR MOVEMENT.

CAUTION: WATCH OUT FOR NAILS AND SPLINTERS WHILE DISMANTLING THE SHIPPING CRATE.

CAUTION: UNIT HAS AN APPROXIMATE SHIPPING WEIGHT OF 1600 LBS. (727 KG.). FOR SAFE HANDLING, INSTALLER SHOULD OBTAIN PROFESSIONAL RIGGING HELP AS NEEDED AND USE MATERIAL HANDLING EQUIPMENT (SUCH AS A FORKLIFT, OVERHEAD HOIST, OR PALLET JACKS) TO REMOVE THE UNIT FROM THE SKID AND MOVE IT TO ITS PLACE OF INSTALLATION.

WARNING: TO AVOID DAMAGE OR INJURY, FOLLOW THE ELECTRICAL SCHEMATIC EXACTLY WHEN CONNECTING THE UNIT.

The unit is delivered completely assembled, on a heavy skid surrounded by a wooden crate. Immediately upon receipt, inspect the unit for damage. Report any shipping damage or an incorrect shipment to the delivery agent.

Write down the model number, serial number, and installation date of your unit, and keep this information for future reference. Space for these entries is provided at the top of the Service Log provided at the rear of this manual. The unit is anchored to two metal shipping channels (braces) which may be discarded after installation. Carefully unbolt one side of shipping channel. Position the kettle and remove second shipping channel.

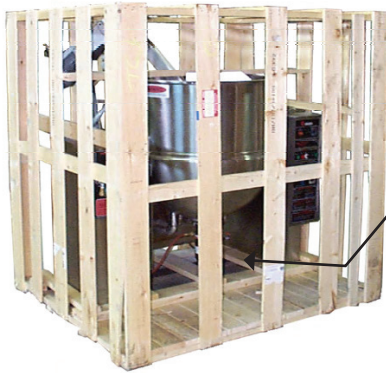

The unit is delivered crated and bolted to a heavy skid.

Two heavy shipping channels (braces) anchor the unit for shipment.

Shipping Channels (Braces)

When installation is to begin, unbolt the unit from the skid, and lift the unit straight up and off the skid.

UTILITY REQUIREMENTS

1. Electrical Supply Connection-3 Phase Operation Only

- The panel must be removed to gain access to the electrical supply connection. Open the wiring and control panel by unscrewing the eight screws which hold it in place. Grasp the panel by the base at the bottom edge. While lifting the panel, swing its bottom toward you. Set the panel aside.
- Supply Voltage:** The unit must operate at the rated nameplate voltage, plus or minus 10 percent.
- Wiring Information:** Refer to the electrical schematic for wiring information. A copy of the schematic is found inside the control panel and at the rear of this manual.
- Terminal Block:** The terminal block for incoming power is located at the back of the control compartment. The ground terminal is located next to the terminal block. The unit must have a separate ground wire for safe operation.
- High Voltage safety

- Branch Circuit Protection:** Each conductor must have over-current protection. Refer to the label on the back of the unit for the proper wire type and size. Connections to the unit must be watertight.

We strongly recommend that the Kettle have its own branch circuit protection. Current and power demands for the different voltage units are as follows:

Maximum Voltage Three Phase Current, Per Line

208 Volts	7 AMP
240 Volts	7 AMP
480 Volts	3.5 AMP

2. Water Connection(s)

Install a check valve in the incoming cold water line, if required by local plumbing codes. Water pressure in the line should be between 30 and 60 PSIG (210 and 420 kPa). A 3/4 NPT connector is needed to attach the water supply to the water inlet valve. The minimum recommended water feed line diameter is 1/2 inch (13mm). Do not allow the connection to leak, no matter how slowly. THE INSTALLER MUST PROVIDE THE CHECK VALVE (ANTI-SYPHON DEVICE) IF REQUIRED BY LOCAL CODES.

3. Gas Connection

Connect 1 NPT gas line to the gas inlet valve on the rear of the left stanchion. Be sure that the gas supply meets the following criteria:

	NATURAL GAS	PROPANE
Minimum	7" W.C.	11" W.C.
Maximum	10" W.C.	14" W.C.

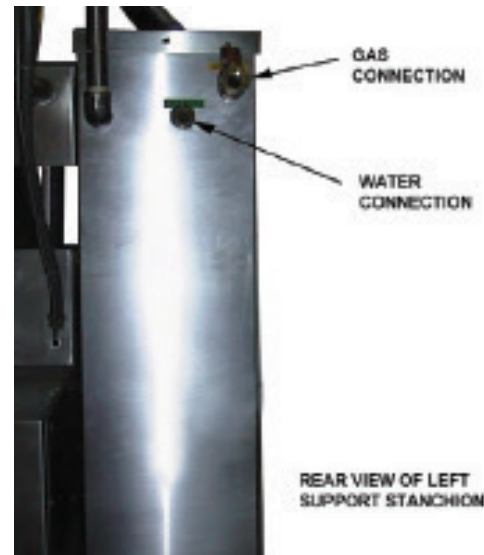

Gas and Water Connections are on the back of the left stanchion.

INSTALLATION

WARNING: THIS UNIT IS FOR COMMERCIAL USE. NEVER USE HOME OR RESIDENTIAL GRADE GAS CONNECTIONS. THEY DO NOT MEET GAS CODES AND COULD BE HAZARDOUS.

WARNING: DO NOT ATTACH THE UNIT TO A TYPE "B" VENT. FAILURE COULD RESULT IN FIRE OR PROPERTY DAMAGE.

WARNING: DO NOT CONNECT ANY PIPING TO THE POP SAFETY VALVE. IT MUST BE FREE TO VENT STEAM AS NEEDED. THE ELBOW SHOULD POINT DOWN TOWARD FLOOR. IMPROPER INSTALLATION WILL VOID WARRANTY.

DANGER: ELECTRICALLY GROUND THE UNIT AT THE TERMINAL PROVIDED. FAILURE TO GROUND UNIT COULD CAUSE ELECTROCUTION AND DEATH.

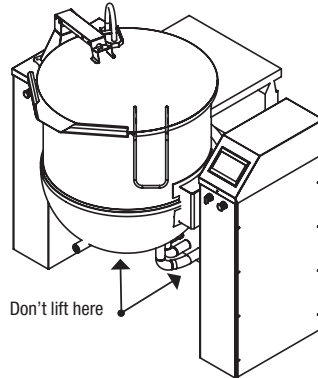
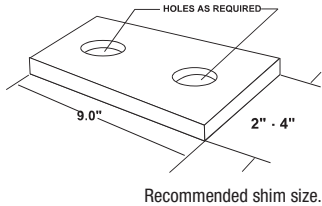

The unit should be installed in a well-ventilated room on non-combustible flooring. Anything which might obstruct or restrict the flow of air for combustion and ventilation must be removed. The area directly around the appliance must be free of combustible materials.

1. Installation requires connection with air, gas, water and electric services. See items 8 to 14 for details.
2. To protect the unit from damage, leave it on the shipping pallet until installation. When ready to start installation, disassemble the shipping crate, unbolt the stanchions, disconnect the shipping channels (braces) and raise the unit straight up off the skid. Do not lift the kettle at the heat exchanger. Lifting the kettle at the heat exchanger could damage the unit.
3. Install the unit with at least 22 inches clearance from the back walls. Also leave enough room for easy cleaning, maintenance, and service.
4. Do not alter the kettle in any way. Any mechanical, electrical, or gas change must be approved by the Food Service Engineering Department.
5. Level the unit as follows:

The stanchions are each supplied with a drip tray in which the angle frame is placed. Steel leveling shims (not included, supplied by installer) are placed between the drip tray and frame so that the drip tray will be flush with the floor, as shown.

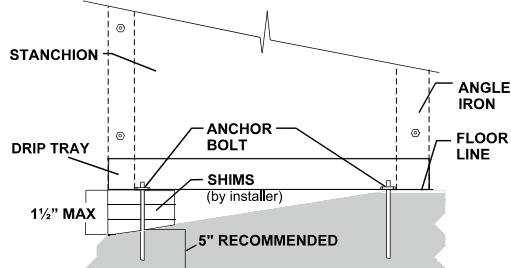

Start with the right stanchion and level it as shown in the sketch. Once the right stanchion is levelled and properly anchored front to rear, level the left stanchion front to rear and side to side.

Level the entire unit side to side by placing a four foot carpenter's level on the kettle rim. Once the rim is level from side to side, rotate the level to check front to back. Shim the left stanchion in the same manner as the right, and anchor the equipment firmly to the floor through the shims.

6. Make sure the jacket water level is correct by confirming that it is in the middle of the bulls-eye sight glass at the front of the kettle. If the water level is low, follow the instructions under "Jacket Filling" in the "Maintenance" Section of this manual.
7. To protect personnel from steam coming from the safety valve, the open end of the elbow at the outlet must be directed downward. If it is not, turn the elbow to the correct position.
8. INSTALL:

Check valve in the incoming cold water line, if required by local plumbing codes, as described in Paragraph 2, page 3.

9. Provide electrical service per Paragraph 1, Electrical Supply Connection in the Inspection and Unpacking, Requirements Section, Page 6. Use ½ inch waterproof conduit and waterproof connections. Observe local Codes and/or The National Electrical Code in accordance with ANSI/NFPA 70 - latest edition. AN ELECTRICAL GROUND IS REQUIRED. The electrical schematic is located on the inside of the service panel. In Canada, provide electrical service in accordance with the Canadian Electrical code, CSA C22.1 Part 1 and/or local codes.
10. The internal gas lines of the unit were cleaned and closed with a gas cock before the unit was shipped from the factory. Ensure that external gas lines are free of lint, dirt, metal chips, sealant, grease, oil or other contaminants, before you connect the line to the kettle.
11. Connect the kettle gas cock to the gas service main using a 1" NPT gas connection.
12. Installation must conform with local codes, or in the absence of local codes, with the National Fuel Gas Code, ANSI Z 223.1-1988 (or latest edition). The unit should be installed in a well-ventilated room with a provision for adequate air supply. The best ventilation will use a vent hood and exhaust fan with no direct connection between the vent duct and the unit flue.

Do NOT obstruct the flue or vent duct after installation. In Canada, the installation must conform with the CAN/CGA B149 Installation Codes for Gas Burning Appliances and Equipment and/or local codes.
13. Adequate space for proper service and operation is required. Do NOT block any air intake spacings to the combustion chamber or obstruct the air flow by piling or stacking anything near the kettle.
14. After the kettle has been connected to the gas supply, all gas line joints must be checked for leaks. DO NOT USE A FLAME TO CHECK FOR LEAKS. A thick soap solution or other suitable leak detector should be used.
15. The appliance and its individual shutoff valve must be disconnected from the gas supply piping system during any pressure testing of that system at test pressures in excess of ½ PSIG (3.48 kPa). The appliance must be isolated from the gas supply piping system by closing its individual manual shutoff valve during any testing of the gas system at pressures equal to or less than ½ PSIG (3.48 kPa).

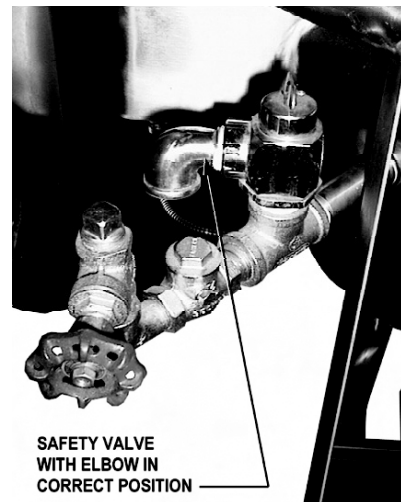

16. Check the following to confirm that your kettle has been installed properly:
 - Enough room between the kettle and nearby objects for cleaning and service.
 - Minimum clearance of 24 inches from sides and 24 from back.
 - Unit vented to an exhaust hood.
 - Kettle level.
 - Correct amount of water in the jacket.
 - Safety valve outlet pointed down.
 - Connected with a waterproof electric power cable in accordance with Paragraph 1 Electrical Supply Connection (above) and local electrical codes.
 - Gas lines cleaned before connection.
 - Gas connected with 1 NPT or larger.
 - Gas line joints checked for leaks.
 - No obstruction to air supply or venting.
 - Gas lines (1 NPT) connected to supply.
 - Water supply connection (¾") completed.

INITIAL START-UP

After the kettle has been installed, the installer should test to ensure that the unit is operating correctly.

1. Remove all literature and packing materials from the inside and outside of the unit. Clean out any material that might clog or damage the product outlet.
2. Add 50 gallons (180 liters) of water to the kettle to provide sufficient product for testing.
3. Make sure the supplies of gas and electric power are on.
4. Following "Start Kettle Heating" instructions in the "Operating Instructions" section of this manual, begin heating the water at the highest thermostat setting. The pilot lamp should come on as soon as you pull out the emergency stop and turn on power. Heating should continue until the water boils.
5. To turn off the unit, follow "To Stop Kettle Heating" in "Operating Instructions," below. If the kettle functions as described, it is ready for use. If the unit does not operate as designed, contact an authorized Service agent.

OPERATION

WARNING: ANY POTENTIAL USER OF THE EQUIPMENT MUST BE TRAINED IN SAFE AND CORRECT OPERATING PROCEDURES.

WARNING: KEEP AREA AROUND KETTLE FREE AND CLEAR OF ALL COMBUSTIBLE MATERIALS.

CAUTION: HEATING AN EMPTY KETTLE MAY CAUSE THE RELEASE OF STEAM FROM THE SAFETY VALVE.

WARNING: DO NOT ATTEMPT TO LIGHT PILOT MANUALLY WITH A FLAME.

CAUTION: KEEP FLOORS IN FRONT OF KETTLE WORK AREA CLEAN AND DRY. IF SPILLS OCCUR, CLEAN IMMEDIATELY TO AVOID THE DANGER OF SLIPS OR FALLS.

WARNING: DO NOT STAND IN FRONT OF KETTLE DURING TILTING. PRODUCT IS HOT AND WILL CAUSE BURNS. EXERCISE EXTREME CARE WHEN HANDLING OR NEAR HOT OR BOILING LIQUIDS.

CONTROLS

Refer to the drawing on the following page for identification and function of kettle controls.

OPERATING INSTRUCTIONS

Refer to the drawing on the following page for identification and function of kettle controls.

1. **CHECK THE WATER LEVEL IN THE JACKET EVERY DAY.** The level must be in the middle of the bulls-eye sight glass. If the level is low, see "Jacket Filling" in the "Preventive Maintenance" section of this manual.
2. With the kettle cold, check the pressure gauge. If it does not show 20 or more inches of vacuum (a reading of 20 to 30 below 0), see "Jacket Vacuum" in the "Preventive Maintenance" section of this manual.
3. **Start Kettle Heating**
 - a. Open main gas supply valve.
 - b. Pull **OUT** the emergency stop and turn **ON** the control power switch on the front of the right stanchion.
 - c. The touch-screen control panel should be ON (if not, check that mains power is connected to the unit and the mains circuit breaker is on).

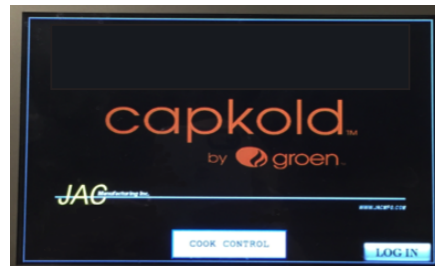

4. Cooking Control

- a. Touch the **COOK CONTROL** on the screen. The display will change to show the main cooking control screen. This screen allows user to control kettle tilt, cooking operation, water fill, turbo heat; and displays current product temperature in degrees Celsius, desired cooking temperature in degrees Celsius; and lamp status of the pilot, main gas valve, low fire burner and high fire burner.



- b. Ensure kettle is tilted fully upright. If not, press **TILT CONTROL** on the screen. The pop-up tilt control will appear. Press continuously on either **TILT UP** or **TILT DOWN** until the kettle comes to a fully upright position. The tilt controls will turn bright green when pressed and will go dark when released [Note: Press **TILT CONTROL** to minimize the tilt feature on the screen.]

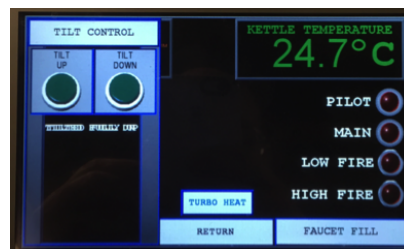

- c. The **PILOT** and **MAIN** indicators on the screen should show green.

- d. Press **FAUCET FILL** on the screen. The pop-up faucet fill controls will appear.



The kettle can be filled automatically or manually by tapping on the **FILL** control.



- i. In the **AUTO** mode, tap on the **WATER FILL SET POINT** – a display will appear allowing you to select a desired quantity of Liters and enter them.



Tapping once on the **START FILL** control will initiate water fill through the faucet. The control will turn bright green during the fill operation and go dark once the fill set point is reached. Automatic fill can be interrupted by either setting the **FILL** switch to **MANUAL** or pushing in an **EMERGENCY STOP**.

- ii. In the **MANUAL** mode, press on the **START FILL** control and hold until the desired quantity of water is delivered through the faucet. The **TOTAL LITERS** counter can be used to observe manual fill operation – press the **RESET COUNTER** to clear the indication before starting manual fill operation.
- iii. Kettle **MUST NOT** be allowed to heat without at least 25% of its capacity of product/water present. The rate-of-Rise feature will shut the kettle down if there is insufficient product present during heating.

NOTE: Press **FAUCET FILL** to minimize the water fill feature on the screen.

- e. Press **COOK CONTROL** on the screen. The pop-up cook controls will appear.

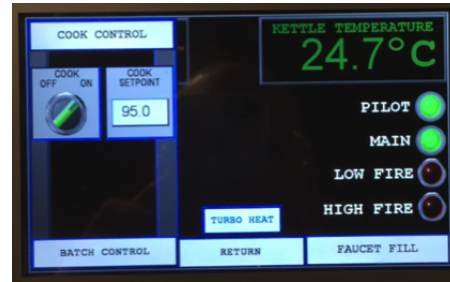

- i. Tap on the **COOK SET POINT** to bring up a key pad to select the desired cooking temperature. Enter the numerical value in degrees Celsius and press **ENTER**. The display should change to the selected value.
- ii. Tap the **COOK** switch to turn **ON** or **OFF** the cook function. During the cook function the burners will cycle to provide the necessary amount of heating – during heat up to cook temperature, both the **LOW FIRE** and **HIGH FIRE** burner indicators will indicate green – once the temperature approaches the set point, the **HIGH FIRE** burner will shut off and the indicator will go dark.

NOTE: The **BATCH CONTROL** function is used in conjunction with an externally located multi-channel electronic chart controller. Both the kettle and the chart recorder have to be connected to an Ethernet router to allow communications between devices. Setup and operation of the batch control function are described in a separate manual.

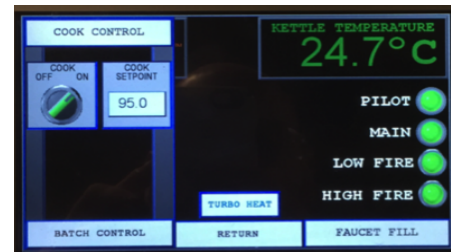

- iii. The **TEMPERATURE RATE OF RISE EXCEEDED!!!** Caution will appear on screen and shut the unit down on both low and high fire. Add more water or product to the kettle, press the **ROR RESET** to clear the lockout, and restart the kettle cooking feature by switching the **COOK** switch to **ON**.

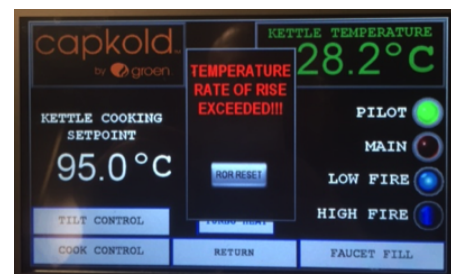

- f. Once the cooking set point is reached, the **TURBO HEAT** function can be used to provide a short burst (factory preset at 30 seconds) of both high and low fire if needed to fine tune the cooking function.
- g. If mains power is interrupted during a cooking cycle, the kettle and display will power up automatically, but the cook cycle will have to be re-started on the **COOK CONTROL** pop-up display. All of the setting will have been preserved in non-volatile memory, and will not have to be re-entered.
- h. To turn off the cook process, tap the **COOK** switch on the **COOK CONTROL** display to the **OFF** position. Both the **LOW FIRE** and **HIGH FIRE** indicators should go dark.

- i. To empty the kettle, first raise the cover, and then press the **TILT DOWN** button on the **TILT CONTROL** display to slowly empty the kettle contents into suitable capacity container(s).

5. Kettle Shut-Down

- a. Clean the kettle thoroughly at the end of a cook cycle, making sure that all surfaces are free of dirt and cooking material. Sanitize all cooking surfaces, let dry and rinse clear.
- b. Turn **OFF** the control power switch on the front of the right stanchion.
- c. If the kettle will remain off for more than one day, turn off the mains power circuit breaker switch.

PRESSURE GAUGE/INDICATORS/WATER LEVEL



Check Vacuum and Water Level Daily

LEFT & RIGHT STANCHION CONTROLS



SHUTDOWN

The disconnect switch should only be used to power off the system for service or an emergency circumstance.

Improper shutdown results in possible file corruption in the system. Improper shutdown may consist of:

- Windows is stopped before proper shutdown is performed
- Power outage

Shutdown Process

1. The system can be shut down correctly by logging into the HMI as:
UserID: ENG, Password: 100.
2. Navigate to the Settings display.
3. Select Shutdown HMI Application.
4. Once the Windows desktop is shown, go to the Windows start menu.
5. Select Shutdown.

Once Windows is shut down correctly, it is safe to turn off the disconnect.

Power Outage Recovery

1. Shutdown the HMI app using step 1 above. Do NOT shut down Windows.
2. Once on the desktop, locate the folder and files:
C:\Drive\CDRIVE FOLDERS\HMI PROGRAM etc.
3. Verify the Backup exists (if not, notify Service department).
4. Delete the file without the -ENG BCKUP file name.
5. Copy the file with the -ENG BCKUP file name and paste in the same location. It will be indicated by having -COPY after the file name.
6. Rename the file without the words -ENG BACKUP-COPY, naming it as the file that was previously deleted.
7. Restart the HMI.

CLEANING

WARNING: KEEP WATER AND SOLUTIONS OUT OF CONTROLS AND ELECTRICAL EQUIPMENT. DO NOT USE A HIGH PRESSURE HOSE TO CLEAN THE CONTROL CONSOLE, ELECTRICAL CONNECTIONS, ETC.

CAUTION: NEVER LEAVE A CHLORINE SANITIZER IN CONTACT WITH STAINLESS STEEL SURFACES FOR LONGER THAN 30 MINUTES. LONGER CONTACT CAN CAUSE CORROSION.

CAUTION: MOST CLEANERS ARE HARMFUL TO THE SKIN, EYES, MUCOUS MEMBRANES AND CLOTHING. PRECAUTIONS SHOULD BE TAKEN TO WEAR RUBBER GLOVES, GOGGLES OR FACE SHIELD AND PROTECTIVE CLOTHING. CAREFULLY READ THE WARNINGS AND FOLLOW LABEL DIRECTIONS.

1. Suggested Cleaning Supplies:

- a. A high quality detergent and sanitizer, or a combination cleaning-sanitizing agent.
- b. Kettle brushes in good condition.
- c. Spray Degreaser (PN 114801) or equivalent.
- d. De-limer/De-scaler (PN 114800) or equivalent.
- e. A high quality stainless steel cleaner.

2. Precautions

Before any cleaning operation, turn off the burner system by setting the COOK switch on the COOK CONTROL screen to the OFF position. Cut off electric power to the unit by setting the CONTROL POWER switch to the OFF position.

3. Procedure

- a. Clean food contact surfaces as soon as possible after use, preferably while the kettle is still warm. If the unit is in continuous use, clean and sanitize inside and outside at least once every 12 hours.
- b. Scrape and flush out large amounts of food residues. Be careful not to scratch the kettle with metal implements.
- c. Prepare a solution of the detergent/cleaning compound as instructed by the supplier. Clean the unit thoroughly. A cloth moistened with cleaning solution can be used to clean controls, housing, electrical conduit, etc.
- d. Rinse the kettle thoroughly with hot water. Then drain completely.

- e. As part of the daily cleaning program, clean all inside and outside surfaces that may have been soiled. Remember to check such parts as the underside of the cover, control housing, etc.
- f. To remove burned-on foods, use a brush, sponge, cloth, plastic or rubber scraper, or plastic wool along with the cleaning solution. To reduce effort required in washing, let the detergent solution sit in the kettle for a few minutes and soak into the residue. Do NOT use abrasive materials or metal tools that might scratch the surface. Scratches make the surface harder to clean and provide places for bacteria to grow. Do not use steel wool, which will leave particles in the surface and cause eventual corrosion and pitting.
- g. The outside of the unit may be polished with a recognized stainless steel cleaner.
- h. When the equipment needs to be sanitized, use a sanitizing solution equivalent to one that supplies 100 parts per million chlorine. Obtain advice on the best sanitizing agent from your supplier of sanitizing products. Following the suppliers instructions, apply the sanitizing agent after the unit has been cleaned and drained. Rinse off the sanitizer thoroughly.
- i. It is recommended that each piece of equipment be sanitized just before use.
- j. If there is difficulty removing mineral deposits or a film left by hard water or food residues, clean the kettle thoroughly and then use a deliming agent, like Delimer/Descaler (Part Number 114800), in accordance with the manufacturer's directions. Rinse and drain the unit before further use.
- k. If cleaning problems persist, contact your cleaning product supplier for assistance. The supplier has a trained technical staff with laboratory facilities to serve you.



Use a brush, sponge, cloth, plastic or rubber scraper, or plastic wool to clean.



Don't use metal implements or steel wool when cleaning.

MAINTENANCE

WARNING: AVOID ANY EXPOSURE TO THE STEAM BLOWING OUT OF THE SAFETY VALVE. SEVERE BURNS CAN RESULT ON EXPOSED SKIN. FAILURE TO CHECK SAFETY VALVE OPERATION PERIODICALLY COULD RESULT IN PERSONAL INJURY AND/OR DAMAGE TO EQUIPMENT. WHEN TESTING, AVOID ANY EXPOSURE TO THE STEAM BLOWING OUT OF THE SAFETY VALVE. DIRECT CONTACT COULD RESULT IN SEVERE BURNS.

WARNING: TO AVOID INJURY, READ AND FOLLOW ALL PRECAUTIONS STATED ON THE LABEL OF THE WATER TREATMENT COMPOUND.

WARNING: AVOID ANY EXPOSURE TO THE STEAM BLOWING OUT OF THE SAFETY VALVE. SEVERE BURNS CAN RESULT ON EXPOSED SKIN.

This section describes actions the operator must take to maintain warranty coverage and to keep the unit working safely and efficiently.

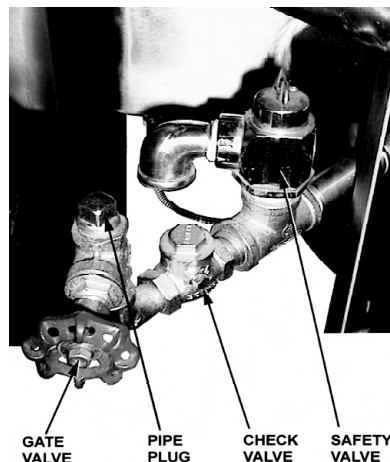

1. Jacket Vacuum/Removing Air from Jacket

Every day, while the kettle is cold, read the pressure/vacuum gauge. A positive pressure reading or a vacuum reading between zero and 20 on the pressure/ vacuum gauge indicates excess air in the jacket. Air in the jacket slows kettle heating and can prevent the kettle from reaching operating temperature. To remove air:

- a. Start the kettle. (See the "Operation" section of this manual).
- b. Make sure the elbow on the outlet of the safety valve is turned so it will direct escaping steam down toward the floor.
- c. When the pressure/vacuum gauge reaches a positive pressure reading of five PSI, release entrapped air and steam by lifting the safety valve lever for about one second. Repeat this step, then let the valve lever snap back into the closed position, so the valve will seat properly and not leak.

2. Test Safety Valve

At least twice a month, test the safety valve. Test the valve with the kettle operating at 15 psi (105 kPa), by holding the test lever for at least five seconds. Then release the lever and permit the valve to snap shut. If the lever does not activate, there is no discharge, or the valve leaks, stop using kettle immediately and contact a qualified factory service representative.

3. Jacket Filling

Every day, before you turn on the unit, make sure the water level is between the marks on the water gauge glass. The jacket was filled at the factory with the proper amount of treated water. From time to time, you may need to restore the water to its proper level, either because water was lost as steam during venting or because treated water was lost by draining. The procedure follows.

- a. If you are replacing water lost as steam, use distilled water. Do not use tap water. If you are replacing treated water that was drained from the jacket, prepare more treated water first, as directed below.

- b. Allow the kettle to cool completely. Remove the pipe plug from the jacket fill assembly. Then open the gate valve and pour in the distilled or treated water. Using a funnel will help you in this process. Hold the safety valve open while you pour, to let air escape from the jacket. Continue adding water until the water level rises to a point between the marks on the gauge glass.
- c. Close the gate valve.
- d. Air that gets into the jacket during the filling operation must be removed because it will make heating less efficient. Follow the procedure in "Jacket Vacuum," above to restore a negative pressure reading.

4. Water Treatment

- a. Fill a mixing container with the amount of water required (distilled water preferred). The kettle requires 5½ gallons (20.4 liters).
- b. Follow instructions. Apply to water treatment kit part number 110324.
- c. Hang a strip of pH test paper on the rim of the container, with about 1 inch of the strip below the surface of the water.
- d. Stir the water continuously, while you slowly add water treatment compound until a color between indicating a pH of 10.5 and 11.5 is reached. (Shown on the pH test kit chart.) Judge the pH by frequently comparing the test strip with the color chart provided in the pH test kit.
- e. Use a measuring cup to add the compound so that you may record the exact amount used. The amount may be used again, if the same water sources and compound are used in the future. However, it is best to check the pH each time treated water is prepared.

5. Venting System

Periodically check the hood to make sure that nothing will block or hinder the free flow of exhaust gases.

A Service Log is provided at the rear of this manual. Each time service is performed on this equipment, enter the date on which the work was done, and who did it. Keep this manual with the equipment.

1. Periodic Service

Periodic inspection will minimize equipment down time and increase efficiency of operation. The following points should be checked regularly.

- a. Every day, when the kettle is cold, the pressure/vacuum gauge should show a vacuum of 20 to 30 inches. If it does not, see "Jacket Vacuum" in the "Preventive Maintenance" section of this manual.
- b. Every day, the jacket water level must be in the middle of the bulls-eye sight glass. If it is not, see "Jacket Filling" in the "Preventive Maintenance" section of this manual.
- c. Keep the primary air shutter of the burner gas jets free of dust and lint.
- d. The pilot flame should be blue and should envelop about ½ inch of the flame sensor tip.
- e. Keep electrical wiring and connections in good condition.
- f. Keep the inside of the control console clean and dry.
- g. Keep the burner ports clean.
- h. Keep the burner shield and adjacent parts clean.
- i. Twice a month, check the safety valve to make sure that it works freely. When gauge pressure is about 5 PSI, lift the valve lever enough to vent steam, then quickly let it snap back into place.

2. Component Replacement

When replacement involves breaking a gas pipe connection, check the new connection with soap solution or other appropriate leak detector.

DO NOT USE A FLAME TO TEST FOR LEAKS. Internal wiring is marked as shown on circuit schematic drawings. Be sure that new components are wired in the same manner.

SEQUENCE OF OPERATION

The following "action-reaction" outline is provided to help service personnel understand how the unit functions for systematic troubleshooting and fault isolation.

When the operator turns the heat to "ON", electric power at 120V is supplied to the thermostat. The automatic gas control is then energized. Simultaneously, an electric arc is established at the spark gap, and the automatic valve for the pilot burner opens. When the electric spark ignites gas flowing from the pilot burner, a pilot flame probe detects the flame. The probe sends a control signal that causes the spark to shut off and a circuit to close for 24 V power.

The 24 V provides power for the heating indicator light and the main automatic valve. Gas flowing from the main burner is ignited by the pilot flame. If a pilot flame is not sensed within 60 seconds after the spark, a timer shuts down the whole operation.

As heat from the main burner brings the temperature of steam in the jacket up to the thermostat setting, the thermostat switch opens. With electric power cut off, the main burner valve closes and turns off the burner. When jacket steam cools below the thermostat set point, the thermostat switch closes and begins another heating cycle. On-off cycling continues to maintain the kettle at the desired temperature.

The thermostat controls heating by alternately calling for flames at the full capacity of the main burner or signaling the control to shut the burner completely off. Because the control works in this "all or nothing" way, the kettle will heat as fast as it can until it reaches the set temperature, no matter what that temperature is. Turning the thermostat dial to a higher setting will cause heating to continue longer, until the kettle reaches the higher temperature, but it cannot make the unit heat any faster.

The unit is equipped with a Pressure Limit Switch, Low Water Cut-Off and a Safety Valve. These safety features operate as follows:

1. Pressure limit switch: If jacket steam pressure exceeds 43 PSI, the switch opens and breaks the electrical circuit to the main gas valve solenoid coil. The valve closes and stays closed until jacket pressure decreases to 44 PSI. The pressure limit switch then closes, energizes the gas valve coil, and allows operation to resume.
2. Low-water cutoff: As long as steam jacket water touches the cutoff electrode, kettle operation can continue. If the water falls below the end of the electrode, an electrical control circuit is broken, and the main gas valve closes. Jacket water must be restored to a safe operating level before the kettle can be heated again.
3. Safety valve: If steam pressure in the jacket reaches 50 PSI, the valve will open and relieve the excess pressure.

TROUBLESHOOTING

Your kettle is designed to operate smoothly and efficiently if properly maintained. However, the following is a list of checks to make in the event of a problem. Wiring diagrams are furnished inside the service panel. X indicates items which must be performed by an authorized technician.

WARNING: BEFORE REPLACING ANY PARTS, DISCONNECT THE UNIT FROM THE ELECTRIC POWER SUPPLY AND CLOSE THE MAIN GAS VALVE. ALLOW FIVE MINUTES FOR UNBURNED GAS TO VENT.

CAUTION: USE OF ANY REPLACEMENT PARTS OTHER THAN THOSE SUPPLIED BY GROEN OR THEIR AUTHORIZED DISTRIBUTOR CAN CAUSE INJURY TO THE OPERATOR AND DAMAGE TO THE EQUIPMENT AND WILL VOID ALL WARRANTIES.

SYMPTOM	WHO	WHAT TO CHECK
Kettle continues heating after it reaches desired temperature.	User	a. That the temperature controller is correct.
Kettle stops heating before it reaches the desired temperature.	User	a. That the temperature controller setting is correct. b. That the Heat on/off switch is ON. c. Reading of the pressure/vacuum gauge. If it is not 20 to 30 below zero when the kettle is cold, see "Jacket Vacuum" in the "Preventive Maintenance" section of this manual.
Pilot burner and/or burner will not light or goes out after working for a while.	User	a. That the main gas valve is open (handle is in line with the gas pipe) b. That the Heat on/off switch is ON. c. That the temperature controller is at the correct setting. d. Use the "Start Kettle Procedure." See the manual's "Operation" Section. e. Jacket water level. If it is low, see "Jacket Filling" in the "Preventive Maintenance" section of this manual. f. That electric power is turned on at the circuit breaker or fuse box, and that power is being supplied to your building. g. Gas supply to your building. h. Is steam trap working?
Kettle heats slowly.	User	a. Reading of the pressure/vacuum gauge. If not 20 to 30 below zero when the kettle is cold, see "Jacket Vacuum" in the "Preventive Maintenance" section of this manual.
	Authorized Service Rep Only	b. Check operation of pressure limit switch. X
Safety valve pops.	User	a. Reading of the pressure/vacuum gauge. If it is not 20 to 30 below zero when the kettle is cold, see "Jacket Vacuum" in the "Preventive Maintenance" section of this manual.
System does not produce a spark.	Authorized Service Rep Only	a. Thermostat, and close the contacts if they are open. X b. AC voltage between terminals "2" and "GR". If it is not 24 Volt: (1) Check high limit switch, which should be closed. X (2) Replace the transformer. X c. Pilot spark gap. Regap, if it is not 7/64 inch. X d. Pilot electric ceramic for crack or break. X e. That the high tension cable is firmly attached and in good condition. If cracked or brittle, replace the pilot. X f. Replace the electronic portion of the G60 electronic system. X
Spark is present but the pilot will not light.	Authorized Service Rep Only	a. That the pilot valve is securely connected to terminals "1" and "GR". Some models have the pilot valve grounded internally. X b. That gas pressure meets the control manufacturer's specifications. X c. For gas at the pilot. If it is not flowing: (1) Check the pilot gas line for kinks and obstructions. X (2) Replace the pilot valve. X d. That the pilot spark gap is 7/64 inch and located in the pilot gas stream. If not, adjust or replace the pilot. X e. Pilot orifice, and clean, if necessary. X f. For drafts. Shield the pilot burner, if necessary. X
Pilot lights, but main burner will not come on, and spark does not stay on.	Authorized Service Rep Only	a. For 24 V between terminals "3" and "GR". If voltage is not correct, replace the G60 electronics. X b. That the gas pressure meets the control manufacturer's specifications. X c. Electrical connections to the main valve to terminals "3" and "GR", to assure that they are securely attached. If they are, replace the main valve."

<p>Pilot lights, but main burner will not come on, the spark stays on.</p>	<p>Authorized Service Rep Only</p>	<ul style="list-style-type: none"> a. Sensor cable, to make sure of secure and attachments to the sensor and to terminal "4" the G60. X b. That the cable is not grounded. If it is, correct the ground fault. X c. Cable for continuity and insulation condition. X d. Sensor ceramic for cracks. X e. That sensor probe current is less than 0.7 microamp, by disconnecting the sensor cable from terminal "4" and connecting a DC microammeter between the sensor cable terminal and terminal "4". If the current is equal to or greater than 0.7 microamp, replace the G60 electronics. X If the current is less than 0.7 microamp: <ul style="list-style-type: none"> (1) Check the gas pressure. X (2) Clean the pilot assembly. X (3) Tighten mechanical and electrical connections. X f. Pilot application and correct to increase sensor probe current, by: <ul style="list-style-type: none"> (1) Increasing or decreasing pilot orifice size. X (2) Shielding the pilot from drafts. X
--	------------------------------------	--

172194

KETTLE BODY ASSEMBLY

CALL FACTORY FOR REPLACEMENT PARTS:
888-994-7636

Parts List

Location	Function or Connection
A	LEFT TRUNNION
B	RIGHT TRUNNION
C	POUR LIP
D	WELL AND COUPLING FOR RTD
E	WATER LEVEL SIGHT GLASS
F	HEAT EXCHANGE FIN-TUBES
G	COUPLING FOR WATER LEVEL PROBE
H	COUPLING FOR TEMPERATURE PROBE
I	ASME DATA PLATE

Ref	Description	Part #
-	LABEL, DISTILLED WATER	Z026450
-	PROBE, TEMPERATURE, 6" LONG	115369
-	VALVE, SAFETY, 50 PSI, 3/4 NPT	Z005587
-	ASSEMBLY, WATER FILL	115372
-	ELBOW, 90 DEGREE, 3/4 NPT	Z010668
-	ASSEMBLY, PLATE & CHAIN	Z8832
-	ASSEMBLY, FAUCET BRACKET & SPOUT	115247
-	FLUE STACK/COMBUSTION CHAMBER ASSEMBLY	149665

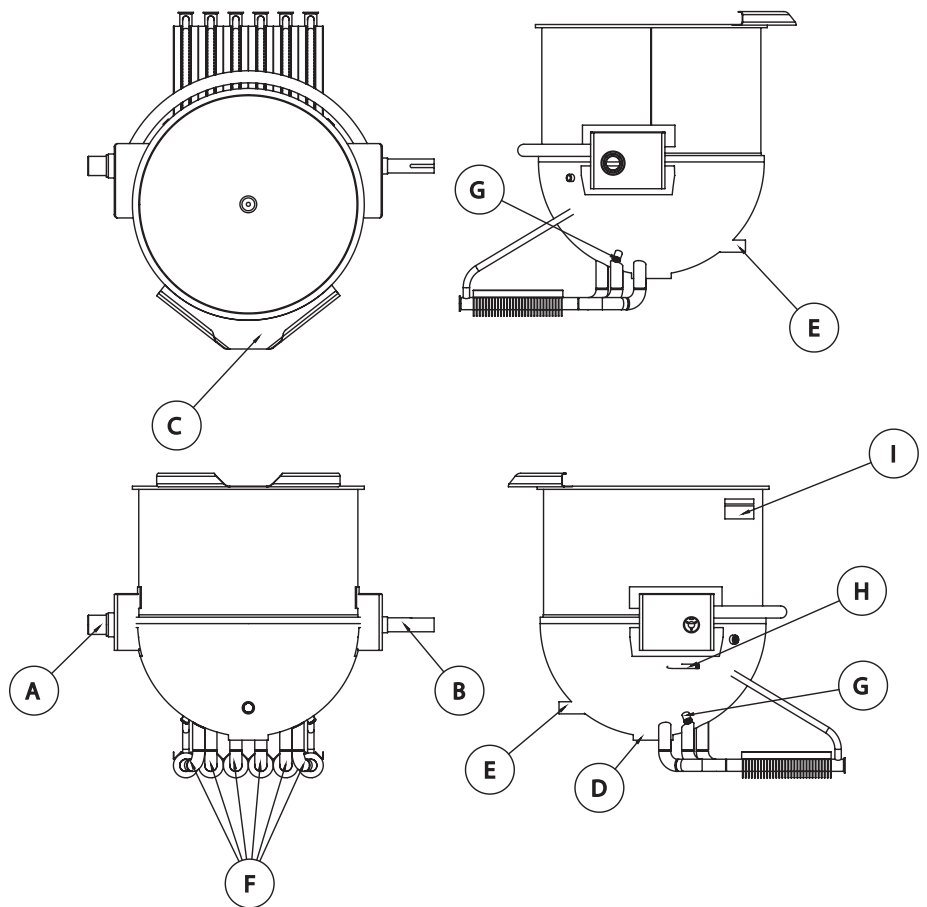

172278

LEFT STANCHION ASSEMBLY

CALL FACTORY FOR REPLACEMENT PARTS:

888-994-7636

Parts List

Ref	Description	Part #
1	NIPPLE, 1 NPT, 7" LONG	Z002490
2	NIPPLE, 1 NPT, 21" LONG	Z014018
3	ELBOW, 90 DEGREE, 1" NPT	Z010006
4	ELBOW, 90 DEGREE, 3/4 NPT, SS	Z009802
5	NIPPLE, 3/4 NPT, 6-1/2" LONG, SS	Z006230
6	HOSE, WATER FILLER	172466
7	ADAPTER, SWIVEL, 3/4 NPT, SS	115284
8	ADAPTER, 3/4 NPT, SS	115283
9	ASSEMBLY, WATER PIPING	172474
10	NIPPLE, 1 NPT, 15-1/2" LONG	Z014019
11	JOINT, SWIVEL, 1 NPT, (GAS)	115275
12	COUPLING, FULL, 1 NPT	Z010230
13	BLOCK, PILLOW	115225
14	BEARING, BRONZE	115268
16	NUT, HEX, KEPS, 1/4-20	Z012940
17	SCREW, HEX HEAD, 1/2-13, 2" LONG	Z083944
18	NUT, HEX, 1/2-13	Z003565
19	SCREW, SET, CUP POINT, 3/8-16, 5/8" LONG	Z012060
20	SET COLLAR, 3" TRUNNION	115239
21	FITTING, GREASE, STRAIGHT, 1/4 NPT	Z009547
22	NIPPLE, 3/4 NPT, 12" LONG	133409
23	COUPLING, FULL, 1 NPT	Z010230
24	SCREW, TRUSS HEAD, 10-32, 1/2" LONG	Z072189
25	COVER, STANCHION, LEFT SIDE	172383
26	ASSEMBLY, INNER CLADDING, STANCHION, LEFT SIDE	172267
27	LABEL, NATURAL GAS	Z087993
27	LABEL, PROPANE GAS	Z087992
28	ASSEMBLY, OUTER CLADDING, STANCHION, LEFT SIDE	172265
29	GASKET, 1/16 X 1, NEOPRENE, CLOSED CELL, 7' LONG	115336
30	ASSEMBLY, FRAME, LEFT STANCHION	172360
31	LABEL, WATER IN	Z040232
32	ASSEMBLY, FRAME, POWER COVER	172366
33	GASKET, NEOPRENE, 9-1/2 X 9-1/2, FRAME TOP	172365
35	NIPPLE, CLOSE, 1 NPT	Z005517
36	ASSEMBLY, FRAME, LEFT SIDE	172360
-	BOLT, HEX, 3/8-16, 1-1/4" LONG	FA BLT0101
-	NUT, HEX, 3/8-16	FA NUT0341
-	WASHER, FLAT, 3/8	Z005830
40	SWITCH, EMERGENCY STOP	N87527
-	WASHER, LEVELING	172280
42	BRACKET, KETTLE SHROUD	115310
-	NUT, ACORN, 1/4-20	Z090567
44	OVERLAY, EMERGENCY STOP	115317A

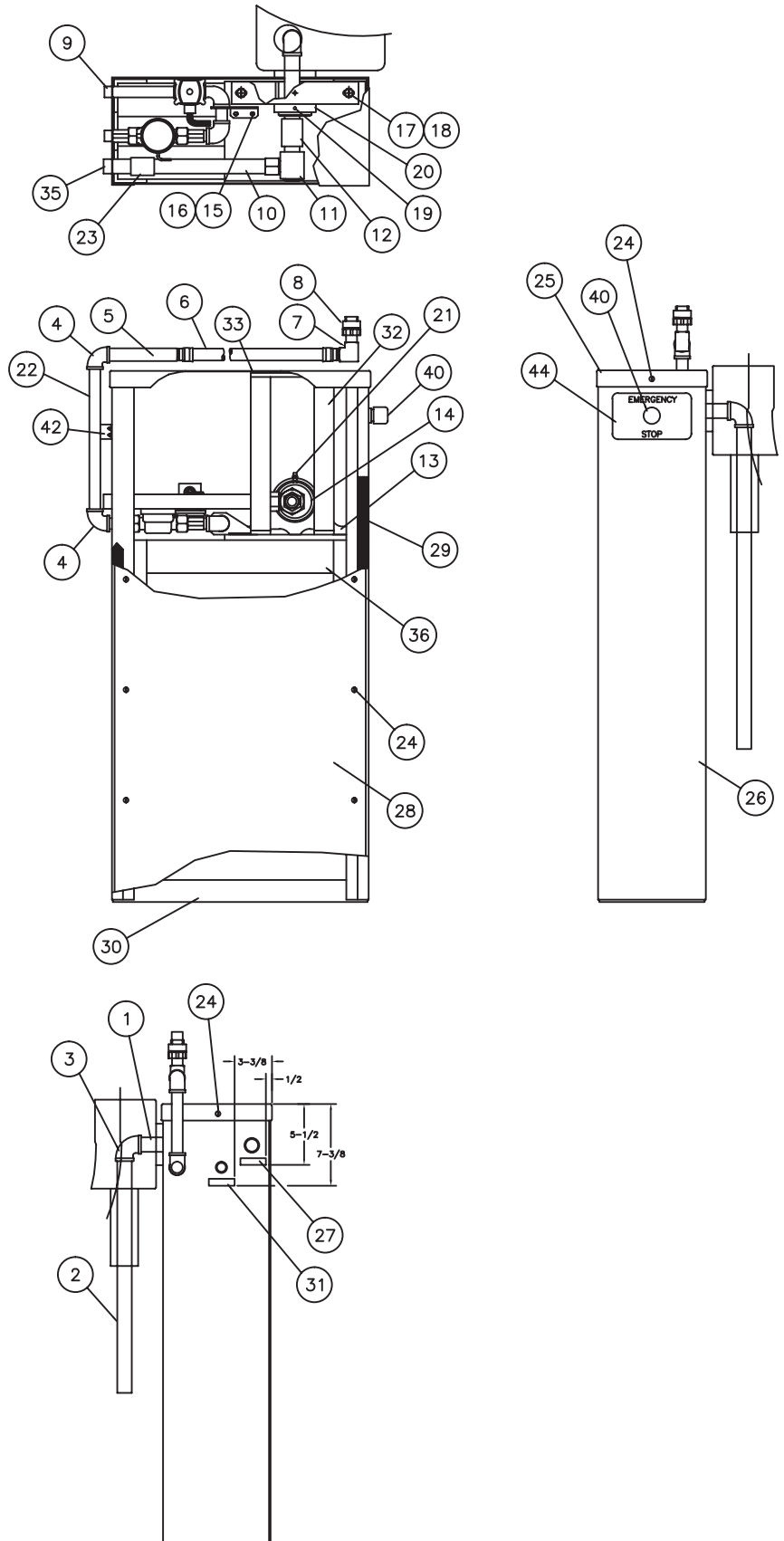

172474

WATER PIPING ASSEMBLY

CALL FACTORY FOR REPLACEMENT PARTS:
888-994-7636

Parts List

Ref	Description	Part #
1	ELBOW, STREET, 90 DEGREE, 3/4 NPT, SS	172471
2	ELBOW, 90 DEGREE, 3/4 NPT, SS	172473
3	NIPPLE, 3/4 NPT, 2" LONG, SS	172472
4	NIPPLE, 3/4 NPT, 4" LONG, SS	172470
5	METER, WATER, (MEASURES IN GALLONS)	Z055211
5	METER, WATER, (MEASURES IN LITERS)	Z098369
6	VALVE, SOLENOID, WATER, 24VDC	172475

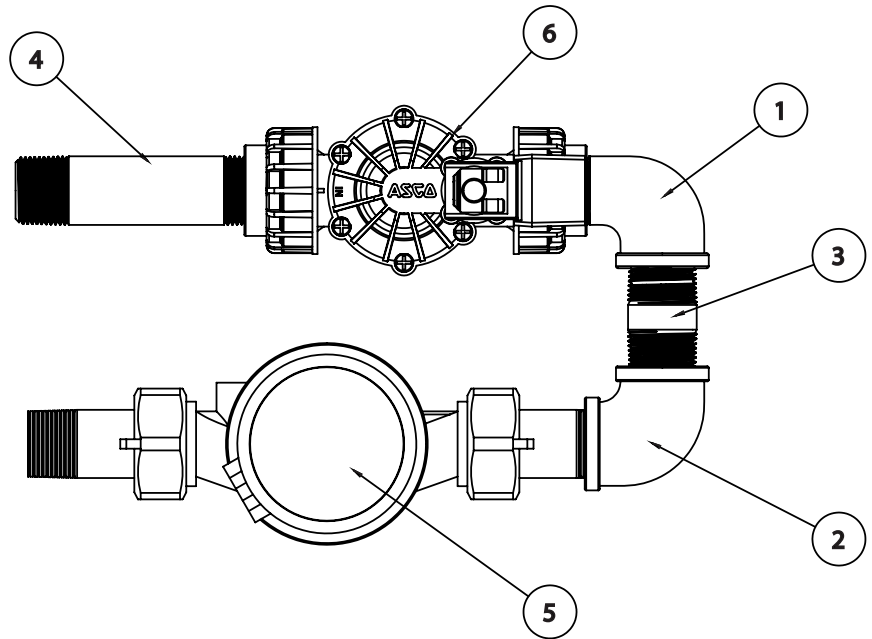

**172378
GAS VALVE PIPING, PRESSURE GAUGE
AND BOX ASSEMBLY**

**CALL FACTORY FOR REPLACEMENT PARTS:
888-994-7636**

Parts List

Ref	Description	Part #
1	GASKET, CLOSED CELL, NEOPRENE	115336
2	CAP, PROBE, WATER LEVEL	115319B
3	FITTING, PROBE, WATER LEVEL	146992
4	ASSEMBLY, PIPING, GAS	149650
6	COVER, ENCLOSURE, GAS VALVE	115294
7	SCREW, TRUSS HEAD, 10-32 X 1/2" LONG	Z072189
8	NUX, HEX, 8-32	Z011030
9	SCREW, CAP, HEX HEAD, 1/4-20 X 1/2" LONG	Z005608
10	NUT, HEX, 1/4-20	Z005601
11	COVER, ENCLOSURE, WATER LEVEL	115290
13	ENCLOSURE, WATER LEVEL	172377
14	ASSEMBLY, PIPING, PRESSURE SWITCH & GAUGE	172376
15	UNION, 3/8 NPT	Z027421
16	GROMMET, 11/16 ID	Z007245
17	GROMMET, 9/16 ID	Z074974
18	GROMMET, 7/8 ID	Z007400
19	GROMMET, 1/4 ID	Z001518
20	GROMMET, STRAIN RELIEF	Z088239
22	LIGHT, INDICATOR, RED, 24VAC	116383
23	OVERLAY, OPERATING PRESSURE	115317D
25	GRIP, CORD, 1/2 NPT	Z009196
26	FITTING, COMPRESSION, STRAIGHT, 3/8 NPT - 3/8 TUBE	117801
27	FITTING, COMPRESSION, 90 DEGREE, 3/8 NPT - 3/8 TUBE	117802
28	TUBING, COPPER, 3/8 OD, 12" LONG	Z007332
29	CONNECTOR, 90 DEGREES, 1/2 NPT	Z001668
30	PROBE, WATER LEVEL	Z076526
31	MODULE, IGNITION, INTERMITTENT PILOT	Z085153
32	CONDUIT, GAS PIPING	115234
33	GASKET, CONDUIT	115299
34	RIVNUT, OPEN END, 10-32	113235
-	CONDUIT, SEALTITE, 1/2"	Z001697
37	TUBING, ALUMINUM, 1/4 OD, 36" LONG	Z006796
38	CABLE, HIGH VOLTAGE, IGNITION, 36" LONG	Z096728
39	WIRE HARNESS, MAIN	115335
40	NUT, CONDUIT, 1/2 NPT	Z008808
41	ENCLOSURE, GAS VALVE	115292
-	GROMMET, SILICONE, 11/16 ID	128863
-	TEE, 1/2 NPT	Z013650
-	NIPPLE, CLOSE, 1/2 NPT	Z004306
48	COUPLING, 1/2 RECESSED, 1/4 NPT	Z004158

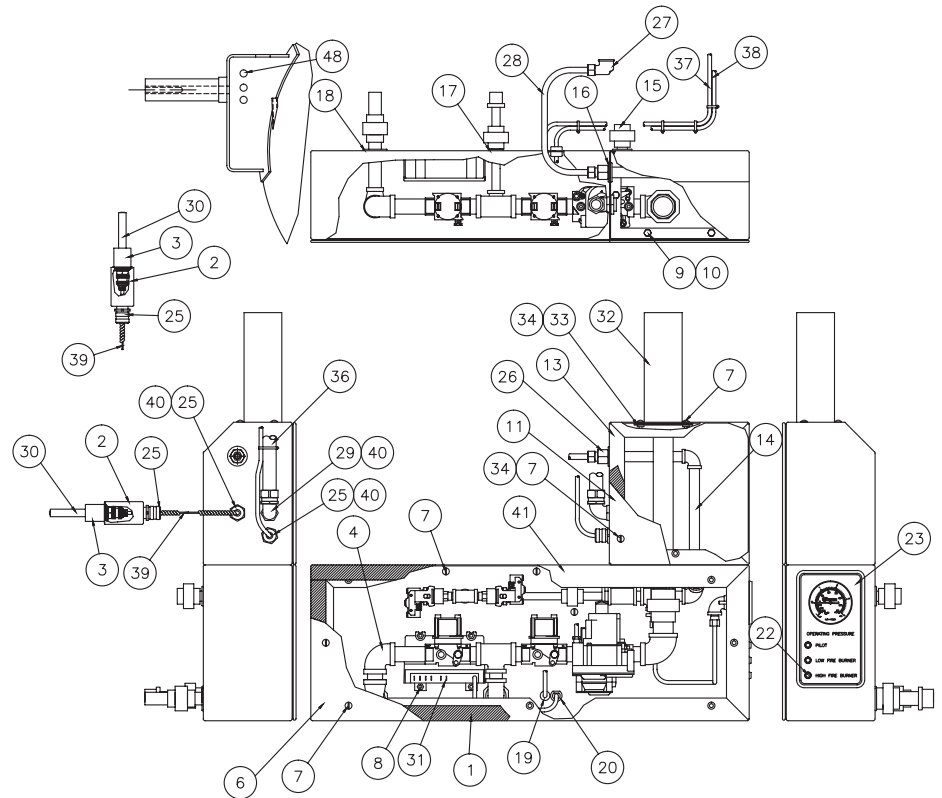

**172376
PRESSURE SWITCH AND GAUGE
PIPING ASSEMBLY**

**CALL FACTORY FOR REPLACEMENT PARTS:
888-994-7636**

Parts List

Ref	Description	Part #
1	PRESSURE SWITCH, SET AT 43 PSI	Z096963
2	TEE, 1/4 NPT	Z008539
3	PRESSURE SWITCH, SET AT 43 PSI	Z096963
4	ELBOW, 90 DEGREE, 1/4 NPT	Z005682
5	NIPPLE, 1/4 NPT, 1" LONG	Z005683
6	NIPPLE, 1/4 NPT, 6-1/2" LONG	Z003674
7	UNION, STRAIGHT, 1/4 NPT	Z005126
8	NIPPLE, 1/4 NPT, 2" LONG	Z005675
9	BUSHING, REDUCING, 3/8 NPT - 1/4 NPT	Z059907
10	TEE, 3/8 NPT	Z012794
11	NIPPLE, 3/8 NPT, 10" LONG	Z012794
12	ELBOW, STREET, 90 DEGREE, 3/8 NPT	Z009853
13	NIPPLE, 3/8 NPT, 6" LOG	Z005752
17	ELBOW, 90 DEGREE, 3/8 NPT	Z055335
18	GAUGE, PRESSURE	115293
19	FITING, STRAIGHT, COMPRESSION, 1/4 NPT - 1/4 TUBE	Z064565
20	NIPPLE, 3/8 NPT, 1-1/2" LONG	Z005678
21	NIPPLE, 3/8 NPT, 1" LONG	Z007439
22	TUBING, COPPER, 1/4, 24" LONG	116002
	NIPPLE, 3/8 NPT, 4" LONG	Z005720

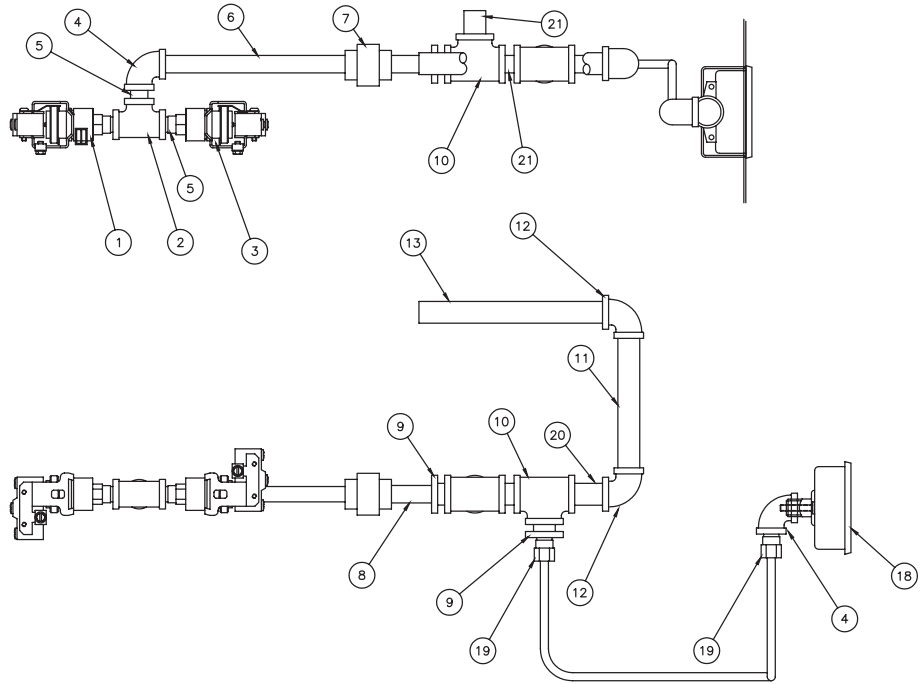

149650
GAS VALVE PIPING ASSEMBLY
CALL FACTORY FOR REPLACEMENT PARTS:
888-994-7636

Parts List

Ref	Description	Part #
1	UNION, STRAIGHT, 1 NPT	Z005534
2	NIPPLE, CLOSE, 1 NPT	Z005517
3	ELBOW, REDUCING, 1 NPT X 3/4 NPT	Z003610
4	VALVE, GAS, MAIN	115298
5	NIPPLE, CLOSE, 3/4 NPT	Z008238
6	VALVE, GAS, SOLENOID, 3/4 NPT	108963
7	TEE, REDUCING, 3/4 NPT X 3/4 NPT X 1/2 NPT	Z005484
8	NIPPLE, 3/4 NPT, 4" LONG	Z005554
9	ELBOW, 3/4 NPT	Z008124
10	ELBOW, REDUCING, 3/4 NPT X 1/2 NPT	Z008751
11	NIPPLE, 1/2 NPT, 4" LONG	Z005554
12	UNION, STRAIGHT, 1/2 NPT	Z004186
13	NIPPLE, 1/2 NPT, 2" LONG	Z005551
14	BUSHING, REDUCING, 1/2 NPT X 1/4 NPT	Z008739
15	NIPPLE, 1/4 NPT, 2" LONG	Z005675
16	UNION, STRAIGHT, 1/4 NPT	Z005126
17	NIPPLE, 1/4 NPT, 3-1/2" LONG	Z041509
18	ELBOW, 90 DEGREE, 1/2 NPT	Z008747
19	NIPPLE, 1/2 NPT, 1-1/2" LONG	Z004184

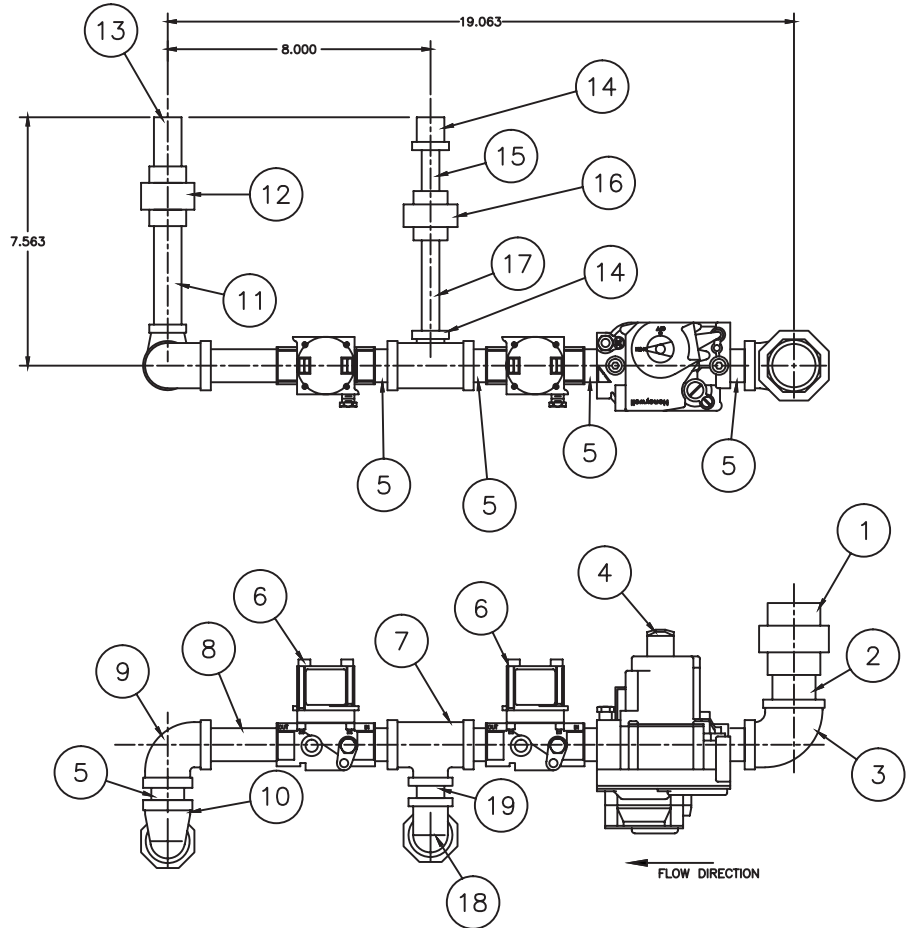

172361
RIGHT STANCHION ASSEMBLY
CALL FACTORY FOR REPLACEMENT PARTS:
888-994-7636

Parts List

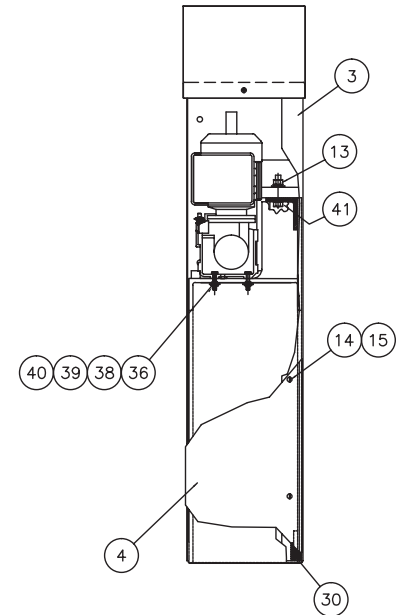
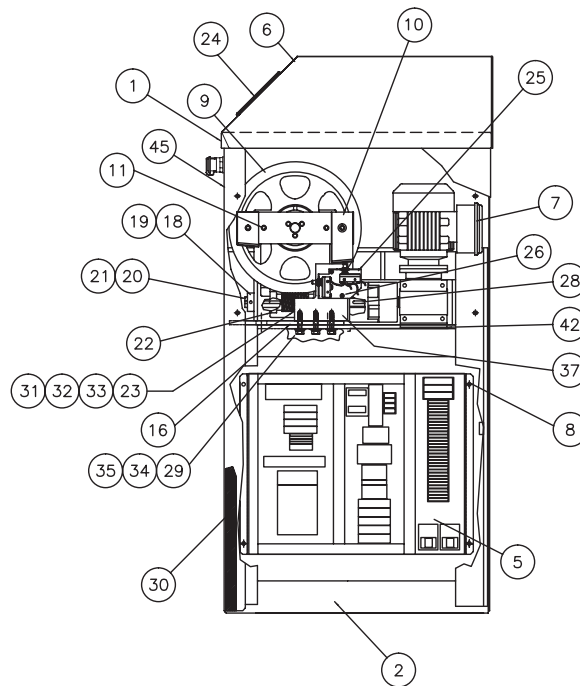
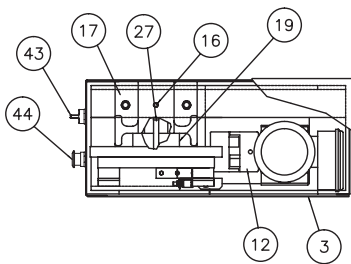

Ref	Description	Part #
1	COVER, STANCHION, RIGHT SIDE	172384
2	ASSEMBLY, FRAME, RIGHT STANCHION	172293
3	ASSEMBLY, OUTER CLADDING, STANCHION, RIGHT SIDE	172265
4	ASSEMBLY, INSIDE CLADDING, STANCHION, RIGHT SIDE	172294
5	SUBASSEMBLY, ELECTRICAL COMPONENTS	172393
6	ASSEMBLY, ENCLOSURE, CONTROL PANEL	172390
7	MOTOR, DRIVE, 1/2 HP	128973
8	NUT, HEX, KEPS, 1/4-20	NT1101
9	GEAR, 72 TOOTH	115269
10	ASSEMBLY, MECHANICAL STOP	115240
11	SCREW, CAP, SOCKET, 5/16-18, 2" LONG	115302
12	COUPLING, SHAFT	115276
13	NUT, HEX 1/2-13	Z003565
14	RIVNUT, OPEN END, 10-32	113235
15	SCREW, TRUSS HEAD, 10-32, 1/2" LONG	Z072189

Ref	Description	Part #
16	FITTING, GREASE, STRAIGHT, 1/4 NPT	Z009547
17	CASTING, TRUNNION GEAR CARRIER	Z012222
18	COLLAR, SET, 1" ID	Z012012
19	SCREW, SET, CUP POINT, 3/8-16, 5/8" LONG	Z012060
20	SHAFT, DRIVE	115242
21	KEY, 1/4" SQUARE, 3-1/4" LONG	Z012468
22	BEARING, ROLLER, 1"	Z012036
23	GEAR, WORM	Z012054
24	HMI, TOUCH SCREEN CONTROLLER	172292
25	ASSEMBLY, TILT SWITCH & HARNESS	115282
26	SCREW, TRUSS HEAD, 8-32, 3/8" LONG	Z005764
27	BAR, 1/2" SQUARE, SS, 3-1/2" LONG	303208
28	KEY, 1/4" SQUARE, 2" LONG	Z009258
29	SCREW, CAP, HEX, 3/8-16, 1-1/2" LONG	Z005615
30	GASKET, NEOPRENE, CLOSED CELL, 90-INCHES	115336

Ref	Description	Part #
31	WASHER, SHIM, 1-3/4 OD, 0.001" THICK	Z012192
32	WASHER, SHIM, 1-3/4 OD, 0.003" THICK	Z012193
33	WASHER, SHIM, 1-3/4 OD, 0.005" THICK	Z012079
34	WASHER, FLAT, 3/8, SS	Z005830
35	WASHER, LOCK, SPLIT, 3/8	Z005618
36	NUT, HEX, 5/16-18	Z005602
37	BLOCK, STOP, MECHANICAL	115213
38	SCREW, SAP, HEX HEAD, 5/16-18, 1-1/2" LONG	Z006017
39	WASHER, FLAT, 5/16	Z012093
40	WASHER, LOCK, 5/16	Z005658
41	SCREW, CAP, HEX HEAD, 1/2-13, 2-1/2" LONG	Z005629
42	PLATE, SHIP, TILT MOTOR	172272
43	ASSEMBLY, SWITCH, 2 POSITION	115337A
44	SWITCH, EMERGENCY STOP	N87527
45	OVERLAY, POWER AND EMERGENCY STOP	172398

172476
ELECTRICAL SUB PANEL ASSEMBLY
 CALL FACTORY FOR REPLACEMENT PARTS:
 888-994-7636

Parts List

Ref	Description	Part #
1	PLC, 1763-L16DWD	172520
2	ANALOG OUTPUT, 1762-IR4	172521
3	ETHERNET SWITCH, EKI-2525 AE 5 PORT	172522
4	24 VDC POWER SUPPLY, MDR-120-24	172523
5	3A CIRCUIT BREAKER, FAZ-C3/2-NA UL 489 3A	172524
6	1A CIRCUIT BREAKER, FAZ-C1/1SP UL 1077 1A	172525
7	2A CIRCUIT BREAKER, FAZ-C2/1SP UL 1077 2A	172526
8	5A CIRCUIT BREAKER, FAZ-C5/1SP UL 1077 5A	172527
9	75 VA TRANSFORMER, PH75MLI 75VA	172528
10	1.5A FUSE, ATDR1.5	172529
11	10A FUSE, ATMR10	172530
12	FUSE HOLDER, US3J31	172531
13	CONTACTOR, MC-9B-DC24-11S	172532
14	CONTACTOR, MC-9B/R-DC24-22S	172533
15	ON / OFF CONTROL WITH LOCKOUT, MMS-32H-2.5 BRK/OL	172534
16	RELAY, AB 700-HLT12U24	172535
19	TERMINAL, 1492-J3-W 600VOLT 25 AMP	172536
20	TERMINAL, 1492-JG3-IEC 600VOLT GND	172537
21	LOW WATER CUTOFF, PN 26B3B	172538
-	PANEL, ELECTRICAL MOUNT	172296
-	NUT, HEX, 1/4-20	Z005601

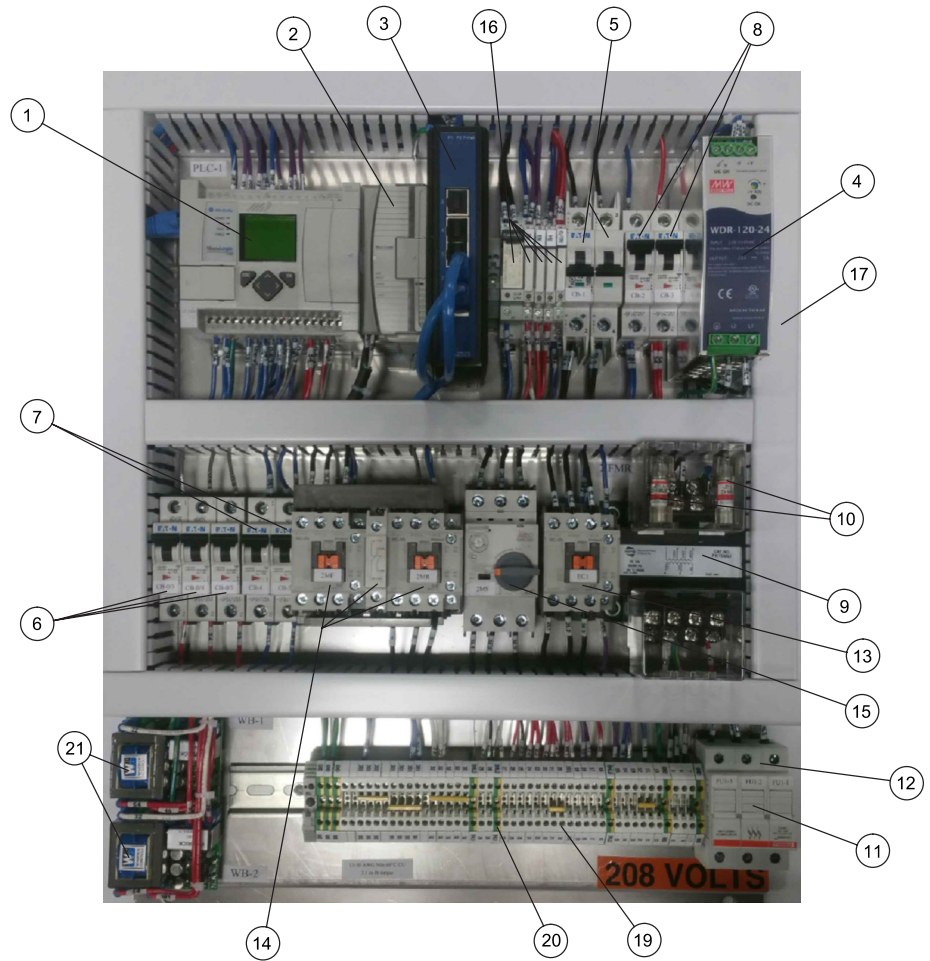

115282
TILT SWITCH ASSEMBLY
CALL FACTORY FOR REPLACEMENT PARTS:
888-994-7636

Parts List

Ref	Description	Part #
1	SWITCH, OVERTRAVEL, PLUNGER TYPE	115261
2	BRACKET, TILT SWITCH	115221
3	HARNESS, TILT SWITCH	115281

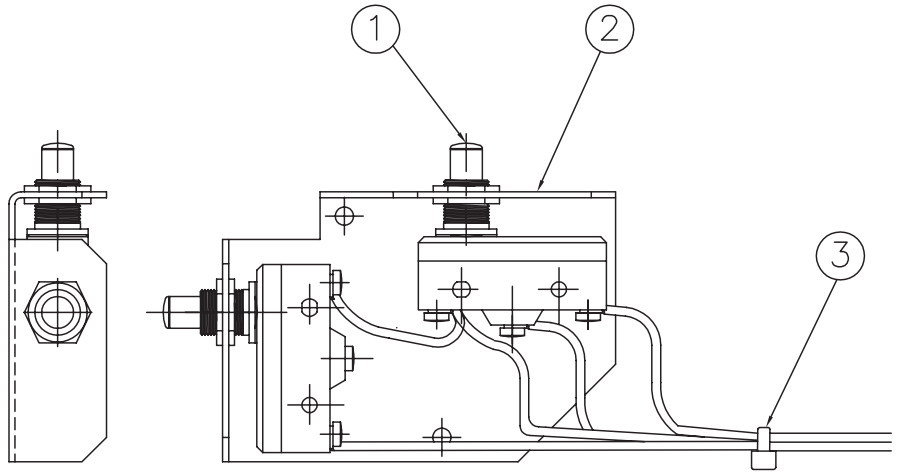
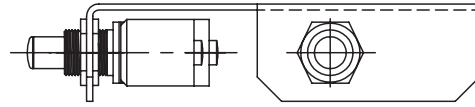

HIGH FIRE BURNER ASSEMBLY
CALL FACTORY FOR REPLACEMENT PARTS:
888-994-7636

Parts List

Ref	Description	Part #
1	MANIFOLD, BURNER, 40-PORT	146985
2	NIPPLE, 1/2 NPT, 3-1/2" LONG	Z008227
3	BUSHING, REDUCING, 1/2 NPT TO 1/8 NPT	Z088290
4	BURNER JET, BRASS, 7/16-24 NS, #654	SEE ELEVATION TABLE
5	PLUG, PIPE, RECESSED HEX, 1/8 NPT	Z010286

Ref	BURNER JETS, BRASS, 7/16-24 NS Elevation - Jet Orifice Size	Part #
NATURAL GAS		
N02	0-2000' ELEVATION -- 1.15MM (0.0453)	127554
N24	2001-4000' ELEVATION -- 1.05MM (0.0413)	106159
N46	4001-6000' ELEVATION -- 1.05MM (0.0394)	127560
N68	6001-8000' ELEVATION -- 0.95MM (0.0374)	174293
N810	8001-10000' ELEVATION -- 0.89MM (0.0350)	127361
LP GAS		
L02	0-2000' ELEVATION -- 0.79MM (0.0310)	102944
L24	2001-4000' ELEVATION -- 0.71MM (0.0280)	127563
L46	4001-6000' ELEVATION -- 0.70MM (0.0276)	174292
L68	6001-8000' ELEVATION -- 0.65MM (0.0256)	154178
L810	8001-10000' ELEVATION -- 0.61MM (0.0240)	104291

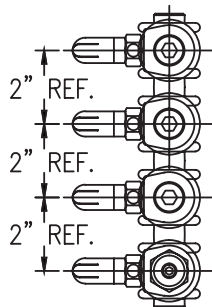
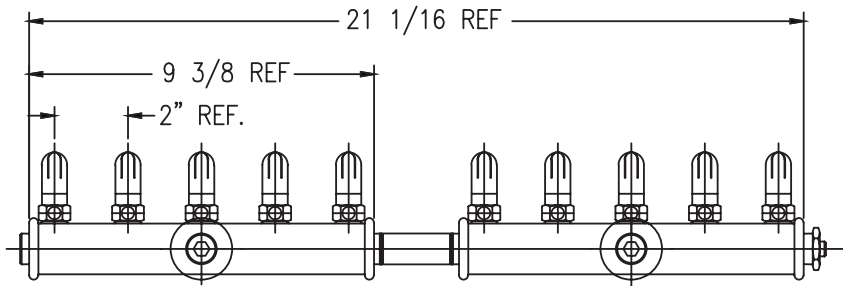
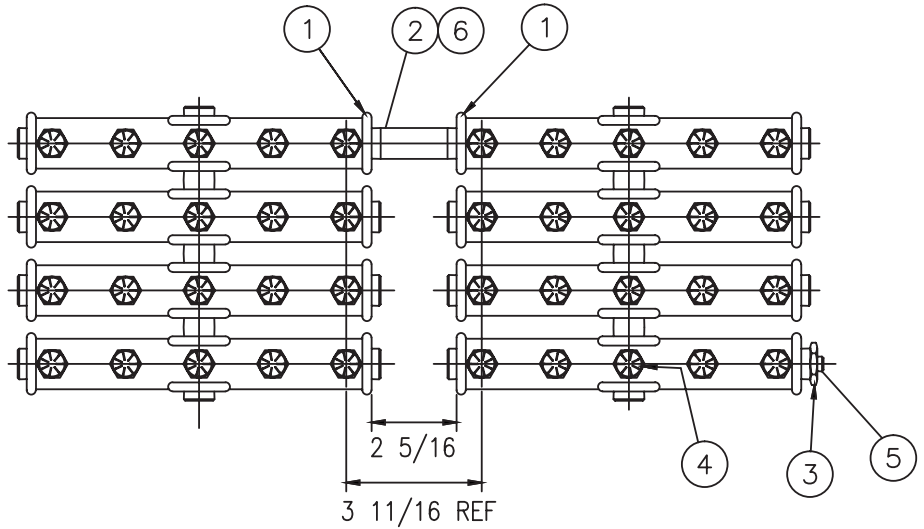

LOW FIRE BURNER ASSEMBLY
CALL FACTORY FOR REPLACEMENT PARTS:
888-994-7636

Parts List

Ref	Description	Part #
1	MANIFOLD, BURNER, 20-PORT	146986
2	NIPPLE, 1/2 NPT, 3-1/2" LONG	Z008227
3	BUSHING, REDUCING, 1/2 NPT TO 1/8 NPT	Z088290
4	NIPPLE, 1/2 NPT, 1-1/2" LONG	Z004184
5	BURNER JET, BRASS, 7/16-24 NS, #654	SEE ELEVATION TABLE
6	PLUG, PIPE, RECESSED HEX, 1/8 NPT	Z010286

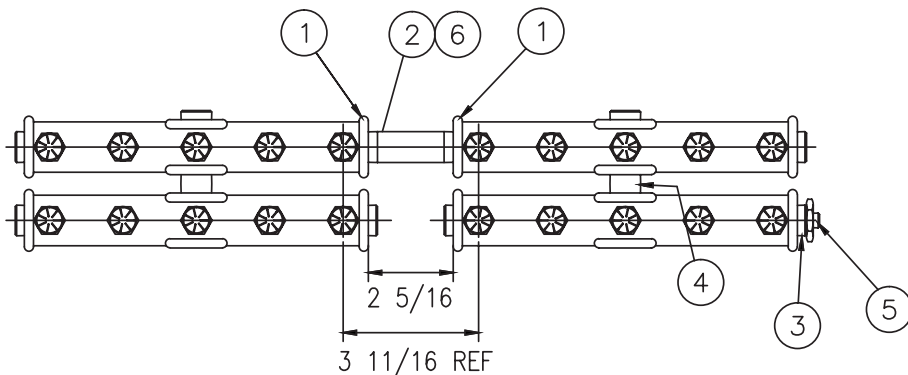

Ref	BURNER JETS, BRASS, 7/16-24 NS Elevation - Jet Orifice Size	Part #
NATURAL GAS		
N02	0-2000' ELEVATION -- 1.15MM (0.0453)	127554
N24	2001-4000' ELEVATION -- 1.05MM (0.0413)	106159
N46	4001-6000' ELEVATION -- 1.05MM (0.0394)	127560
N68	6001-8000' ELEVATION -- 0.95MM (0.0374)	174293
N810	8001-10000' ELEVATION -- 0.89MM (0.0350)	127361
LP GAS		
L02	0-2000' ELEVATION -- 0.79MM (0.0310)	102944
L24	2001-4000' ELEVATION -- 0.71MM (0.0280)	127563
L46	4001-6000' ELEVATION -- 0.70MM (0.0276)	174292
L68	6001-8000' ELEVATION -- 0.65MM (0.0256)	154178
L810	8001-10000' ELEVATION -- 0.61MM (0.0240)	104291

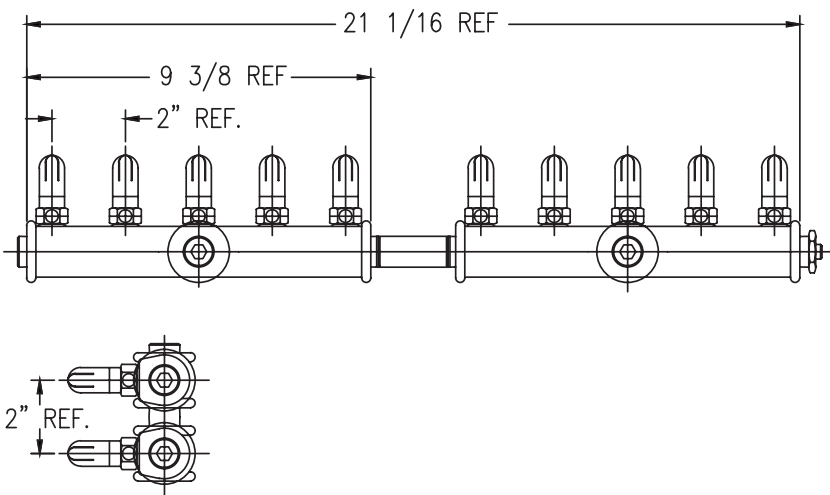

174301
DH/400L POWER-AID COVER KIT
 CALL FACTORY FOR REPLACEMENT PARTS:
 888-994-7636

Parts List

Ref	Description	Part #
1	ASSEMBLY, COVER	174301
2	ASSEMBLY, MOUNTING ARM, POWER AID	172372
3	ASSEMBLY, ACTUATOR, #51 POWER AID	159045
5	NUT, HEX, ACORN, 1/4-20 SS	FA NUT0403

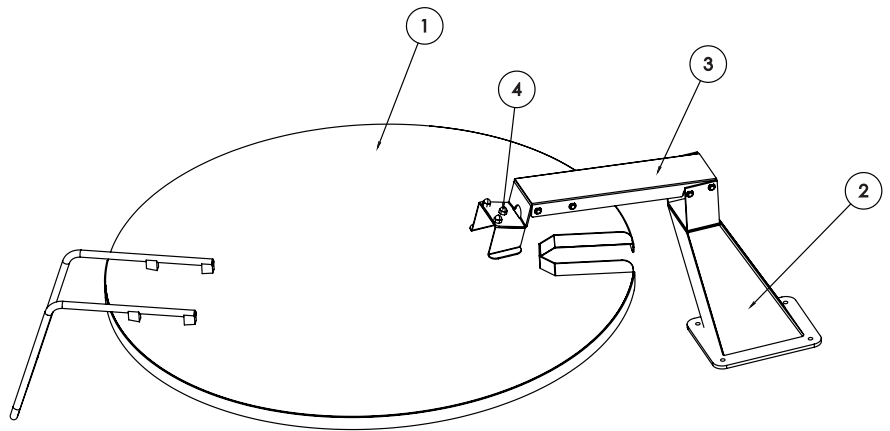

159045
#51 POWER AID ACTUATOR
 CALL FACTORY FOR REPLACEMENT PARTS:
 888-994-7636

Parts List

Ref	Description	Part #
1	ASSEMBLY, BRACKET HINGE	Z012813
2	BODY, ACTUATOR	Z002440
3	HOUSING, SPRING ASSEMBLY	Z012407
4	ROD, SPRING ASSEMBLY	Z012524
5	PIN, ACTUATOR HINGE	Z012526
6	PIN, ACTUATOR HINGE	Z012525
-	SPACER, 3/4 OD, 1-13/16" LONG	Z012527
8	SPACER, 3/4 OD, 5/8" LONG	Z012528
9	NUT, HEX, JAM	Z012538
10	RING, RETAINING, EXTERNAL	Z012529
-	WASHER, PLAIN, 1/2	Z005598
12	BRACKET, COVER	Z012531
13	WASHER, FENDER, 1/4	132107
14	NUT, LOCK, ACORN, 1/4-20	Z086431
16	SPRING, HIGH	Z012533

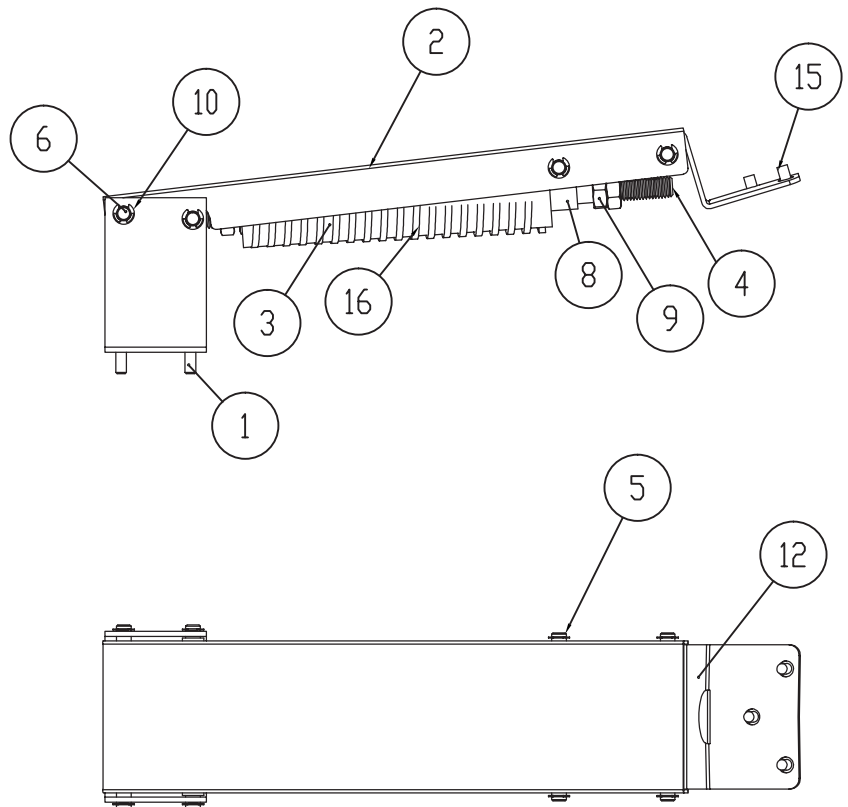

**115330
STRAINER AND FRAME
ASSEMBLY (OPTIONAL)**

**CALL FACTORY FOR REPLACEMENT PARTS:
888-994-7636**

Parts List

Ref	Description	Part #
1	ASSEMBLY, FRAME, STRAINER	115325
2	STRAINER	115324
3	LATCH, LEFT SIDE	115321A
4	LATCH, RIGHT SIDE	115321B
5	SCREW, TRUSS HEAD, 1/4-20, 1/2" LONG	Z012700

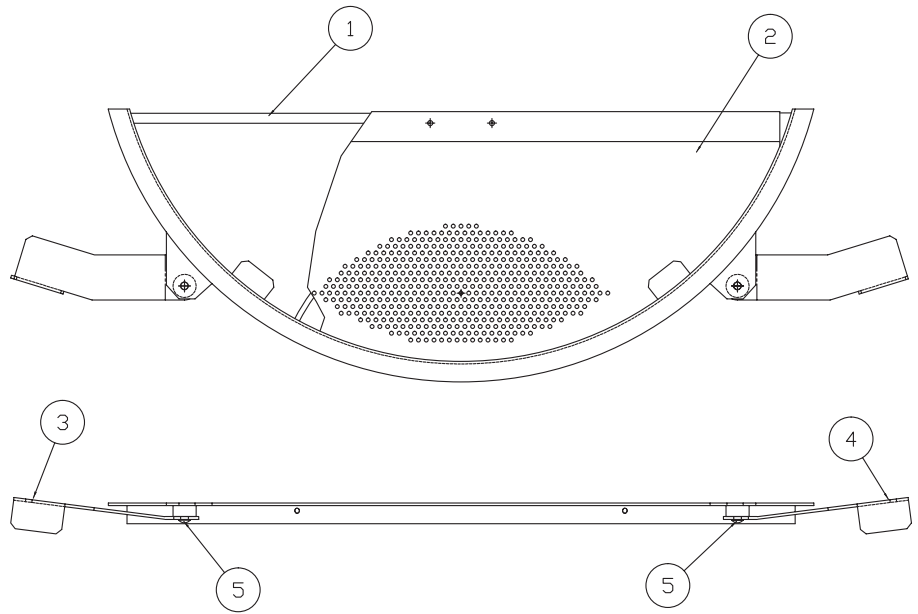

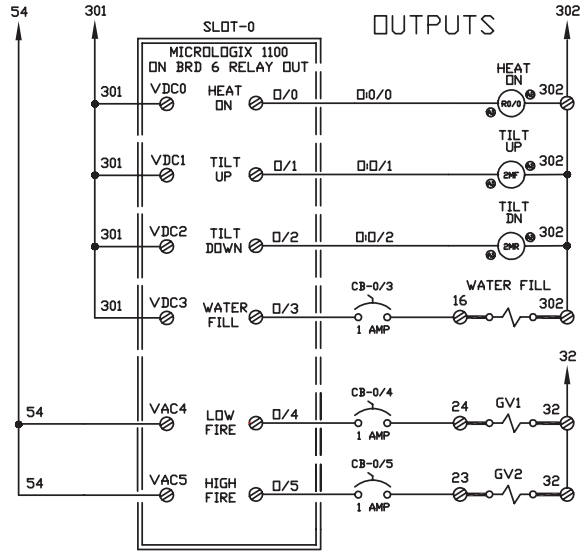
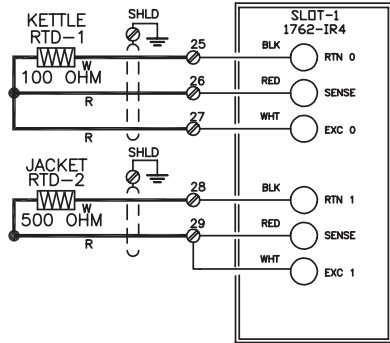
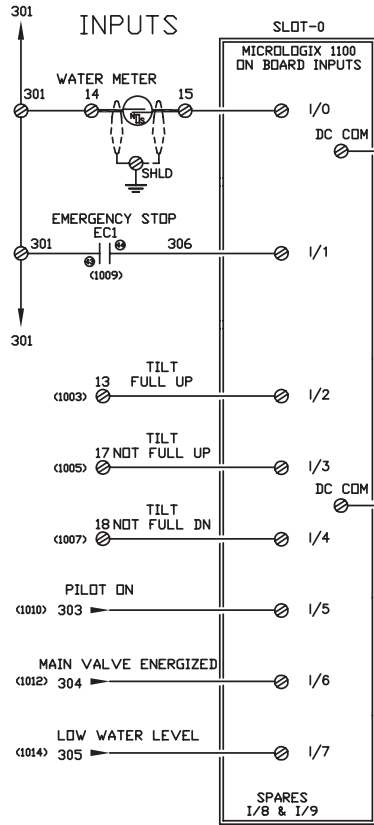
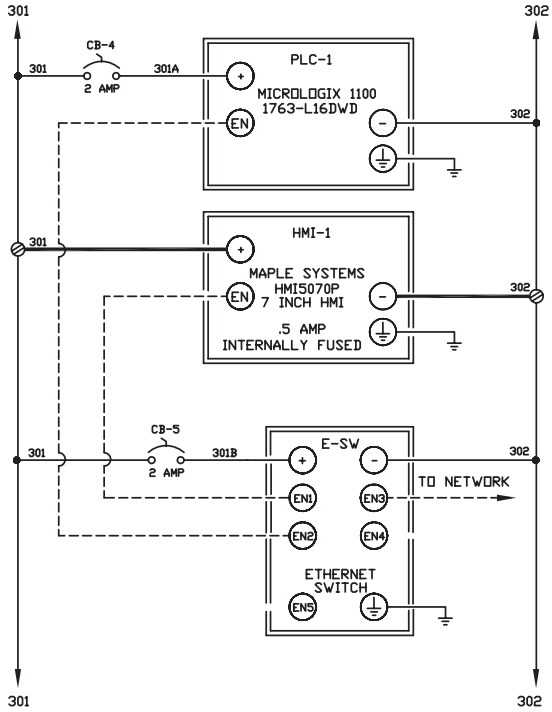

Auxiliary Receptacle

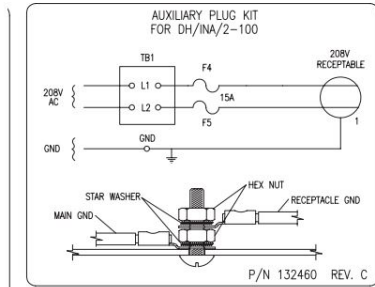

208VAC RECEPTACLE

Receptacle	132456	1
Lift Cover, Weatherproof	132457	1
Terminal Block, 2-Pole	003887	1
Fuse Block, 2-Pole	096809	1
Lug, Ground	119829	1
Fuse, 15A, 600V, Class CC	172042	2

CALL FACTORY FOR REPLACEMENT PARTS:
888-994-7636

Wiring Diagram

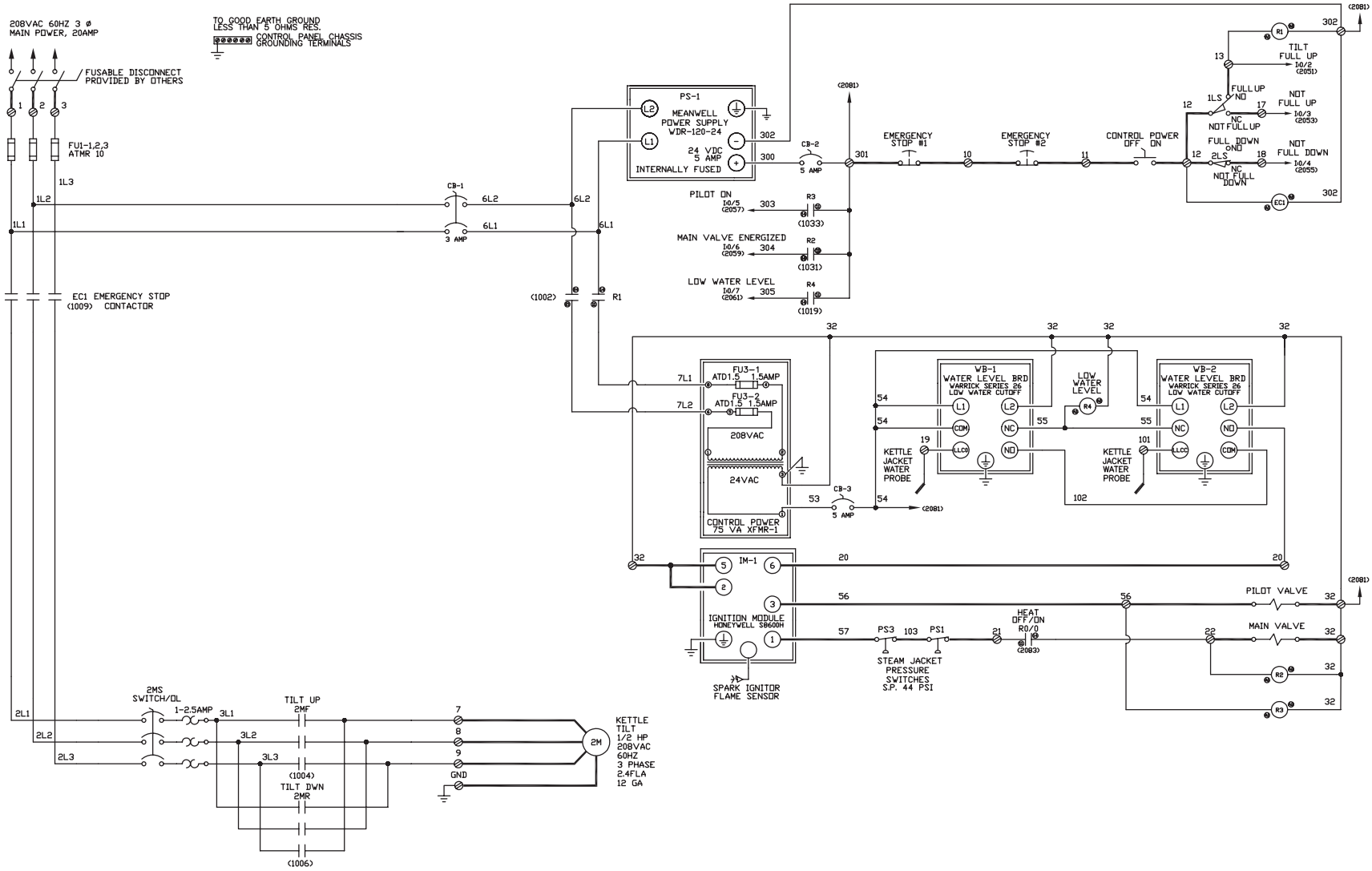

CALL FACTORY FOR REPLACEMENT PARTS:
888-994-7636

Wiring Diagram

