

ITEM NO.	PART NUMBER	DESCRIPTION	QTY.
1	16090-3819	CNH28LP DROP IN HEATER	1
2	16090-3857	REMOVABLE DOOR ASY	1
3	16090-3859	FRONT DUCT ASSEMBLY	1
4	16090-3860	CRUMB DRAWER ASSY CNH28LP	1
5	16090-3873	INNER WRAP ASY 2PC CNH28	1
6	16504-4677	PERFORATED TRAY DIVIDER	2
7	16504-4691	BASE	1
8	16504-4760	ONE PIECE STEP GRATE	1
9	16504-4779	TRAY DIVIDER	1
10	16504-4781	2 PIECE RIGHT OUTER WRAPPER	1
11	16504-4818	2 PIECE LEFT OUTER WRAPPER	1
12	16505-7535	Z BAR	1

REV.	DESCRIPTION	DATE	APPROVED
A	RELEASE TO PRODUCTION	9/11/2015	WM

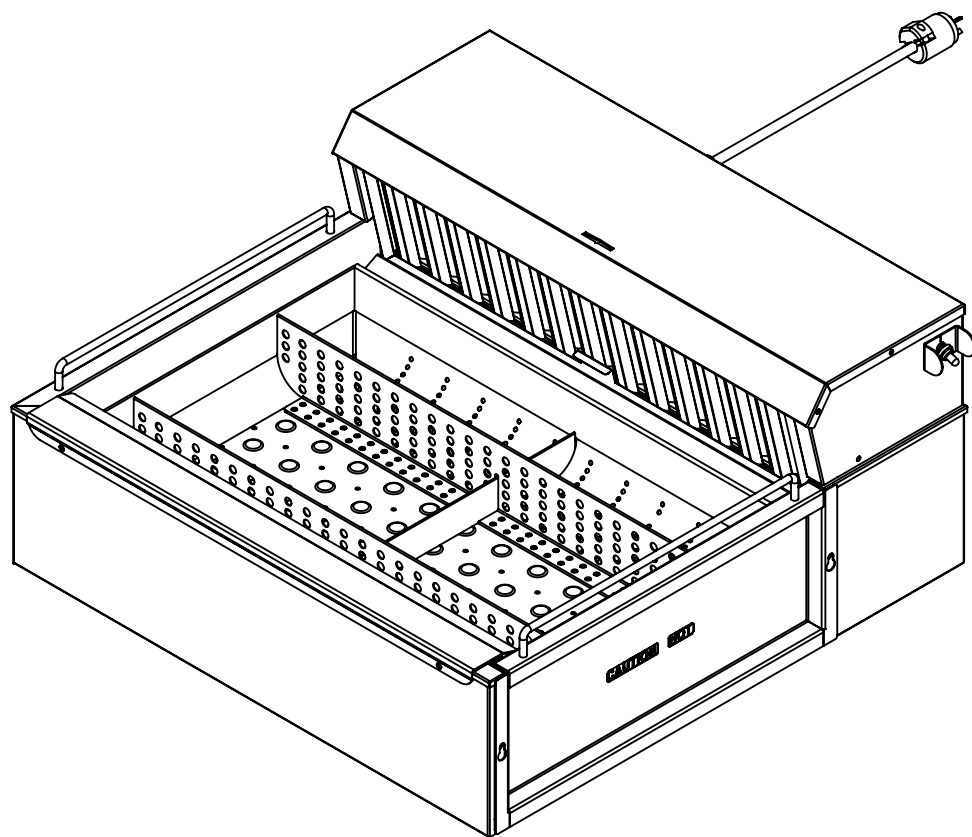
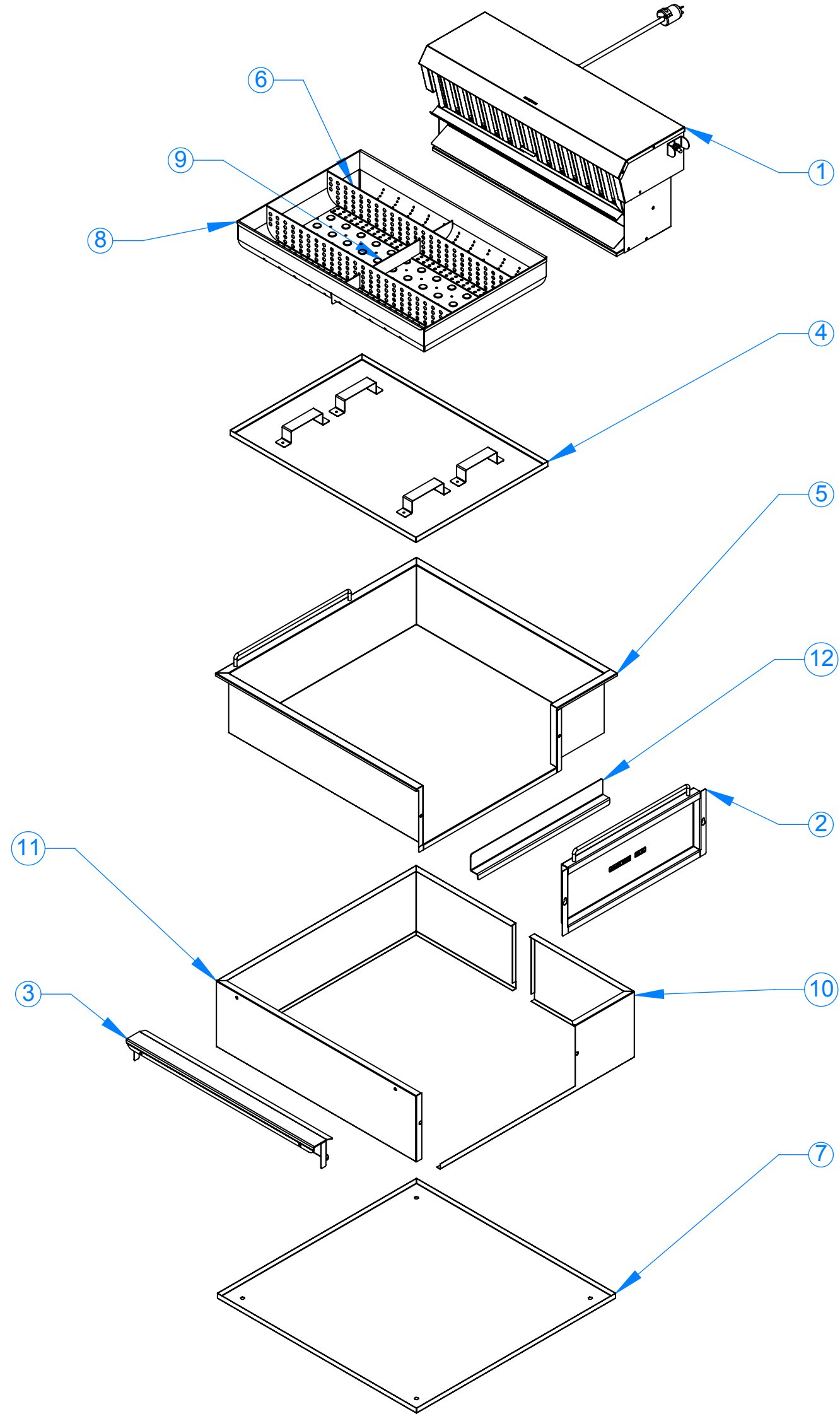

ALL COMPONENTS MUST BE ROHS COMPLIANT

UNLESS OTHERWISE SPECIFIED:
 DIMENSIONS ARE IN INCHES
 FRACTIONAL ± 1/64
 ANGULAR: MACH ± 1 BEND ± .5
 TWO PLACE DECIMAL ± .03
 THREE PLACE DECIMAL ± .031
 ALL INTERNAL REGULAR SHAPES: -.000/+ .003

081313	INIT	DATE
MACHINES		
DRAWN BY		

MATERIAL/FINISH

 WEIGHT:

THE INFORMATION CONTAINED IN THIS DRAWING IS THE SOLE PROPERTY OF CARTER-HOFFMANN LLC. ANY REPRODUCTION IN PART OR AS A WHOLE WITHOUT THE WRITTEN PERMISSION OF CARTER-HOFFMANN LLC IS EXPRESSLY PROHIBITED

Carter-Hoffmann LLC
 1551 McCormick Blvd
 Mundelein, IL 60060
 (800) 323 - 9793

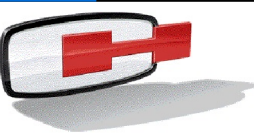

DESC.
CTHM-FRY WARMER, 208V

PROJECT:	
DRAWING NUMBER	REV: A
CNH28LP208	
SCALE = 1:12	SHEET: 1 OF 2

PART REV.:

ITEM NO.	PART NUMBER	DESCRIPTION	QTY.
1	16090-3594	16090-3594	1
2	16504-1988	C-FRAME MOTOR BRACKET	4
3	16504-3222	ELECTRICAL PANEL	1
4	16504-3257	SENSOR BRACKET	1
5	16504-4518	SWITCH GUARD LARGE	1
6	16504-4649	MOTOR & HEATER BRKT	1
7	16504-4655	AIR SECTION TOP COVER	1
8	16504-4656	FILTER BRACKET	1
9	16504-4657	DEFLECTOR	1
10	16504-4658	BOTTOM COVER	1
11	16504-4660	HEAT DUCT	1
12	16504-4661	FILTER BRACKET	1
13	16504-4664	AIR BAFFLE	6
14	16504-4787	TSTAT BRACKET	1
15	16504-4788	AIR SECTION COVER	1
16	18001-0070	3/8-16 18-8 FIN HX FULLNUT	16
17	18001-0210	5/16-18 HEX NUT SS	16
18	18100-0194	5/16-18 x 1 SS Weld Stud	16
19	18120-0091	WASHER, 1"O.D. X .375 I.D. S.S.	32
20	18600-0016	T-STAT G1-2727-000 255F 300F	1
21	18600-0061	HI LIMIT	4
22	18602-0170	30A, switch	1
23	18602-0171	SWITCH BOOT LONGER & M12	1
24	18602-0299	FILTER GREASE 6.38 X 25.720	1
25	18607-0009	TERMINAL BLOCK (6) VDE	1
26	18610-0190	NUT LOCK	1
27	18612-0113	TUBULAR ELEMENT 900W/120V/240V	4
28	18614-0275	FAN GRILL	4
29	18614-0342	HOUSING, SMALL COOLING	4
30	18614-0359	INLET SCREEN	4
31	18614-0363	C-FRAME MOTOR 208V	4
32	18614-0365	BLOWER WHEEL	4
33	18616-9998	CORD GRIP - .375 - .437 SHC1018	1
34	18617-0050	RUBBR PLUG GROMMT 9600K65	16
35	18617-0137	7/8" HOLE PLUG NICKEL PLATED	1
36	18617-0253	GROMMET 1/16" ID .562 GROVE	1

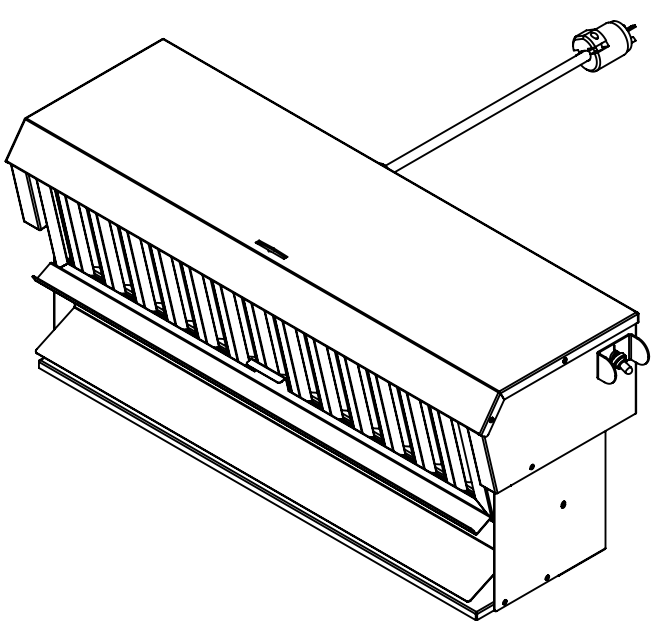
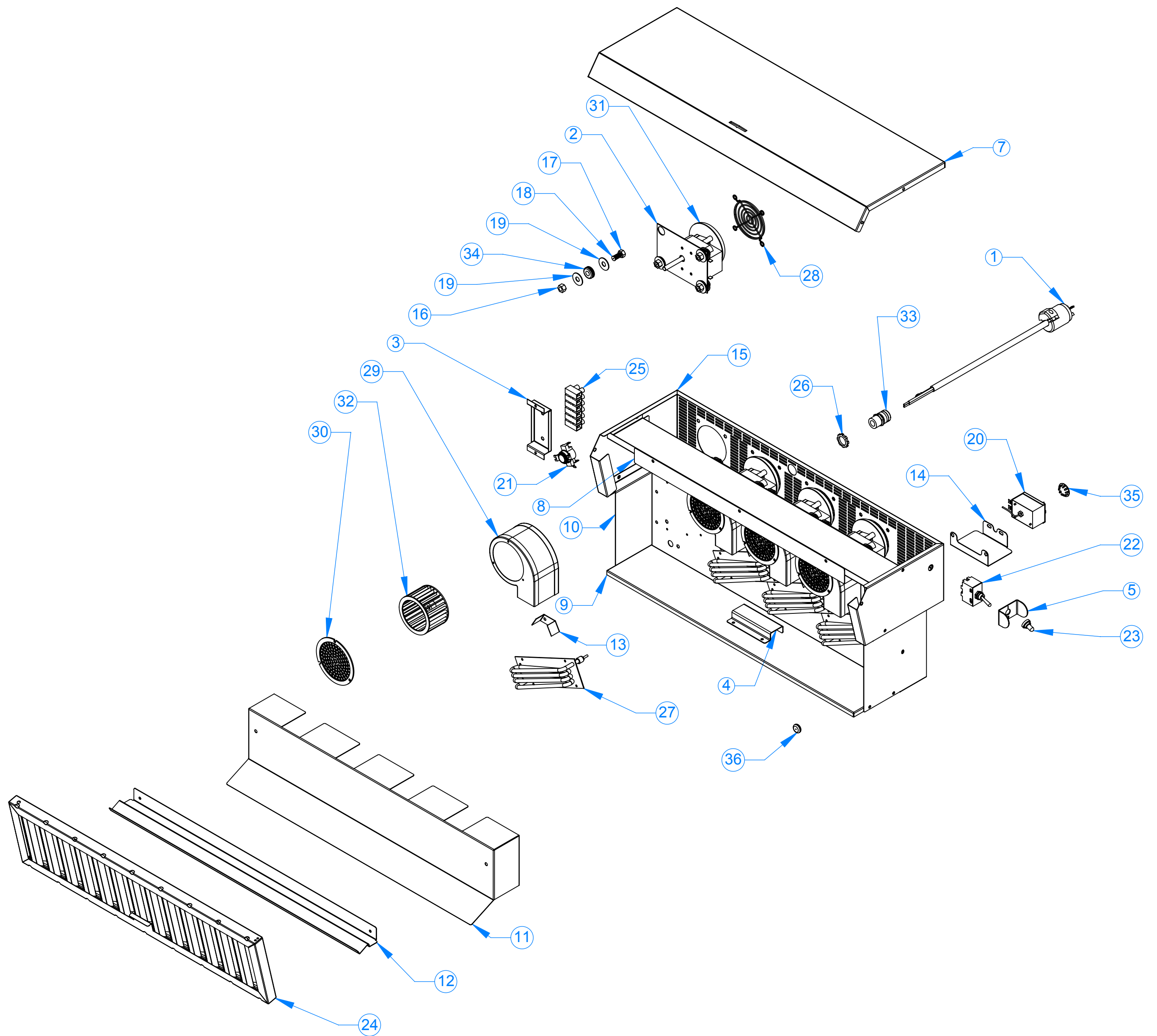

PART REV.: A

ALL COMPONENTS MUST BE ROHS COMPLIANT

UNLESS OTHERWISE SPECIFIED:
DIMENSIONS ARE IN INCHES

FORMED TOLERANCES:
FRACTIONAL ± 1/64
ANGULAR: MACH ± 1 BEND ± 1
TWO PLACE DECIMAL ± .03
THREE PLACE DECIMAL ± .031

ALL INTERNAL REGULAR SHAPES: -.000/+ .003

MATERIAL/FINISH

WEIGHT:
35.1524

081313	INIT	DATE
MACHINES		
DRAWN BY		

THE INFORMATION CONTAINED IN THIS DRAWING IS THE SOLE PROPERTY OF CARTER-HOFFMANN LLC. ANY REPRODUCTION IN PART OR AS A WHOLE WITHOUT THE WRITTEN PERMISSION OF CARTER-HOFFMANN LLC IS EXPRESSLY PROHIBITED

Carter-Hoffmann LLC
1551 McCormick Blvd
Mundelein, IL 60060
(800) 323 - 9793

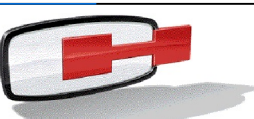

DESC.
CNH28LP DROP IN HEATER

PROJECT: CNH	
DRAWING NUMBER 16090-3819	REV: A
SCALE = 1:24	SHEET: 2 OF 2