

OWNER'S MANUAL

CRISP 'N HOLD FRIED FOOD STATIONS

MODELS: CNH7X17



READ THIS MANUAL
COMPLETELY BEFORE
OPERATING THIS APPLIANCE



CNH7X17



The technical content of this manual, including any wiring diagrams, schematics, parts breakdown illustrations and/or adjustment procedures, is **intended for use by qualified technical personnel** and is subject to change without notice.

This appliance is intended to be used for commercial applications, for example, in kitchens of restaurants, canteens, hospitals and in commercial enterprises such as bakeries, butcheries, etc., but not for continuous mass production of food.

TABLE OF CONTENTS

SAFETY PRECAUTIONS	3
FEATURES & SPECIFICATIONS	4
Dimensions	4
UNPACKING AND INSPECTION	5
FREIGHT DAMAGE CLAIM PROCEDURE	5
INSTALLATION AND STARTUP	6
LOCATION	6
START-UP	7
OPERATING PROCEDURES	8
NORMAL OPERATION	8
CLEANING PROCEDURES	9
WIRING DIAGRAMS	10
TROUBLESHOOTING GUIDE	11
SERVICE EXPECTATIONS	12
Service Philosophy	12
End-User Responsibilities	12
WARRANTY STATEMENT	13
Warranty Service	13
Confidentiality	13
Carter-Hoffmann Warranty:	13
Warranty Exclusions and Limitations:	13

SAFETY PRECAUTIONS



WARNING!

This symbol highlights hazards, which could lead to injury. Please follow the instructions very carefully and proceed with particular attention in these cases



CAUTION!

This symbol highlights instructions, which should be followed to avoid any risk of damage, malfunctioning and/or breakdown



NOTE!

This symbol highlights tips and information, which have to be followed for an efficient and trouble-free operation of the device.



DANGER! Electrical Shock Hazard!

This symbol draws attention to potential electrical hazards (dangerous voltage). If you do not follow the safety instructions, you may risk injury or death.



CAUTION! Hot Surface!

This symbol is a warning that the device surface is hot when in use. Ignoring this warning shall result in burns!



WARNING! Scalding Hazard!

To avoid scalding, do not use loaded containers with liquids or cooking goods which become fluids by heating in higher levels than those which can be easily observed.

This appliance is not intended for use by persons (including children) with reduced physical, sensory or mental capabilities, or lack of experience and knowledge, unless they have been given supervision or instruction concerning use of the appliance by a person responsible for their safety. Children should be supervised to ensure that they do not play with the appliance.

This appliance is not intended to be used by laymen in household and similar applications such as: staff kitchen areas in shops, offices or other working environments; farm houses; hotels, motels, and other residential type environments, bed and breakfast type environments

IMPORTANT SAFETY INSTRUCTIONS



WARNING!

Be familiar with the appliance use, limitations and associated restrictions. Operating instructions must be read and understood by all persons using or installing this appliance.

- This appliance must be grounded. Connect only to properly grounded outlet.
- Use this appliance only for its intended use as described in this manual.
 - a. This equipment is specifically designed to hold pre-cooked food at temperature.
 - b. This equipment is intended for use in commercial establishments only.
 - c. This equipment is not designed for industrial or laboratory use.
 - d. This appliance may be used in an area open to the public.
- Cleanliness of this appliance and accessories is essential to good sanitation.
- ! **DO NOT** submerge this appliance in water. This appliance is not jet stream approved.
- ! **DO NOT** direct water jet or steam jet at this appliance, or at any control panel or wiring.
- ! **DO NOT** splash or pour water on, in or over any controls, control panel or wiring.
- ! **DO NOT** use corrosive chemicals or vapors in this appliance.
- ! **DO NOT** store this appliance outdoors.
- ! **DO NOT** use this product near water – for example, near a kitchen sink, in a wet basement, or near a swimming pool, and the like
- ! **DO NOT** operate this appliance if it has a damaged cord or plug, if it is not working properly, or if it has been damaged or dropped. Do not immerse cord or plug in water, keep cord away from heated surfaces, and do not let cord hang over edge of table or counter.
- ! **DO NOT** cover or block any openings on the appliance.



NOTE!

The technical content of this manual, including any wiring diagrams, schematics, parts breakdown illustrations and/or adjustment procedures, is **intended for use by qualified technical personnel** and is subject to change without notice.

FEATURES & SPECIFICATIONS

Forced Convection Fried Food Holding Station

The Crisp n' Hold maintains fried food temperature and freshness by using a heated stream of air. This air, heated by an electric resistance heater, is ducted to a food grate and discharged through small openings to create a warm air blanket over the food. The grate features small embossments to minimize hot metal contact with the food. It also offers dual-sided access with a removable food grate and crumb pan.

FIG. A CNH7X17



Dimensions

Model Number	Overall Dimensions	
	inches	mm
CNH7X17	17.15"H x 16.75"D x 7.00"W	445 x 425 x 178

Agency Approvals :



Cabinet Material:

300 series stainless steel, 400 series stainless steel, and aluminized steel are used where appropriate for their specific properties and applications.

Controls:

An electrical/mechanical thermostat is mounted inside the electrical cabinet.

Heater System:

An electrical resistance heater is located away from oils and vapors.

Performance:

Temperature range: 85 to 190°F (29 to 88°C). Factory preset to 190°F (88°C). Preheats to 161°F (72°C) in 20 minutes.

Electrical Characteristics

The charts below give electrical specifications for the most popular models, but due to the nature of continuing change to the number of configurations we manufacture, they may not list your model. Refer to the serial tag on your cabinet for actual electrical specifications.

Model Number	Electrical Characteristics					NEMA (6" CORD)
	Watts	Volts	Phase	Hz	Amps	
CNH7X17	700	120	1	60	5.8	5-15P Plug

UNPACKING AND INSPECTION



WARNING!

This appliance should be thoroughly cleaned prior to use. Refer “CLEANING PROCEDURES” on page 9 in this manual.



NOTE!

DO NOT discard the carton or other packing materials until you have inspected the appliance for hidden damage and checked it for proper operation.

Refer to **FREIGHT DAMAGE CLAIM PROCEDURE** on the bottom of this page.

1. Remove the cabinet from shipping carton, ensuring that all packing materials and protective plastic have been removed from the unit.
2. Inspect all components for completeness and condition.
3. If any freight damage is present, a freight claim must be filed immediately with the shipping company.
4. Freight damage is not covered under warranty.

FIG. B EXAMPLE OF SERIAL TAG

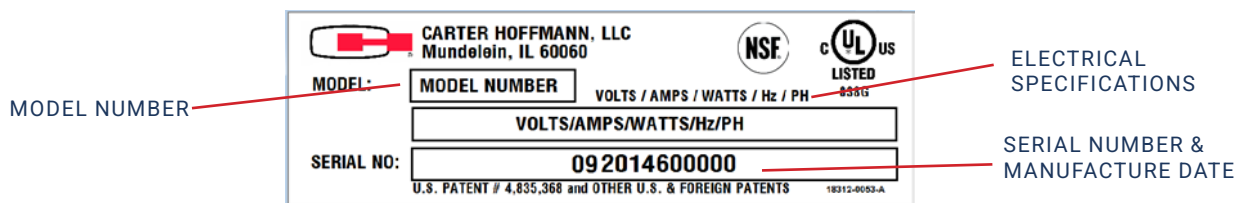

FREIGHT DAMAGE CLAIM PROCEDURE



NOTE!

For your protection, please note that equipment in this shipment was carefully inspected and packaged by skilled personnel before leaving the factory. Upon acceptance of this shipment, the transportation company assumes full responsibility for its safe delivery.

IF SHIPMENT ARRIVES DAMAGED:

1. **VISIBLE LOSS OR DAMAGE:** Be certain that any visible loss or damage is noted on the freight bill or express receipt, and that the note of loss or damage is signed by the delivery person.
2. **FILE CLAIM FOR DAMAGE IMMEDIATELY:** Regardless of the extent of damage. **Contact your dealer immediately.**
3. **CONCEALED DAMAGE:** If damage is unnoticed until the merchandise is unpacked, notify the transportation company or carrier immediately, and then file a “**CONCEALED DAMAGE**” claim with them. This should be done within fifteen (15) days from the date the delivery was made to you. **Be sure to retain the container for inspection.**

Carter-Hoffmann cannot assume liability for damage or loss incurred in transit, **freight damage is not covered under warranty.** We will, however, at your request, supply you with the necessary documents to support your claim.

INSTALLATION AND STARTUP



Risk of Personal Injury

Installation procedures must be performed by a qualified technician with full knowledge of all applicable electrical codes and with proper load-bearing hardware. Failure could result in personal injury and property damage.



Each Power Cord is 6 Feet (183cm) Long

DO NOT use an extension cord. If necessary, contact a licensed electrician to install an appropriate electrical circuit with correct NEMA receptacle for each heater. Reference serial tag on cabinet.



Electrical Shock Hazard

The ground prong of the power cord is part of a system designed to protect you from electric shock in the event of internal damage. **DO NOT** cut off the large round ground prong or twist a blade to fit an existing receptacle.



Risk of Personal Injury

Unit is not waterproof. To avoid electrical shock, keep unit and counter from being submerged in water. Do not operate if the unit has been in contact with water.



Counter Top Location Only

This cabinet is not intended to be dropped into an enclosed compartment. It must be placed on a counter. The counter must be made of a non-combustible material, located away and shielded from combustible materials, clean and free of debris.



Not Under Warranty

Damage to unit due to being connected to the wrong voltage or phase is **NOT** covered by warranty. Damage caused by leaks due to improper installation is not covered by warranty.

LOCATION

Read this manual completely before installing equipment.

For proper operation and maximum performance, locate the Crisp n' Hold in an ambient air temperature of 70° F (21°C).

Avoid areas near exhaust fans where there is active air movement. For safe operation, locate the unit a reasonable distance from combustible walls and materials.

To prevent injury and damage, locate the unit at a proper and safe working height. The location should be level, clean of debris, and strong enough to support the weight of a fully loaded unit.

To prevent electrical shock during installation, make sure unit is not plugged into an electrical outlet. If unit has been operated, allow to cool before installing.



COUNTERTOP LOCATION

This cabinet is not intended to be dropped into an enclosed compartment. It must be placed on a counter. The counter must be made of a non-combustible material, located away and shielded from combustible materials, clean and free of debris.

INSTALLATION AND STARTUP



CAUTION!

Front and back of cabinet must remain clear for access. Maintain 2" of clearance on each side of cabinet to allow for adequate cooling.

The power connection for each heater is a grounded plug. Electrical information for each heater is provided on the serial tag on the side of the cabinet.

Verify that the proper electrical service required for this cabinet is available prior to installation. Plug the power cord into grounded outlet with electrical service according to the "Electrical Characteristics" on page 4 or the serial tag.

FIG. C EXAMPLE OF SERIAL TAG

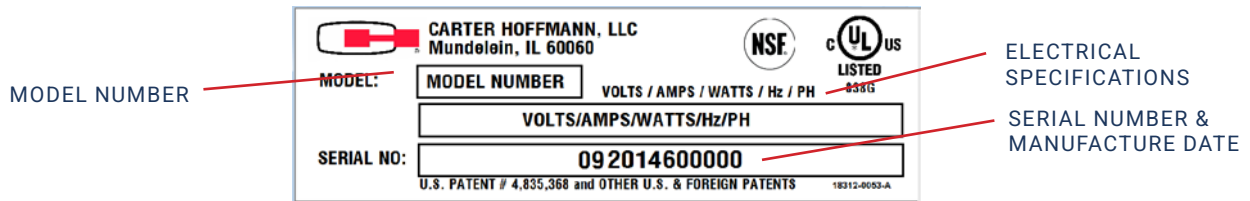

GROUNDING INSTRUCTIONS

To prevent an electrical shock hazard between the appliance and other appliances or metal parts in close vicinity, an equalization-bonding stud is provided. An equalization bonding lead must be connected to this stud and the other appliances/metal parts to provide sufficient protection against potential difference.

This appliance is equipped with a cord having a grounding wire with a grounding plug which must be plugged into an outlet that is properly installed and grounded. In the event of an electrical short circuit, grounding reduces the risk of electric shock by providing an escape wire for the electric current.

The terminal is marked with the following symbol:



WARNING!

Improper use of the grounding can result in a risk of electric shock. Consult a qualified electrician or serviceman if the grounding instructions are not completely understood, or if doubt exists as to whether the appliance is properly grounded. The ground lug of this appliance must be connected to a suitable building ground.

START-UP

1. Plug the Crisp n' Hold into a properly grounded electrical receptacle. See serial tag on the side of the unit to verify the proper electrical requirements.
2. Ensure all plastic and packaging materials have been removed.
3. Set POWER switch to "ON" position.
4. Do not load product into the cabinet. Allow the heat to remove any residual oils which may adhere to inside metal surfaces. A slight emission of smoke is normal for the first few hours of operation.
5. Cabinet is preset at the factory, no temperature adjustment is necessary.

OPERATING PROCEDURES



CAUTION! Hot Surface!

Inner surfaces of the unit will be very hot during and after operation. Avoid touching the cabinet when loading or removing product.

NORMAL OPERATION

1. Prior to use, unit must have been installed properly and tested by a trained installation or service professional.
2. Unit must be clean and grease free prior to use.
3. Verify that the crumb pan and food grate are installed properly.



Note !

The crumb tray will fit in one direction but not the other. If it does not fit properly, turn it around.

4. Turn power on by flipping the toggle switch upwards. The motors should begin to turn and create airflow.
5. Unit will automatically begin to preheat, allow 30 minutes for unit to climb to operating temperature of 190°F (88°C).

6. Load product into Crisp n' Hold.
7. The cabinet must be cleaned daily. Perform cleaning at the end of each day. It is important to follow the cleaning procedures to keep grease and debris from building up. Failure to perform daily cleaning will clog the filters and damage the electrical components. Refer "CLEANING PROCEDURES" on page 9 or cleaning instructions..

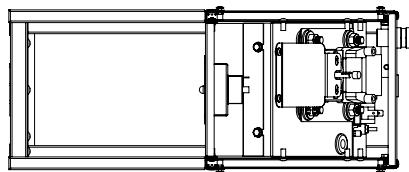
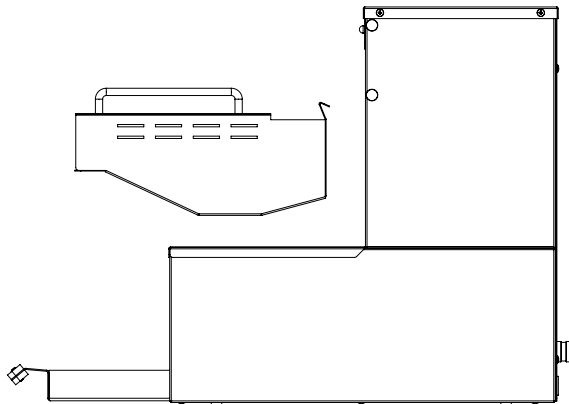

TOP VIEW
MACHINE SHOWN WITH
NO FOOD GRATE
AND NO CRUMB TRAY

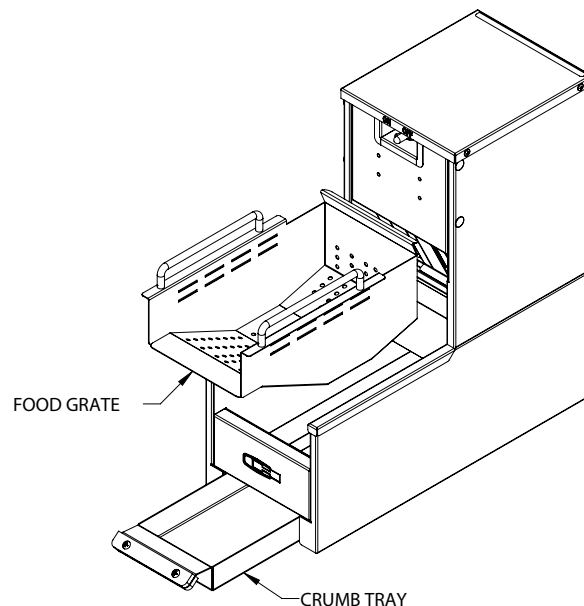

NOTE!

The technical content of this manual, including any wiring diagrams, schematics, parts breakdown illustrations and/or adjustment procedures, is intended for use by qualified technical personnel and is subject to change without notice.

CLEANING PROCEDURES



DANGER! Electrical Shock Hazard!
Disconnect appliance from electric power before cleaning.



WARNING!
In order to achieve all pole disconnect, unplug power cord from receptacle/power source.



WARNING!
Beware of sharp edges with sheet metal during cleaning process



CAUTION! Hot Surface!
Exposed surfaces can be hot to the touch and may cause burns. Allow appliance to cool before cleaning.



CAUTION!
DO NOT spill or pour water into controls, control panel or wiring. Water damage is not covered by the warranty. DO NOT use steel wool pads to clean the cabinet. Ferrous deposits will cause rusting.

FIG. D CNH7X17

Daily Cleaning

1. After all food products have been removed from the cabinet, turn the power switch to "OFF" and allow the cabinet to cool for 30 minutes.
2. Unplug the unit prior to any cleaning.
3. The unit consists of three assemblies: base (housing all electrical components), crumb pan and food grate.
4. Lift out the food grate and crumb pan. Clean them by hand washing with soap and water and rinsing thoroughly with clean water. They may also be run through an automatic dish washer.
5. Reinstall when all parts are dry and clean.
6. Inspect and clean the areas where there are vents, making sure no water gets into the internal controls or electrical areas of the cabinet.

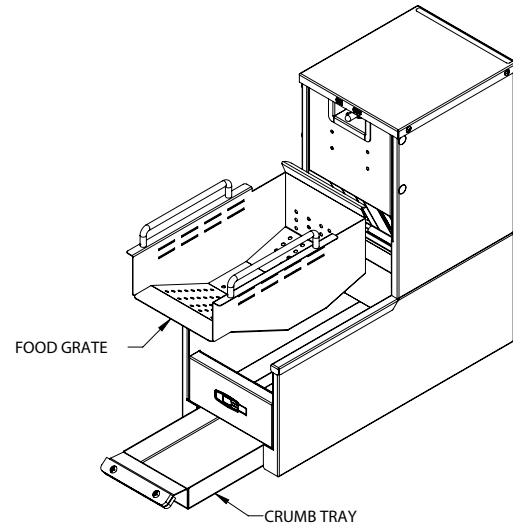

Weekly Cleaning

- Remove the grease filter and clean it weekly.



CAUTION! POTENTIAL DAMAGE TO STAINLESS STEEL
Cleansers, detergents, degreasers, sanitizers, or bleaching agents that contain chlorides or phosphates will cause permanent damage to stainless steel products. The damage appears as pits, eruptions, voids, small holes, severe discoloration or dulling of the metal finish. Water with high chloride content can also damage stainless steel. If unsure of your water quality, we recommend you have it tested.

THIS DAMAGE IS PERMANENT, COSTLY TO REPAIR, AND IS NOT COVERED BY THE WARRANTY.

RECOMMENDED TIPS FOR CLEANING STAINLESS STEEL			
PURPOSE	FREQUENCY	CLEANING AGENT	METHOD OF APPLICATION
Routine Cleaning	Daily	Soap, ammonia, cleaning detergent and water	Sponge with cloth, rinse with clear water
Smears and fingerprints	As needed	Stainless steel cleaner or similar product	Rub with soft cloth as directed by the manufacturer. Rub in the direction of the grain of stainless steel. Do not use on vinyl trim
Stubborn spots and stains	Daily, as needed	Any chloride-free or phosphate-free cleaner	Apply with damp sponge. Rub in the direction of the grain of stainless steel. Rinse thoroughly, especially if cleaner contains chlorine bleach. Do not use on vinyl trim.
Hard water spots	Daily, as needed	Vinegar	Swab with cloth. Rinse with water and wipe dry.

WIRING DIAGRAMS

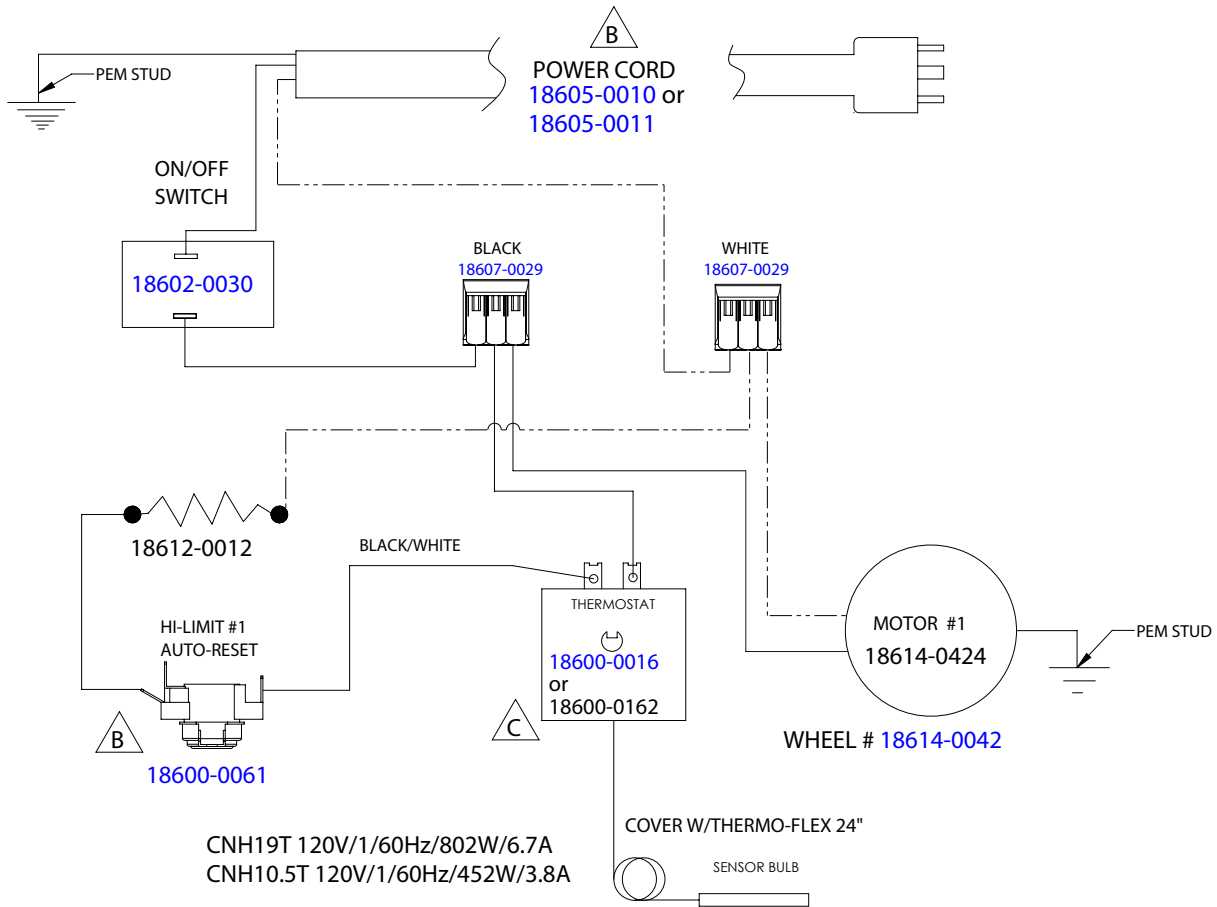

Model Number	Electrical Characteristics				
	Watts	Volts	Phase	Hz	Amps
CNH7X17	700	120	1	60	5.8

Replacement Parts List

PART NUMBER	DESCRIPTION
18600-0030	ON/OFF SWITCH
18600-0061	HI-LIMIT (AUTO-RESET)
18612-0012	HEATER ELEMENT
18614-0424	MOTOR #1
18614-0042	WHEEL
18605-0010 or 18605-0011	POWER CORD 16/3 SJO CORD W/ 5-15 PLUG
18607-0029	CONNECTOR
18600-0016 or 18600 0162	THERMOSTAT

ILLUSTRATED PARTS LIST

For Qualified Service Personnel Only

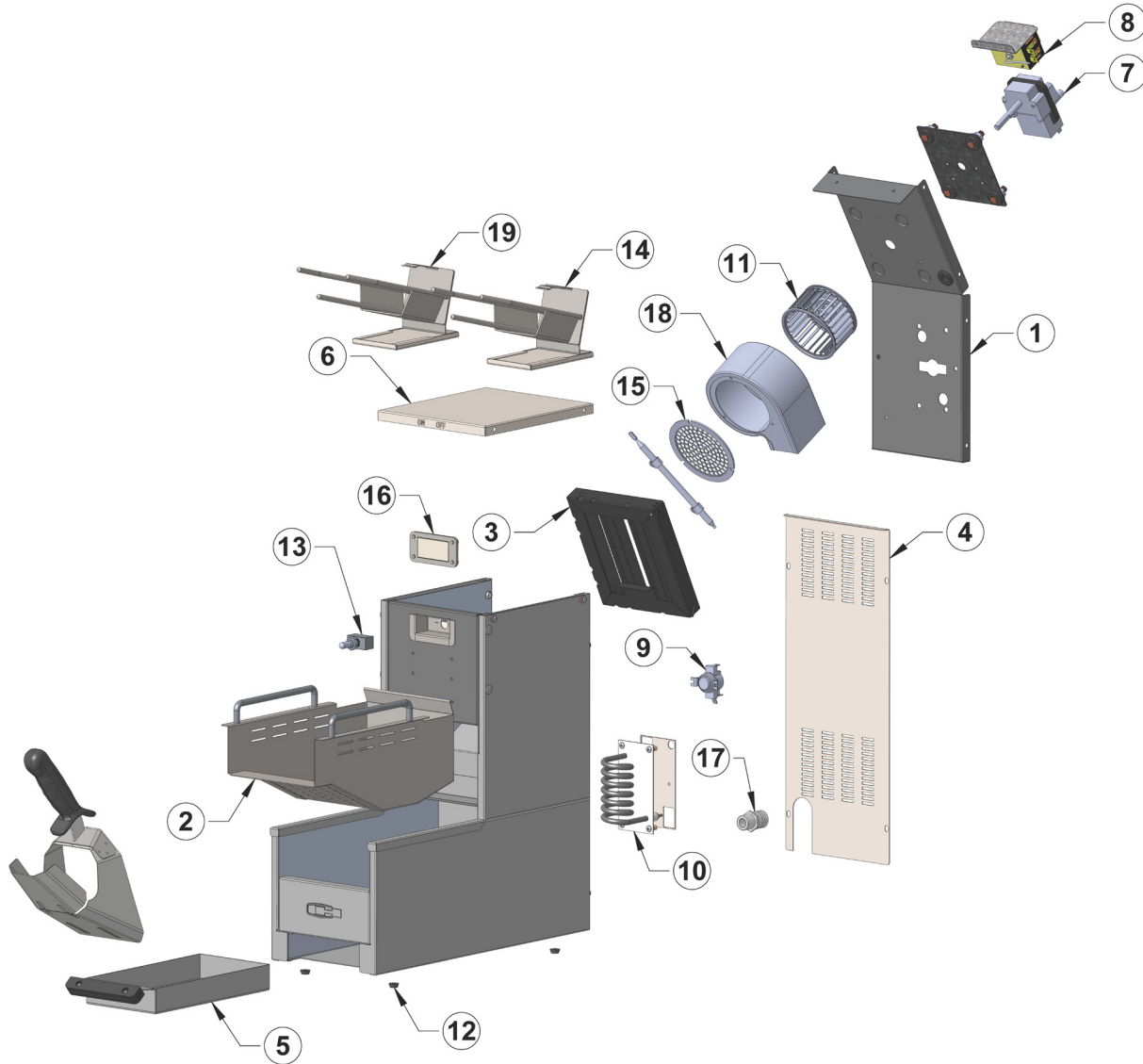

Replacement Parts List

ITEM NO.	PART NUMBER	DESCRIPTION
1	16504-9228	MOTOR & HEATER BRKT
2	16095-4329	FOOD GRATE ASY
3	GREASE FILTER	FILTER GREASE
4	16504-9229	REAR PANEL
5	16504-9232	CRUMB TRAY
6	16504-9230	OUTER TOP, NO MAGNETS
7	18614-0424	CW MOTOR C-FRAME 120V
8	18600-0016 OR 18600-0162	T-STAT G1-2727-000 255F 300F THERMOSTAT 85-255 °F
9	18600-0061	SNAP DISK 3/4" 350F AUTO RESET
10	18612-0012	ELEMENT, 230V, 675W BOX
11	18614-0042	3.187 BLOWER WHEEL
12	18305-0076	RECESS BUMPER #9540K42

ITEM NO.	PART NUMBER	DESCRIPTION
13	18602-0030	SWITCH, 240V, 20A DPST TOGGLE
14	16090-4449	SMALL FRIES BOX HOLDER SINGLE
15	18614-0359	INLET SCREEN
16	16095-4340	MAGNET ASSY FOR FRY SCOOP
17	18617-0002	CORD GRIP
18	18614-0413	FAN HOUSING
19	16090-4460	LARGE FRIES BOX HOLDER SINGLE

TROUBLESHOOTING GUIDE

SYMPTOM	POSSIBLE CAUSE	SUGGESTED REMEDY
No power to unit	Not plugged in or circuit breaker tripped	Check or reset circuit breaker Connect to proper receptacle
	Power cord damaged	Call service technician
	Power switch damaged or defective	Call service technician
Food dries out too quickly	Thermostat incorrectly set or defective	Call service technician
	Lid not installed/not installed properly	Install lid/check for gaps and adjust
Unit is on, but no heat	Internal wiring error	Call service technician
	Element hi-limit trip /defective	Call service technician
Takes too long to get to temperature	Improper voltage	Call service technician
	Bad element	
	Fan motor not working	
<p><i>NOTE: For warranty service, call Carter-Hoffmann direct at 800-323-9793 or email technicalservice@carter-hoffmann.com for authorization, we will dispatch the nearest authorized service agency.</i></p>		



NOTE!

Replacement parts may be ordered from Parts Town: www.partstown.com



NOTE!

For warranty service, call Carter-Hoffmann direct at 800-323-9793 or email technicalservice@carter-hoffmann.com for authorization, we will dispatch the nearest authorized service agency.



NOTE!

The technical content of this manual, including any wiring diagrams, schematics, parts breakdown illustrations and / or adjustment procedures, is **intended for use ONLY by qualified technical personnel.**

SERVICE EXPECTATIONS

Service Philosophy

For over sixty years, Carter-Hoffmann has earned a reputation for manufacturing rugged and dependable foodservice equipment that permits foodservice professionals serve better food products to more people, and thus, grow their business.

Our goal is not only to provide the best food service equipment for the price, but also to back it up with after-sale service that is responsive, fast, efficient and professional. Carter-Hoffmann products are innovative and efficient. They are easy to use, easy to clean and easy to maintain.

Although the products are quite reliable, they are also designed to be easy to repair when necessary.

We believe that a malfunction to a Carter-Hoffmann product should cause as little inconvenience to the customer as possible. Our goal is to provide the same day service or within 24 hours and strive to fix it the first time. We are dedicated to making every aspect of our customer service the standard by which others are judged.

End-User Responsibilities

While we all strive to serve our mutual customers as well as possible, we remind the end-user (and their employees) that they also have some responsibilities.

1. All shipping damage must be noted on the freight bill when the shipment is received. Any freight damages must be collected from the Freight Company, NOT Carter-Hoffmann.
2. The end-user should be advised beforehand to carefully unpack and inspect all products when they are received BEFORE SIGNING THE SHIPPER'S RECEIPT OF DELIVERY.
3. The end-user must provide a safe, dry, level surface for the equipment to be placed upon.
4. The end-user must provide the proper electrical supply. All in-wall electrical modifications are to be completed by a licensed electrician. All building modifications are the responsibility of the end-user. Specification literature changes frequently, please verify proper installation is possible.
5. The end-user must operate, clean and maintain the equipment in accordance with the procedures described in this Operation Manual.
6. Carter-Hoffmann is NOT responsible for any loss of the customer's income, loss of food product, extra labor charges, or any other incidental or consequential costs as a result of the malfunction of our product.
7. The end-user shall allow for on-premises repair of the equipment to be completed at a mutually convenient place and time.



NOTE!

The technical content of this manual, including any wiring diagrams, schematics, parts breakdown illustrations and/or adjustment procedures, is intended for use **ONLY by qualified technical personnel** and is subject to change WITHOUT notice.

WARRANTY STATEMENT

Warranty Service

1. Warranty service is to be **initiated** by authorized Carter-Hoffmann personnel only, please call Carter-Hoffmann directly and we will take care of everything.
2. The service provider is **NOT** authorized to change or extend any of the terms or conditions of our warranty.
3. Initial freight damage is **NOT** covered by the product warranty.

Confidentiality

The end user and all his employees and sub-agents shall protect and keep confidential Carter-Hoffmann's proprietary designs, information, and knowledge. All literature and informational materials provided by Carter-Hoffmann are to be considered confidential; they remain Carter-Hoffmann's property; and are not to be reproduced without our prior approval

For technical service:
contact : 1.847.362.5500
or
email : technicalservice@carter-hoffmann.com.

Carter-Hoffmann Warranty:

Carter-Hoffmann ("CARTER-HOFFMANN") warrants to the initial purchaser of its standard Carter Line Products that CARTER-HOFFMANN will, at its option, repair or replace, during the warranty period set forth below, any part of such products made necessary due to a defect in material or workmanship which is present when the product leaves its factory and which manifests itself during the warranty period under normal use and service.

This warranty applies only to original equipment owned and possessed by the initial purchaser and the warranty period begins on the date of original shipment from the CARTER-HOFFMANN factory and extends as follows: **to component parts and labor for 12 months (36 months on hot LOGIX holding cabinets, levels 3 through 10, and cook & hold cabinets); to refrigeration compressor unit for one year (limited to replacement only - not to include labor for removal, repair or replacement).**

Repair or replacements under this warranty will be performed, unless otherwise authorized in writing by CARTER-HOFFMANN, at its factory. All parts or components to be repaired or replaced under this warranty are to be shipped prepaid to CARTER-HOFFMANN, with reimbursement credit for such part or component to be given if found by CARTER-HOFFMANN to be defective. CARTER-HOFFMANN neither makes nor assumes and does not authorize any other person to make or assume any obligation or liability in connection with its products other than that covered in this warranty. This warranty applies only within the continental United States and Canada. In Alaska and Hawaii, this warranty applies only to and is limited to the supply of replacement parts.

Warranty Exclusions and Limitations:

Any implied warranty of merchantability or fitness for a particular purpose is hereby specifically disclaimed by CARTER-HOFFMANN. There are no warranties, expressed or implied, which extend beyond the description on the face hereof. This warranty does not cover and CARTER-HOFFMANN shall not under any circumstances be liable for any incidental, consequential or other damages (such as injury to persons or property, loss of time, inconvenience, loss of business or profits, or other matters not specifically covered) arising in connection with the use of, inability to use, or failure of these products.

Specifications subject to change through product improvement and innovation.

PROUD MEMBER OF



GET IN TOUCH.

PLEASE CALL

1-847.362.5500

800.323.9793 (Toll Free: USA & Canada)

OR

FAX

1-847.367.8981

OR

EMAIL

technicalservice@carter-hoffmann.com

CARTER-HOFFMANN

1551 McCormick Avenue
Mundelein, IL 60060 U.S.A.

www.carter-hoffmann.com