

# KFCEVOBH BUN HOLDING CABINETS For KFC **OWNERS / OPERATORS MANUAL**



MANUFACTURED BY:

**CARTER-HOFFMANN**  
1551 McCormick Avenue  
Mundelein, IL 60060 U.S.A.

Phone: 847-362-5500

Fax: 847-367-8981

Toll Free: 800-421-3744

Email: [TechnicalService@Carter-Hoffmann.com](mailto:TechnicalService@Carter-Hoffmann.com)



KFCEVOBH & KFCEVOBH240

## TABLE OF CONTENTS

	<b>PAGE</b>
SAFETY PRECAUTIONS	2
FEATURES & SPECIFICATIONS	3
UNPACKING, INSPECTION & FREIGHT DAMAGE	4
INSTALLATION & STARTUP	5
CONTROL PANEL LAYOUT	6
OPERATION	6
CONTROLLER PROGRAMMING INSTRUCTIONS	7
DAILY CLEANING PROCEDURES	8
TIPS FOR CLEANING STAINLESS STEEL	9
WIRING DIAGRAM & REPLACEMENT PARTS LIST	10
TROUBLESHOOTING GUIDE	11-12
WARRANTY STATEMENT	13

## SAFETY PRECAUTIONS



### WARNING: ELECTRIC SHOCK HAZARD

All service requiring access to non-insulated components must be performed by qualified service personnel. Failure to heed this warning may result in severe electric shock.



### CAUTION: ELECTRIC SHOCK HAZARD

Disconnect this appliance from electrical power before performing any maintenance or service.



### CAUTION: BURN HAZARD

Exposed metal surfaces can be hot to the touch and may cause burns.

## IMPORTANT SAFETY INSTRUCTIONS

When using electrical appliances basic safety precautions should be adhered to, including the following:

- 1) Be familiar with the appliance use, limitations and associated restrictions. Operating instructions must be read and understood by all persons using or installing this appliance.
- 2) This appliance must be grounded. Connect only to properly grounded outlet.
- 3) Use this appliance only for its intended purpose as described in the manual.
  - a. This equipment is specifically designed to hold pre-cooked food at temperature.
  - b. This equipment is intended for use in commercial establishments only.
  - c. This equipment is not designed for industrial or laboratory use.
- 4) Cleanliness of this appliance and its accessories is essential to good sanitation.
- 5) DO NOT submerge this appliance in water. This appliance is not jet stream approved. DO NOT direct water jet or steam jet at this appliance, or at any control panel or wiring. DO NOT splash or pour water on, in or over any controls, control panel or wiring. DO NOT use corrosive chemicals or vapors in this appliance.
- 6) DO NOT store this appliance outdoors. DO NOT use this product near water – for example, near a kitchen sink, in a wet basement, or near a swimming pool, and the like.
- 7) DO NOT operate this appliance if it has a damaged cord or plug, if it is not working properly, or if it has been damaged or dropped. Do not immerse cord or plug in water, keep cord away from heated surfaces, and do not let cord hang over edge of table or counter.
- 8) DO NOT cover or block any openings on the appliance.
- 9) **Only qualified service personnel should service this appliance.**

**NOTE:** The technical content of this manual, including any wiring diagrams, schematics, parts breakdown illustrations and/or adjustment procedures, is **intended for use by qualified technical personnel** and is subject to change without notice.

## FEATURES & SPECIFICATIONS



KFCEVOBH  
&  
KFCEVOBH240

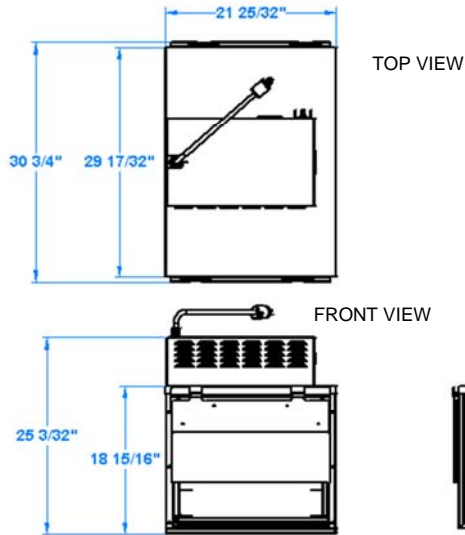

Model	Overall Dimensions *	Electrical Information (each heater)	Description	Shipping Weight
KFCEVOBH	25.09"H x 30.75"D x 21.78"W	208V, 2400W, 12A, 50/60Hz, 1Ph	Bun holding; 208 volt version	123 lbs
KFCEVOBH240	25.09"H x 30.75"D x 21.78"W	240V, 2400W, 10.5A, 50/60Hz, 1Ph	Bun holding; 240 volt version	123 lbs

### Features & Benefits

- All stainless steel construction with polycarbonate flip up doors and pass-through access.
- Precision-engineered heat ducts with blower fan for even heat distribution throughout cabinet.
- Removable heating units. Digitally controlled and monitored temperature, with digital temperature read-out; pre-set factory temperatures of 140°F. On/Off toggle switch.
- Designed for over-counter holding and warming of sandwich buns.
- Polycarbonate shields over top of opening with flip up feature enhance heating operation.
- Supplied with 14/3 HSJO power cord and NEMA L6-15 plug.

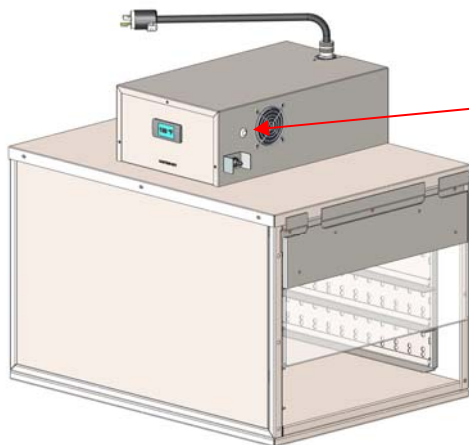

The KFCEVOBH is equipped with a temperature activated heat limit switch that will interrupt the power to the heater tubes if the temperature inside the control box exceeds 160°F (71°C). The HIGH LIMIT/RESET can be manually reset by pushing the button located on the side of the control box as shown.



**Intertek**

3194974  
Conforms with  
UL STD 197



**Intertek**

3194974  
Conforms with  
NSF/ANSI  
STD 4

## UNPACKING AND INSPECTION



This appliance should be thoroughly cleaned prior to use.

See the **CLEANING INSTRUCTIONS** in this manual.

---

**NOTE: DO NOT** discard the carton or other packing materials until you have inspected the appliance for hidden damage and checked it for proper operation.

Refer to **FREIGHT DAMAGE CLAIM PROCEDURE** on bottom of this page.

1. Remove the cabinet from shipping carton, ensuring that all packing materials and protective plastic has been removed from the unit.
2. Inspect all components for completeness and condition.
3. If any freight damage is present, a freight claim must be filed immediately with the shipping company.
4. **Freight damage is not covered under warranty.**
5. Check to insure all components are included: cabinet, instruction packet, mounting brackets and additional accessories, where applicable.
6. Read operation instructions completely.
7. Appliance should be thoroughly cleaned before use. See **CLEANING INSTRUCTIONS** in this manual (page 8).

### FREIGHT DAMAGE CLAIM PROCEDURE

**NOTE:** For your protection, please note that equipment in this shipment was carefully inspected and packaged by skilled personnel before leaving the factory. Upon acceptance of this shipment, the transportation company assumes full responsibility for its safe delivery.

#### IF SHIPMENT ARRIVES DAMAGED:

1. **VISIBLE LOSS OR DAMAGE:** Be certain that any visible loss or damage is noted on the freight bill or express receipt, and that the note of loss or damage is signed by the delivery person.
2. **FILE CLAIM FOR DAMAGE IMMEDIATELY:** Regardless of the extent of damage. **Contact your dealer immediately.**
3. **CONCEALED DAMAGE:** If damage is unnoticed until the merchandise is unpacked, notify the transportation company or carrier immediately, and then file a "CONCEALED DAMAGE" claim with them. This should be done within fifteen (15) days from the date the delivery was made to you. **Be sure to retain the container for inspection.**

Carter-Hoffmann cannot assume liability for damage or loss incurred in transit, **freight damage is not covered under warranty.** We will, however, at your request, supply you with the necessary documents to support your claim.

## INSTALLATION and START-UP



### **WARNING:** Risk of personal injury

Installation procedures must be performed by a qualified technician with full knowledge of all applicable electrical codes and with proper load-bearing hardware. Failure could result in personal injury and property damage.



### **IMPORTANT:** Power cord is 6' long

If necessary, contact a licensed electrician to install an appropriate 15 amp electrical circuit with correct NEMA receptacle for the heater.

**DO NOT use an extension cord.**



### **CAUTION:** Electrical Shock Hazard

The ground prong of the power cord is part of a system designed to protect you from electric shock in the event of internal damage.

DO NOT cut off the large round ground prong or twist a blade to fit an existing receptacle.



### **IMPORTANT:** Not under warranty

Damage to unit due to being connected to the wrong voltage or phase is **NOT** covered by warranty.



### **WARNING:** Risk of personal injury

Unit is not waterproof, to avoid electrical shock, keep unit and counter from being submerged in water. Do not operate if unit has been in contact with water.

### LOCATION

Read equipment manual completely before installing and operating the cabinet.

**Unit must be installed by qualified service personnel only.** Unit must be installed in such a fashion to bear the weight of the cabinet when fully loaded; minimum 350 pounds.

The power connection for each heater is a grounded plug. Electrical information for the heater is provided on the **heater** serial tag on the front of the heater. Verify that the proper electrical service required for this cabinet is available prior to installation. Plug the power cords into grounded outlets with an electrical service according to the electrical information provided on page 3.

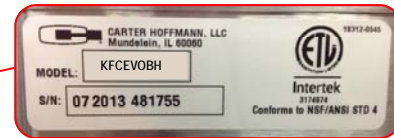

Cabinet serial tag (Note serial number if calling for service)

### **GROUNDING INSTRUCTIONS**

This appliance is equipped with a cord having a grounding wire with a grounding plug which must be plugged into an outlet that is properly installed and grounded. In the event of an electrical short circuit, grounding reduces the risk of electric shock by providing an escape wire for the electric current.

**WARNING—Improper use of the grounding can result in a risk of electric shock.** Consult a qualified electrician or service agent if the grounding instructions are not completely understood, or if doubt exists as to whether the appliance is properly grounded.

### START-UP

1. Prior to use, thoroughly clean the interior of the unit, according to the instructions in this manual (see page 8).
2. Plug the power cord of the cabinet into grounded outlet with an electrical service according to the electrical information provided on page 3. Set POWER switch to the "ON" position.
3. Do not load product into the cabinet. Allow the heat to remove any residual oils which may adhere to inside metal surfaces. A slight emission of vapor is common during the first few hours of operation.

## CONTROL PANEL LAYOUT

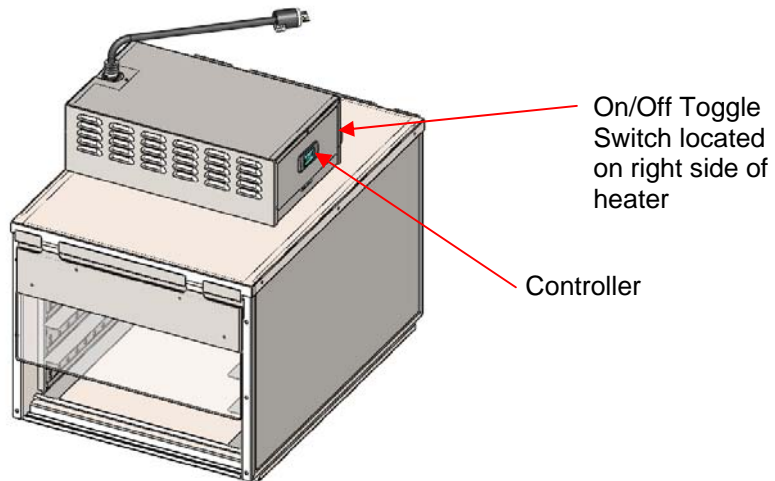

## OPERATION

AUX Key  
(inoperable)

Set Key  
Press and release  
to display temper-  
ature set point



Up Arrow Key  
Press to increase temperature set point  
(1° increments)

Down Arrow Key  
Press to decrease temperature set point  
(1° increments)



### CAUTION: HOT SURFACE

Inner surfaces of the unit will be very hot during and after operation. Avoid touching the cabinet when loading or removing product.

1. Turn the power switch ON and let cabinet preheat for 30 minutes. When the cabinet is turned on, the air heater will operate until the cabinet reaches the air temperature setpoint. Display will read the actual temperature.

 The temp icon will be illuminated when the cabinet temperature is below the air temperature setpoint.

2. To view the temperature setpoint, press and release the SET key.
3. After preheat, load cabinet with food product. Food is held in various pan sizes as indicated by the spacing of the wire racks inside the cabinet.
4. When cabinet is not in use, turn power off.
5. Cabinet must be cleaned daily. See cleaning instructions on page 8.

## CONTROLLER PROGRAMMING INSTRUCTIONS

AUX Key  
(inoperable)

Set Key  
Press and release  
to display temper-  
ature set point



Up Arrow Key  
Press to increase temperature set point  
(1° increments)

Down Arrow Key  
Press to decrease temperature set point  
(1° increments)

The controller has been factory pre-set for an air temperature set point and a low temperature alarm set point. In most cases, these set points will not need to be changed. However, if changes are necessary, the controller is programmable.

Factory Preset Set Points	
Air Temperature	140°F
Air Temperature Operating Range	140° to 175°F

**To Lock or Unlock the Controller:** Press and hold both **Arrow Keys** at the same time for at least three seconds. "oF" will display when the controller is locked; "oN" will display when the controller is unlocked.

**To View the Temperature Set Point:** Press and release the SET button

**To Change the Temperature Set Point:** Turn power ON. Press and hold the SET button for 3 seconds. The current set point will display and "°F" will flash. Push the up or down arrow buttons to raise or lower the temperature set point in 1° increments. Push SET to store the new setting; the new temperature setting will flash 3 times and then the display will revert back to the actual temperature. (If set button is not pushed within 13 seconds, the new setting will be automatically set and the display will revert back to the actual temperature).

To Change from °F to °C, contact factory.

## DAILY CLEANING PROCEDURES



### CAUTION: ELECTRIC SHOCK HAZARD

Disconnect appliance from electric power before cleaning.



### CAUTION: HOT SURFACE

Exposed surfaces can be hot to the touch and may cause burns. Allow appliance to cool before cleaning.



### IMPORTANT:

DO NOT spill or pour water into controls, control panel or wiring. Water damage is **not** covered by the warranty.



### CAUTION:

Beware of sharp edges with sheet metal during cleaning process.



### CAUTION:

Do not use steel wool pads to clean cabinet. Ferrous deposits will cause rusting.

1. After all food products have been removed from the cabinet, turn the power switch to "OFF" and allow the cabinet to cool. If cabinet is supplied with a plug, disconnect from power prior to cleaning.
2. Remove the doors from by flipping up and lifting off. Doors should be washed with a clean damp cloth and chlorine-free detergent. Rinse thoroughly with clean damp cloth and allow to dry. Do not use scratch pads, abrasive cleaners, waxes, car polish, or substances containing strong aromatic solvents or alcohol. Do not use scratch pads or steel wool on the plastic doors. Do not use stainless steel cleaner.
3. Remove heat ducts by lifting up off of the rack posts and then sliding out. Using a clean damp cloth with appropriate cleaner (see page 9), clean the inside of the unit and the removed parts. Wipe any residue with clean damp cloth. Reinstall all parts when they are dry and clean.
4. Inspect and clean the areas where there are vents or filters, making sure no water gets into the internal controls or electrical areas of the cabinet.
5. Controller should be washed with a clean damp cloth and chlorine-free detergent. Rinse thoroughly with clean damp cloth and allow to dry. Do not use scratch pads, abrasive cleaners, waxes, car polish, or substances containing strong aromatic solvents or alcohol. Do not use stainless steel cleaner.

Doors; one on each side (flip up and lift off)

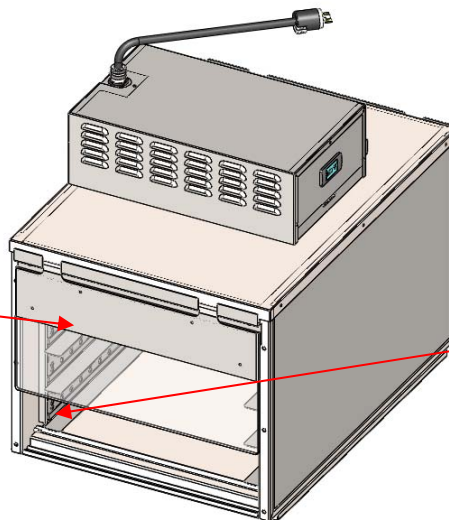

Pan shelves; heat ducts

## TIPS FOR CLEANING STAINLESS STEEL

### RECOMMENDED TIPS FOR CLEANING STAINLESS STEEL

<u>Purpose</u>	<u>Frequency</u>	<u>Cleaning Agent</u>	<u>Method of Application</u>
Routine cleaning	Daily	Soap, ammonia detergent and water	Sponge with cloth, rinse with clear water and wipe dry.
Smears/ Fingerprints	As needed	Stainless steel cleaner or similar products	Rub with soft cloth as directed on package. Rub in direction of grain of stainless steel. Do not use on vinyl trim.
Stubborn spots and stains	Daily as needed	Any chloride-free or phosphate-free cleaner	Apply with damp sponge or cloth. Rub in direction of grain of stainless steel. Rinse thoroughly, especially if cleaner contains chlorine bleach, do not use on vinyl trim.
Hard water spots	Daily as needed	Vinegar	Swab with cloth. Rinse with water and wipe dry.



### **CAUTION:**

Cleanders, detergents, degreasers, sanitizers, or bleaching agents that contain chlorides or phosphates will cause permanent damage to stainless steel products. The damage appears as pits, eruptions, voids, small holes, severe discoloration or dulling of the metal finish.

Water with high chloride content can also damage stainless steel. If unsure of your water quality, we recommend you have it tested. **THIS DAMAGE IS PERMANENT, COSTLY TO REPAIR, AND IS NOT COVERED BY THE WARRANTY.**

# WIRING DIAGRAM

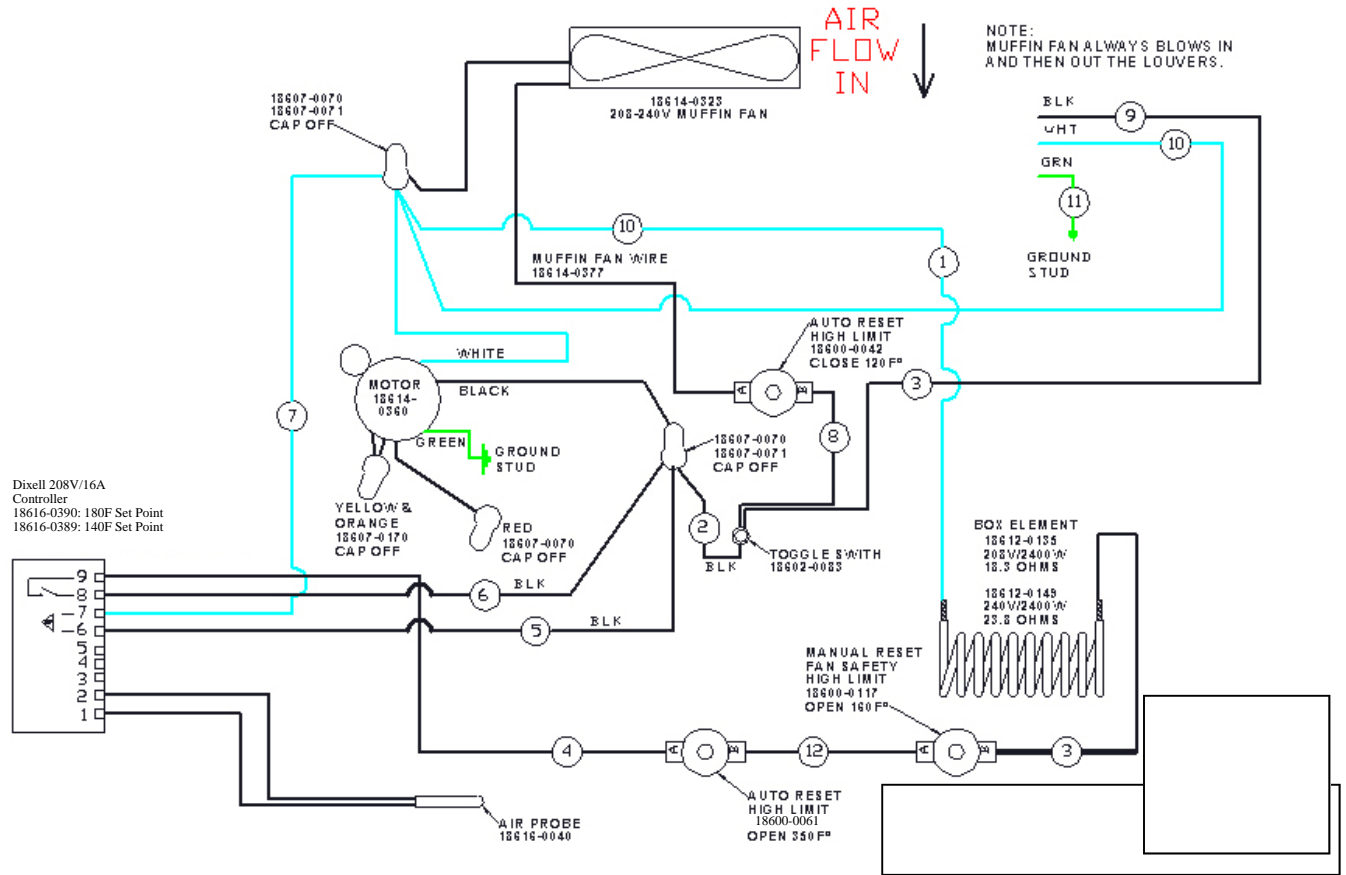

## REPLACEMENT PARTS LIST

PART NUMBER	DESCRIPTION
18600-0042	Hi Limit 120°F Snap Disc
18600-0061	Hi Limit 350°F Auto
18602-0031	Switch Boot
18602-0083	DPDT Toggle Switch
18612-0135	Heat Element 208V/2400W
18612-0149	Heat Element 240V/2400W
18614-0275	Fan Grill
18614-0323	Muffin Fan, 230V
18614-0360	Motor, 115/230V
18616-9996	Cord Grip
18614-0321	Blower Wheel

PART NUMBER	DESCRIPTION
18600-0117	Fan Safety Hi Limit 160°F w/Reset Snap Disc
18616-0389	Dixell 208V/16A 150°F Set-point Controller
16090-3594	HSJO 14/3 Cord with L6-16P Plug
18616-0040	20" Probe for EVO Heater
16095-3763	KFCEVOBH Plexiglass door

## TROUBLESHOOTING GUIDE

EVO Heater: 208VAC and 240VAC. Reference connections on wiring diagram (previous page)



**WARNING: All operations must be performed to requirements of NFPA-70E (Standard for Electrical Safety in the Workplace) by a qualified electrician. CALL FOR SERVICE.**

Symptom	Possible Cause	Remedy
No power; Dixell temperature controller display is not lit	Switch is not in ON position	Turn the switch ON
	Unit is not plugged in	Plug in the power cord
	Circuit breaker tripped	Reset the circuit breaker. If it trips again, disconnect the EVO heater and reset once more. When it trips, call an electrician to replace the breaker or replace the feeder. Otherwise, investigate for a short in the heater. Test: 1. Heating element A. 208V - 18 Ω B. 240V - 24Ω Replace if the difference is significant. 2. Blower motor—replace if necessary. Advice: When testing the motor, please pay attention to: body temperature (may be very hot!), rotor side wobbling, jammed rotor, partial or complete winding shortage.
	Power cord or plug is defective	Replace or repair
	Main switch is defective	Replace it
Dixell temperature controller display is not lit, but cooling fan is running	Defective thermostat Dixell	Check wires for crimping or looseness—correct if necessary
		Check wire connection on thermostat terminals #5 and #6—correct connection or replace the thermostat
Dixell temperature controller display is not lit	Cooling fan is not running	1. Check the fan's cable connection—correct if necessary 2. Cooling fan is defective—replace if necessary
Dixell Temperature controller display is lit, but the food chamber is not heated	Heating element is cold	1. Check wires for crimping or loose connection—correct if necessary 2. Check wire connections on Dixell temperature controller terminals #8 and #9—correct loose connection 3. Check Dixell temperature controller—replace if necessary 4. Check Hi Limit 350°F—correct connection or replace Hi Limit if necessary 5. Check heating element (see above) - replace the element if defective 6. Check Hi Limit 160°F. If the Hi Limit reset button has popped up, figure out reason, repair and reset.
	Heating element is hot. CAUTION: Heating element may reach temperature as hot as 650°F.	1. Blower fan is loose—tighten set screw or replace 2. Check blower motor: A. Motor is very hot: overheat protection activated; figure out why motor has overheated, correct it, cool down motor. Replace if the motor is faulty. B. Motor is cold: correct connections or replace motor or capacitor if necessary.

## TROUBLESHOOTING GUIDE - Continued

Symptom	Possible Cause	Remedy
Dixell temperature controller display is lit up and food chamber is overheated	Heating element is hot. <b>CAUTION:</b> Heating element may reach temperature as hot as 650°F	<ol style="list-style-type: none"> <li>Hi limit 350°F is always closed: measure temperature on it surface; replace Hi Limit if it is hotter than 325°F. <b>NOTE:</b> When the cover is open, the wire compartment, including the Hi Limit 350°F is naturally cooled.</li> <li>Dixell temperature controller is defective; replace controller</li> </ol>
Cooling fan does not operate	Cooling fan does not operate	<ol style="list-style-type: none"> <li>Check Hi Limit 120°F—replace if necessary</li> <li>Check cooling fan—replace if necessary. <b>NOTE:</b> The fan is controlled by Hi Limit of 120°F and starts when the temperature in the wire box is higher than 120°F. This can take up to 6 minutes. Also, the fan might run after turning the switch OFF, until the temperature falls under 120°F.</li> </ol>
No heat	Heater blower not running, heating element not energized. <b>WARNING:</b> heater blower may have failed	<ol style="list-style-type: none"> <li>Remove cover, press Hi Limit reset button on “FAN SAFETY” limit (Part Number: 18600-0117)</li> <li>Check operation of heater blower; replace if necessary. <b>NOTE:</b> this Hi Limit prevents an “over temp” situation INSIDE the control unit. Ensures proper air flow throughout heater and cooling fan operation.</li> </ol>

### HEAT LIMIT SWITCH RESET

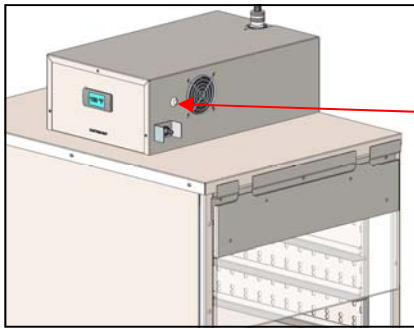

The KFCEVOSH is equipped with a temperature activated heat limit switch that will interrupt the power to the heater tubes if the temperature inside the control box exceeds 160°F (71°C). The HIGH LIMIT/RESET can be manually reset by pushing the button located on the side of the control box as shown.

- DISCONNECT UNIT FROM POWER SOURCE
- Check to see if the air intake fan is free of dust, grease or other obstructions. If there are, clean fan.
- Reset the heat limit switch.
- Plug unit back into proper power source and turn on.
- If unit does not operate properly call technical service for assistance.

### Temperature Controller Alarms—**CONTACT SERVICE IF YOU SEE ANY OF THESE ALARM CODES ON THE DISPLAY**

Display Reads	Indicates
P1	Air probe failure
HA	Maximum temperature alarm
LA	Low temperature alarm
EA	External alarm

**For technical assistance with troubleshooting, call Carter-Hoffmann at (800)421-3744 or (847)362-5500.**



**NOTE:** Prior to calling for service locate the serial tag on the cabinet. You will need the serial number of the cabinet for proper identification.

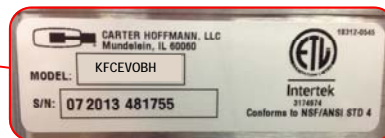

Cabinet serial tag

## WARRANTY

### ***Carter-Hoffmann Warranty:***

*Carter-Hoffmann ("CARTER-HOFFMANN") warrants to the initial purchaser of its standard Carter Line Products that CARTER-HOFFMANN will, at its option, repair or replace, during the warranty period set forth below, any part of such products made necessary due to a defect in material or workmanship which is present when the product leaves its factory and which manifests itself during the warranty period under normal use and service.*

*This warranty applies only to original equipment owned and possessed by the initial purchaser and the warranty period begins on the date of installation for two years on parts and labor.*

*Repair or replacements under this warranty will be performed, unless otherwise authorized in writing by CARTER-HOFFMANN, at its factory. All parts or components to be repaired or replaced under this warranty are to be shipped prepaid to CARTER-HOFFMANN, with reimbursement credit for such part or component to be given if found by CARTER-HOFFMANN to be defective.*

*CARTER-HOFFMANN neither makes nor assumes and does not authorize any other person to make or assume any obligation or liability in connection with its products other than that covered in this warranty. This warranty applies only within the continental United States and Canada. In Alaska and Hawaii, this warranty applies only to and is limited to the supply of replacement parts.*

### ***Warranty Exclusions and Limitations:***

*Any implied warranty of merchantability or fitness for a particular purpose is hereby specifically disclaimed by CARTER-HOFFMANN. There are no warranties, expressed or implied, which extend beyond the description on the face hereof. This warranty does not cover and CARTER-HOFFMANN shall not under any circumstances be liable for any incidental, consequential or other damages (such as injury to persons or property, loss of time, inconvenience, loss of business or profits, or other matters not specifically covered) arising in connection with the use of, inability to use, or failure of these products.*

***Specifications subject to change through product improvement and innovation.***

### ***Carter-Hoffmann***

**1551 McCormick Ave.**

**Mundelein, Illinois, 60060 USA**

**Phone: 847-362-5500 Toll free: 800-421-3744 Fax: 847-367-8981**

**Sales and Marketing E-mail: [sales@carter-hoffmann.com](mailto:sales@carter-hoffmann.com)**

**Service E-mail: [technicalservice@carter-hoffmann.com](mailto:technicalservice@carter-hoffmann.com)**

**Company Website: [www.carter-hoffmann.com](http://www.carter-hoffmann.com)**

**CFESA**

**Proud Member**

**NAFEM**  
North American Association of  
Food Equipment Manufacturers