

CAPPUCCINO, COFFEE, and SOUP DISPENSERS



GB-IT (Intelligent Technology)

- Microprocessor Technology
- Touch Pad Control Panel
- Free Flow and Portion Control
- Counts Total Number of Cups Dispensed
- Automatic Rinse Cycle
- Diagnostics for Electrical Problems
- Removable & Replaceable Picture easy – no assembly required

OPERATION MANUAL

- Specifications..... 2
- Installation and Operating Instructions..... 4
- Adjustments..... 6
- Programming Instructions..... 8
- Care and Maintenance..... 8
- Trouble Shooting Guide..... 11
- Parts Identification..... 15
- Wiring Diagrams..... 21

Cecilware sells value... Worldwide

45 -05 20th Avenue, Long Island City, NY 11105

TEL • 718-932-1414

FAX • 718-932-7860



MECHANICAL SPECIFICATIONS								
MODEL:	WIDTH in	DEPTH in	HEIGHT in	Lb (qty)	TANK GAL.	BURST CAPACITY	LIT DISPLAY AREA (W x H) Sq. in.	SHIPPG WEIGHT LB.
GB1M-IT	8.5	22	34	8 (1)	2.2	58	(7 x 13) 91	65
GB2M-5.5-IT	8.5	22	34	5.5 (2)	2.2	58	(7 x 13) 91	86
GB3M-5.5-IT	11	22	34	4 (3)	3.2	85	(9½ x 13) 123	100
GB3M-5.5-IT S/S	11	22	34	5.5 (3)	3.2	85	(9½ x 13) 123	100
GB3M-IT-10 LEFT [11.5"W]	11.5	22	34	10 (1) + 5.5 (2)	4.5	112	(12¾ x 13) 164	110
GB3M-IT-10 RIGHT [11.5"W]	11.5	22	34	10 (1) + 5.5 (2)	4.5	112	(12¾ x 13) 164	110
GB4M-IT	14.125	22	34	5.5 (4)	4.5	112	(12¾ x 13) 164	120
GB5M-IT	17.25	22	34	5.5 (5)	4.5	140	(12¾ x 13) 164	140

ELECTRICAL SPECIFICATIONS								
Model No.	Volts	Phase	HZ	Watts	Number of Heaters	Amps	Receptacle Nema No.	Circuit Breaker
ALL MODELS	120V	1	60	1.8KW	1	15	5-15R	15A
ALL MODELS	120/240V	1	60	3.0KW	1	15	L14-20R**	20A
ALL EXPORT MODELS	220V	1	60	3.0KW	1	15	††	20A
GB3M-5.5-IT, GB4M-5.5-IT	120/240V	1	60	6.0KW	2	25	L14-30R**	30A

120V, 1.8 KW, 15A, Nema 5-15R standard on all models; 3.0 KW and 6.0 KW, 120/240V units available
 ** 120/240V, 3 pole, 4 wire grounding type Twist-Plug Receptacle. For 240V units, Use L6-20R or L6-30R, 2 pole, 3 wire Twist-Plug Receptacle.
 †† 220V Export Receptacle to be specified where order is placed.
 See Electrical Data Label attached to the back of the unit for proper voltages, breaker sizes and electrical outlet requirements for each model number listed. See wiring diagram in back of manual, for wiring instructions.

UNPACKING INSTRUCTIONS

Carefully unpack the GB Machine and inspect immediately for shipping damage. Your GB Machine was shipped in a carton designed to give it maximum protection in normal handling. It was thoroughly inspected before leaving the factory. In case of damage, contact the shipper, not Cecilware.

INSTALLATION INSTRUCTIONS

Water Inlet Connection:

This equipment is to be installed to comply with the applicable Federal, State, or local plumbing codes having jurisdiction. In addition:

1. A quick disconnect water connection or enough extra coiled tubing (at least 2x the depth of the unit) so that the machine can be moved for cleaning underneath.
2. An approved back flow prevention device, such as a double check valve to be installed between the machine and the water supply.

The GB beverage dispenser is equipped with a ¼" Flare Water Inlet Fitting which is located on the left side in the back of the base.

HIGHLY RECOMMENDED:

A WATER SHUT-OFF VALVE and A WATER FILTER, preferably a combination Charcoal/Phosphate Filter, to remove odors and inhibit lime and scale build up in the machine. **Note: In areas with extremely hard water, a water softener must be installed in order to prevent a malfunctioning of the equipment and in order not to void the warranty.**

After the machine has been unpacked and placed on a counter, pull out the stainless steel drip tray. It should contain the following:
 A Set of 4 Adjustable Leveling Legs & Water Inlet Fitting.

START-UP PROCEDURE

1. Connect the ¼" dia. copper waterline to the ¼" flare water inlet fitting of the valve.
2. Plug the power cord into a proper receptacle.
3. Activate the **Power Switch** (Toggle Up) located on the right side of the splash panel below the door. The power switch controls all power to the machine including the heater elements. The door display panel will light up and the tank will start filling. The LCD window will display this message briefly "CECILWARE, DISPENSER V#.#.#".
4. The LCD window will display this message "**Low Water Level**". Allow approximately 3-5 minutes for the tank to fill. If the tank does not fill up within the first 5 minutes an error message will appear in the CD window [SYSTEM ERROR, FILL RESPONSE]. See Definition of Screen and Troubleshooting Guide.
5. The LCD window will display this message "**Low Water Temp.**" Allow up to 30 minutes for the water to reach a temperature of 190°F. The heat up time will depend on the water inlet temperature, the input voltage and the wattage of the elements in the machine.

While the tank is heating up, remove the hoppers, load them with products and reposition them back in the machine. Be sure to reposition the hoppers so that the 1/4" pin slides into the hole of the compartment base.

When the machine has reached the proper dispensing temperature, the LCD window will display one of these messages:

IF THE RINSE MODE IS ON

IF THE RINSE MODE IS OFF

PLEASE RINSE
TO CONTINUE

OR

PLEASE SELECT
CHOICE OF DRINK

To Rinse press simultaneously the Rinse/Blue Button & Green Button for each hopper.

6. To Dispense a Cup of Cappuccino or Soup: Place a 8 oz. or larger cup under selected drink dispense nozzle. Press Dispense/Green Button.
For units set for "free flow": Push and hold Green button until cup is 2/3 full, then release button.
For units set for "portion control": Press and Release Green Button. Cup will fill up automatically to it's preset amount.
The machine is factory preset to dispense water at the rate of 1 oz./sec. for Cappuccino and 1.3 oz./sec. for Soup.
This flow rate corresponds with the factory preset cup sizes [small 6 oz.] [medium 8 oz.] [large 12 oz.].
To adjust the Water Flow Rate on the Dispense Valve see Illustration B.
See **Programming Instructions** if different levels of drink strength are desired or different cup sizes are desired.

TO CHECK VOLUME AND GRAM THROW DISPENSED (RATIO):

NOTE: These GB units have a fixed speed Auger Motor CD150 [95 RPM] and dispenses powder at a constant fixed rate.

The water flow rate should not exceed 1.3 oz./sec. This may cause overflow in the mixing chamber/cup.

- a. Remove the product guide from the hopper and position a receptacle under the hopper nozzle to catch the gram throw of product.
- b. Also place a measuring cup under extension tube to catch the water dispensed.
- c. Push the dispense button and check the amount of product dispensed, amount of water dispensed, and time [use stop watch] to dispense that water.
- d. The amount of of water dispensed in the measuring cup divided by the time required to dispense that water is the Water Flow Rate from Dispense Valve. If the amount [oz.] of water dispensed is different from the programmed amount [oz.] for Cup Size, then adjust the Water Flow Rate from Dispense Valve. See illustration B.

FOR CAPPUCCINO:

The machine is factory adjusted to dispense 4-4.5 gr./sec. per OZ. Cup. [32 grams Product per 8 oz. cup]

The recommended throw is 28-32 grams per 8 oz. cup for Cappuccino, with 80% fill.

FOR COFFEE:

The machine is factory adjusted to dispense 0.3 gr./sec per OZ. Cup. [1.5 grams of coffee product per 5 oz. of liquid (in a 6 oz. cup).

The recommended throw is 1.5 to 1.8 grams per 6 oz. cup of Coffee, with 80% fill.

FOR SOUP:

The machine is factory preset to specified customer requirements, because the gram throw for each soup flavor and type varies considerably with the consistency of each product. Adjustments can also be made by the customer, as shown above and by programming the desired amounts. *For customer specified/special settings see insert.*

GB3M-5.5-IT DIMENSIONS & COMPONENTS LOCATION - ILL. A

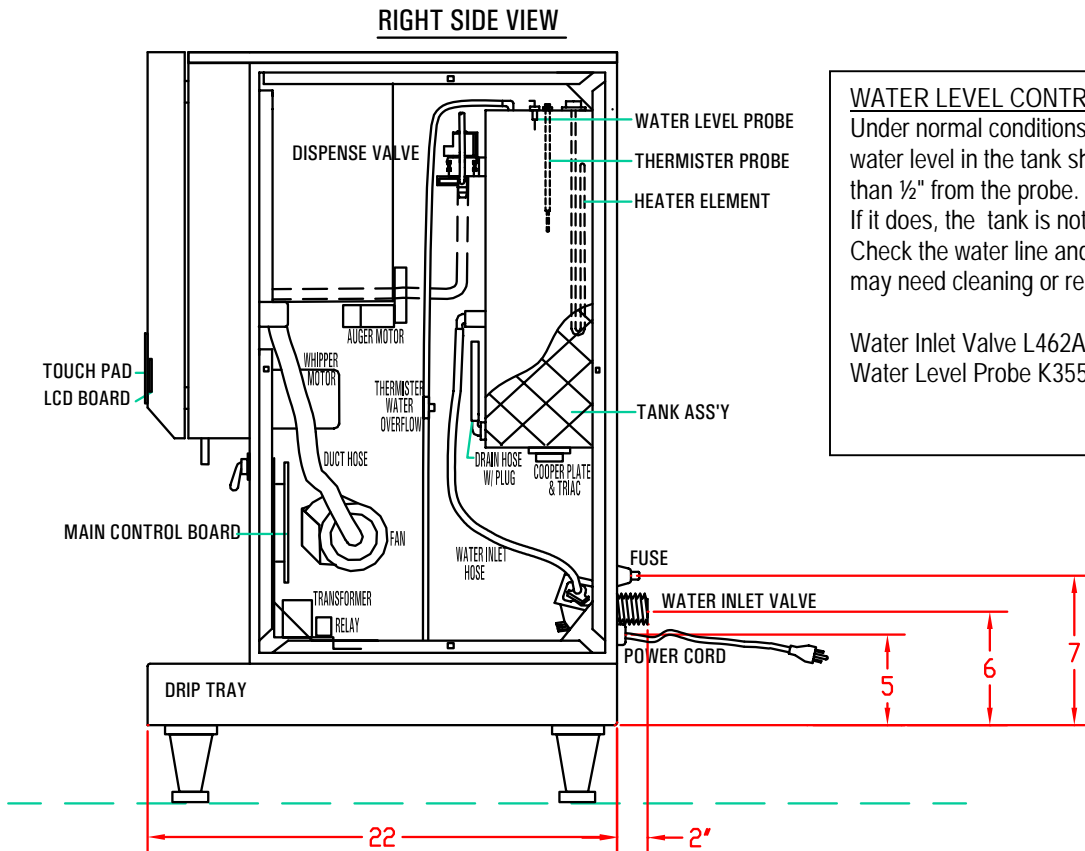
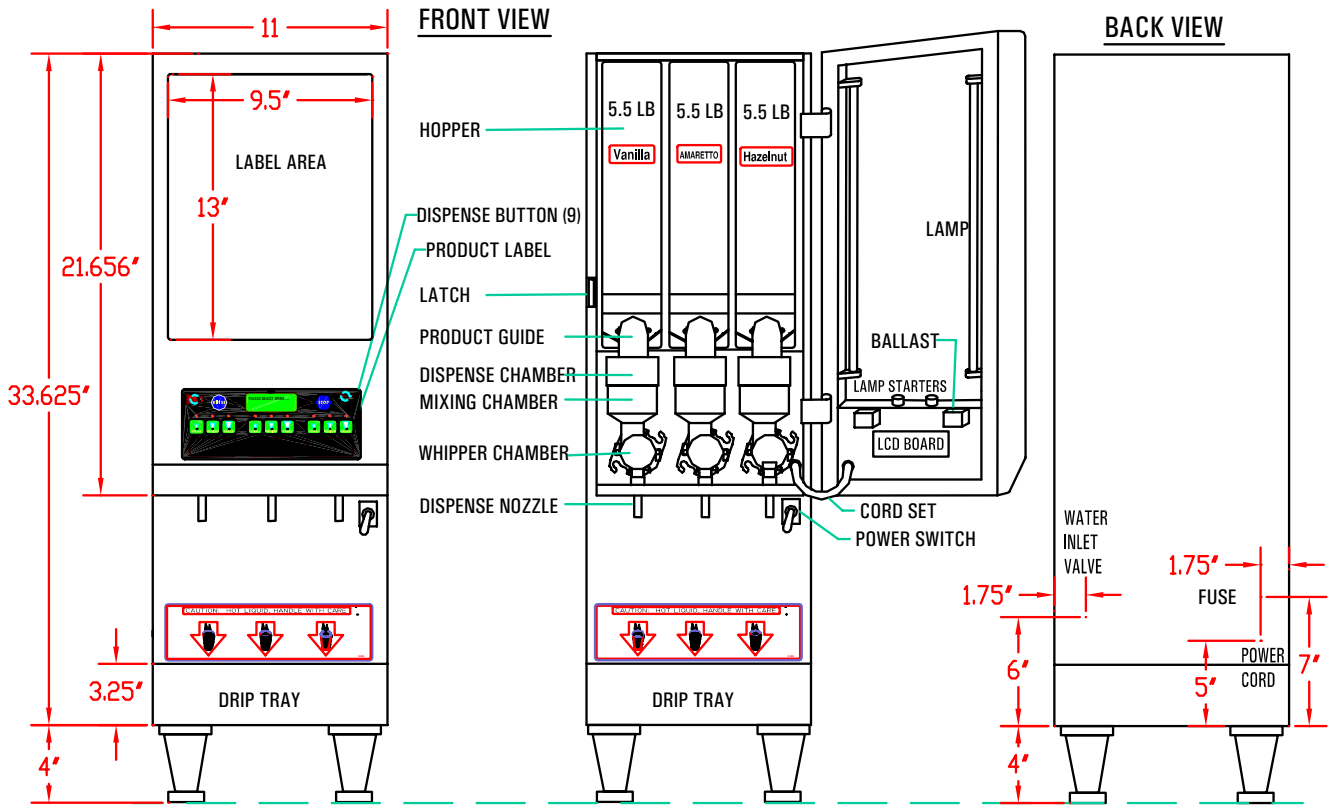

WATER LEVEL CONTROLS:
 Under normal conditions and operation, the water level in the tank should not drop more than 1/2" from the probe. If it does, the tank is not refilling fast enough. Check the water line and water filter, they may need cleaning or replacing.

Water Inlet Valve L462A
 Water Level Probe K355Q [K402A & P410A]

ADJUSTMENTS - ILL. B

WATER FLOW RATE

The Dispense Valves are factory adjusted for a maximum Flow Rate of 1 to 1.3 oz./sec.
 [Approximate settings: 0.85 to 1 oz./sec for SOUP; 1.3 oz./sec. for COFFEE and CAPPUCCINO]
 Exceeding this Flow Rate will cause the Mixing Chamber to overflow.
 Note: To access the Water Dispense Valves, open door and remove Hoppers.

TO ADJUST WATER FLOW RATE:

1. Open door and remove hoppers. Locate Dispense Valve behind hoppers, mounted on tank.
2. Locate adjustment screw on Dispense Valve.
3. Using Allen Key or flat screwdriver rotate, 1/4 turn at a time, CLOCKWISE to decrease water flow, or to increase water flow.
4. Check water flow output, after each 1/4 turn.

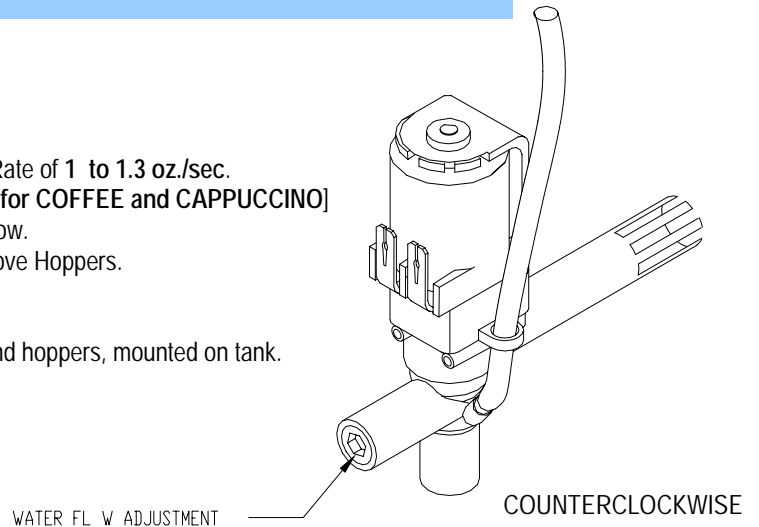

HOPPERS AND AUGERS

CD130 NYLON AUGER [22.5mm% ϕ X 17mmPT]
 W/O-RING CD139

CD101 WIRE AUGER [22.5mm% ϕ X 17mmPT]
 CAPPUCCINO/FAST FLOW & SOUP

CD149 WIRE AUGER [22.5mm% ϕ X 24.8mmPT]
 HOT CHOCOLATE & THICK SOUP

CD74A WIRE AUGER [17mm% ϕ X 12mmPT]
 DRY COFFEE/FAST FLOW

CD153 WIRE AUGER [17mm% ϕ X 9.15mmPT]
 DRY COFFEE & INSTANT ESPRESSO

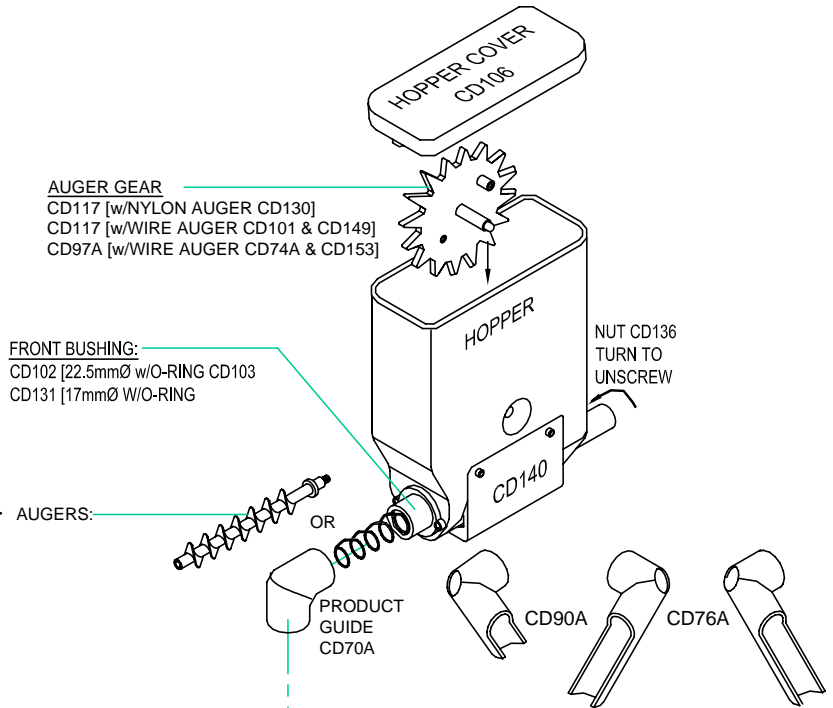

A. When using NYLON AUGERS:
 Adjust Water Flow Rate so that the water level reaches almost at the top in the Mixing Chamber, as shown.

B. When using WIRE AUGERS:
 Adjust Water Flow Rate so that the water level reaches half way up in the Mixing Chamber, as shown.

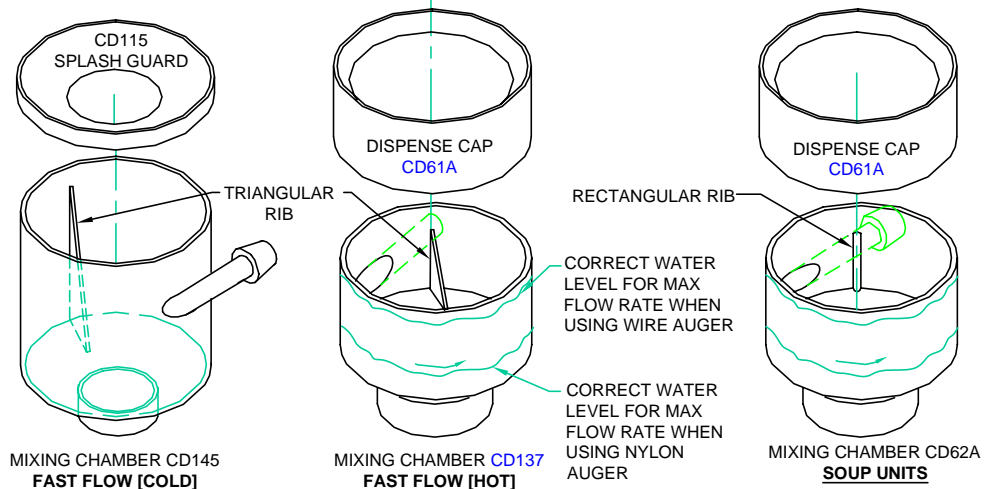

Features and Benefits of the Digital Dispenser Controller

1. 100% Solid State Control for improved reliability
2. Modular design and reduced component count for ease of service
3. Optional sanitary features such as Rinse Lockouts and Rinse Warnings
4. Redundant system interlocks for uncompromising user safety
5. Large two line display for viewing system status and modifying parameters
6. Individual dispense counters and totalizers for product marketing information and inventory control
7. Advanced system diagnostics that continuously monitor the status of all motors, solenoids, sensors, and heaters to ensure proper operation and aid in identifying potential problems
8. Protection from heater burnout due to lack of water in the reservoir tank
9. Elimination of dry powder feed at the beginning of a dispense and product dilution at the end of a dispense
10. Extremely accurate dispensing control utilizing DC servo-motor drive technology
11. Stable water temperature regulation with an adjustment resolution of one-degree Fahrenheit
12. Optional Low Water Temperature Lockout to prevent dispensing at water temperatures below an adjustable threshold
13. Units of measure displayed in either English or Metric
14. Digital adjustment of serving sizes with a resolution of one-tenth of an ounce
15. Digital adjustment of gram throw with a resolution of one-percent-of-maximum
16. Audible alarm
17. User selectable "Portion Control" or "Free Flow" dispense modes
18. Optional power saving "sleep mode" for extended periods of inactivity
19. Easy to use menu-driven dispensing and rinsing instructions
20. Optional Teach-Me method of setting serving size
21. Several "engineering functions" designed to speed new product development
- 22.

PARAMETER DEFINITIONS FOR SYSTEM SOFTWARE VERSION 1.11

1. **Grand Total** – This parameter indicates the total amount of water dispensed (in ounces or milliliters) for the entire machine. The Grand Total does not include Rinse Dispenses. The maximum Grand Total value is 16,777,216 ounces; after which the value will begin again from zero. This parameter cannot be reset to zero. Default Values has no effect on this parameter.
2. **Dispense Total** – This parameter indicates the total amount of water dispensed (in ounces or milliliters) for a selected hopper. The Dispense Total does not include Rinse Dispenses. The maximum Dispense Total value is 16,777,216 ounces; after which the value will begin again from zero. This parameter cannot be reset to zero. Default Values has no effect on this parameter.
3. **Dispense Counter** – This parameter indicates the total number of cups dispensed for a selected Serving Size. The Dispense Counter does not include Rinse Dispenses. The maximum Dispense Counter value is 49,999; after which the value will begin again from zero. In Service Mode this parameter can be reset to zero by simultaneously depressing the and Keys. Default Values has no effect on this parameter.
4. **Dispense Mode** – This parameter determines whether the system dispenses in a continuous (Free Flow) or fixed size (Portion Control) method. The default setting for this parameter is Portion Control.
5. **Serving Size** – This parameter determines the amount of water dispensed for each Dispense Key when the Dispense Mode is set to Portion Control. The default settings are as follows: Small = 6.0 ounces, Medium = 8.0 ounces, Large = 12.0 ounces. The minimum Serving Size is 2.0 ounces. The maximum Serving Size is 64.0 ounces.
6. **Gram Throw** – This parameter determines the ratio of product to water during a Dispense for a selected Hopper. The units of measure for Gram Throw are proportional to Auger Turns per ounce of water. At a Fill Constant of 1.00 ounces per second the maximum Gram Throw is 100 and the minimum Gram Throw is 20. The maximum and minimum values are scaled proportional to a Fill Constant of 1.00 ounces per second. For example: if the Fill Constant is set to 1.30 ounces per second the maximum Gram Throw would be $(100 \times 1.00) / 1.3 = 77$. This prevents the user from requesting a Gram Throw that is beyond the capability of the Auger Motor. Auger Start and Stop Times have no effect on this parameter. The default setting for this parameter is 75.
7. **Auger Start Time** – This parameter sets the time that the Auger starts to turn relative to the activation (opening) of the Dump Valve. A positive value indicates an Auger starting at some time after the opening of the Dump Valve. A negative number indicates an Auger starting at some time before the opening of the Dump Valve. The minimum Auger Start Time = (-3.0) seconds. The maximum Auger Start Time is 3.0 seconds. The default value for this parameter is 0.3 seconds.
8. **Mixer Start Time** – This parameter sets the time that the Mixer starts to turn relative to the activation (opening) of the Dump Valve. A positive value indicates a Mixer starting at some time after the opening of the Dump Valve. A negative number indicates a Mixer starting at some time before the opening of the Dump Valve. The minimum Mixer Start Time = (-3.0) seconds. The maximum Mixer Start Time is 3.0 seconds. The default value for this parameter is 0.3 seconds.
9. **Auger Stop Time** – This parameter sets the time that the Auger stops turning relative to the de-activation (closing) of the Dump Valve. A positive value indicates an Auger stopping at some time after the closing of the Dump Valve. A negative number indicates an Auger stopping at some time before the closing of the Dump Valve. The minimum Auger Stop Time = (-3.0) seconds. The maximum Auger Stop Time is 3.0 seconds. The default value for this parameter is 0.3 seconds.
10. **Mixer Stop Time** – This parameter sets the time that the Mixer stops turning relative to the de-activation (closing) of the Dump Valve. A positive value indicates a Mixer stopping at some time after the closing of the Dump Valve. A negative number indicates a Mixer stopping at some time before the closing of the Dump Valve. The minimum Mixer Stop Time = (-3.0) seconds. The maximum Mixer Stop Time is 3.0 seconds. The default value for this parameter is 0.6 seconds.
11. **Fill Constant** – This parameter is set to the actual Fill Rate of all of the Dump Valves. All Dump Valves in a system must be adjusted so that they have equal Fill Rates. The maximum Fill Constant is 4.00 ounces per second. The minimum Fill Constant is 0.50 ounces per second. The maximum and minimum values are scaled proportional to a Gram Throw of 100. For example: if the highest Gram Throw setting is 77 then the maximum Fill Constant would be $(100 \times 1.00) / 77 = 1.30$. This prevents the user from requesting a Gram Throw that is beyond the capability of the Auger Motor. The default setting for this parameter is 1.30 ounces per second.
12. **Rinse Dispense Time** – This parameter determines the amount of time that the Dump Valve is open during a Rinse Cycle. The minimum Rinse Time = 3 seconds. The maximum Rinse Time is 15 seconds. The default value for this parameter is 6 seconds.

13. **Rinse Warning Status** – This parameter determines whether the Rinse Warning Option is turned ON or OFF. If this option is ON the system generates a Rinse Warning if a Hopper has dispensed and has not been Rinsed for of time greater than that defined by (50 * Rinse Lockout Time) minutes. For example: If the Rinse Warning Status is ON and the Rinse Lockout Time is 6 Hours then a Rinse Warning will be generated when a Hopper is not Rinsed for more than (50 * 6 = 300) minutes (5 hours). Generating a Rinse Warning will cause the audible alarm to sound for two seconds and the Rinse Warning Screen to be displayed for five seconds. The system will then revert back to normal operation. If the offending Hopper is not rinsed after the first Rinse warning additional Rinse Warnings will be generated every five minutes until the respective Hopper is rinsed. The default setting for this parameter is OFF.
14. **Rinse Lockout Status** - This parameter determines whether the Rinse Lockout Option is turned ON or OFF. If this option is ON the system generates a Rinse Lockout if a Hopper has dispensed and has not been Rinsed for a period of time greater than that defined by the Rinse Lockout Time. Once a Hopper enters Rinse Lockout the LED's of the Dispense Keys related to that Hopper will turn OFF thus indicating that the Hopper will no longer dispense. The default setting for this parameter is OFF.
15. **Rinse Lockout Time** – This parameter determines the length of time required before entering Rinse Lockout. The minimum Rinse Lockout Time = 1 hour. The maximum Rinse Lockout Time is 12 hours. The default value for this parameter is 6 hours.
16. **Water Temperature Set Point** – This parameter determines the required reservoir tank water temperature. The minimum Water Temperature Set Point is 140°F. The maximum Water Temperature Set point is 203°F. The default value for this parameter is 190°F.
17. **Low Water Temperature Lockout Status** – This parameter determines whether the Low Water Temperature Lockout Option is turned ON or OFF. If this option is ON the system generates a Low Water Temperature Lockout if the present water temperature is below the value defined by the Low Water Temperature Lockout Set Point. Once a Hopper enters Low Water Temperature Lockout, all of the Dispense Key LED's will turn OFF thus indicating that the system will no longer dispense. The default setting for this parameter is ON.
18. **Low Water Temperature Lockout Set Point** – This parameter determines the minimum reservoir tank water temperature allowed before entering Low Water Temperature Lockout. The minimum Low Water Temperature Lockout Set Point is 125°F. The maximum Low Water Temperature Lockout Set point is 203°F. The default value for this parameter is 140°F.
19. **Sleep Mode Status** – This parameter determines whether the Sleep Mode Option is turned ON or OFF. If this option is ON and the system has not dispensed for four hours the system will enter Sleep Mode. Once in Sleep Mode the system will reduce the required Water Temperature to equal that defined by (10°F + Low Water Temperature Lockout Set Point). The default setting for this parameter is OFF.
20. **Hopper Status** – This parameter determines the whether a selected Hopper is turned ON or OFF. If a Hopper is ON then the Auger Motor, Mixer Motor, and Dump Solenoid status checking is enabled and the Hopper is allowed to dispense. If a Hopper is OFF then Auger Motor, Mixer Motor, and Dump Solenoid status checking is disabled and the LED's of the Dispense Keys related to that Hopper will turn OFF thus indicating that the Hopper will no longer dispense. The default setting for this parameter is OFF.
21. **Auger Status** – This parameter determines whether the Auger Motor of the selected Hopper is turned ON or OFF. If an Auger Motor is ON then dispenses from the selected Hopper will include powder (product). If an Auger Motor is OFF then dispenses from the selected Hopper will not include powder (product). This is a temporary parameter and is reset to the default setting at "power-on". The default setting for this parameter is ON.
22. **Mixer/Dump Status** – This parameter determines whether the Mixer/Dump (combination of the Mixer Motor and Dump Solenoid) of the selected Hopper is turned ON or OFF. If a Mixer/Dump is ON then dispenses from the selected Hopper will mix and will include water. If a Mixer/Dump is OFF then dispenses from the selected Hopper will not mix and will not include water. This is a temporary parameter and is reset to the default setting at "power-on". The default setting for this parameter is ON.
23. **Displayed Units** – This parameter determines whether the displayed units of measure are English or Metric. If the Displayed Units parameter is set to English then all temperatures are displayed as Degrees Fahrenheit and all volumes are displayed as Fluid Ounces. If the Displayed Units parameter is set to Metric then all temperatures are displayed as Degrees Celsius and all volumes are displayed as Milliliters. The default setting for this parameter is English.
24. **Dispense Type** – This parameter determines whether the customer is prompted to select a choice of Drink or choice of Soup. If the Dispense Type is set to Drink then the instructional prompt will read "PLEASE SELECT CHOICE OF DRINK". If the Dispense Type is set to Soup then the instructional prompt will read "PLEASE SELECT CHOICE OF SOUP". The default setting for this parameter is Drink.

25. **Default Parameters** – This screen gives the user the ability to reset all system parameters except the Grand Total, Dispense Total, and Cups Dispensed. Simultaneously depressing the **RINSE** and **STOP** keys will force all system parameters to revert to designated individual default settings.
- *Important Note*** The default status for all Hoppers is OFF. Thus before any Hopper will dispense the Hopper Status must be manually set to ON.

PROGRAMMING INSTRUCTIONS – ILL. C

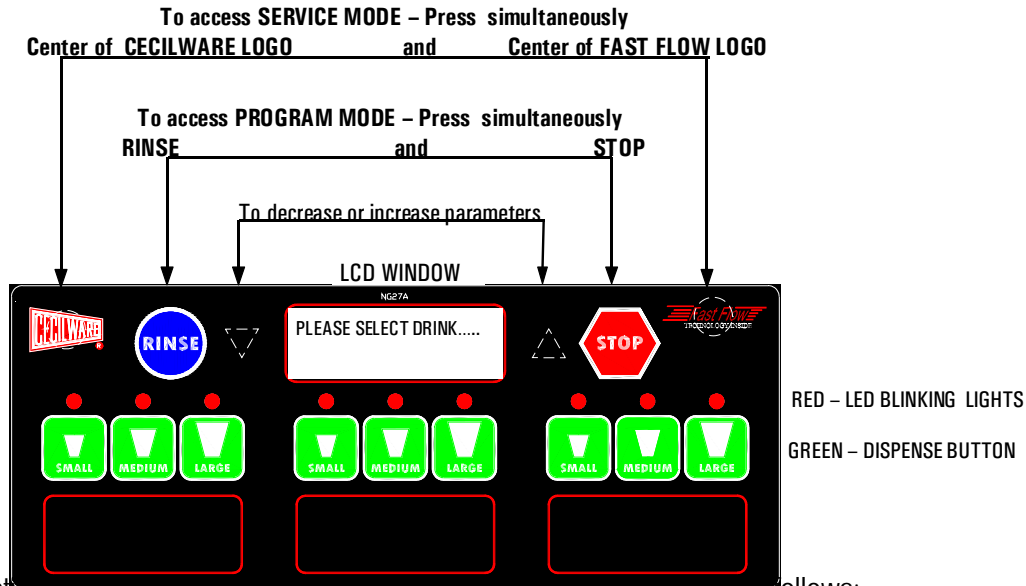

The a functional description of version 1.07 of the dispensing controller is as follows:

MODES OF OPERATION

- Initializing Mode** – This mode is only active during the first few seconds after a “power-on” or system reset. The main function of this mode is to configure the system using the previously saved operating parameters.
- Normal Mode** – This mode becomes active immediately after Initializing Mode has completed its tasks. The main functions of this mode are to monitor and report system status and control dispensing.
- Rinse Mode** – This mode becomes active when the *Rinse* key is depressed while in Normal Mode. The main function of this mode is to allow the operator to initiate an individual Rinse for any enabled Hopper.
- Program Mode** – This mode becomes active when the *Rinse* and the *Stop* keys are simultaneously depressed for more than 1.5 seconds while in Normal Mode. The main function of this mode is to provide limited access to frequently used system parameters.
- Service Mode** – This mode becomes active when the hidden keys under the “Cecilware Logo” and the “Fast Flow Logo” are simultaneously depressed for more than 1.5 seconds while in Normal Mode. The main function of this mode is to allow access to all system parameters that can be modified.

INITIALIZING MODE

The following screen signifies this presence of this mode:
It should be noted that this is the only time the System Software Version Number (V #.##) is displayed.
All other functions of this mode are completely transparent to the operator.

CECILWARE
DISPENSER V #.##

NORMAL MODE

The following is a list of functions performed by this mode:

- Dispensing Control** – This mode is responsible for implementing and supervising the dispensing process.
- Water Level Control** – This mode is responsible for maintaining the proper level of water in the reservoir tank.
- Water Temperature Control** – This mode is responsible for maintaining the required water temperature in the reservoir tank.
- Sanitary (Rinse) Functions** – This mode is responsible for annunciating and enforcing rinse warnings and lockouts.
- Safety Functions** – This mode is responsible for monitoring all sensors, motors, solenoids, and heaters for proper operation.

RINSE MODE

An individual Rinse is initiated by simultaneously pressing the *Rinse* key and a *Dispense* key corresponding to the hopper to be rinsed.

PROGRAM MODE

General Conventions (unless otherwise indicated)

1. To enter or exit Program Mode simultaneously depress both the *Rinse* key and the *Stop* key until the buzzer sounds (approximately 1.5 seconds).
2. Pressing the *Stop* key will cause the menu to scroll up and pressing the *Rinse* key will cause the menu to scroll down.
3. The blinking LED's signify which Hopper or Serving Size the displayed parameter corresponds to.
4. Pressing the ▼ or ▲ keys individually will decrease or increase the displayed parameter respectively.
5. Pressing the ▼ and ▲ simultaneously will cause the parameter to revert to a default value.

Functions:

1. All Dispense LED's will be illuminated and the LCD/VFD screen will display the following:

DISPENSE TOTAL
SELECT A KEY

2. If the *Stop* key is pressed the LCD/VFD screen will display the following:

DISPENSE TOTAL
#####.# OZ.

3. Pressing any of the *Dispense* keys will cause the *Dispense* LED of the corresponding key to blink and the LCD/VFD screen will display the serving counter for the indicated *Dispense* key as follows:

SERVING COUNTER
SELECT A KEY

4. Pressing any of the *Dispense* keys will cause the *Dispense* LED of the corresponding key to blink and the LCD/VFD screen will display the **Serving Counter** for the indicated *Dispense* key as follows:

SERVING COUNTER
CUPS

5. If the *Stop* key is pressed the LCD/VFD screen will display the following:
6. If the ▼ or ▲ keys are pressed the Dispense Mode will toggle between "free flow" and "portion control".

DISPENSE MODE FREE FLOW	DISPENSE MODE PORTION CONTROL
-------------------------------	----------------------------------

7. If the *Stop* key is pressed the LCD/VFD screen will display the following:

TEACH-ME SETUP
ARE YOU SURE ?

8. Pressing the ▼ and ▲ keys simultaneously will cause the menu to display the following:

TEACH-ME SETUP
SELECT A KEY

Teach Me Timer Setup

- A. Place cup or decanter under the desired nozzle.
 - B. Press one of the illuminated *Dispense* keys corresponding to the selected nozzle to begin dispensing.
 - C. Release the *Dispense* key to stop dispensing.
 - D. Wait a short time to allow the foam to settle.
 - E. Jog the *Dispense* key as needed to top off cup or decanter.
 - F. If desired simultaneously press the ▼ and ▲ keys to use the last Serving Size for all equal cup sizes.
- Repeat steps A-F for each *Dispense* key as required.

9. If the *Stop* key is pressed the LCD/VFD screen will display the following:

SERVING SIZE
SELECT A KEY

10. Pressing any of the *Dispense* keys will cause the *Dispense* LED of the corresponding key to blink and the LCD/VFD screen will display the Serving Size for the indicated *Dispense* key as follows:

SERVING SIZE
##.# OZ.

11. Pressing ▼ or ▲ key will decrease or increase the **Serving Size** respectively.

12. If the *Stop* key is pressed the LCD/VFD screen will display the following:

GRAM THROW
SELECT A KEY

13. Pressing any of the *Dispense* keys will cause the *Dispense* LED(s) of the corresponding Hopper to blink and the LCD/VFD screen will display the **Gram Throw** for the indicated Hopper as follows:



14. Pressing ▼ or ▲ key will decrease or increase the Gram Throw respectively.

15. If the *Stop* key is pressed the LCD/VFD screen will display the following:



16. Pressing any of the *Dispense* keys will cause the *Dispense* LED(s) of the corresponding Hopper to blink and the LCD/VFD screen will display the Status for the indicated Hopper as follows:



17. If the ▼ or ▲ keys are pressed the Hopper Status will toggle between “on” and “off”.

Note: IF either the **Auger Motor**, or **Mixer Motor**, or **Solenoid Error Screen** appear: **The entire system is inoperable** this means that one of either the Auger Motor, or Mixer Motor, or Solenoid [Dispense Valve] is not functional while that Hopper Status is ON.

To continue operating the other Hoppers: Press RINSE, Press ▼ or ▲ key until you get the HOPPER STATUS screen, Set the non-functional HOPPER STATUS to OFF, Wait at least 10 sec., then Exit program.

SERVICE MODE

General Conventions:

- To enter or exit Service Mode simultaneously depress both the hidden key behind the **Cecilware Logo** and the hidden key behind the **Fast Flow Logo** until the buzzer sounds (approximately 1.5 seconds).
- Pressing the *Stop* key will cause the menu to scroll up and pressing the *Rinse* key will cause the menu to scroll down.
- The blinking LED(s) signify which Hopper or Serving Size the displayed parameter corresponds to.
- Pressing the ▼ and ▲ keys individually will decrease or increase the displayed parameter respectively.
- Pressing the ▼ and ▲ keys simultaneously will cause the parameter to revert to a default value.

Functions:

1. All Dispense LED's will be illuminated and the LCD/VFD screen will display the following:

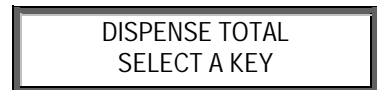

2. Pressing any of the *Dispense* keys will cause the *Dispense* LED of the corresponding key to blink and the LCD/VFD screen will display the serving counter for the indicated *Dispense* key as follows:

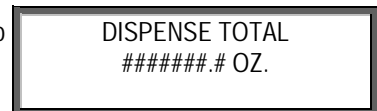

3. Pressing the ▼ and ▲ keys simultaneously will reset the **Dispense Total** for the indicated Hopper.

4. If the *Stop* key is pressed the LCD/VFD screen will display one of the following:



5. Pressing any of the *Dispense* keys will cause the *Dispense* LED of the corresponding key to blink and the LCD/VFD screen will display the **Serving Counter** for the indicated *Dispense* key as follows:

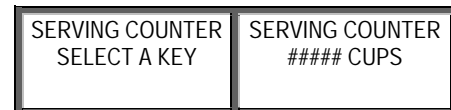

6. Pressing the ▼ and ▲ keys simultaneously will reset the **Serving Counter** for the indicated *Dispense* key.

7. If the *Stop* key is pressed the LCD/VFD screen will display the following:

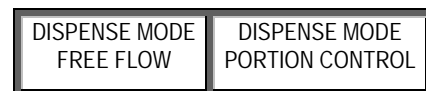

9. If the *Stop* key is pressed the LCD/VFD screen will display the following:

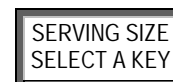

10. Pressing any of the *Dispense* keys will cause the *Dispense* LED of the corresponding key to blink and the LCD/VFD screen will display the **Serving Size** for the indicated *Dispense* key as follows:

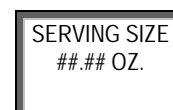

11. If the *Stop* key is pressed the LCD/VFD screen will display the following:

GRAM THROW
SELECT A KEY

12. Pressing any of the *Dispense* keys will cause the *Dispense* LED(s) of the corresponding Hopper to blink and the LCD/VFD screen will display the **Gram Throw** for the indicated Hopper as follows:

GRAM THROW
###

13. If the *Stop* key is pressed the LCD/VFD screen will display the following:

AUGER START TIME
SELECT A KEY

14. Pressing any of the *Dispense* keys will cause the *Dispense* LED(s) of the corresponding Hopper to blink and the LCD/VFD screen will display the **Auger Start Time** for the indicated Hopper as follows:

AUGER START TIME
SEC.

15. If the *Stop* key is pressed the LCD/VFD screen will display the following:

MIXER START TIME
SELECT A KEY

16. Pressing any of the *Dispense* keys will cause the *Dispense* LED(s) of the corresponding Hopper to blink and the LCD/VFD screen will display the **Mixer Start Time** for the indicated Hopper as follows:

MIXER START TIME
SEC.

17. Pressing any of the *Dispense* keys will cause the *Dispense* LED(s) of the corresponding Hopper to blink and the LCD/VFD screen will display the **Auger Stop Time** for the indicated Hopper as follows:

AUGER STOP TIME
SELECT A KEY

18. If the *Stop* key is pressed the LCD/VFD screen will display the following:

AUGER STOP TIME
SEC.

19. If the *Stop* key is pressed the LCD/VFD screen will display the following:

MIXER STOP TIME
SELECT A KEY

20. Pressing any of the *Dispense* keys will cause the *Dispense* LED(s) of the corresponding Hopper to blink and the LCD/VFD screen will display the **Mixer Stop Time** for the indicated Hopper as follows:

MIXER STOP TIME
SEC.

21. If the *Stop* key is pressed the LCD/VFD screen will display the following:

FILL CONSTANT
OZ./SEC.

22. If the *Stop* key is pressed the LCD/VFD screen will display one of the following:

RINSE TIME
SEC.

23. If the *Stop* key is pressed the LCD/VFD screen will display one of the following:

24. If the ▼ and ▲ keys are pressed the Rinse Lockout will toggle between "on" and "off".

RINSE WARNING ON	RINSE WARNING OFF
---------------------	----------------------

25. If the *Stop* key is pressed the LCD/VFD screen will display one of the following:

26. If the ▼ and ▲ keys are pressed the Rinse Warning will toggle between "on" and "off".

RINSE LOCKOUT ON	RINSE LOCKOUT OFF
---------------------	----------------------

27. If the *Stop* key is pressed the LCD/VFD screen will display the following:

RINSE LOCKOUT
HRS.

28. If the *Stop* key is pressed the LCD/VFD screen will display the following:

WATER TEMP.
DEG F

29. If the *Stop* key is pressed the LCD/VFD screen will display the following:

TEMP LOCKOUT ON	TEMP LOCKOUT Off
--------------------	---------------------

30. If the ▼ and ▲ keys are pressed Low Temperature Lockout will toggle between "on" and "off".

31. If the *Stop* key is pressed the LCD/VFD screen will display the following:

LOW TEMP LOCKOUT
DEG F

32. If the *Stop* key is pressed the LCD/VFD screen will display the following:

HOPPER STATUS
SELECT A KEY

33. Pressing any of the *Dispense* keys will cause the *Dispense* LED(s) of the corresponding Hopper to blink and the LCD/VFD screen will display the status for the indicated Hopper as follows:

HOPPER STATUS ON	HOPPER STATUS Off
---------------------	----------------------

34. If the ▼ and ▲ keys are pressed the hopper status will toggle between "on" and "off".

35. If the *Stop* key is pressed the LCD/VFD screen will display the following:

AUGER STATUS
SELECT A KEY

36. Pressing any of the *Dispense* keys will cause the *Dispense* LED(s) of the corresponding Hopper to blink and the LCD/VFD screen will display the status for the indicated Auger as follows:

AUGER STATUS ON	AUGER STATUS Off
--------------------	---------------------

37. If the ▼ and ▲ keys are pressed the Auger Status will toggle between "on" and "off".

38. If the *Stop* key is pressed the LCD/VFD screen will display the following:

MIX/DUMP STATUS
SELECT A KEY

39. Pressing any of the *Dispense* keys will cause the *Dispense* LED(s) of the corresponding hopper to blink and the LCD/VFD screen will display the status for the indicated Mixer/Dump Valve as follows:

MIX/DUMP STATUS ON	MIX/DUMP STATUS Off
-----------------------	------------------------

40. If the ▼ and ▲ keys are pressed the Mixer/Dump Valve Status will toggle between "on" and "off".

41. If the *Stop* key is pressed the LCD/VFD screen will display one of the following:

DISPLAYED UNITS ENGLISH	DISPLAYED UNITS METRIC
----------------------------	---------------------------

42. If the ▼ and ▲ keys are pressed the Displayed Units will toggle between "English" and "Metric".

43. If the *Stop* key is pressed the LCD/VFD screen will display the following:

RESET SYSTEM
ARE YOU SURE?

44. Pressing the ▼ and ▲ keys simultaneously will cause all parameters to revert to default values and the menu to display the following:

RESET SYSTEM
COMPLETED

DEFINITION OF SCREENS DURING NORMAL OPERATION:

- | | |
|--|--------------------------------------|
| <p>1. Initialization Screen
 Definition – This screen is displayed only during the first few seconds after “power-on”. The only purpose of this screen is to display the System Software Title (DISPENSER) and Version Number (V #.##).</p> | <p>RESET SYSTEM COMPLETED</p> |
| <p>2. Low Water Level Screen
 Definition – This screen is displayed after the Initialization Screen during the initial filling of the water tank (<i>first fill</i>). Once the water in the reservoir tank has reached the appropriate fill level this screen is retired.</p> | <p>PLEASE WAITLOW WATER LEVEL</p> |
| <p>3. Low Temperature Lockout Screen
 Definition – This screen is displayed when the Low Temperature Lockout feature is ON and the present water temperature is below the Low Temperature Lockout trip point.</p> | <p>PLEASE WAITLOW WATER TEMP.</p> |
| <p>4. System Rinse Lockout Screen
 Definition – This screen is displayed when the Rinse Lockout feature is ON and all Hoppers have met the conditions for Rinse Lockout. A Hopper will enter Rinse Lockout when the respective Hopper has dispensed but has not been rinsed for a period of time greater than that defined by the Rinse Lockout Time. Since the system has no method of recording elapsed time during “power-off”, the system will place all Hoppers in Rinse Lockout upon “power-on” as a sanitary precaution.</p> | <p>PLEASE RINSE TO CONTINUE</p> |
| <p>5. Rinse Screen
 Definition – This screen appears when the Rinse Key is pressed while the system is waiting to dispense. If any of the Dispense Keys are pressed while this screen is being displayed the system will rinse the Hopper corresponding to the depressed key. If the Rinse Key is released while a Hopper is being rinsed this screen will remain until the rinse process is complete.</p> | <p>PRESS AND RELEASE TO RINSE</p> |
| <p>6. Selection Screen
 Definition – This screen is displayed along with a Dispense Screen while the system is waiting to dispense. This screen alternates with a Dispense Screen every three seconds.</p> | <p>PLEASE SELECT CHOICE OF DRINK</p> |
| <p>7. Portion Control Dispense Screen
 Definition – This screen is displayed while the system is waiting to dispense if the Dispense Mode is set to Portion Control. This screen alternates with the Selection Screen every three seconds.</p> | <p>PRESS AND RELEASE TO DISPENSE</p> |
| <p>8. Free Flow Dispense Screen
 Definition – This screen is displayed while the system is waiting to dispense if the Dispense Mode is set to Free Flow. This screen alternates with the Selection Screen every three seconds.</p> | <p>PRESS AND HOLD UNTIL 2/3 FULL</p> |
| <p>9. Rinse Warning Screen
 Definition – This screen appears when the Rinse Warning feature is ON and a Hopper (identified by @) has dispensed but has not been rinsed for a period of time greater than that defined by (50 * Rinse Lockout Time) minutes. For example: if the Rinse Lockout Time is 6 Hrs and the Rinse Warning feature is ON then the Rinse Warning will be triggered when a Hopper is not rinsed for 300 minutes (5 hours). Triggering a Rinse Warning will cause the audible alarm to sound for two seconds and the Rinse Warning Screen to be displayed for five seconds. The system will then revert back to normal operation. If the offending Hopper is not rinsed after the first Rinse warning additional Rinse Warnings will be triggered every five minutes until the respective Hopper is rinsed.</p> | <p>HOPPER # @MUST BE RINSED</p> |
| <p>10. Rinse Lockout Screen
 Definition – This screen appears when a Dispense Key is pressed corresponding to a Hopper (identified by @) that has entered Rinse Lockout. A Hopper will enter Rinse Lockout when the respective Hopper has dispensed but has not been rinsed for a period of time greater than that defined by the Rinse Lockout Time. Once a Hopper enters Rinse Lockout the LED's of the Dispense Keys related to that Hopper will turn OFF thus indicating that the Hopper will no longer dispense.</p> | <p>HOPPER #@ MUST BE RINSED</p> |
| <p>11. High Temperature Lockout Screen
 Definition – This screen is displayed when the present water temperature is 10 °F above the water temperature set point.</p> | <p>PLEASE WAIT HIGH WATER TEMP</p> |
| <p>12. Hopper Status Warning Screen
 Definition – This screen appears when a Dispense Key is pressed corresponding to a Hopper (identified by @) that has been turned OFF. Once a Hopper has been turned OFF the LED's of the Dispense Keys related to that Hopper will turn OFF thus indicating that the Hopper will no longer dispense.</p> | <p>HOPPER # @ IS OFF</p> |

DEFINITION OF ERROR SCREENS AND TROUBLESHOOTING

IF ANY OF THESE ERROR SCREENS COME UP ALSO CHECK THE SAFETY RELAY IN ADDITION TO THE COMPONENT IN QUESTION. SEE RELAY TEST.

1. Over Temperature Error Screen

Definition – This screen is displayed and the system is shut down when the present water temperature is sensed higher than 208 °F.

Possible Causes: Invalid required Water Temperature or Faulty Water Temperature Sensor.

SYSTEM ERROR!
OVER TEMPERATURE

2. Water OverflowError Screen

Definition – This screen is displayed and the system is shut down when the OT/OF Sensor is detecting a rapid change in ambient temperature inside the overflow tube.

Possible Causes: Faulty fill Solenoid or faulty/ disconnected Level Sensor.

!SYSTEM ERROR!
WATER OVERFLOW

3. No Fill Response Error Screen Definition – This screen is displayed and the system is shut down when the Fill Solenoid has been continuously energized (open & filling) for more than five minutes during the first fill or more than 30 seconds thereafter.

Possible Causes: Water supply is turned OFF or faulty / disconnected Level Sensor.

!SYSTEM ERROR!
NO FILL RESPONSE

4. No Temperature Response Error Screen

Definition – This screen is displayed and the system is shut down when the Water Heater has been continuously energized (heating) for more than 30 minutes .thereafter.

Possible Causes: faulty/disconnected Level Sensor, faulty Water Temperature Sensor, or faulty Water Heater.

!SYSTEM ERROR!
NO TEMP RESPONSE

5. Water Heater Error Screen

Definition – This screen is displayed and the system is shut down when the required status (ON/OFF) of the Water Heater does not match the sensed status for more than two seconds.

Possible Causes: faulty/disconnected Water Heater, faulty/disconnected Triac, or faulty/disconnected Safety Relay.

!SYSTEM ERROR!
WATER HEATER

6. Fill Solenoid Error Screen – Water Inlet Valve

Definition – This screen is displayed and the system is shut down when the required status (ON/OFF) of the Fill Solenoid does not match the sensed status for more than two seconds.

Possible Causes: Faulty/disconnected Fill Solenoid or faulty/disconnected Safety Relay.

!SYSTEM ERROR!
FILL SOLENOID

7. Auger Motor Error Screen

Definition – This screen is displayed and the **entire system is inoperable** when the required status (ON/OFF) of the Auger Motor (identified by @) does not match the sensed status for more than two seconds.

Possible Causes: Faulty/disconnected Auger Motor.

!SYSTEM ERROR!
AUGER MOTOR

8. Dump Solenoid Error Screen – Dispense Valve Error Screen

Definition – This screen is displayed and the **entire system is inoperable** when the required status (ON/OFF) of the Dump Solenoid (identified by @) does not match the sensed status for more than two seconds.

Possible Causes: Faulty/disconnected Dump Solenoid [Dispense Valve] or faulty/disconnected Safety Relay.

!SYSTEM ERROR!
DUMP MOTOR # @

9. Mixer Motor Error Screen

Definition – This screen is displayed and the **entire system is inoperable** when the required status

(ON/OFF) of the Mixer Motor (identified by @) does not match the sensed status for more than two seconds.

Possible Causes: Faulty/disconnected Mixer Motor or faulty/disconnected Safety Relay.

If Mixer Motor or Relay check out good, manually check for loose connections or defective parts on all 120V ac circuits including: fuse, fuse holder, transformer, hi-limit, and harness.

!SYSTEM ERROR!
MIXER MOTOR # @

Note: IF either the Auger Motor, or Mixer Motor, or Solenoid Error Screen appear: The entire system is inoperable this means that one of either the Auger Motor, or Mixer Motor, or Solenoid [Dispense Valve] is **not** functional while that Hopper Status is **ON**.
To continue operating the other Hoppers: Go into Program Mode [by pressing simultaneously the Rinse and Stop keys], Press RINSE to get the HOPPER STATUS screen, Press ▼ or ▲ key to set the non-functional HOPPER STATUS to OFF; Wait at least 10 sec., then Exit program. Reset Power Switch [OFF and ON].

10. High Temperature Lockout Screen

Definition – This screen is displayed when the present water temperature is 10 °F above the water temperature set point.

Possible Causes: Faulty/disconnected Temperature Sensor.

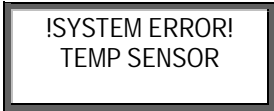

11. Over Temperature / Over Flow Error Screen

Definition – This screen is displayed and the system is shut down when the present water temperature is sensed higher than 208 °F.

Possible Causes: Faulty/disconnected Over-Temperature/Over-Flow Sensor.

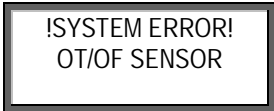

12. Communications Error Screen

Definition – This screen is displayed and the system is shut down when the Communications Link between the Display Board and the Control Board has been interrupted for more than five seconds and then re-established.

Possible Causes: Faulty connection between the Display Board and the Control Board.

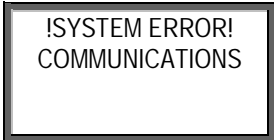

13. Communications Failure Screen

Definition – This screen is displayed and the system is shut down when the Communications Link between the Display Board and the Control Board has been interrupted for more than five seconds.

Possible Causes: Faulty connection between the Display Board and the Control Board.

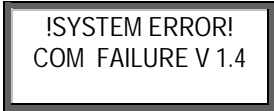

TESTS

1) Water Inlet Valve Test

Turn power off. If the water level rises inside the tank, the Water Inlet Valve is leaking. Disconnect wires from the Water Inlet Valve coil and connect a 2 wire line cord to the terminals. Plug it into a 115V outlet. If water flows in and stops when you pull it out, the Valve is working fine. Repeat this test a few times. The problem may be in the Probe. If the water does not flow in when the cord is plugged into an electrical outlet, the Solenoid coil may be damaged, opened or the valve may have an obstruction preventing the water from flowing in. Clean or replace it.

A Check Valve is installed to prevent backflow.

To check proper function of Check Valve, disconnect water line from the Check Valve, check for dripping from the disconnected end of the Check Valve. If it leaks replace it.

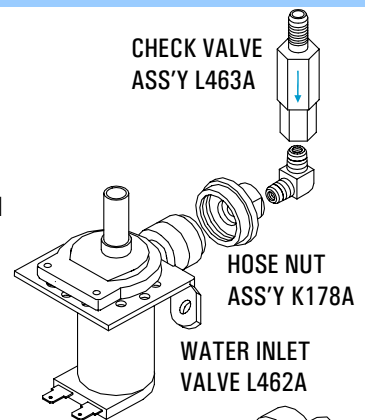

2) Water Level Probe Test

If there is a lack of water, you will get an error message on the LCD window. Check the probe as follows:

Turn on the power and water supply. Check inside the tank to make sure the water is not touching the Probe. Pull the wire and terminal out of the Probe rod. If water starts flowing into the tank, the Probe may be grounded, due to excessive liming. Check with Ohm meter. Clean or replace.

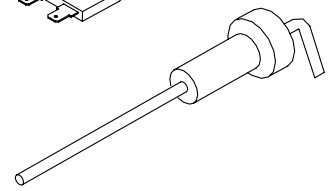

3) Relay Test

Turn Power Switch ON.

Measure Voltage across Output "COM" to Ground. Should read 120 V.

Measure Voltage across Input "NO" to Ground. Should read 120 V.

Measure Voltage across Input to Coil. Should read 24 VDC.

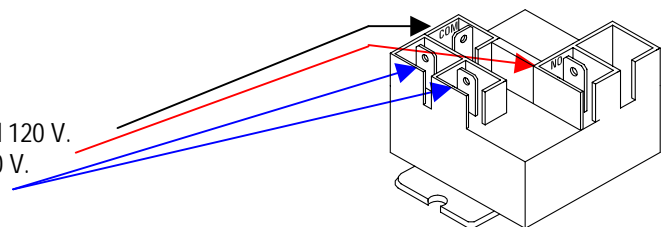

RECOMMENDED PREVENTIVE MAINTENANCE

1. CHECK ALL DISPENSE VALVES FOR LIME BUILD-UP.

- Drain The Water Tank To Just Below The Level Of The Dispense Valves.
- Remove The Valves And Clean. (You Can Take These Valves Apart By Hand As Shown).
- Replace The Assembly As Needed (L467A).
- Replace The Valve Into The Tank And Refill tank.

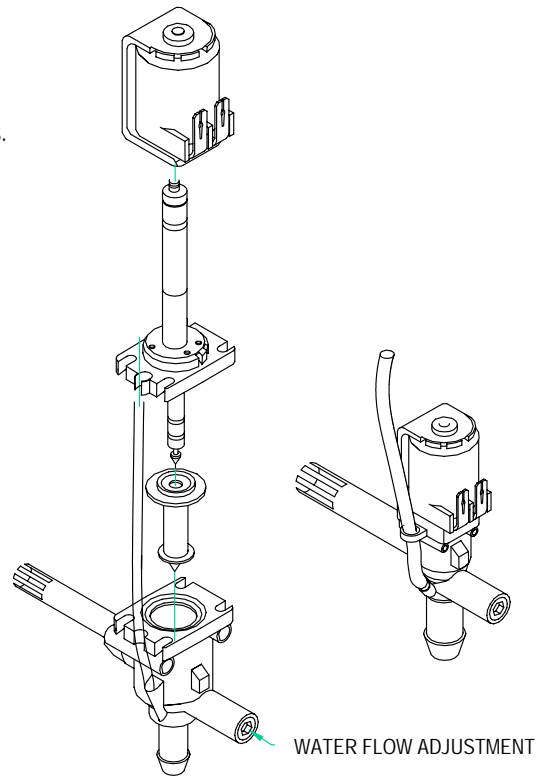

2. CHECK ALL CHAMBER MOUNTS FOR SIGNS OF WEAR

- A. Product running down the front of the unit.
- B. Product built up on the back of Chamber Mount.
 - Remove Chamber Mount.
 - Clean And Re-Lubricate motor shaft using food grade lubricant only
 - Replace with new Chamber Mount.

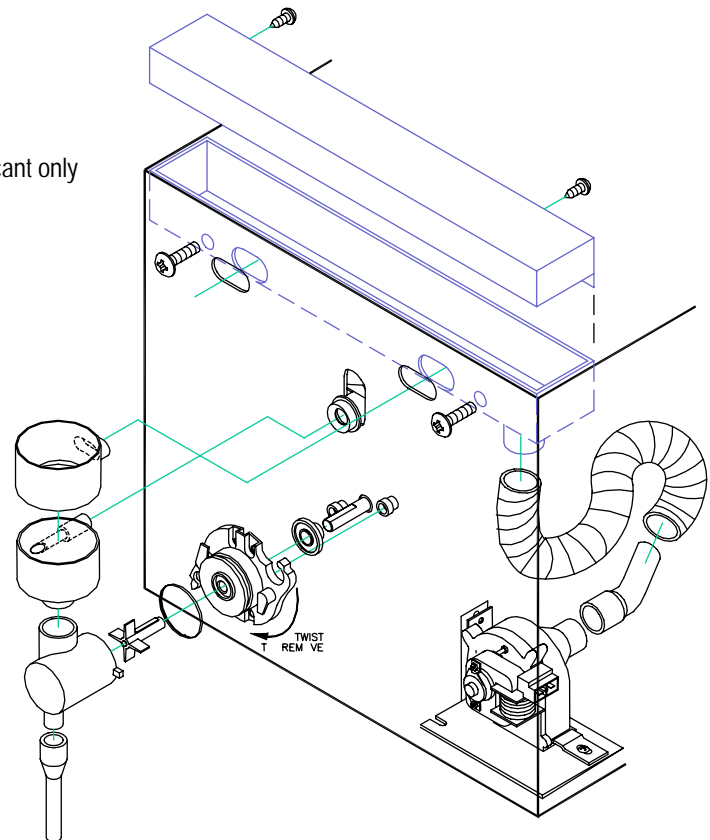

3. CLEAN OUT VENT MOTOR, TROUGH AND TUBING

- Remove Two Screws Holding Trough In Place.
- Clean, And Replace Trough.
- Remove Hose Assembly From The Motor.
- Clean Out And Replace.

To Replace The Picture / Duratran:

Lift up the two end tabs on top of door with a pointed object or flat head screwdriver.
Pull the entire picture frame out. Open up the two clear panels and replace picture.
Tuck clear plastic panel inside bracket at top.
Tuck clear plastic panel inside bracket at top.

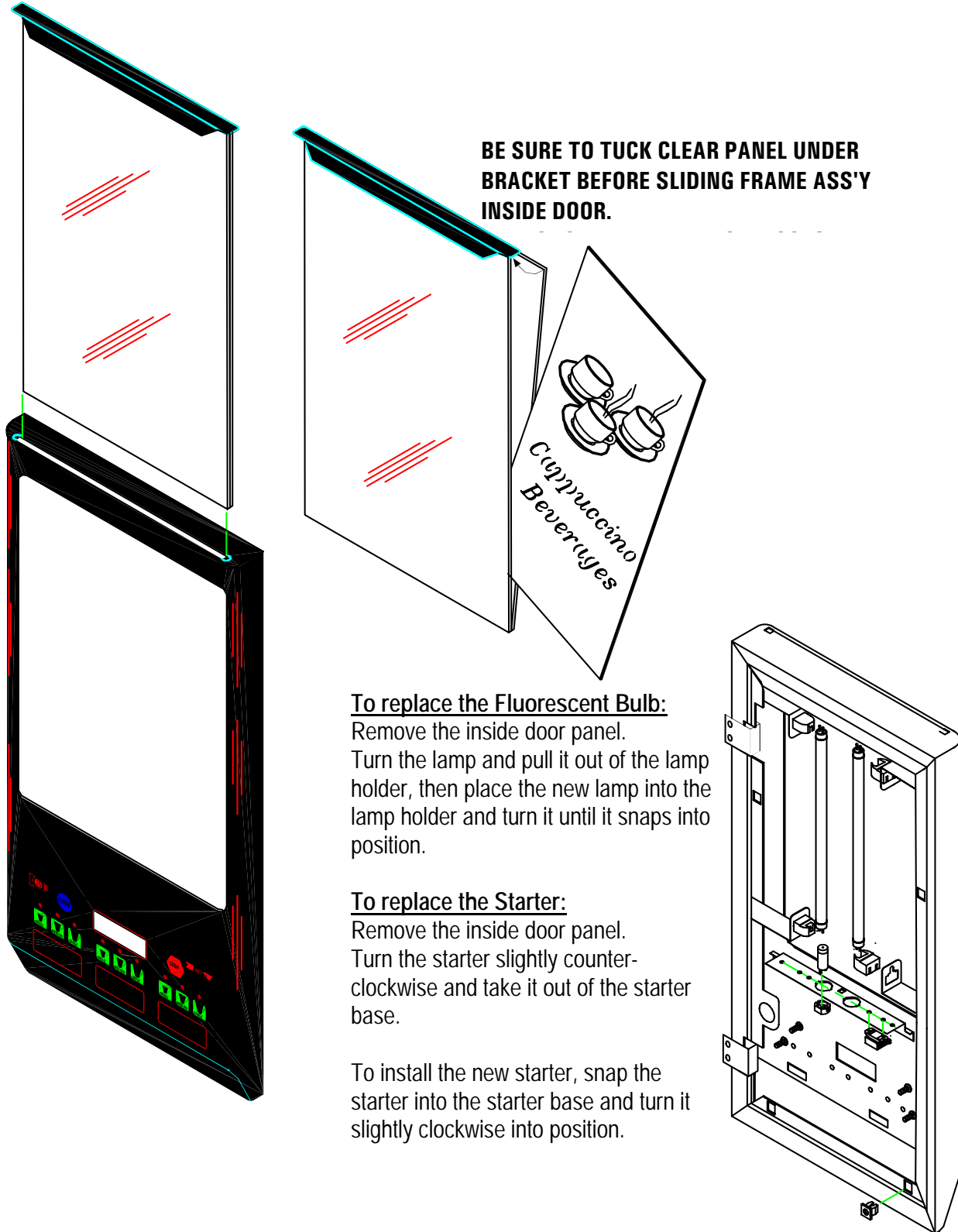

BE SURE TO TUCK CLEAR PANEL UNDER BRACKET BEFORE SLIDING FRAME ASS'Y INSIDE DOOR.

To replace the Fluorescent Bulb:

Remove the inside door panel.
Turn the lamp and pull it out of the lamp holder, then place the new lamp into the lamp holder and turn it until it snaps into position.

To replace the Starter:

Remove the inside door panel.
Turn the starter slightly counter-clockwise and take it out of the starter base.

To install the new starter, snap the starter into the starter base and turn it slightly clockwise into position.

SANITIZING, CLEANING AND REFILLING HOPPERS

Sanitizing: All food dispensing units should be sanitized periodically. All parts to be sanitized must be cleaned first.

To prepare a sanitizing solution: ADD 2 TSP. OF LIQUID CLOROX BLEACH (5.25% CONCENTRATION) TO 1 GALLON OF WATER AT ROOM TEMPERATURE (70°- 90°F).

Note: Always start with a unopened bottle of Clorox Bleach since the solution from an opened bottle has a short life span.

- Soak all parts for a minimum of 3 min. in the sanitizing solution.
- Let all sanitized parts drain and dry naturally. DO NOT WIPE THEM DRY.
- Before using the sanitized unit (or parts) with food stuffs, rinse all parts thoroughly with water.

Water pipe connecting and fixtures directly connected to a potable water supply shall be sized, installed, and maintained in accordance with Federal, State, and Local codes (section 7).

Cleaning

1. Turn the power switch to OFF.
2. Remove the drip tray with grill and empty the contents.
3. Wash and let dry the tray and grill (use a mild dishwasher detergent).
4. Wash and let dry the dispense area.
5. Turn the power switch to ON.

Cleaning the Hoppers (See Illustration E)

1. Open the cabinet door and raise the top cabinet lid.
2. Take the hopper out of the cabinet.
3. Pull off the elbow chute and remove the hopper cover.
4. Unscrew the auger gear CW while holding steady the auger inside the hopper. Take out the auger, agitator wheel, and spring.
5. Rinse each item thoroughly.
6. Let dry all items and reassemble.

Filling the Hoppers

1. Open the cabinet door, raise the top cabinet lid.
2. Fill each hopper with the correct product. **Note:** Hoppers can also be removed for filling.
3. Reposition hoppers in the hopper compartment, making sure the hoppers are properly seated.

Flushing the Whipper Chamber

1. Open the cabinet door and turn the RINSE switch to ON.
2. Place a container under each dispense nozzle and push the dispense switches.
Note: On manual dispense machines, push and hold the dispense buttons for 10 seconds.
3. Open the cabinet door and turn the Rinse switch back to OFF.
4. Wash and let dry the splash panel.
5. Remove the drip tray, wash and let dry thoroughly.

Removing and Cleaning the Whipper Chambers (See Illustration E)

1. Remove the dispense cap by pulling it forward and at the same time twisting it clockwise.
2. Grab and pull the mixing bowl out of the mixing bowl socket.
3. Grab and twist the whipping chamber clockwise and pull it off the mounting plate.
4. Pull the Whipper blade off the motor shaft. Notice the flat keyway on the shaft and the matching keyway inside the Whipper blade shaft.
It is important that these two keyways are lined up when re-assembling the components.
5. Twist the mounting plate clockwise and pull it off the motor shaft.
6. Slip off the o-ring from the Whipper chamber mounting plate and clean o-ring and o-ring seat.

Removing and Cleaning the Mixing Chambers (See Illustration E)

1. Remove the dispense cap.
2. Pull the mixing bowl out of the mixing bowl socket.
3. Take out the extension tubes.
4. Rinse them thoroughly

HOPPER and DISPENSING CHAMBER ASS'YS WITH WIRE AUGERS - ILL. E

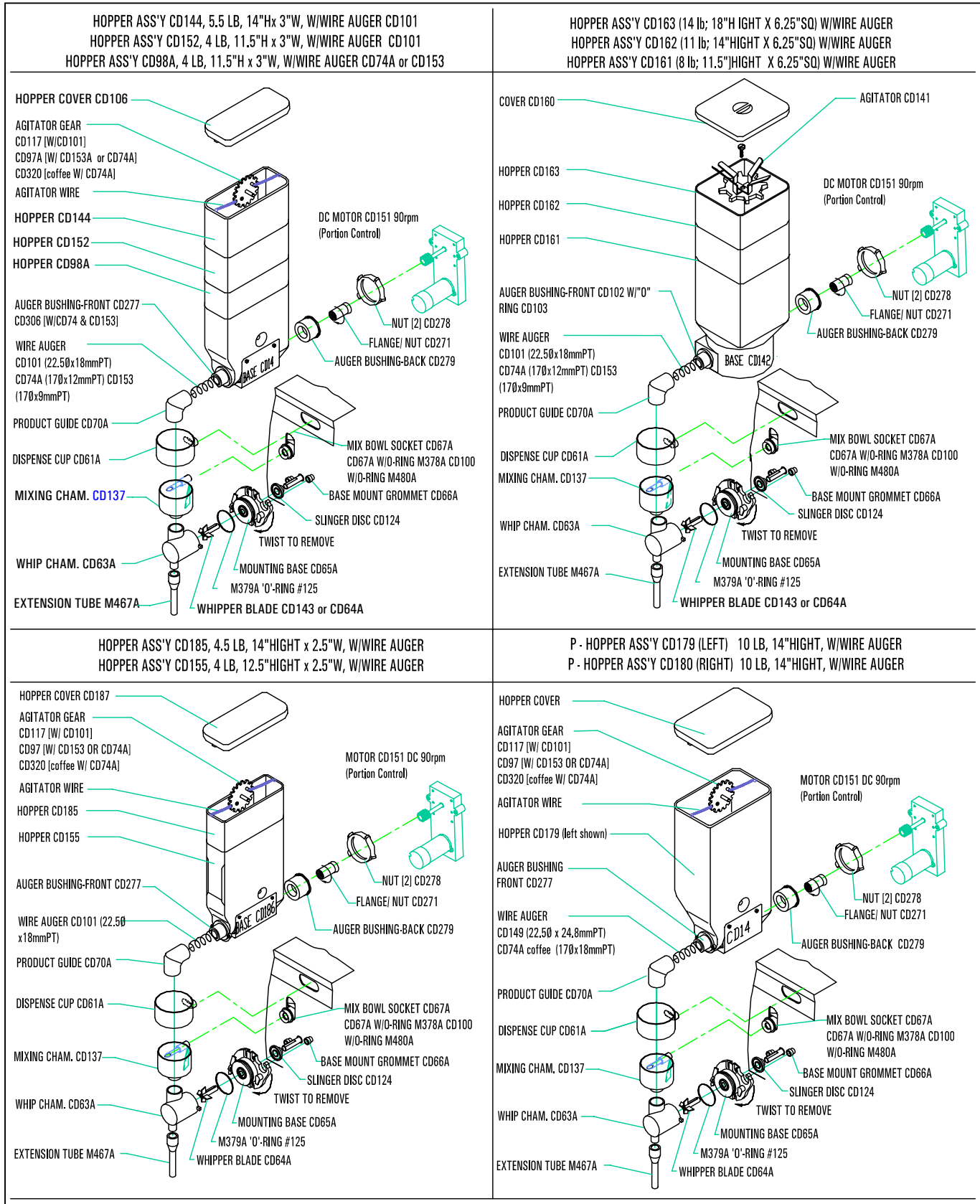

HOPPER and DISPENSING CHAMBER ASS'Y WITH NYLON AUGERS - ILL. E

HOPPER ASS'Y CD104, 7 LB, 18"HIGHT x 3"W, W/NYLON AUGER
 HOPPER ASS'Y CD120, 5.5 LB, 14"HIGHT x 3"W, W/NYLON AUGER
 HOPPER ASS'Y CD68A, 4 LB, 11.5"HIGHT x 3"W, W/NYLON AUGER
 HOPPER ASS'Y CD313, 1 LB COFFEE, 7.875" HIGHT x 3"W, W/NYLON AUGER

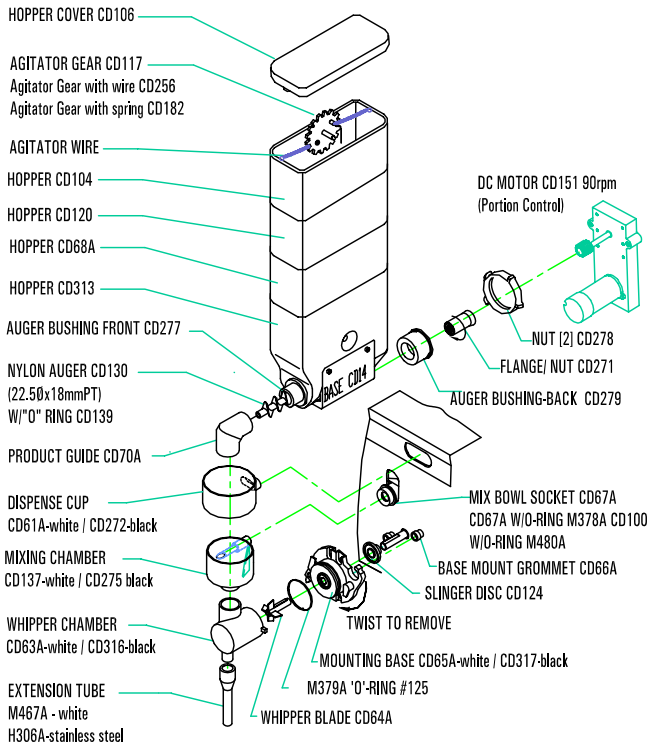

HOPPER ASS'Y CD105 (14 lb; 18" HIGHT X 6.25" SQ) W/NYLON AUGER
 HOPPER ASS'Y CD99A (8 lb; 11.5" HIGHT X 6.25" SQ) W/NYLON AUGER

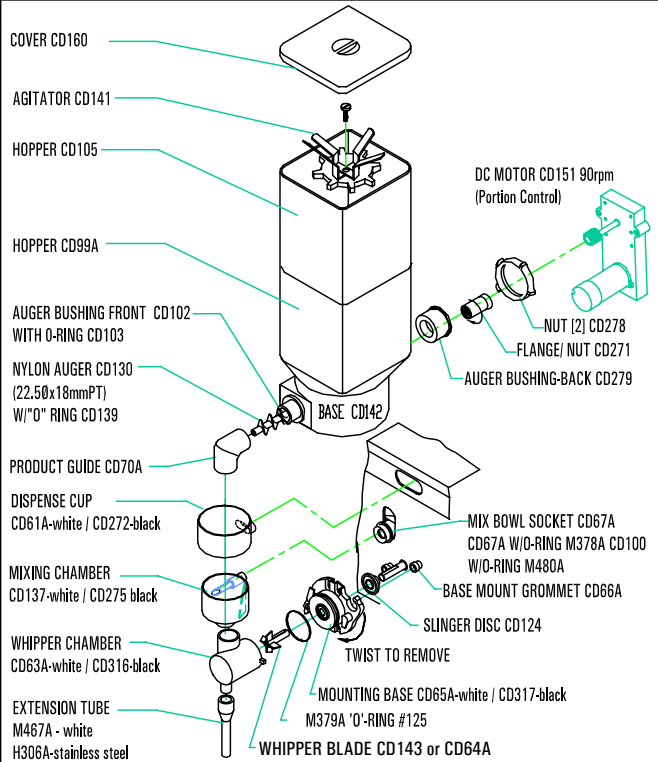

HOPPER ASS'Y CD338, 4.5 LB, 14"HIGHT x 2.5"W, W/NYLON AUGER
 HOPPER ASS'Y CD339, 4 LB, 12.5"HIGHT x 2.5"W, W/NYLON AUGER

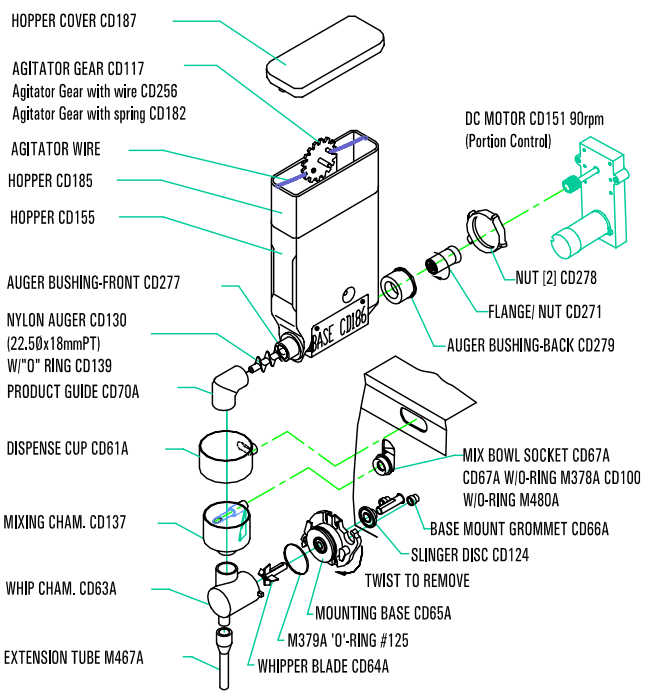

P - HOPPER ASS'Y CD308 LT & CD309 RT 10 LB, 14"H, W/NYLON AUGER
 P - HOPPER ASS'Y CD177 LT & CD178 RT 8 LB, 11.5"H, W/NYLON AUGER

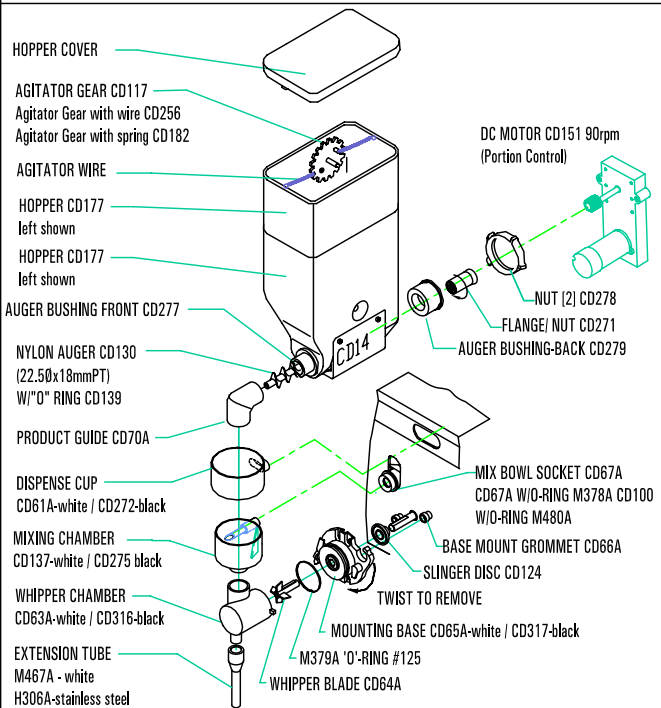

TROUBLESHOOTING GUIDE

WARNING: To reduce the risk of electrical shock unplug the dispenser power cord before repairing or replacing any internal components of the unit.. Before any attempt to replace a component be sure to check all electrical connections for proper contact

PROBLEM	PROBABLE CAUSE	REMEDY
1. Light Display not lit. No power.	a) Dispensing unit unplugged b) No power from Main Board or from Power Switch. c) Defective Bulb d) Loose Bulb in socket. e) Defective Ballast.	a) Reconnect dispensing unit b) Check for loose wire to Main Board or to Power Switch. c) Replace Bulb. d) Make sure bulb is seated properly in socket. e) Replace Ballast
2. No water when Rinse Switch is ON.	a) Water supply OFF. b) Clogged inlet screen (Water Inlet Valve). c) Inoperative Water Inlet Valve. d) Loose electrical connection.	a) Turn water ON. b) Disconnect water line and clean inlet screen. c) Check connection, if needed replace Valve. d) Check all electrical connections.
3. No product when Dispense Button is pressed	a) No product in Hopper. b) Auger not working. c) Damaged, loose, or missing Agitator Gear. d) Inoperative Auger Motor. e) Hopper outlet clogged f) Faulty Coupling.	a) Add product. b) Engage Hopper/Nut to Motor Gear (see Ill. E). c) Replace Agitator Gear (see Ill. E) . d) Check connections of Motor, if needed replace such components. e) Clean Hopper and check Cartridge Heater. f) Replace damaged Coupling components.
4. Water does not shut off. Water keeps dispensing.	a) Leaking Solenoid [Water Inlet Valve]. b) Inoperative Switches on Touch Pad. c) Inoperative Rinse Switch – Touch Pad d) Clogged/stuck Water Dispense Valve	a) Clean/check fittings of Valve. Replace Valve if needed. See “Water Inlet Valve Test” b) Check Touch Pad connections. Replace Touch Pad if needed. d) Clean/unclog Water Dispense (Dump) Valve. Replace Dispense Valve if inoperative.
5. No water is going into tank at all.	a) Water Inlet Valve malfunction. b) Probe malfunction.	a) Check Solenoid valve. Replace if necessary. See “Water Inlet Valve Test” b) Check Probe. Replace if necessary. See “Probe Test”.
6. Water will not stop flowing into tank.	a) Water Level Probe malfunction. b) Solenoid (Water Inlet Valve) malfunction.	a) Check Probe. Replace if necessary. See “Probe Test” b) Check Solenoid. Replace if necessary. See “Water Inlet Valve Test”
7. Water is not heating up in the water tank.	a) Temperature setting is incorrect. b) Loose connection to Heating element c) Heater is burned out or defective.	a) Set Temperature at 195°F – See Programming Instructions b) Make sure all wires are tight. c) Replace the Heater.
9. Water drips from mixing chamber	a) Leaking Water Dispense Valve b) Too much water in tank. c) Mixing Chamber clogged. d) Water Valve blocked by scales.	a) Replace Water Dispense (Dump) Valve b) Dispense some water from tank. c) Clean Mixing Chamber. d) Replace or clean Valve seat.
10. Cold drink.	a) Run out of hot water b) Temperature setting is incorrect. c) Loose electrical connection. d) Bad Heating Element or Heater is burned out.	a) Allow time for water in tank to heat after filling. b) Set temperature at 195°F. (See Programming Instructions) c) Check all electrical connections for contact. d) Replace Heater. (see Item 11 on Tank Ass’y ILL. F).
11. Drink too strong.	a) Water flow too low b) Product throw too high	a) Adjust water flow rate (see Ill. B) b) Adjust Gram Throw. (see Programming Instructions)
12. Drink too weak.	a) No product in hopper b) Product throw too low c) Water flow too high	a) Add product b) Adjust Gram Throw (see Programming Instructions) c) Adjust water flow rate (see Ill. B)
13. Drink not whipped.	a) Whipper Blade missing. b) Loose electrical connection to motor. c) Whipper Motor defective.	a) Replace Whipper Blade b) Check electrical connections to motor. c) Replace Whipper Motor.
14. Dispenser repeats cycle	a) Touch Pad defective. b) Power [Dispense] Relay stuck.	a) Replace Touch Pad. b) Replace Relay.

15. Noise coming from mixing chamber	a) Whipper blade not properly aligned or missing.	a) Check blade alignment, if needed replace blade and mixing chamber.
16. Grinding noise coming from unit	a) Hopper not properly engaged in back, or Hopper not seated properly	a) Check the mating between the auger motor's gear and hopper's coupling/nut. Check also pin in base. Pin must be dropped into hole in base.
17. Banging or clicking noise coming from hoppers	a) One or more Hoppers are empty or almost empty.	a) Fill Hoppers with product.

TANK ASS'Y - ILL. F

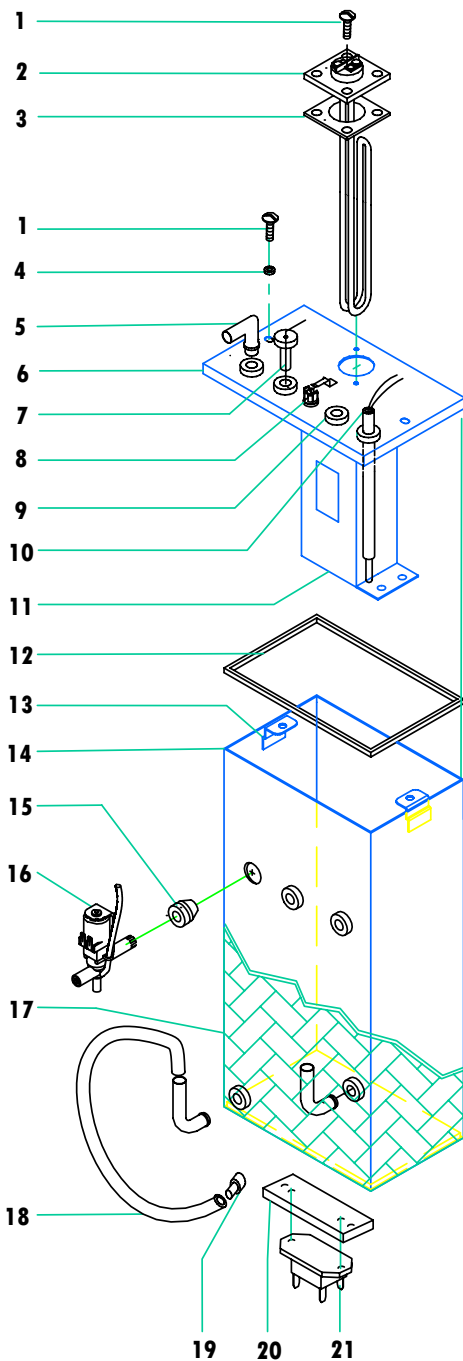

ITEM	DESCRIPTION	P/N	QTY
1	SCREW, S.S., 1/4 - 20 x 5/8	P465A	3
2	HEATER, 120V 1700W HEATER, 240V, 3000W	G267A G266A	1
3	GASKET, TANK HEATER	M502A	1
4	RUBBER GASKET, FOR SCREW (ITEM 1 P446A)	M533A	2
5	TUBE	K525A	1
6	TANK TOP	RY98A	1
7	WATER LEVEL PROBE [K402A + P410A]	K402Q	1
8	HI-LIMIT [TEMP.]	L573A	1
9	GROMMET PLUG (.466 ID) F/TESTING TEMP.	M494A	1
10	THERMISTOR PROBE [L616A-PROBE, L617A-SILICONE TUBE]	L639Q	1
11	HEATER DUCT HOUSING	RJ82A	1
12	SILICONE BUTT SPLICED GASKET [GB2MD] SILICONE BUTT SPLICED GASKET (GB3MD) SILICONE BUTT SPLICED GASKET [GB4MD] SILICONE BUTT SPLICED GASKET (GB5MD)	M498A M499A M500A M473A	1
13	TANK COVER BRACKETS	RI42A	2
14	TANK BODY	RI38A	1
15	GROMMET (.466 ID)	M461A	9*
16	DISPENSE VALVE (DUMP)	L467A	3*
17	TANK INSULATION MATERIAL	M183A	1
18	DRAIN HOSE (on a roll)	M483A	1
19	SILICONE DRAIN PLUG	M391A	1
20	COPPER PLATE- HEAT SINK FOR TRIAC WINGED NUT for mounting plate to tank	K770A P301A	1 2
21	TRIAC 35 AMP SCREW for Triac	L623A P182A	1 2

* Quantity shown is for GB3M5.5 IT. Quantities vary for each unit.

DOOR ASS'Y WITH COMPONENTS (GB3M5.5 IT SHOWN) ILL. G

ITEM	DESCRIPTION	GB1/2M5.5-IT	GB3M-5.5-IT	GB3M-10-IT	GB4M / 5M-IT
1	CLEAR WINDOW PANEL [1/8"]	M774A	M673A	M673A	M703A
2	PICTURE / DURATRAN FRAME ASS'Y	SB98Q	RX48Q	RX48Q	RZ91A
3	DOOR ASSEMBLY - RIGHT HINGED DOOR / LEFT HINGED DOOR	SN04Q	RX42Q	RY89Q / RY91Q	SA16Q / RZ90Q
4	TOUCH PAD [OR NG27A F/SMALL, MEDIUM, LARGE - OPTIONAL F/ GB3]	NG77A / NG78A	NG29A	NG29A	NG72A / NG74A
5	INSIDE DOOR PANEL	SD14A	RY95A	RY96A	SA17A / RZ89A

ITEM	DESCRIPTION	P/N	QTY
6	PROGRAMMING INSTRUCTIONS	NH06A	1
7	CLEANING INSTRUCTIONS	N978A	1
8	BACK PLATE FOR DOOR LATCH	SD08A	1
9	DOOR LATCH, HIDDEN (SET OF 2 UPPER AND LOWER)	M704A	1
10	SCREW, 8-32x1/2 FOR DOOR LATCH	P	2
11	SQ. NYLON RECEPTACLE	M08A	6
	SCREW F/ NYLON RECEPTACLE	P415A	6
12	BALLAST	CE221	2
13	STARTER BASE	B128A	2
14	STARTER, TYPE FS - 5, 5-6-8 WATT	L396A	2
15	DISPLAY BOARD WITH LCD WINDOW PIGGYBACK	L628A	1
16	NYLON SPACER, .563"L, WHITE, FOR BOARD ASS'Y	M735A	2
17	NYLON NUT, WHITE, FOR BOARD ASS'Y	P521A	4
18	STUD 10-32 x 1"	O5052	2
19	LAMP HOLDER	CE220	4
20	BULB, TYPE F8T5/CW [QTY FOR GB 1 & 2 IS "1"]	CE76A	2
21	DOOR HINGE [HIDDEN] [1 SET OF 2, UPPER & LOWER]	K618A	1
	DOOR HARNESS [+ DOOR CABLE CH16A]	CH18A	1

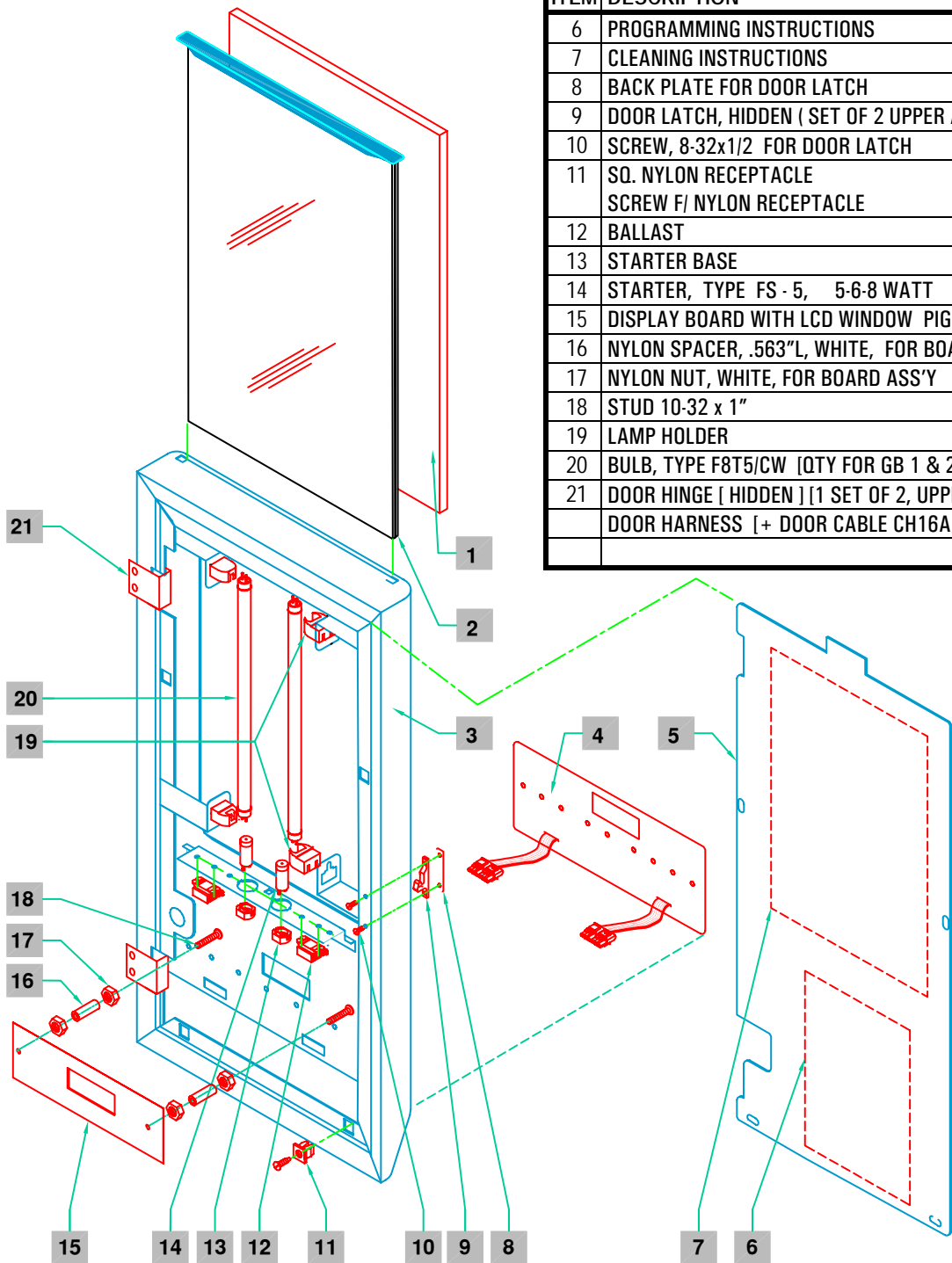

DESCRIPTION AND LOCATION OF COMPONENTS (GB3M5.5 IT SHOWN) ILL. H

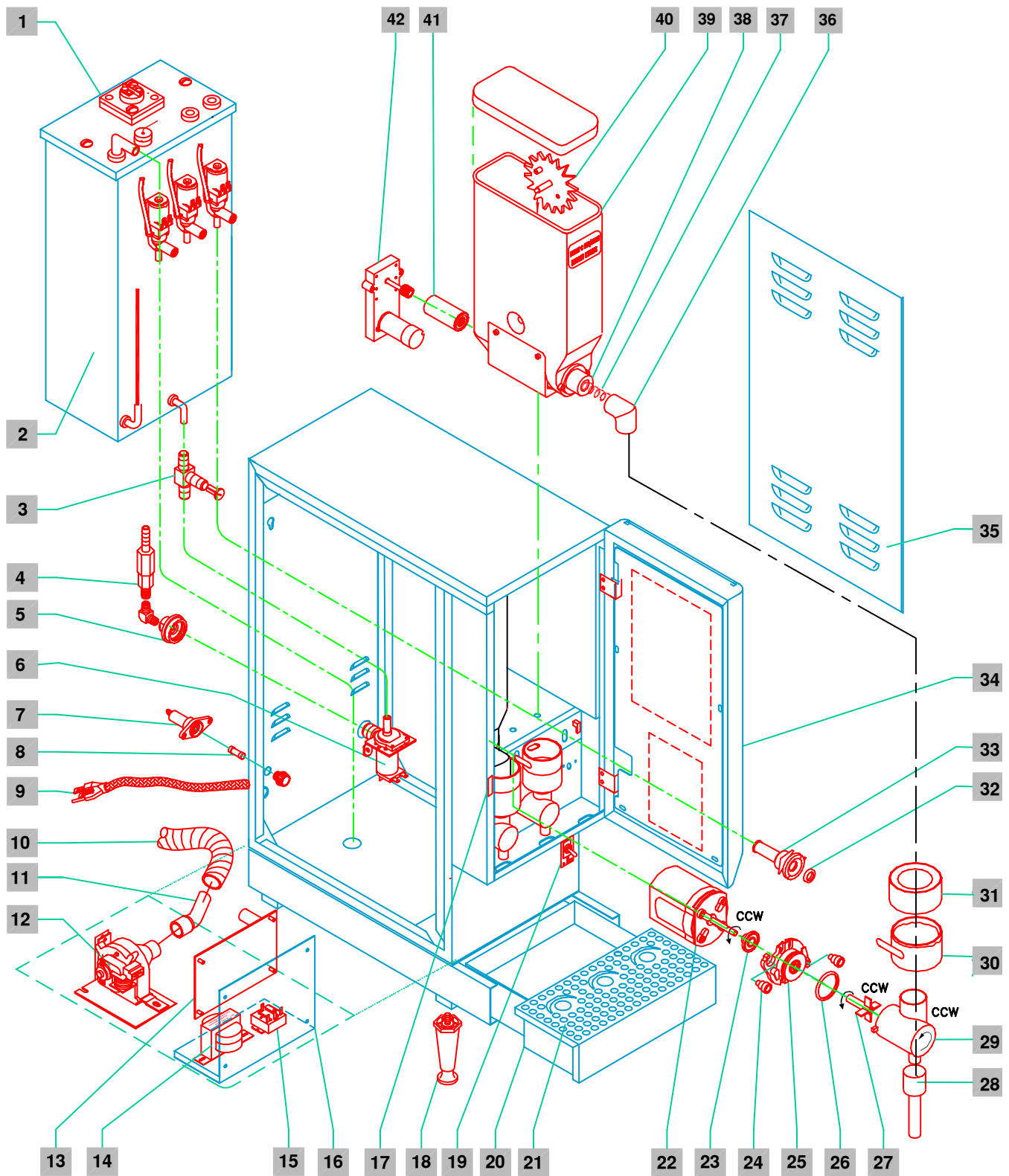

GBM-5.5-IT COMMON PARTS IDENTIFICATION LIST

ITEM	DESCRIPTION	GB1/2M5.5-IT	GB3M-5.5-IT	GB3M-10-IT	GB4/5M-IT
1	TANK TOP ASS'Y -- FOR DETAILS SEE ILL.F	SC32A	RY98Q	RY98Q	RJ86Q
2	TANK WELDMENT ASS'Y - FOR DETAILS SEE ILL.F	RJ83Q	RI38Q	RI38Q	RJ85Q
3	THERMISTER ASS'Y [FOR HI-TEMP. & WATER OVERFLOW]	L700Q	L700Q	L700Q	L700Q
4	CHECK VALVE [PREVENTS BACKFLOW]	L463A	L463A	L463A	L463A
5	HOSE NUT ASS'Y	K178A	K178A	K178A	K178A
6	WATER INLET VALVE	L462A	L462A	L462A	L462A
7	FUSE HOLDER (120/240V only)	C396A	C396A	C396A	C396A
8	FUSE BUSSMAN SC15 (120/240V) or CE187 STEPDOWN TRANSFORMER	CE181 /	CE181 /	CE181	CE181
9	POWER CORD	C032A	C032A	C032A	C032A
10	DUCT HOSE [FAN EXHAUST] (16" X 1" ø)	CD214	CD214	CD214	CD214
11	ELBOW INSERT [USE W/ FAN CD56A ONLY]	CD108	CD108	CD108	-
12	FAN [GB1,2,3 CD56A] [GB4,5 CD224 110-115V, 60HZ, 110cu.m./hr., AC]	CD56A	CD56A	CD56A	CD224
13	MAIN CONTROL BOARD	L627A	L627A	L627A	L627A
14	TRANSFORMER C-CLASS [use w/DC motor CD151]	CH332	CH332	CH332	CH332
15	RELAY, SAFETY	B190A	B190A	B190A	B190A
16	FLOOR BRACKET, [F/ MAIN CONTROL BOARD, TRANSFORMER, & RELAY]	RY69A	RY69A	RY69A	SA57A
17	DOOR LATCH HIDDEN	M705A	M705A	M705A	M705A
18	4" LEGS M172A OR 1" FEET M042A (SET OF 4)	M172A	M172A	M172A	M172A
19	POWER SWITCH (120 V) OR [120/240 V USE L299A]	L069A	L069A	L069A	L069A
20	DRIP TRAY PAN	RT61A / RI11A	RT62A	R004A	RH05A / RJ53A
21	DRIP TRAY GRILL	RI23A / RI18A	RT69A	R007A	RI20A / RJ56A
22	WHIPPER MOTOR short shaft [CD350]	CD75A	CD75A	CD75A	CD75A
23	SLINGER DISC	CD124	CD124	CD124	CD124
24	GROMMET CHAMBER MOUNTING	CD66A	CD66A	CD66A	CD66A
25	CHAMBER MOUNT [USE BAR FOR COFFEE]	CD65A	CD65A	CD65A	CD65A
26	"O" RING # 125 (used w/ grommet CD66A) [FOR CHAMBER MOUNT]	M379A	M379A	M379A	M379A
27	WHIP BLADE - WITH STRAIGHT PROPELLERS OR [CD143 W/ BEV. PROP.]	CD64A	CD64A	CD64A	CD64A
28	EXTENSION TUBE - PLASTIC OR [STAINLESS STEEL H306A]	M467A	M467A	M467A	M467A
29	WHIP CHAMBER	CD63A	CD63A	CD63A	CD63A
30	MIXING CHAMBER W/TRIANGLE WING [ALTERNATE CD62A W/ RECT WING]	CD137	CD137	CD137	CD137
31	DISPENSE CAP OR SPLASH GUARD	CD61A	CD61A	CD61A	CD61A
32	"O" RING (#110) (used w/socket CD67A)	M378A	M378	M378A	M378A
33	MIXING BOWL SOCKET (was CD100 W/O RING M480)	CD67A	CD67A	CD67A	CD67A
34	DOOR ASS'Y - [RIGHT / LEFT for GB3M-10] FOR DETAILS SEE ILL. G	SN04Q	RX42Q	RY89Q / RY91Q	SA16Q / SE45Q
35	SIDE PANELS	RG48A	RG48A	RG48A	RG48A
36	PRODUCT GUIDE	CD70A	CD70A	CD70A	CD70A
37	AUGER NYLON CD130 [22.5mmø X 18mm PT] [FOR CAPPUCCINO] OR AUGER WIRE CD101 [22.5mmø X 18mm PT] [FOR SOUP]	CD130 CD101	CD130 CD101	CD130 CD101	CD130 CD101
38	AUGER BUSHING, FRONT [STD] W/"O" RING CD103	CD102	CD102	CD102	CD102
39	CANISTER ASS'Y WITH COVER [w/NYLON auger] OR [CD144 w/WIRE auger]	CD120	CD120	CD120	CD120
40	AGITATOR (GEAR) [CD182 - OPTINAL]	CD117	CD117	CD117	CD117
41	FLANGE (NUT) [CD340 - OPTIONAL]	CD136	CD136	CD136	CD136
42	DC AUGER MOTOR 90 RPM CD151 [W/SCREW P443A]	CD151	CD151	CD151	CD151

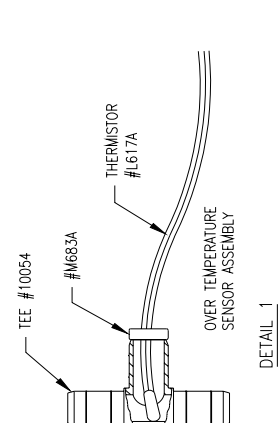
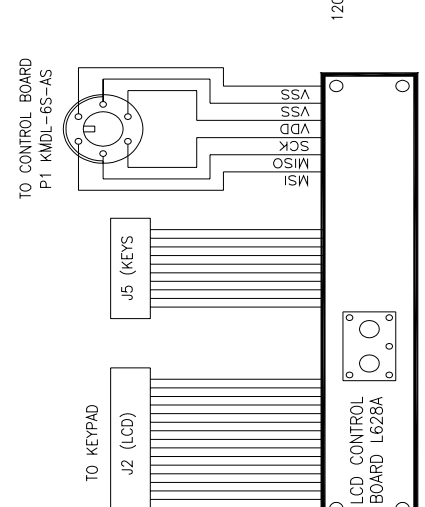
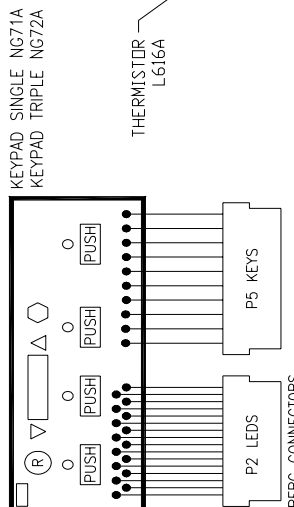
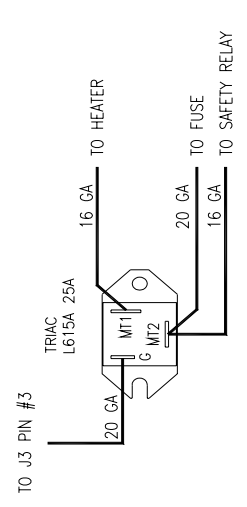
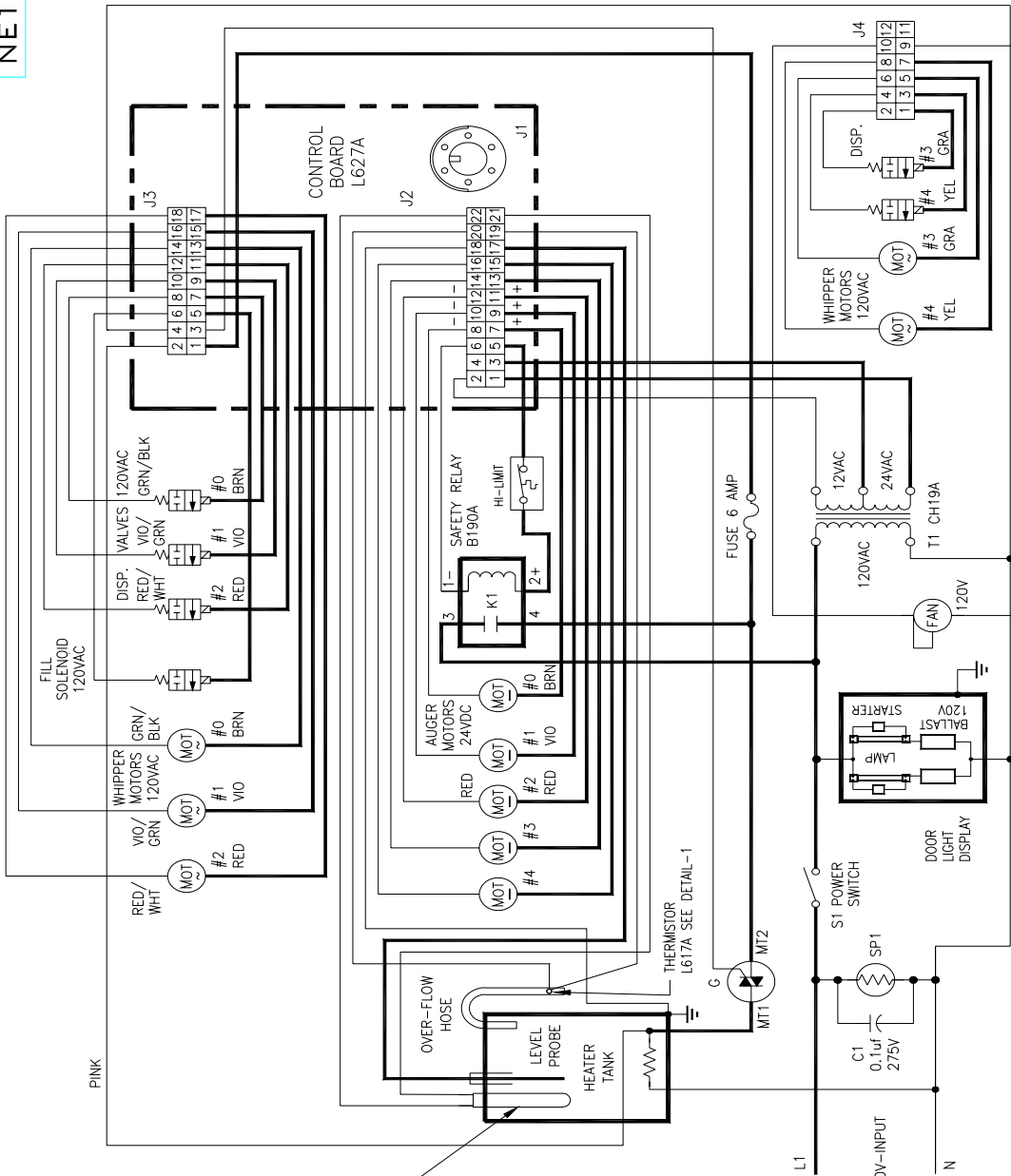

REV	BY	DATE	DESCRIPTION
G	MM	5/17/92	ADDED WIRE COLORS
F	MM	5/12/92	REDESIGNED
E	MM	7/7/2000	ADDED C1 & SP1
D	MM	12/9/99	MOTOR NUMBERS CHANGED TO MEET PINOUT
C	MM	8/23/99	ADDED COLOR CODE

TOLERANCES UNLESS OTHERWISE SPECIFIED	FINISHED DIMENSIONS	DECIMAL	FRACTIONAL	MATERIAL	ANGULAR
	✓	±0.005	±1/64		

DO NOT SCALE THIS DRAWING	DRAWN BY	MM <th>DATE</th> <th>5/6/99</th> <th>SCALE</th> <th>1 : 1</th> <th>PART NO</th> <th>NE108</th>	DATE	5/6/99	SCALE	1 : 1	PART NO	NE108
---------------------------	----------	--	------	--------	-------	-------	---------	-------

120V

Cecilware Corporation 43-05 20 AVE. L.I.C. NY 11105
 TITLE ELECTRICAL DIAGRAM - 120V (GB5MD-IT) DRAWING NO NE108 REV. G

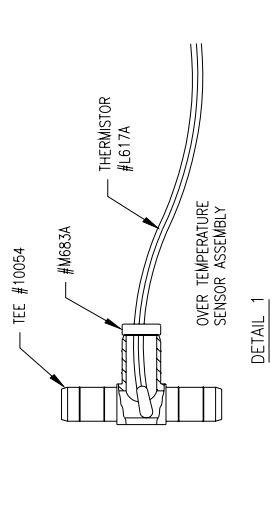
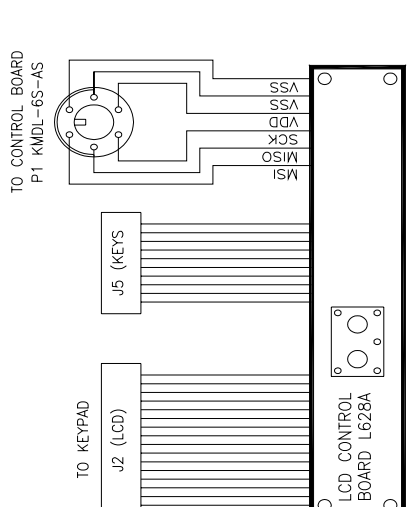
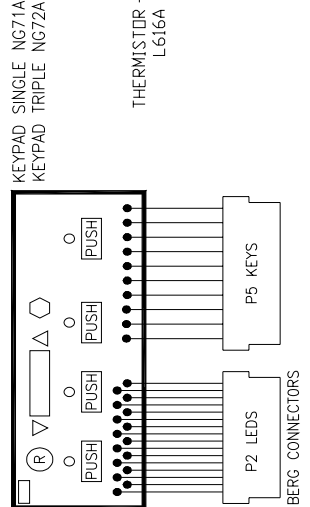
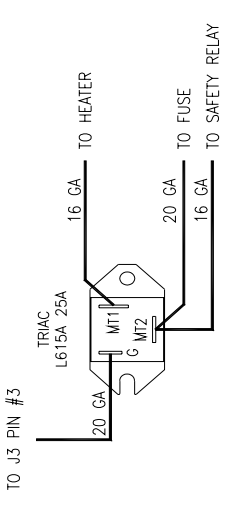
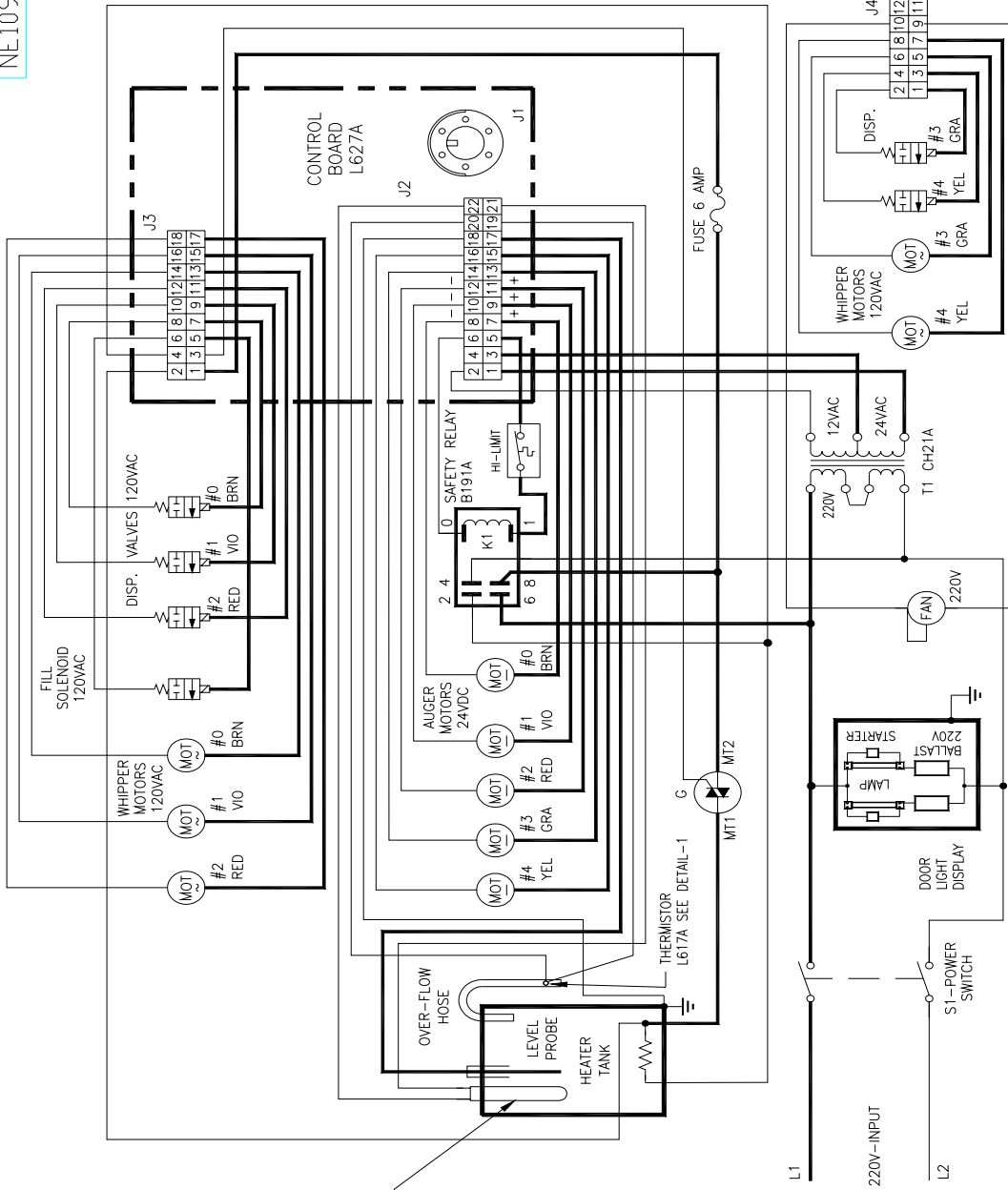

REV.	BY	DATE	DESCRIPTION
D	M.K.	5/4/02	REDESIGNED
C	M.K.	12/9/99	CHANGED MOTOR NUMBERS TO MEET PINOUT & ADDED COLOR CODE
B	M.K.	7/6/99	ADDED HI-LIMIT SWITCH
A	M.K.	5/24/99	REMOVED POSITIONS 19-22 FROM I3

TOLERANCES UNLESS OTHERWISE SPECIFIED	FINISHED DIMENSIONS	DECIMAL	FRACTIONAL	ANGULAR	MATERIAL
		±.005	±1/64	±1/2°	

DO NOT SCALE THIS DRAWING	SCALE	DATE	DATE	APPROVED BY	DATE	DATE	DATE	DATE	DATE	DATE	DATE
	1 : 1										

220V

DETAIL 1

TITLE ELECTRICAL DIAGRAM - 220V 3KW (GB5MD-IT)
 PART NO. NE109
 DRAWING NO. NE109
 48-05 20 AVE. L.I.C. NY 11105
 REV. D

NE110

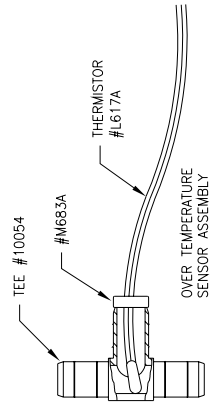
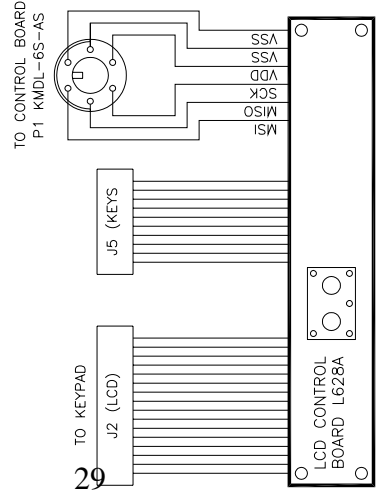
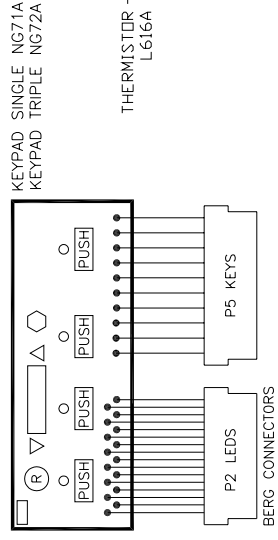
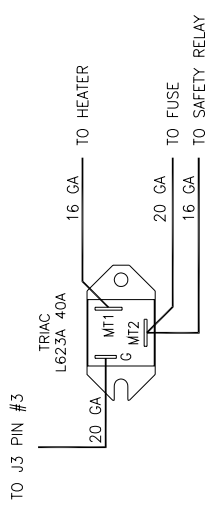
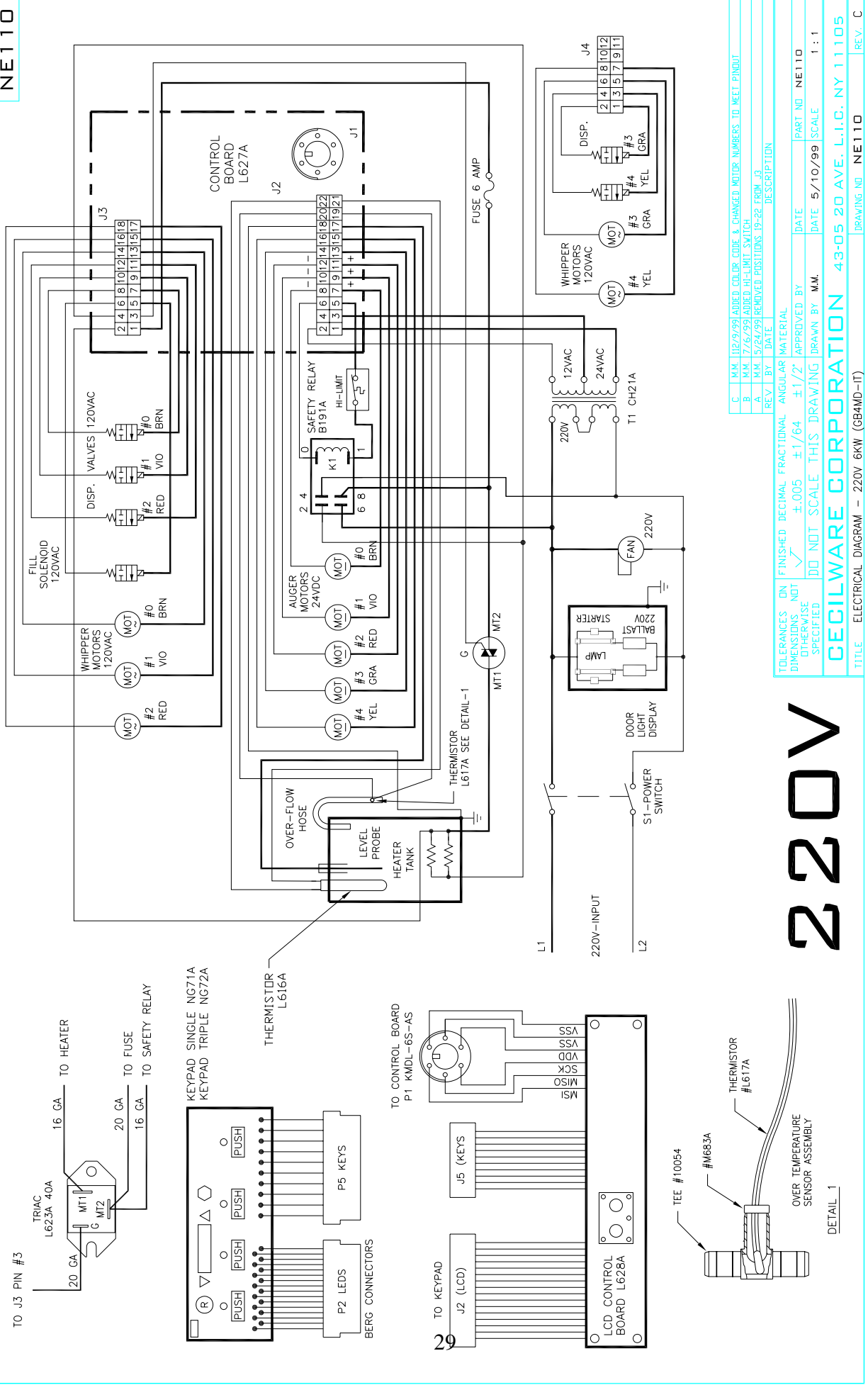

DETAIL 1

REV.	BY	DATE	DESCRIPTION
C	MM	11/2/99	ADDED COLOR CODE & CHANGED MOTOR NUMBERS TO MEET PRINTOUT
B	MM	12/6/99	ADDED HI-LIMIT SWITCH
A	MM	12/2/99	REMOVED POSITIONS 19-22 FROM J3

TOLERANCES UNLESS OTHERWISE SPECIFIED	FINISHED DIMENSIONS	DECIMAL	FRACTIONAL	ANGULAR MATERIAL	APPROVED BY	DATE	PART NO
±0.005	±1/64	±1/2°			MM	5/10/99	NE110

DO NOT SCALE THIS DRAWING	SCALE	1 : 1
<p>Cecilware Corporation 43-05 20 AVE. L.I.C. NY 11105</p> <p>TITLE ELECTRICAL DIAGRAM - 220V 6KW (GB4MD-I)</p> <p>DRAWING NO. NE110 REV. C</p>		

220V

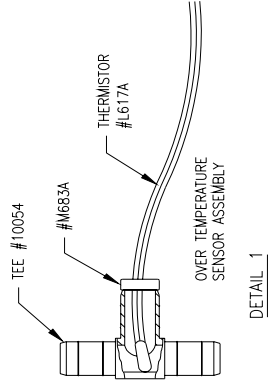
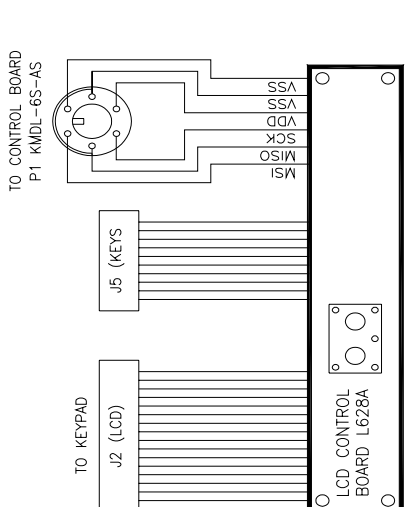
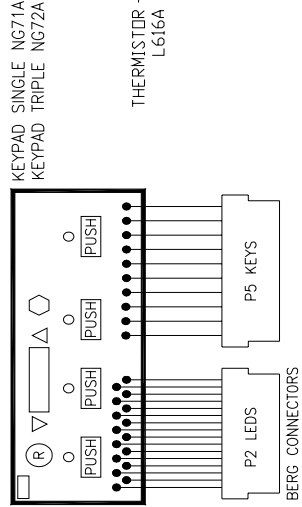
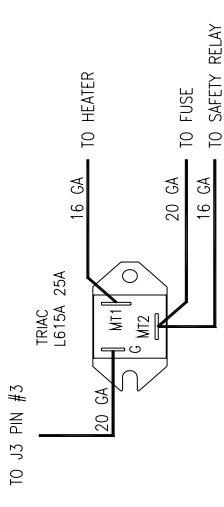
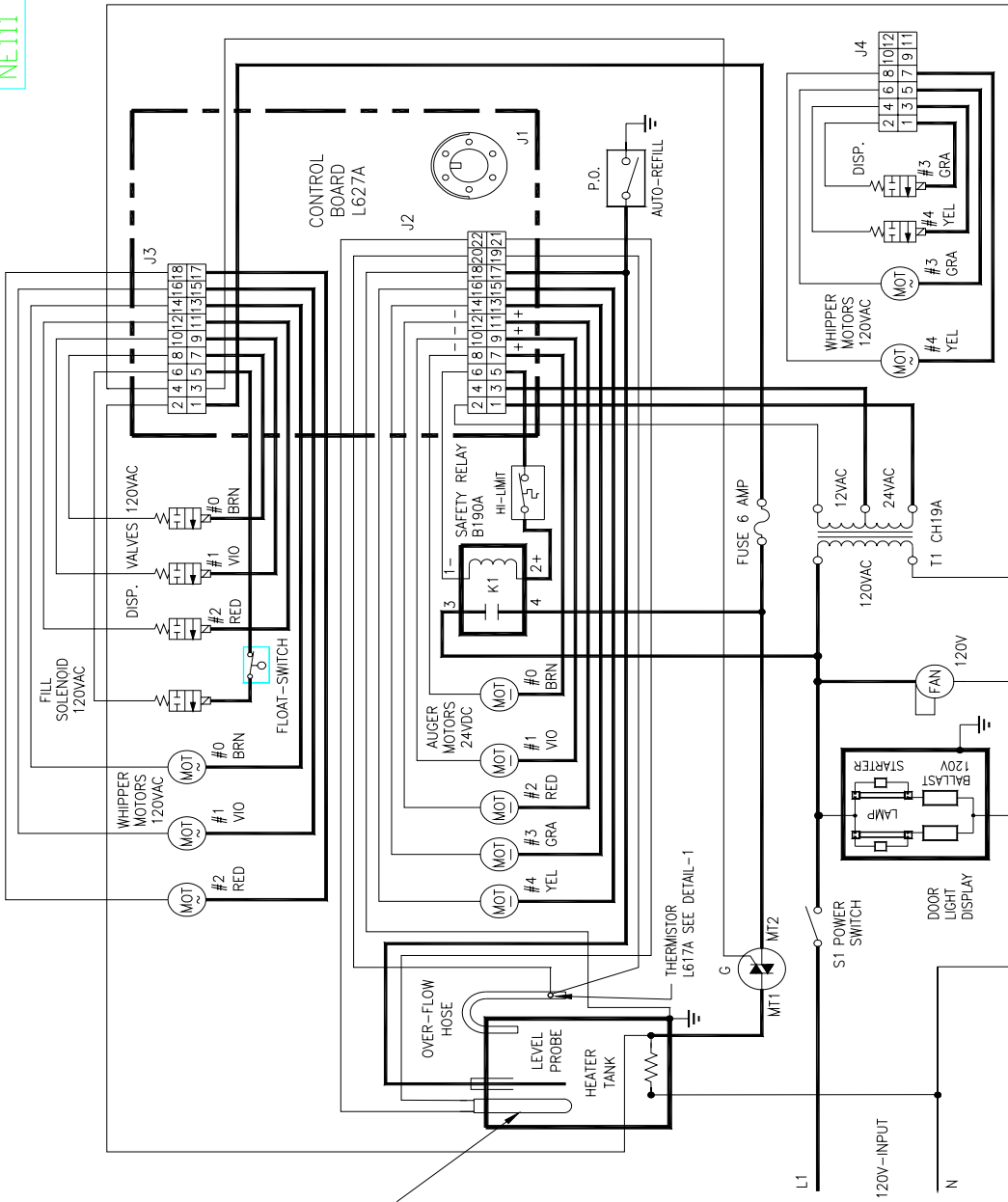

P.O. 120V

D.	MM 12/9/99	ADDED COLOR CODE & CHANGED MOTOR NUMBERS TO MEET PINOUT
C.	MM 7/6/99	ADDED HI-LIMIT SWITCH
B.	MM 16/28/99	ADDED THERMAL SWITCH
A.	MM 15/24/99	REMOVED POSITIONS 19-22 FROM J3
REV. I BY	DATE	DESCRIPTION

TOLERANCES UNLESS OTHERWISE SPECIFIED	FINISHED DECIMAL	FRACTIONAL	ANGULAR MATERIAL
	±.005	±1/64	±1/2°

APPROVED BY	DATE	PART NO.
MM	5/11/99	NE111
DRAWN BY	DATE	SCALE
MM	5/11/99	1:1

CECILWARE CORPORATION 43-05 20 AVE. L.I.C. NY 11105
 TITLE ELECTRICAL DIAGRAM - 120V (GBA-IT P.O.)
 DRAWING NO NE111 REV. D

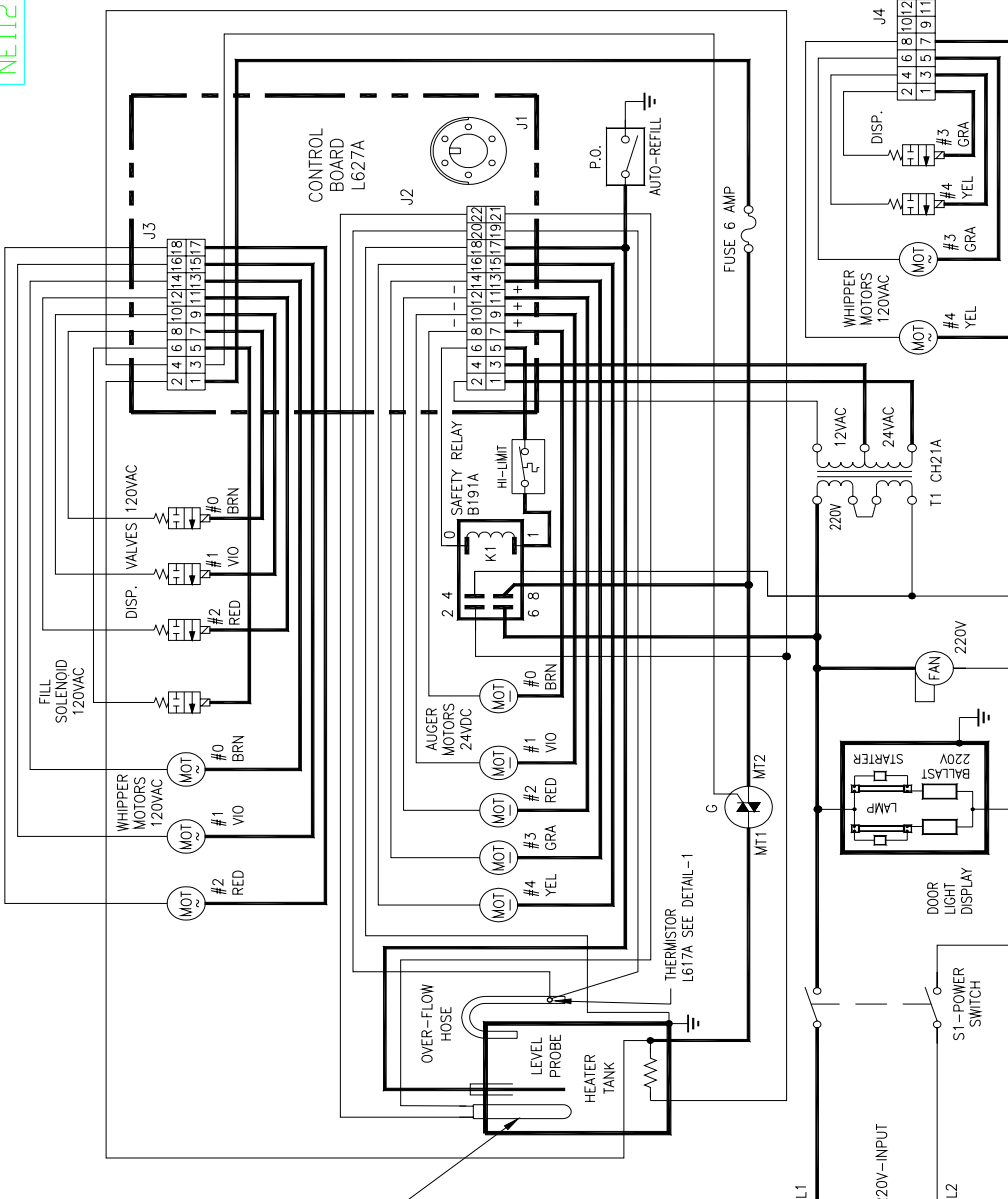
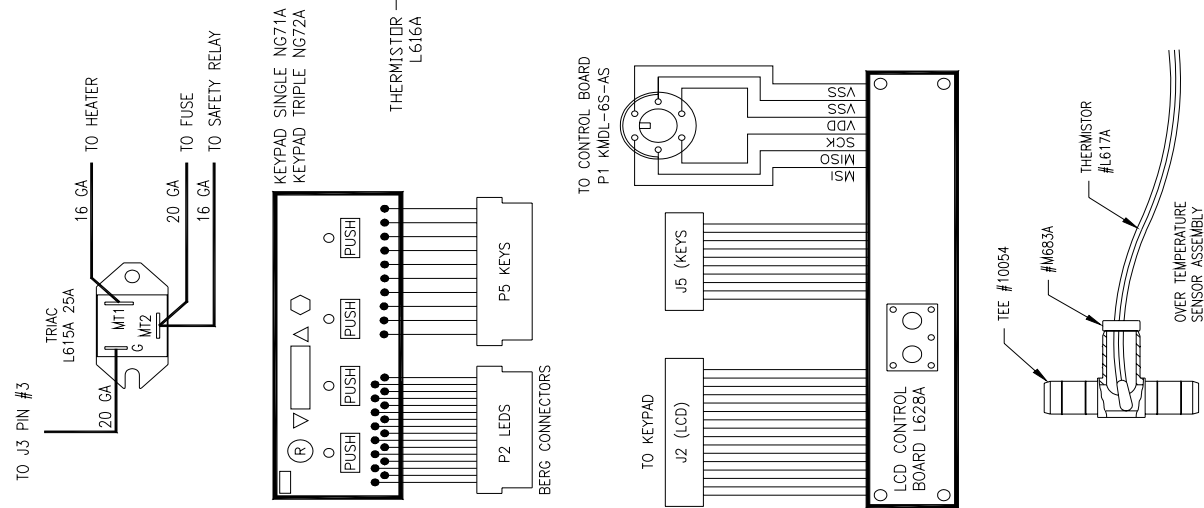

P.O. 220V

REV	BY	DATE	DESCRIPTION
C	M.M.	11/27/99	ADDED COLOR CODE & CHANGED MOTOR NUMBERS TO MEET PRODUCT
B	M.M.	7/6/99	ADDED HI-LIMIT SWITCH
A	M.M.	5/24/99	REMOVED POSITIONS 19-22 FROM J3

TOLERANCES	FINISHED	DECIMAL	FRACTIONAL	ANGULAR	MATERIAL
DIMENSIONS	NOT	±.005	±1/64	±1/2°	APPROVED BY
OTHERWISE SPECIFIED	DO NOT SCALE THIS DRAWING	DATE	DATE	DATE	DATE

TITLE: ELECTRICAL DIAGRAM - 220V, 3KW (GB3MD-IT P.O.)
 DRAWING NO. NE112
 PART NO. NE112
 SCALE 1:1
 DATE 5/11/99
 DRAWN BY M.M.
 43-05 20 AVE. L.I.C. NY 11105

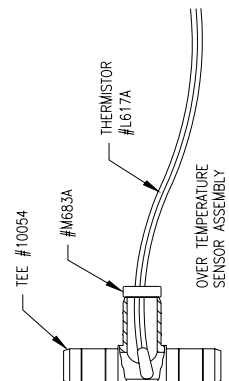
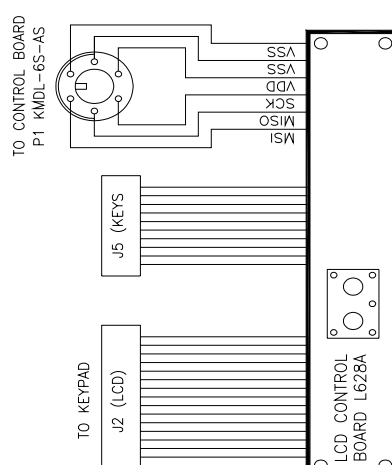
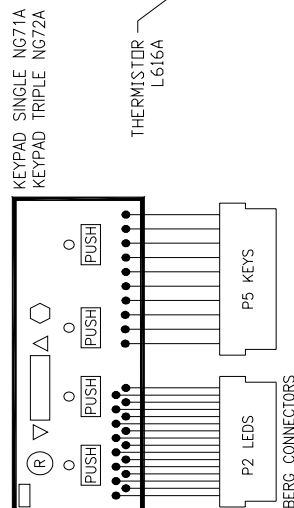
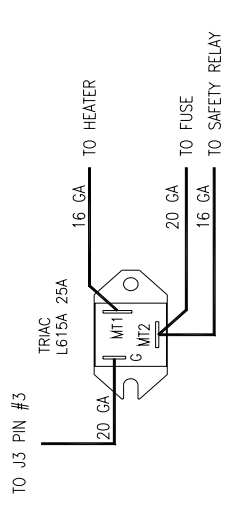
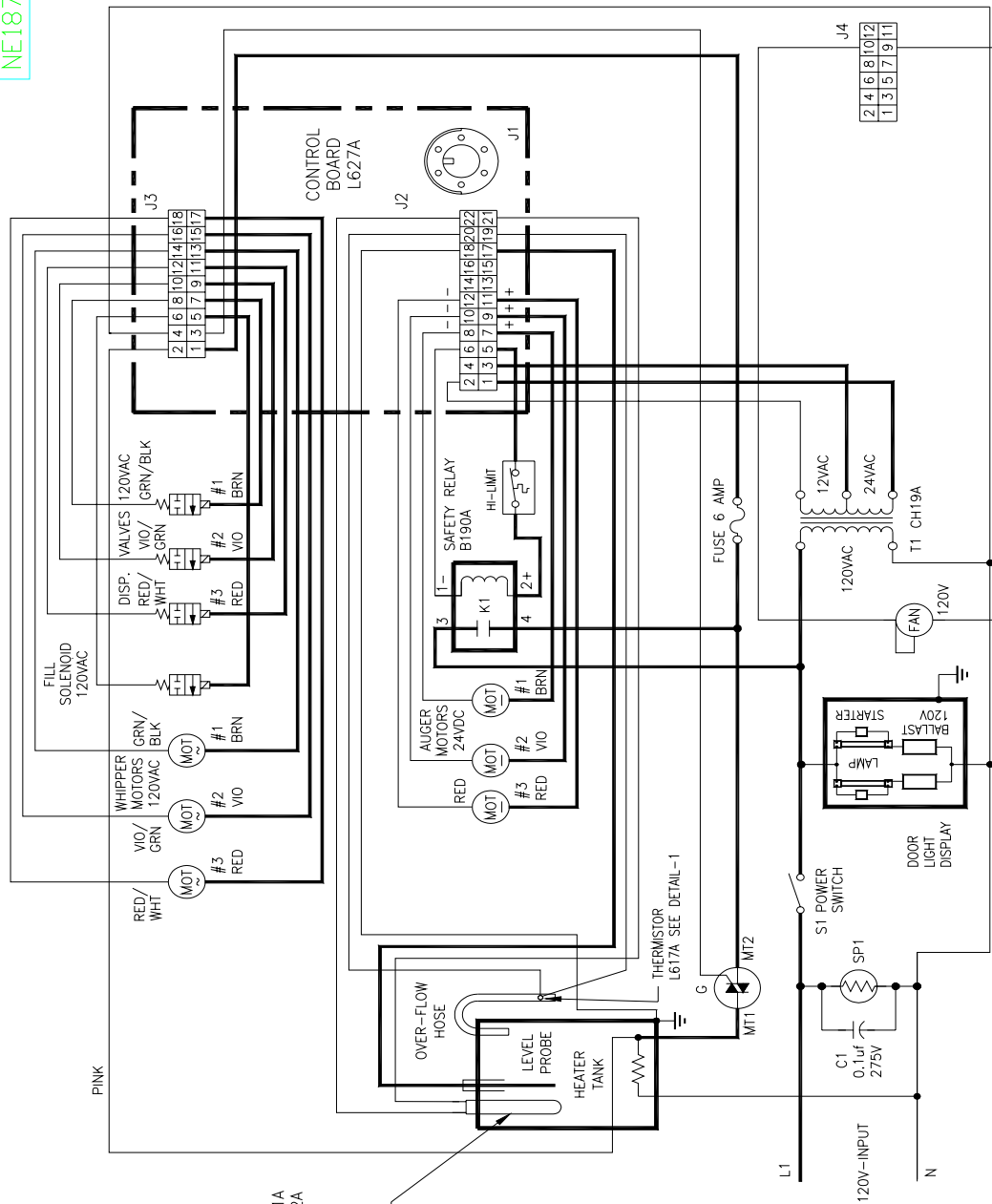

120V

REV.	BY	DATE	DESCRIPTION
1	MM	5/21/2002	DO NOT SCALE THIS DRAWING

TOLERANCES UNLESS OTHERWISE SPECIFIED	±.005	±1/64	±1/2"
APPROVED BY	DATE	PART NO	SCALE
MM	5/21/2002	NE187	1 : 1

TITLE	ELECTRICAL DIAGRAM - 120V (GB3MD-I)	DRAWING NO.	NE187
CUSTOMER	CECILWARE CORPORATION	ADDRESS	43-05 20 AVE. L.I.C. NY 11105

USING OLDER VERSION OF TOUCH PAD WITH ONE RIBBON CONNECTOR

NE94A

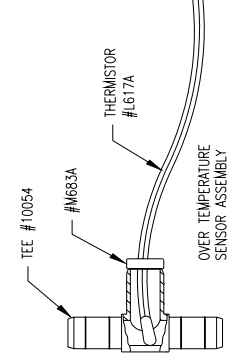
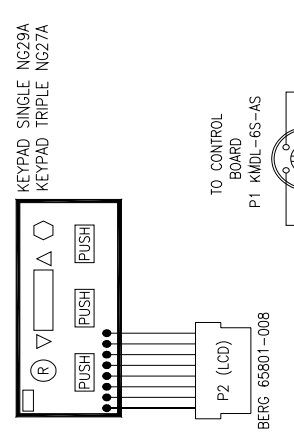
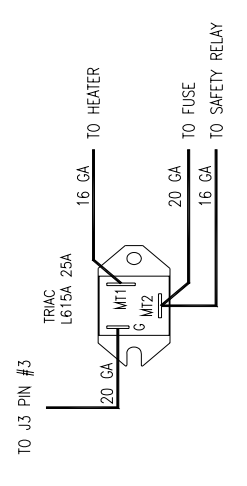
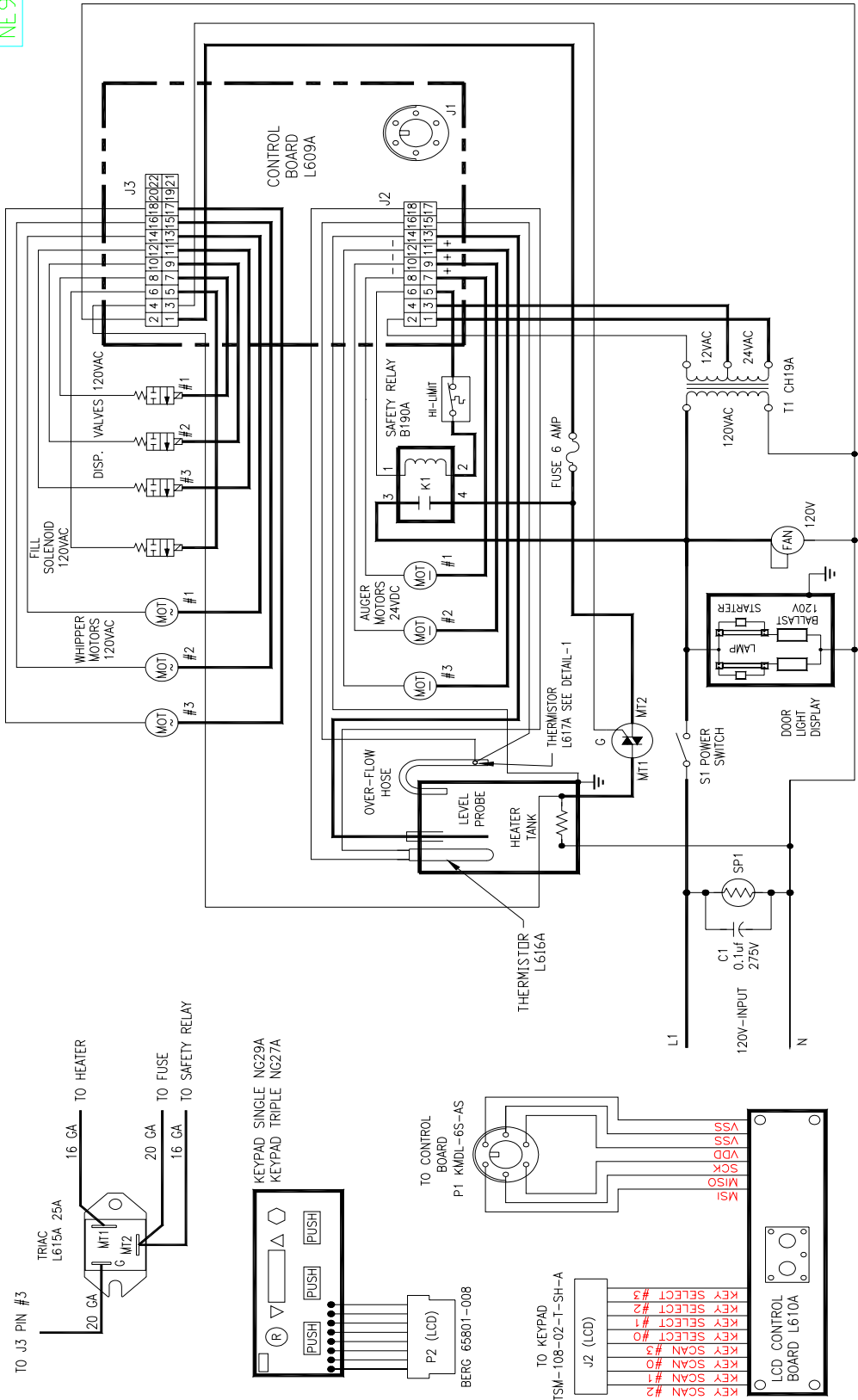

REV.	BY	DATE	DESCRIPTION
B	MM, 1/27/2008	MOVED CI & SPI	
A	MM, 7/26/99	ADDED HI-LIMIT SWITCH	

TOLERANCES UNLESS OTHERWISE SPECIFIED	FINISHED DECIMAL	FRACTIONAL	ANGULAR	MATERIAL
✓	±.005	±1/64	±1/2°	APPROVED BY
DO NOT SCALE THIS DRAWING	DRAWN BY	MM	DATE	11/23/98
SCALE	1 : 1			

TITLE	ELECTRICAL DIAGRAM - 120V (GR3-IT)
PART NO	NE94A
DATE	11/23/98
SCALE	1 : 1
DRAWING NO	NE94A
REV.	B

120V

USING OLDER VERSION OF TOUCH PAD WITH ONE RIBBON CONNECTOR

NE95A

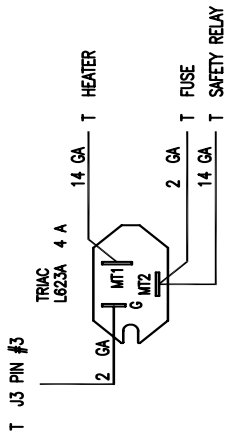
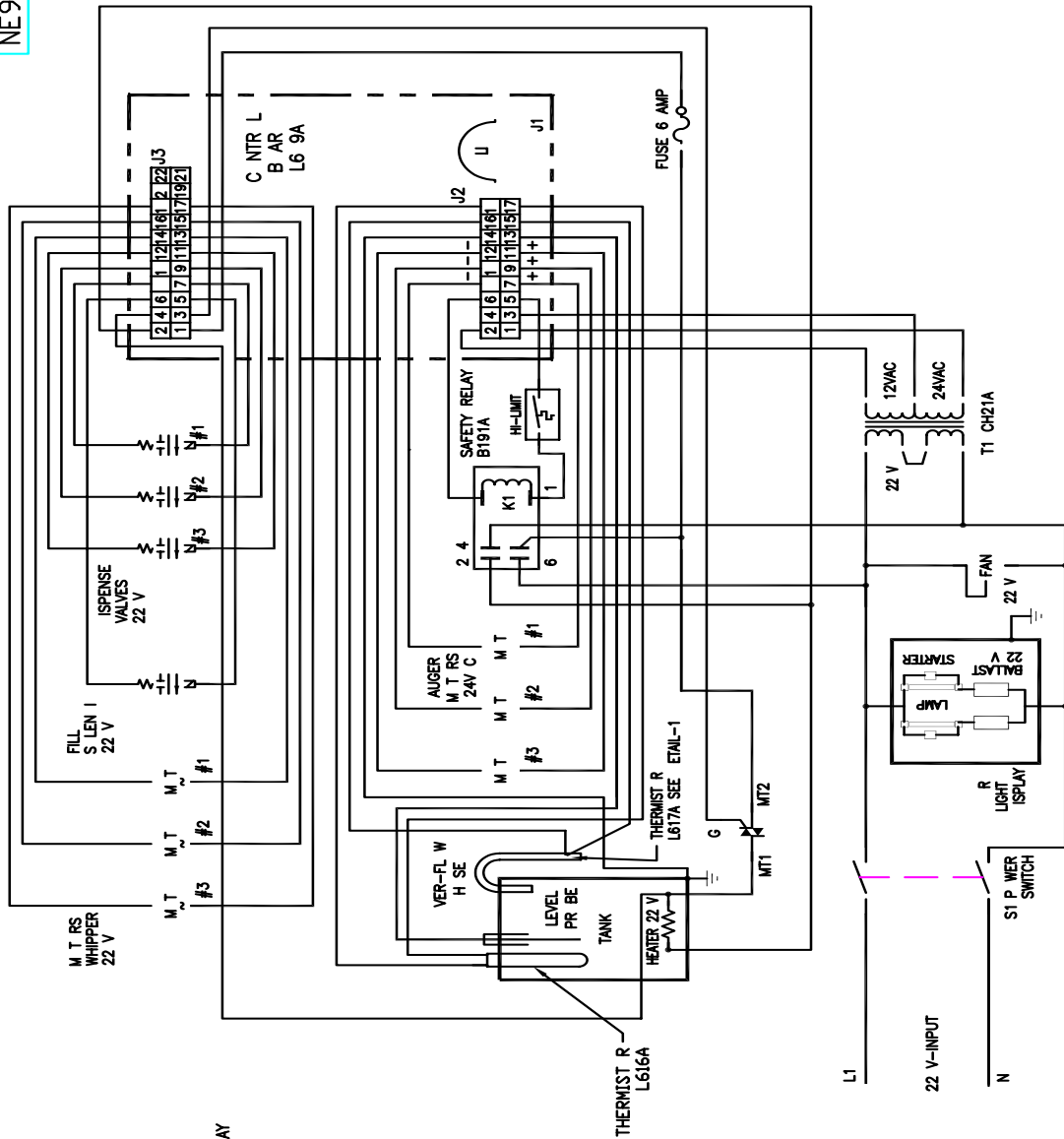

KEYPA SINGLE NG29A
 KEYPA TRIPLE NG27A

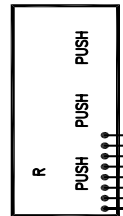

T C NTR L
 B AR
 P1 KM L-6S-AS

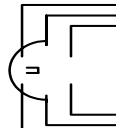

T KEYPA
 TSM-1 - 2-T-SH-A

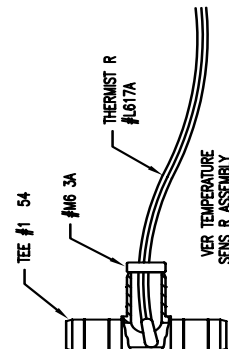
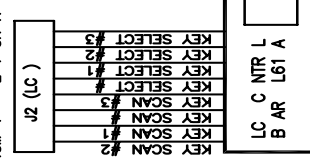

220V

A: PMS 7/26/99 ADDED J3 PIN #3 SWITCH		DESCRIPTION	
REV BY	DATE	DATE	DATE
TOLERANCES UNLESS OTHERWISE SPECIFIED		FINISHED DECIMAL FRACT NML ANGULAR MATERIAL	
DIMENSI	NS	N	T
±	5	±1/64	±1/2
APPR	VED BY	DATE	DATE
DRAWN BY GW		DATE	1/14/99
SCALE		1 1	
CECILWARE CORPORATION 43-05 20 AVE. L.I.C. NY 11105			
TITLE ELECTRICAL WIRING - 22 V (GB3-IT)		DRAWING NO. NE95A	
		REV. A	