

Champion[®]

Installation Manual



PRO Series Rack Conveyor Dishwashers

STANDARD MODELS

44 PRO	66PRO	66 PRO FF	80 PRO HD
54 PRO	76 PRO	76 PRO FF	90 PRO HD

Ventless Heat Recovery

VHR MODELS

44 PRO VHR	66 PRO VHR	66 PRO FF VHR	80 PRO HD VHR
54 PRO VHR	76 PRO VHR	76 PRO FF VHR	90 PRO HD VHR



Issue Date: 9.6.23

Manual P/N 117684 rev. -

For machines beginning with S/N RP23014148 and above

www.championindustries.com

3765 Champion Boulevard
Winston-Salem, NC 27105
(336) 661-1556 Fax: (336) 661-1660
Toll-free: 1(800) 858-4477

2674 N. Service Road, Jordan Station
Ontario, Canada L0R 1S0
(905) 562-4195 Fax: (905) 562-4618
Toll-free: 1(800) 263-5798

Printed in the USA



The Spirit of Excellence

National Service Department

In Canada:

Toll-free: (800) 263-5798
Tel: (905) 562-4195
Fax: (905) 562-4618
email: service@moyerdiebellimited.com

In the USA:

Toll-free: (800) 858-4477
Tel: (336) 661-1556
Fax: (336) 661-1660
email: service@championindustries.com

ATTENTION

The model no., serial no., voltage, Hz and phase are needed to identify your machine and to answer questions.

**The machine data plate
is located on the side of
the top-mounted control panel.**

Please have this information ready if you call for service assistance.

Three ways to **REGISTER YOUR PRODUCT and ACTIVATE YOUR WARRANTY.**

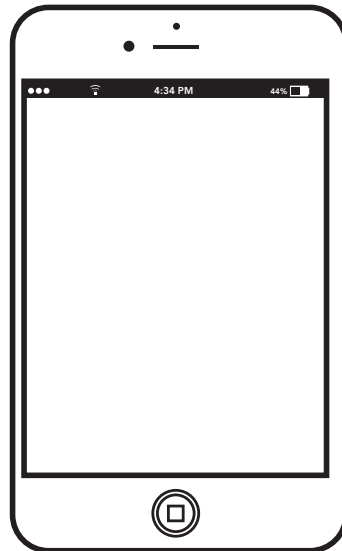

- Use your mobile phone or computer and go to the website at www.championindustries.com and register your product.
- or
- Scan the QR code <http://champdw.us/PRO> located near the data plate.
- or
- Use the fax form on the next page.

PRODUCT REGISTRATION BY FAX

COMPLETE THIS FORM AND FAX TO:

(336) 661-1660 in the USA

1-(800) 204-0109 in Canada

PRODUCT REGISTRATION CARD

Model

Serial #

Date of Installation: ___/___/___

Company Name: _____

Address: _____
(Street) State/Province Zip/Postal Code

Telephone #: () _____ --- _____

Contact: _____

Installation Company: _____

Address: _____

Telephone #: _____

Contact: _____

FAILURE TO REGISTER YOUR PRODUCT MAY VOID YOUR WARRANTY

IMPORTANT IMPORTANT

Limited Warranty

LIMITED WARRANTY

Champion Industries (herein referred to as “The Company”), 3765 Champion Blvd., Winston-Salem, North Carolina 27105, and 2674 N. Service Road, Jordan Station, Ontario, Canada, L0R 1S0, warrants machines, and parts, as set out below.

Warranty of Machines: The Company warrants all new machines of its manufacture bearing the name “Champion and installed within the United States and Canada to be free from defects in material and workmanship for a period of one (1) year after the date of installation or fifteen (15) months after the date of shipment by The Company, whichever occurs first. [See below for special provisions relating to glasswashers.] Warranty registration must be submitted to The Company within ten (10) days after installation either online on the Champion Industries website (<http://www.championindustries.com>, in the USA or <http://www.championindustries.com/canada> in Canada or by registering with the QR code on the machine at <http://champdw.us/PRO> or by the fax form provided at the front of this manual. The Company will not assume any responsibility for extra costs for installation in any area where there are jurisdictional problems with local trades or unions.

If a defect in workmanship or material is found to exist within the warranty period, The Company, at its election, will either repair or replace the defective part or accept return of the machine for full credit; provided; however, as to glasswashers, The Company’s obligation with respect to labor associated with any repairs shall end (a) 120 days after shipment, or (b) 90 days after installation, whichever occurs first. In the event that The Company elects to repair, the labor and work to be performed in connection with the warranty shall be done during regular working hours by a Champion authorized service technician. Defective parts become the property of The Company. Use of replacement parts not authorized by The Company will relieve The Company of all further liability in connection with its warranty. In no event will The Company’s warranty obligation exceed The Company’s charge for the machine. The following are not covered by The Company’s warranty:

- a. Lighting of gas pilots or burners.
- b. Cleaning of gas lines.
- c. Replacement of fuses or resetting of overload breakers.
- d. Adjustment of thermostats.
- e. Adjustment of clutches.
- f. Opening or closing of utility supply valves or switching of electrical supply current.
- g. Cleaning of valves, strainers, screens, nozzles, or spray pipes.
- h. Performance of regular maintenance and cleaning as outlined in the operator’s guide.
- i. Damages resulting from water conditions, accidents, alterations, improper use, abuse, tampering, improper installation, or failure to follow maintenance and operation procedures.
- j. Wear on Pulper cutter blocks, pulse vanes, and auger brush.

Examples of the defects not covered by warranty include, but are not limited to: (1) Damage to the exterior or interior finish as a result of the above, (2) Use with utility service other than that designated on the rating plate, (3) Improper connection to utility service, (4) Inadequate or excessive water pressure, (5) Corrosion from chemicals dispensed in excess of recommended concentrations, (6) Failure of electrical components due to connection of chemical dispensing equipment installed by others, (7) Leaks or damage resulting from such leaks caused by the installer, including those at machine table connections or by connection of chemical dispensing equipment installed by others, (8) Failure to comply with local building codes, (9) Damage caused by labor dispute.

Warranty of Parts: The Company warrants all new machine parts produced or authorized by The Company to be free from defects in material and workmanship for a period of 90 days from date of invoice. If any defect in material and workmanship is found to exist within the warranty period The Company will replace the defective part without charge.

DISCLAIMER OF WARRANTIES AND LIMITATIONS OF LIABILITY. THE COMPANY’S WARRANTY IS ONLY TO THE EXTENT REFLECTED ABOVE. THE COMPANY MAKES NO OTHER WARRANTIES, EXPRESS OR IMPLIED, INCLUDING, BUT NOT LIMITED, TO ANY WARRANTY OF MERCHANTABILITY, OR FITNESS OF PURPOSE. THE COMPANY SHALL NOT BE LIABLE FOR INCIDENTAL OR CONSEQUENTIAL DAMAGES. THE REMEDIES SET OUT ABOVE ARE THE EXCLUSIVE REMEDIES FOR ANY DEFECTS FOUND TO EXIST IN THE COMPANY’S DISHWASHING MACHINES AND THE COMPANY’S PARTS, AND ALL OTHER REMEDIES ARE EXCLUDED, INCLUDING ANY LIABILITY FOR INCIDENTALS OR CONSEQUENTIAL DAMAGES.

The Company does not authorize any other person, including persons who deal in Champion dishwashing machines to change this warranty or create any other obligation in connection with Champion dishwashing machines.

INSTALLATION CODES

The installation of the dishwasher must comply with all local electrical, plumbing, health and safety codes or in the absence of local codes, installed in accordance with the applicable requirements in the National Electrical Code, NFPA 70, Canadian Electrical Code (CEC), Part 1, CSA C22.1; and the Standard for Ventilation Control and Fire Protection of Commercial Cooking Operations, NFPA 96.



CAUTION:

Only qualified personnel familiar with the installation of food service equipment should attempt the installation of this machine. Damage or problems associated with improper installation will not be covered by the dishwasher limited warranty.

Water Softener Systems

Water softening systems must be approved by Champion prior to installation. Operating requirements considered, but not limited to must be: 1) water temperature and pressure, (2) water consumption, (3) system pressure drop. Consult the Water Softener Manufacturer and Champion Industries before specifying the installation.



NOTE:

A commercial grade NON-CHLORINATED must be used in all model machines.

Safety Symbols

The following symbols are used throughout this manual to alert the reader to important information.



WARNING:

Warning statements indicate a condition or practice that can result in personal injury or possible death.



CAUTION:

Caution statements indicate a condition or practice that can result in damage to the machine or associated equipment.



NOTE:

Note statements highlight important information necessary for the operation of the machine.

Revision History

Specifications are subject to change based on continual product improvement. Equipment owners may request a printed manual at no charge by calling 1 (800) 858-4477 in the USA or 1(800) 263-5798 in Canada.

<i>Revision Date</i>	<i>Revised Pages</i>	<i>Serial Number Effectivity</i>	<i>Description</i>
9.6.23	All	RP23014148	Released Second Edition

**This page was
intentionally
left blank.**

Table of Contents

Limited Warranty	i
Installation Codes and Safety Symbols	ii
Water Softener Systems.....	ii
Revision History.....	iii
Basic Machine Models.....	vi

Installation..... 1

Receiving and Placement.....	1
VHR Heat Pump (HP) Mounting.....	2
Dish Table Connections.....	4
Optional Table Limit Switch, (TLS)	5
Hot Water Connection	6
Cold Water Connection	7
Optional Mechanical Drain Water Termpering.....	8
ION Scale Prevention System.....	8
Drain Connection.....	9
Steam Connection.....	11
Ventilation.....	12
Detergent Dispenser Connection (by others)	17
Rinse-aid Dispenser Connection (by others).....	18
Electrical Connections.....	14
Built-in Electric Booster Conversion from 21kW to 12kW	16
Check Motor Rotation.....	17

APPENDEXES 16

Appendix A: Directlink Connectivity	20
Appendix B: Stridelinx Troubleshooting Guide	28
Appendix C: ION Water Conditioner	38

BASIC MACHINE MODELS



44PRO
(Left to right shown)



44PRO VHR
(Left to right shown)

44PRO - Single tank 44" (Electric or Steam Heat)

44PRO VHR - Single Tank 44" Ventless Heat Recovery (Electric Only)

66PRO - Single Tank 44" w/22" Prewash (Electric or Steam Heat)

66PRO FF - Single Tank 44" w/22" Prewash, Front Feed (Electric or Steam Heat)

66PRO FF VHR - Single tank 44" w/22" Prewash, Front Feed (Electric Only)

66PRO VHR - Single tank 44" w/22" Prewash, Ventless Heat Recovery
(Electric or Steam Heat)

80PRO HD - Single tank 44" w/36" Prewash, Heavy Duty (Electric Only)

80PRO HD VHR - Single tank 44" w/36" Prewash, Heavy Duty, Ventless Heat Recovery
(Electric Only)



54PRO
(Right to left shown)



54PRO VHR
(Right to left shown)

54 PRO - Single tank 54" (Electric or Steam Heat)

54 PRO VHR - Single Tank 54" Ventless Heat Recovery (Electric Only)

76 PRO - Single Tank 54" w/22" Prewash (Electric or Steam Heat)

76 PRO FF - Single tank 54" w/22" Prewash, Front Feed (Electric or Steam Heat)

76 PRO VHR - Single tank 54" w/22" Prewash, Ventless Heat Recovery (Electric Only)

76 PRO FF VHR - Single tank 54" w/22" Prewash Ventless Heat Recovery (Electric Only)

90 PRO HD - Single tank 54" w/36" Prewash, Heavy Duty (Electric or Steam Heat)

90 PRO HD VHR - Single tank 54" w/36" Prewash, Heavy Duty, Ventless Heat Recovery
(Electric Only)

RECEIVING - Register your machine online or fax when machine is received.



1. Inspect machine for damage and immediately report to a supervisor.
2. Compare the site utilities with machine utilities..
3. Do not remove machine tags until installation is complete.
4. Check dishwasher interior for curtains, panels and hardware kits.

PLACEMENT



CAUTION:

Do not move machine using drain valve or drain piping.

1. Lift dishwasher off shipping pallet and place near its permanent location.
2. Adjust the height and level of the machine using the adjustable legs.
3. Level the machine from side-to-side and front-to-back.
4. Nominal wall clearance is 6" [152.4 mm] from wall to machine for all models, (see Fig. 2).
5. The heat pump assembly must be installed on top of machine before permanent placement.

! ATTENTION !
FOR VHR MODELS
 HEAT PUMP ASSEMBLY
MUST BE INSTALLED BEFORE
 MACHINE PERMANENT
 PLACEMENT.
 Mounting instructions on page 2).

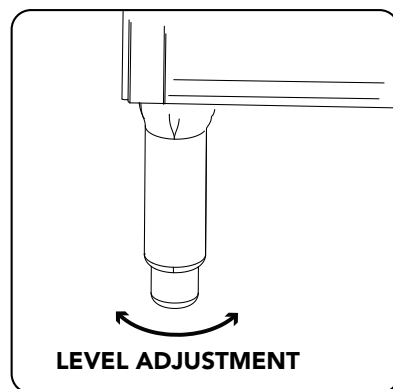

Fig. 1 - Adjustable legs

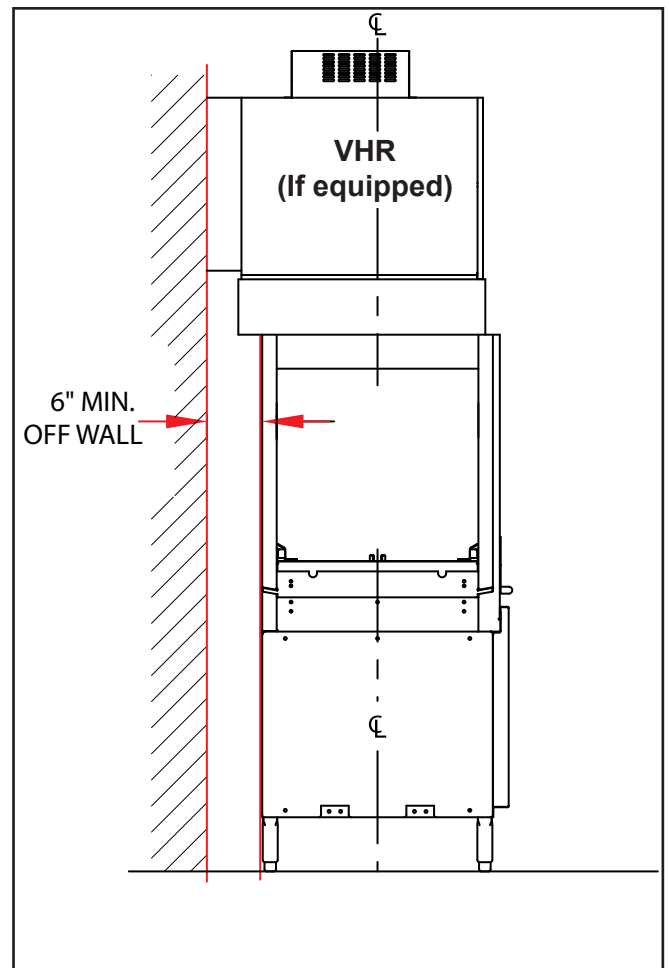

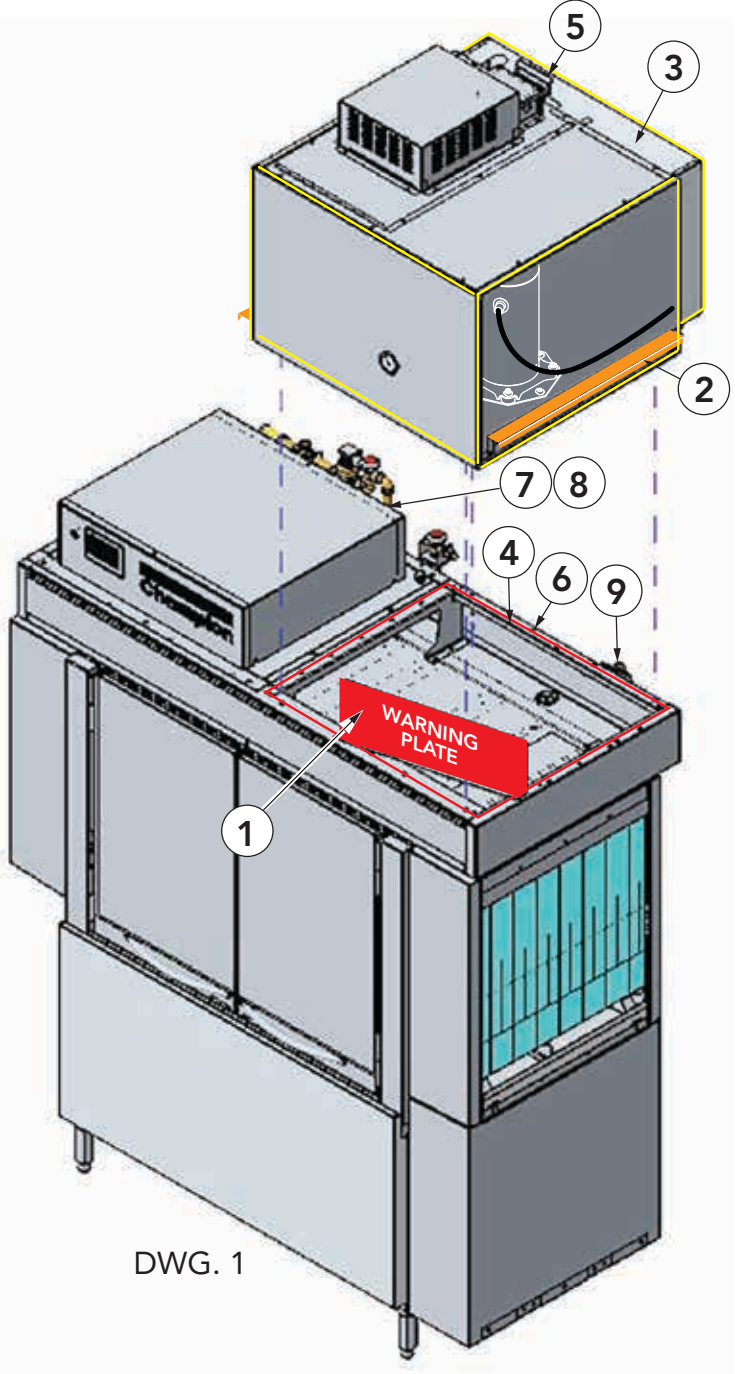
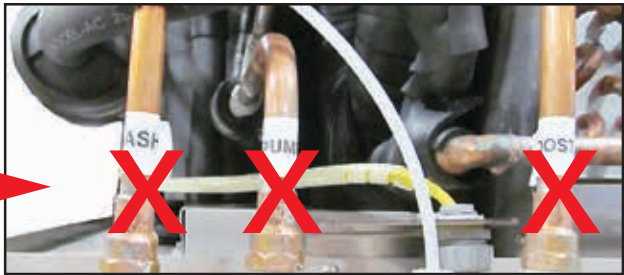

Fig. 2 - Nominal wall clearance for all machine models

VHR Heat Pump (HP) Mounting

	HEAT PUMP MUST BE INSTALLED BY CHAMPION AUTHORIZED SERVICE AGENT TO MAINTAIN WARRANTY PROTECTION.
	DO NOT LIFT WITH REAR COPPER PIPING THIS WILL CAUSE PERMANENT DAMAGE AND VOID THE WARRANTY.
THE HP WEIGHS 300 LBS./136 kg.	



DWG. 1

- REFER TO DWG.1 AT LEFT**
- Step 1:** Remove Warning Plate, (No. 1) & discard.
 - Step 2:** Lift HP with orange handles, (No. 2).
 - Step 3:** Remove yellow panels, (No. 3).
 - Step 4:** Place HP on red opening, (No. 4). Secure with supplied fasteners.
 - Step 5:** Connect plug behind top fan (No. 5).
 - Step 6:** Install conduit bracket (No. 6).
 - Step 7:** Install conduit in rear of cabinet (No. 7).
 - Step 8:** Connect compressor wires #59, #60, and #61 to 4MOL).
 - Step 9:** Connect plastic tube to pressure gauge.
 - Step 10:** Replace yellow panels.

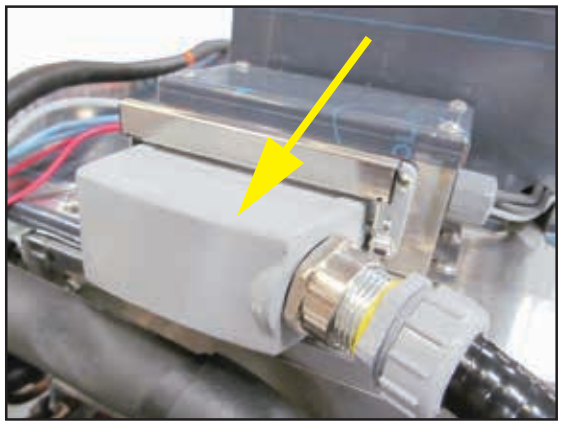

Detail Step 5 - Quick Connect Plug

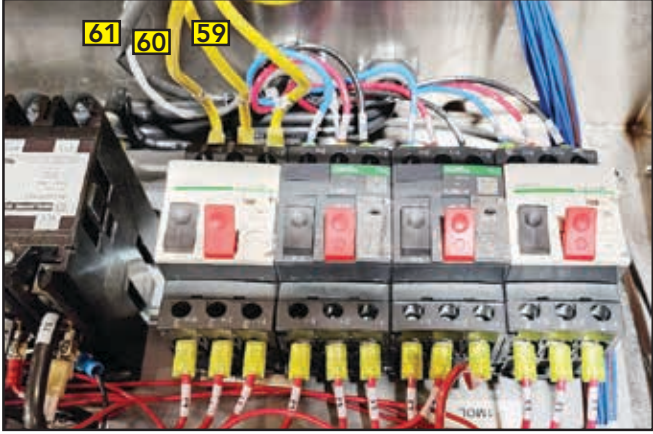

Detail Step 8 -Wires #59, #60, #61

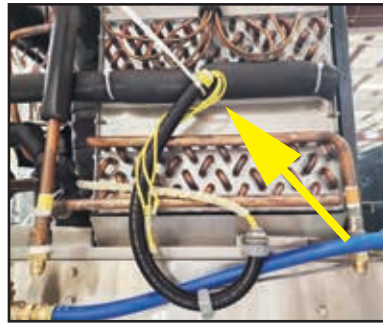
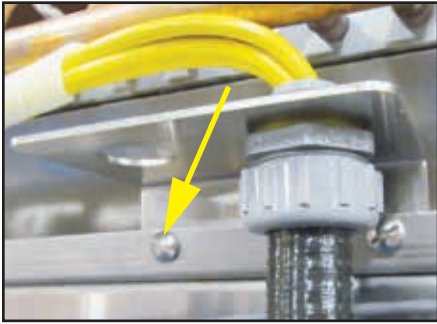

Detail Step 6: Install compressor cable bracket. Route cable to control cabinet.

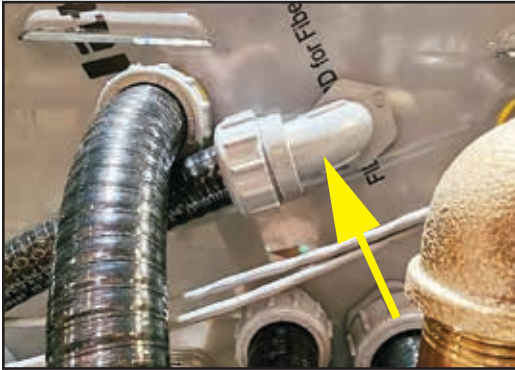

Detail Step 7: Connect cable fitting to rear of cabinet

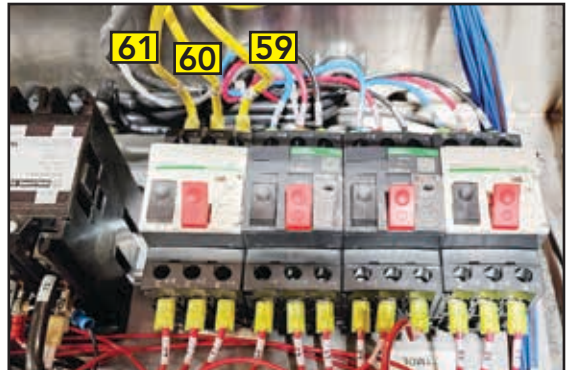

Detail Step 8: Connect compressor wires #59, #60 and #61 to 4MOL overload.



NOTE:

There are three possible connector styles at the compressor. The compressor wires are connected to the compressor at the factory. T1 = #59, T2 = #60, T3 = #61

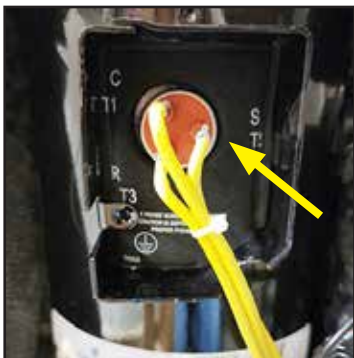

Slip-on terminals



Screw terminals

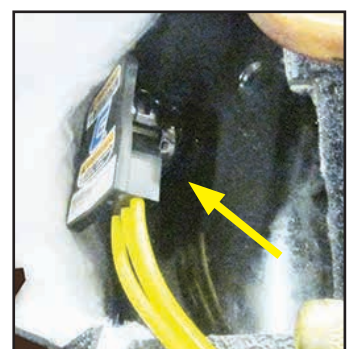

Plug connector

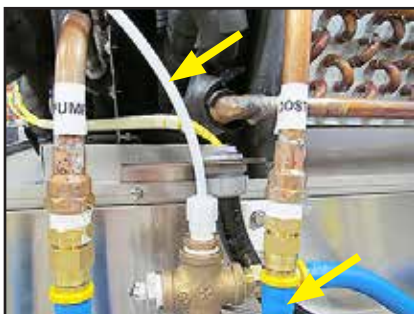

NOTE:

Match colored tape on blue water hoses.

Mounting is complete.

DISH TABLE CONNECTIONS



NOTE:

Tables should be installed after dishwasher is placed in its final location.

1. See Fig. 3 for typical table construction.
2. Level machine, and adjust load height to approximately 34" [864 mm], (Fig. 4).
3. Slope the soiled table away from machine entrance. Slope clean table toward machine to prevent water pooling and exit,
4. Adjust table height until machine track height is approximately 1/4" above the table edge.
5. Set the tables inside the machine making sure the table flange fits against the wash tank wall. Use fasteners, (supplied by others), to attach tables to machine. Apply a bead of silicone sealant to the mating surfaces, (Fig. 5).

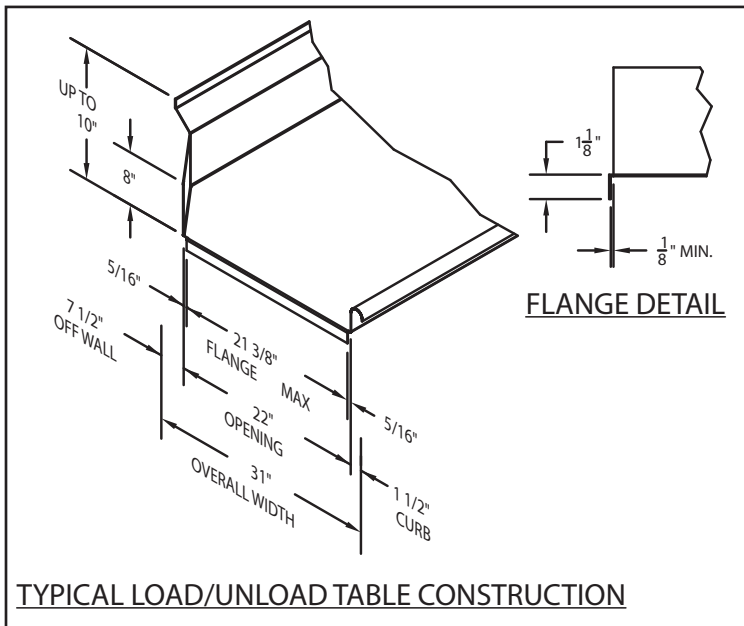

Fig. 3 - Typical table construction.

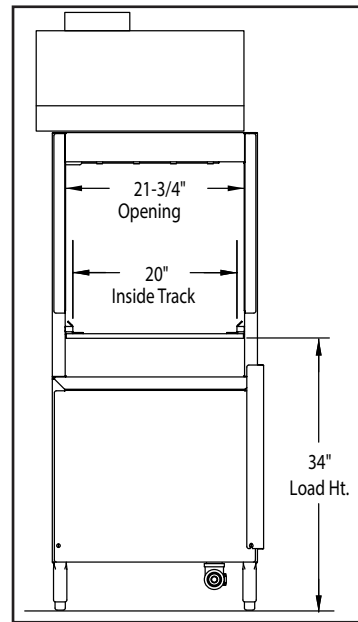

Fig. 4 - Load height.

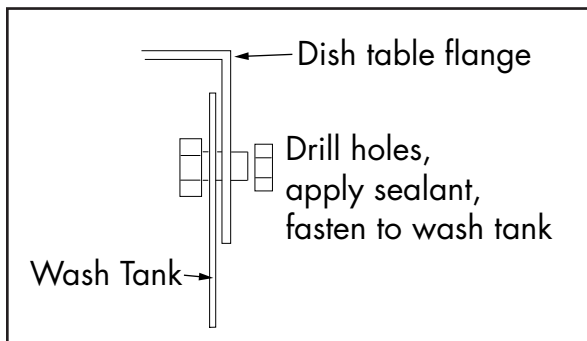

Fig. 5 - Table attachment

OPTIONAL TABLE LIMIT SWITCH, (TLS)

A Table Limit Switch Kit, P/N 407400 is highly recommended to prevent conveyor jams.

The (TLS) is installed on the dishwasher unload table to prevent conveyor jams if dish racks accumulate on the unload table. It stops the conveyor drive until dish racks are removed.

The TLS is shipped inside the machine and must be installed in the field.

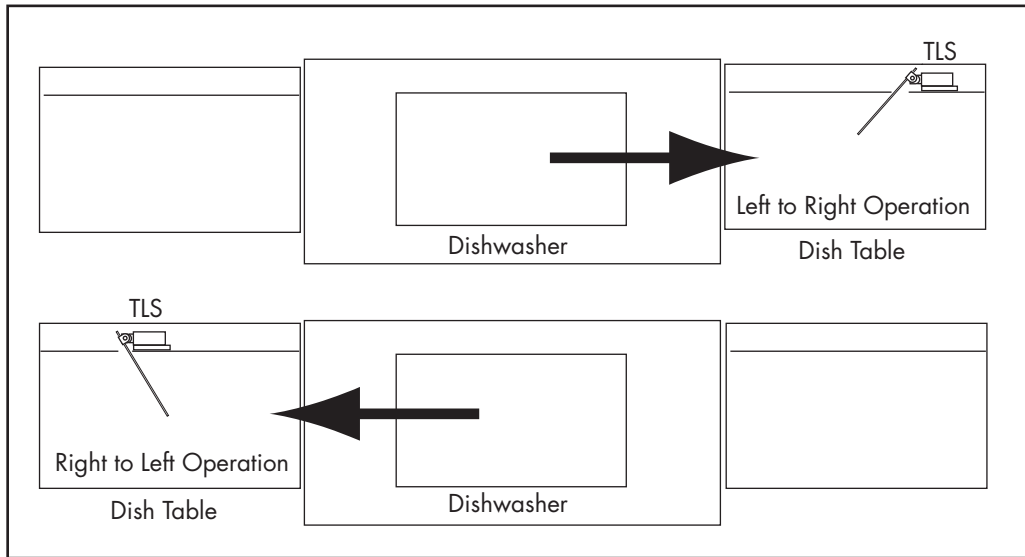

Fig. 6 - Table Limit Switch Installations



NOTE:

Be sure to remove the yellow jumper wire in the lower junction box to enable the TLS.



NOTE:

Be sure to connect the TLS wires in place of the jumper.



Fig. 7 - Table limit switch yellow jumper

PLUMBING - Standard, Heat Recovery and VHR Dishwashers

Hot Water Connection



HOT WATER



CAUTION:

To prevent damage to supply valves, the installing plumber must thoroughly flush debris from water supply line before connecting to the dishwasher. Damage caused by improper installation is not covered by the limited warranty.



NOTE:

CONNECTIONS ARE MARKED WITH TAGS.

Standard

SUPPLY CONNECTION	SUPPLY WATER TEMPERATURE	BOOSTER kW DEGREE RISE	MINIMUM FLOW PSI	WATER CONSUMPTION GAL/HR
1/2" NPT	110°F	21 kW/70°F	20 PSI	100 GAL/HR @ 20 PSI
1/2" NPT	140°F	12 kW/40°F	20 PSI	100 GAL/HR @ 20 PSI
1/2" NPT	180°F	NO BOOSTER	20 PSI	100 GAL/HR @ 20 PSI

VHR

SUPPLY CONNECTION	SUPPLY WATER TEMPERATURE	MAX INCOMING WATER PSI	MINIMUM FLOW PSI
1/2" NPT	110°F	60 PSI	20 PSI

Heat Recovery

SUPPLY CONNECTION	SUPPLY WATER TEMPERATURE	MINIMUM FLOW PSI
1/2" NPT	110°F	20 PSI

- Water hardness of 3 grains/US GAL = 0.83 IMP GAL / 5.3mg/L or less.
- Install a 1/2" or larger shut-off valve in water supply line for servicing.
- For machine without booster, install a pressure regulating valve upstream from the external booster.



Fig. 8 - Standard and Heat Recovery hot water connection



Fig. 9 - Hot water connection no internal booster



Fig.10 - VHR hot water connection

PLUMBING - VHR and Heat Recovery Dishwashers

Cold Water Connection



COLD WATER



NOTE:
CONNECTIONS ARE MARKED WITH TAGS.



CAUTION:

To prevent damage to supply valves, the installing plumber must thoroughly flush debris from water supply line before connecting to the dishwasher.

Damage caused by improper installation is not covered by the limited warranty.

VHR

SUPPLY CONNECTION	SUPPLY WATER TEMPERATURE	MINIMUM FLOW PSI
1/2" NPT	50°F Minimum	40 PSI

Heat Recovery

SUPPLY CONNECTION	SUPPLY WATER TEMPERATURE	MINIMUM FLOW PSI
1/2" NPT	55°F Minimum	30 PSI

- Water hardness of 3 grains/US GAL = 0.83 IMP GAL / 5.3mg/L or less.
- Install a 1/2" or larger shut-off valve in water supply line for servicing.
- VHR and HR machines have an internal booster.

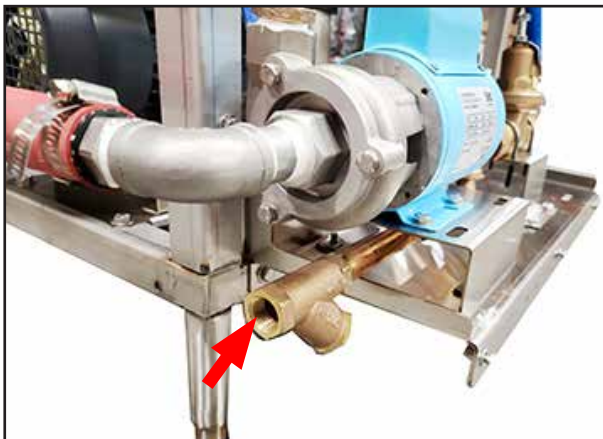

Fig 11 -
VHR cold water connection

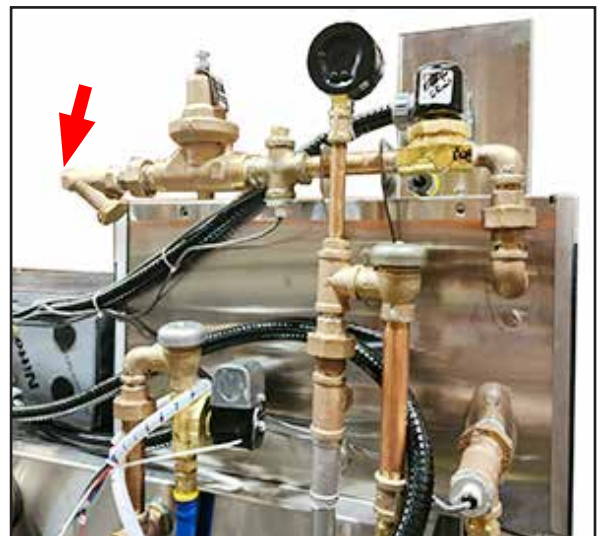

Fig. 12 -
Heat recovery cold water connection

PLUMBING (continued)

Cold Water Connection (continued)



**COLD
WATER**

Optional (DWT), Mechanical Drain Water Tempering

SUPPLY CONNECTION	SUPPLY WATER TEMPERATURE	MAXIMUM INCOMING WATER 60 PSI
1/2" NPT	60-70°F	Install pressure reducing valve, supplied by others, if supply pressure exceeds 60 PSI. Install water hammer arrestor, supplied by others, at supply connection.

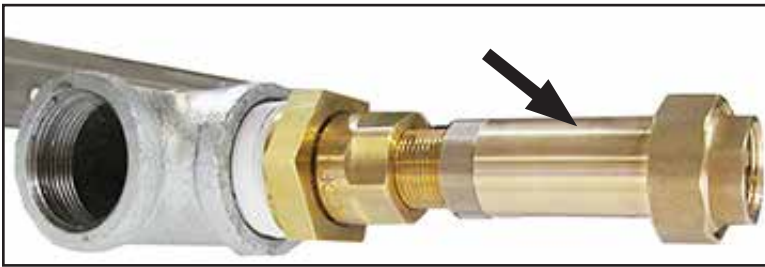

Fig.13 -
Mechanical DWT shown installed in drain line.

The DWT is connected to the drain line to cool machine effluent before it enters the building waste line. It is shipped uninstalled and stowed inside the machine.

Optional "ION" Water Conditioner

The ION water conditioner removes mineral deposits from the incoming water supply to reduce scale build-up inside the dishwasher. It is shipped uninstalled and stowed inside the machine. Refer to Appendix C on page 38 for installation instructions.



Fig.14 -
ION water con (shown uninstalled)

PLUMBING (continued)



Drain Connection



CAUTION:

Drain connections must conform to all local plumbing, safety, and sanitary codes.

CONNECTION	SIZE	MAXIMUM FLOW	VALVE TYPE
GRAVITY	1-1/4" NPT	15 US GPM	ELECTRIC

Drain Connection Locations:

- Drain outlets can be configured to exit on either end of the machine depending on the placement of the end plug fitting.



Fig.15 -
Single tank drain connection



Fig.16 -
Single tank with prewash drain connection

Electric Drain Valve Operation:

- Drain valve sight glass red line indicates when valve is open or closed, (Fig.16).
- Valve opens when power is energized, closes when power is de-energized.

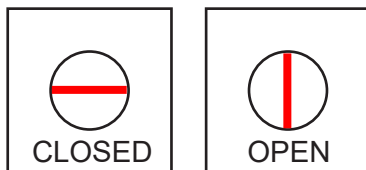

Fig.16 -
Electric drain valve sight glass indicator



NOTE:

Manual operation of drain valve on next page.

Drain Connection (continued)

MANUAL OPERATION OF PRO DRAIN VALVE



- To manually operate the new valve, four 2.5mm socket allen screws must be removed, the valve coil removed, and the valve globe rotated with pliers.

- The valve coil has an indicator line showing valve position. Ensure valve is reassembled in the same position.



1



Remove four 2.5mm coil retaining allen screws.

2



Remove the coil from the valve body.

3



Using pliers, turn the valve body key to the vertical position to open valve.
Reassemble in reverse order.

STEAM CONNECTION - (STANDARD or HR ONLY)



STEAM

- CHECK THE STEAM SUPPLY PRESSURE REQUIREMENTS PRIOR TO CONNECTING STEAM SUPPLY LINE.
- 1-1/4" NPT SUPPLY LINE FOR WASH TANK AND FOR BOOSTER.
- STEAM CONNECTION IS LOCATED ON THE SIDE OF THE MACHINE.
- STEAM CONDENSATE LINE IS 3/4" NPT FOR MACHINE.
- CONDENSATE LINES MUST BE GRAVITY DRAIN WITH NO BACK PRESSURE. A CONDENSATE LIFT PUMP MAY BE REQUIRED IF LINE IS ABOVE THE BASE OF THE MACHINE.

STEAM SUPPLY

- TANK HEAT - LBS./HR. AT 10-30 PSI FLOW PRESSURE = 75 LBS./HR.
- STEAM BOOSTER - LBS./HR. 40-70°F @ 10-30 PSI FLOW PRESSURE = 110 LBS./HR.
- WATER HARDNESS OF 3 GRAINS/US GAL - 0.83 IMP GAL - 5.3 MG/L or LESS

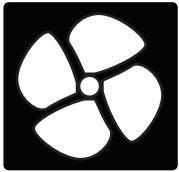

VENTILATION

NOTE:

The HVAC installer shall follow all local ventilation, safety, and sanitary codes.

Ventilation Specifications:

Standard

MACHINE TYPE	Load End CFM @ 1/4" S.P.	Unload End CFM @ 1/4" S.P.
Single Tank	200	400
Single Tank w/Prewash	150	400

Vent stack inside dims. (3.88" x 15.88")

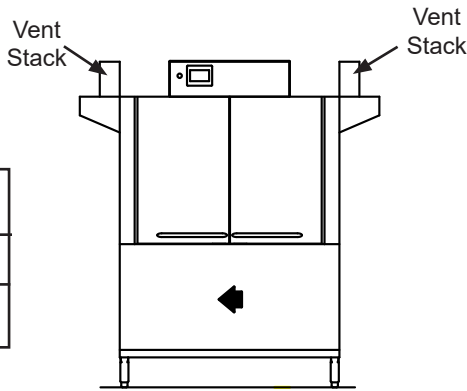

Fig.17 - Standard single tank

Heat Recovery

MACHINE TYPE	Load End CFM @ 1/4" S.P.	Unload End CFM @ 1/4" S.P.
Single Tank	200	200
Single Tank w/Prewash	150	200

Vent stack inside dims. (3.88" x 15.88")

WARNING

PERMANENT FREEZE DAMAGE TO THE DISHWASHER HEAT RECOVERY SYSTEM MAY RESULT IF A POSITIVE VENT PRESSURE IS NOT MAINTAINED WHEN VENT AIR TEMPERATURE AT THE DISHWASHER FALLS BELOW 35°F/1.66°C.

CONSULT AN HVAC PROFESSIONAL TO ENSURE THE DISHWASHER VENTING MEETS THESE REQUIREMENTS.

PIN 117622 rev. -

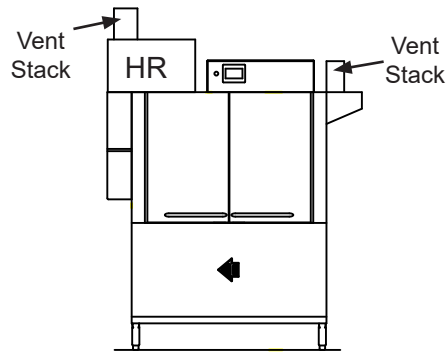

Fig.18 - Single tank heat recovery

VHR - Ventless Heat Recovery

(Does not require venting.)

MACHINE TYPE	Load End CFM @ 1/4" S.P.	Unload End CFM @ 1/4" S.P.
Single Tank	Not Required	Not Required
Single Tank w/Prewash	Not Required	Not Required

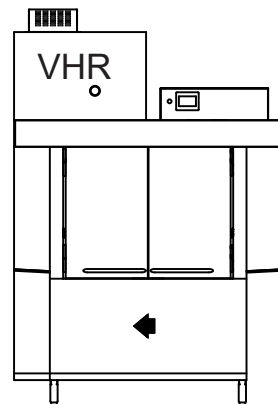

Fig.19 - Single tank ventless heat recovery

VENTILATION (continued)

Vent Stack Damper

- Loosen the handle wingnut and turn the damper handle to open or close the vent damper inside vent stack.
- Adjustments vary for each machine however, when properly adjusted, the load end has an air-draw. The unload end allows a minimum amount of water vapor to exit the machine.



Fig.20 - Vent adjustment

VENT FAN SIGNAL (VF)

- A 120VAC, 0.5A vent fan signal is provided at a fuse block in the main control cabinet, (Fig.21). The 120VAC signal is energized when machine is ON and OVAC when machine is OFF.
- **VHR MODELS DO NOT HAVE A VF FUSE BLOCK or FAN SIGNAL CONNECTION.**



CAUTION:

Do not power a vent fan motor directly from the vent fan signal connection.

CHEMICAL DISPENSING SYSTEM BY OTHERS

DETERGENT SIGNAL (DET)



- A 120VAC, 0.5A detergent signal is provided at a fuse block in the main control cabinet, (Fig.21).
- The signal is enabled when the wash pump runs.
- 7/8" diameter holes are provided in the wash tank for probe and injection.



CAUTION:

Do not power a detergent pump directly from the signal connection.

NOTE:

Use commercial grade NON-CHLORINATED detergent.

RINSE-AID SIGNAL (RA)



- A 120VAC, 0.5A rinse-aid signal is provided at a fuse block in the main control cabinet, (Fig.21).
- The signal is enabled when the final rinse valve is energized.
- Rinse-aid is injected into the final rinse manifold, (Fig. 22).
- Consult chemical supplier for proper chemical.



CAUTION:

Do not power a R/A pump directly from the signal connection.

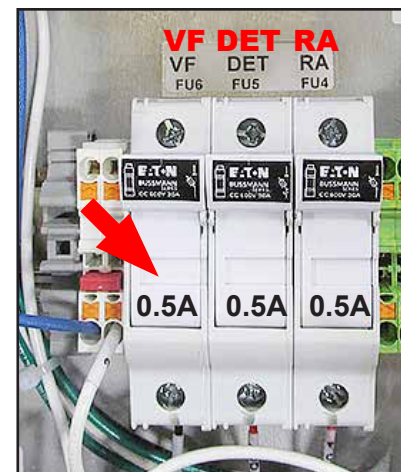

Fig. 21 - Signal connections



Fig. 22 - Final rinse manifold

ELECTRICAL CONNECTIONS



WARNING:

Electrocution hazard! Disconnect power at the main breaker or service disconnect switch before working on circuit. There may be more than one power source connected to the machine.

CHAMPION INDUSTRIES Winston-Salem, N.C., 27105 S/N: RP230712R01		
Mod: 54 PRO	Series: STD.	Volt: 208
Amp: 86	Hz: 60	PH: 3
NSF Requirement Data		
Dishwasher Data		
Final Rinse Flow Pressure	20 P.S.I.	
Rinse Consumption	0.40 Gal./Rack	
Wash Tank Capacity	17 Gal.	
Minimum Final Rinse Temperature	180°F	
Minimum Wash Temperature	160°F	
Conveyor Speed	7.1 F.P.M.	
Pot and Pan Washer Data		
Final Rinse Flow Pressure	20 P.S.I.	
Rinse Consumption	0.40 Gal./Rack	
Wash Tank Capacity	17 Gal.	
Minimum Final Rinse Temperature	180°F	
Minimum Wash Temperature	160°F	
Conveyor Speed	5.4 F.P.M.	

Dishwasher Electrical Connection	
<small>For supply connection, use copper conductors only in accordance with local electrical code, Rated Minimum 90°C (194°F).</small>	
Minimum Supply Conductor Ampacity	70 AMPS
Maximum Supply Overcurrent Protection Device	70 AMPS
Overcurrent Protection Device	Time Delay or Inverse Time Circuit Breaker
Volt: 208	Ph: 3
Hz: 60	Amp: 52
<small>116281</small>	
12kW Booster Electrical Connection	
<small>For supply connection, use copper conductors only in accordance with local electrical code, Rated Minimum 90°C (194°F).</small>	
Minimum Supply Conductor Ampacity	45 AMPS
Maximum Supply Overcurrent Protection Device	45 AMPS
Overcurrent Protection Device	Time Delay or Inverse Time Circuit Breaker
Volt: 208	Ph: 3
Hz: 60	Amp: 34
<small>116249</small>	

Fig. 24 -Connection data plates located adjacent to power input blocks

Fig. 23 - Main data plate on side of top control cabinet



CAUTION:

The machine electrical schematic is rolled up and stowed inside the main control cabinet. **DO NOT TAKE THE SCHEMATIC. LEAVE IT WITH THE MACHINE.**

ELECTRICAL INSTALLATION

1. Remove the top-mounted control cabinet cover and locate the power terminal blocks.
2. Compare the machine electrical specifications and the site before making connections.
3. There are three jumper wires connected between the dishwasher and booster terminal blocks. Refer to Fig. 25 on page 15.

ELECTRICAL CONNECTIONS (continued)

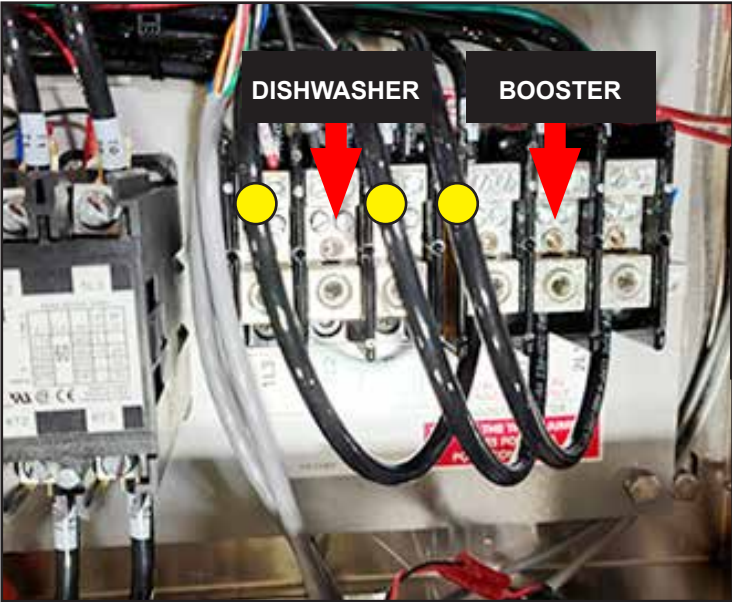

JUMPERS
 THE MACHINE IS A SINGLE POINT CONNECTION IF JUMPERS ARE INSTALLED.

Fig. 25 - Jumpers installed for 1-point connection

- 4. Standard machines are configured as 1-point connection with jumpers.
- 5. Figures 26 and Fig. 27 below illustrate 1-point and 2-point connection labeling at the power terminal blocks.

VHR MACHINES ARE ALWAYS CONFIGURED AS 2-POINT CONNECTIONS AND MUST NOT BE CHANGED.

SINGLE PHASE MACHINES ARE ALWAYS CONFIGURED AS 2-POINT CONNECTIONS.

1L1	1L2	1L3	2L1	2L2	2L3
			BOOSTER HEATER REMOVE THREE JUMPERS FOR DUAL POINT CONNECTION		
Dishwasher Electrical Connection <small>For safety information, see separate literature only. For installation and wiring information, see the Rating Information (R1) label.</small> Maximum Supply Circuit Breaker Capacity: 70 AMP/30 Maximum Supply Circuit Breaker Trip: 70 AMP/30 Overcurrent Protection Device: 70 AMP/30 Time Delay of Overcurrent Protection Device: 30 seconds Voltage: 208 VAC Phase: 3 Rating: 52 Amp/34					

Fig. 26 - 1-point connection labels

1L1	1L2	1L3	2L1	2L2	2L3
			BOOSTER HEATER REMOVE THREE JUMPERS FOR DUAL POINT CONNECTION		
Dishwasher Electrical Connection <small>For safety information, see separate literature only. For installation and wiring information, see the Rating Information (R1) label.</small> Maximum Supply Circuit Breaker Capacity: 70 AMP/30 Maximum Supply Circuit Breaker Trip: 70 AMP/30 Overcurrent Protection Device: 70 AMP/30 Time Delay of Overcurrent Protection Device: 30 seconds Voltage: 208 VAC Phase: 3 Rating: 52 Amp/34			12W Booster Electrical Connection <small>For safety information, see separate literature only. For installation and wiring information, see the Rating Information (R1) label.</small> Maximum Supply Circuit Breaker Capacity: 45 AMP/30 Maximum Supply Circuit Breaker Trip: 45 AMP/30 Overcurrent Protection Device: 45 AMP/30 Time Delay of Overcurrent Protection Device: 30 seconds Voltage: 208 VAC Phase: 3 Rating: 34 Amp/24		

Fig. 27 - 2-point connection labels

(Continued on next page.)

ELECTRICAL CONNECTIONS (continued)

BUILT-IN ELECTRIC BOOSTER CONVERSION from 21kW to 12kW.

1. The booster may be converted to a 12kW booster if required.
2. Follow instructions below:

21kW to 12kW Booster Conversion

- | | |
|----|--|
| 1 | Disconnect all power from the unit. |
| 2 | Remove the booster cover. |
| 3 | Remove the jumper wires from the 9kW element. |
| 4 | Connect a jumper wire between 73 on the 6kW elements. |
| 5 | Remove wire #74 from the 9kw element. |
| 6 | Reconnect wire #74 to the bottom left 6kW element. |
| 7 | Double-check all wiring. |
| 8 | Replace the booster cover. |
| 9 | Replace data plate with new stowed in control cabinet. |
| 10 | Conversion is complete. |

21kW Booster

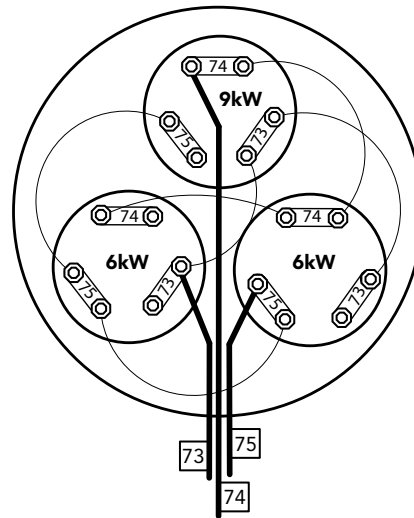

#73 and #75 FROM CONTACTOR
#74 DIRECT FROM CABINET

12kW Booster

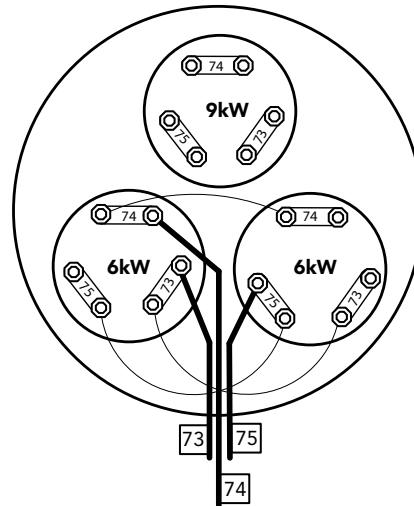

#73 and #75 FROM CONTACTOR
#74 DIRECT FROM CABINET

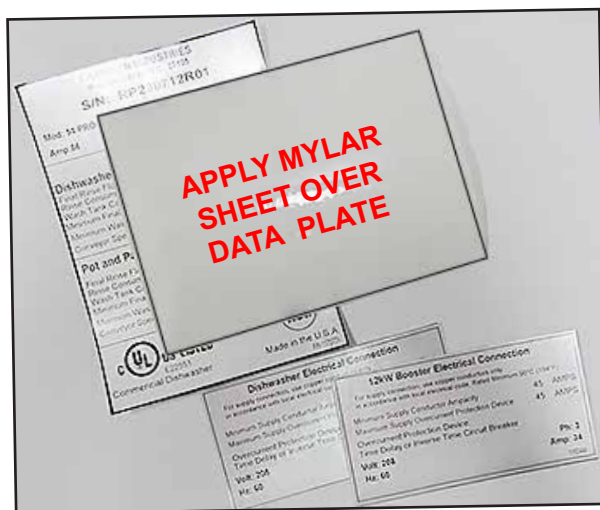

Fig. 28 - Replacement data plate package

Check Motor Rotation

1. All motor are phased the same at the factory.
2. Rotation arrows are affixed to the motors, (Fig. 29).
3. A rotation arrow is located at drive assembly sensor, (Fig. 30).
4. Fig. 31 shows the tolerances and adjustments for the drive sensor.

Reverse 1L1 AND 1L2 at the machine power terminal block in the control cabinet to reverse all motor rotations.



Fig. 29 - Motor rotation arrow

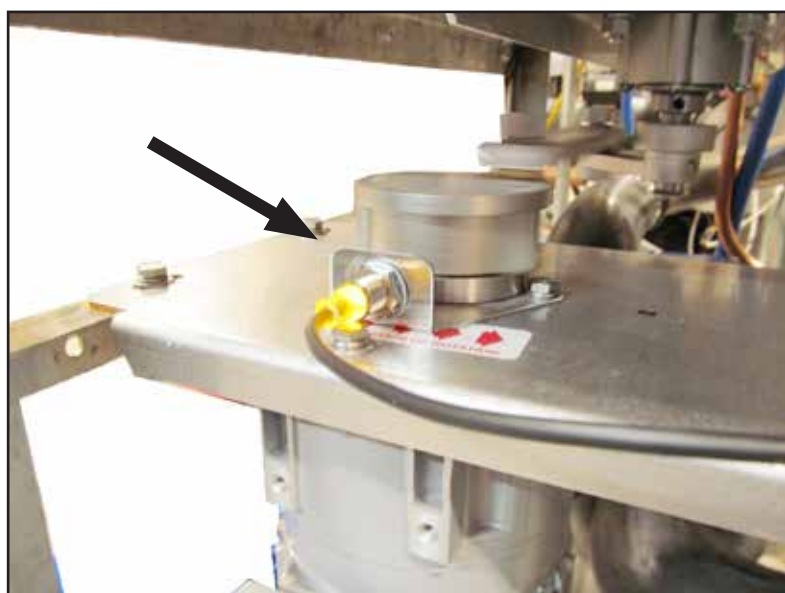

Fig. 30 - Drive assembly sensor

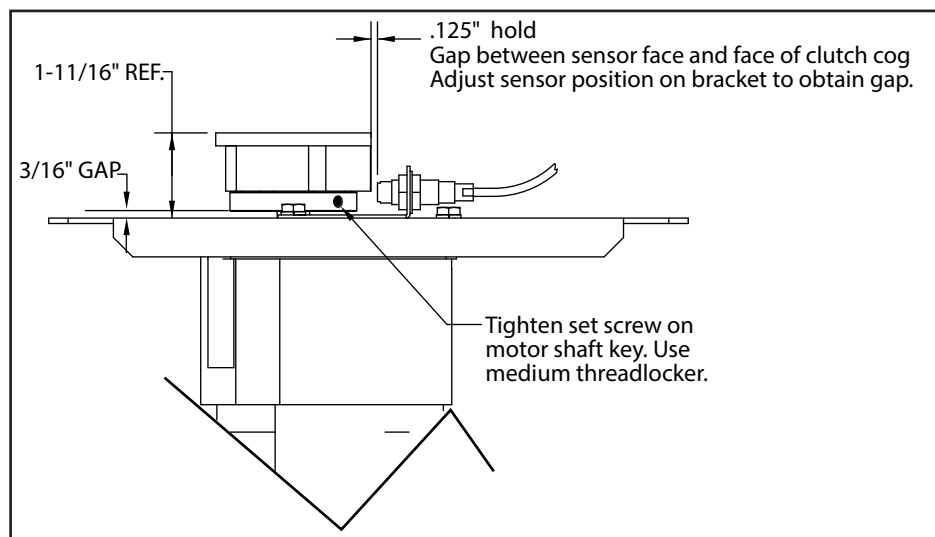

Fig. 31 - Drive assembly sensor adjustments

**This page was
intentionally
left blank.**

**This page was
intentionally
left blank.**

APPENDIX A:

Directlink Connectivity

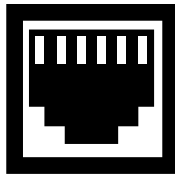

DIRECT LINK CONNECTIVITY

Directlink is the Champion remote access solution to monitor and support warewashing machine performance via the internet. Directlink employs the StrideLinx Cloud Application for secure communication and data logging.

- **Directlink Basic Maintenance Support** monitors dishwasher operation. Champion service technicians can troubleshoot machine problems and implement solutions.
Access is restricted to Champion service.
- **Directlink Plus Maintenance Support with Cloud Data Recording** monitors operation in real time delivering live data, historical temperature data and machine status indicators.
Access is granted to the end-user and Champion service.

Components

1. Champion supplies a Stridelinx router, internal RJ45 ethernet cables and a RJ45 ethernet port. Components are located in the top-mounted main control cabinet (Figs. 1, 2, 3, and 4).
2. The end-user supplies an RJ45 ethernet cable, network server and laptop or PC.

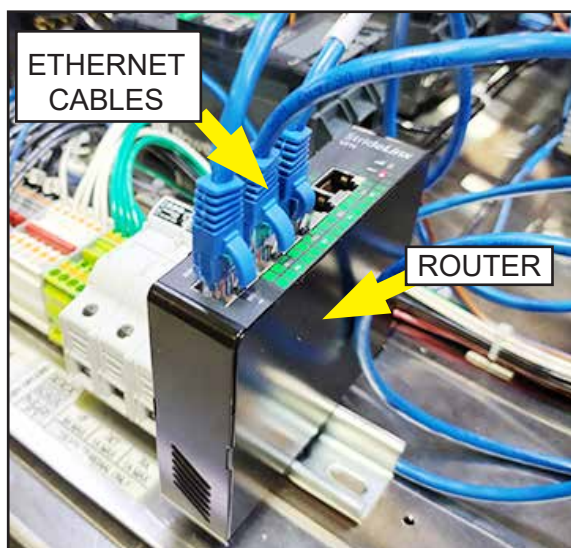

Fig. 1 - Router with ethernet cables

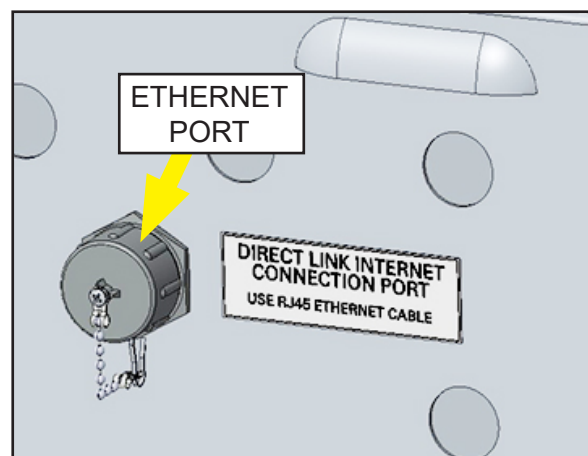

Fig. 2 - Ethernet port (viewed from rear of control cabinet)



Fig. 4 -
Ethernet port - Champion RJ45 from router
(viewed from inside rear of control cabinet)



Fig. 3 - Ethernet port (cap off)

DIRECTLINK OPERATION



NOTE:

THE END-USER MUST SUPPLY ACTIVE CAT5 or CAT6 DATA CABLE WITH ACCESS TO THE INTERNET. The Champion router communicates through the internet via Network Address Translation, (NAT). Champion does not support connectivity via WiFi or Cellular networks at this time.



WARNING:

The router is configured at the factory for communication back to Champion Industries. **DO NOT** attempt to reconfigure the router via the USB port as this may prevent the router from communicating with the machine or factory.



WARNING:

NEVER RESET THE ROUTER USING THE ON-BOARD RESET BUTTON! This will remove the router from the network; reset to factory default settings; and require router replacement.

Directlink Basic and Directlink Plus Set-up

STEP 1:

Connect the end-user Ethernet Cable to the Champion Ethernet Port. The port is located on the back of the top-mounted main control cabinet. DO NOT CONNECT THE END-USER ETHERNET CABLE DIRECTLY INTO THE ROUTER. A CABLE FROM THE ROUTER TO THE PORT WAS INSTALLED AT THE FACTORY.

STEP 2:

Once the end-user ethernet cable connection is established, contact the Champion Service Department to ensure the router is active on the Stridelinx Network.



NOTE:

Refer to the Stridelinx Troubleshooting Guide on page 29 if a network connection cannot be established.

Directlink Basic set-up is complete. The end-user is online and Champion has access to the warewasher for technical support and software updates

Directlink Plus set-up continues with Step 3 on next page.

DIRECTLINK OPERATION (continued)

Directlink Plus Set-up (continued)

STEP 3:

Gather the names and email addresses of all end-users needing access to the Cloud Dashboard containing live and historical temperature data and machine status indicators.

- Email the user list to directconnect@championindustries.com
- Upon receipt, Champion will send an invitation asking users to create their unique logins and passwords to access the Cloud Dashboard for their machine, (Fig. 5 and Fig. 6).
- Ensure the organization's spam filter allows emails from stridelinx@automationdirect.com.



NOTE:

If a user does not receive an invitation after the user list is submitted, check user SPAM, TRASH, and JUNK email folders before contacting Champion.

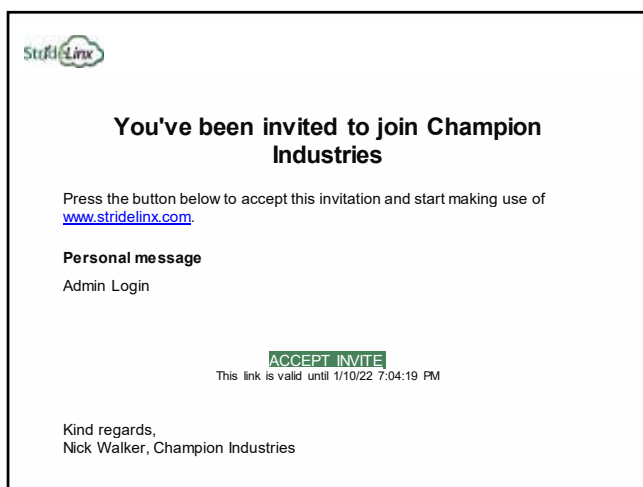

Fig. 5 - Dashboard invite

Fig. 6 - Account set-up

(Continued on next page.)

DIRECTLINK OPERATION (continued)

Directlink Plus Set-up (continued)

STEP 4:

To access your machine's dashboard, navigate to <https://www.stridelinx.com>.

- Enter your login credentials and click on the machine's icon, (Fig. 7).
- If your facility has multiple machines registered on Directlink then those machines will be visible as well.
- You should have access to the Directlink Dashboard now.



NOTE:

Machines can be viewed either as an Icon View or as a List View.

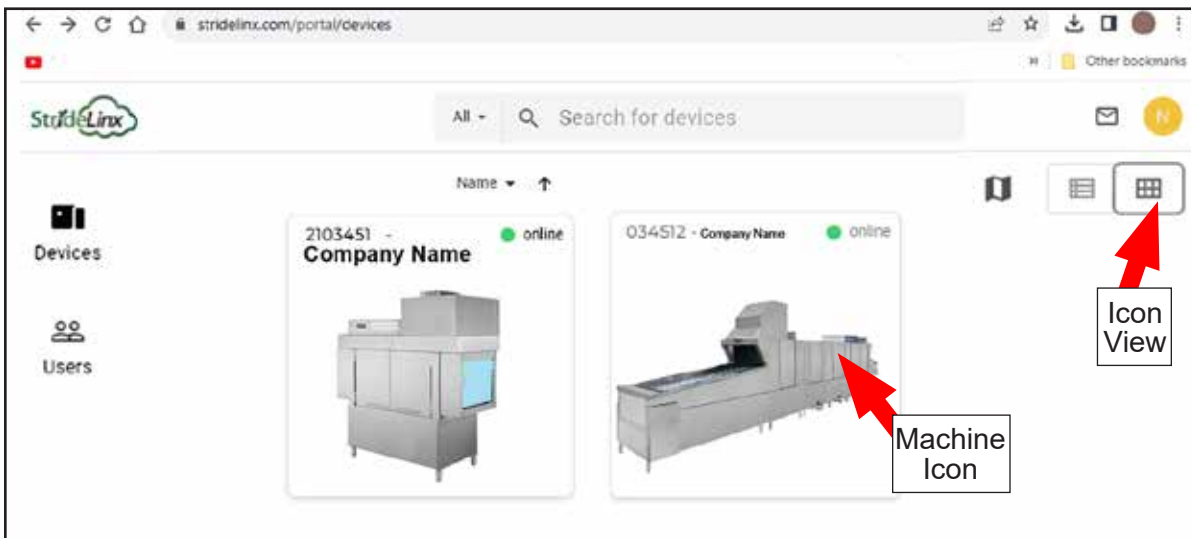

Fig. 7 - Click the machine icon to access your Directlink Dashboard.

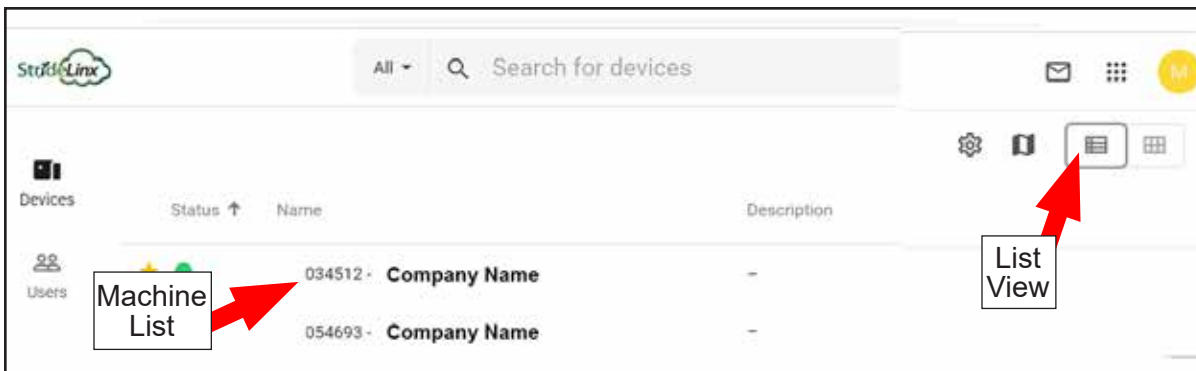

Fig. 8 - List View

(Continued on next page.)

Directlink Plus Machine Dashboard Operation

Figure 9 below is an example of a typical Directlink machine dashboard. From this panel, you can see: Real time machine status, real time temperatures, active machine faults and historical temperature data



Fig. 9 - Typical Directlink Machine Dashboard.

STEP 1:

To view historical data you first need to select the desired date range.

- Click the TODAY button in the upper right corner of the dashboard as shown in Fig. 9 above.
- The Time Range Selection Calendar will appear, Fig. 10.

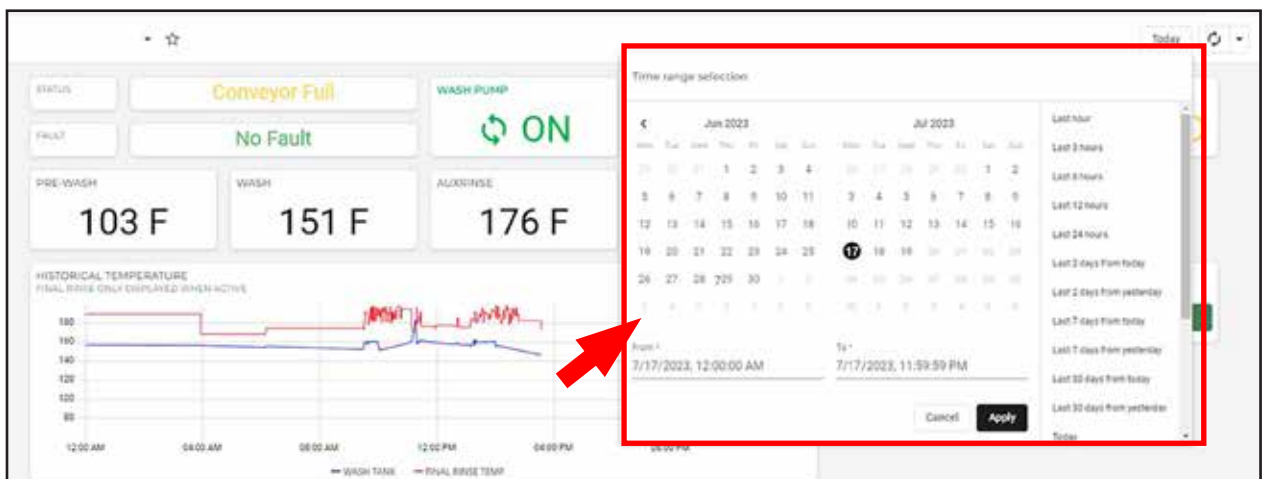

Fig. 10 - Time Range Selection Calendar

(Continued on next page.)

Appendix A:

Directlink Plus Machine Dashboard Operation (continued)

STEP 1:

There are two methods to select a Time Range for historical data:

- Select the preset times on the right side of the screen or
- Manually select a custom date range. 7/17/23 was selected in the Fig. 11 example below.

STEP 2:

Once the time range is selected, click Apply, (Fig. 11).

- The historical temperature graph will display the temperatures during the selected time period, (Fig. 9, page 25).
- Click the Download button in the Temperature Data Box, (Fig. 9 on page 25).
- The temperature data downloads from the cloud to a .CSV log file on your computer that can then be opened via Microsoft Excel or similar database software applications.

The screenshot displays a 'Time range selection' interface. On the left, a calendar for June and July 2023 is shown. The date 7/17/2023 is selected and highlighted. Below the calendar, the 'From' field is set to '7/17/2023, 12:00:00 AM' and the 'To' field is set to '7/17/2023, 11:59:59 PM'. At the bottom, there are 'Cancel' and 'Apply' buttons. On the right side, a 'Presets' menu is visible, listing various time ranges: 'Last hour', 'Last 3 hours', 'Last 6 hours', 'Last 12 hours', 'Last 24 hours', 'Last 2 days from today', 'Last 2 days from yesterday', 'Last 7 days from today', 'Last 7 days from yesterday', 'Last 30 days from today', 'Last 30 days from yesterday', and 'Today'. Red arrows point to the 'Presets' menu, the selected date 17, the 'From' and 'To' fields, and the 'Apply' button.

Fig.11 - Time Range Selection Calendar

(Continued on next page.)

When opening .CSV files in MS Excel, the Date/Time Stamp format may need modification to view the data correctly, (Fig.12).

	A	B	C	D
1	time	Final Rinse During Wash (F)	Wash Temperature (F)	
2	26:56.2		159	
3	26:46.5	179		
4	26:43.9	178		
5	26:42.3	177		
6	26:41.4	176		
7	26:40.6	175		
8	26:39.8	173		
9	26:39.5	172		
10	26:26.2		158	
11	25:56.2		160	

Fig. 12 - .CSV file download

STEP 3:

To reformat the Date/Time Stamp format

- Right click on Cell A to select the time column.
- Select Format Cells then Date and then select the Type form shown in Fig.13.
- Click OK to reformat the Time Column. It will look as shown in Fig.14 below.
- The time data is easier to read and analyze now.

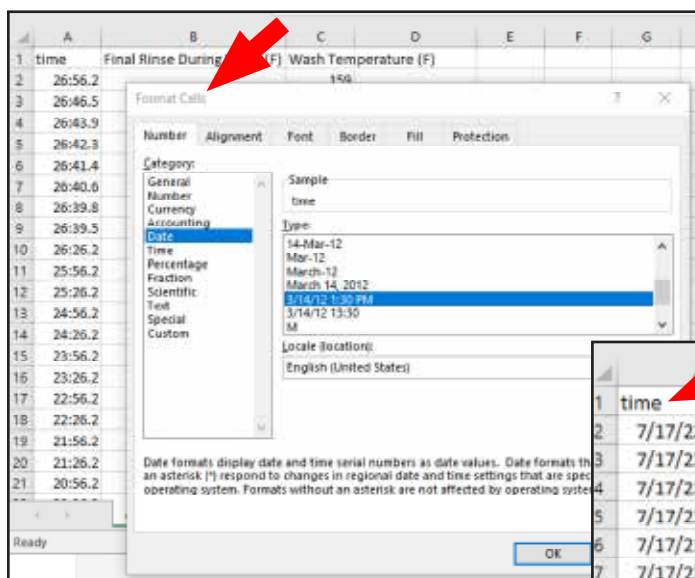

Fig. 13 - .Modify time column

	A	B	C	D
1	time	Final Rinse During Wash (F)	Wash Temperature (F)	
2	7/17/23 1:26 PM		159	
3	7/17/23 1:26 PM	179		
4	7/17/23 1:26 PM	178		
5	7/17/23 1:26 PM	177		
6	7/17/23 1:26 PM	176		
7	7/17/23 1:26 PM	175		
8	7/17/23 1:26 PM	173		
9	7/17/23 1:26 PM	172		
10	7/17/23 1:26 PM		158	
11	7/17/23 1:25 PM		160	
12	7/17/23 1:25 PM		160	

Fig. 14 - Reformatted time column.

STEP 4:

Close your browser to exit Directlink Plus.

This concludes Appendix A.

APPENDIX B:



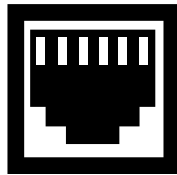





Stridelinx Troubleshooting Guide



STRIDELINX TROUBLESHOOTING GUIDE

The Stridelinx router is located in the main control panel on top of the machine. Follow proper safety measures accessing the unit. Wait at least 2 minutes after applying power to the Stridelinx router to allow for the unit to finish booting and attempting to connect to the StrideLinx Cloud. After the unit finishes booting, determine the status of the **Activity (ACT) LED** and follow the troubleshooting guide below:



- (ACT)  Constant red
- (ACT)  Blinking red 1 pulse
- (ACT)  Blinking red 3 pulses
- (ACT)  Blinking red 4 pulses
- (ACT)  Blinking red 5 pulses
- (ACT)  Blinking blue 1 pulse
- (ACT)  Blinking blue 2 pulses
- (ACT)  Constant blue



STRIDELINX TROUBLESHOOTING GUIDE

(ACT) Constant red

Description

The StrideLinx router is **booting**, which usually takes ~2 minutes, or is **not registered**.

Solution

If the ACT LED remains constant red for longer than 2 minutes after power is applied to the machine, contact Champion for assistance.

(ACT) Blinking red 1 pulse

Description

The StrideLinx router is **unable to access the StrideLinx server**.

Solution

Make sure that the StrideLinx router has **internet access**:

- Check the connection by unplugging the Ethernet cable from the StrideLinx router's WAN (internet) port and plugging it into your computer. Turn off any other connections on your computer, like Wi-Fi.

If your computer had internet access in the test above, then the StrideLinx router may not be configured correctly for the internal network.

- the **WAN (internet) settings** are correct for internet access in the local network. Letting the StrideLinx router obtain an IP address automatically (DHCP) will be suitable for most situations. If you require the unit to be configured with a static IP address instead, be sure to always consult the local IT administrator for the correct network settings (IP address, network mask, default gateway, and DNS server).

Note: If a static IP address is required, it will need to be provided to Champion for the Stridelinx router to be configured properly. The unit is default configured as DHCP.

- **proxy server** settings are correctly configured, if applicable.

Make sure that the StrideLinx router is allowed to reach the **StrideLinx Cloud**:

- Check with the local IT administrator that the company firewall is not blocking the StrideLinx router's attempts to reach the StrideLinx Cloud.

STRIDELINX TROUBLESHOOTING GUIDE

(ACT) Blinking red 3 pulses

Description

There is a **LAN/WAN conflict** in the StrideLinx router settings. In other words, the LAN (machine network) IP range and WAN (corporate network) IP range are the same or IP-technically considered to be a part of one another. This means the StrideLinx router cannot differentiate between the two and cannot reliably determine which way is "the internet".

Solution

Contact Champion for assistance.

(ACT) Blinking red 4 pulses

Description

The StrideLinx router **was removed** from the StrideLinx Cloud.

Solution

Contact Champion service for assistance.

(ACT) Blinking red 5 pulses

Description

The StrideLinx router is trying to register itself in a StrideLinx Cloud company, but there is still an **old registration** from the router listed in that StrideLinx Cloud company. This situation usually happens when someone has [factory reset](#) the StrideLinx router and immediately tries to register it again.

Solution

Contact Champion for assistance.



STRIDELINX TROUBLESHOOTING GUIDE

(ACT) **Blinking blue 1 pulse**

Description

The StrideLinx router is **connecting** to the StrideLinx Cloud.

Solution

If you keep seeing this LED status it means that the StrideLinx router is unable to reach the StrideLinx Cloud.

- Check with the local IT administrator that their company firewall is not blocking the StrideLinx router's attempt to connect to the StrideLinx Cloud.

(ACT) **Blinking blue 2 pulses**

Description

The StrideLinx router is **initiating a VPN connection** to the closest StrideLinx VPN server.

Solution

If you keep seeing this LED status it means that the StrideLinx router is unable to establish the VPN connection. Make sure that you:

- turn on [stealth mode](#), if applicable.
- check with the local IT administrator that their company firewall is not blocking the StrideLinx router's attempt to set up a VPN connection.



STRIDELINX TROUBLESHOOTING GUIDE

(ACT) [REDACTED] Constant blue

Description

The StrideLinx router has an **active VPN connection** to the StrideLinx Cloud.

Solution

If you see the StrideLinx router listed in your StrideLinx Cloud company, but it doesn't have an active VPN connection:

- **Hard refresh** the webpage (CTRL+F5 for Windows users).

If you do not see the StrideLinx router listed in your StrideLinx Cloud company:

- Check if you are currently looking in the **right company**. You can switch company by opening the account menu in the top right corner and selecting [Switch company].
- Check with the person who invited you to see if you have **access** to this StrideLinx router.

This concludes Appendix B.

APPENDIX C:

ION Water Conditioner



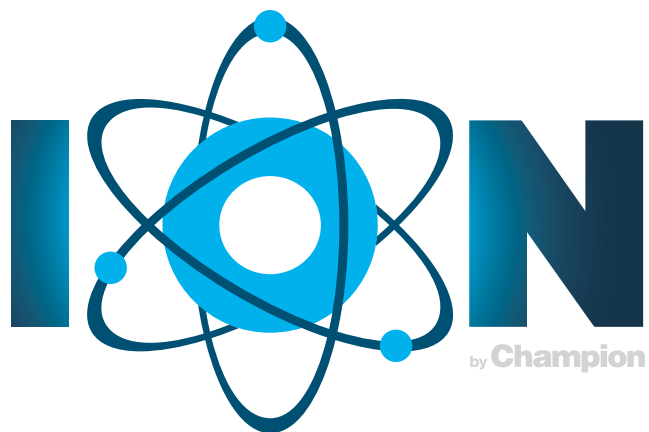

ION Water Conditioner

How ION Technology Works.....	2
Specifications	3
Water Flow Sizing	3
Plumbing Installation	4
Cleaning	7
Troubleshooting	10

How ION Technology Works

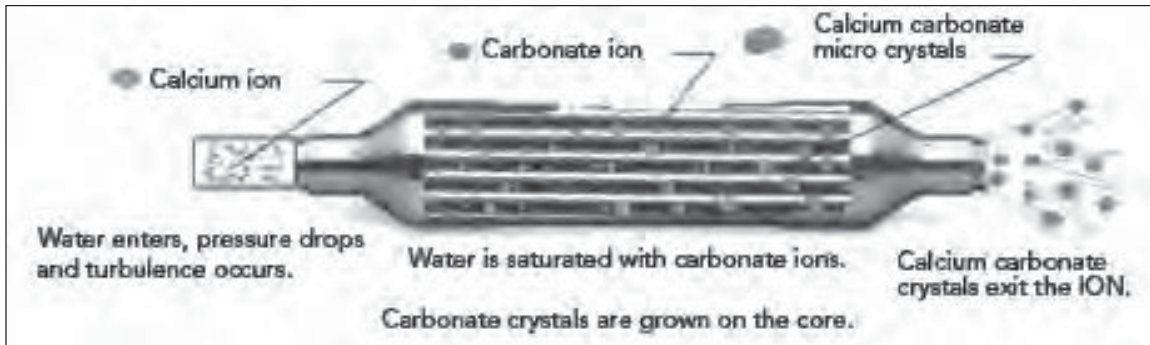

Fig. 1

First and foremost, the ION does not remove minerals from the water. The ION alters the structure of calcium carbonate in the water thereby changing its adhesion properties. The ION does not affect magnesium, chlorine or iron in the water.

Upon entering an ION, water experiences a pressure drop and turbulent flow. This causes dissolved carbon dioxide (CO_2) to become a gas in the water much like bubbles in carbonated water.

The pressure drop changes the chemical characteristics of the water producing a "saturated" condition with respect to calcium carbonate. This means the water in the ION is ready to precipitate or grow crystals of calcium carbonate (scale) on the ION core (see Fig. 1 above). The scale is changed from a hard crystal that adheres to surfaces to a soft paste that resists adhesion to metal surfaces.

The suspended calcium carbonate crystals precipitate out of the water and are discharged when the water drains from the machine.



Specifications

The housing material is Stainless Steel with 1/2" FPT on each end.

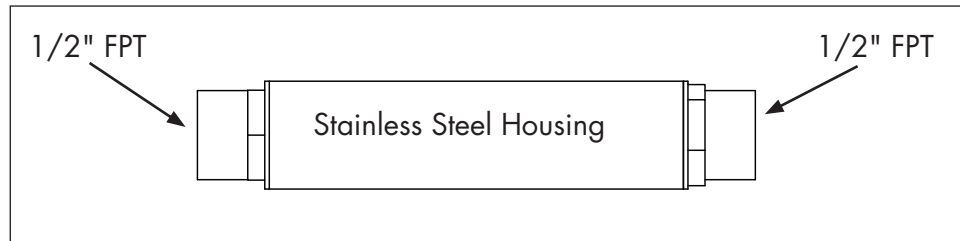

Fig.2

Water Flow Sizing

The size and GPM/LPM water flow range should be determined by the factory at the time the ION Water Conditioner is ordered. Please contact the Sales Department for an initial evaluation.

In the USA: 1 800 532-8591 or sales@championindustries.com

In Canada: 1 800 263-5798 or sales@moyerdiebellimited.com

ION Water Conditioner

Plumbing Installation



STOP:

The ION must be installed in a location that is accessible for its annual removal and cleaning.



CAUTION:

Plumbing connections must comply with all local plumbing, health and safety codes.

To prevent damage to ION water conditioner, only a qualified technician familiar with commercial dishwashers or a qualified plumber should perform the installation.

The plumbing lines must be thoroughly flushed to remove debris from the water supply line before connecting it to the dishwasher.

Damage caused by improper installation is not covered by the limited warranty.

Connection Details:

! MINIMUM 1/2" NPT HOT WATER SUPPLY LINE.

BOOSTER RISE °F	MINIMUM INCOMING TEMPERATURE	MINIMUM INCOMING SUPPLY FLOWING PRESSURE	MINIMUM/MAXIMUM OPERATING FLOWING PRESSURE
40° RISE	140°F / 60°C	45 PSI / 310 kPa	20/25 PSI / 138/172 kPa
70° RISE	110°F / 43°C	45 PSI / 310 kPa	20/25 PSI / 138/172 kPa
VHR and HR	110°F / 43°C	45 PSI / 310 kPa	20/25 PSI / 138/172 kPa

! MINIMUM 1/2" NPT COLD WATER SUPPLY LINE.

VHR and HR	55-75°F / 13-24°C	45 PSI / 310 kPa	20/25 PSI / 138/172 kPa
------------	-------------------	------------------	-------------------------

! INSTALL 1/2" SHUT-OFF VALVES AND UNIONS IN THE WATER SUPPLY LINE BEFORE AND AFTER THE ION FOR SERVICING.

! INSTALL THE ION BEFORE ANY FILTERS EXCEPT AN IRON (Fe) FILTER. INSTALL THE ION BEFORE DETERGENT AND RINSE-AID EQUIPMENT.

ION Water Conditioner

Fig. 3 below illustrates five sample piping configurations. In all of the samples, note that unions (A) and shut-off valves (B) are provided for the easy removal of the ION for servicing. Samples 1-3 illustrate pressurized piping systems; samples 4 and 5 illustrate non-pressurized systems. The ION operates efficiently in either direction; however, note that in non-pressurized systems, the ION must be installed in a vertical position. This ensures the ION is submerged at all times due to the direction of water flow as shown in sample 4). Sample 5 shows an alternate configuration for a non-pressurized system.

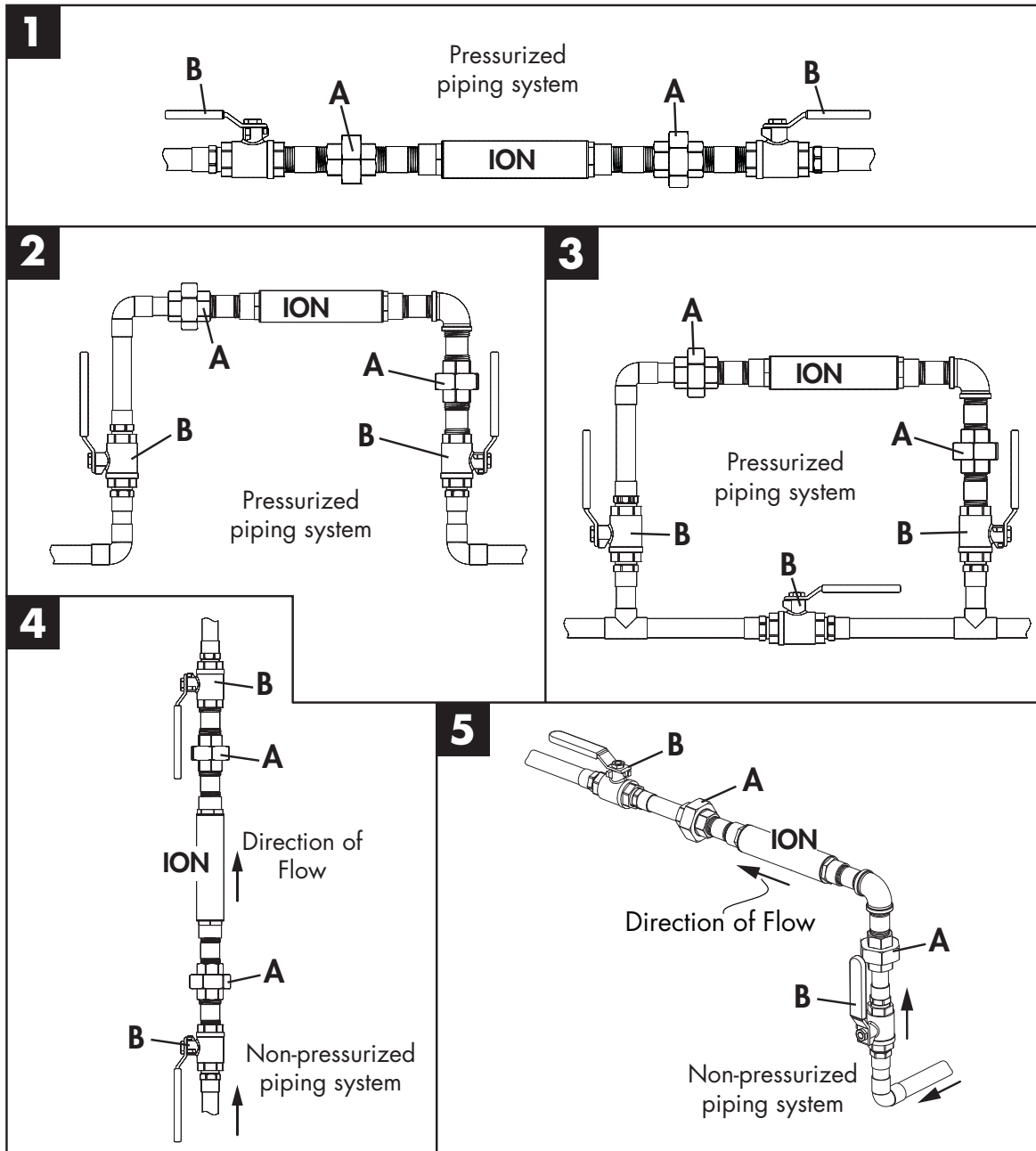

Fig. 3

Plumbing Installation (continued)



STOP:

Handle the core with extreme care during installation and cleaning. The ION conditioner core is extremely brittle and may shatter if the ION assembly or its core is dropped.

DROP DAMAGE IS NOT COVERED BY THE ION LIMITED WARRANTY.

It is highly recommended that the ION be installed in a new or clean dishwasher that is free from scale build-up and is not connected to a water softening system.

CONNECTING AN ION TO A MACHINE PREVIOUSLY CONNECTED TO A WATER SOFTENING SYSTEM OR CONTAINING SCALE BUILD-UP WILL CHANGE THE DESCALING PERFORMANCE OF THE ION FOR A LIMITED AMOUNT OF TIME.

1. Select an installation location in the water supply piping that is accessible for servicing. Refer to examples 1-5, in Fig. 3, on page 5 for suggested piping configurations.
2. Turn the main water supply off.
3. Drain the water line before cutting or disassembling the piping.
4. The ION may be installed in either direction.
5. Teflon tape may be used on the ION pipe connections.

NEVER USE PIPE THREAD COMPOUND ON THE ION PIPE CONNECTIONS.

6. Hand-tighten the ION threaded connections and then finish tightening with a wrench.
7. After installation, open the water supply valve(s) and slowly allow air to escape.
8. Run the water for approximately thirty seconds to ensure the ION is full of water.
9. The installation is complete.

ION Water Conditioner

Cleaning

**STOP:**

The ION METAL CORE is extremely brittle and will break if the ION or the core is dropped. Handle the core with extreme care during removal and cleaning.

Drop damage is not covered by the limited warranty.

**NOTE:**

The ION will release existing scale; therefore, if there is a heavy scale build-up in the machine or in the plumbing, it may be necessary to clean the bottom of the machine more frequently until the excess scale is eliminated. In addition, incoming water may appear cloudy but will clear over time. These are normal conditions.

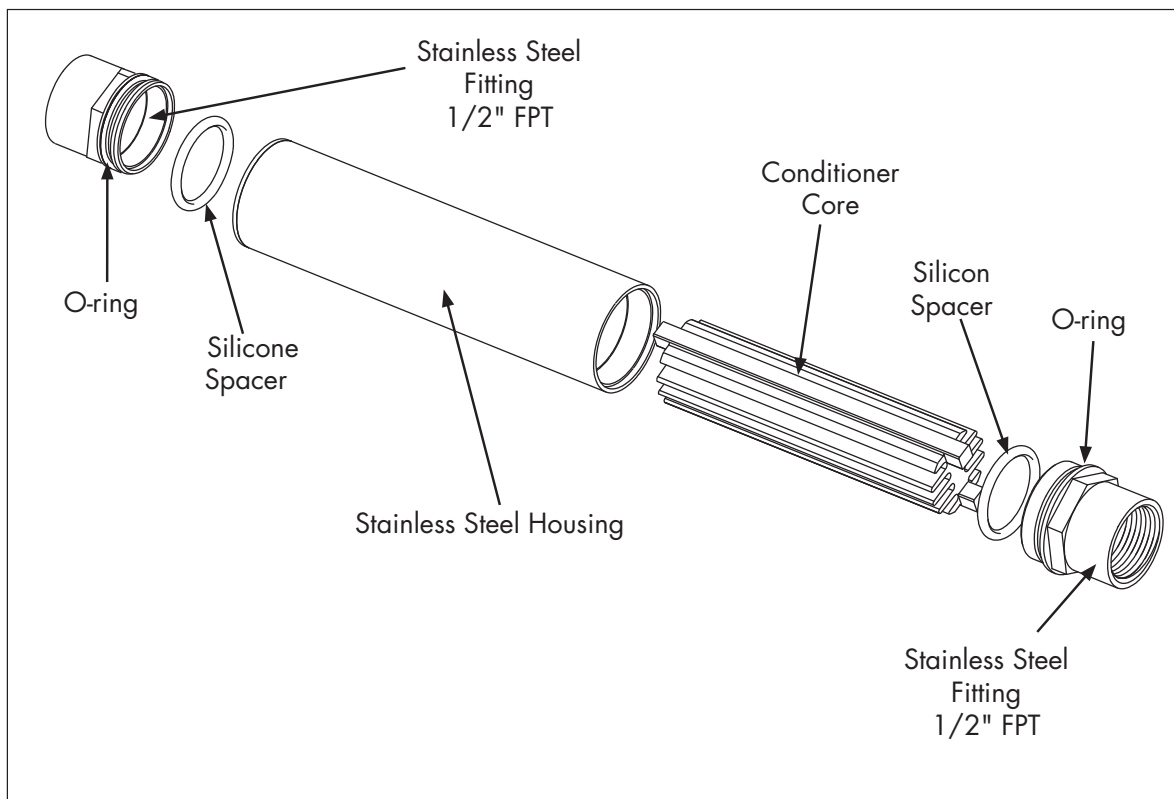

Fig.4

continued on next page

Appendix C:

ION Water Conditioner

Cleaning (continued)

1. There is no standard cleaning interval for the ION water conditioning unit because water chemistry varies from region to region; however, annual cleaning is the recommended minimum requirement.
2. If your region has unusually hard water, then check the core for deposits that may interfere with its operation. Iron deposits appear red in color, in which case, add an iron filter BEFORE the ION on the incoming water supply line. Figure 5 below illustrates how deposits may appear on the ION core.

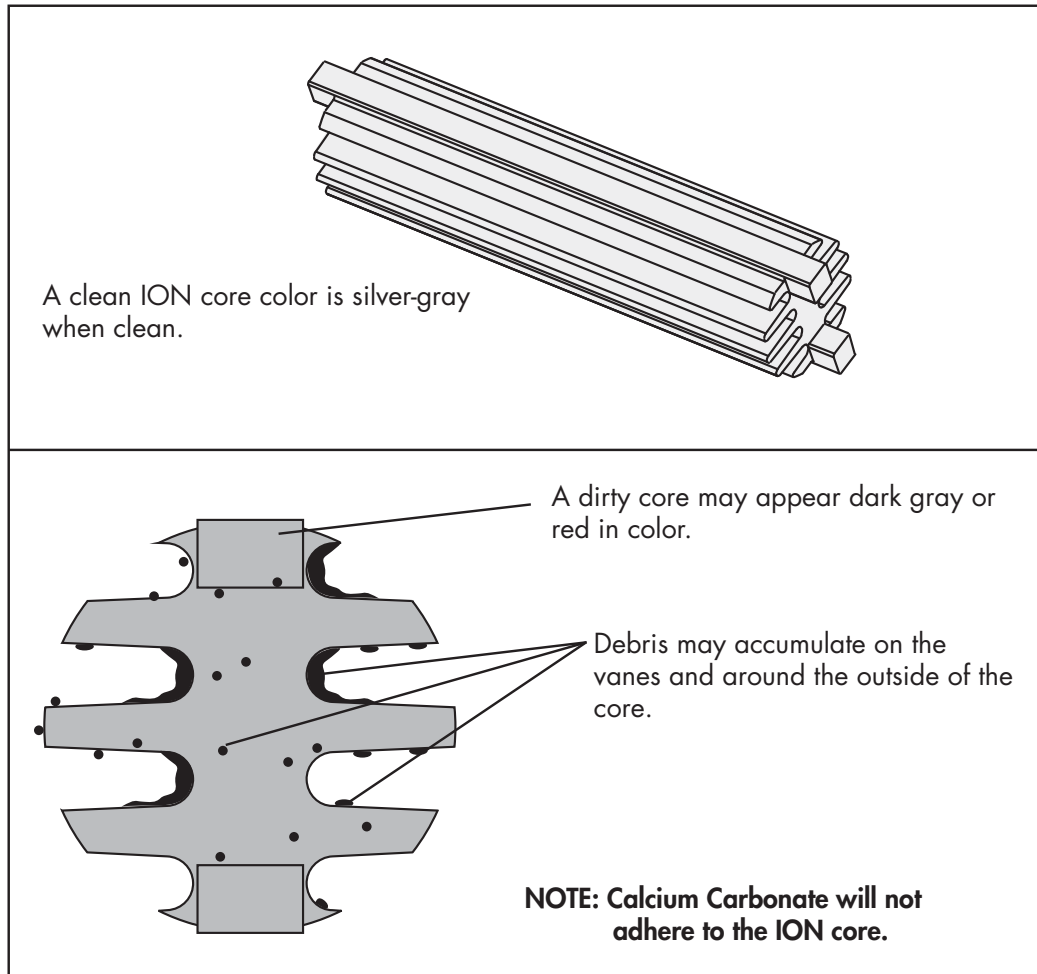

Fig. 5

3. To remove the ION, close the hot water supply and the ION isolation valves.
4. Carefully, remove the unit from the water line. Be careful not to drop the unit.
5. The housing, with the core removed, can be reinstalled in the water line to allow the operation of the dishwasher while the core is being cleaned.

ION Water Conditioner

Cleaning

6. Refer to Fig.4, page 7. Disassemble the unit, and remove core from the housing. Handle with care, the core is brittle and will fracture if dropped.
7. Soak the core in nickel-safe ice machine cleaner, CLR®, Lime-A-Way® or an equivalent cleaner making sure to follow all of the chemical manufacturer' s safety precautions. Do not soak the core longer than necessary.

**STOP:**

**NEVER CLEAN THE CORE WITH A METALLIC BRISTLE BRUSH
TO PREVENT PERMANENT DAMAGE TO THE ION**

8. Soak the core for approximately fifteen minutes to loosen any deposits. Safely remove the core from the cleaning solution and rinse thoroughly with water. If necessary, use a **nylon bristle brush** to clean any remaining deposits from the core. The core will have a silvery gray finish after cleaning is complete.
9. Repeat Step 7 and 8 until the core is clean. Note:The cleaning solution may turn black during the soaking operation. This is a normal condition indicating the cleaner is working.
10. Flush the core with clean fresh water to remove any cleaner residue.
11. Refer to Fig.4 on page 7 to reassemble the unit.
12. Place the clean core into the outer housing. If equipped, make sure the O-rings and spacers are in place and seated properly.
13. Reinstall the ION unit into the water supply line.
14. Slowly turn the water shut-off valves On.
15. Cleaning is complete.

ION Water Conditioner

Troubleshooting

PROBLEM	CAUSE	SOLUTION
Low or no water flow.	Water valve(s) closed. Incoming water pressure low. Clogged line strainer. Restricted ION core. Wrong ION installed.	Open valve. Increase flowing PSI to 20-22 PSI. Clean or replace strainer. Clean core (see pgs. 7-9). Contact service agent.
Water entering the machine is cloudy.	Water softening system is installed in water supply. Water softening system was previously installed but now disconnected.	Disconnect water softener. There may be water softener deposits in line. Continue to use ION until cloudiness dissipates.
Heavy scale deposits in the bottom of the dishwasher following ION installation.	The ION is removing scale deposits from previous dishwasher operations.	Thoroughly clean bottom of dishwasher and increase scheduled cleanings. Heavy deposits will decrease as the ION operates.
Deposits begin to appear on previously clean dishwasher.	Deposits are not calcium carbonate. ION core needs cleaning. ION improperly assembled.	Contact service agent. Following all safety procedures and wearing protective clothing and eye protection, test the deposit. Calcium carbonate fizzes when tested with an acid cleaner. Clean ION core (see pgs. 7-9). Increase scheduled cleaning. The minimum cleaning interval is once a year. Make sure silicon spacers are properly installed.
ION core is broken.	Core will shatter if the ION assembly or the core is dropped.	Replace the ION assembly. Handle the core with extreme care in the future.

This concludes Appendix C.

