

Champion[®]

The Dishwashing Machine Specialists

*For machines beginning with
serial no. D1848 thru D3693.*

Technical Manual

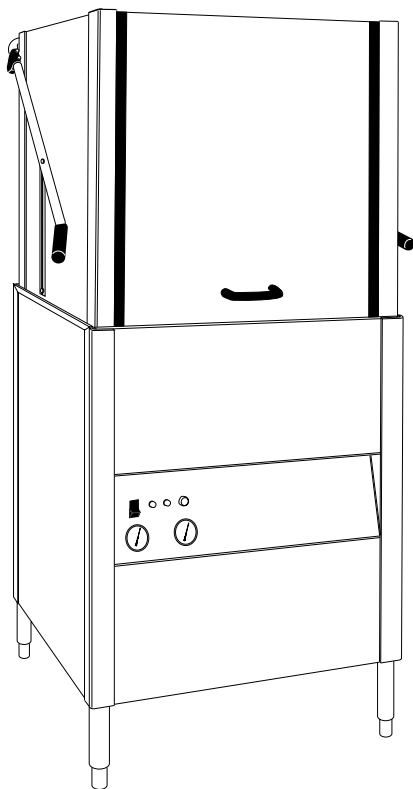

Door-Type Extended Hood Dishwasher

Model

D-HBTM4, D-HBTCM4
High Temperature
Extended Hood
with Built-in Booster

D-H1TM4, D-H1TCM4
High Temperature
Extended Hood
without Built-in Booster

Machine Serial No.

February, 2003

Manual P/N **113138** Rev. C

P. O. Box 4149
Winston-Salem, North Carolina 27115-4149
336/661-1556 Fax: 336/661-1660

2674 N. Service Road
Jordan Station, Ontario, Canada L0R 1S0
905/562-4195 Fax: 905/562-4618

www.championindustries.com

Complete the information below so it will be available for quick reference.

Model Number _____ Serial Number _____

Voltage and Phase _____

Champion Parts Distributor _____ Phone _____
(if applicable)

Champion Service Agency _____ Phone _____

Champion Service:

Champion, US

Phone: 1(336) 661-1556

1(800) 858-4477

Fax: 1(336) 661-1660

Champion, Canada

Phone: 1(905) 562-4195

1(800) 263-5798

Fax: 1(905) 562-4618

Note: When calling to order parts, be sure to have the model number, serial number, voltage and phase of your machine, along with your customer account number.

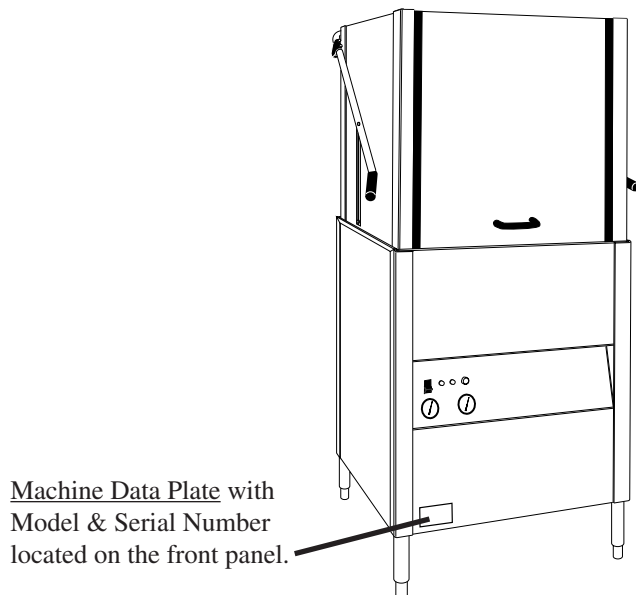

Machine Data Plate with Model & Serial Number located on the front panel.

Revision History

Revision Date	Revised Pages	Serial Number Effectivity	Comments
04/01/01	All		Issue of New Manual and Service Parts List
08/28/01		D2964	First S/N with electrical drain valve 113315 and timer 113314
08/28/01	47	—	Added P/N 900830 Drain Valve Kit for machines D1848 thru D2963
01/03/02	55	D3291	Change vacuum breaker 3/4" P/N 104429 to 113222
01/03/02	40, 41		Added straight track assembly
05/20/02	55		Added 900837 Kit* Repair, 3/4" vacuum breaker
12/18/02	63	D3857	Inserted timer control board kit P/N 900911 to replace 112676.
2/5/03	49, 61	—	Replaced P/N 108391 with 113622 .
2/5/03	59	D3950	Replaced P/N 111143 with 113248 .
2/5/03	63	—	Replaced Furnace (Siemens) overloads with Telemecanique (Square D) overloads.

CONTENTS

LIMITED WARRANTY	iv
INTRODUCTION	1
Model Number	2
Standard Equipment	2
Options	2
Electrical Power Requirements	3
INSTALLATION	4
Unpack the Dishwasher	4
Electrical Connections	5
Plumbing Connections	7
Water Connections	7
Drain Connections	8
Chemical Connections	9
INITIAL START-UP	11
OPERATION SUMMARY	17
CLEANING	18
Cleaning Schedule	18
Deliming Process	19
TROUBLESHOOTING	20
BASIC SERVICE	22
REPLACEMENT PARTS	31
ELECTRICAL SCHEMATIC	67

LIST OF FIGURES

Figure 1 – Remove Front Panel.....	4
Figure 2 – Electrical Connection Location	5
Figure 3 – Hinged Control Panel.....	6
Figure 4 – Main Terminal Block	6
Figure 5 – Hot Water Connection (D-HBT Only)	7
Figure 6 – Hot Water Connection (D-HIT Only)	7
Figure 7 – Chemical Dispenser Signal Terminal Block	9
Figure 8 – Chemical Signal Connection Points	9
Figure 9 – Detergent Probe Injection Points, 1/2"	10

LIST OF FIGURES (cont.)

Figure 10 – Rinse Aid Injection Point (Top of Dishwasher) 10

Figure 11 – Fuses 23

Figure 12 – Motor Overload 23

Figure 13 – Solid State Control Board 26

Figure 14 – Float Switch 27

Figure 15 – Float Switch Troubleshooting Chart 27

Figure 16 – Heater Element Wiring 28

Figure 17 – Pump Motor Wiring Diagrams 29

Figure 18 – Pump Seal Replacement 30

Figure 19 – Panels 32

Figure 20 – Doors, Guides, & Stops (D-HBT, D-H1T) 34

Figure 21 – Doors, Guides & Stops (Corner Model Only) (D-HBTC/DH1TC) 36

Figure 22 – Door Handle, Spring Assembly and Safety Switch 38

Figure 23A – Straight Track Assembly 40

Figure 23B – Corner Track Assembly 40

Figure 24 – Wash/Rinse Spray Piping 42

Figure 25 – Wash/Rinse Spray Arms 44

Figure 26 – Drain Assembly and Scrap Screens 46

Figure 27 – Wash Tank Heat and Thermostats 48

Figure 28 – Electric Booster and Thermostats 50

Figure 29 – Lower Fill Piping Assembly (D-HBT Only) 52

Figure 30 – Upper Fill Piping Assembly (D-HBT/D-H1T) 54

Figure 31 – Lower Fill Piping Assembly (D-H1T Only) 56

Figure 32 – Pump Assembly 58

Figure 33 – Control Panel and Gauges 60

Figure 34 – Control Cabinet 62

Figure 35 – Dishracks and PRV 64

APPENDIXES

Appendix A – Drain Valve/Timer Circuit 66

ELECTRICAL SCHEMATICS

B701648/F (D-HBT, D-H1T Steam/Electric 1 & 3 Phase)

LIMITED WARRANTY

Champion Industries, Inc., P.O. Box 4149, Winston-Salem, North Carolina 27115, and P.O. Box 301, 2674 North Service Road, Jordan Station, Ontario, Canada L0R 1S0, warrants machines, and parts, as set out below.

Warranty of Machines: Champion warrants all new machines of its manufacture bearing the name “Champion” and installed within the United States and Canada to be free from defects in material and workmanship for a period of one (1) year after the date of installation or fifteen (15) months after the date of shipment by Champion, whichever occurs first. [See below for special provisions relating to Model Series CG] The warranty registration card must be returned to Champion within ten (10) days after installation. If warranty card is not returned to Champion within such period, the warranty will expire after one year from the date of shipment.

Champion will not assume any responsibility for extra costs for installation in any area where there are jurisdictional problems with local trades or unions.

If a defect in workmanship or material is found to exist within the warranty period, Champion at its election, will either repair or replace the defective machine or accept return of the machine for full credit; provided, however, as to Model Series CG, Champion’s obligation with respect to labor associated with any repairs shall end (a) 120 days after shipment, or (b) 90 days after installation, whichever occurs first. In the event that Champion elects to repair, the labor and work to be performed in connection with the warranty shall be done during regular working hours by a Champion authorized service technician. Defective parts become the property of Champion. Use of replacement parts not authorized by Champion will relieve Champion of all further liability in connection with its warranty. In no event will Champion’s warranty obligation exceed Champion’s charge for the machine. The following are not covered by Champion’s warranty:

- a. Lighting of gas pilots or burners.
- b. Cleaning of gas lines.
- c. Replacement of fuses or resetting of overload breakers.
- d. Adjustment of thermostats.
- e. Adjustment of clutches.
- f. Opening or closing of utility supply valves or switching of electrical supply current.
- g. Cleaning of valves, strainers, screens, nozzles, or spray pipes.
- h. Performance of regular maintenance and cleaning as outlined in operator’s guide.
- i. Damages resulting from water conditions, accidents, alterations, improper use, abuse, tampering, improper installation, or failure to follow maintenance and operation procedures.

Examples of the defects not covered by warranty include, but are not limited to: (1) Damage to the exterior or interior finish as a result of the above, (2) Use with utility service other than that designated on the rating plate, (3) Improper connection to utility service, (4) Inadequate or excessive water pressure, (5) Corrosion from chemicals dispensed in excess of recommended concentrations, (6) Failure of electrical components due to connection of chemical dispensing equipment installed by others, (7) Leaks or damage resulting from such leaks caused by the installer, including those at machine table connections or by connection of chemical dispensing equipment installed by others, (8) Failure to comply with local building codes, (9) Damage caused by labor dispute.

Warranty of Parts: Champion warrants all new machine parts produced or authorized by Champion to be free from defects in material and workmanship for a period of 90 days from date of invoice. If any defect in material and workmanship is found to exist within the warranty period Champion will replace the defective part without charge.

DISCLAIMER OF WARRANTIES AND LIMITATIONS OF LIABILITY. CHAMPION’S WARRANTY IS ONLY TO THE EXTENT REFLECTED ABOVE. CHAMPION INDUSTRIES, INC. MAKES NO OTHER WARRANTIES, EXPRESS OR IMPLIED, INCLUDING, BUT NOT LIMITED, TO ANY WARRANTY OF MERCHANTABILITY, OR FITNESS OF PURPOSE. CHAMPION SHALL NOT BE LIABLE FOR INCIDENTAL OR CONSEQUENTIAL DAMAGES. THE REMEDIES SET OUT ABOVE ARE THE EXCLUSIVE REMEDIES FOR ANY DEFECTS FOUND TO EXIST IN CHAMPION DISHWASHING MACHINES AND CHAMPION PARTS, AND ALL OTHER REMEDIES ARE EXCLUDED, INCLUDING ANY LIABILITY FOR INCIDENTALS OR CONSEQUENTIAL DAMAGES.

Champion does not authorize any other person, including persons who deal in Champion dishwashing machines, to change this warranty or create any other obligation in connection with Champion Dishwashing Machines.

INTRODUCTION

Welcome to **Champion...**
and thank you for allowing us to take care of your dishwashing needs.

This manual covers the door-type dishwasher, Model D-HBT, D-H1T, D-HBTC, D-H1TC.
Your machine was completely assembled, inspected, and thoroughly tested at our factory before it was shipped to your installation site.

This manual contains:

- Installation Instructions
- Operation and Cleaning Instructions
- Troubleshooting Guide
- Basic Service Information
- Replacement Parts Lists
- Electrical Schematics

All information, illustrations and specifications contained in this manual are based upon the latest product information available at the time of publication. **Champion** constantly improves its products and reserves the right to make changes at any time or to change specifications or design without notice and without incurring any obligation.

For your protection, factory authorized parts should always be used for repairs.

Replacement parts may be ordered directly from your **Champion** authorized service agency. When ordering parts, please supply the model number, serial number, voltage, and phase of your machine, the part number, part descriptions and quantity.

Model Numbers

D-HBT, D-HBTC, D-H1T, D-H1TC

The D-HBT model is a high temperature (180°F/82°C rinse) sanitizing model with booster.

The D-H1T, D-H1TC models are high temperature (180°F/82°C rinse) sanitizing models.

Standard Equipment includes:

D-HBT, D-HBTC, D-H1T, DH1TC

- Automatic tank fill and start
- Adjustable cycle selector
- Built-in electric booster heater (D-HBT only)
- Specified as straight-through or corner models
- Electric tank heat
- Low-water tank heat protection
- 2-hp drip-proof pump motor
- Door safety switch
- Drain – electric & automatic
- Common utility connections
- Two dish racks (peg and flat bottom)
- Detergent/chemical connection provisions
- Stainless steel front and side panels
- 2" O.D. gravity drain connection
- Water pressure reducing valve (mounted)
- Interchangeable upper and lower spray arms

Options

- Electric booster (70°F/39°C temperature rise) heater for 110°F/43°C supply water
- Steam injector or steam coil tank heat (steam booster 40°F/23°C-70°F/39°C rise)

Accessories

Additional dishracks:

Dish rack (peg) P/N [101285](#)

Silverware rack (flat bottom) P/N [101273](#)

3/4" Pressure reducing valve (PRV) P/N [112387](#)

Electrical Power Requirements: Electric Heat/Electric Booster

Model	Voltage	Booster Rise (D-HBT Only)	Rated Amps	Minimum Supply Ckt. Conductor Ampacity	Maximum Overcurrent Protective Device
D-H1T	208/60/1	—	28 Amps	35 Amps	35 Amps
D-H1T	220/60/1	—	28 Amps	35 Amps	35 Amps
D-H1T	230/60/1	—	29 Amps	40 Amps	40 Amps
D-H1T	240/60/1	—	29 Amps	40 Amps	40 Amps
D-H1T	208/60/3	—	15 Amps	20 Amps	20 Amps
D-H1T	220/60/3	—	15 Amps	20 Amps	20 Amps
D-H1T	230/60/3	—	15 Amps	20 Amps	20 Amps
D-H1T	240/60/3	—	15 Amps	20 Amps	20 Amps
D-H1T	380/60/3	—	9 Amps	15 Amps	15 Amps
D-H1T	415/60/3	—	9 Amps	15 Amps	15 Amps
D-H1T	480/60/3	—	7 Amps	15 Amps	15 Amps
D-H1T	575/60/3	—	6 Amps	15 Amps	15 Amps
D-HBT	208/60/1	40°F/23°C	71 Amps	80 Amps	80 Amps
D-HBT	220/60/1	40°F/23°C	71 Amps	80 Amps	80 Amps
D-HBT	230/60/1	40°F/23°C	79 Amps	90 Amps	90 Amps
D-HBT	240/60/1	40°F/23°C	79 Amps	90 Amps	90 Amps
D-HBT	208/60/3	40°F/23°C	39 Amps	45 Amps	45 Amps
D-HBT	220/60/3	40°F/23°C	39 Amps	45 Amps	45 Amps
D-HBT	230/60/3	40°F/23°C	44 Amps	50 Amps	50 Amps
D-HBT	240/60/3	40°F/23°C	44 Amps	50 Amps	50 Amps
D-HBT	380/60/3	40°F/23°C	24 Amps	30 Amps	30 Amps
D-HBT	415/60/3	40°F/23°C	26 Amps	30 Amps	30 Amps
D-HBT	480/60/3	40°F/23°C	18 Amps	25 Amps	25 Amps
D-HBT	575/60/3	40°F/23°C	15 Amps	20 Amps	20 Amps
D-HBT	208/60/1	—	—	—	—
D-HBT	220/60/1	—	—	—	—
D-HBT	230/60/1	—	—	—	—
D-HBT	240/60/1	—	—	—	—
D-HBT	208/60/3	70°F/39°C	52 Amps	70 Amps	70 Amps
D-HBT	220/60/3	70°F/39°C	59 Amps	70 Amps	70 Amps
D-HBT	230/60/3	70°F/39°C	59 Amps	70 Amps	70 Amps
D-HBT	240/60/3	70°F/39°C	59 Amps	80 Amps	80 Amps
D-HBT	380/60/3	70°F/39°C	32 Amps	40 Amps	40 Amps
D-HBT	415/60/3	70°F/39°C	34 Amps	45 Amps	45 Amps
D-HBT	480/60/3	70°F/39°C	29 Amps	40 Amps	40 Amps
D-HBT	575/60/3	70°F/39°C	24 Amps	30 Amps	30 Amps

Electrical Power Requirements: Gas or Steam/Gas or Steam Booster

Model	Voltage	Booster Rise (D-HBT Only)	Rated Amps	Minimum Supply Ckt. Conductor Ampacity	Maximum Overcurrent Protective Device
D-H1T	208/60/1	—	15 Amps	20 Amps	20 Amps
D-H1T	220/60/1	—	15 Amps	20 Amps	20 Amps
D-H1T	230/60/1	—	14 Amps	20 Amps	20 Amps
D-H1T	240/60/1	—	14 Amps	20 Amps	20 Amps
D-H1T	208/60/3	—	7 Amps	15 Amps	15 Amps
D-H1T	220/60/3	—	7 Amps	15 Amps	15 Amps
D-H1T	230/60/3	—	7 Amps	15 Amps	15 Amps
D-H1T	240/60/3	—	7 Amps	15 Amps	15 Amps
D-H1T	380/60/3	—	5 Amps	15 Amps	15 Amps
D-H1T	415/60/3	—	4 Amps	15 Amps	15 Amps
D-H1T	480/60/3	—	4 Amps	15 Amps	15 Amps
D-H1T	575/60/3	—	3 Amps	15 Amps	15 Amps
D-HBT	208/60/1	40°F/23°C	15 Amps	20 Amps	20 Amps
D-HBT	220/60/1	40°F/23°C	15 Amps	20 Amps	20 Amps
D-HBT	230/60/1	40°F/23°C	14 Amps	20 Amps	20 Amps
D-HBT	240/60/1	40°F/23°C	14 Amps	20 Amps	20 Amps
D-HBT	208/60/3	40°F/23°C	7 Amps	15 Amps	15 Amps
D-HBT	220/60/3	40°F/23°C	7 Amps	15 Amps	15 Amps
D-HBT	230/60/3	40°F/23°C	7 Amps	15 Amps	15 Amps
D-HBT	240/60/3	40°F/23°C	7 Amps	15 Amps	15 Amps
D-HBT	380/60/3	40°F/23°C	5 Amps	15 Amps	15 Amps
D-HBT	415/60/3	40°F/23°C	4 Amps	15 Amps	15 Amps
D-HBT	480/60/3	40°F/23°C	4 Amps	15 Amps	15 Amps
D-HBT	575/60/3	40°F/23°C	3 Amps	15 Amps	15 Amps
D-HBT	208/60/1	—	—	—	—
D-HBT	220/60/1	—	—	—	—
D-HBT	230/60/1	—	—	—	—
D-HBT	240/60/1	—	—	—	—
D-HBT	208/60/3	70°F/39°C	7 Amps	15 Amps	15 Amps
D-HBT	220/60/3	70°F/39°C	7 Amps	15 Amps	15 Amps
D-HBT	230/60/3	70°F/39°C	7 Amps	15 Amps	15 Amps
D-HBT	240/60/3	70°F/39°C	7 Amps	15 Amps	15 Amps
D-HBT	380/60/3	70°F/39°C	5 Amps	15 Amps	15 Amps
D-HBT	415/60/3	70°F/39°C	4 Amps	15 Amps	15 Amps
D-HBT	480/60/3	70°F/39°C	4 Amps	15 Amps	15 Amps
D-HBT	575/60/3	70°F/39°C	3 Amps	15 Amps	15 Amps

INSTALLATION

Unpack the dishwasher

 **CAUTION:**
Care should be taken when lifting the machine to prevent damage.

 **NOTE:**
The installation of your machine must meet all applicable health and safety codes.

1. Immediately after unpacking the machine, inspect for any shipping damage. If damage is found, save the packing material and contact the carrier immediately.
2. Remove the dishwasher from the skid. Move the machine to its permanent location.
3. Level the machine (if required) by placing a level on the top of the machine and adjusting the feet. Level the machine front-to-back and side-to-side.
4. Remove the dishracks from the interior of the machine.
5. Refer to Fig. 1. Remove (2) screws that hold the front panel. Remove the front panel in preparation for service connections.

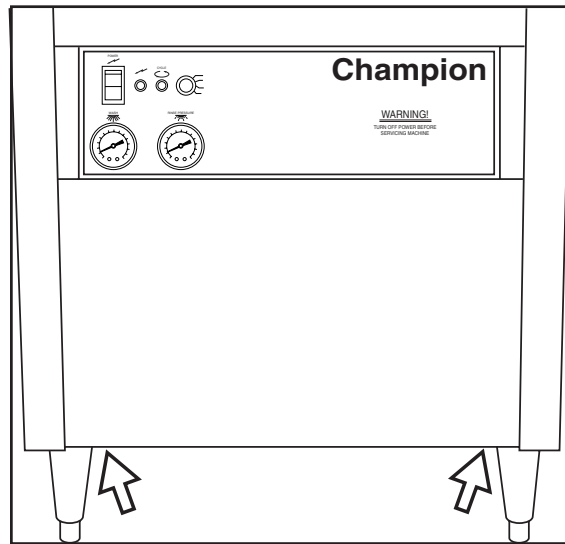



Figure 1
Remove Front Panel

INSTALLATION (Cont.)

Electrical Connections

WARNING:
 *Electrical and grounding connections must comply with all applicable Electrical Codes.*

WARNING:
 *When working on the dishwasher, disconnect the electric service and place a tag at the disconnect switch to indicate work is being done on that circuit.*

1. A qualified electrician must compare the electrical power supply with the machine electrical specifications before connecting to the incoming service through a fused disconnect switch.

Refer to Fig. 2

2. A knock-out is provided at the lower right rear corner (as viewed from the front) for the electrical service connection. A fused disconnect switch or circuit breaker (supplied by others) is required to protect the power supply circuit.

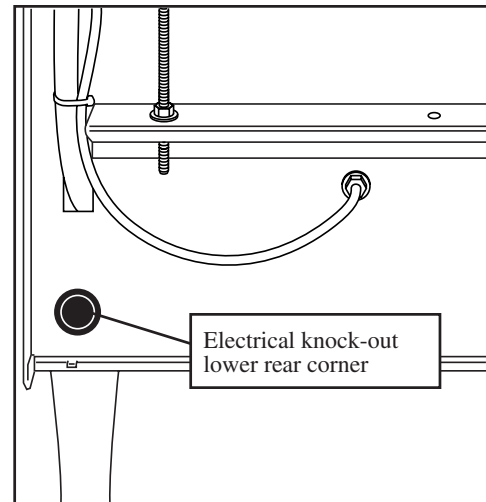

Figure 2
Electrical Connection Location

Electrical Connections (Cont.)

Refer to Fig. 3

3. Remove (2) lower screws from the front panel of the machine to expose the electrical controls. Remove (2) screws on the control panel support. Swing the hinged control panel forward.

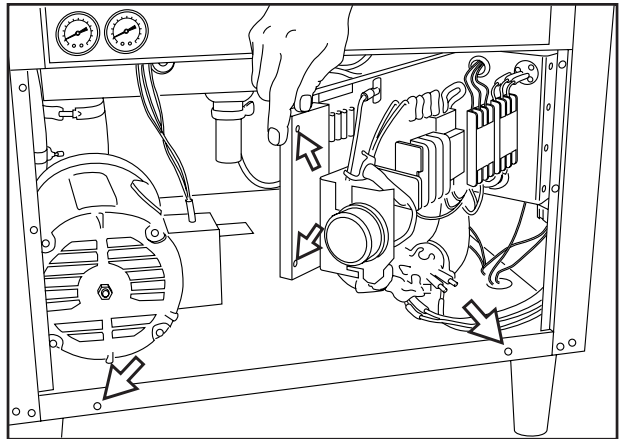

Figure 3
Hinged Control Panel

Refer to Fig. 4

4. Three phase or single phase incoming power wiring connections are made at the bottom of the machine's main terminal block. The main terminal block is located on the side of the front right post of the dishwasher.

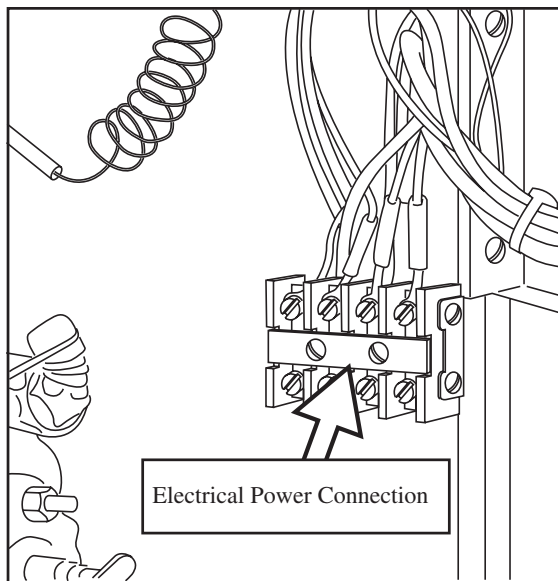

Figure 4
Main Terminal Block

INSTALLATION (Cont.)

Plumbing Connections

NOTE:

Plumbing connections must comply with all applicable sanitary and plumbing codes.

Water Connections

1. All D-HB/H1T series dishwashers require a single, hot water supply.

The hot water connection to all D-HB/H1T series dishwashers is 3/4" NPT.

The connection is made from underneath the dishwasher.

The following minimum water temperatures are recommended:

D-HBT with built-in 40° rise electric booster (Minimum 140°F/60°C)
(Min./Max. flow pressure
20-22 PSI/138-151.8 kPa)

D-HBT with built-in 70° rise electric booster (Minimum 110°F/43°C)
(Min./Max. flow pressure
20-22 PSI/138-151.8 kPa)

D-H1T without built-in booster (Minimum 180°F/70°C)
(Min./Max. flow pressure
20-22 PSI/138-151.8 kPa)

Refer to Figs. 5 and 6

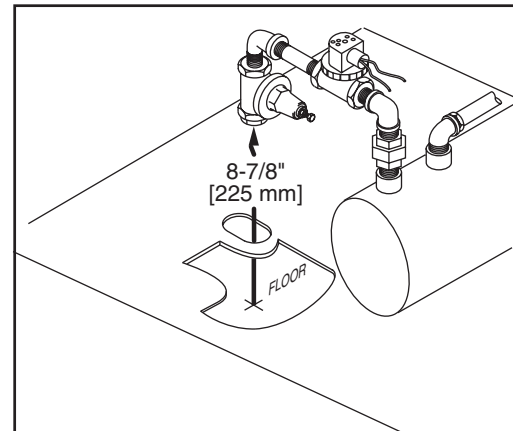

Figure 5
Hot Water Connection
3/4" NPT
(D-HBT Only)

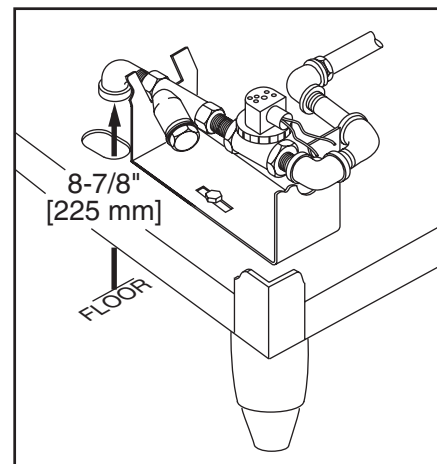

Figure 6
Hot Water Connection
3/4" NPT
(D-H1T Only)

Water Connections (Cont.)

2. A manual shut-off valve for steam and water (supplied by others) should be installed in the supply line to allow for servicing of the machine. The shut-off valve should be the same size or larger than the supply line.
3. Install a 3/4" pressure reducing valve (PRV) in the water supply line if flow pressure exceeds 20-22 PSI/138-151.8 kPa.

A PRV is standard equipment on Model D-HBT. A PRV is not standard equipment on Models D-H1T.

Drain Connections

1. All models are GRAVITY DRAIN machines equipped with a 2" O.D. hose connection point.
2. The maximum drain flow rate is 15 gallons/min-56.8 liters/min.
3. Drain height for all models must not exceed 8-7/8" (225mm) above floor level.
4. The drain connection is made to the dishwasher from underneath the machine through an access hole in the machine base.

Ventilation



NOTE:

Ventilation must comply with local sanitary and plumbing codes.



CAUTION:

Exhaust air should not be vented into a wall, ceiling, or concealed space of a building. Condensation can cause damage.

INSTALLATION (Cont.)

Chemical Connections

NOTE:
 Consult a qualified chemical supplier for your chemical needs. The detergent that you will need to use should be for automatic dishwashing machines.

Refer to Fig. 7

1. A chemical signal terminal block is supplied for chemical dispensing equipment.
2. The terminal block is located below the control panel fuse block.

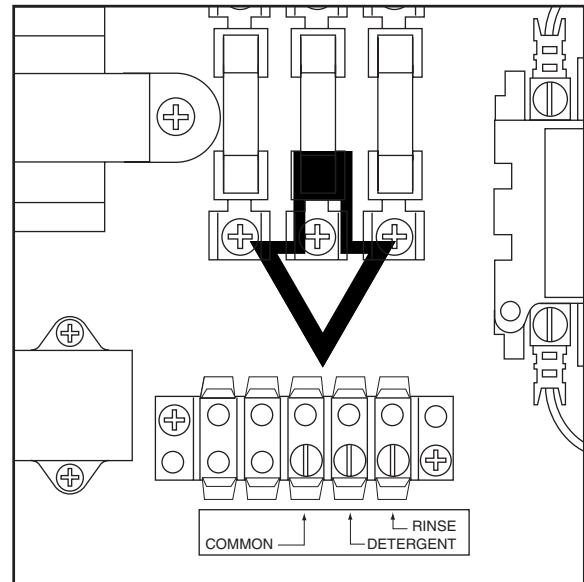

Figure 7
Chemical Dispenser
Signal
Terminal Block

Refer to Fig. 8

3. The detergent signal is limited to a maximum load of 1 Amp. Signal voltage is 115VAC.
4. The Rinse aid signal is limited to a maximum load of 1 Amp. Signal voltage is 115VAC.

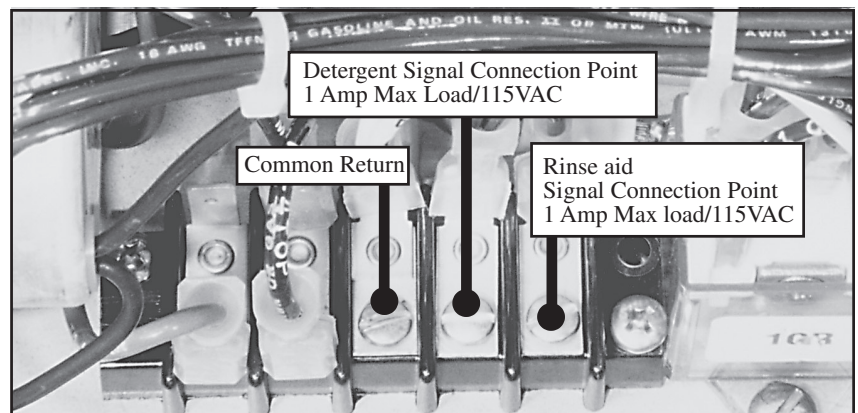

Figure 8
Chemical Signal
Connection Points

Chemical Connections (Cont.)

Refer to Fig. 9

- 5. A 1/2" detergent probe injection point is provided at the rear and left side of the dishwasher.
- 6. Detergent may be added manually if your dishwasher is not equipped with dispensing equipment. Consult your chemical supplier for recommended amounts.

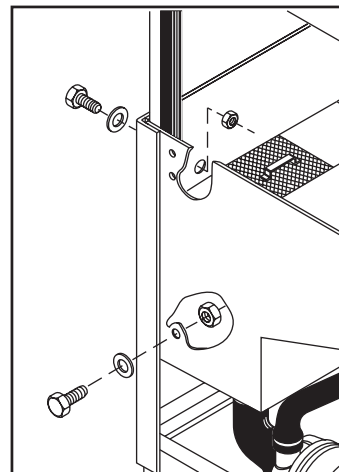

Figure 9
Detergent Probe
Injection Points, 1/2"

Refer to Fig. 10

7. **D-HBT, D-H1T**

A 1/4" NPT rinse aid injection point is provided in the final rinse manifold.

Use a liquid rinse aid.

The manifold is located on the top right side of the dishwasher.

Models D-HBT and D-H1T do not require sanitizer.

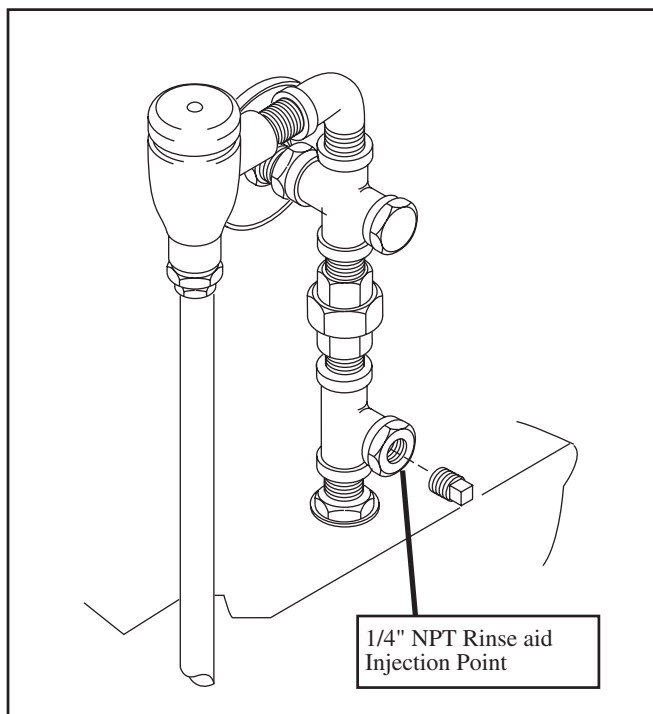

Figure 10
Rinse Aid Injection Point
(Top of Dishwasher)

INITIAL START-UP

Complete the Installation

After plumbing and electrical connections are made, follow the steps below to complete the installation of your dishwasher.

1. Remove the white protective covering from the exterior of the machine.
2. Remove any foreign material from inside the machine.
3. Make sure dishwasher power switch is off.
4. Turn main water supply on.
5. Turn main power on at the main power service disconnect switch.

1

Install the Scrap Screens

Install scrap screens.

Make sure that wash and rinse arms are installed correctly.

MAKE SURE DOORS ARE FULLY CLOSED.

2

The controls are located on the front of the dishwasher.

- A- On/Off power switch
- B- Power indicator Light
- C- In cycle light
- D- Wash cycle selector switch
- E- Wash water temperature gauge
- F- Final rinse pressure gauge

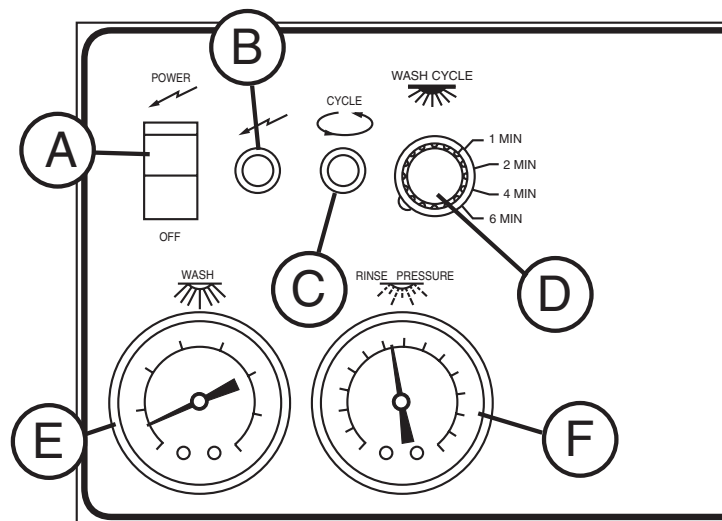

INITIAL START-UP (Cont.)

3

THE POWER SWITCH IS ON DURING INITIAL FILL.

Make sure the doors are fully closed.
Push the On/Off power switch to the UP position.

THE DISHWASHER FILLS AUTOMATICALLY.

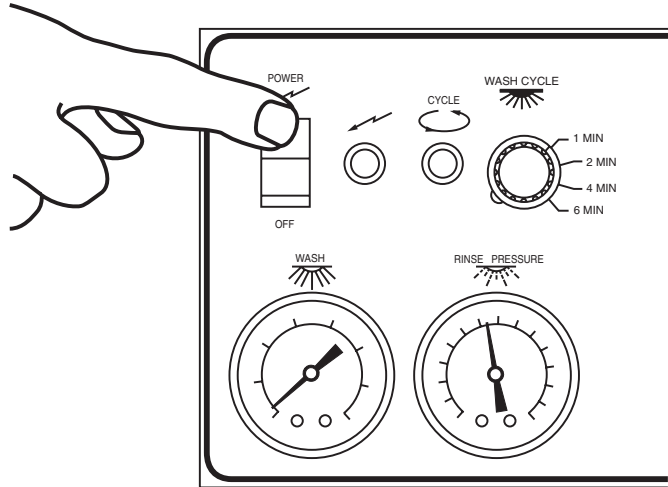

4

Note that the power indicator light is illuminated.

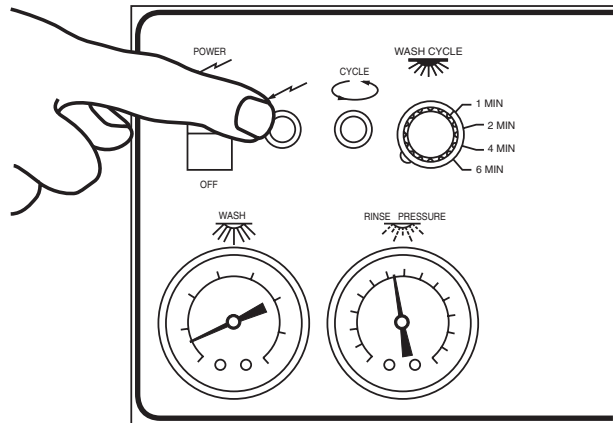

5

Check Wash Water Temperature

The wash tank heater and the booster tank heater (D-HBT only) will begin to heat the water in the dishwasher.

Wait approximately 10 minutes for the wash tank water to reach operating temperature. The temperature should be a minimum of 150°F/66°C for (D-HBT, D-H1T).

Prescrap the dishes. Load ware into the dishrack. Open the doors, insert the rack into the dishwasher.

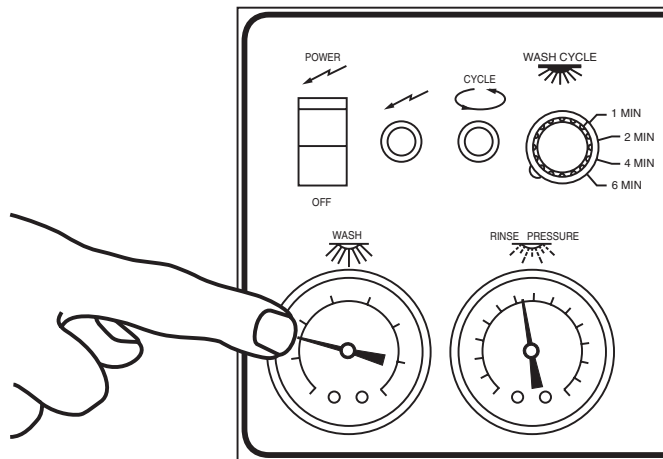

INITIAL START-UP (Cont.)

6

Fully close the dishwasher doors.
The dishwasher will begin the automatic cycle.

Opening the doors anytime during the cycle will stop the dishwasher.

Closing the doors will resume the automatic cycle where it left off.

The cycle times are listed below:

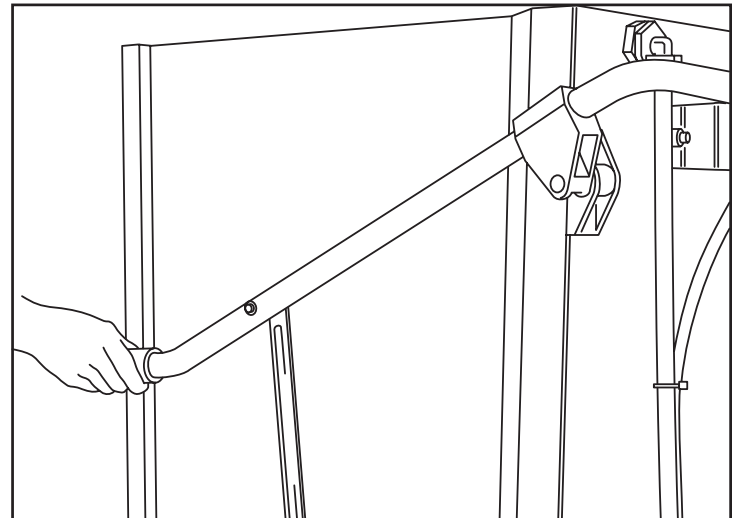

1 Minute Wash Cycle Setting

Wash = 45 seconds
Dwell = 1 second
Final rinse = 18 seconds
Dwell = 4 seconds (completion of cycle)

2 Minute Wash Cycle Setting

Wash = 97 seconds
Dwell = 1 second
Final rinse = 18 seconds
Dwell = 4 seconds (completion of cycle)

4 Minute Wash Cycle Setting

Wash = 217 seconds
Dwell = 1 second
Final rinse = 18 seconds
Dwell = 5 seconds (completion of cycle)

6 Minute Wash Cycle Setting

Wash = 337 seconds
Dwell = 1 second
Final rinse = 18 seconds
Dwell = 4 seconds (completion of cycle)

7

Note that the in-cycle light is lit during the automatic dishwasher cycle.

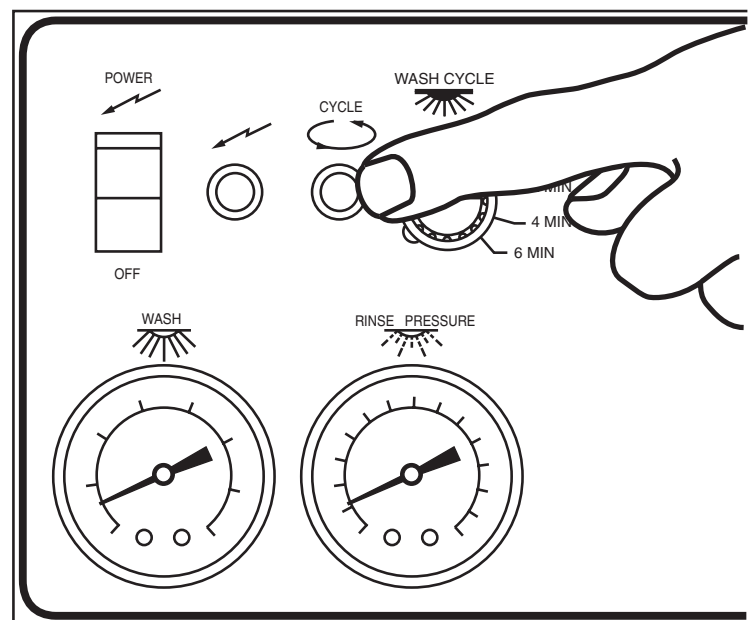

INITIAL START-UP (Cont.)

8

Check Final Rinse Water Temperature

Check the final rinse water temperature during the final rinse cycle.

The final rinse water temperature gauge is located in the final rinse piping at the top of the dishwasher.

The final rinse water temperature should be a minimum of 180°F/82°C for (D-HBT, D-H1T). The optimum final rinse temperature for (D-HBT, D-H1T) is 180-195°F/82-91°C.

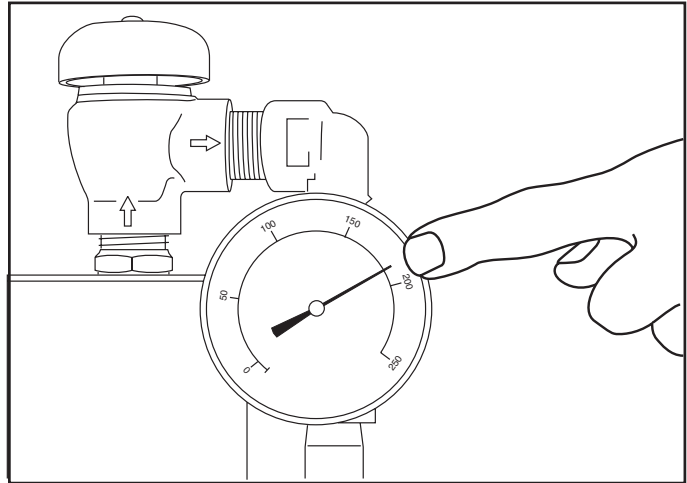

9

Check Final Rinse Water Pressure

The final rinse water pressure gauge should indicate a flowing pressure of 20-22 PSI/138-151.8 kPa during the final rinse cycle for all models.

A pressure reducing valve (PRV) is required if flow pressure exceeds 20-22 PSI/138-151.8 kPa.

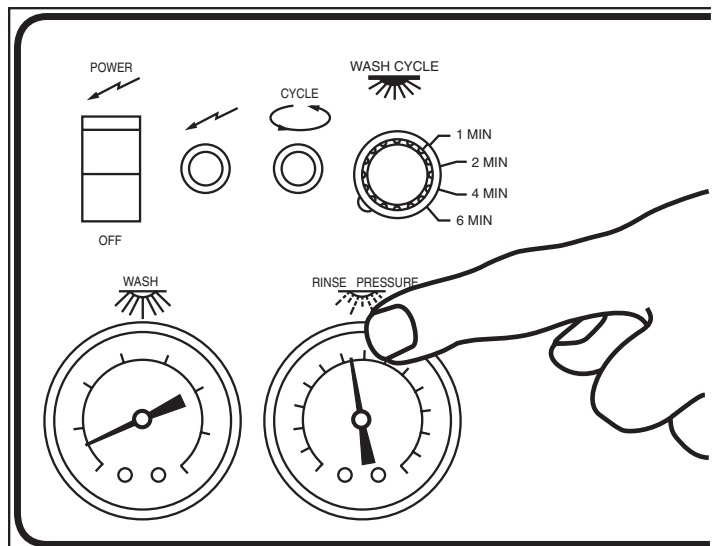

INITIAL START-UP (Cont.)

10

The Wash Cycle Selector Switch

The wash cycle selector switch provides the option of choosing four different dishwasher cycle times.

To select a cycle time —

Make sure power is on and the dishwasher has completed its last cycle.

Turn the selector knob to the desired time as indicated on the control panel.

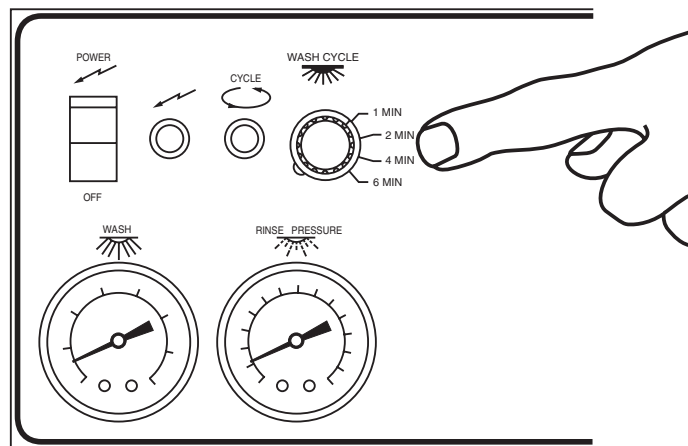

Close the doors.

The dishwasher will begin the cycle automatically.

If the timed fill is activated due to a loss of water, the cycle will stop. When the dishwasher is full the automatic cycle will resume where it left off.

*The maximum total wash cycle time is 6 minutes.
For example: You can not select 4 minutes then turn the switch to 6 minutes during the automatic 2 minute cycle to extend the total cycle to 10 minutes.*

The dishwasher cycle times are listed below:

1 Minute Wash Cycle Setting

Wash	=	45 seconds
Dwell	=	1 second
Final rinse	=	18 seconds
Dwell	=	4 seconds (completion of cycle)

4 Minute Wash Cycle Setting

Wash	=	217 seconds (3 min 37 sec)
Dwell	=	1 second
Final rinse	=	18 seconds
Dwell	=	4 seconds (completion of cycle)

2 Minute Wash Cycle Setting

Wash	=	97 seconds (1 min 37 sec)
Dwell	=	1 second
Final rinse	=	14 seconds
Dwell	=	4 seconds (completion of cycle)

6 Minute Wash Cycle Setting

Wash	=	337 seconds (5 min 37 sec)
Dwell	=	1 second
Final rinse	=	14 seconds
Dwell	=	4 seconds (completion of cycle)

INITIAL START-UP (Cont.)

11

Complete the initial start-up

Check all the plumbing for leaks. Also, check the drain plumbing for leaks and be sure that the drain will handle the drain water flow (15 gal/min-56.8 liters/min) from the dishwasher.

After the drain and the plumbing connections are checked, turn off the dishwasher power switch.

12

Drain the dishwasher

Make sure the dishwasher power switch is turned off.

When power is switched to the **OFF** position machine will drain automatically for ten minutes.

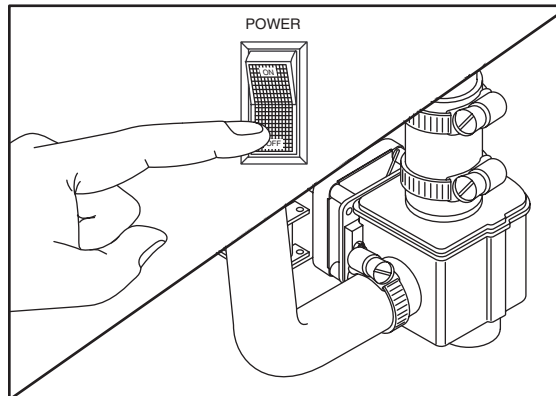

Remove the scrap screens and check the drain located in the bottom of the dishwasher wash tank.

Make sure that the building drain handles the water flow exiting the dishwasher.

Clean the interior of the wash tank of any foreign material.

Leave the doors open to air dry the interior of the dishwasher.

The initial start-up is complete.

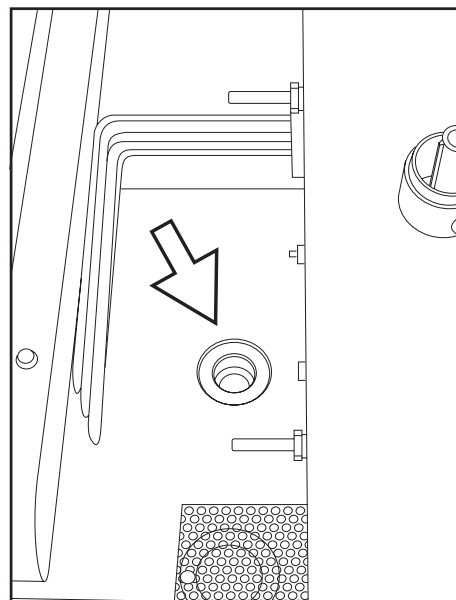

OPERATION SUMMARY

Action	Result
1. Push the On/Off power switch “UP” to the ON position. Dishwasher fills automatically.	1. The power indicator light illuminates. The wash tank heater (D-HBT/H1T) and the booster tank heater (D-HBT) begin to heat.
2. Wait approximately 10 minutes for the wash tank heater to heat the water. Then, check the reading on the wash water temperature gauge.	2. The wash water temperature gauge should indicate a minimum of 150°F/66°C for D-HBT, D-H1T.
3. Prescrap and load the ware into the dishrack.	3. Ware should be placed edgewise in the peg rack. Cups and bowls should be placed upside down in the flat rack. Silverware should be spread evenly in a single layer in the flat rack.
4. Open the doors. Insert a dishrack of soiled ware. Fully close the doors. Opening the doors anytime during the automatic cycle stops the dishwasher. Closing the doors will resume the cycle where it left off.	4. In cycle light illuminates as the dishwasher begins a selected automatic cycle. The total cycle times are listed below: 1 minute = 45 second wash 2 minute = 1 minute 37 second wash 4 minute = 3 minute 37 second wash 6 minute = 5 minute 37 second wash
5. Check the final rinse temperature gauge reading during the 14 second final rinse cycle.	5. The final rinse temperature gauge should indicate a minimum of 180°F/82°C for D-HBT/D-H1T. The optimum final rinse temperature range is between 180-195°F/82-90°C.
6. Check the incoming water pressure during the 14 second final rinse cycle.	6. The water pressure gauge should indicate a flowing pressure of 20-22 PSI/138-151.8 kPa. A pressure reducing valve (PRV) is required if flow pressure exceeds 20-22 PSI/138-151.8 kPa.
7. The selected automatic cycle ends.	7. The in cycle light goes out.
8. Open the doors. Remove the clean rack. Insert another rack of soiled ware. Fully close the doors.	8. The selected automatic cycle begins again.
9. Turn power OFF at the dishwasher. Clean the scrap screens. Clean the dishwasher after each meal period or every two hours of operation. After initial draining of tank, if you should need to continue draining, flip power switch to ON then OFF to redrain.	9. Dishwasher drain valve opens for ten minutes automatically. Periodic cleaning reduces detergent consumption and improves washing results.

CLEANING

Cleaning your machine is the best maintenance that you can provide. Components that are not regularly flushed and cleaned do not perform well.

The following schedules are the minimum requirements necessary for the proper performance of your machine. Intervals should be shortened whenever your machine is faced with abnormal working conditions, hard water, or multiple shift operations.

CLEANING SCHEDULE

Every 2 Hours or After Each Meal Period

1. Drain the dishwasher.
2. Flush interior with fresh water.
3. Clean scrap screens and pump intake screen.
4. Clean spray arm nozzles.

Every 8 Hours or at the End of the Day

1. Flip power switch to OFF position to open drain valve for 10 minutes.
2. Flush interior with fresh water.
3. Clean scrap screens and pump intake screen.
4. Clean spray arms.
5. Thoroughly clean the exterior of machine.

DO NOT HOSE DOWN WITH WATER.

6. Flip power switch ON then OFF to drain machine, as needed.
7. Reassemble the machine.
8. Leave doors open to aid in drying.



CAUTION:

Do not leave water in wash tank overnight.

DELIMING

Your dishwasher should be delimed regularly depending on the mineral content of your water. Inspect the machine interior for mineral deposits and use a deliming solution for the best cleaning results.

NOTE:

Consult your chemical supplier for an appropriate deliming solution.



WARNING:

Deliming solutions or other acids must not come in contact with household bleach (sodium hypochlorite) or any chemicals containing chlorine, iodine, bromine, or fluorine. Mixing will cause hazardous gases to form. Skin contact with deliming solutions can cause severe irritation and possible chemical burns. Consult your chemical supplier for specific safety precautions.

DELIMING PROCESS

Model D-HBT and D-H1T

1. Remove all dishes from machine.
2. Remove any chemical pick-up tubes from their containers.
3. Place each tube in a container of fresh water and prime the chemical lines for several minutes to thoroughly flush chemical from the lines. Leave pick-up tubes out of their containers.
4. Flip the power switch OFF to drain the machine for 10 minutes, return power switch to ON position to refill with fresh water.
5. Spray interior walls with deliming solution and let sit for 5 or 10 minutes depending on amount of build-up. Add deliming solution to wash tank.
Do not let chemicals sit for longer than 15 minutes.
6. Close the doors to run an automatic cycle.
7. Repeat Steps 4-6 if necessary.
8. Flip the power switch to OFF to drain the machine for 10 minutes.
9. Turn switch to ON position to refill the machine and run a complete cycle two additional times. Drain and refill the machine after each cycle to thoroughly flush any deliming solution from the interior of the machine.
10. Flip the power switch to OFF to drain machine for 10 minutes.
11. Deliming is complete.

TROUBLESHOOTING

Perform the seven checks listed below in the event that your dishwasher does not operate as expected.

1. All switches are ON
2. Wash and rinse nozzles are clean
3. Wash and rinse pipe assemblies are installed correctly
4. Scrap screens are properly positioned
5. Thermostat(s) are properly adjusted
6. Detergent and rinse additive dispensers are adequately filled

If a problem still exists, use the following table for troubleshooting

CONDITION	CAUSE	SOLUTION
Machine will not start	Doors not closed	Make sure doors are fully closed
	Door safety switch faulty	Contact your service agency
	Main switch off	Check disconnect at main panel
	Blown Fuse	Replace fuse
Machine washes constantly	Timer or door switch defective	Contact your service agency
Low or no water	Main water supply is turned off	Turn on house water supply
	Faulty drain valve	Turn off power at main switch, pull lever on valve to drain. Contact your service agency
	Machine doors not fully closed	Close doors securely
	Faulty fill valve	Contact your service agency
	Machine not filled initially	Push Power switch UP to fill
	Clogged strainer in fill valve	Clean or replace
Continuous water filling	Stuck or defective float	Check floats and clean
	Defective Circuit Board	Contact your service agency
	Fill valve will not close	Clean or replace
	Drain valve will not close	Replace drain valve/contact your service agency
Wash motor not running	Stuck or Defective float switch	Inspect or replace float switch
	Overload protector tripped	Reset overload in Control Box
Wash tank water temperature is low when in use	Defective motor	Contact your service agency
	Incoming water temperature at machine too low	Raise temperature to: 110-140°F/43-60°C for D-HBT 180°F/82°C for D-H1T
	Defective thermometer.....	Check or replace
	Defective thermostat	Check for proper setting or replace
	Defective heater element	Check or replace
	Defective solenoid valve	Check or replace
	Heater elements	Clean and delime have soil/lime buildup

TROUBLESHOOTING (Cont.)

CONDITION	CAUSE	SOLUTION
Insufficient pumped spray pressure	Clogged pump intake screen	Clean
	Clogged spray pipe	Clean
	Scrap screen full	Must be kept clean and in place
	Pump motor rotation incorrect	Reverse connection between L1 and L2 in Control Cabinet
	Defective pump seal	Contact Service Agent
Insufficient final rinse or no final rinse	Faulty pressure reducing valve	Clean or replace
	Improper setting on pressure reducing valve	Set flow pressure at 20-22 PSI/ 138-151.8 kPa
	Clogged rinse nozzle and/or pipe	Clean
	Improper water line size	Have installer change to proper size
	Clogged strainer in fill valve	Clean or replace
Low final rinse temperature	Low incoming water temperature	Check the booster (D-HBT, D-HIT) be sure the thermostat is set to maintain 180°F/82°C temperature.
	Solenoid valve defective.....	Check valve to be sure it is clean and operating
	Defective thermometer	Check for proper setting or replace
Poor washing results	Detergent dispenser	Contact detergent supplier
	not operating properly	
	Insufficient detergents	Contact detergent supplier
	Wash water temperature	See condition "Wash Tank Water Temperature" above
	too low	
	Wash arm clogged	Clean
	Improperly scraped dishes	Check scraping procedures
	Ware being improperly placed in rack	Use proper racks. Do not overload racks
Improperly cleaned equipment	Unclog wash sprays and rinse nozzles to maintain proper pressure and flow conditions. Keep wash water as clean as possible.	
Heater elements.....	Clean and delime	
have soil/lime buildup		

BASIC SERVICE

This Basic Service section does not cover all possible repair procedures. If you require additional service support, you may call your local service company or:

Champion National Service

USA: 1-800-858-4477

Canada: 1-800-263-5798

Please have the Model and Serial Number of the machine ready when you call.

ELECTRICAL SERVICE



NOTE:

DO NOT USE CHASSIS GROUND WHEN PERFORMING VOLTAGE CHECKS.

Doing so will result in false and inaccurate readings.

PERFORM VOLTAGE CHECKS BY READING FROM THE HOT SIDE OF THE LINE AND NEUTRAL (any #2 or white wire).



WARNING:

USE EXTREME CAUTION when performing tests on energized circuits.



WARNING:

When repairing a circuit, disconnect the power at the main service disconnect switch and place a tag at the disconnect switch to indicate that work is being performed on the circuit.

Troubleshooting

Schematics

Champion places an electrical schematic in the control cabinet of every machine before it is shipped. Schematics are included at the back of this manual as well. Be aware that these schematics include options that may not apply to your machine. Options are enclosed in dashed lines with the words (IF USED) next to them on the schematic. Disregard any options that appear on the schematics which are not a part of your machine.

Tools

All electrical repairs can be made with:

- Standard set of hand tools
- Volt/Ohm Meter (VOM)
- Clip-on AC current tester

Circuit Tests

Use a clip-on AC current tester to check the motors and electric heaters.
Use a VOM to test line voltages and the 115VAC control circuit.

ELECTRICAL SERVICE (Cont.)

Fuses —

Refer to Fig. 11.

There are two fuse blocks. A 3-pole block (A) is located in the main control cabinet. The (A) fuses protect the wash tank heater circuit. Booster heater circuits (D-HBT only) are not fused. A 2-pole fuse block is located on the machine base to protect the control circuit.

To Replace a fuse:

Turn the dishwasher main power switch off. Disconnect power to the machine at the main service disconnect switch.

Replace the fuse. If the fuse blows again, **DO NOT INCREASE THE FUSE SIZE. DETERMINE THE CAUSE OF THE OVERLOAD.**

Motor Overloads —

The wash pump motor has an overload to protect it from line voltage electrical overloads. The overload disconnects 120VAC power to the motor contactor coil.

Refer to Fig. 12.

Note the Switch Lever on the Overload.

If the switch lever is off with the “0” showing then the overload has tripped.

To Reset the Motor Overload:

Flip the overload switch to the On position. A “1” should be visible on the switch lever.

To Replace a Motor Overload:

Disconnect the wires to the overload. Release the mounting catch on the front side of the overload. Push forward and lift out. Snap the new overload into place and reconnect the wires.

To adjust the overload setting:

The screwdriver in Fig. 12 is positioned to adjust the motor overload AMP setting. Read the full load amps (FLA) motor amps on the motor nameplate. Turn the setting to match the name plate.

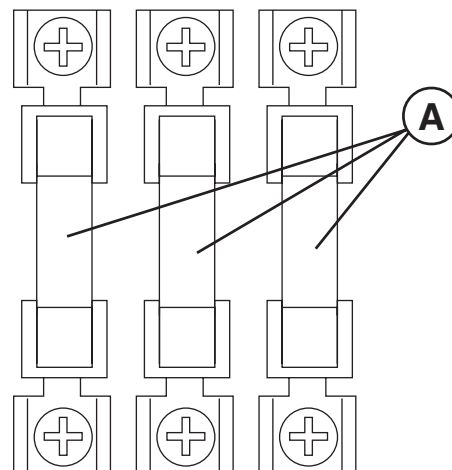

Figure 11
Wash Tank Heater Fuses
Control Cabinet

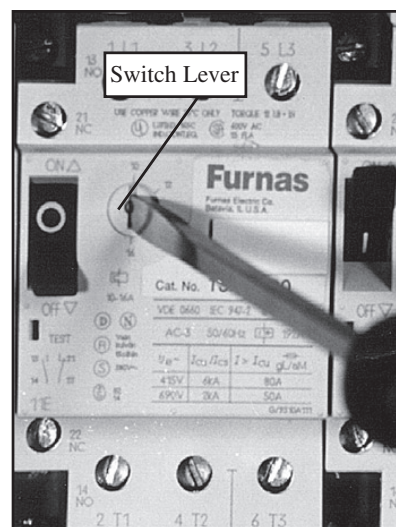

Figure 12
Motor Overload

SOLID STATE D-HBT AND D-H1T OPERATING INSTRUCTIONS

Automatic Operation

1. Check that screens are clean and in place.
2. Turn on main power to the machine.
3. Flip machine control panel power switch to ON.
4. Close doors.
 - Machine pauses 4 seconds to check water level.
5. Machine fills for 110 seconds if float is down.
6. Run machine through several cycles or wait 10 minutes (on initial start up) for temperature to stabilize.
7. Open door, insert rack of dishes.
8. Close doors. Automatic cycle begins (at selected time set on selector switch).
9. Machine cycle is:

1 Minute Cycle

Wash = 45 secs.

Dwell = 1 sec.

Rinse = 18 secs.

2 Minute Cycle

Wash = 97 secs.

Dwell = 1 sec.

Rinse = 18 secs.

4 Minute Cycle

Wash = 217 secs.

Dwell = 1 sec.

Rinse = 18 secs.

6 Minute Cycle

Wash = 337 secs.

Dwell = 1 sec.

Rinse = 18 secs.

Each cycle has a 4 second Dwell after Rinse completes.

10. Open door, remove clean rack of dishes.
11. Repeat for additional racks.

TROUBLESHOOTING TIMER CIRCUIT BOARD

1.1 Introduction

The following procedures are for determining whether or not the timer circuit board itself is faulty.

In this part –

- Checking the general condition of the circuit board.
- Testing inputs.
- Testing outputs.

Special Tools

- A voltmeter capable of reading DC and AC volts.

1.2 Checking General Condition

Before testing the inputs and outputs, you should first check that the board is receiving power.

Turn on the power switch to the unit (do not start the unit, just turn on power to the unit). If red “Power” LED on board is illuminated, go directly to **1.3**. When LED is not illuminated, then check that the following conditions are true:

TROUBLESHOOTING TIMER CIRCUIT BOARD (cont.)

Power Terminals

- Verify that the board is receiving power of 120 VAC at the terminals:
 - T2, marked “H” (AC Hot).
 - T1, marked “N” (AC Neutral).

If either of these terminals is not receiving 120 VAC, then there is a problem elsewhere with the unit not receiving power.

The Fuse (F1)

- Verify that the circuit board fuse (F1) is good.
- If it is not, replace it.

Red ‘Power’ LED

- Verify that the red ‘power’ LED is illuminated.
- If it is not, and the previous 2 conditions are true, then the board is bad and should be replaced.

1.3 Testing Board Inputs

After you have verified that the circuit board is receiving power (as explained above), then test the board inputs. There are 4 board inputs:

- Start Switch.
- Door Safety Switch.
- Float Switch.
- Extended Wash Switch (if installed).

Perform the following steps to test a board input:

1. Set the voltmeter to measure *DC volts*.
2. Place the negative (black) test probe on the “hot” terminal:
 - T2, marked “H”.
3. Place the positive (red) test probe on the input terminal to be tested:
 - T7, marked “START SW” (for the start switch, not used on D-HBT or D-H1T).
 - T8, marked “DOOR SW” (for the door safety switch).
 - T9, marked “FLOAT SW” (for the float switch).
 - T10, marked “EXT. WASH” (for the extended wash switch, not tested on D-HBT or D-H1T).
4. Check the results on the voltmeter:
 - *If switch is opened* – the meter should read between 4.7 to 5.3 DC volts.
 - *If the switch is closed* – the meter should read between 0 to 1 DC volts.



1.4 Testing Board Outputs

After you have verified that the circuit board is receiving power (as explained above), then test the board outputs. There are 4 board outputs:

- Wash Cycle.
- Rinse Cycle.
- Heaters.
- In-Cycle Lamp.

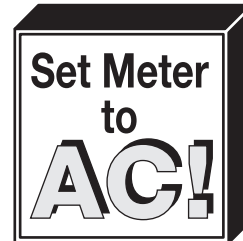

Perform the following steps to test a board output:

1. Set the voltmeter to measure *AC volts*.
2. Place the negative (black) test probe on the “neutral” terminal:
 - T1, marked “N”.
3. Place the positive (red) test probe on the output terminal to be tested:
 - T3, marked “WASH OUTPUT” (for the wash cycle) (doors must be closed before testing).
 - T4, marked “RINSE OUTPUT” (for the rinse cycle) (doors must be closed before testing).
 - T5, marked “HEATERS OUTPUT” (for the water heater).
 - T6, marked “LAMP OUTPUT” (for the in-cycle lamp indicator).
4. Check the results on the voltmeter for the terminal you are testing:
 - **For T3** – the meter should read 120 VAC whenever the unit is in-cycle and the “WASH” LED is illuminated on the circuit board.
 - **For T4** – the meter should read 120 VAC whenever the unit is in a fill or rinse mode and the corresponding “FILL” or “RINSE” LED is illuminated on the circuit board.
 - **For T5** – the meter should read 120 VAC whenever the power switch is on and the wash tank is full (i.e., the float switch is up).
 - **For T6** – the meter should read 120 VAC whenever the machine is in-cycle.

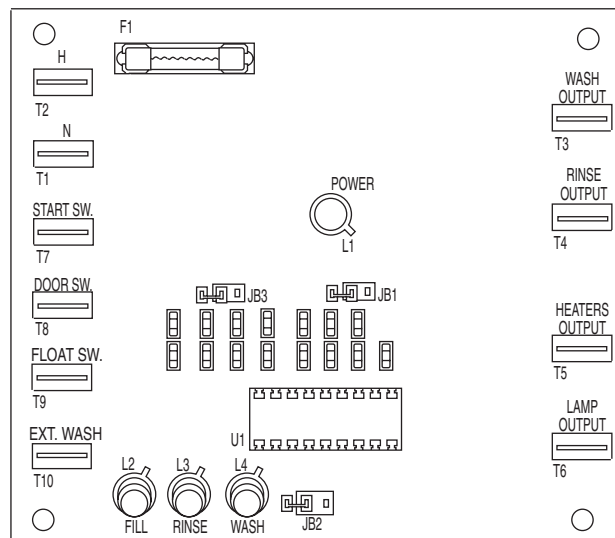

Figure 13
Solid State
Control Board

Models D-HBT and D-H1T use a float switch and circuit board to control tank fill and tank heat.

For Model D-HBT only, the built-in booster heat circuit is also controlled by the float switch.

Operation:

1. When dishwasher main power switch is turned on (wash tank empty), the drain valve closes allowing cycle time to run for a minimum of 110 seconds to fill the tank.
2. The float switch ball rises; its normally open contacts close. The fill circuit times out; the fill solenoid de-energizes, and the tank heat and booster heat energize.
3. If water level drops below the float level, the float switch ball moves down; heat de-energizes. The fill solenoid energizes and the fill cycle runs for a minimum of 110 seconds to refill the tank.
4. If the tank is not full of water at the end of the 110-second fill cycle, then the machine will cycle again. When the float switch is satisfied, the fill cycle stops after completing its 110-second cycle.
5. Refer to the float switch troubleshooting chart below (Fig. 15) for a quick guide to evaluating float switch problems.



**Figure 14
Float Switch**

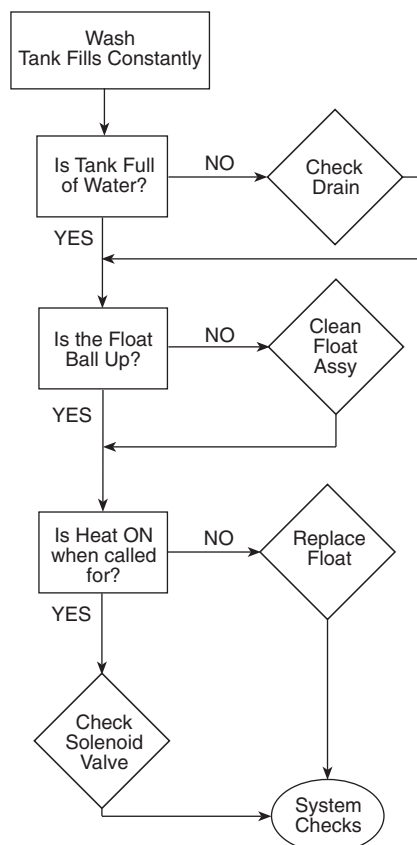

**Figure 15
Float Switch
Troubleshooting Chart**

ELECTRICAL SERVICE (Cont.)

Heater Element Wiring – Booster Tank and Wash Tank Heater Elements

Refer to the illustrations and follow the steps below to properly install terminal jumpers and to make line power connections to a replacement element.

Step 1. Hold the element assembly with the calrod coils facing toward you.

Step 2. Match your element coil to Configuration A, B, C, or D.

Step 3. Rotate your element coils to match the correct configuration.

Step 4. Turn the element over and match your element to the correct terminal configuration.

Step 5. Install terminal jumpers according to the illustration for your voltage requirement.

Step 6. Install the element and make your line connections 1L1, 1L2, or 1L3 per the illustration.

Configuration A

Booster tank element

View of calrod coils

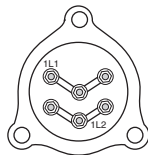
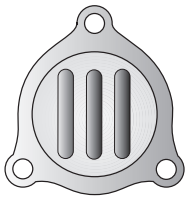

208V/1 Phase

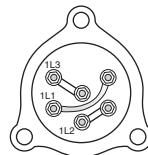

208-240V/3 Phase
Delta Connection

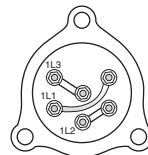

480V/3 Phase
575V/3 Phase
Delta Connection

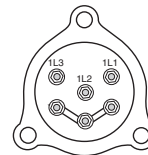

208-240V/3 Phase
Wye Connection for
380-415V/3 Phase

Terminal Connections View of element

Configuration B

Booster tank element

View of calrod coils

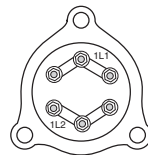
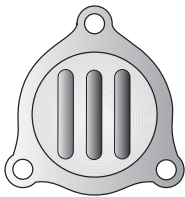

208V/1 Phase

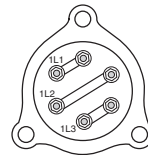

208-240V/3 Phase
Delta Connection

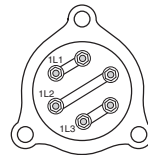

480V/3 Phase
575V/3 Phase
Delta Connection

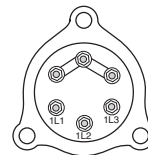

208-240V/3 Phase
Wye Connection for
380-415V/3 Phase

Terminal Connections View of element

Configuration C

Booster tank element

View of calrod coils

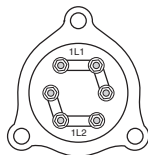

208V/1 Phase

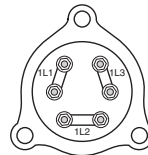

208-240V/3 Phase
Delta Connection

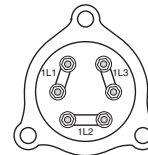

480V/3 Phase
575V/3 Phase
Delta Connection

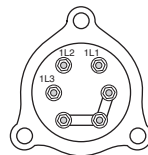

208-240V/3 Phase
Wye Connection for
380-415V/3 Phase

Terminal Connections View of element

Configuration D

Wash tank element

View of calrod coils

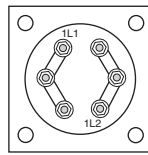
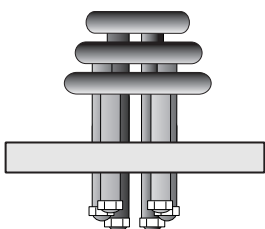

208V/1 Phase

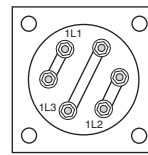

208-240V/3 Phase
Delta Connection

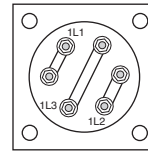

480V/3 Phase
575V/3 Phase
Delta Connection

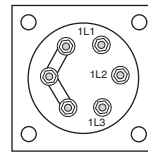

208-240V/3 Phase
Wye Connection for
380-415V/3 Phase

Terminal Connections View of element

Figure 16
Heater Element Wiring

ELECTRICAL SERVICE (Cont.)

Motor Connections —

1. Models D-HBT and D-H1T are available in either single phase or 3 phase voltages.
2. Motor rotation was set at the factory. For three phase machines, reversing the motor direction is done in the control cabinet by reversing the wires L1 and L2 on the disconnect side of the main electrical connection block. For single phase machines, motor rotation is changed at the motor connection plate on the rear of the single phase motor (if necessary).

Refer to Fig. 17 for the proper wiring of the pump motor for single and three phase voltages.

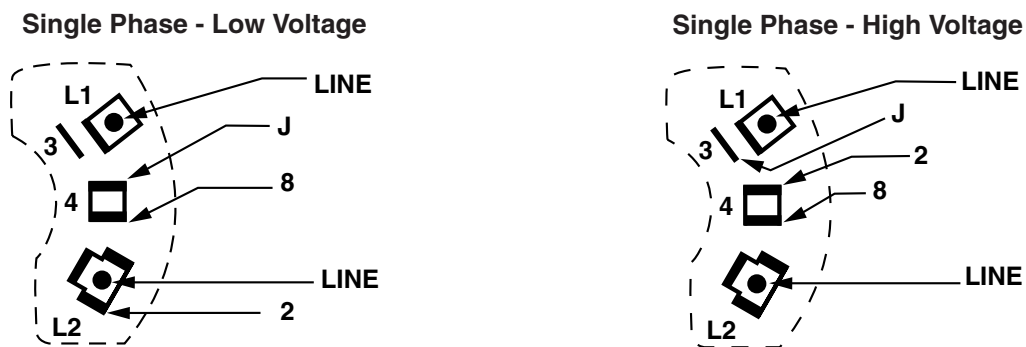
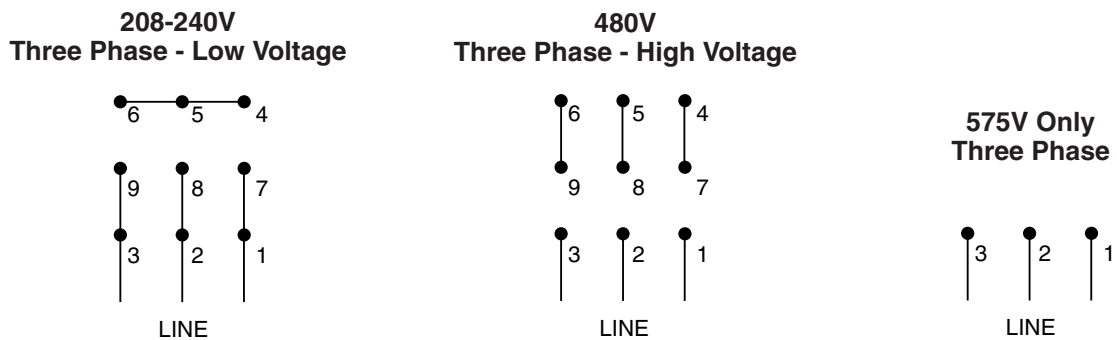

Figure 17
Pump Motor Wiring Diagrams



MECHANICAL SERVICE

Pump Seal Replacement

1. Disconnect the power to the machine at the main breaker panel or fuse box.
2. Drain the machine.
3. Remove the front and side panels.
4. Remove drain plug on the pump volute and drain the pump.
5. Remove the pump hoses.
6. Disconnect the wires to the motor at the motor junction box.
7. Unbolt motor from machine base and remove the pump/motor assembly.
8. Remove bolts on volute and carefully remove from the pump flange.
9. Remove the impeller retaining bolt and nut from center of impeller.
10. Lock the motor shaft with a wrench or pliers. The back of motor shaft is square.
11. Turn the impeller counter-clockwise to remove from shaft (right hand threads).
12. Remove the old seal and discard.
13. Check seal seat in the pump flange and clean thoroughly.
14. Press rubber seal/ceramic portion of seal assembly into the pump flange. Use a water soluble lubricant. Be careful to keep the ceramic clean.
15. Install the rotating part of the seal on the shaft with the graphite surface toward the ceramic. Use a water soluble lubricant on the rubber seal part only (not the graphite).
16. Reinstall impeller, and new flange gasket. Reinstall bolts. Reinstall drain plug.
17. Reinstall the pump/motor assembly and reconnect the pump hoses.
18. Fill the dishwasher with water.
19. Check motor rotation by bump starting motor.
Correct motor shaft rotation is clockwise when viewing motor from the rear.
20. Test run and check for leaks.

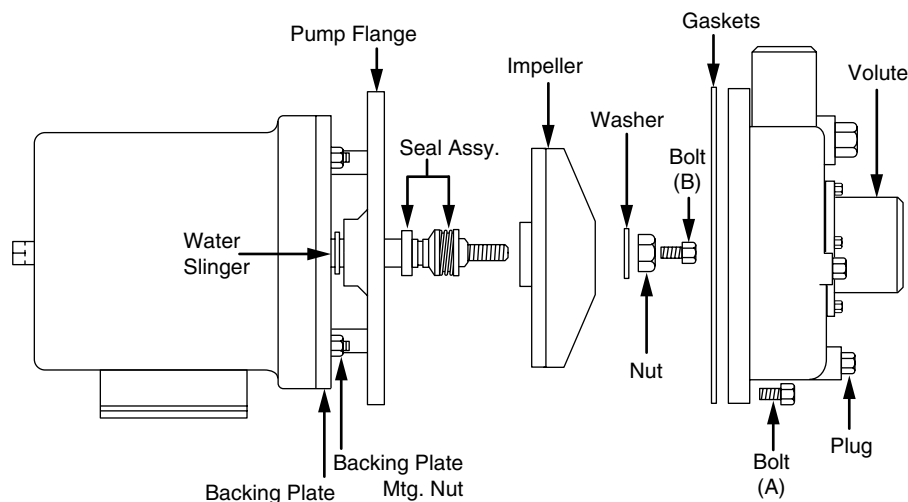

Figure 18
Pump Seal Replacement

REPLACEMENT PARTS

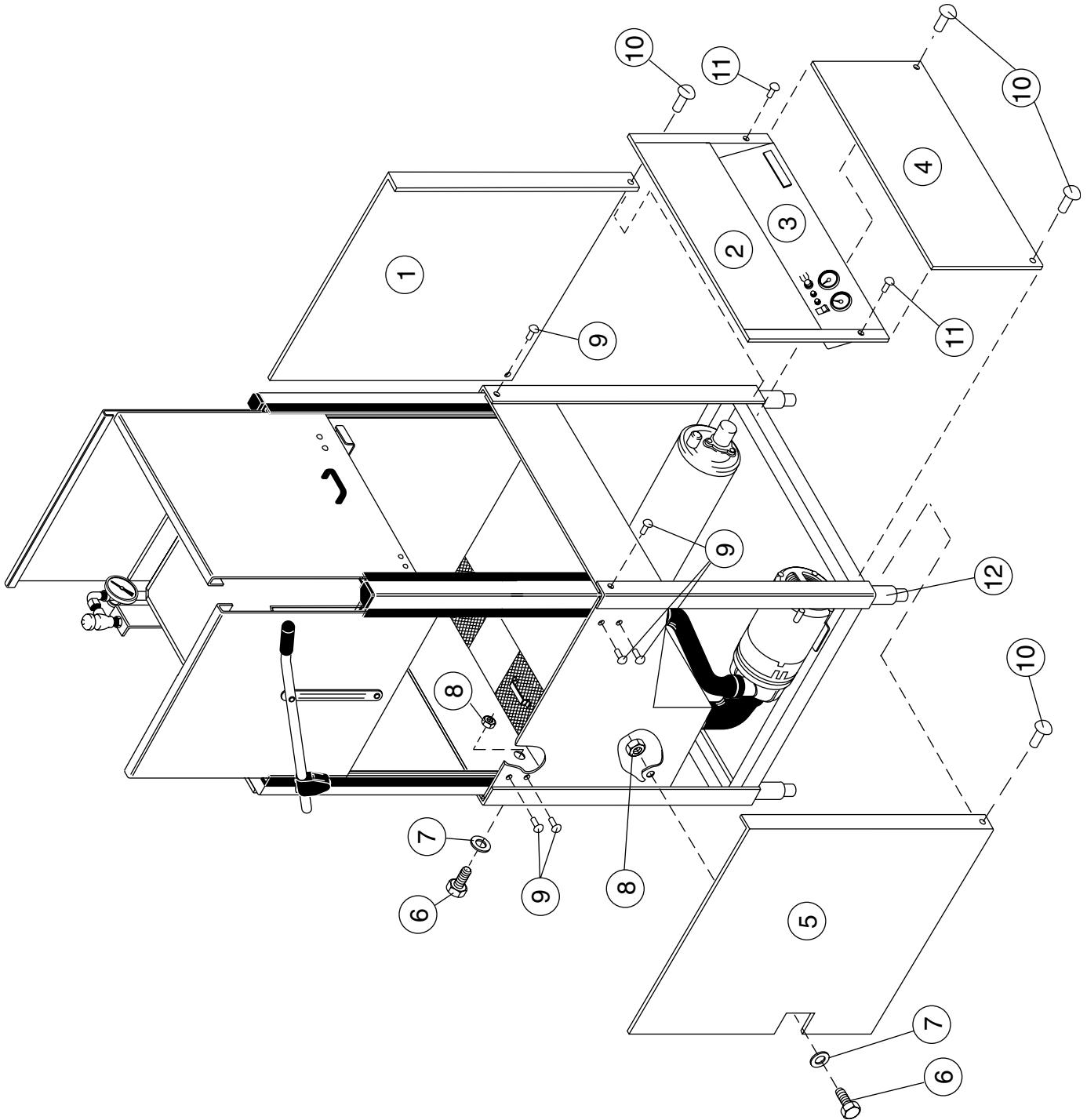

Figure 19 - D-HBT/D-H1T
Panels

**D-HBT/D-H1T
PANELS**

Fig. 19 Item No.	Part No.	Part Description	Qty.
1	321929	RH Panel No Cut Out	1
2	324588	Panel, Instrument	1
3	113051	Label, Panel Overlay DH-T/TC	1
4	322074	Panel, Front Lower	1
5	321941	LH Panel W/Cut Out	1
6	108418	Plug Plastic	2
7	109034	Washer 13/16 x 1-13/16 Fiber	2
8	108417	Nut, Plastic	2
9	100779	Screw, 1/4-20 x 5/8 Truss Head	6
10	0504822	Screw, 8-32 x 1/2 Pan Head	4
11	100763	Screw, 10-32 x 1-1/4 Round Head	2
12	112587	Foot, Cast Grey	4

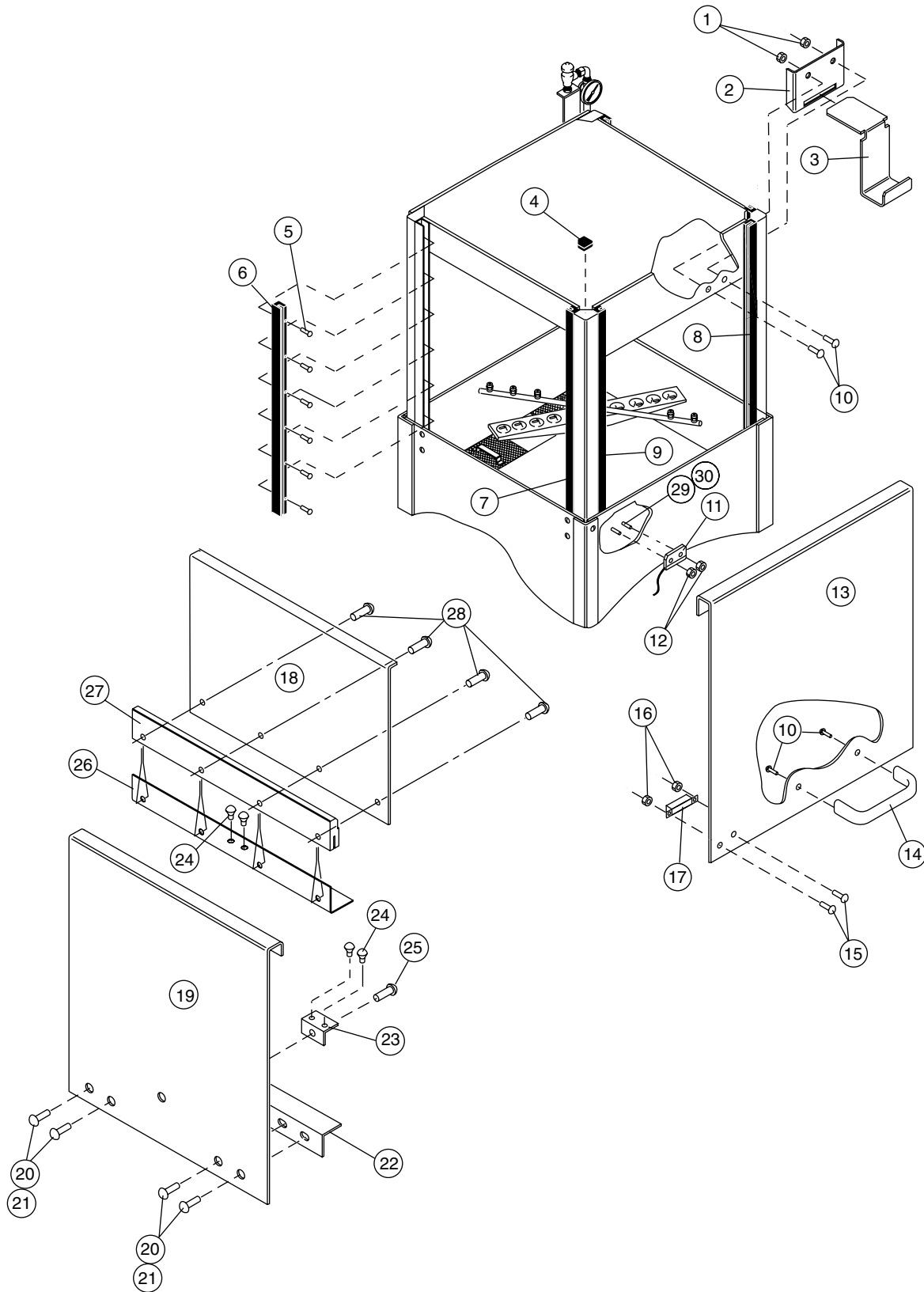

Figure 20 - DHB-T/DH1-T
Doors, Guides, & Stops

**DHB-T/DH1-T
DOORS, GUIDES, AND STOPS**

Fig 20 Item No.	Part No.	Part Description	Qty.
1	100141	Nut, Grip 1/4-20 SST	2
2	317345	Bracket, Door Catch	1
3	317344	Hook, Door Catch	1
4	108053	Plug, Corner Post	2
5	107970	Screw, 8/32 x 1" Filister Head	48
6	112704	Door Guide, Side Door Left	2
7	112705	Door Guide, Side Door Right	2
8	112703	Door Guide, Front Door Left	1
9	112702	Door Guide, Front Door Right	1
10	100073	Screw, 1/4-20 x 1/2 Truss Head	3
11	112659	Hamlin Reed Switch	1
12	108954	Nut Grip 6-32	4
13	322790	Door Front	1
14	112687	Door Handle	1
15	106382	Screw, 6-32 x 3/8 Truss Head	2
16	108954	Nut, Grip 6-32	2
17	111026	Magnet	1
18	325633	Side Door, Upper	2
19	322788	Side Door, Lower	2
20	100097	Screw 10-32 x 1/2 Truss Head	8
21	107966	Nut, Grip 10-32	2
22	322077	Splash Guard	2
23	323006	Door Stop	2
24	107893	Shock Absorber	8
25	112723	Bolt, 5/16-18 x 15 Full Thread	2
26	323305	Angle, Door Stop	2
27	112772	Stop, Delrin Splash Baffle	2
28	100097	Screw, 10-32 x 1/2 Truss Head	8

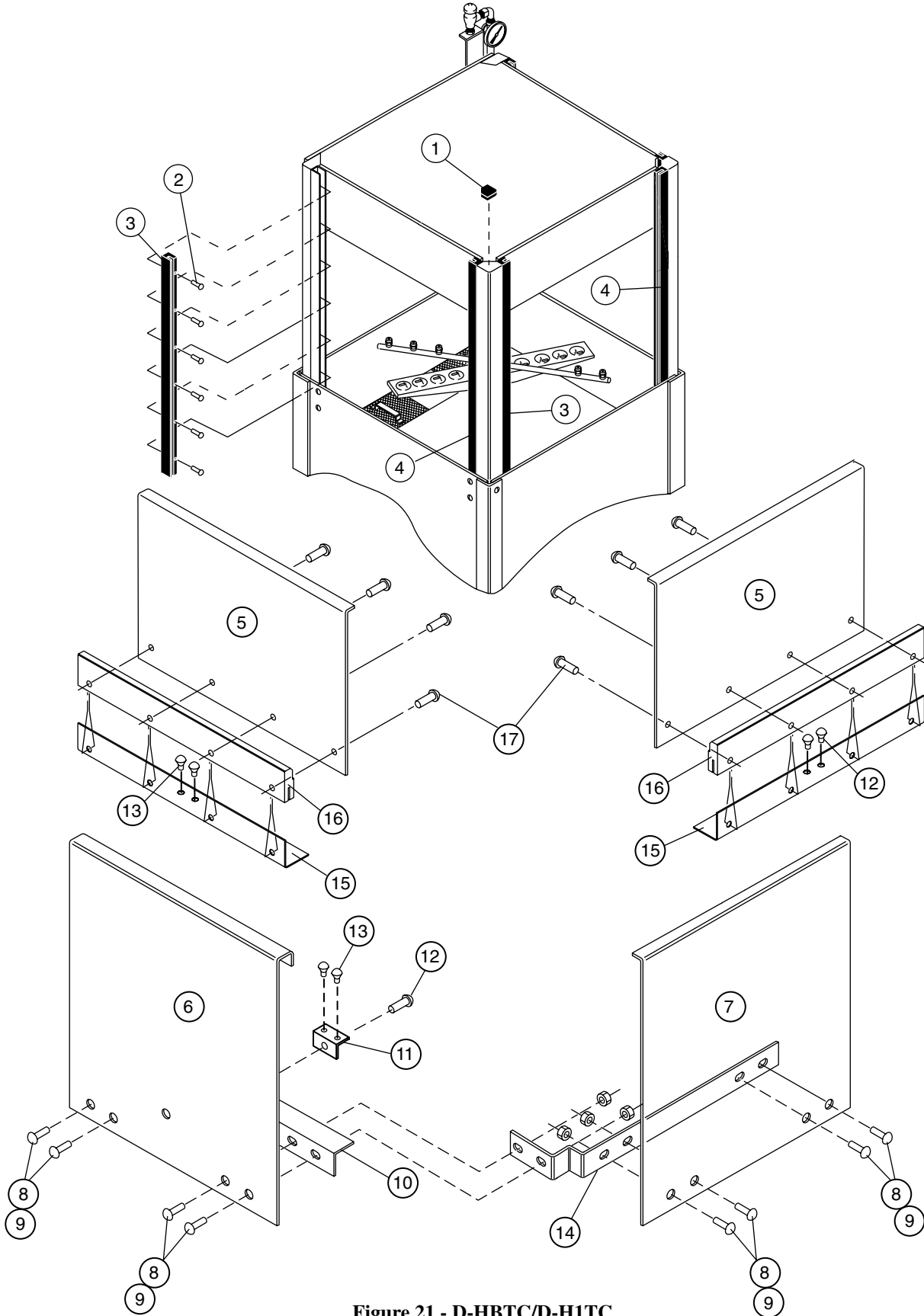

Figure 21 - D-HBTC/D-H1TC
Doors, Guides, & Stops (Corner Model Only)

**D-HBTC/D-H1TC
DOORS, GUIDES, AND STOPS**

Fig 21 Item No.	Part No.	Part Description	Qty.
1	108053	Plug, Corner Post	2
2	107970	Screw 8-32 x 1 Filister Head	32
3	112704	Guide, Door Left	2
4	112705	Guide, Door Right	2
5	325633	Door, Side Upper	2
6	322788	Door, Lower Side	1
7	323221-S	Door, Lower Front	1
8	100007	Screw 10-32 x 3/8 Truss Head	6
9	104985	Nut, Plain 10-32	6
10	322077	Splash Guard	1
11	323006	Stop, Door	1
12	100740	Bolt 5/16-18 x 1 Hex Head	2
13	107893	Shock Absorber	6
14	323224	Bracket, Corner Machine Door Lift	1
15	323305	Angle, Door Stop.	2
16	112772	Stop, Delrin Splash Baffle	2
17	100097	Screw 10-32 x 1/2 Truss Head	8

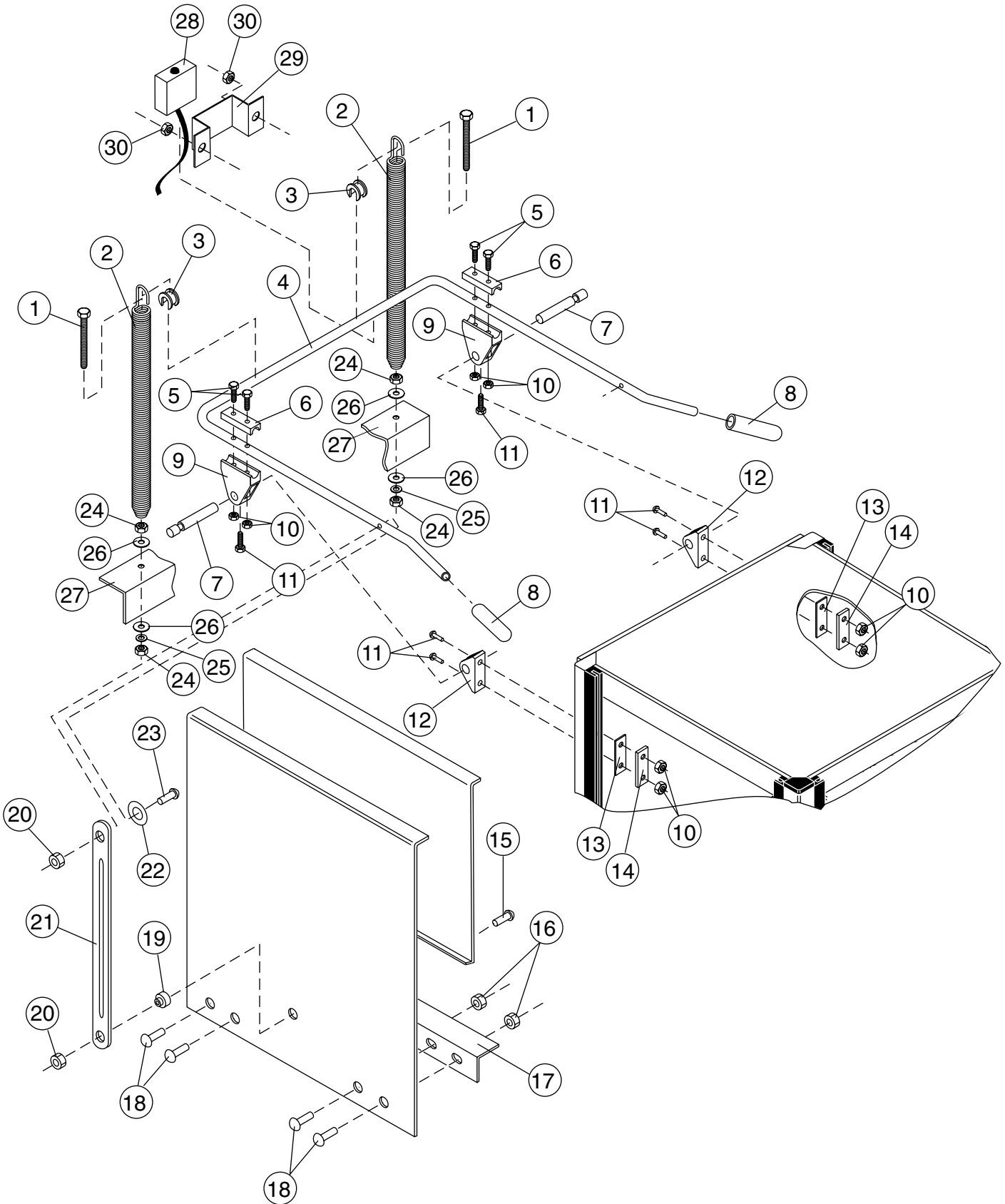

Figure 22 - D-HBT/D-H1T
Door Handle, Spring Assembly, and Safety Switch

DHB-T/DH1-T
DOOR HANDLE, SPRING ASSEMBLY, AND SAFETY SWITCH

Fig 22 Item No.	Part No.	Part Description	Qty.
1	112723	Bolt 5/16-18 x 15	2
2	108066	Spring, Extension	2
3	107397	Block, Spring Hook	2
4	112687	Door Handle (Standard Machine)	1
4	112860	Door Handle (Corner Machine)	1
5	107437	Bolt M6 x 45MM Hex Head	4
6	107396	Block, Upper Pivot	2
7	107393	Pin, Pivot	2
8	107962	Handle, Grip	2
9	107395	Block, Lower Pivot	2
10	107420	Nut, Plain M6	8
11	107436	Screw M6 x 16MM	6
12	107399	Support, Pivot Block	2
13	108368	Gasket, Backing	2
14	304811	Plate, Backing	2
15	100740	Bolt 5/16-18 x 1 Hex Head	2
16	107966	Nut, Grip 10-32 w/Nylon Insert	8
17	322077	Guard, Splash	2
18	100097	Screw 10-32 x 1/2 Truss Head	8
19	0509264	Bushing, Side Door	2
20	0509274	Nut, Acorn 5/16-18	2
21	0309167	Lift Bar, Door (Standard Machine)	2
22	322926	Lift Bar, Door (Corner Machine)	2
22	102376	Washer, Flat	2
23	104002	Bolt, 5/16-18 x 1-1/2	2
24	100154	Nut, Plain 5/16-18	4
25	106013	Washer, Lock 5/16 Split	2
26	102376	Washer, Flat	4
27	321927	Spring Anchor Bracket	1
28	112659	Hamlin Reed Switch (Standard Machine)	1
28	0509199	Switch, Door Safety (Corner Machine)	1
29	322797	Door Switch Bracket (Corner Machine)	1
29	322787	Door Switch Bracket (Standard Machine)	1

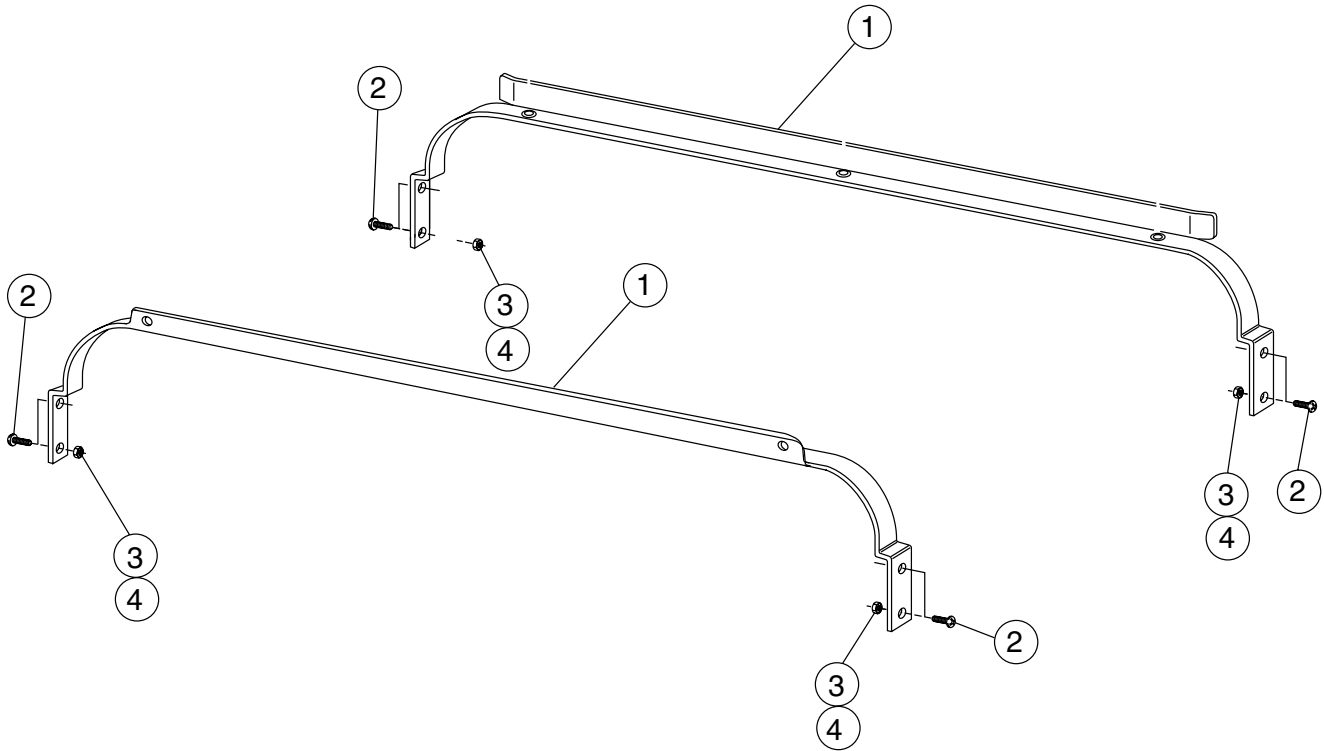

Figure 23A – D-HBT/D-H1T
Straight Track Assembly

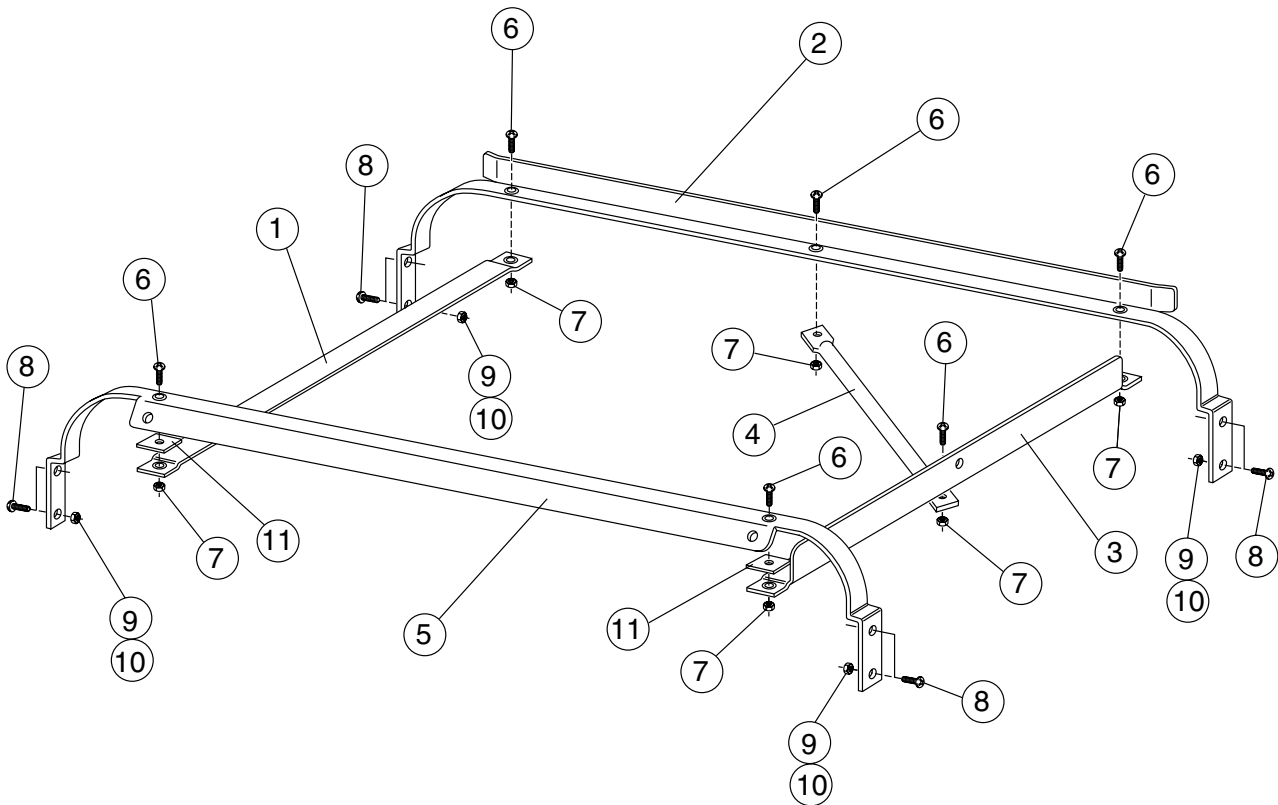

Figure 23B – D-HBT/D-H1T
Corner Track Assembly

**D-HBT/D-H1T
STRAIGHT TRACK ASSEMBLY**

Fig. 23A Item No.	Part No.	Part Description	Qty.
1	0309472	Track, Rear	1
2	100073	Bolt (1/4 -20 x 1/2 Truss Head).....	8
3	106482	Washer, Lock	8
4	100003	Nut (1/4-20 Hex Hd)	8

**D-HBT/D-H1T
CORNER TRACK ASSEMBLY**

Fig. 23B Item No.	Part No.	Part Description	Qty.
1	0309469	Guide, Right Hand	1
2	0309472	Track, Rear	1
3	0309468	Guide, Left Hand	1
4	0309470	Support, Rack	1
5	0309471	Track, Front	1
6	106727	Screw (10-32 x 5/8 Flat Hd).....	8
7	107966	Nut, Grip (10-32 w/Nylon Insert)	8
8	100073	Bolt (1/4 -20 x 1/2 Truss Head).....	8
9	106482	Washer, Lock	8
10	100003	Nut (1/4-20 Hex Hd)	8
11	0309473	Spacer	2

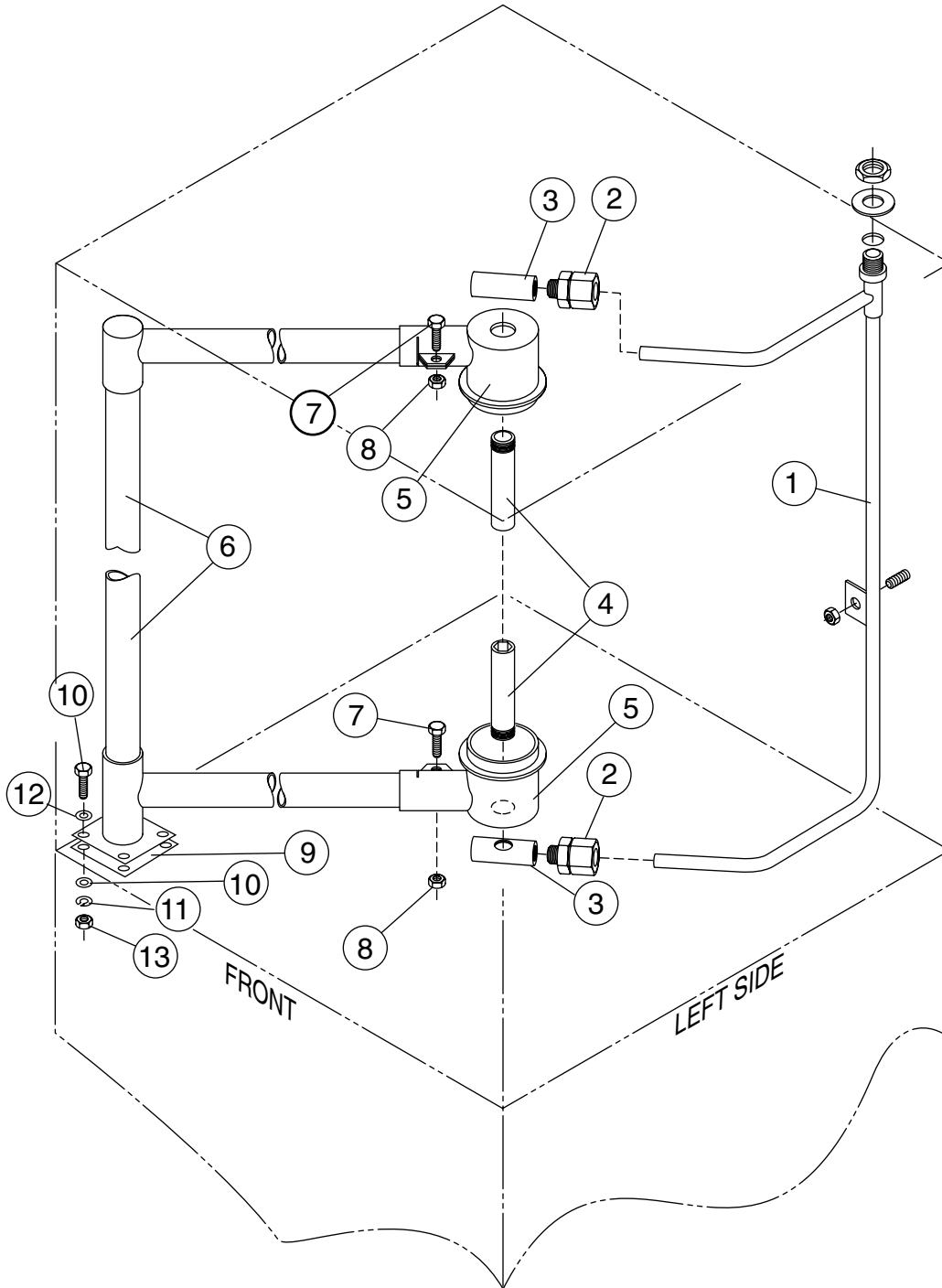

Figure 24 - D-HBT/D-H1T
Wash/Rinse Spray Piping

**D-HBT/D-H1T
WASH/RINSE SPRAY PIPING**

Fig 24 Item No.	Part No.	Part Description	Qty.
1	325632	Rinse Manifold Weldment	1
2	113027	Connector, Rinse Arm	2
3	113028	Top Rinse Arm Connector	2
4	0507445	Spindle, Wash Arm	2
5	109864	Support, Wash Arm	2
6	113252	Standpipe, Wash	1
7	100736	Bolt 1/4-20 x 3/4 Hex Head	2
8	107967	Nut, Grip 1/4-20	3
9	109854	Gasket, Standpipe Wash	1
10	100740	Bolt 5/16-18 x 1" Hex Head	4
11	106013	Washer, Lock 5/16 Split	4
12	102376	Washer, Flat	8
13	100154	Nut, Plain 5/16-18	4

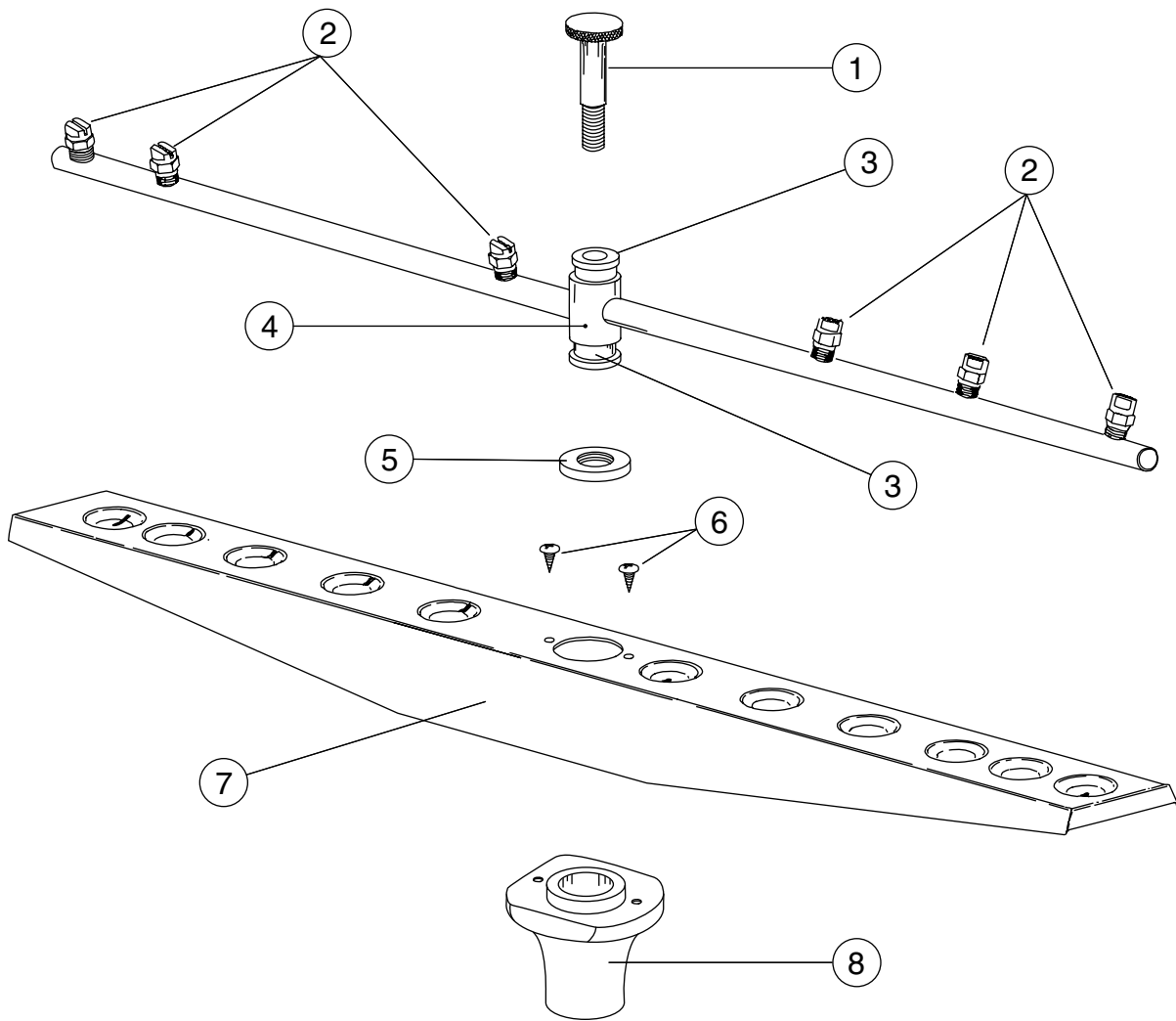

Figure 25 - D-HBT/D-H1T
Wash/Rinse Spray Arms

**D-HBT/D-H1T
WASH/RINSE SPRAY ARMS**

Fig. 25 Item No.	Part No.	Part Description	Qty.
1	0507443	Spindle, Rinse Arm	2
2	0508376	Nozzle, Rinse Arm	12
3	112164	Bearing, Rinse Arm	4
4	0707453	Rinse Arm Assy. (Includes 2 & 3)	2
5	0507444	Nut, Rinse Arm	2
6	109835	Screw (#8 x 1/2 Pan Hd)	4
7	0707452-S	Wash Arm Assy. (Includes 6 & 8)	2
8	0507446	Bearing, Wash Arm	2
—	0707450	Rinse Arm (Does not include items 2 or 3)	
—	0707456	Wash Arm (Does not include item 8)	

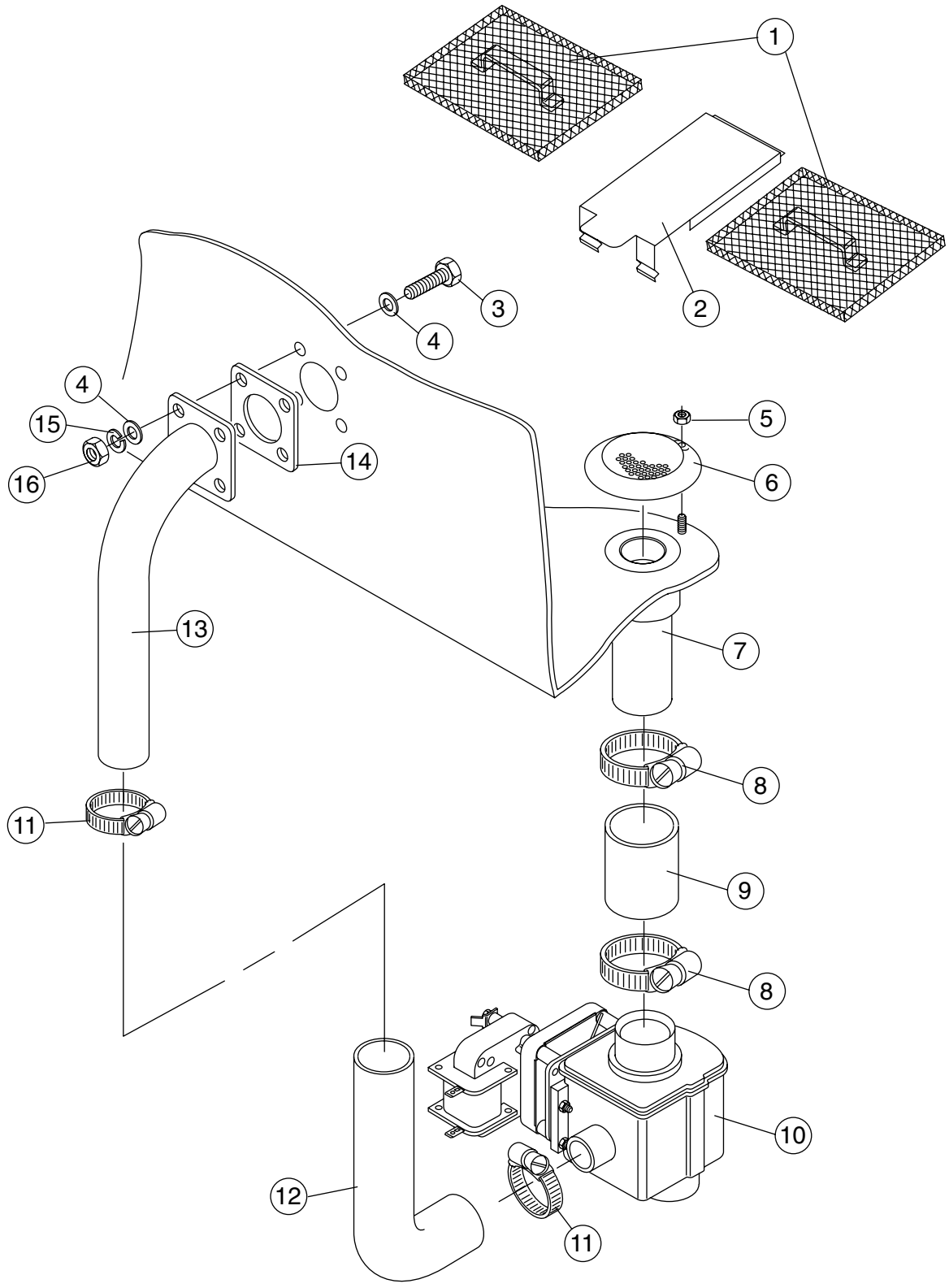

Figure 26 - D-HBT/D-H1T
Drain Assembly and Scrap Screens

**D-HBT/D-H1T
DRAIN ASSEMBLY AND SCRAP SCREENS**

Fig 26 Item No.	Part No.	Part Description	Qty.
1	305164	Screen 10"	2
2	324582	Filler Plate	1
3	100736	Bolt 1/4-20 x 3/4 Hex Head	4
4	106026	Washer, Flat	8
5	107967	Grip, Nut 1/4-20 w/Nylon Insert	1
6	304816	Strainer	1
7	205988	Connector, Electric Drain Valve	1
8	104165	Clamp, Hose	2
9	205990	Hose, Rubber	1
10	113315	Electric Drain Valve (after S/N D2964)	1
10	900830	Kit, Drain Valve (from S/N 01848 thru D2963)	A/R
11	107340	Hose Clamp	2
12	113048	Overflow Hose	1
13	324573	Overflow Flange Weldment	1
14	113047	Gasket, Drain Flange	1
15	106482	Washer, Lock 1/4 Split	4
16	100003	Nut Plain 1/4-20 SST	4

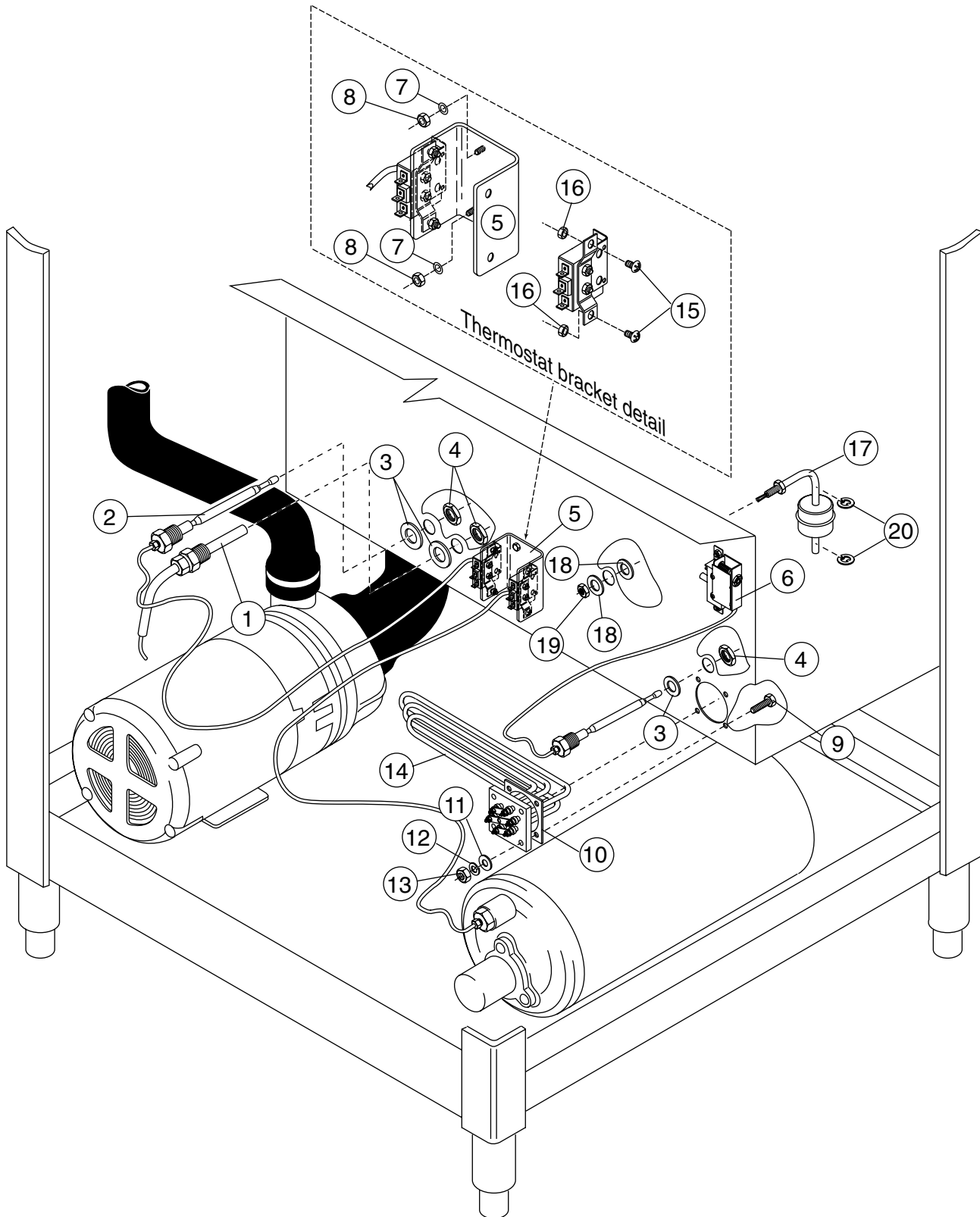

Figure 27 - D-HBT/D-H1T
Wash Tank Heat and Thermostats

**D-HBT/D-H1T
WASH TANK HEAT AND THERMOSTATS**

Fig. 27 Item No.	Part No.	Part Description	Qty.
1	113622	Thermometer 4 Ft. Gas Filled (Replaces 108391)	1
2	109069	Thermostat W/Cap 110-220°F	1
3	201041	Washer	3
4	201029	Nut, Lock 1/2"	3
5	322076	Dual Thermostat Bracket	1
6	110561	Thermostat, Fixed High Limit	1
7	106482	Washer, Lock 1/4 Split SST	4
8	100003	Nut, Plain 1/4-20 SST	4
9	100740	Bolt 5/16-18 x 1 Hex Head	4
10	108345	Gasket 3 x 3 x 1/8 2"	1
11	102376	Washer 5/16 x 3/4 x 1/16	8
12	106013	Washer, Lock 5/16 Split	4
13	100154	Nut, Plain 5/16-18 SST	4
14	0509637	Heater 3KW 115V/1PH	1
	0509185	Heater 3KW 208-240/380-415V 1/3PH	1
	0509373	Heater 3KW 460V/3PH	1
	0509372	Heater 3KW 575V/3PH	1
15	100007	Screw 10-32 x 3/8 Truss Head	4
16	107966	Nut, Grip 10-32 W/Nylon Insert	4
17	111092	Float Switch	1
18	104882	Washer	2
19	107089	Nut, Jam, 1/2-13	1
20	111151	C-Clip Float Switch	2

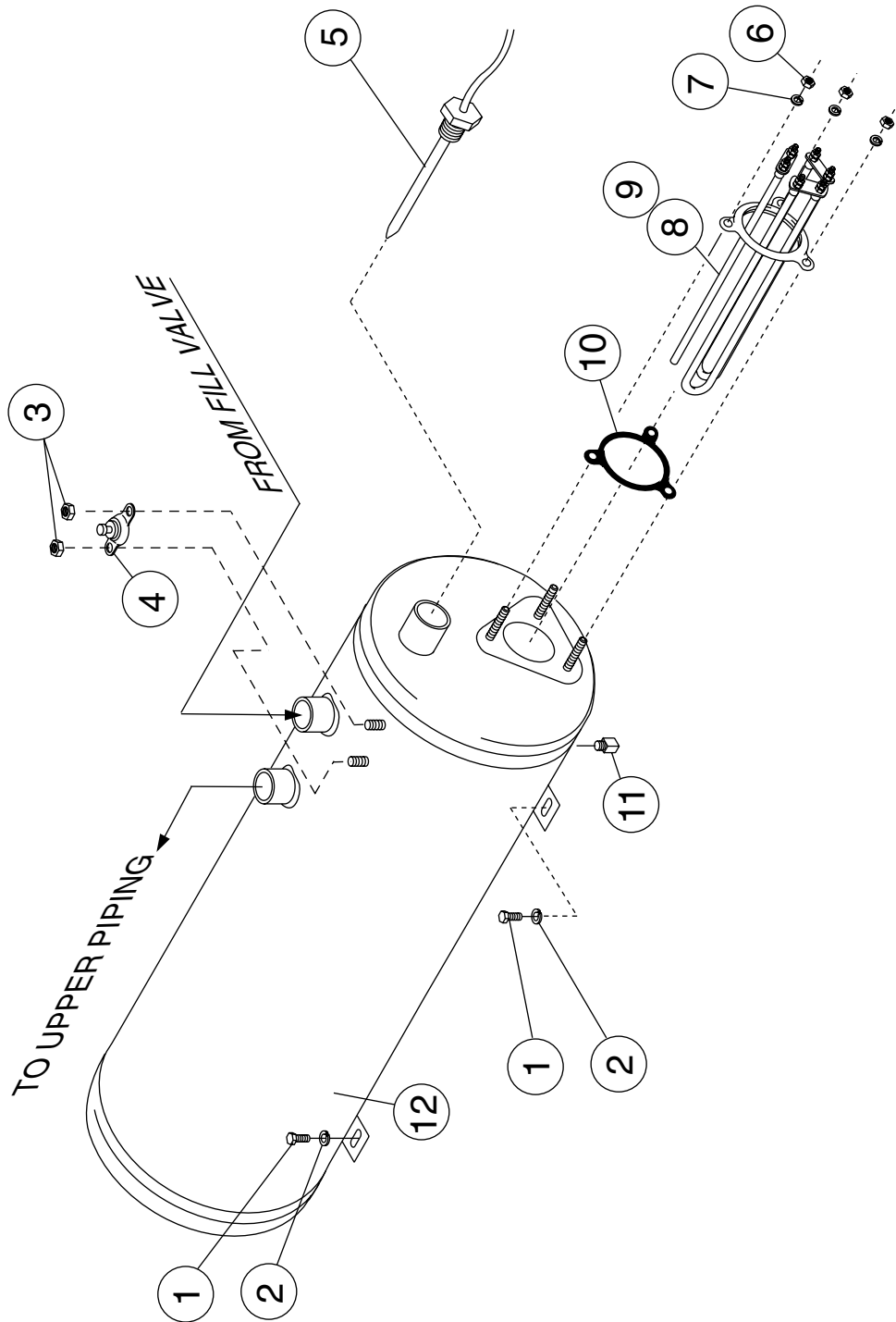

Figure 28 - D-HBT Only
Electric Booster and Thermostats

D-HBT ONLY
ELECTRIC BOOSTER AND THERMOSTATS

Fig. 28 Item No.	Part No.	Part Description	Qty.
1	100740	Bolt 5/16-18 x 1 Hex Head	2
2	102376	Washer, Flat 5/16 x 3/4 x 1/16	2
3	108954	Nut, Grip 6-32 W/Insert	2
4	110562	Thermostat, High Limit	1
	110563	Compound, Heat Sink	A/R
5	109069	Thermostat, Booster	1
6	100003	Nut, Plain 1/4-20 SST	3
7	106482	Washer, Lock 1/4 Split	5
8	111334	Heater 9KW 208-240/380-415V, 40° Rise (1 & 3 phase)	1
	108579	Heater 9KW 480V, 40° Rise (3 phase only)	1
	111122	Heater 9KW 575V, 40° Rise (3 phase only)	1
9	111266	Heater 18KW 208-240/380-415V, 70° Rise (1 & 3 phase)	1
	111267	Heater 18KW 480V, 70° Rise (3 phase only)	1
	111600	Heater 18KW 575V, 70° Rise (3 phase only)	1
10	109985	Seal, Electric Heater	1
11	100210	Plug 1/8 SST	1
12	0509042	Tank, Booster	1

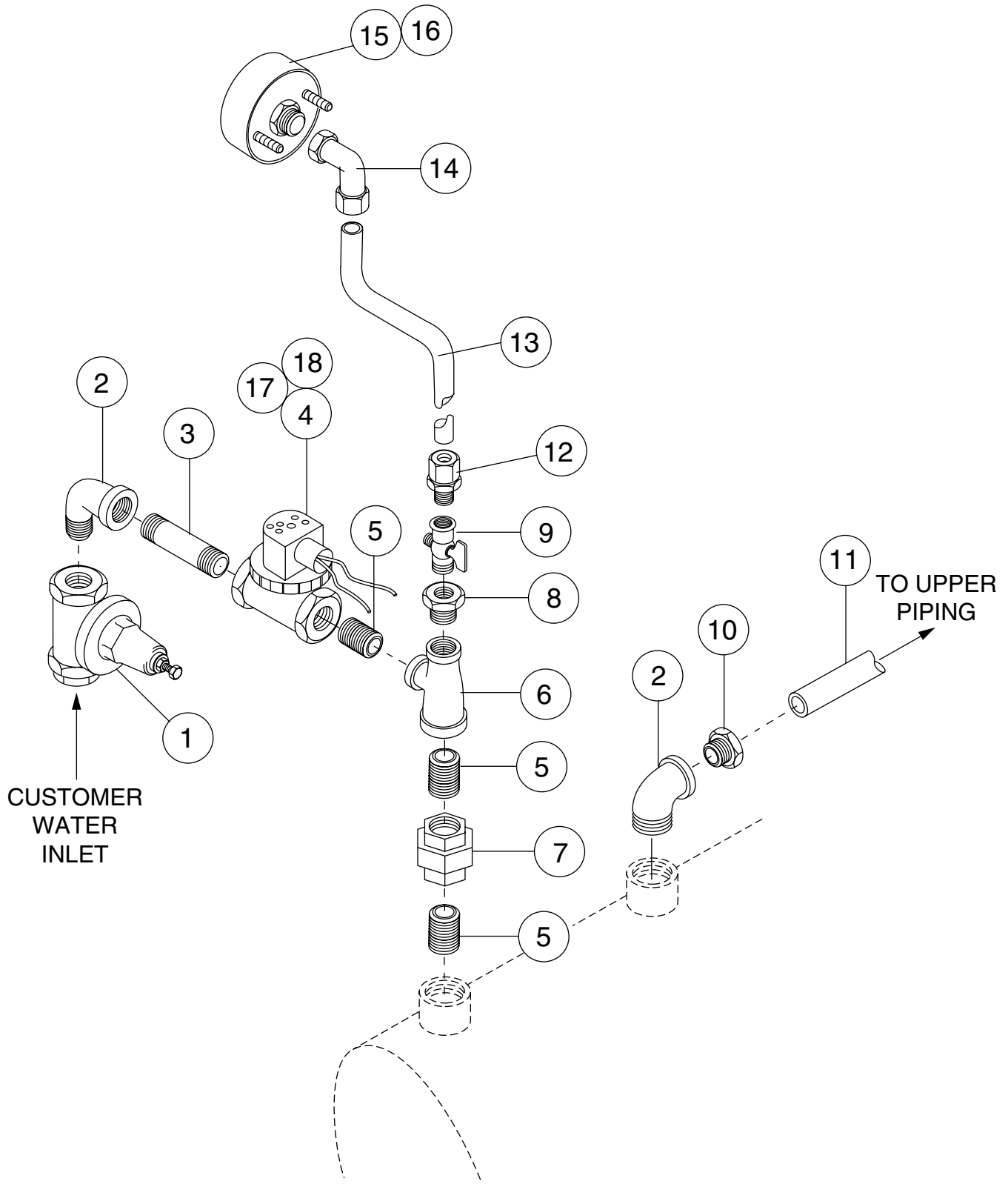

Figure 29 - D-HBT Only
Lower Fill Piping Assembly

**D-HBT ONLY
LOWER FILL PIPING ASSEMBLY**

Fig. 29 Item No.	Part No.	Part Description	Qty.
1	112387	Line Strainer/PRV Combo.....	1
2	102444	Street Ell 3/4" NPT Brass.....	2
3	102651	Nipple 3/4" x 2" Brass.....	1
4	111437	Valve 3/4" NPT Hot Water.....	1
5	100184	Nipple 3/4" NPT.....	3
6	102525	Tee 3/4" x 1/2" x 3/4" Brass.....	1
7	100571	Union 3/4" NPT Brass.....	1
8	102388	Bushing Reducer 1/2" x 1/4" Brass.....	1
9	112437	Valve, Needle 1/4".....	1
10	109879	Fitting, Compress, 3/4 NPT x 7/8 OD.....	1
11	205824	Final Rinse Tube.....	1
12	107065	Connector, Male 1/4" OD x 1/4 NPT.....	1
13	107928	Tubing, High Density.....	3ft.
14	111100	Elbow, Female 1/4" OD x 1/8 NPT.....	1
15	109812	Gauge, Pressure 0-100 PSI.....	1
16	109816	Overlay, Gauge 20-30 PSI.....	1
17	108516	Coil, Solenoid Valve (120V).....	1
18	109903	Kit, Repair, 3/4" Solenoid Valve.....	1

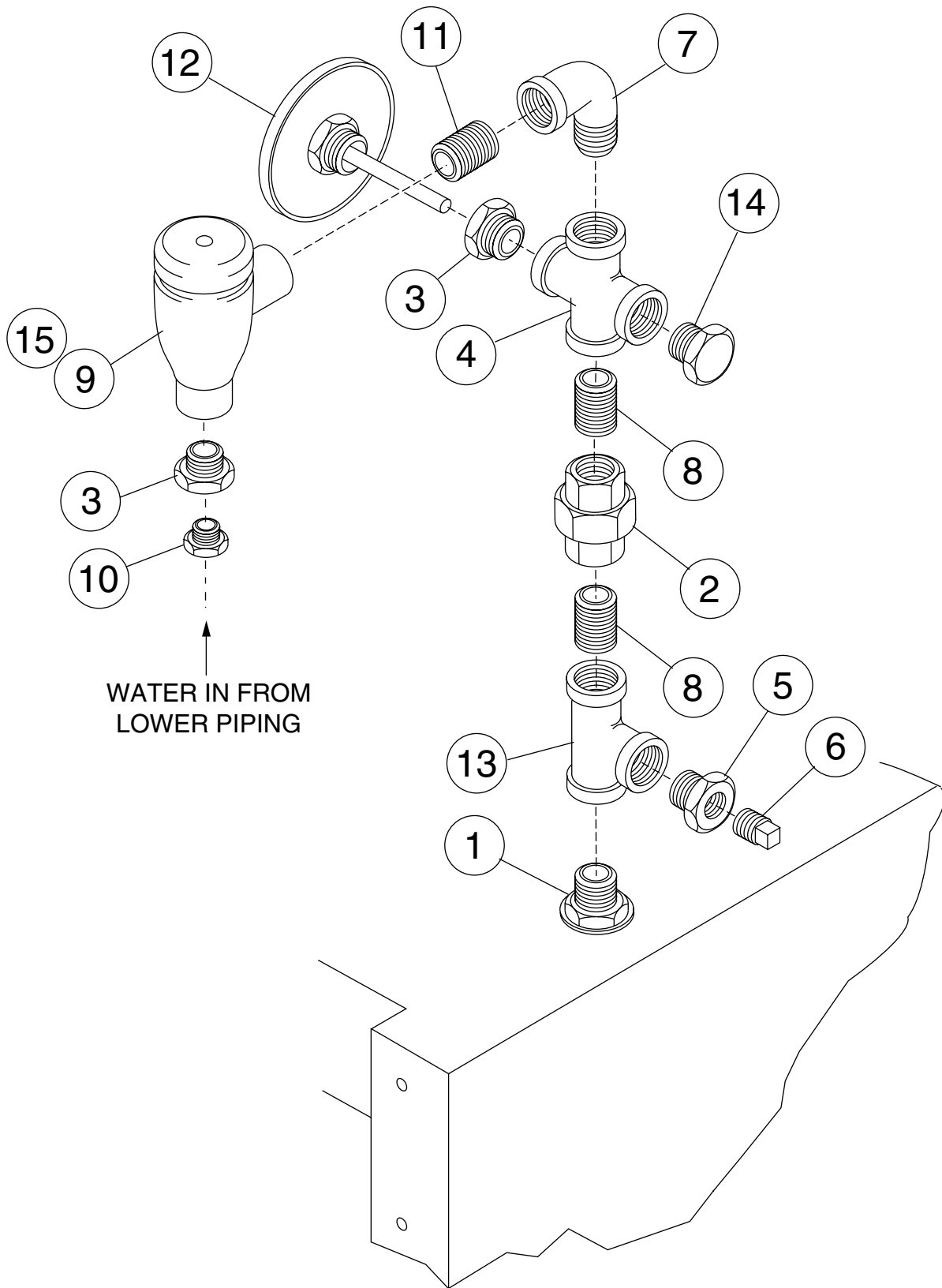

Figure 30 - D-HBT/D-H1T
Upper Fill Piping Assembly

**D-HBT/D-H1T
UPPER FILL PIPING ASSEMBLY**

Fig 30 Item No.	Part No.	Part Description	Qty.
1	100156	Locknut, 3/4" NPT Brass	1
2	100571	Union 3/4" NPT Brass	1
3	102392	Bushing, Reducing 3/4" NPT x 1/2" Brass	2
4	100599	Cross., 3/4 NPT Brass	1
5	108181	Bushing, Reducing 3/4 x 1/4 NPT Plastic	1
6	107463	Plug, 1/4 NPT Plastic	1
7	102444	Elbow, Street 3/4 NPT x 90° Brass	1
8	100184	Nipple, Close 3/4 NPT	2
9	104429	Vacuum Breaker 3/4" NPT (Prior to S/N D3290)	1
9	113222	Vacuum Breaker 3/4" NPT (After S/N D3291)	1
10	109925	Compression Fitting 1/2 NPT x 5/8 OD	1
11	102489	Nipple, 3/4" NPT x 2-1/2" Brass	1
12	104682	Thermometer 1/2" NPT	1
13	102521	Tee 3/4" NPT	1
14	102505	Plug 3/4 NPT Brass	1
15	108351	Repair Kit 3/4" Vacuum Breaker (Prior to S/N D3290)	1
15	113223	Repair Kit 3/4" Vacuum Breaker (After S/N D3291)	1

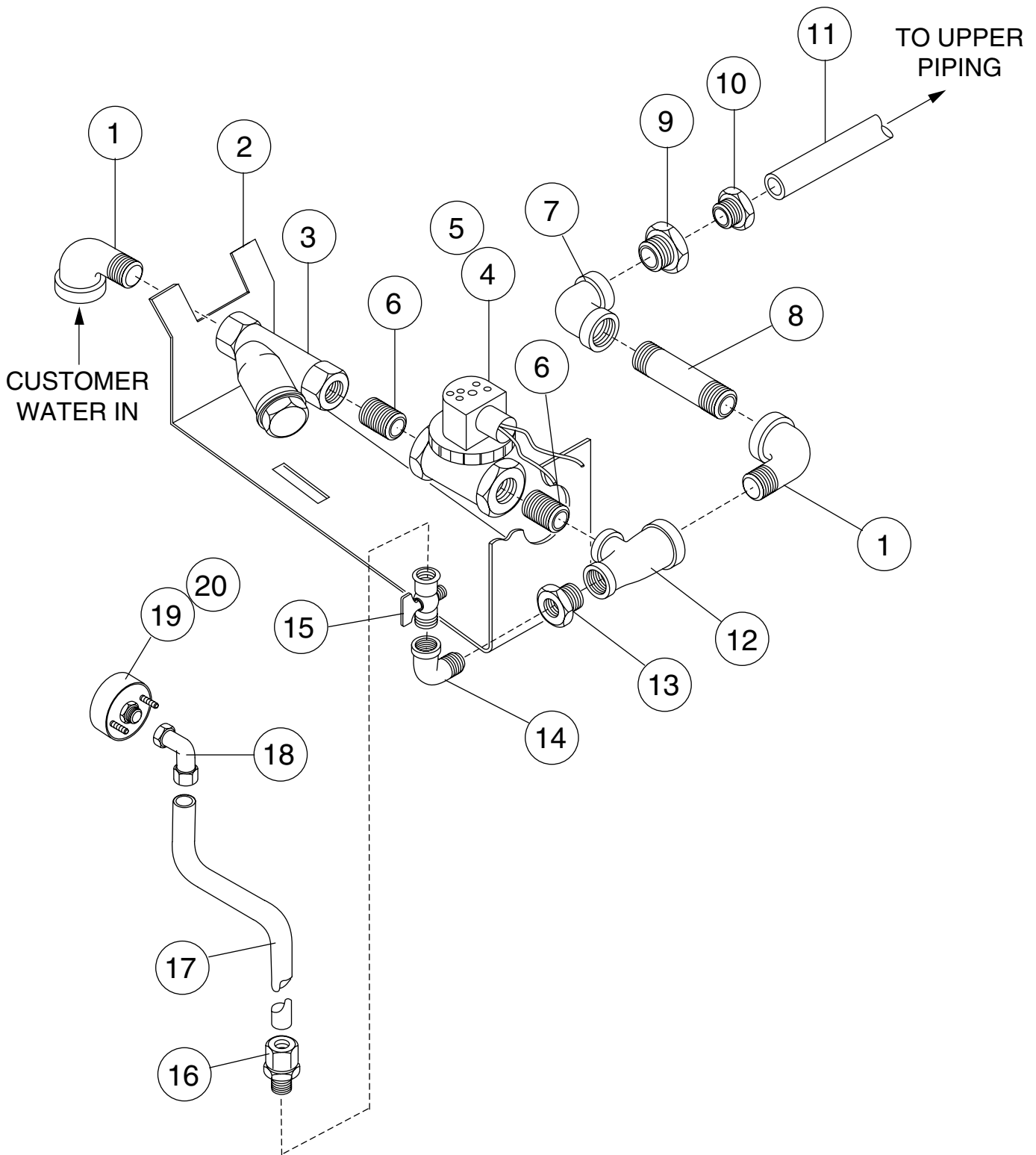

Figure 31 - D-H1T Only
Lower Fill Piping Assembly

**D-HBT/D-H1T
LOWER FILL PIPING ASSEMBLY**

Fig 31 Item No.	Part No.	Part Description	Qty.
1	102444	Street Ell 3/4" NPT Brass	2
2	0309340	Plumbing Support Bracket	1
3	110768	Line Strainer 3/4" Brass	1
4	111437	Valve 3/4" NPT Hot Water	1
5	109903	Repair Kit, 3/4" Solenoid Valve	1
6	100184	Nipple, Close 3/4" NPT Brass	2
7	102442	Elbow 3/4" NPT Brass	1
8	102470	Nipple, 3/4"NPT x 3" Brass	1
9	102392	Bushing, Reducing 3/4 x 1/2 NPT Brass	1
10	109925	Compression Fitting 1/2 NPT x 5/8 OD	1
11	205824	Tube 1/2 Copper Formed	1
12	102525	Tee Reduce, 3/4 x 1/2 x 3/4 NPT Brass	1
13	102388	Bushing, Reducing 1/2 x 1/4 NPT Brass	1
14	101261	Street Ell 1/4" NPT Brass	1
15	112437	Needle, Valve 1/4" MPT Brass	1
16	107065	Adapter, 1/4"OD x 1/4 MPT Plastic	1
17	107928	Tubing, High Density	3ft
18	111100	Elbow, Female 1/4" OD x 1/8 NPT	1
19	109812	Gauge, Pressure 0-100 PSI	1
20	109765	Overlay, Gauge	1

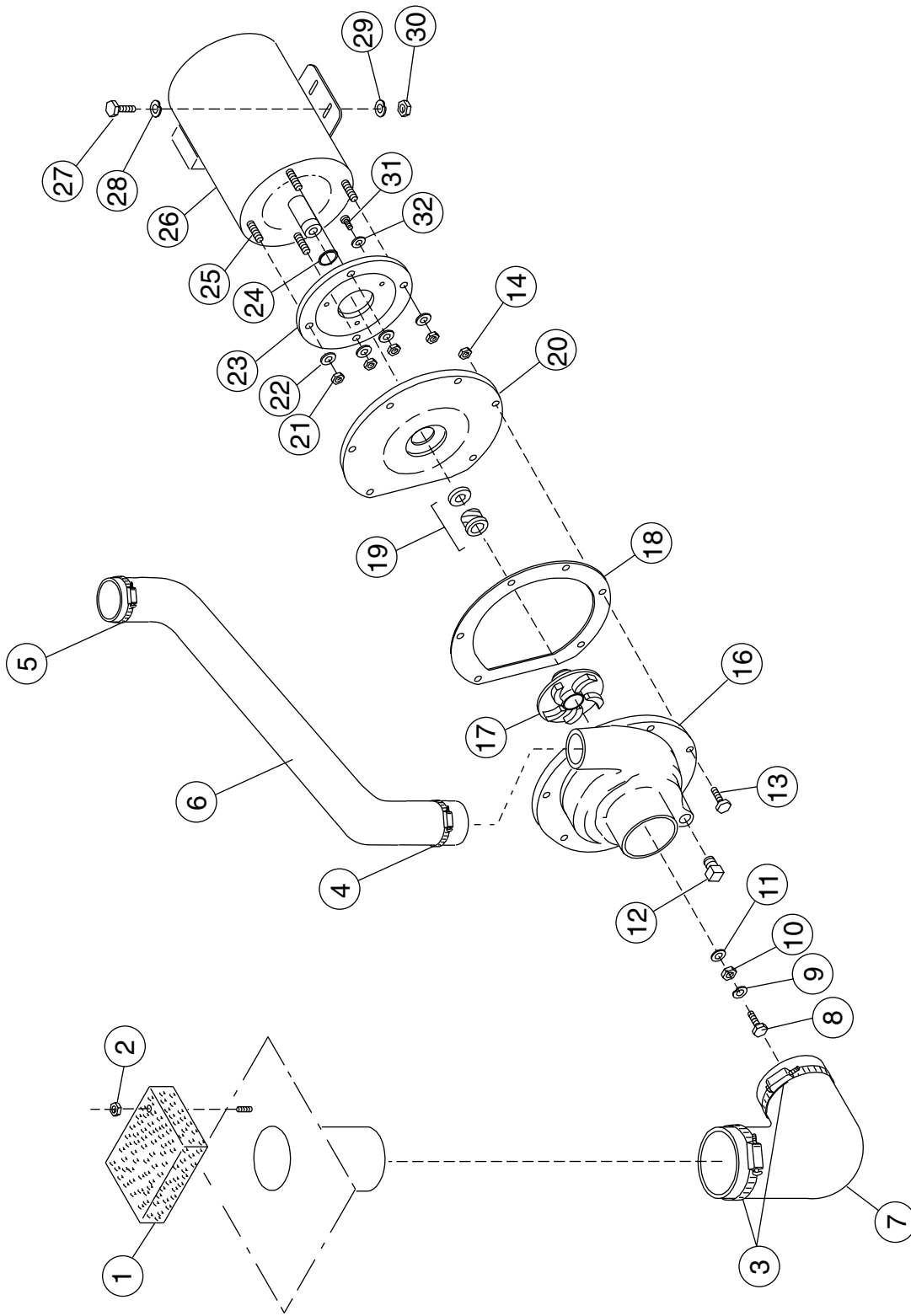

Figure 32 - D-HBT/D-H1T
Pump Assembly

**D-HBT/D-H1T
PUMP ASSEMBLY**

Fig 32 Item No.	Part No.	Part Description	Qty.
1	324580	Strainer	1
2	107966	Nut, Grip 10-32 w/Nylon Insert	1
3	104203	Clamp, Hose	2
4	104165	Clamp, Hose	1
5	107340	Clamp, Hose	1
6	112383	Hose Pump, Discharge	1
7	0508515	Hose, Suction	1
8	100734	Bolt 1/4-20 x 1/2" Hex Head.....	1
9	106482	Washer, Lock 1/4" Split.....	1
10	110247	Nut, Hex Jam 7/16-20	1
11	110248	Washer, Flat	1
12	107463	Plug 1/4"	1
13	107137	Bolt 10-32 x 7/8 Hex Head	11
14	100194	Nut, Grip (10-32)	11
15	0501505	Washer, Lock Int SST #8 (Not Shown)	11
16	109651	Volute	1
17	113248	Impeller, 1.4HP SST	1
18	109653	Gasket, O-ring	1
19	111111	Pump Seal.....	1
20	109649	Flange Assembly 1HP	1
21	107690	Nut, Jam 3/8-16	4
22	106407	Washer, Lock 3/8" Split.....	4
23	109648	Backing Plate	1
24	109654	Pump Slinger Washer	1
25	110734	Stud 3/8-16 x 1-3/8	4
26	110422	Motor 2HP (208-240V/460V/60/3).....	1
26	110421	Motor 2HP (115V/208-240V/60/1).....	1
26	112163	Motor 1.4HP (115V/208-240V/50/1)	1
26	0507708	Motor 1.4HP (575V/60/3)	1
27	100739	Bolt 5/16-18 x 3/4 Hex Head	4
28	102376	Washer, Flat 5/16	4
29	106013	Washer, Lock 5/16-18 SST	4
30	100142	Nut, Grip 5/16-18	4
31	100754	Screw, Flat 10-32 x 1/2	4
32	110270	Washer, Countersunk SST	4
—	109645	Kit, Pump (Includes 16, 18, 20, 23, 24)	1
—	452281	Pump, Motor Assembly Complete 2HP (208-240V/460V/60/3PH)	1
—	452282	Pump, Motor Assembly Complete 2HP (115V/208-240V/60/1PH)	1
—	452283	Pump, Motor Assembly Complete 2HP (575V/60/3PH)	1

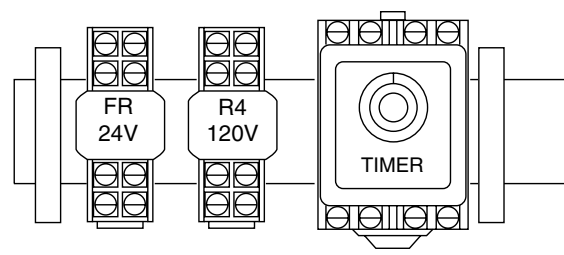
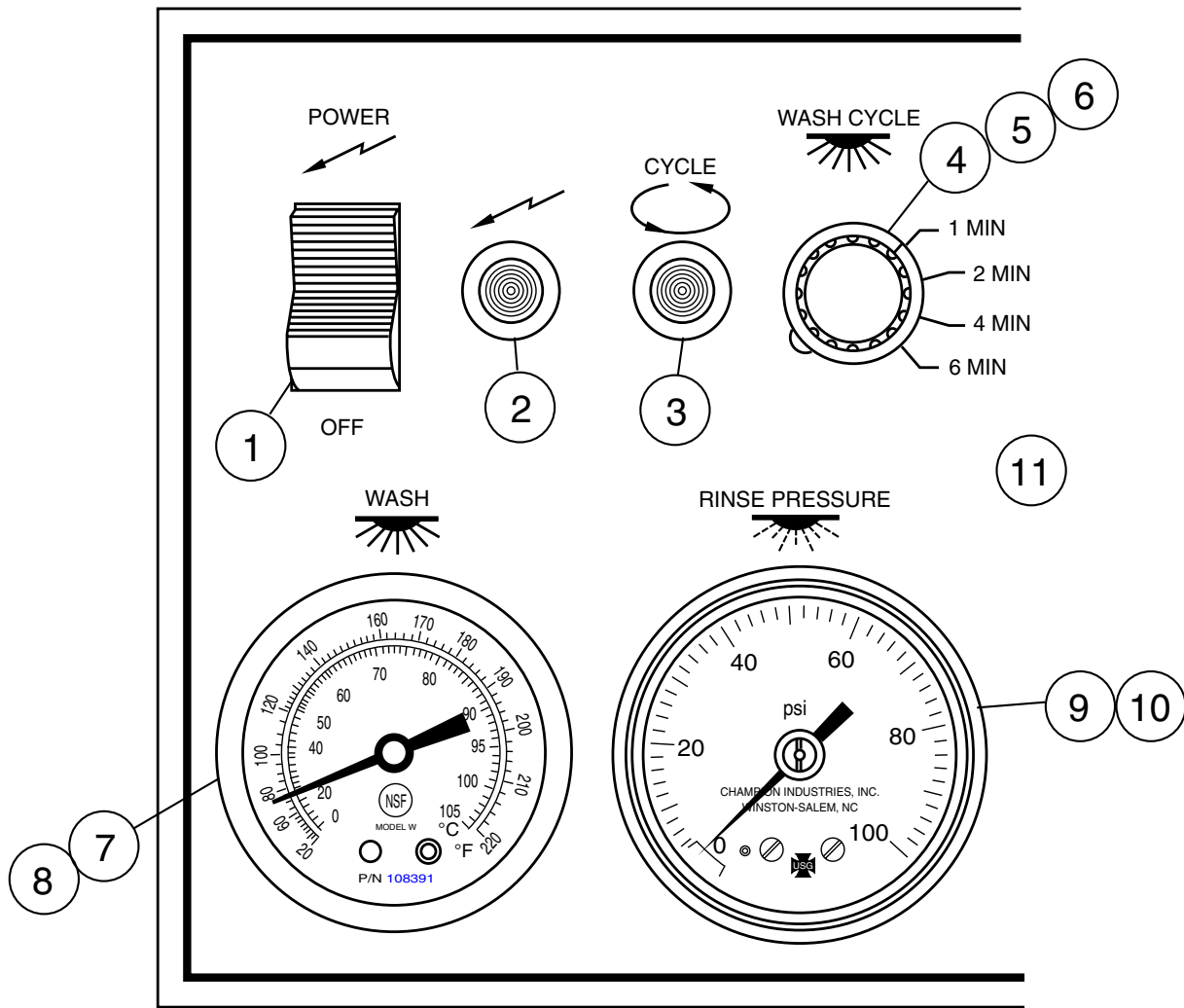
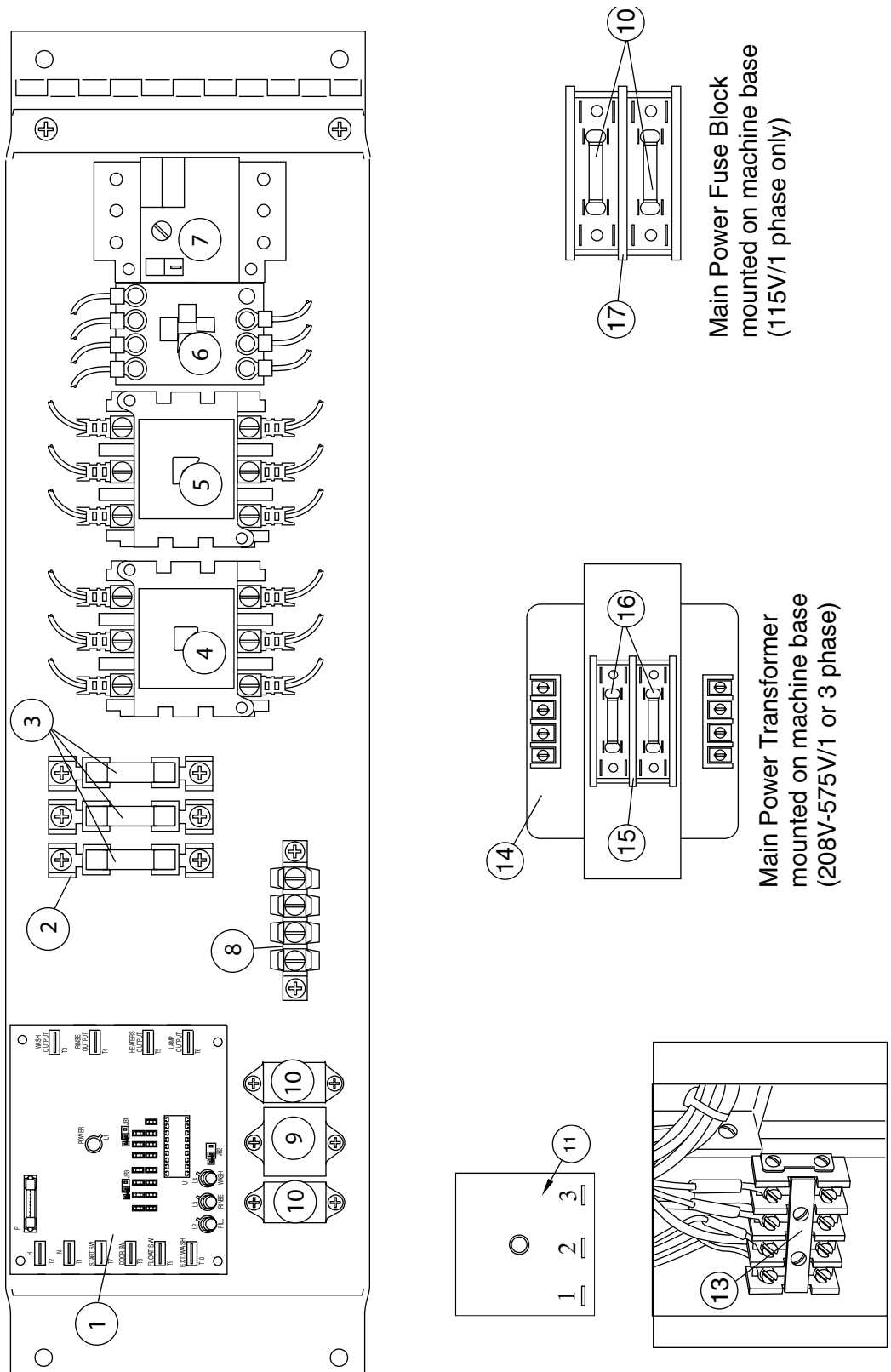

Figure 33 - D-HBT/D-H1T
Control Panel and Gauges

**D-HBT/D-H1T
CONTROL PANEL AND GAUGES**

Fig 33 Item No.	Part No.	Part Description	Qty.
1	0501361	Switch, On-Off	1
2	112390	Lite, Red (Power)	1
3	112391	Lite, Amber (In-Cycle)	1
4	113054	Switch, Time Select (4 Position)	1
5	113055	Contact Block (NO)	1
6	113056	Contact Block (NO)	2
7	112086	Overlay, Wash 150°F	1
8	113622	Thermometer, 4 Ft. Gas Filled (Replaces 108391)	1
9	109812	Gauge, Pressure 0-100 PSI	1
10	109756	Overlay, 20-30 PSI	1
11	113051	Label, Panel Overlay DH-T/TC	1



Main Power Fuse Block
mounted on machine base
(115V/1 phase only)

Main Power Transformer
mounted on machine base
(208V-575V/1 or 3 phase)

Figure 34 - D-HBT/D-H1T
Control Cabinet

**D-HBT/D-H1T
CONTROL CABINET**

Fig 34 Item No.	Part No.	Part Description	Qty.
1	900911	Kit* DM Board & Instructions	1
2	106925	Block, Fuse (30A, 3 Pole)	1
3	100913	Fuse, 10A (DHB-T) 208-240/380-415/3	3
3	100906	Fuse, 5A (DHB-T) 480V/3	3
3	100913	Fuse, 10A (DH1-T) 208-240/380-415/3	3
3	100906	Fuse, 5A (DH1-T) 480V/3	3
3	0508676	Fuse, 30A (DH1-T) 115V/1	2
3	100913	Fuse, 20A (DH1-T) 208V/1	2
3	100922	Fuse, 20A (DHB-T) 208V/1	3
4	111904	Contactor, Booster Heater (40A, 3 Pole) (All Models)	1
5	111904	Contactor, Wash Tank Heater (40A, 3 Pole) (All Models)	1
6	108122	Contactor, 2HP Wash Motor (12A, 3 Pole) (All Models)	1
7	112691	Overload, Motor 2HP Wash (All Models) 208-240V/3	1
7	110805	Starter Mtr OL GV2-M08 w/Aux 2HP Wash (All Models) 480V/3 ..	1
7	110805	Starter Mtr OL GV2-M08 w/Aux 2HP Wash (All Models) 380-415V/3 ..	1
7	112692	Overload, Motor 2HP Wash (All Models) 575V/3	1
7	111632	Overload, Motor 2HP Wash (DH1-T) 115V/1	1
7	111632	Overload, Motor 2HP Wash (DH1-T) 208-240V/1	1
8	107366	Board, Terminal	1
9	112382	Relay (3PDT, 10A, 120VAC coil)	1
10	111068	Relay (2PDT, 10A, 120VAC coil)	2
11	113314	Timer, Infintec 600 Second (Drain Timer)	1
12	0509564	Label, Chemical Connections (Not Shown)	1
13	111833	Block, Terminal (3 Pole) (Main Power)	1
14	109064	Transformer (208-240/1 & 3, 480/3)	1
15	112424	Kit, Fuse Block (2 Pole) (208-240V/1-3PH, 380-415V/3PH, 480V/3PH, 575V/3PH)	1
16	112484	Fuse, 1.5A, 600V (ATDR) 208-240V/1-3PH	2
16	112483	Fuse, 1.8A, 600V (ATDR) 380-415V/3PH	2
16	112887	Fuse, .5A, 600V (ATDR) 480V/3PH	2
16	112887	Fuse, .5A, 600V (ATDR) 575V/3PH	2
17	106402	Block, Fuse (2 Pole) (115V Only)	1
18	107289	Fuse, 2.5A, 250V (ATDR) 115V Only	2
—	103310	Wire Lug, Ground (Not Shown)	1

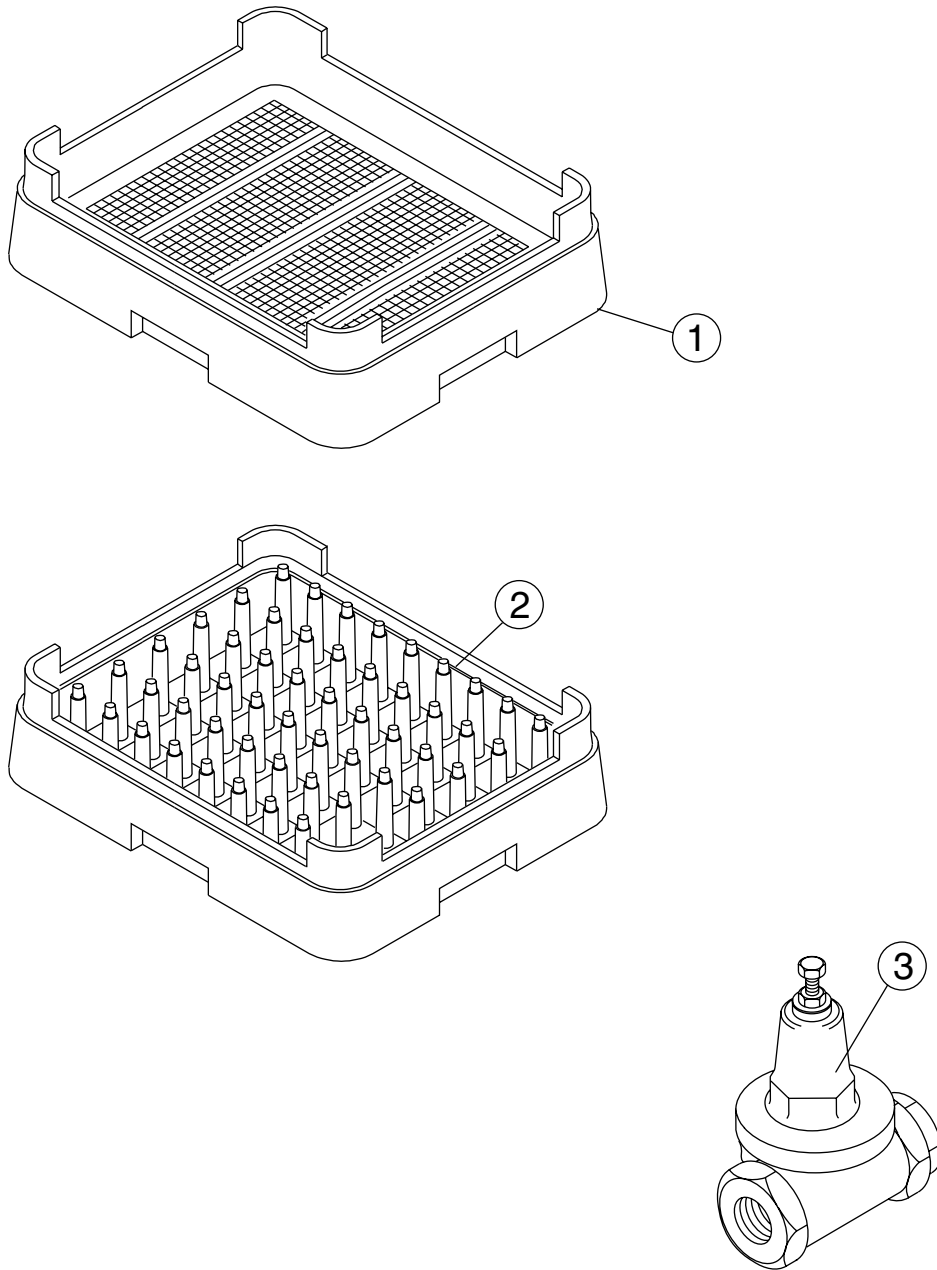

**Figure 35 -
Dishracks and PRV**

DISHRACKS AND PRV

Fig. 35 Item No.	Part No.	Part Description	Qty.
1	101273	Rack (Flat Bottom)	1
2	101285	Rack (Peg)	1
3	112387	Line Strainer/PRV Combo	1

APPENDIX A

DRAIN VALVE/TIMER CIRCUIT

Models D and D-H1T use a drain circuit consisting of a 3cr relay, 10 minute timer, and a drain valve.

OPERATION:

- 1) When the power switch is pushed to the OFF position, the 3CR relay coil is then energized, closing the 3CR contacts.
- 2) Drain timer now is powered from the 3CR relay, which opens the drain valve for ten (10) minutes.
- 3) When the timer times out (10 minutes), the drain valve closes and machine has completed it's drain cycle.

NOTE: Flip the power switch on the machine to ON then OFF position to open the drain for an additional drain cycle. Repeat this step as necessary.

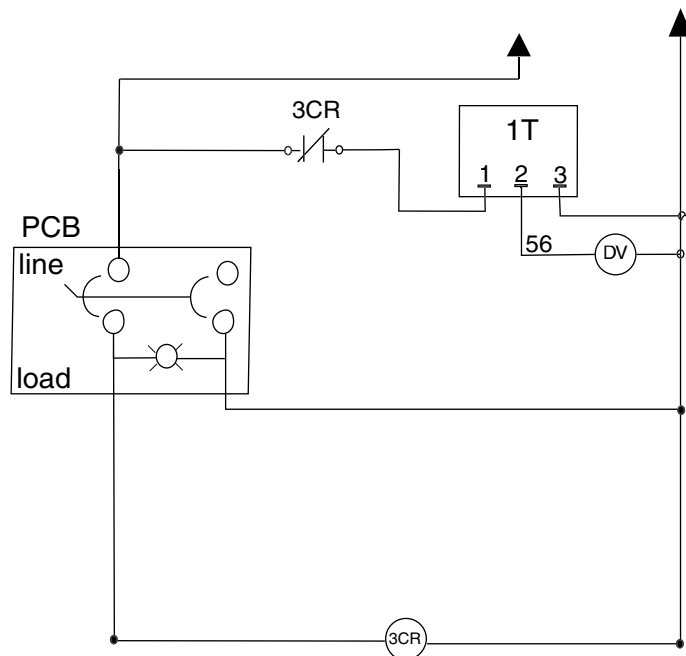
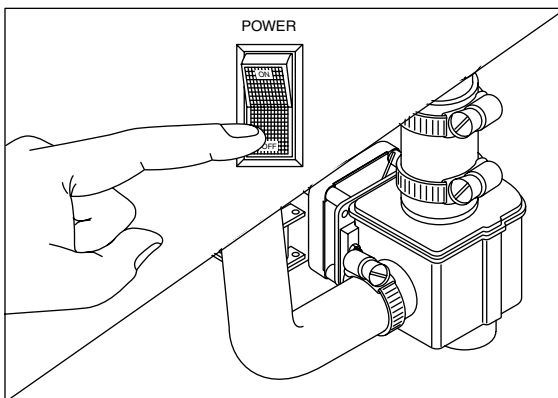

ELECTRICAL SCHEMATICS

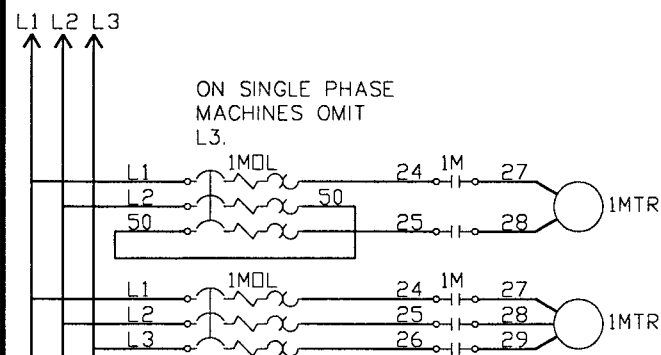

PER LOCAL ELECTRICAL CODE

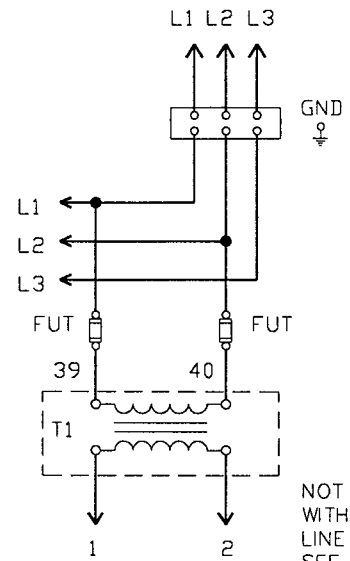

NOT USED WITH 115V LINE SUPPLY SEE NOTE 1

NOTE 1: IF SUPPLY IS 115V T1 IS NOT USED. WIRES #1 AND #2 ARE CONNECTED TO THE FUSE BLOCK.

NOTE 2: NOT USED ON CORNER MACHINES.

NOTE 3: THE KW RATING OF THE ELEMENT IS DEPENDENT UPON THE DEGREE RISE OF THE SYSTEM. SINGLE PHASE MACHINES WITH BOOSTERS ARE 40° RISE ONLY AND REQUIRE 9kW ELEMENTS. A 40° RISE THREE PHASE SYSTEM REQUIRES A 9kW ELEMENT. A 70° RISE THREE PHASE SYSTEM REQUIRES AN 18kW ELEMENT.

ELECTRIC TANK HEAT

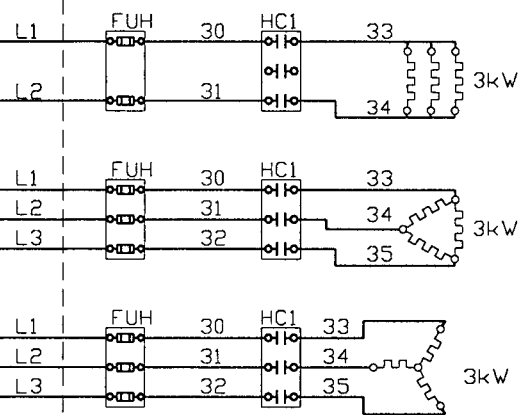

ELECTRIC BOOSTER HEAT IF USED (SEE NOTE 3)

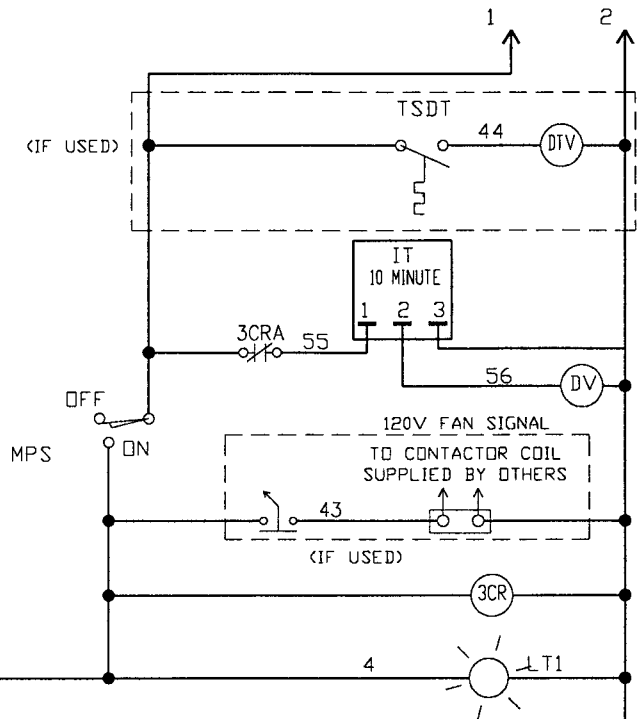
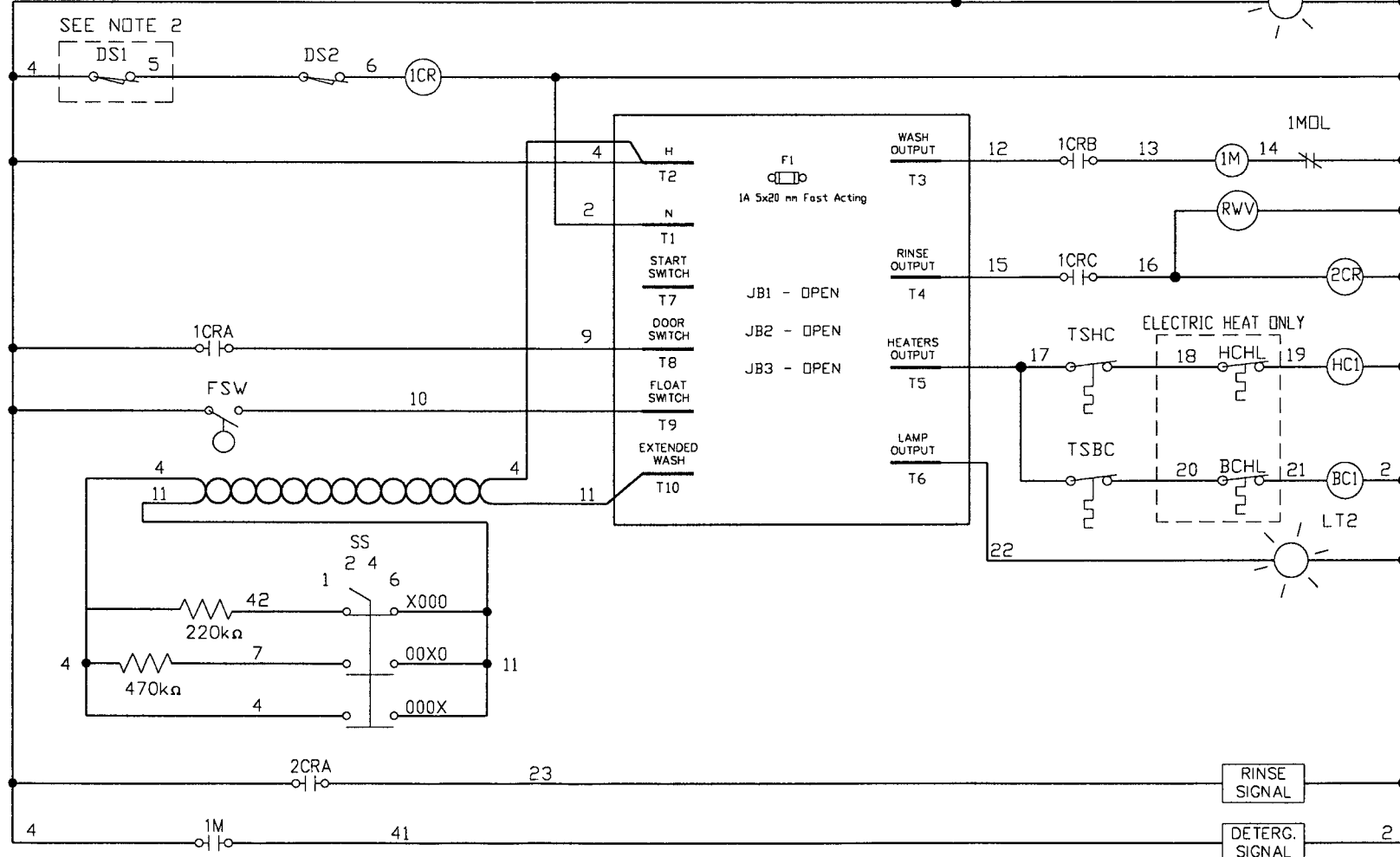
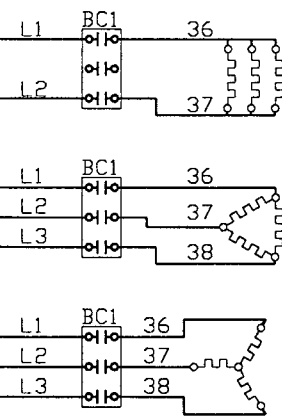

1CR	DOOR SWITCH RELAY
2CR	RINSE AID SIGNAL RELAY
3CR	POWER ON RELAY
1M	WASH MOTOR CONTACTOR
1MOL	WASH MOTOR OVERLOAD
1MTR	WASH MOTOR
BC1	BOOSTER TANK CONTACTOR OR STEAM VALVE
BCHL	BOOSTER TANK HIGH LIMIT
DS1	DOOR SAFETY SWITCH, FRONT DOOR
DS2	DOOR SAFETY SWITCH, SIDE DOORS
DTV	DRAIN TEMPERING VALVE
DV	DRAIN VALVE
F1	TIMER BOARD FUSE
FSW	FLOAT SWITCH
FUH	TANK HEAT FUSES
FUT	TRANSFORMER FUSES
HC1	TANK HEAT CONTACTOR OR STEAM VALVE
HCHL	TANK HEAT HIGH LIMIT
IT	INTERVAL TIMER, 10 MINUTE
JB1	RINSE TIME SELECT JUMPER
JB2	CYCLE SELECT JUMPER
JB3	CYCLE SELECT JUMPER
LT1	POWER ON LIGHT
LT2	CYCLE LIGHT
MPS	MAIN POWER SWITCH
RWV	RINSE WATER VALVE
SS	CYCLE TIME SELECTOR SWITCH
T1	LINE:120V TRANSFORMER
TSBC	BOOSTER TANK THERMOSTAT
TSDT	DRAIN TEMPERING THERMOSTAT
TSHC	WASH TANK THERMOSTAT

TO TEST INPUTS T8 AND T9 A METER CAPABLE OF READING DC VOLTAGES MUST BE USED.
 1.) SET METER TO READ DC VOLTAGE
 2.) PLACE BLACK LEAD TO T2
 3.) PLACE RED LEAD TO TERMINAL BEING TESTED
 i.e. PLACE RED LEAD TO T8 TO TEST DOOR SW.
 4.) AN OPEN SWITCH WILL READ 4.7-5.3VDC
 A CLOSED SWITCH WILL READ 0-1VDC

(IF USED)

DIAGRAM STATE
 POWER OFF
 DOORS CLOSED
 TANKS EMPTY
 END OF CYCLE

CUSTOMER TO SUPPLY RATED VOLTAGE/PHASE/Hz, AS SPECIFIED PER ORDER TO DISCONNECT SWITCH. ALL POWER SUPPLIED TO EACH CONNECTION POINT MUST COMPLY WITH ALL LOCAL ELECTRIC CODES.			
DR. BY	J. NEWTON	SCALE	NONE
DATE	6MAY99	SHEET	1 OF 1

REV.	DESCRIPTION	DATE	BY
A	ADDED 1 MINUTE CYCLE	4JUNE99	JCN
B	ADDED OPTIONAL VENT SWITCH CIRCUITRY	9SEPT99	JCN
C	ADDED OPTIONAL DRAIN TEMPERING CIRCUITRY	22JUNE00	JCN

REV.	DESCRIPTION	DATE	BY
D	REVISED SINGLE PHASE MOTOR OVERLOAD CIRCUIT. ADDED TROUBLESHOOTING GUIDE	25SEP00	JCN
E	REVISED TIMING SWITCH WIRING	28FEB01	JCN
F	ADDED NC DRAIN VALVE CIRCUITRY	30MAR01	JCN

Champion
 The Dishwashing Machine Specialists

D-H1/BTE - ELECTRONIC CONTROLS STEAM/ELECTRIC- 1 & 3 PHASE		
B	701648	REV. F

**