

Champion[®]

SERVICE REPLACEMENT PARTS

Undercounter Dishwashers M4 Series



UH130B



UH330B

UH130B M4
High Temperature
with built-in booster
Wash Refresh Final Rinse

UH130 M4
High Temperature
without built-in booster
Wash Refresh Final Rinse

UH230B M4
High Temperature
with built-in booster
Fresh Water Final Rinse

UH230 M4
High Temperature
without built-in booster
Fresh Water Final Rinse

UH330B M4.2
Condensate Removal
High Temperature
with built-in booster
Fresh Water Final Rinse

UL130 M4
Low Temperature
Chemical Sanitization
Wash Refresh Final Rinse

**THE MODELS CONTAINED IN THIS MANUAL COMPLY
WITH ANSI/ASSE 1001 & ANSI/ASSE 1004.**

**WARNING
DO NOT STORE WET DISH RACKS ON TOP OF
MACHINE.**

Storing wet dish racks on top of the machine without
a DRIP TRAY KIT installed will void the warranty.
Order Drip Tray Kit, P/N [0714208](#), (see page 64).



www.championindustries.com

Issue Date: 11.27.23

Manual P/N 115440 rev. N4d

For machines beginning with S/N W140946406 and above

3765 Champion Blvd.,
Winston-Salem, NC 27105
(336) 661-1556 Fax: (336) 661-1660
Toll-free: 1(800) 858-4477

2674 N. Service Road, Jordan Station
Ontario, Canada L0R 1S0
(905) 562-4195 Fax: (905) 562-4618
Toll-free: 1(800) 263-5798

Printed in the USA



The Spirit of Excellence

National Service Department

In Canada:

Toll-free: (800) 263-5798

Tel: (905) 562-4195

Fax: (905) 562-4618

email: service@moyerdiebellimited.com

In the USA:

Toll-free: (800) 858-4477

Tel: (336) 661-1556

Fax: (336) 661-1660

email: service@championindustries.com

ATTENTION:

The model no., serial no., voltage, Hz and phase are needed to identify your machine and to answer questions.

The machine data plate is located on the lower front panel.

Please have this information ready if you call for service assistance.



CAUTION:

Only use a non-chlorinated commercial detergent in the dishwasher.

Two ways to REGISTER YOUR PRODUCT and ACTIVATE YOUR WARRANTY.

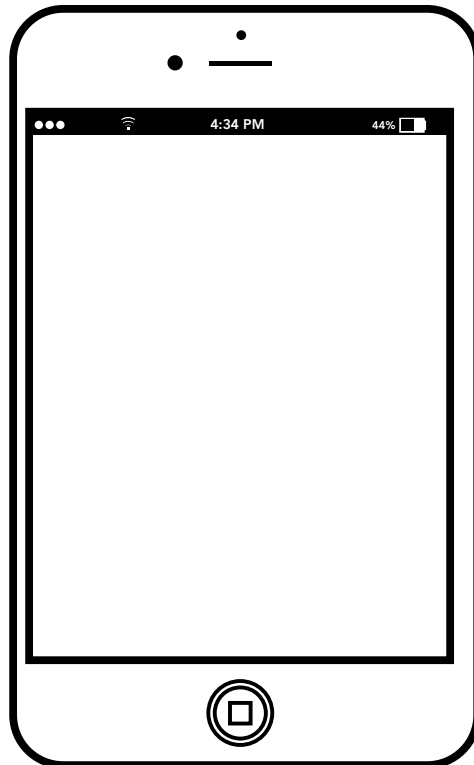

- Use your mobile or computer to go to our website at www.championindustries.com and register your product.
- or
- Use the fax form on the next page.

Champion[®]

The Dishwashing Machine Specialists

PRODUCT REGISTRATION BY FAX

COMPLETE THIS FORM AND FAX TO:

(336) 661-1660 in the USA

1-(800) 204-0109 in Canada

PRODUCT REGISTRATION CARD

Model

Serial #

Date of Installation: ___/___/___

Company Name: _____

Address: _____ (Street) _____ Province _____ Postal Code _____

Telephone #: () _____ --- _____

Contact: _____

Installation Company: _____

Address: _____

Telephone #: _____

Contact: _____

FAILURE TO REGISTER YOUR PRODUCT MAY VOID YOUR WARRANTY

IMPORTANT

IMPORTANT

Revision History

Specifications are subject to change based on continual product improvement.

Revision Date	Revised Pages	Serial Number Effectivity	Revision Description
11.5.14	All	W140946406	Released First Edition
4.27.15	34-38	All	UH130, UH130B use 0706635 squeeze tube and pump
5.13.15	43	All	Changed 6A fuse P/N to 0513698
7.17.15	32-33	All	Added Item 23, Rinse Aid pump motor, P/N 0510872-1
8.31.15	36-37 54-55	All All	Added P/N WS1 to Chemical Pump Revised Control Panel, changed P/N 0512213 to 0512214
10.21.15	24-25	W150954629	Added 5KW Booster Element 111235-1 . Revised Rinse Aid Fittings.
5.17.16	29	W150954629	Added Booster Service Kit, P/N 0714170 to Bstr. Added Insulation P/N 0512790
10.31.16	59	All	Changed Item 9 P/N to 0313404
3.20.17	5	All	Changed Item 15 to P/N 0513325
3.24.17	FC	All	Added ANSI/ASSE compliance note.
4.23.18	53	W160659926	Changed Item 6 to P/N 0513579-1 and Item 7 to P/N 0713583
	59	W160659926	Changed Item 1 to P/N 0313405 and Item 7 to P/N 0313584-1
1.14.19	48-51	W190183363 W190183364	UH130, U130B obsoleted at S/N W190183363 New UH130, UH130B released at S/N W190183364
12.4.19	18-19 44-45	W170568116 All	Added Item 11, P/N 0514324 , Rinse pump manifold Added Item 7a, P/N 0513699 , Upper Wash Hose for UH330B.
9.16.22	20-21, 22-23 29 54-55	All All W191293567	Added P/N 0513569 , Grommet Blower Drive End Changed Item 8, Booster Tank, to P/N 0714284 Updated UL130 Control Panel Added Booster Service Kit, P/N 0714700
	56-57, 58-59 64	All All	Added Drip Tray Kit P/N 0714208 (See pg.64) Added Drip Tray Kit Warning
	29 49.51.53	Prior to S/N W170568116 All	Removed UH330B Booster Service Kit, P/N 0714170 Changed Display Bd. P/N from 0512106-1 to P/N 0712106 .
11.27.23	59	All	Changed Item 9, P/N 0313404 to P/N 0313626.

Limited Warranty

LIMITED WARRANTY

Champion Industries (herein referred to as Champion), 3765 Champion Blvd., Winston-Salem, North Carolina 27105, and P.O. Box 301, 2674 N. Service Road, Jordan Station, Canada, LOR 1S0, warrants machines, and parts, as set out below.

Warranty of Machines: Champion warrants all new machines of its manufacture bearing the name "Champion" and installed within the United States and Canada to be free from defects in material and workmanship for a period of one (1) year after the date of installation or fifteen (15) months after the date of shipment by Champion, whichever occurs first. [See below for special provisions relating to glasswashers.]

Warranty registration must be submitted to Champion within ten (10) days after installation either online on the Champion Industries website (<http://www.championindustries.com/register>) in the USA or <http://www.championindustries.com/canada/register> in Canada or by fax on the form provided at the front of this manual. If warranty registration is not returned to Champion within such period, the warranty will expire after one year from the date of shipment.

Champion will not assume any responsibility for extra costs for installation in any area where there are jurisdictional problems with local trades or unions. If a defect in workmanship or material is found to exist within the warranty period, Champion, at its election, will either repair or replace the defective machine or accept return of the machine for full credit; provided; however, as to glasswashers, Champion's obligation with respect to labor associated with any repairs shall end (a) 120 days after shipment, or (b) 90 days after installation, whichever occurs first. In the event that Champion elects to repair, the labor and work to be performed in connection with the warranty shall be done during regular working hours by a Champion authorized service technician. Defective parts become the property of Champion. Use of replacement parts not authorized by Champion will relieve Champion of all further liability in connection with its warranty. In no event will Champion's warranty obligation exceed Champion's charge for the machine. The following are not covered by Champion's warranty:

- a. Lighting of gas pilots or burners.
- b. Cleaning of gas lines.
- c. Replacement of fuses or resetting of overload breakers.
- d. Adjustment of thermostats.
- e. Adjustment of clutches.
- f. Opening or closing of utility supply valves or switching of electrical supply current.
- g. Cleaning of valves, strainers, screens, nozzles, or spray pipes.
- h. Performance of regular maintenance and cleaning as outlined in operator's guide.
- i. Damages resulting from water conditions, accidents, alterations, improper use, abuse, tampering, improper installation, or failure to follow maintenance and operation procedures.
- j. Wear on Pulper cutter blocks, pulse vanes, and auger brush.

Examples of the defects not covered by warranty include, but are not limited to: (1) Damage to the exterior or interior finish as a result of the above, (2) Use with utility service other than that designated on the rating plate, (3) Improper connection to utility service, (4) Inadequate or excessive water pressure, (5) Corrosion from chemicals dispensed in excess of recommended concentrations, (6) Failure of electrical components due to connection of chemical dispensing equipment installed by others, (7) Leaks or damage resulting from such leaks caused by the installer, including those at machine table connections or by connection of chemical dispensing equipment installed by others, (8) Failure to comply with local building codes, (9) Damage caused by labor dispute.

Warranty of Parts: Champion warrants all new machine parts produced or authorized by Champion to be free from defects in material and workmanship for a period of 90 days from date of invoice. If any defect in material and workmanship is found to exist within the warranty period Champion will replace the defective part without charge.

DISCLAIMER OF WARRANTIES AND LIMITATIONS OF LIABILITY. CHAMPION'S WARRANTY IS ONLY TO THE EXTENT REFLECTED ABOVE. CHAMPION MAKES NO OTHER WARRANTIES, EXPRESS OR IMPLIED, INCLUDING, BUT NOT LIMITED, TO ANY WARRANTY OF MERCHANTABILITY, OR FITNESS OF PURPOSE. CHAMPION SHALL NOT BE LIABLE FOR INCIDENTAL OR CONSEQUENTIAL DAMAGES. THE REMEDIES SET OUT ABOVE ARE THE EXCLUSIVE REMEDIES FOR ANY DEFECTS FOUND TO EXIST IN CHAMPION DISHWASHING MACHINES AND CHAMPION PARTS, AND ALL OTHER REMEDIES ARE EXCLUDED, INCLUDING ANY LIABILITY FOR INCIDENTALS OR CONSEQUENTIAL DAMAGES.

Champion does not authorize any other person, including persons who deal in Champion dishwashing machines to change this warranty or create any other obligation in connection with Champion Dishwashing Machines.

Service Replacement Parts

<i>Illustrations</i>	<i>Page</i>
Wash Pump/Motor Assembly - All Models	2
Base Assembly - All Models.....	4
Fill Piping Assembly - UH130, UH130B, UL130, UH330B	8
Fill Solenoid Valve - UH130, UH130B, UL130, UH330B	10
Fill Piping Assembly - UH230, UH230B.....	12
Fill Rinse Piping Assembly - UH230, UH230B.....	14
Final Rinse Piping - UH330B Prior to S/N W170568116.....	16
Final Rinse Piping - UH330B Beginning with S/N W170568116 and above.....	18
Heat Recovery Assembly - UH330B Prior to S/N W170568116.....	20
Heat Recovery Assembly - UH330B Beginning with S/N W170568116 and above.....	22
Booster Heater and Pressure Switches - UH330B Prior to S/N W170568116.....	24
Booster Heater - UH330B Beginning with S/N W170568116 and above.....	26
Booster Hoses and Level Sensor - UH330B Beginning with S/N W170568116 and above.....	28
Fill Chute Assembly - UH130, UH130B, UL130	30
Chemical Dispensing Pumps - UH130, UH130B, UH230, UH230B	32
Chemical Dispensing Pumps - UH330B.....	34
Chemical Dispensing Pumps - UL130.....	36
Booster Assembly - UH130B, UH230B	38
Power Input Block and Cord Assemblies - All Models.....	40
Timer Control Board Assembly - All Models	42
Wash and Rinse Spray Arms and Drain Valve - UH230, UH230B, UH330B	44
Wash/Rinse Spray Arm and Drain Valve - UH130, UH130B, UL130	46
Control Panel - UH130, UH130B.....	48
Control Panel - UH230, UH230B.....	50
Control Panel - UH330B.....	52
Control Panel - UL130	54
Panels - UH130, UH130B, UH230, UH230B, UL130.....	56
Panels - UH330B.....	58
Door Assembly - All Models.....	60
Dish Racks, Line Strainer, PRV	62
Drip Tray Kit - P/N 0714208	64

Wash Pump/Motor Assembly - All Models

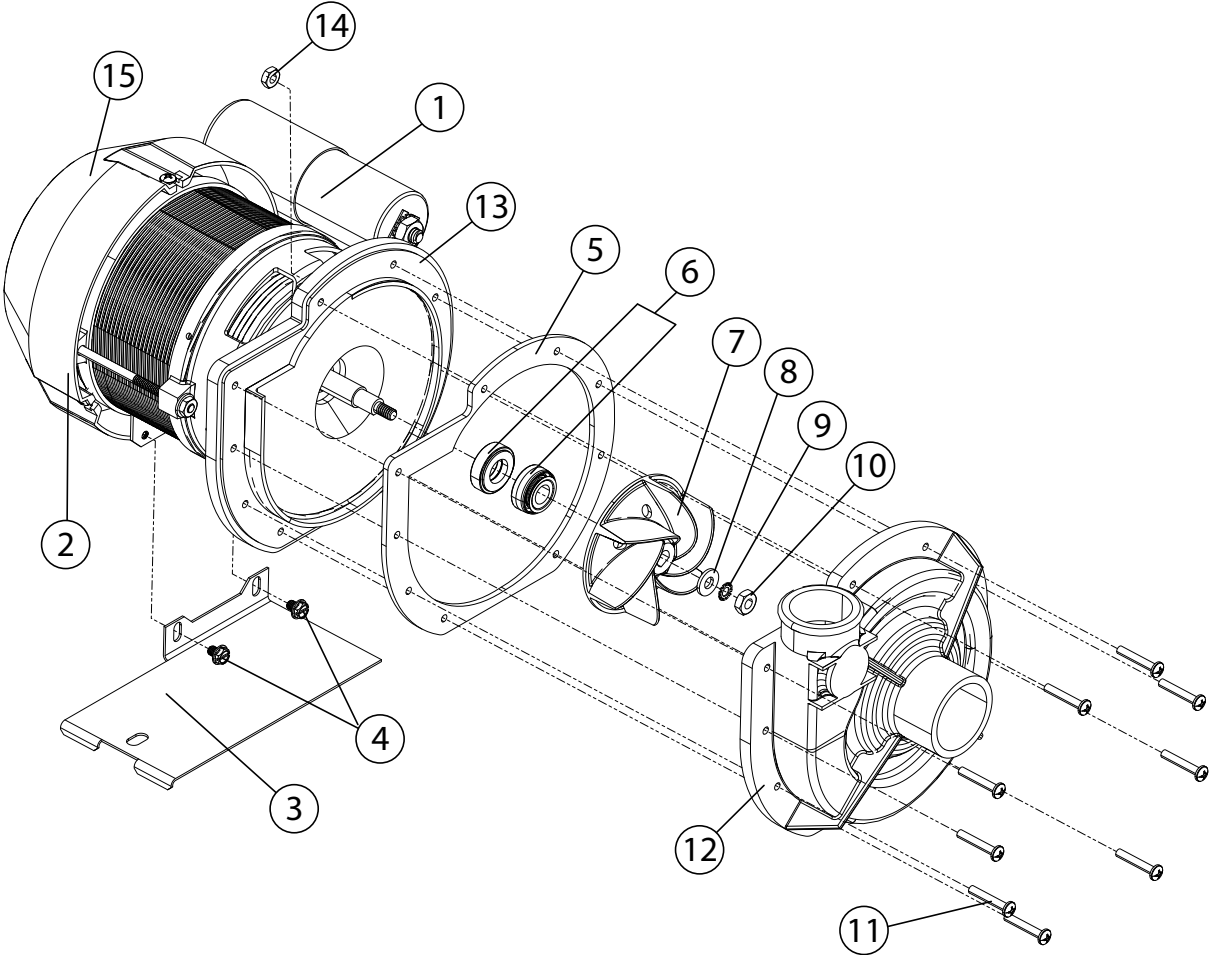

All Models - Wash Pump/Motor Assembly

Item No.	Part No.	Description	Qty.
1	0512347	CAPACITOR 40 μ F	1
2	0512101	PUMP/MOTOR ASSEMBLY COMPLETE 115VAC/60/1	1
3	0313394	BRACKET, WASH PUMP	1
4	0512185	BOLT, HEX FLANGE 1/4-20 X 3/8" SST	2
5	110285	GASKET	1
6	114139	SEAL	1
7	0512345	IMPELLER	1
8	0501478	WASHER, PLAIN, 17/64"	1
9	106482	WASHER, LOCK, 1/4"	1
10	114144	NUT, M6	1
11	0512340	SCREW, M4, PHIL, PAN HD.	9
12	0512341	VOLUTE, PUMP	1
13	114137	BACKPLATE, PUMP	1
14	107337	NUT, M4	9
15	0513131	COVER, REAR MOTOR FAN	1

NOTE: The pump motor is not sold separately.

Base Assembly - All Models

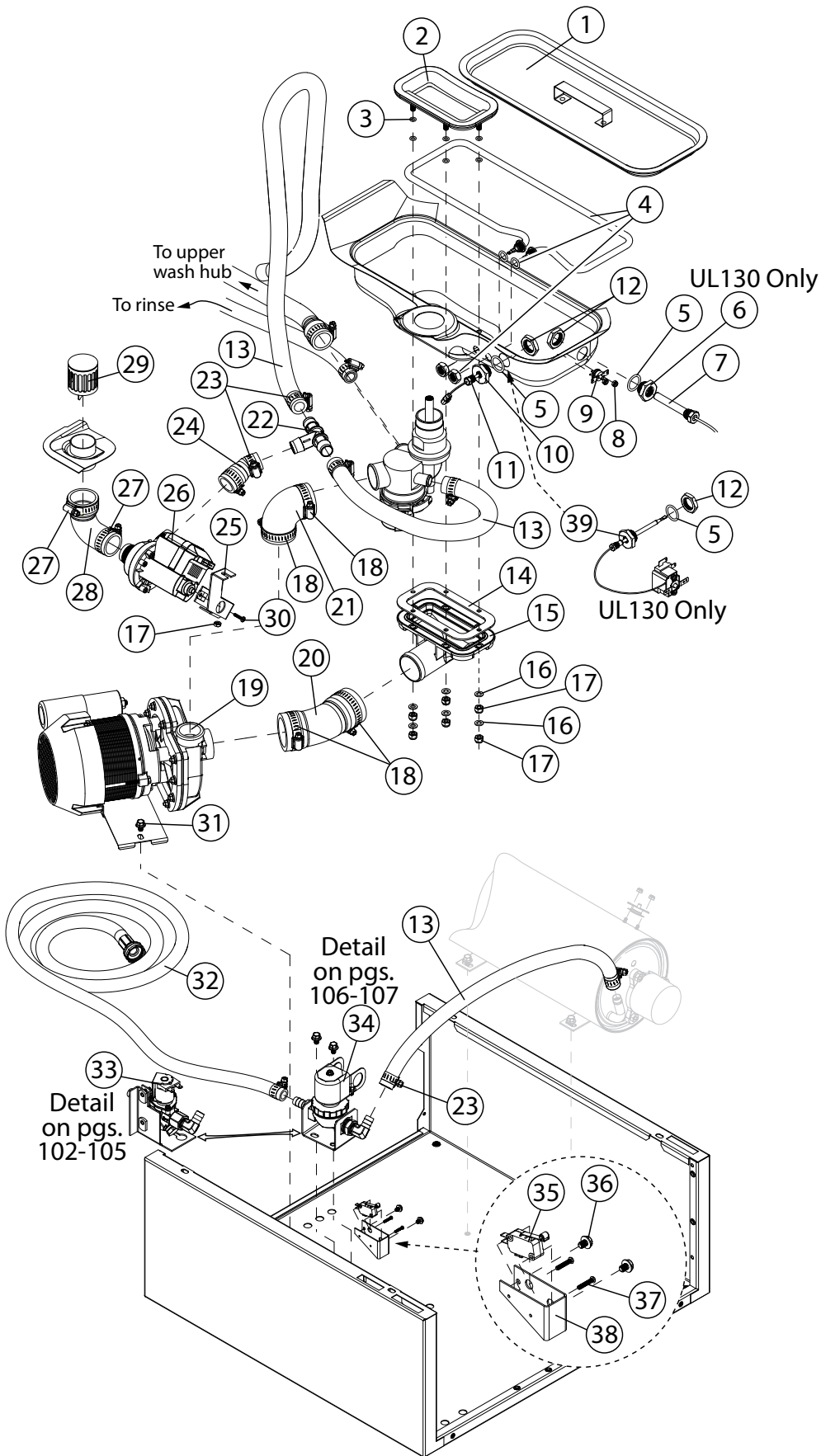

All Models - Base Assembly

Item No.	Part No.	Description	Qty.
1	0512136	SCREEN, SCRAP ASSY.	1
2	0513324	FLANGE, PUMP SUCTION	1
3	0513677	O-RING	A/R
4	0512169	HEATER, 120VAC 750W) <i>(UL130)</i>	1
—	0512426	HEATER, 240VAC 2000W <i>(All except UL130)</i>	1
5	0512099	O-RING	1
6	0508872	ADAPTOR, THERMOMETER <i>(UL130 Only)</i>	1
7	0512107	THERMOMETER, WASH TANK <i>(UL130 Only)</i>	1
8	108954	NUT, GRIP 6-32 WITH NYLON INSERT SST	2
9	113604	THERMOSTAT, HI-LIMIT BI-METAL SNAP, 212°F	1
10	0512299	ADAPTOR, THERMISTOR	1
11	112612	THERMISTOR, 10 KΩ, 2 WIRE ASSY, WASH TANK <i>(All except UL130)</i>	1
12	201029-1	NUT, LOCK 1/2 INCH NI PLATED	A/R
13	0509302	HOSE, 5/8" ID X 1" OD	A/R
14	0513329	GASKET, PUMP SUCTION	1
15	0513325	ELBOW, PUMP SUCTION	1
16	0501476	WASHER	6
17	107967	NUT, 1/4-20 W/NYLON INSERT SST	6
18	0502571	CLAMP, HOSE 1-1/16" - 2"	2
19	0512101	PUMP/MOTOR COMPLETE 115/60/1	1
20	0513328	HOSE, PUMP SUCTION	1
21	0512119	HOSE, PUMP DISCHARGE	1
22	0512134	TEE, 3/4", POLY.	1
23	0508808	CLAMP, SS GEAR	2
24	0313171	HOSE, MOULDED 2-1/2"	1
25	0312145	BRACKET, DRAIN PUMP <i>(UH230, UH230B, UH330B)</i>	1

All Models - Base Assembly

Item No.	Part No.	Description	Qty.
26	0512227	PUMP, DRAIN 115VAC (<i>UH230, UH230B, UH330B</i>)	1
27	0512322	CLAMP, HOSE	2
28	0513339	HOSE, OVERFLOW (<i>UH230, UH230B, UH330B</i>)	1
29	0712236	TUBE, OVERFLOW GUARD (<i>UH230, UH230B</i>)	1
—	0712236-1	TUBE, OVERFLOW GUARD (<i>UH330B ONLY</i>)	1
30	109835	SCREW #8 X 1/2" SELF-TAPPING SST	1
31	0512185	BOLT, HEX FLANGE 1/4-20 X 3/8" SST	1
32	0509526	HOSE, 1/2" X 7 FT. FEM. GARD. ADAPT.	1
33	0504952	VALVE, FILL 5.0 GPM (<i>UH130, UH130B, UL130</i>)	1
—	0513557	VALVE, FILL 1.0 GPM (<i>UH330B Only</i>)	1
34	109886	VALVE, SOLENOID, 1/2" NPT (<i>UH230, UH230B</i>)	1
35	0501379	SWITCH, 15A	1
36	0512792	SCREW, 10-32 X 1/4" RD. HD. PHILL. SST	2
37	0508752	SCREW, 4-40 X 5/8" RH. HD. PHILL. SST	2
38	0313432	BRACKET, DOOR SWITCH	1
39	0507323	THERMOSTAT, WASH (<i>UL130 Only</i>)	1

***This Page
Intentionally
Left Blank***

Fill Piping Assembly - UH130, UH130B, UL130, UH330B

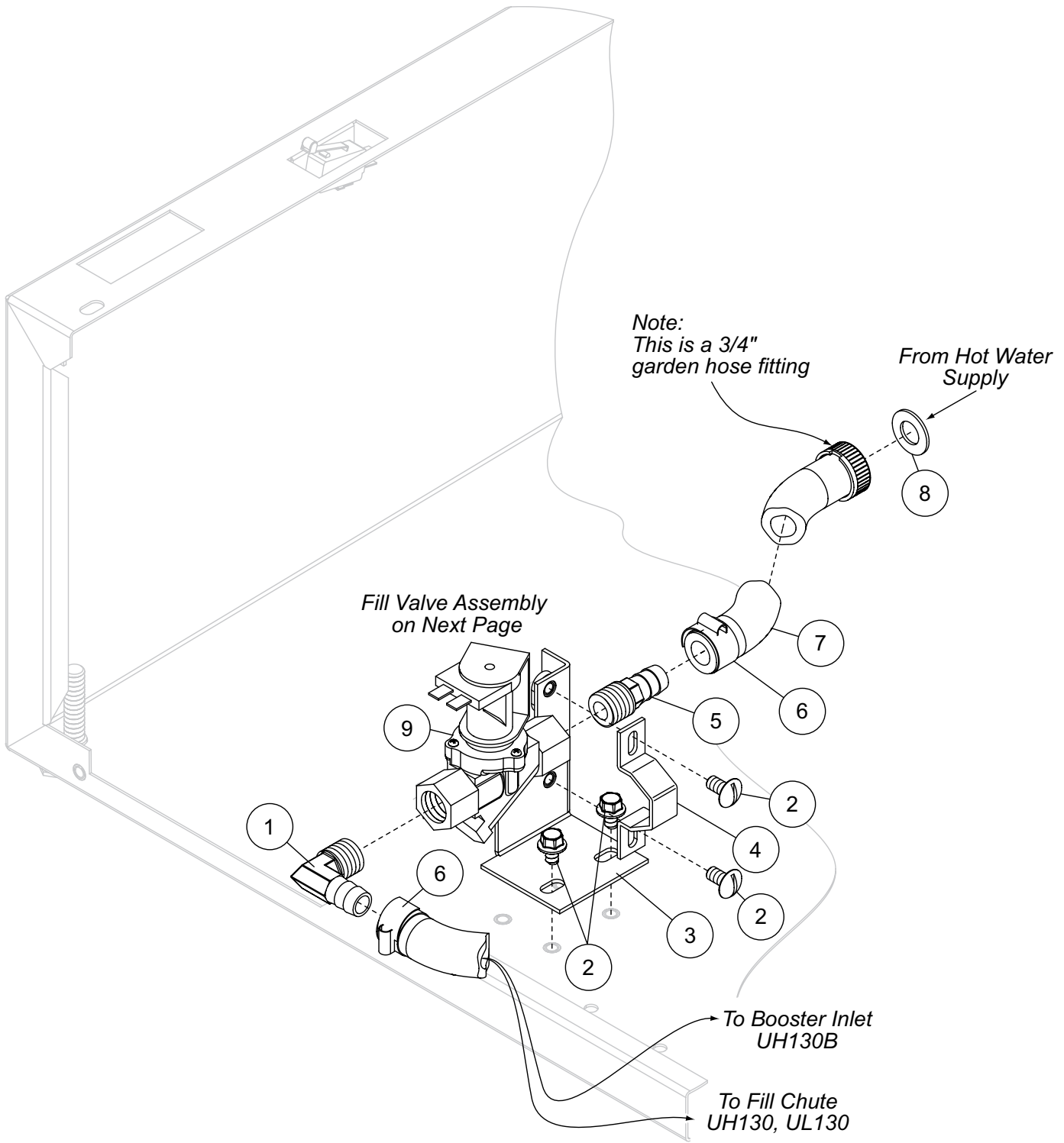

UH130, UH130B, UL130, UH330B - Fill Piping Assembly

Item No.	Part No.	Description	Qty.
1	0502653	ELBOW, 90° 3/8" MPT X 1/2" HOSE	1
2	0512185	BOLT, HEX FLANGE 1/4-20 X 3/8" SST	4
3	0300065	SUPPORT, VALVE	1
4	0300203	CLAMP, VALVE	1
5	0502618	HOSE BARB, 1/2" X 3/8" MPT	1
6	0512985	CLAMP, HOSE	1
7	0509526	HOSE, 1/2" X 7 FT. FEM. GARD. ADAPT.	1
8	0505320	WASHER, 1" OD GARDEN HOSE	1
9	0504952	VALVE, FILL, 5.0 GPM (EXCEPT UH330B)	1
—	0513557	VALVE, FILL 1.0 GPM (UH330B ONLY)	1

Fill Solenoid Valve - UH130, UH130B, UH330B, UL130

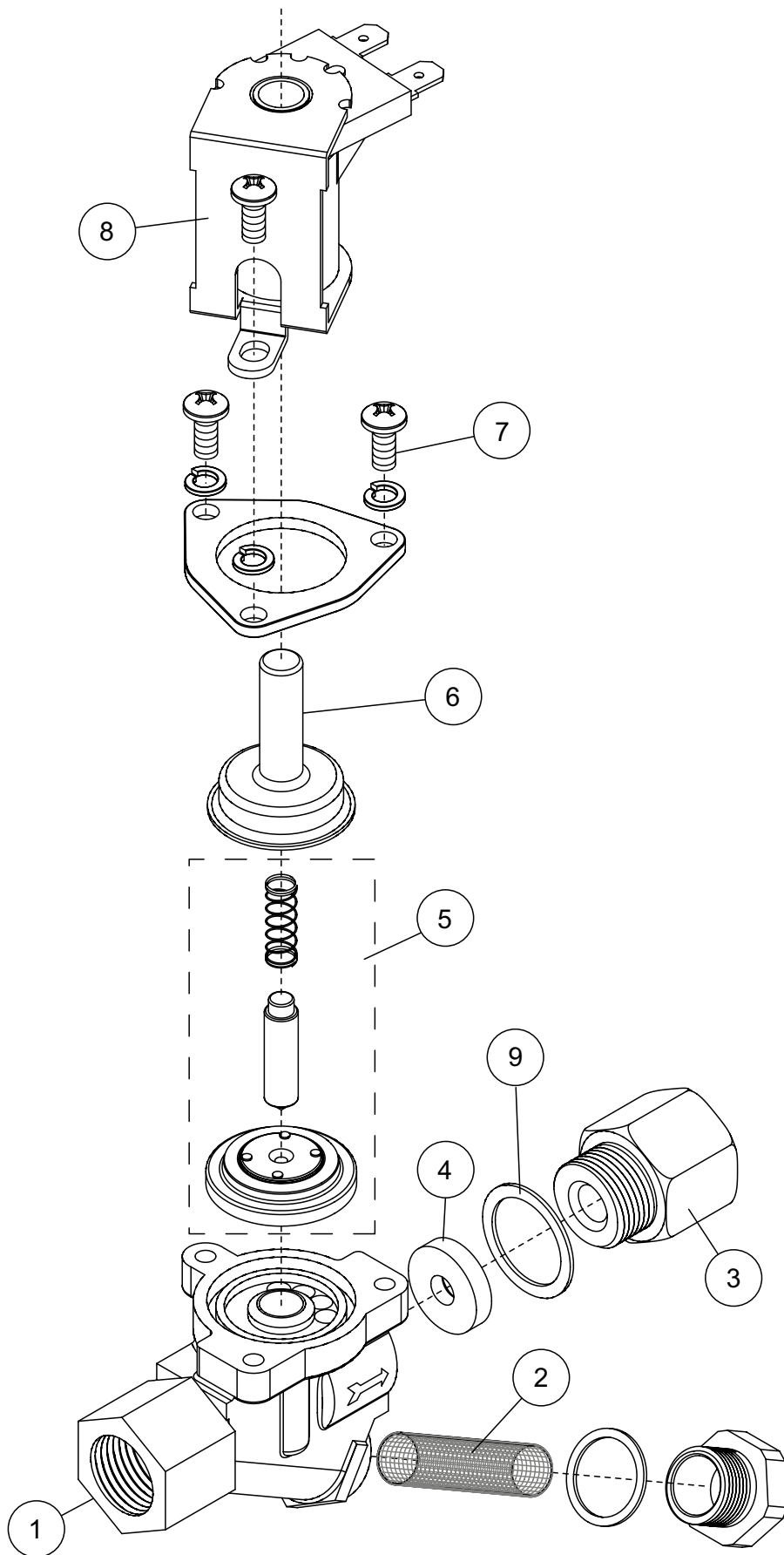

UH130, UH130B, UH330B, UL130 - Fill Solenoid Valve

Item No.	Part No.	Description	Qty.
1	0504952	VALVE, FILL 5.0 GPM (EXCEPT UH330B)	1
–	0513557	VALVE, FILL 1.0 GPM (UH330B ONLY)	1
2	0502803	SCREEN, VALVE STRAINER	1
3	0502804	GASKET, CAP	1
4	0504958	WASHER, FLOW 5.0 GPM (EXCEPT UH330B)	1
–	0513674	WASHER, FLOW 1.0 GPM (UH330B ONLY)	1
5	0502811	KIT, REBUILD	1
6	0505229	GUIDE	1
7	0501406	SCREW, SLOT SS RH 8-32 X 1/2"	3
8	0505235	COIL, 115V 60HZ 10W	1
9	0502807	GASKET, OUTLET (COPPER)	1

Fill Piping Assembly - UH230, UH230B

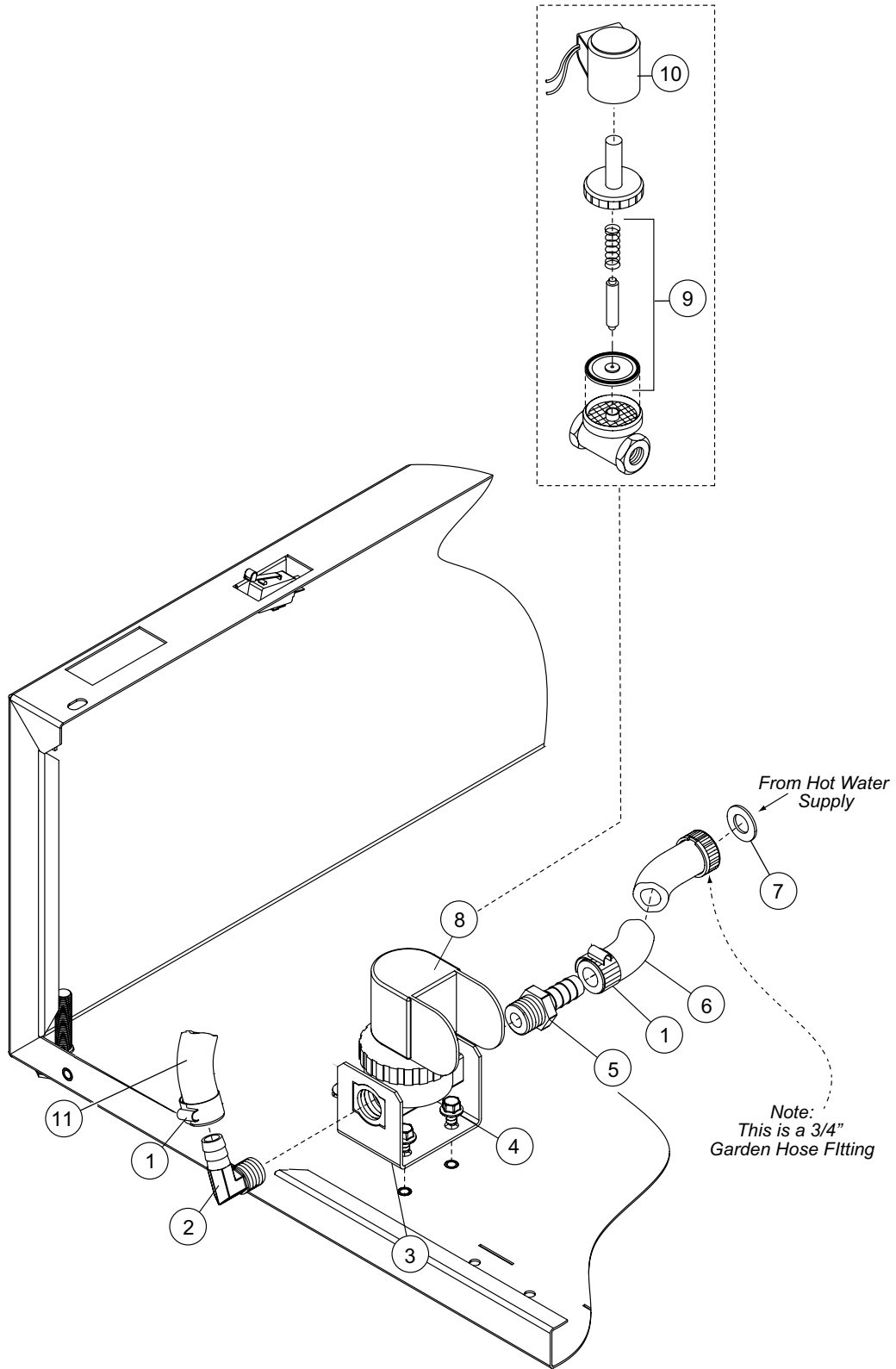

UH230, UH230B - Fill Piping Assembly

Item No.	Part No.	Description	Qty.
1	0512985	CLAMP, HOSE	2
2	0508782	ELBOW, 90° 1/2" MPT X 1/2" HOSE	1
3	0312146	BRACKET, 1/2" SOLENOID VALVE (UH230, UH230B)	1
4	0512185	BOLT, HEX FLANGE 1/4-20 X 3/8" SS	2
5	0502618	BARB, HOSE 1/2" X 3/8" MPT	1
6	0509526	HOSE, 1/2" X 7 FT. FEM. GARD. ADAPT.	1
7	0505320	WASHER, 1" OD GARDEN HOSE	1
8	109886	VALVE, SOLENOID, 1/2" NPT 120VAC	1
9	109902	KIT, REPAIR, 1/2" SOLENOID VALVE	1
10	108516	KIT, REPAIR, COIL, 120VAC	1
11	107417	HOSE, RUBBER 1/2" ID X .84" OD	A/R

Upper Final Rinse Piping - UH230, UH230B

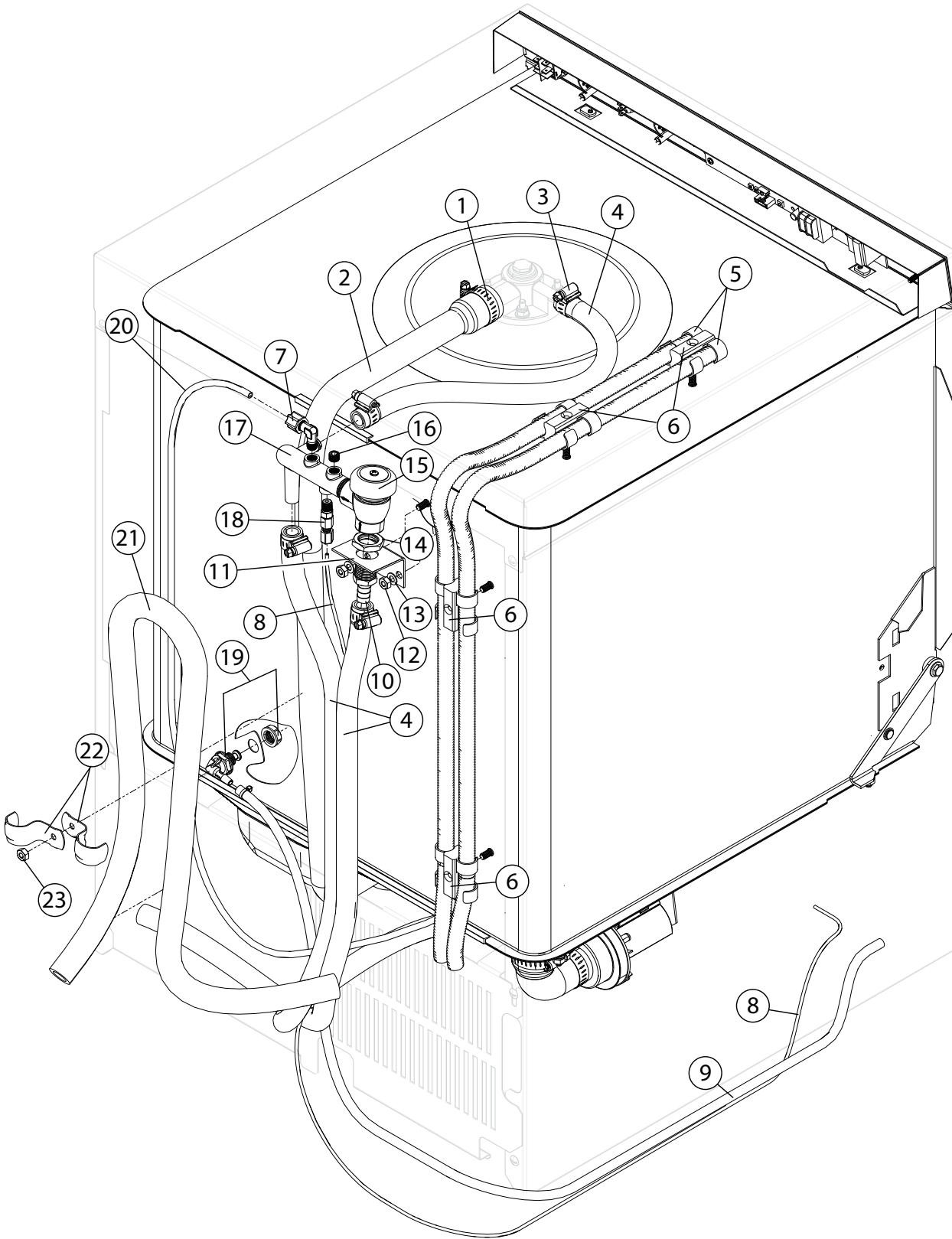

UH230, UH230B - Upper Final Rinse Piping

Item No.	Part No.	Description	Qty.
1	0502571	CLAMP, HOSE	1
2	0512120	HOSE, UPPER WASH	1
3	0512985	CLAMP, HOSE	A/R
4	107417	HOSE, RUBBER 1/2" ID X .84" OD	A/R
5	0512757	CONDUIT, 1/2"	A/R
—	0512758	CONDUIT, 3/8"	A/R
6	0512369	CLAMP, CONDUIT	4
7	112728	ELBOW, 1/8" MPT X 1/4" COMP PP	1
8	112883-1	TUBING, 1/8" OD X 1/16" ID (RINSE-AID)	A/R
9	0502667	TUBING, 1/4" ID X 3/8" OD (DETERGENT)	A/R
10	0502651	COUPLER 1/2" MPT X 1/2" HOSE	1
11	0312190	BRACKET, VACUUM BREAKER	1
12	100003	NUT, HEX SST 1/4-20	2
13	106482	WASHER, SPLIT LOCK 1/4" SST	2
14	201029-1	NUT, LOCK 1/2" NICKEL PLATED	1
15	100500	VACUUM BREAKER, 1/2" NPT, BRONZE	1
—	900836	REPAIR KIT, VACUUM BREAKER 1/2"	1
16	0508817	PLUG, 1/8" HEX COUNTERSUNK	A/R
17	0513110	MANIFOLD, RINSE	1
18	112763	FITTING, INJECTOR RINSE-AID (UH230, UH230B ONLY)	1
19	0713656	KIT, DETERGENT FITTING	1
—	110750	GASKET	1
—	0513672	NUT, NP 1/4" NPS PP BLACK	1
20	107928	TUBING, 1/4" NATURAL	AR
21	0509302	HOSE, 5/8" ID X 1" OD	A/R
22	107239	CLAMP, EMT	2
23	107967	NUT, 1/4-20 W/NYLON INSERT SST	1

Final Rinse Piping - UH330B Prior to S/N W170568116

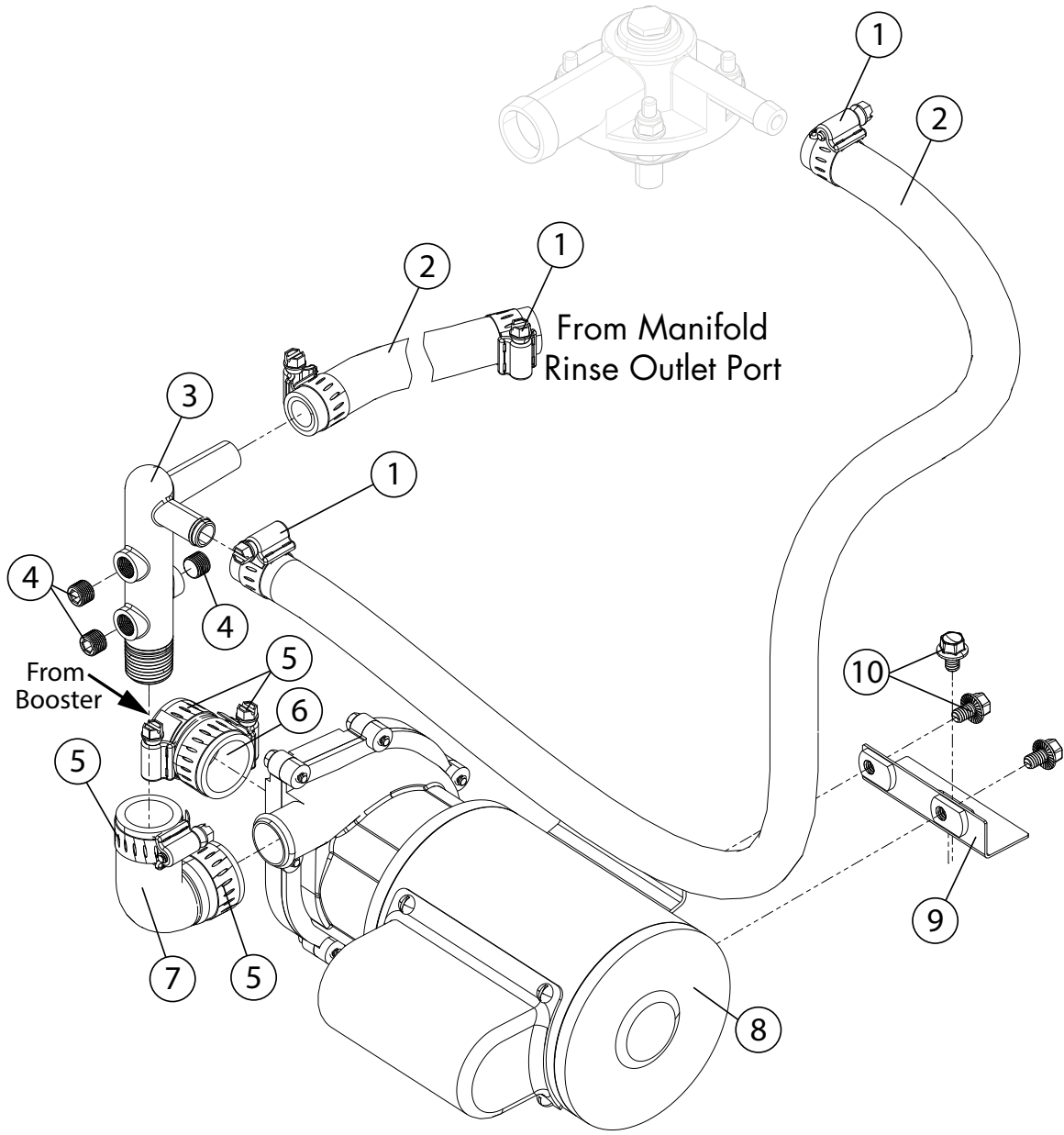

Final Rinse Piping - UH330B Prior to S/N W170568116

Item No.	Part No.	Description	Qty.
1	0512985	CLAMP, HOSE	A/R
2	107417	HOSE, RUBBER 1/2" ID X .84" OD	A/R
3	0513110	MANIFOLD, RINSE	1
4	0508817	PLUG, 1/8" HEX COUNTERSUNK	3
5	0502563	CLAMP	2
6	0513679	HOSE, 1" ID X 1-3/8" BRAIDED	1
7	0513613	HOSE, MOLDED, RINSE DISCHARGE	1
8	115231	PUMP/MOTOR, RINSE	1
9	0313610	BRACKET, RINSE PUMP	1
10	0512185	BOLT, HEX FLANGE 1/4-20 X 3/8" SST	2

Final Rinse Piping - UH330B beginning with S/N W170568116 and above

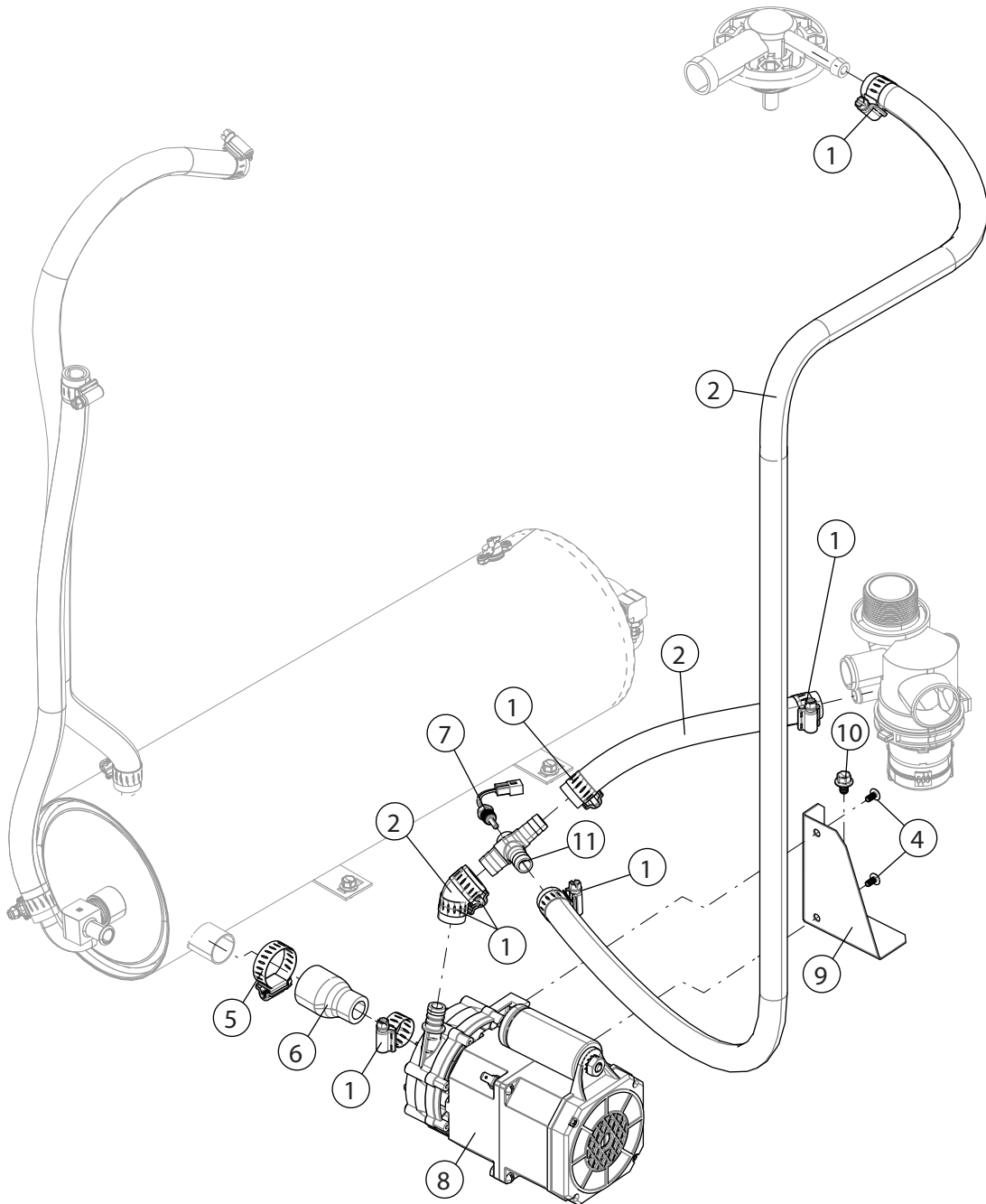

Final Rinse Piping - UH330B beginning with S/N W170568116 and above

Item No.	Part No.	Description	Qty.
1	0512985	CLAMP, HOSE	6
2	107417	HOSE, RUBBER 1/2" ID X .84" OD	A/R
3	0514324	MANIFOLD, RINSE PUMP	1
4	104624	SCREW, 8-32 X 3/8" TRUSS HEAD	2
5	0502563	CLAMP	1
6	0514323	HOSE, MOLDED RINSE SUCTION	1
7	112612	THERMISTOR, 10K Ω , 2-WIRE ASSY.	1
8	0514317	PUMP, RINSE 115VAC, HR M4.2	1
9	0314319	BRACKET, PUMP MOUNT	1
10	0512185	BOLT, HEX FLANGE 1/4-20 X 3/8" SS	1
11	0514324	MANIFOLD, RINSE PUMP M4.2	1

Heat Recovery Assembly - UH330B Prior to S/N W170568116

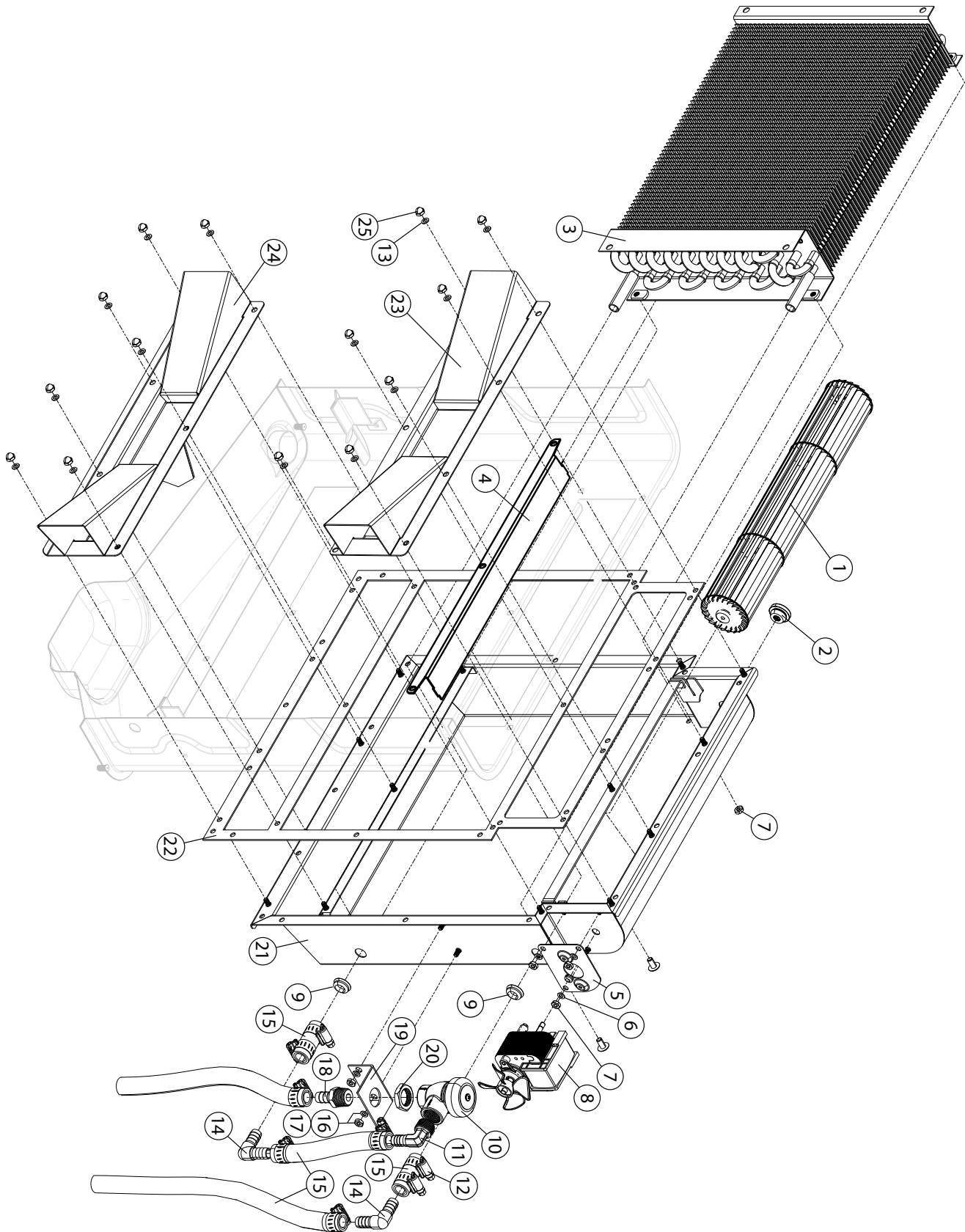

Heat Recovery Assembly - UH330B Prior to S/N W170568116

Item No.	Part No.	Description	Qty.
1	0513572	BLOWER	1
2	0513574	BEARING (COMES WITH RUBBER HSG.)	2
3	0513571	COIL, HEAT RECOVERY	1
4	0313599	DEFLECTOR, FAN AIR	1
5	0313594	MOUNT, FAN MOTOR	1
6	0502808	WASHER	2
7	0503580	NUT, 10-32 SST	A/R
8	0513573	MOTOR, BLOWER 115VAC	1
9	0513732	SEAL, V-RING 1/2"	2
10	100500	BREAKER, VACUUM	1
-	900836	REPAIR KIT, VACUUM BREAKER 1/2"	A/R
11	0508782	ELBOW, 1/2" X 1/2" HOSE BARB	1
12	0512985	CLAMP, HOSE	4
13	0507709	WASHER	A/R
14	0513648	ELBOW, 1/2" HOSE	2
15	107417	HOSE, RUBBER 1/2" ID X .84" OD	A/R
16	100003	NUT, HEX 1/4-20 SST	2
17	106482	WASHER, SPLIT LOCK 1/4" SST	2
18	0502651	COUPLER, 1/2" MPT X 1/2" HOSE	1
19	0312190	BRACKET, VACUUM BREAKER	1
20	201029-1	NUT, LOCK 1/2" NICKEL PLATED	1
21	0713563	HOUSING, COIL	1
22	0513582	GASKET, HOUSING	1
23	0713564	DEFLECTOR, UPPER AIR	1
24	0713566	DEFLECTOR, LOWER AIR	1
25	106481	NUT, CAP 10-32 SST	A/R
26	0513569	GROMMET, BLOWER DRIVER END, 4.5MM	1

Heat Recovery Assembly - UH330B beginning with S/N W170568116 above

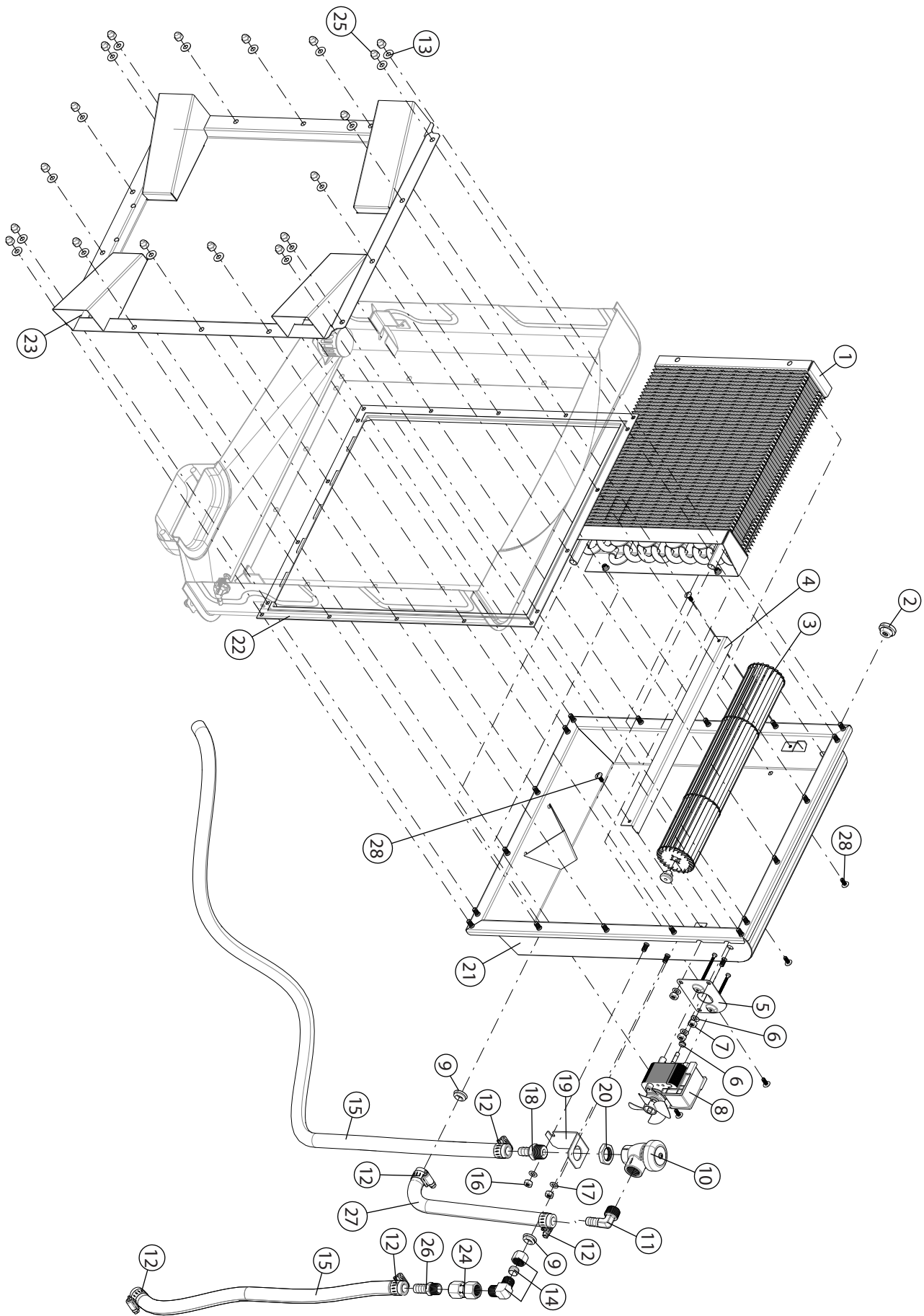

Heat Recovery Assembly - UH330B beginning with S/N W170568116 above

Item No.	Part No.	Description	Qty.
1	0514293	COIL, HEAT RECOVERY M4.2	1
2	0513574	BEARING (COMES WITH RUBBER HSG.)	2
3	0513572	BLOWER	1
4	0314311	DEFLECTOR, FAN AIR M4.2	1
5	0313594	MOUNT, FAN MOTOR	1
6	0502808	WASHER	2
7	0503580	NUT, 10-32 SST	A/R
8	0513573	MOTOR, BLOWER 115VAC	1
9	0513732	SEAL, V-RING 1/2"	2
10	100500	BREAKER, VACUUM	1
-	900836	REPAIR KIT, VACUUM BREAKER 1/2"	A/R
11	0508782	ELBOW, 1/2" X 1/2" HOSE BARB	1
12	0512985	CLAMP, HOSE	4
13	0501476	WASHER	A/R
14	0514316	ELBOW, 1/2" COMP. X 3/8" MNPT BRASS	1
15	107417	HOSE, RUBBER 1/2" ID X .84" OD	A/R
16	100003	NUT, HEX 1/4-20 SST	2
17	106482	WASHER, SPLIT LOCK 1/4" SST	2
18	0502651	COUPLER, 1/2" MPT X 1/2" HOSE	1
19	0314312	BRACKET, VACUUM BREAKER M4.2	1
20	201029-1	NUT, LOCK 1/2" NICKEL PLATED	1
21	0714299	HOUSING, COIL M4.2	1
22	0514313	GASKET, HOUSING M4.2	1
23	0714300	DEFLECTOR, AIR M4.2	1
24	0507324	VALVE, CHECK 3/8"	1
25	106014	NUT, ACORN 1/4-20 SST	A/R
26	0502618	BARB, HOSE 1/2" X 3/8" MPT	1
27	0514322	HOSE, HEAT EXCHANGE COIL SUPPLY M4.2	1
28	100007	SCREW, 10-32 X 3/8" TRUSS HEAD SST	A/R
29	0513569	GROMMETT, BLOWER DRIVE END, 4.5MM	1

Booster Heater and Pressure Switches - UH330B Prior to S/N W170568116

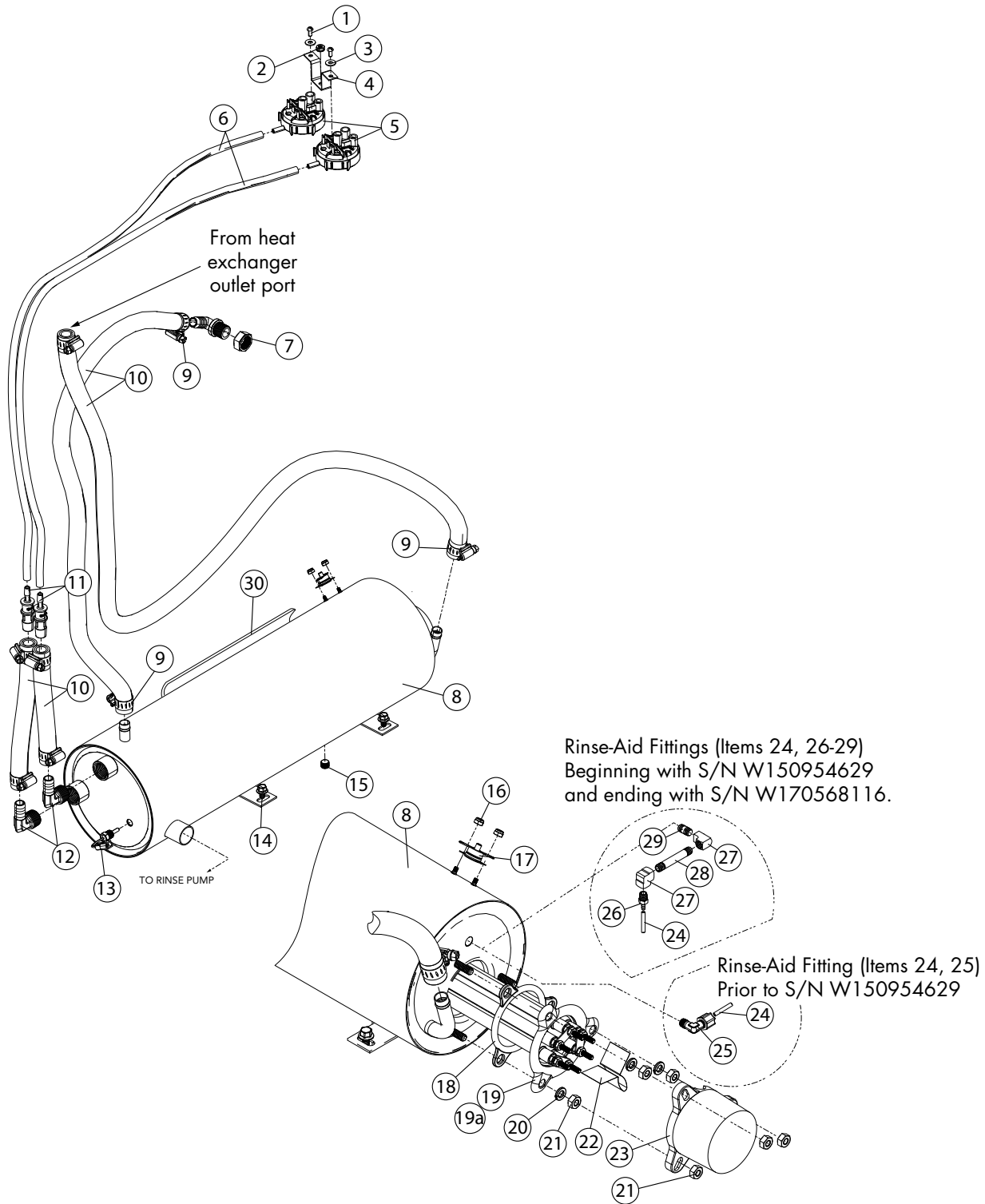

Booster Heater and Pressure Switches - UH330B Prior to S/N W170568116

Item No.	Part No.	Description	Qty.
1	109835	SCREW, #8 X 1/2" PAN HD. PHIL. SST	4
2	0503580	NUT 10-32 SST	4
3	0507709	WASHER, FLAT #10 SST	4
4	0313587	BRACKET, PRESSURE SWITCH	2
5	H31171	SWITCH, PRESSURE	2
6	H160121	HOSE, EPDM	A/R
7	0513731	ELBOW, 1/4 NPT X 1/2" HOSE (C/W NUT)	1
8	0714284	TANK, BOOSTER	1
9	0512985	HOSE, CLAMP	A/R
10	107417	HOSE, RUBBER 1/2" ID X .84" OD	A/R
11	0513650	ADAPTER, 1/2" X 1/4" HOSE	2
12	0508782	ELBOW, 1/2" NPT X 1/2" HOSE	2
13	112612	THERMISTOR, 10 K Ω , 2-WIRE	1
14	0512185	BOLT, HEX FLANGE 1/4-20 X 3/8" SST	2
15	0508817	PLUG, 1/8"	1
16	108954	NUT, GRIP 6-32 W/NYLON INSERT	2
17	110562	THERMOSTAT, HIGH LIMIT 240°F	1
18	109985	SEAL, ELEMENT BOOSTER	1
19	0513654	BOOSTER, ELEMENT 4.3 KW	1
20	106482	WASHER, LOCK 1/4" SPLIT SST	3
21	100003	NUT, PLAIN 1/4-20 SST	6
22	111885	INSULATOR	1
23	107908	COVER, ELEMENT	1
24	112883-1	TUBING, 1/8" OD X 1/16" ID (RINSE-AID)	A/R
25	112728*	FITTING	1
26	0514158	ADAPTER, 1/8" HOSE X 1/8" MNPT BRASS	1
27	0514156	ELBOW, 1/8" X 1/8" NPT BRASS	2
28	0514155	NIPPLE, 1/8" X 2" BRASS	1
29	100939	NIPPLE, CLOSE 1/8" NPT BRASS	1
30	0512790	INSULATION, BOOSTER TANK	1
—	0714700	BOOSTER ASSEMBLY COMPLETE	A/R
—	0513538	HARNESS, BOOSTER CONTROL WIRING (<i>Not Shown</i>)	1

Booster Heater - UH330B beginning with S/N W170568116 and above

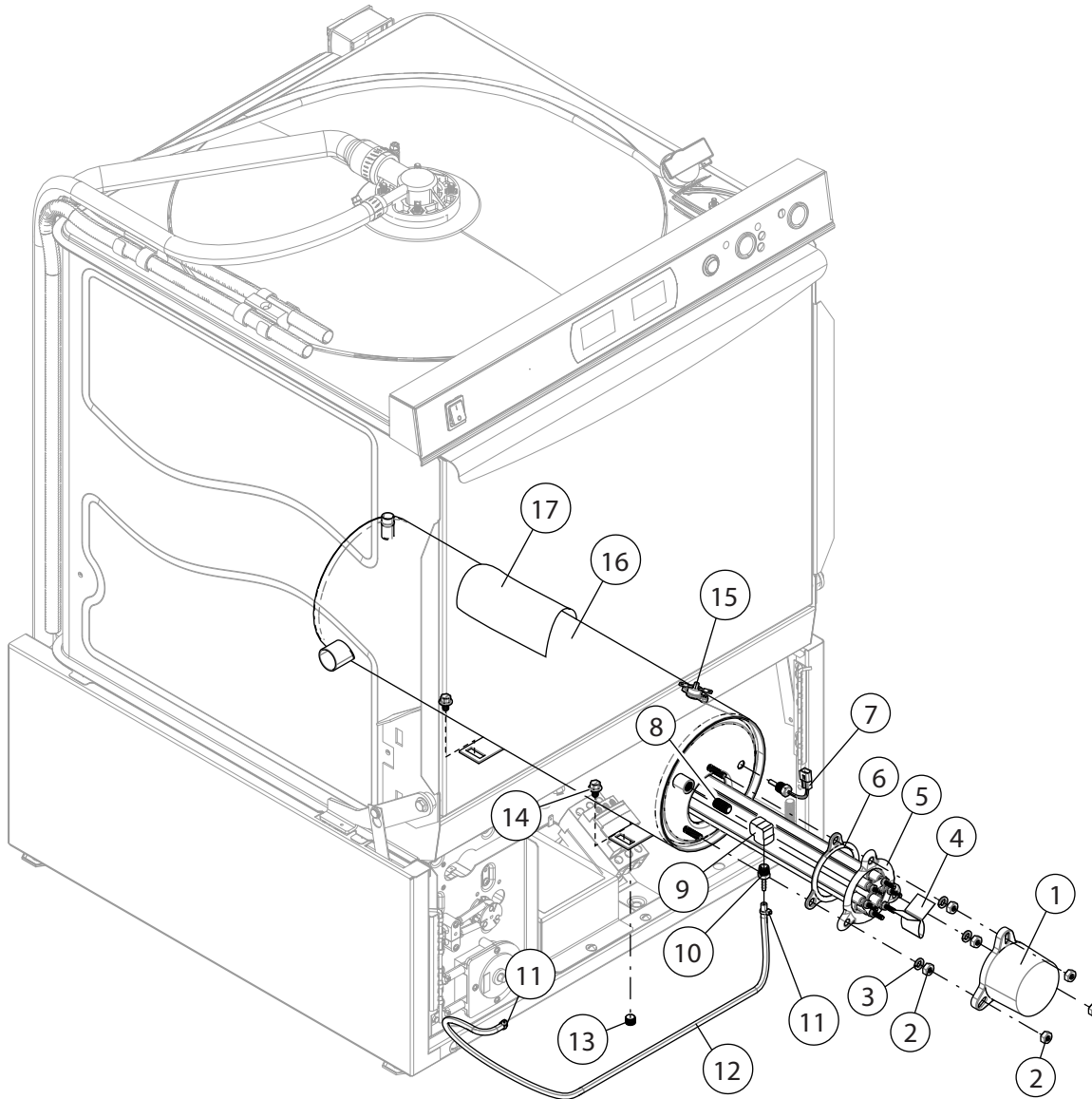

Booster Heater - UH330B beginning with S/N W170568116 and above

Item No.	Part No.	Description	Qty.
1	107908	COVER, ELEMENT	1
2	100003	NUT, PLAIN 1/4-20 SST	6
3	106482	WASHER, LOCK 1/4" SPLIT SST	3
4	111885	PAPER, FISH	1
5	0514296	BOOSTER, ELEMENT 4.3 KW	1
6	109985	SEAL, ELEMENT BOOSTER	1
7	0513310	THERMISTOR, PROBE	1
8	100939	NIPPLE, CLOSE 1/8" NPT BRASS	1
9	0514156	ELBOW, 1/4" X 1/8" NPT BRASS	1
10	0514158	ADAPTER, 1/8" HOSE X 1/8" MNPT BRASS	1
11	0501519	TIE, CABLE 4"	2
12	0502666	HOSE, 1/8" ID X 1/4" OD PVC	A/R
13	0508817	PLUG, 1/8" HEX COUNTERSUNK SST	1
14	0512185	BOLT, HEX FLANGE 1/4-20 X 3/8" SST	2
15	110562	THERMOSTAT, HIGH LIMIT 240°F	1
16	0714284	TANK, BOOSTER	1
17	0512790	INSULATION, BOOSTER TANK	1
18	0514198	NIPPLE, 1/8" HEX BRASS - NOT SHOWN	1
19	0514318	ELBOW, 1/2" X 1/2MNPT BRASS - NOT SHOWN	1
—	0714700	KIT, BOOSTER SERVICE (Includes items 4, 5, 6, 7, 9, 10, 13, 15, 16, 17, 18, 19)	A/R

Booster Hoses and Level Sensor - UH330B beginning with S/N W170568116 and above

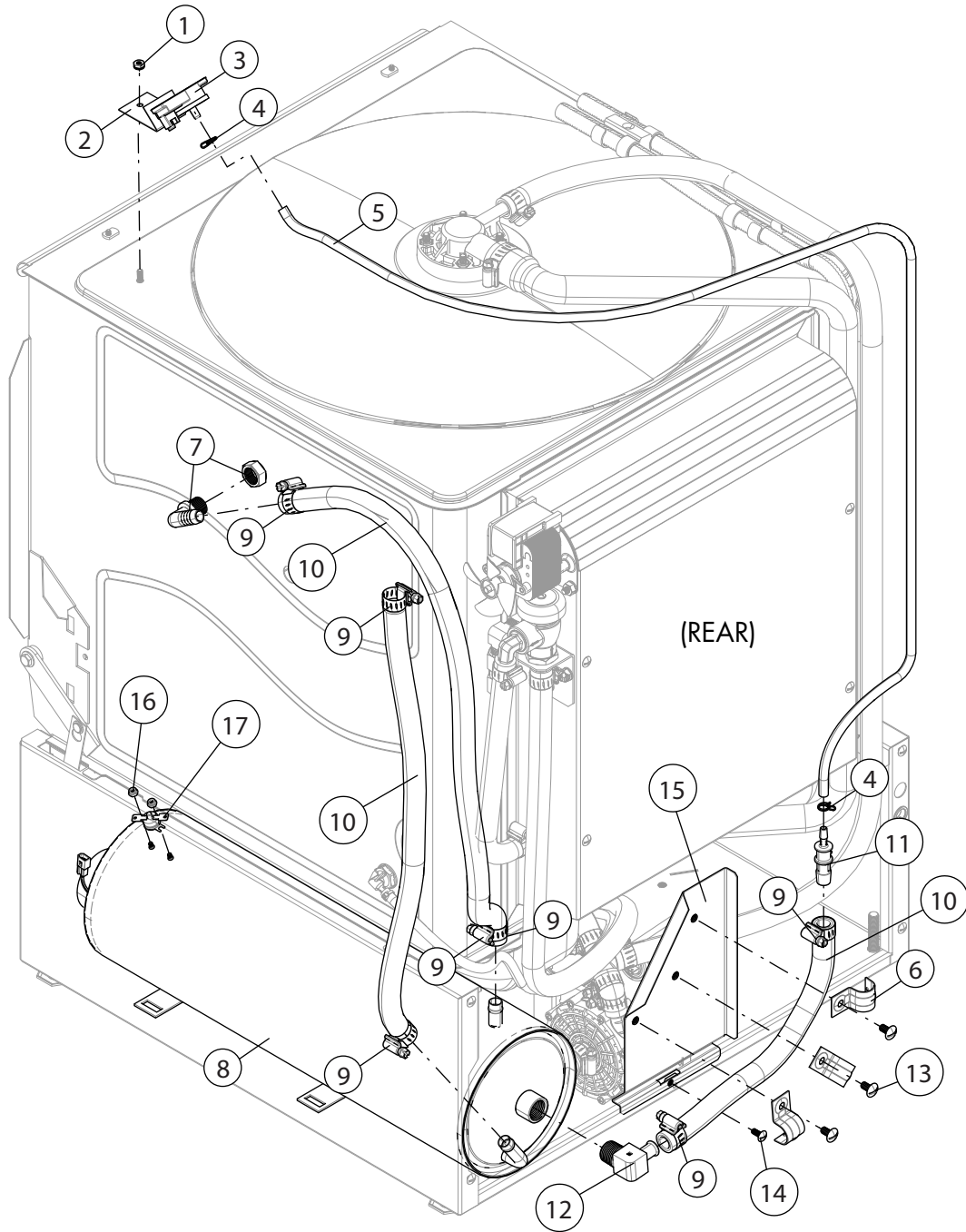

Booster Hoses and Level Sensor - UH330B beginning with S/N W170568116 and above

Item No.	Part No.	Description	Qty.
1	0503580	NUT, KEPS 10-32 SST	1
2	0313865	BRACKET, SENSOR	1
3	0513831	SENSOR, LEVEL	1
4	0513696	CLAMP, DOUBLE SPRING 10.7 MM PLATED	2
5	H160121	HOSE, EPDM	A/R
6	0513736	CLAMP, EMT 1/2"	3
7	0513731	ELBOW, 1/4 NPT X 1/2" HOSE (C/W NUT)	1
8	0713565	TANK, BOOSTER	1
9	0512985	CLAMP, HOSE	6
10	107417	HOSE, RUBBER 1/2" ID X .84" OD	A/R
11	0513650	ADAPTER, 1/2" X 1/4" HOSE	2
12	0514318	ELBOW, 1/2" HOSE X 1/2" MNPT BRASS	1
13	100073	SCREW, 1/4-20 X 1/2" TRUSS HEAD SST	3
14	100007	SCREW, 10-32 X 1/2" TRUSS HEAD SST	1
15	0314320	BRACKET, PRESSURE TUBE M4.2	1
16	108954	NUT, GRIP 6-32 W/NYLON INSERT	2
17	110562	THERMOSTAT, HIGH LIMIT 240°F	1

Fill Chute Assembly - UH130, UH130B, UL130

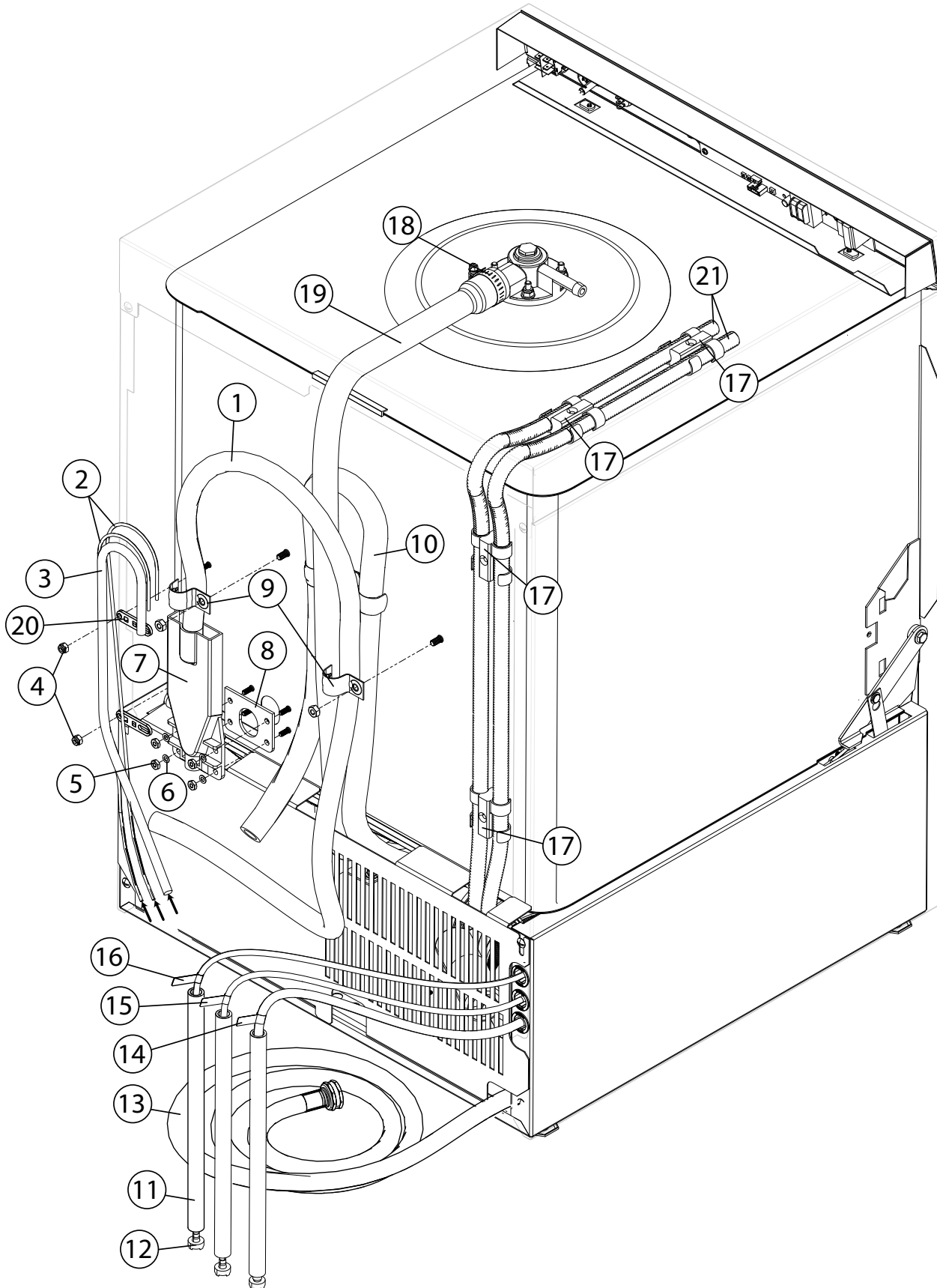

UH130, UH130B, UL130 - Fill Chute Assembly

Item No.	Part No.	Description	Qty.
1	107417	HOSE, RUBBER 1/2" ID X .84" OD	A/R
2	0502666	HOSE, 1/8" ID X 1/4" OD PVC	A/R
3	0502667	HOSE, 1/4" ID X 3/8" OD PVC	A/R
4	100194	NUT, GRIP 10-32 W/NYLON INSERT	2
5	0503722	NUT, HEX 10-32 SST	4
6	0507709	WASHER, FLAT #10 SST	4
7	0508867	CHUTE, INLET	1
8	0509048	GASKET, INLET CHUTE	1
9	0308822	CLAMP, EMT 1/2"	1
10	0509302	HOSE, 5/8" ID X 1" OD PVC BRAIDED	A/R
11	0306363	TUBE, STIFFENER	A/R
12	0501869	STRAINER	A/R
13	0509526	HOSE, FILL 1/2" X 7 FT. FEM. GARD. ADAPT.	1
14	0503695	LABEL, DETERGENT HOSE	1
15	0505483	LABEL, RINSE-AID HOSE	1
16	0503694	LABEL, SANITIZER HOSE (UL130 ONLY)	1
17	0512369	CLAMP, CONDUIT	4
18	0502571	CLAMP, HOSE GEAR	A/R
19	0512120	HOSE, WASH	1
20	106090	TIE PLATE	2
—	0501518	TIE, NYLON 5-1/2"	2
21	0512757	CONDUIT, 1/2"	A/R
—	0512758	CONDUIT, 3/8"	A/R

Chemical Dispensing Pumps - UH130, UH130B, UH230, UH230B

UH130, UH130B RINSE ONLY

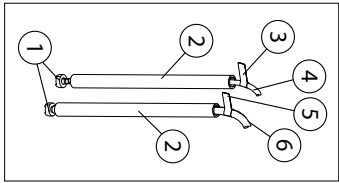
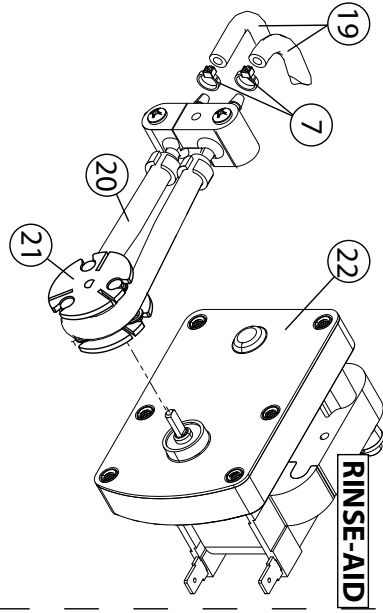

IMPORTANT:
Check Items #9 and #10 every 6 months and replace if stretched or worn.

UH230, UH230B RINSE ONLY

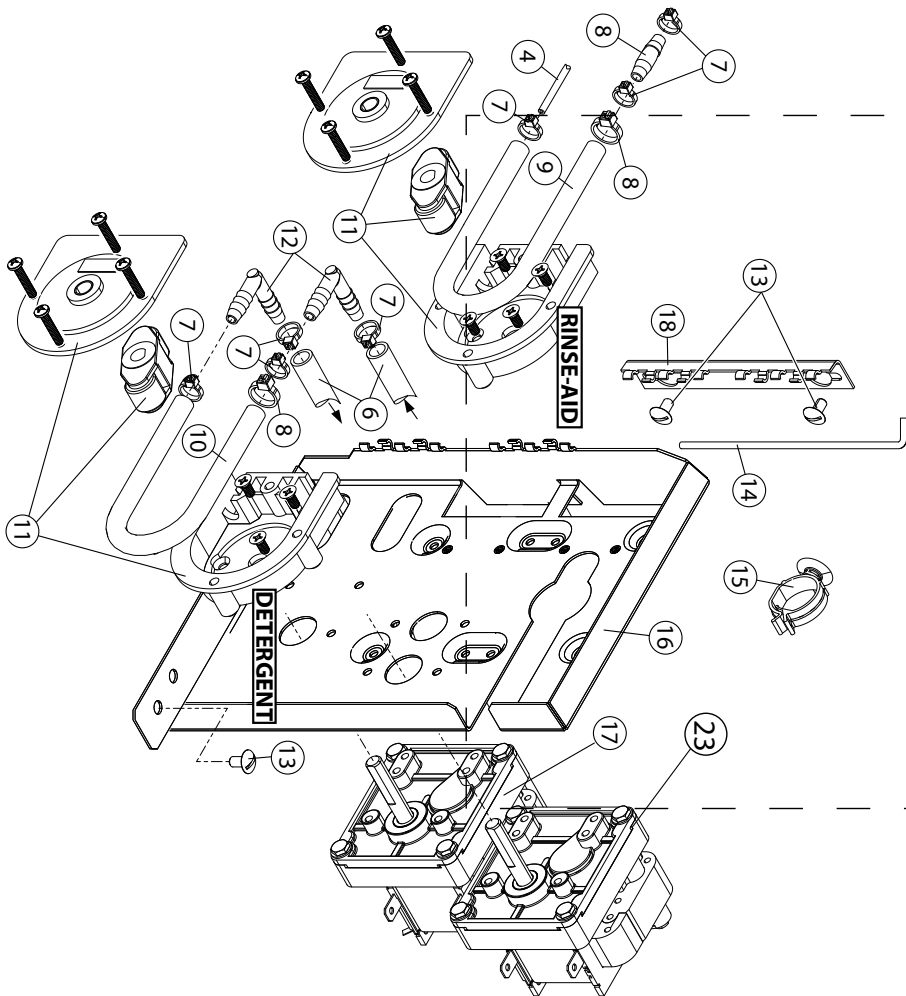

UH130, UH130B, UH230, UH230B - Chemical Dispensing Pumps

Item No.	Part No.	Description	Qty.
1	0501869	STRAINER	2
2	0306363	TUBE, 3/8" ID X 12" LG. STIFFENER	1
3	0505483	LABEL, RINSE-AID HOSE	1
4	112883-1	TUBING, 1/8" OD X 1/16" ID	A/R
5	0503695	LABEL, DETERGENT HOSE	A/R
6	0502667	HOSE, 1/4" ID X 3/8" OD PVC	A/R
7	0501519	TIE, NYLON 4"	9
8	0512369	CLAMP, HOSE	2
9	112759	TUBE, PUMP 1/8" ID X 9" LG.	1
10	114202	TUBE, PUMP 3/16" ID X 3/8" OD X 9" LG.	1
11	114203	PUMP HD KIT, PERISTALIC	2
12	0502644	ELBOW, 1/4" HOSE BARB	2
13	100007	SCREW, 10-32 X 3/8" TRUSS SST	3
14	0313644	PIN, HINGE	1
15	0513645	HOLDER, CABLE	4
16	0313393	BRACKET, CHEMICAL PUMP	1
17	0510870-1	GEARMOTOR, 115/60/1, DETERGENT PUMP	1
18	0313431	BRACKET, HINGED PANELS	1
19	0502666	HOSE, 1/8" ID X 1/4" OD PVC	A/R
20	0706635	TUBE, ELEMENT 45 CC	1
21	0707142	ROTOR	1
22	0503756	MOTOR, INJECTOR PUMP	1
23	0510872-1	GEARMOTOR, 115/60/1, RINSE-AID PUMP	1

Chemical Dispensing Pumps - UH330B

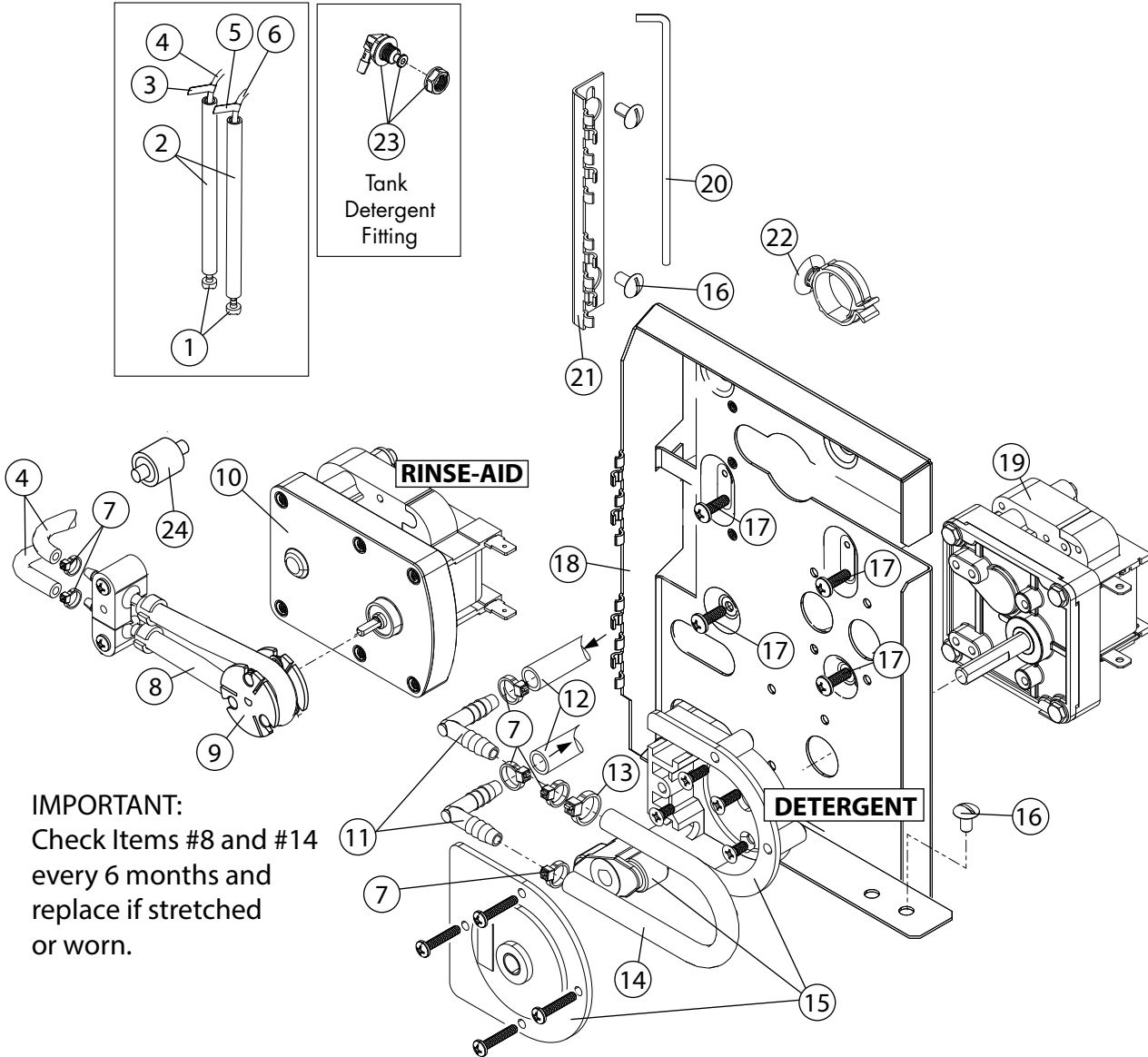

IMPORTANT:
 Check Items #8 and #14
 every 6 months and
 replace if stretched
 or worn.

UH330B - Chemical Dispensing Pumps

Item No.	Part No.	Description	Qty.
1	0501869	STRAINER	2
2	0306363	TUBE, 3/8" ID X 12" LG. STIFFENER	1
3	0505483	LABEL, RINSE-AID HOSE	1
4	0502666	HOSE, 1/8" ID X 1/4" OD PVC	A/R
5	0503695	LABEL, DETERGENT HOSE	A/R
6	0502667	HOSE, 1/4" ID X 3/8" OD PVC	A/R
7	0501519	TIE, NYLON 4"	7
8	0706635	TUBE, ELEMENT ASSEMBLY 45CC	1
9	0707142	ROTOR	1
10	0503756	MOTOR, INJECTOR PUMP	1
11	0502644	ELBOW, 1/4" HOSE BARB	2
12	0502667	HOSE, 1/4" ID X 3/8" OD PVC	A/R
13	0512369	CLAMP, HOSE	1
14	114202	TUBE, 3/16" ID X 3/8" OD X 9" LG.	1
15	114203	PUMP HD KIT, PERISTALIC	1
16	100007	SCREW, 10-32 X 3/8" TRUSS SST	3
17	0504822	SCREW, 8-32 X 1/2" PAN HD. SST	4
18	0313393	BRACKET, CHEMICAL PUMP	1
19	0510870-1	GEARMOTOR, 115/60/1, DETERGENT PUMP	1
20	0313644	PIN, HINGE	1
21	0313431	BRACKET, HINGED PANELS	1
22	0513645	HOLDER, CABLE	4
23	0713656	KIT, DETERGENT FITTING	1
—	110750	GASKET	1
—	0513672	NUT, NP 1/4" NPS PP BLACK	1
24	0513745	VALVE, CHECK	1

Chemical Dispensing Pumps - UL130

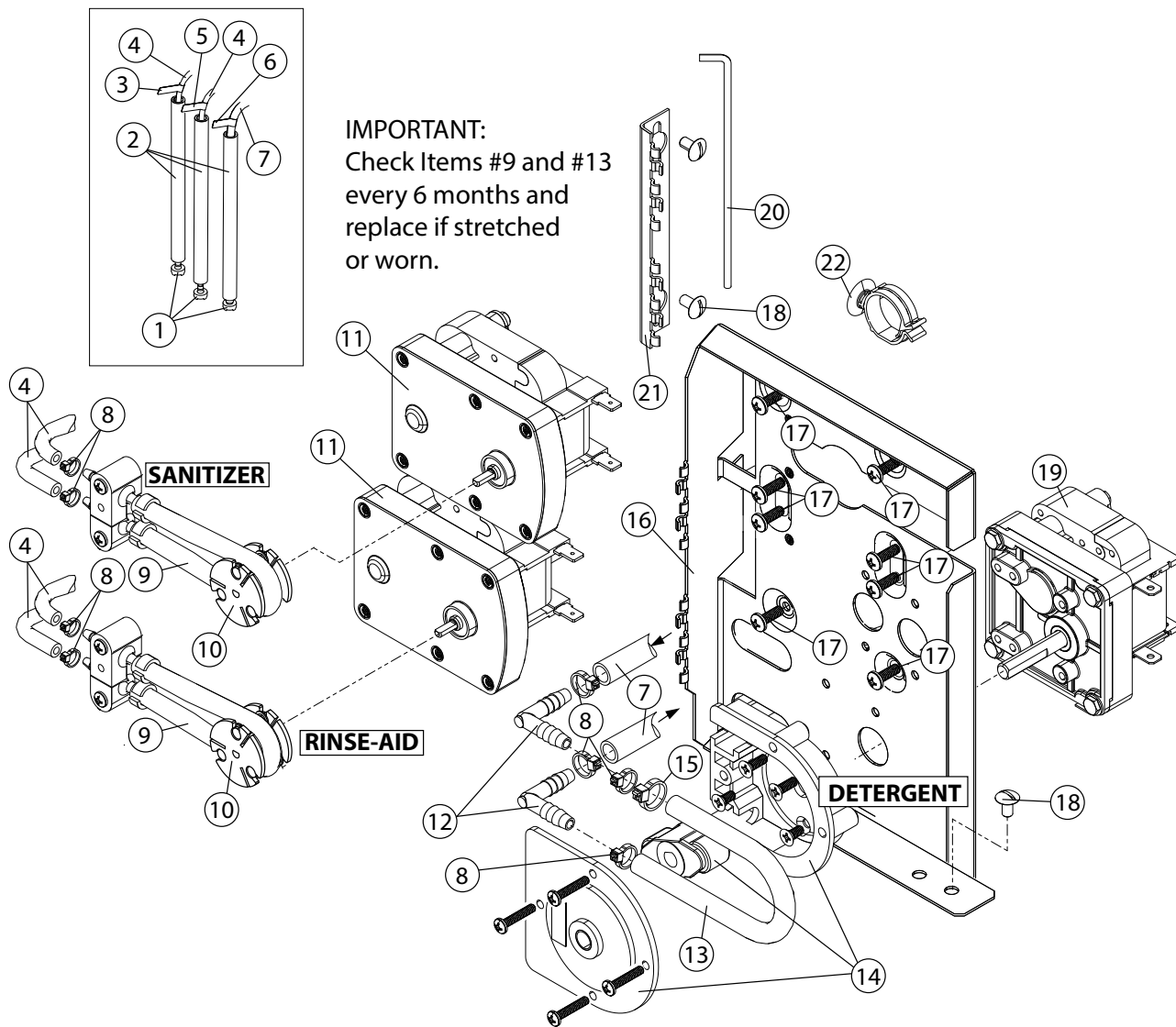

UL130 - Chemical Dispensing Pumps

Item No.	Part No.	Description	Qty.
1	0501869	STRAINER	2
2	0306363	TUBE, 3/8" ID X 12" LG. STIFFENER	1
3	0505483	LABEL, RINSE-AID HOSE	1
4	0502666	HOSE, 1/8" ID X 1/4" OD PVC	A/R
5	0503694	LABEL, SANITIZER HOSE	A/R
6	0503695	LABEL, DETERGENT HOSE	A/R
7	0502667	HOSE, 1/4" ID X 3/8" OD PVC	A/R
8	0501519	TIE, NYLON 4"	7
9	0706635	TUBE, ELEMENT ASSEMBLY 45CC	1
10	0707142	ROTOR	1
11	0503756	MOTOR, INJECTOR PUMP	1
12	0502644	ELBOW, 1/4" HOSE BARB	2
13	114202	TUBE, 3/16" ID X 3/8" OD X 9" LG.	1
14	114203	PUMP HD KIT, PERISTALIC	1
15	0512369	CLAMP, HOSE	1
16	0313393	BRACKET, CHEMICAL PUMP	1
17	0504822	SCREW, 8-32 X 1/2" PAN HD. SST	4
18	100007	SCREW, 10-32 X 3/8" TRUSS SST	3
19	0510870-1	GEARMOTOR, 115/60/1	1
20	0313644	PIN, HINGE	1
21	0313431	BRACKET, HINGED PANELS	1
22	0513645	HOLDER, CABLE	4
—	WS1	FLOAT TUBE SENSOR, CHEMICAL ALARM <i>(Not Shown)</i>	1

Booster Assembly - UH130B, UH230B

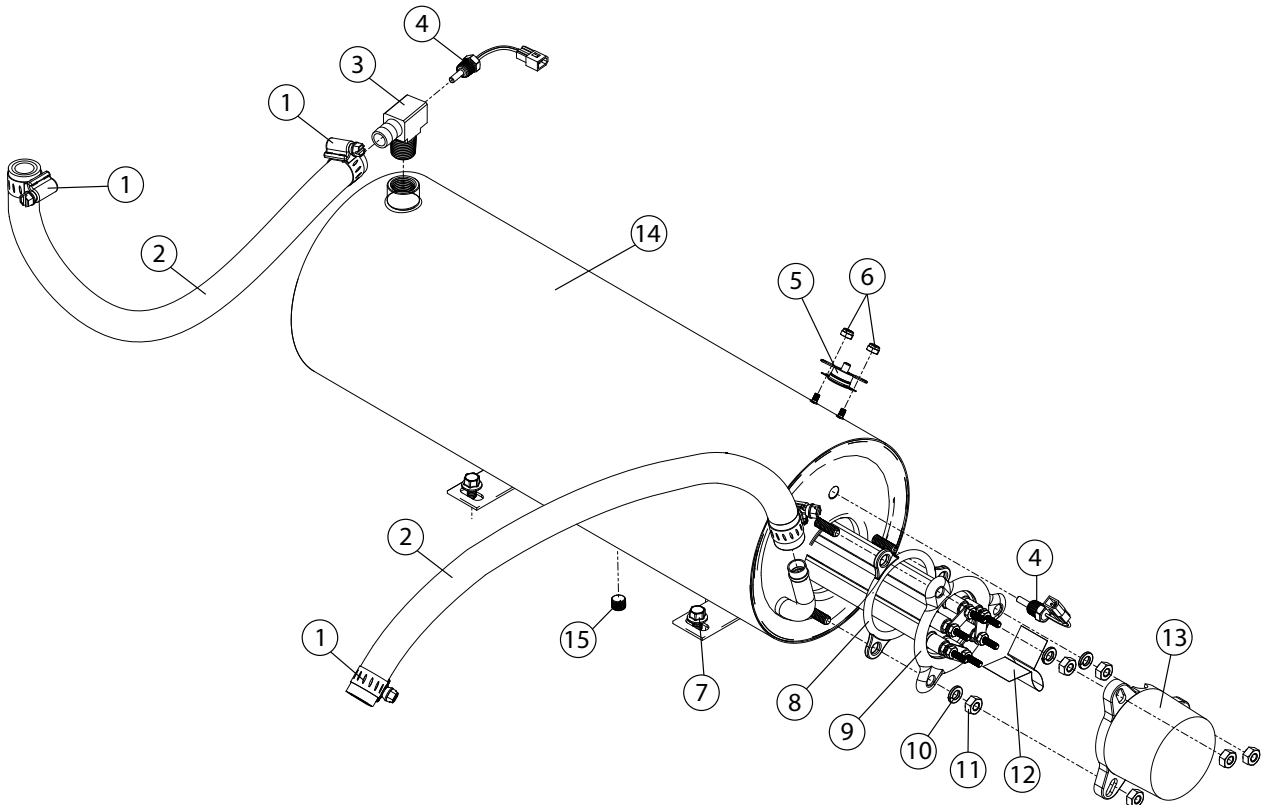

UH130B, UH230B - Booster Assembly

Item No.	Part No.	Description	Qty.
1	0512985	CLAMP, SS GEAR-MIN. 1/2"	4
2	107417	HOSE, RUBBER 1/2" ID X .84" OD	A/R
3	0513314	TEE, RINSE	1
4	0513310	THERMISTOR 10 kΩ, 2-WIRE	2
5	110562	THERMOSTAT, HIGH LIMIT 240°F	1
6	108954	NUT, GRIP 6-32 W/NYLON INSERT SST	2
7	0512185	BOLT, HEX FLANGE, 1/4-20 X 3/8" SST	2
8	109985	SEAL, BOOSTER ELEMENT	1
9	111235-1	BOOSTER, ELEMENT 5 KW, 40°F RISE	1
—	111233	BOOSTER, ELEMENT 9 KW, 70°F RISE	1
10	106482	WASHER, LOCK 1/4" SPLIT SST	3
11	100003	NUT, PLAIN 1/4-20 SST	6
12	111885	INSULATOR	1
13	107908	COVER, ELEMENT	1
14	0713333	TANK, BOOSTER SST	1
15	0508817	PLUG, 1/8"	1
—	0513538	HARNESS, BOOSTER CONTROL (<i>Not Shown</i>)	1

Power Input Block and Cord Assemblies - All Models

UH130, UH130B
UH230, UH230B
UH330B

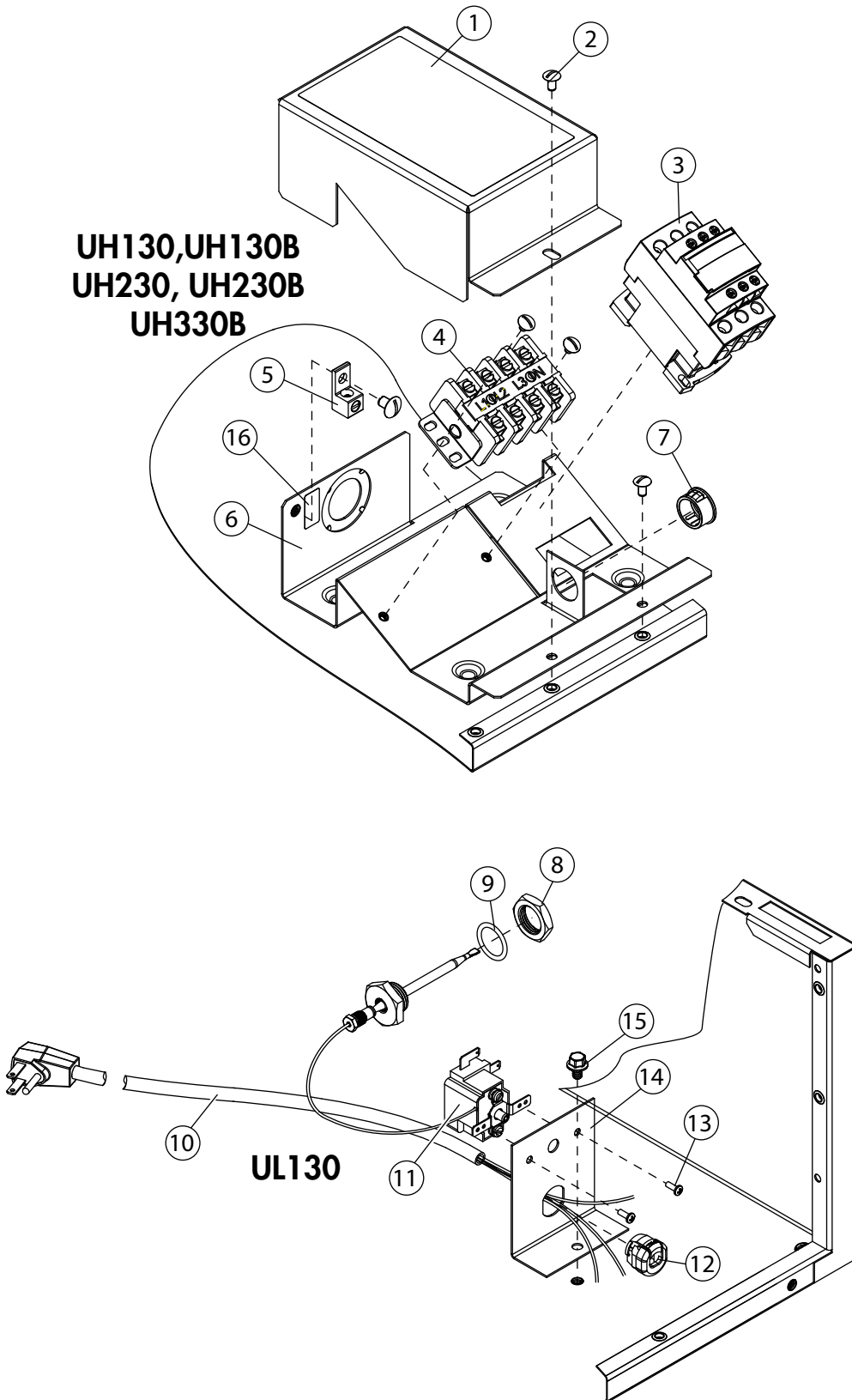

All Models - Power Input Block and Cord Assemblies

Item No.	Part No.	Description	Qty.
1	0313396	COVER, BOX WIRING	1
2	0501411	SCREW, 10-32 X 1/4", TRUSS HD.	2
3	0512432	CONTACTOR, 3-POLE 120VAC COIL	1
4	0509527	BLOCK, TERMINAL, 4-POLE <i>(All except UL130)</i>	1
5	103310	LUG, GROUND	1
6	0313395	BOX, WIRING	1
7	107964	BUSHING, STRAIN RELIEF, SMALL	A/R
8	201029-1	NUT, LOCK 1/2 INCH NI PLATED	A/R
9	0512099	O-RING	1
10	0513312	CORD AND PLUG, 115VAC <i>(UL130 Only)</i>	1
11	0507323	THERMOSTAT, WASH <i>(UL130 Only)</i>	1
12	0503647	RELIEF, STRAIN	1
13	0501450	SCREW, 6-32 X 3/16" NIBS, RH PHIL. SST	2
14	0313410	BRACKET, POWER CORD	1
15	0512185	BOLT, HEX FLANGE, 1/4-20 X 3/8" SST	1
16	0503592	LABEL, GROUND	1

Timer Control Board Assembly - UH130B, UH230B, UH330B

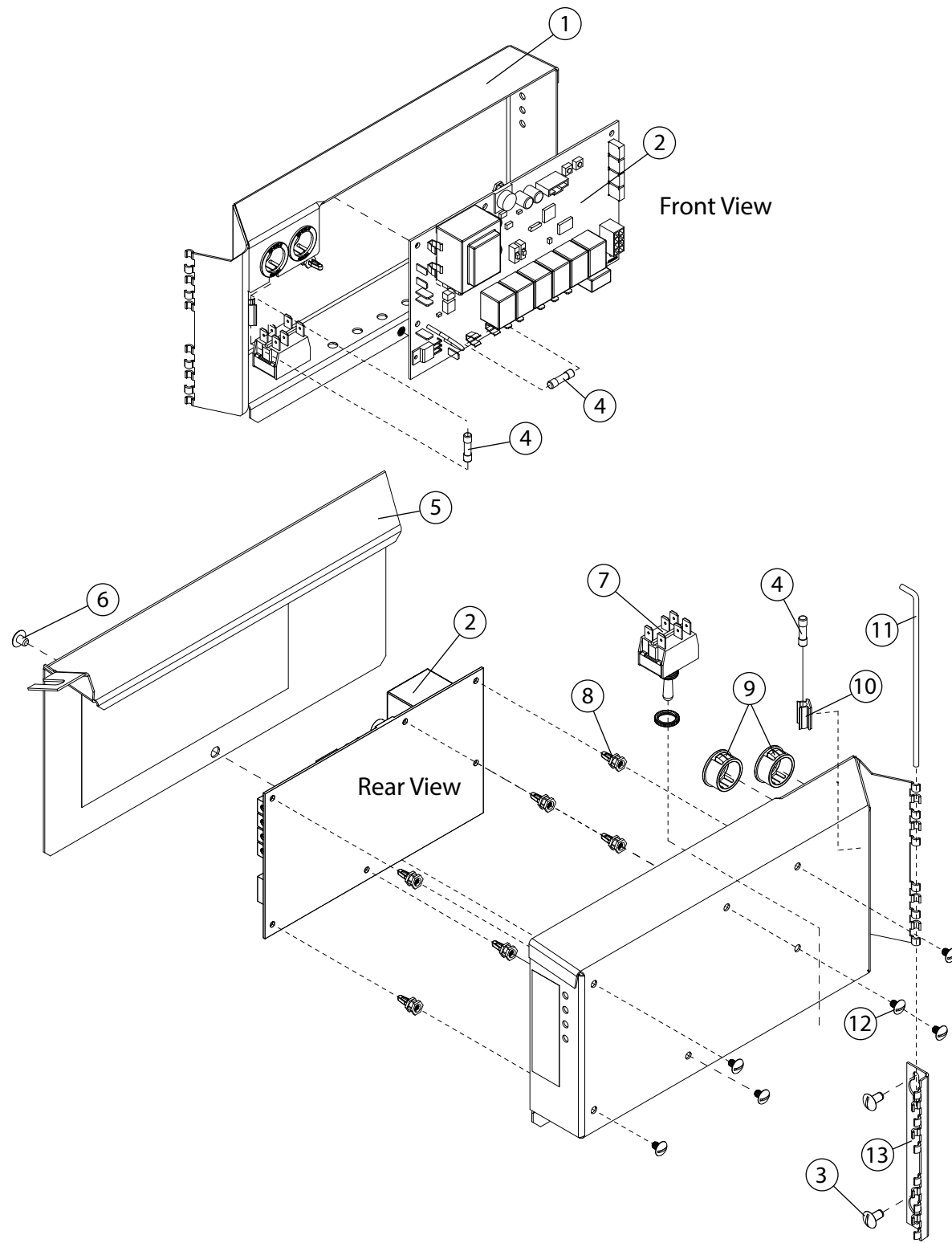

UH130B, UH230B, UH330B - Timer Control Board Assembly

Item No.	Part No.	Description	Qty.
1	0313397	BOX, CONTROL BOARD (ALL EXCEPT UH330B)	1
–	0313397-1	BOX, CONTROL BOARD (UH330B ONLY)	1
2	0712105	TIMER CKT. BD. (ALL EXCEPT UH330B)	1
–	0513575	TIMER CKT. BD. (UH330B ONLY)	1
3	0501464	SCREW, 10-24 X 3/8; TRUSS HD. SST	2
4	0512373	FUSE, 4A 250V (ALL EXCEPT UH330B)	1
–	0513698	FUSE, 6A 250V (UH330B ONLY)	1
5	0313398	COVER, BOX (ALL EXCEPT UH330B)	1
–	0313398-1	COVER, BOX (UH330B ONLY)	1
6	0501411	SCREW, 10-32 X 1/4" SST	1
7	0501373	SWITCH, BOOSTER FILL	1
8	0512973	STANDOFF	6
9	107964	BUSHING, STRAIN RELIEF	2
10	0512781	HOLDER, FUSE	1
11	0313644	PIN, HINGE	1
12	0501408	SCREW, 8-32 X 1/4" TRUSS HD. PHIL. SST	6
13	0313431	BRACKET, HINGED PANELS	1

Wash and Rinse Spray Arms and Drain Valve - UH230, UH230B, UH330B

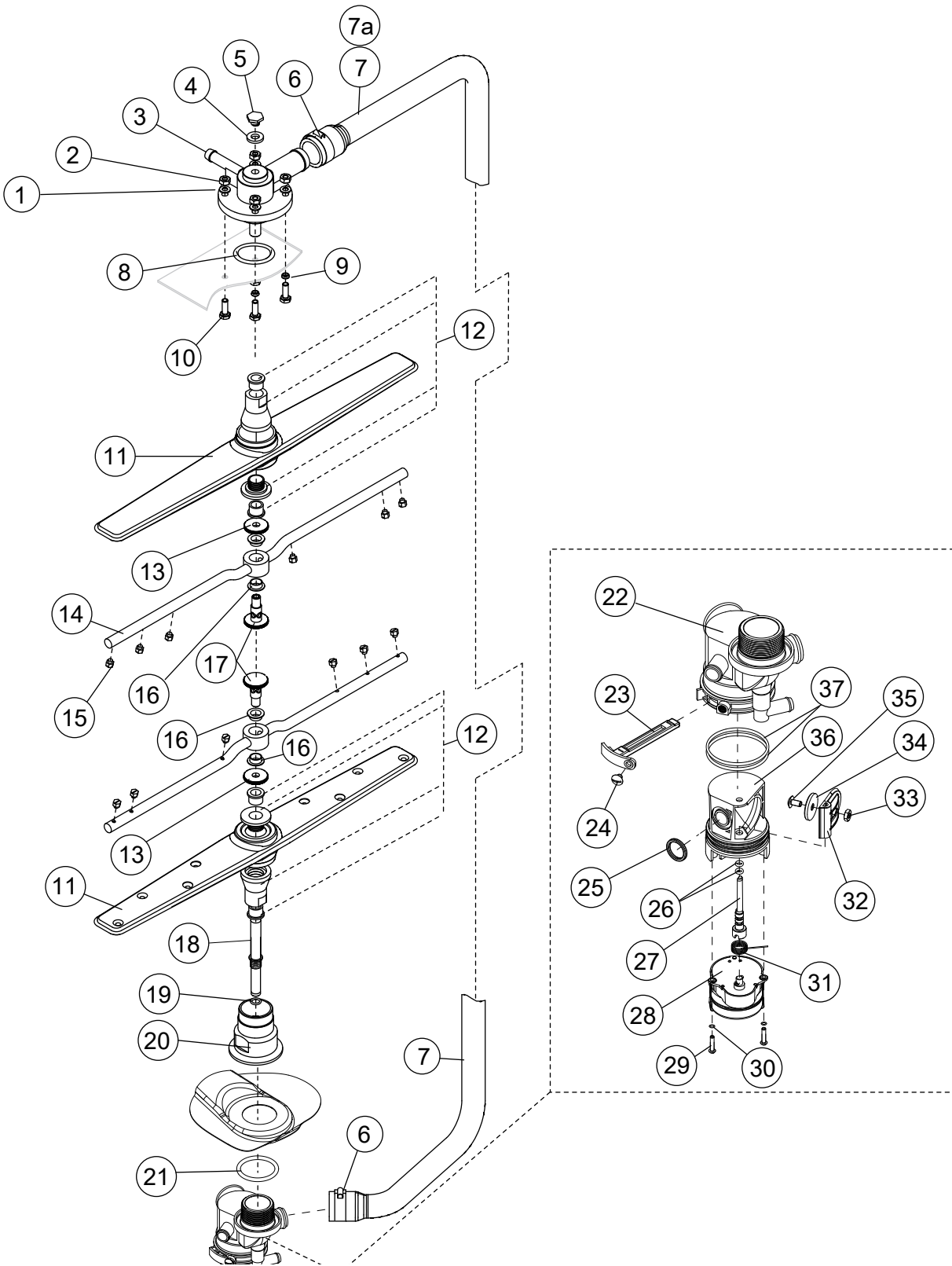

UH230, UH230B, UH330B - Wash and Rinse Spray Arms and Drain Valve

Item No.	Part No.	Description	Qty.
1	0501478	WASHER, 17/64 id X 9/16" OD SST	4
2	107967	NUT, HEX 1/40-20 NYLON INSERT SST	4
3	0514251-1	HUB, UPPER SPRAY ARMS	1
4	107873	WASHER, PACKING	1
5	110215	SCREW, RETAINING	1
6	0502571	CLAMP, HOSE GEAR 1-1/2" SST	2
7	0512120	HOSE, UPPER WASH ARM (UH230, UH230B)	1
7a	0513699	HOSE, UPPER WASH ARM (UH330B)	1
8	0512133	O-RING, 2-1/8" OD X 1-3/4" ID X 3/16"	1
9	0501481	WASHER, NYLITE	4
10	100738	BOLT, 1/4-20 X 1" SST	4
11	H420548	WASH ARM ASSEMBLY (Includes Item 12)	2
12*	0712749	BEARING ASSEMBLY	2
13	H34998	NUT, SPACER	2
14	H36211	RINSE ARM ASSEMBLY (Includes Items 13, 16, and 17)	2
15	H37149	NOZZLE, RINSE ARM	12
16	H190663	BEARING, RINSE ARM	4
17	H36275	SPINDLE, RINSE ARM	2
18	0512124	SHAFT, LOWER	1
19	0512239	O-RING	1
20	0512066	HUB, LOWER WASH ARM	1
21	0512133	O-RING, 2-1/8" OD X 1-3/4" ID X 3/16"	1
22	0513439	HOUSING, MANIFOLD FWR	1
23	0513443	PIN, RETENTION	1
24	0509439	SCREW, RETENTION PIN 10-32 X 5/16" SST	1
25	0513446	O-RING, QUAD	1
26	0513445	O-RING, PIVOT SHAFT	2
27	0513447	SHAFT, FLAPPER	1
28	0712123	MOTOR, DRAIN VALVE	1
—	0509257	PIN, MOTOR (COMES WITH MOTOR)	1
29	104883	SCREW, MOTOR 6-32 X 3/8" SST	2
30	0501497	WASHER, SPLIT LOCK #8	2
31	0512126	SPRING, TORSION	1
32	0513442	FLAPPER	1
33	100194	NUT, FLAPPER SEAL 10-32 SST	1
34	0512127	GASKET, FLAPPER	1
35	100007	SCREW, FLAPPER SEAL 10-32 X 3/8" RD.HD. SST	1
36	0513441	BODY, CARTRIDGE DRAIN VALVE	1
37	0513444	O-RING, CARTRIDGE BODY	2
—	0713667	CARTRIDGE ASSEMBLY, DRAIN VALVE COMPLETE INCLUDES ITEMS 23-37	1

* Note:

The bearing assembly, P/N 0712749 includes 2 bearings, 1 locknut, and 1 wash arm hub. The bearings, locknut and hub are not available as separate service replacement parts.

Wash/Rinse Spray Arm and Drain Valve - UH130, UH130B, UL130

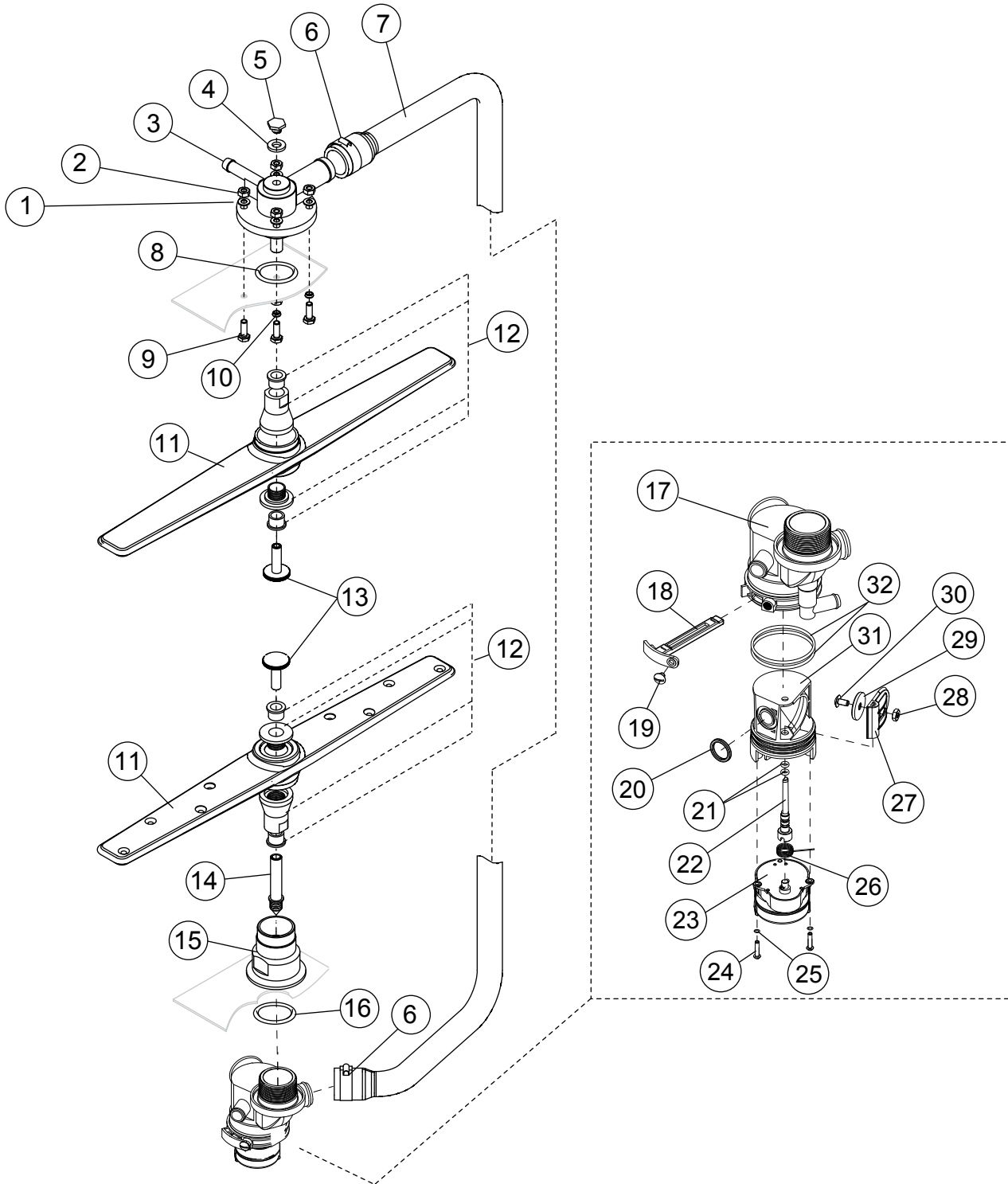

UH130, UH130B, UL130 - Wash/Rinse Spray Arm and Drain Valve

Item No.	Part No.	Description	Qty.
1	0501478	WASHER, 17/64" ID X 9/16" OD SST	4
2	107967	NUT, HEX SST 1/4-20 NYLON INSERT	4
3	0514251	HUB, UPPER WASH ARM	1
4	107873	WASHER, PACKING	1
5	110215	SCREW, RETAINING	1
6	0502571	CLAMP, HOSE GEAR HOSE 1-1/2" SST	2
7	0512120	HOSE, UPPER WASH ARM	1
8	0512133	O-RING, 2-1/8" OD X 1-3/4" ID X 3/16	1
9	100738	BOLT, 1/4-20 X 1" HEX. HD. SST	4
10	0501481	WASHER, NYLTITE	4
11	H420548	WASH ARM ASSEMBLY <i>(Includes Item 12)</i>	2
12*	0712749	BEARING ASSEMBLY	2
13	0512129	NUT, WASH ARM	2
14	0512125	SHAFT, LOWER	1
15	0512066	HUB, LOWER WASH ARM	1
16	0512133	O-RING, 2-1/8" OD X 1-3/4" ID X 3/16	1
17	0513440	HOUSING, MANIFOLD	1
18	0513443	PIN, RETENTION	1
19	0509439	SCREW, RETENTION PIN 10-32 X 5/16" SST	1
20	0513446	O-RING, QUAD	1
21	0513445	O-RING, PIVOT SHAFT	2
22	0513447	SHAFT, FLAPPER	1
23	0712123	MOTOR, DRAIN VALVE	1
—	0509257	PIN, MOTOR (COMES WITH MOTOR)	1
24	104883	SCREW, MOTOR 6-32 X 3/8" SST	2
25	0501497	WASHER, SPLIT LOCK #8	2
26	0512126	SPRING, TORSION	1
27	0513442	FLAPPER	1
28	100194	NUT, FLAPPER SEAL	1
29	0512127	GASKET, FLAPPER	1
30	0501412	SCREW, FLAPPER SEAL 10-32 X 3/8"	1
31	0513441	BODY, CARTRIDGE DRAIN VALVE	1
32	0513444	O-RING, CARTRIDGE BODY	2
—	0713667	CARTRIDGE ASSEMBLY, COMPLETE INCLUDES ITEMS 18-32	1

* Note:

The bearing assembly, P/N 0712749 includes 2 bearings, 1 locknut, and 1 wash arm hub.
The bearings, locknut and hub are not available as separate service replacement parts.

Control Panel - UH130, UH130B

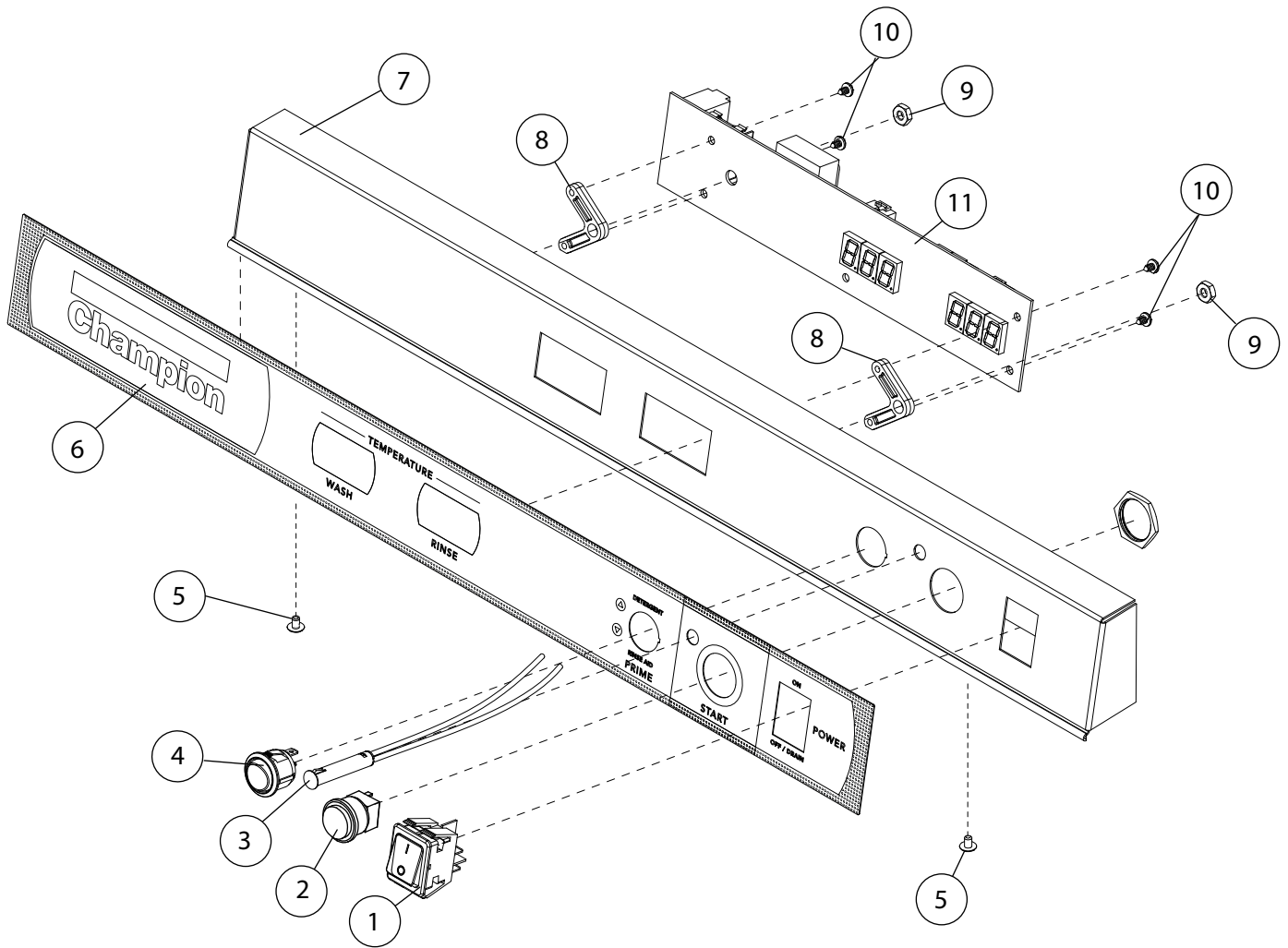

Note:
This version obsolete after S/N 190183363
See page 50-51 for current version

UH130, UH130B - Control Panel

Item No.	Part No.	Description	Qty.
1	0512221	SWITCH, ROCKER DPST 250V NEON	1
2	0512214	SWITCH, PUSH-BUTTON, GREEN	2
3	0512232	LIGHT, INDICATOR, GREEN	2
4	0512226	SWITCH, ROCKER RND SPDT MOMENTARY	1
5	0501408	SCREW, TRUSS PHIL. SST 8-32 X 1/4"	2
6	0513540	LABEL, FACIA	1
7	0313418	PANEL, FACIA	1
8	0512357	STANDOFF, LED DISPLAY BOARD	2
9	0503580	NUT, 10-32	2
10	0501563	SCREW, #8 X 3/8"	4
11	0712106	TEMPERATURE INDICATOR BD., DIGITAL	1
-	0512362	HARNESS, DIGITAL DISPLAY <i>(Not Shown)</i>	1
-	0513538	HARNESS, BOOSTER CONTROL <i>(Not Shown)</i>	1
-	0513361	HARNESS, MACHINE <i>(Not Shown)</i> (Does not include Booster or Digital display harness)	1

Note:

This version obsolete after S/N 190183363

See page 50-51 for current version

Control Panel - UH230, UH230B, UH130, UH130B beginning with S/N 190183364

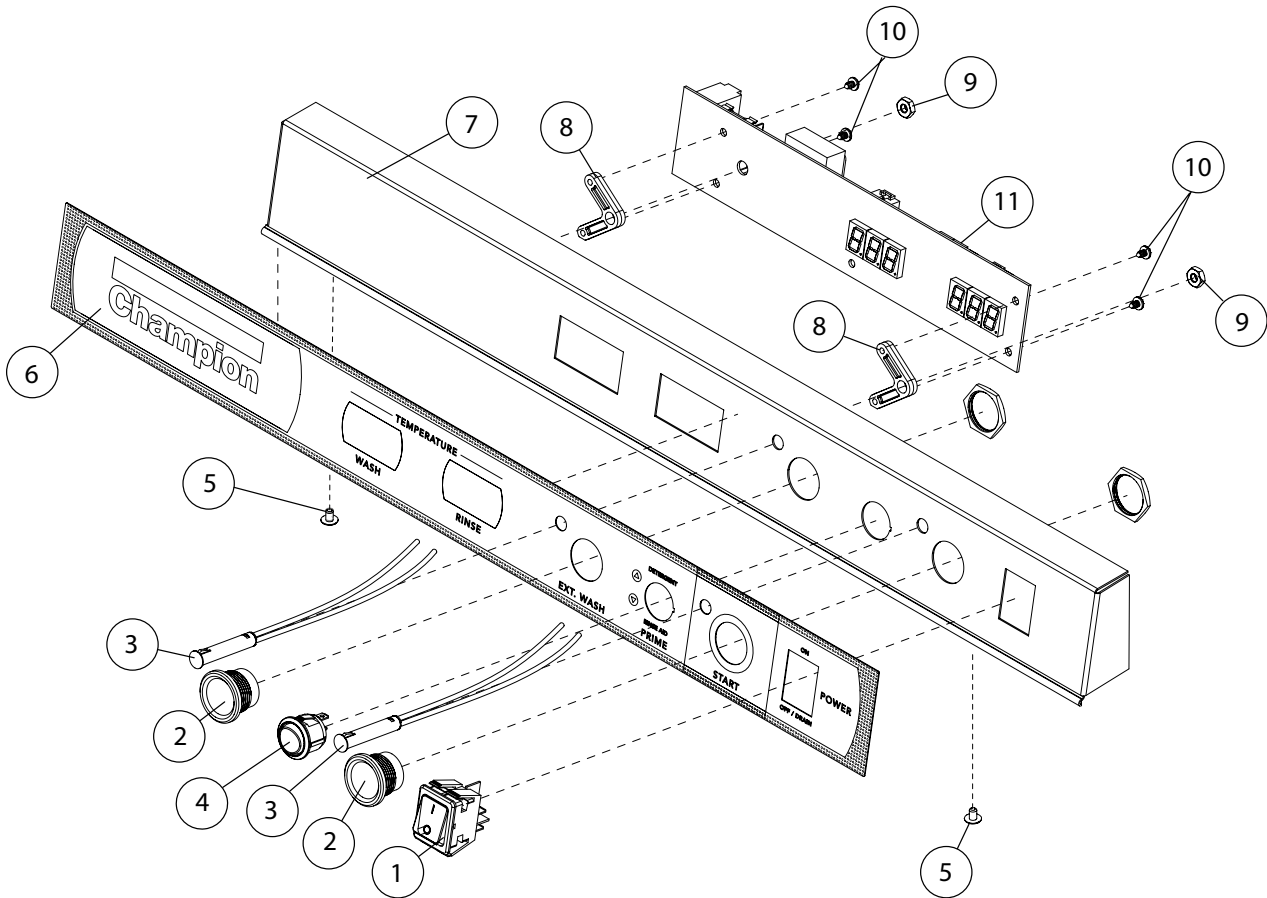

UH230, UH230B, UH130, UH130B beginning with S/N 190183364 - Control Panel

Item No.	Part No.	Description	Qty.
1	0512221	SWITCH, ROCKER DPST 250V NEON	1
2	0512213	SWITCH, PIEZIO	2
3	0512232	LIGHT, INDICATOR, GREEN	2
4	0512226	SWITCH, ROCKER RND SPDT MOMENTARY	1
5	0501408	SCREW, TRUSS PHIL. SST 8-32 X 1/4"	2
6	0513539	LABEL, FACIA	1
7	0313417	PANEL, FACIA	1
8	0512357	STANDOFF, LED DISPLAY BOARD	2
9	0503580	NUT, 10-32	2
10	0501563	SCREW, #8 X 3/8"	4
11	0712106	TEMPERATURE INDICATOR BD., DIGITAL	1
-	0512362	HARNESS, DIGITAL DISPLAY <i>(Not Shown)</i>	1
-	0513538	HARNESS, BOOSTER CONTROL <i>(Not Shown)</i>	1
-	0513361	HARNESS, MACHINE <i>(Not Shown)</i> (Does not include Booster or Digital display harness)	1

Control Panel - UH330B

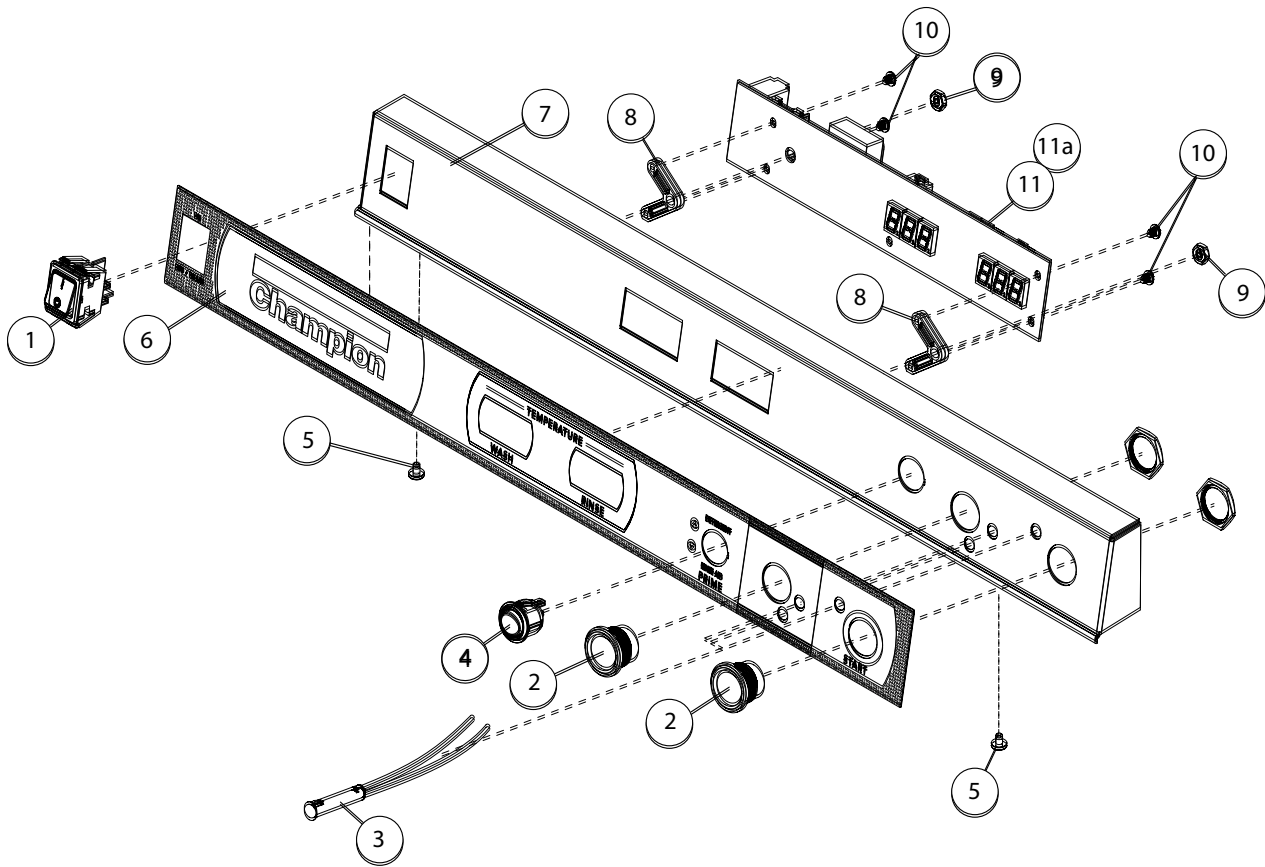

Item No.	Part No.	Description	Qty.
1	0512221	SWITCH, ROCKER DPST 250V NEON	1
2	0512213	SWITCH, PIEZIO	2
3	0512232	LIGHT, INDICATOR, GREEN	3
4	0512226	SWITCH, ROCKER RND SPDT MOMENTARY	1
5	0501408	SCREW, TRUSS PHIL. SST 8-32 X 1/4"	2
6	0513579	LABEL, FACIA Prior to S/N W1606059926	1
-	0513579-1	LABEL, FACIA Beginning with S/N W160659926	1
7	0713583	PANEL, FACIA Prior to S/N W1606059926	1
-	0313415	PANEL, FACIA Beginning with S/N W160659926	1
8	0512357	STANDOFF, LED DISPLAY BOARD	2
9	0503580	NUT, 10-32	2
10	0501563	SCREW, #8 X 3/8"	4
11	0712106	TEMPERATURE INDICATOR BD., DIGITAL, UH330B M4 Prior to S/N W170568116	1
11a	0514315	TEMPERATURE INDICATOR BD., DIGITAL, UH330B M4.2 Beginning with S/N W170568116 and above	1
-	0512362	HARNESS, DIGITAL DISPLAY <i>(Not Shown)</i>	1
-	0513538	HARNESS, BOOSTER CONTROL <i>(Not Shown)</i>	1
-	0513576	HARNESS, MACHINE M4.0 <i>(Not Shown)</i> (Does not include Booster or Digital display harness)	1
-	0514294	HARNESS, MACHINE M4.2 <i>(Not Shown)</i> (Does not include Booster or Digital display harness)	1

Control Panel - UL130

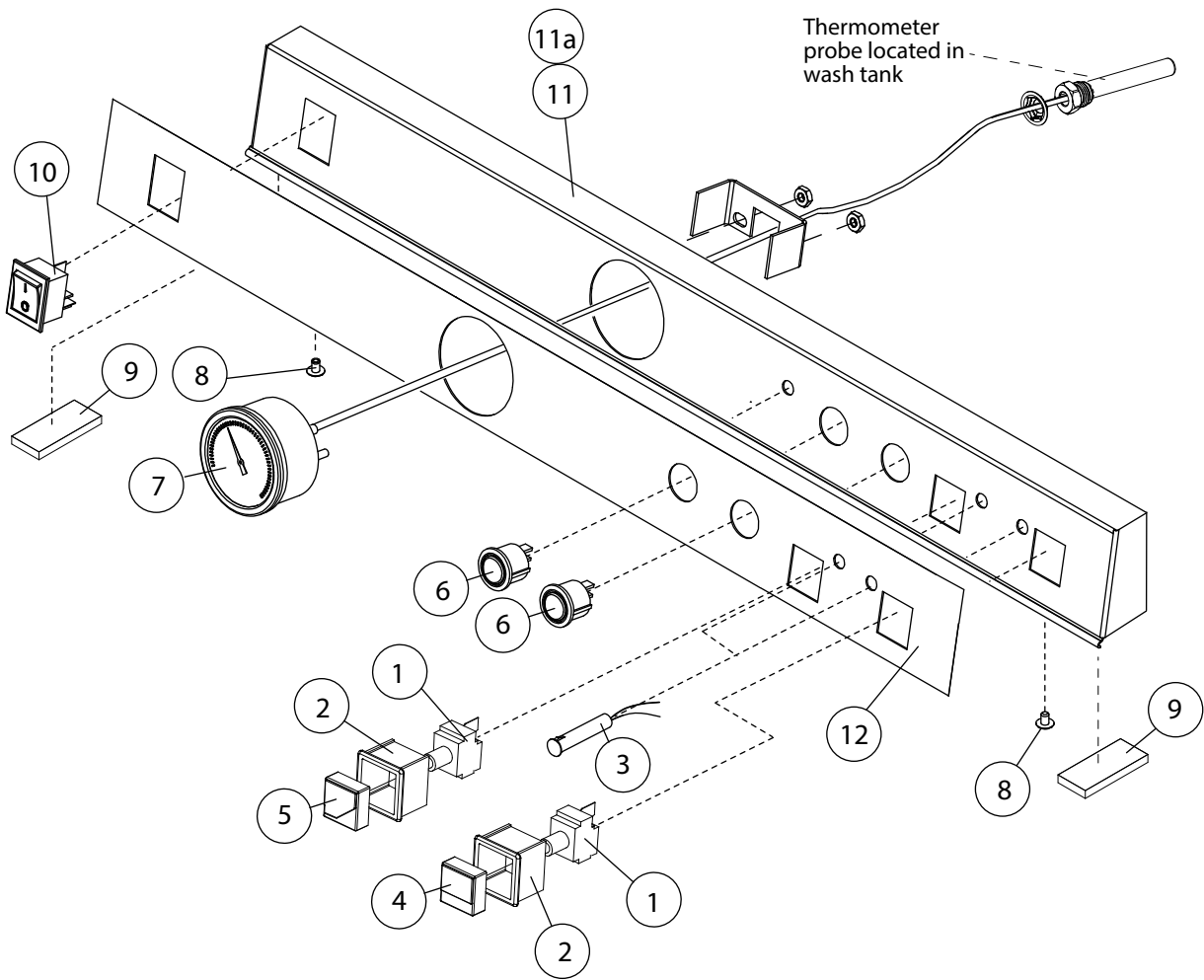

Item No.	Part No.	Description	Qty.
1	0512216	CONTACT, SWITCH MOMENTARY (N.O.)	2
2	0512217	HOUSING, PUSH BUTTON SWITCH	2
3	0512232	LIGHT, INDICATOR, GREEN	2
4	0512218	PUSH BUTTON, GREEN	1
5	0512219	PUSH BUTTON, GRAY	1
6	0512226	SWITCH, ROCKER RND SPDT MOMENTARY	2
7	0512107	THERMOMETER, 2" DIAL, 7" CAPILLARY	1
8	0501408	SCREW, TRUSS PHIL. SST 8-32 X 1/4"	2
9	0512320	GASKET, STEAM	1
10	0512220	SWITCH, ROCKER DPST 125V NEON	1
11	0313419	PANEL, FACIA (Prior to S/N W20036317)	1
12	0513515	LABEL, FACIA PANEL, (Beginning with S/N W191293567)	1

Panels- UH130, UH130B, UH230, UH230B, UL130

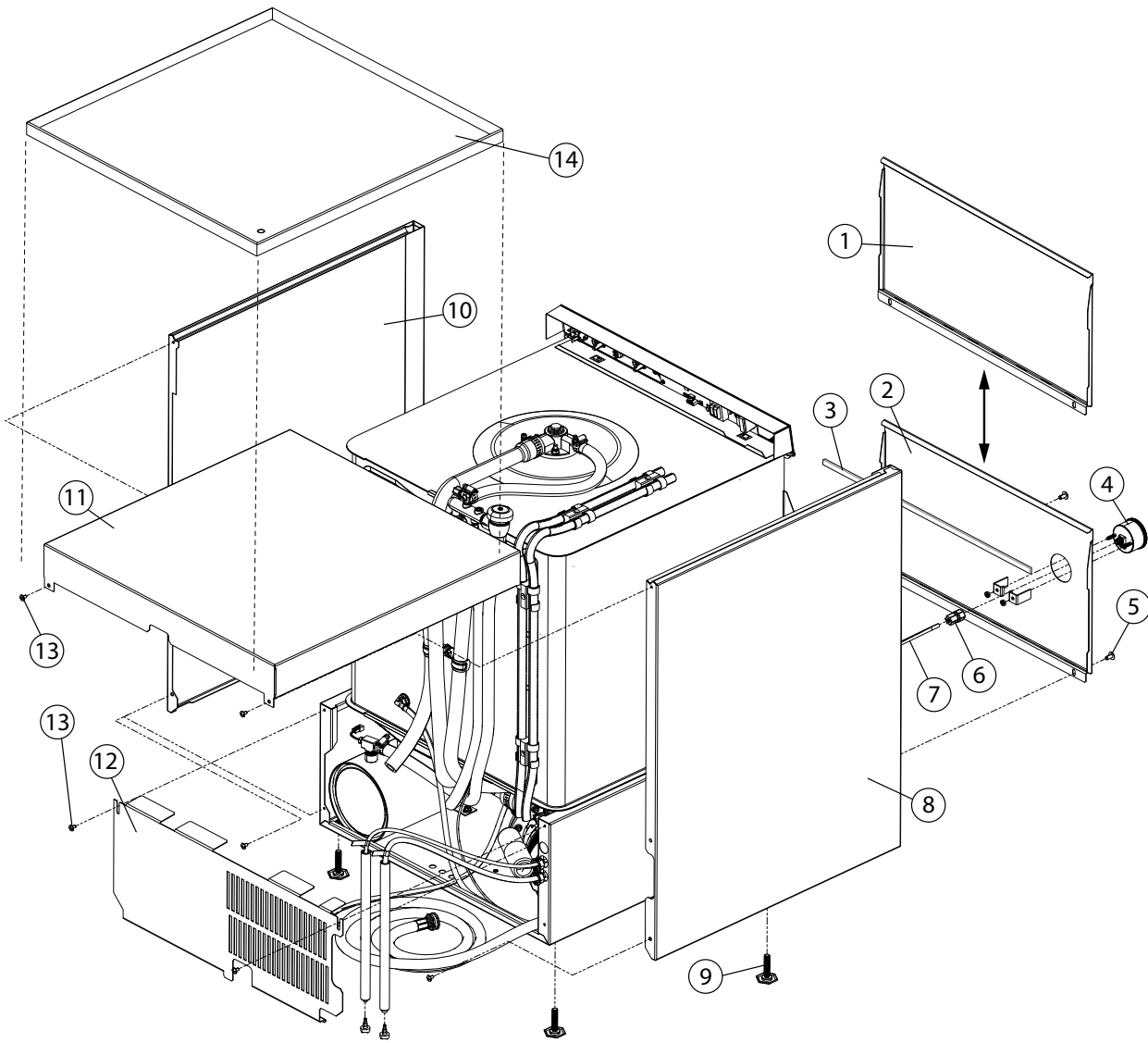

UH130, UH130B, UH230, UH230B, UL130 - Panels

Item No.	Part No.	Description	Qty.
1	0313406	PANEL, FRONT WITHOUT GAUGE HOLE	1
2	0313407	PANEL, FRONT WITH GAUGE HOLE	1
3	0512319	GASKET, 1/8" x 5/8" x 21-1/2"	1
4	109812	GAUGE, PRESSURE 0-60 PSI	1
5	100779	SCREW 1/4-20 X 5/8" TRUSS SS PHIL	A/R
6	0513659	FITTING, 1/4" TUBE X 1/8" FNPT PP	1
7	107928	TUBING, 1/4" NATURAL	A/R
8	0313403	PANEL, LH SIDE	1
9	0503718	FOOT, ADJUSTING	4
10	0313402	PANEL, RH SIDE	1
11	0313401	PANEL, TOP	1
12	0313404	PANEL, REAR	1
13	100007	SCREW, TRUSS SLOT SST 10-32 X 3/8"	A/R
14	0714208	KIT, DRIP TRAY (See page 64)	A/R

Panels - UH330B

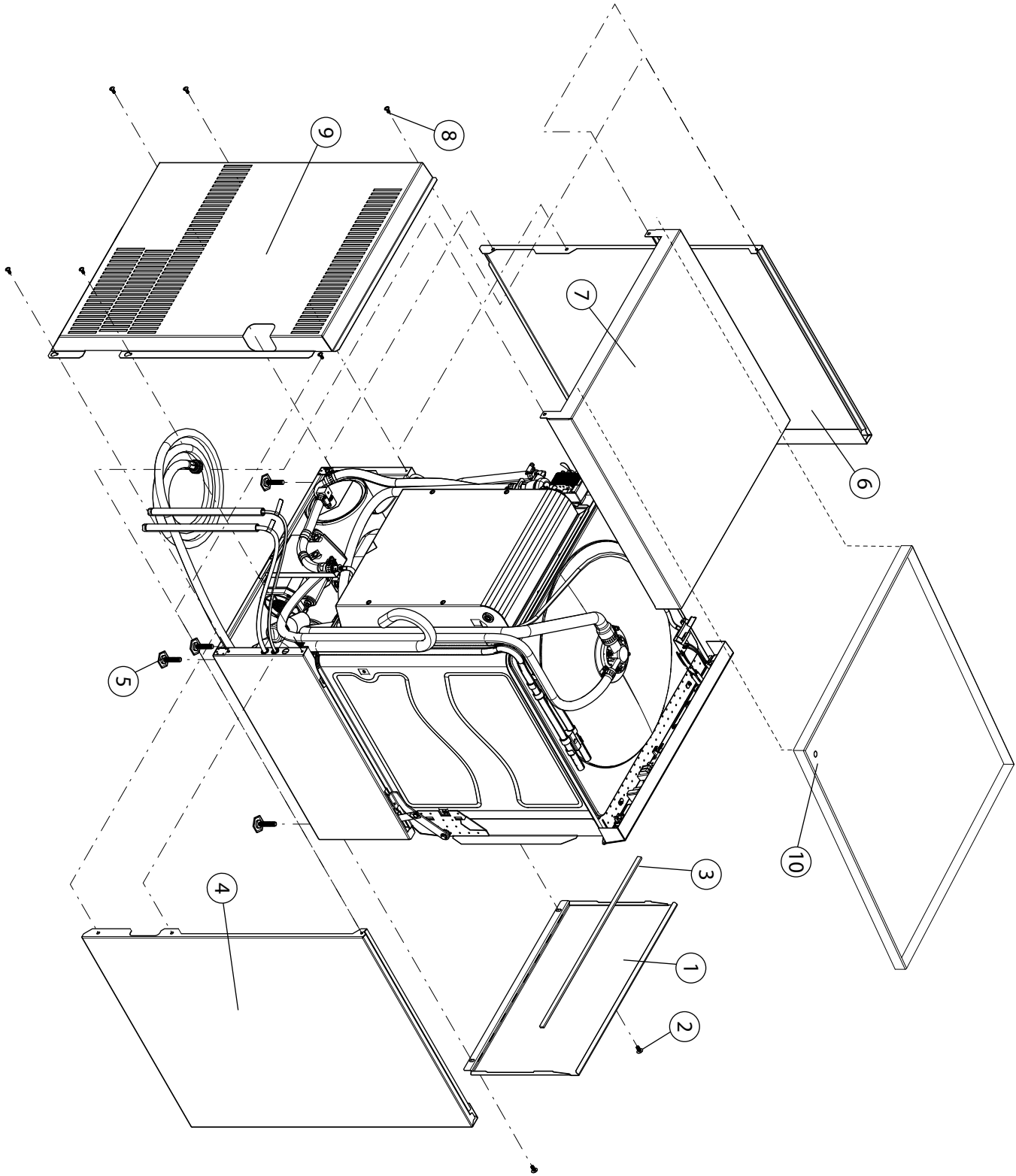

Item No.	Part No.	Description	Qty.
1	0313406	PANEL, FRONT Prior to S/N W160659926	1
-	0313405	PANEL, FRONT Beginning with S/N W160659926	1
2	100779	SCREW 1/4-20 X 5/8" TRUSS SS PHIL	A/R
3	0512319	GASKET, 1/8" X 5/8" X 21-1/2"	1
4	0313403	PANEL, LH SIDE	1
5	0503718	FOOT, ADJUSTING	4
6	0313402	PANEL, RH SIDE	1
7	0313584	PANEL, TOP Prior to S/N W160659926	1
-	0313584-1	PANEL, TOP Beginning with S/N W160659926	1
8	100007	SCREW, TRUSS SLOT SST 10-32 X 3/8"	A/R
9	0313626	PANEL, REAR	1
10	0714208	KIT, DRIP TRAY (See page 64)	A/R

Door Assembly - All Models

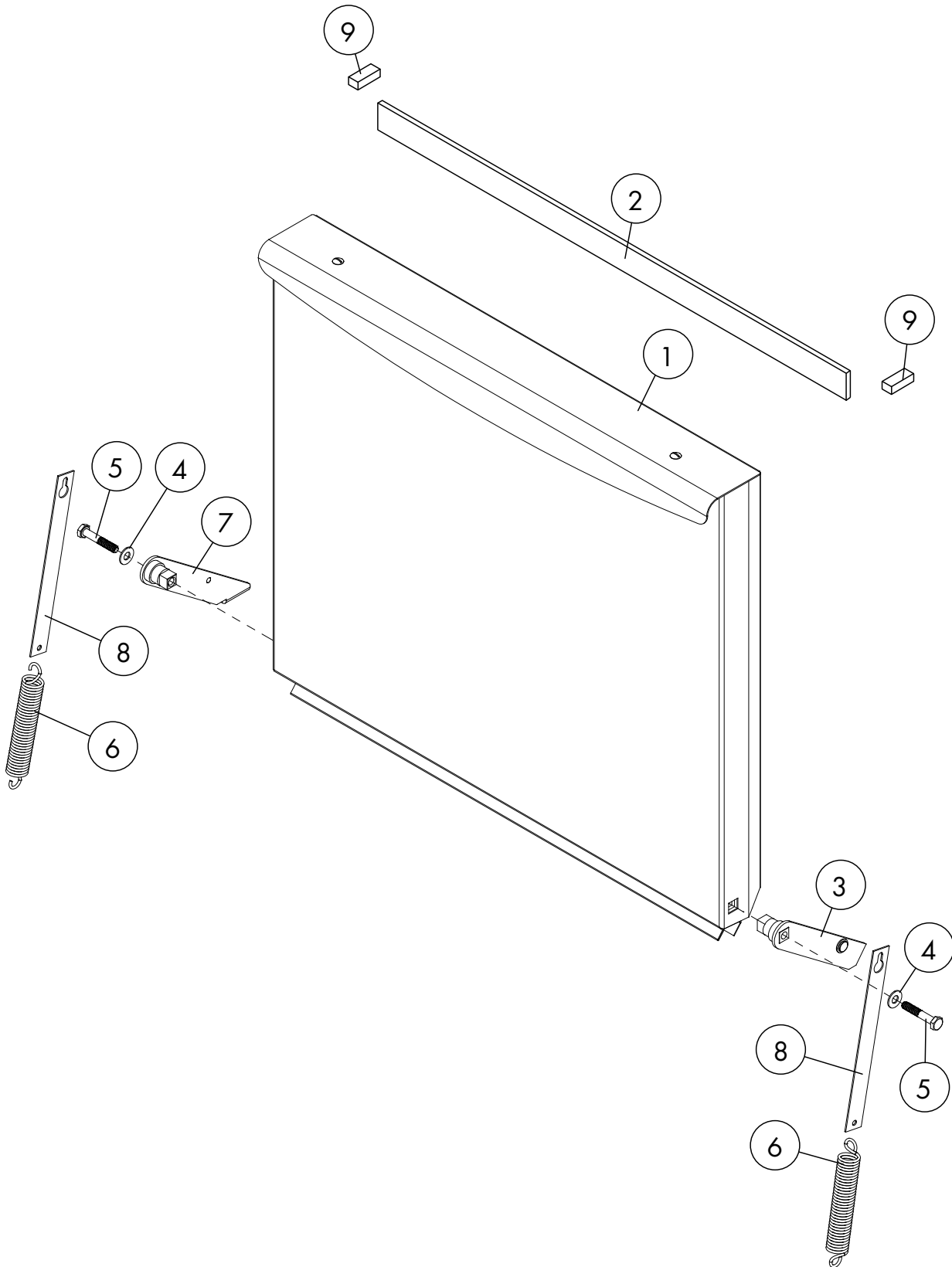

All Models - Door Assembly

Item No.	Part No.	Description	Qty.
1	0713136	DOOR ASSEMBLY	1
2	0513558	GASKET, DOOR TOP	1
3	0713428	HINGE, RH ASSY	1
4	0501476	WASHER, 9/32" X 5/8" OD SS	1
5	0501422	BOLT, HEX SS 1/4-20 X 1-1/2"	1
6	0513332	SPRING, DOOR	2
7	0713429	HINGE, LH ASSY	1
8	0313430	ARM, DOOR SPRING	2
9	0512320	GASKET, STEAM	2

Dish Racks, Line Strainer, PRV

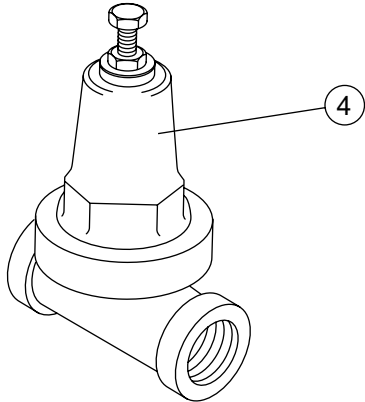
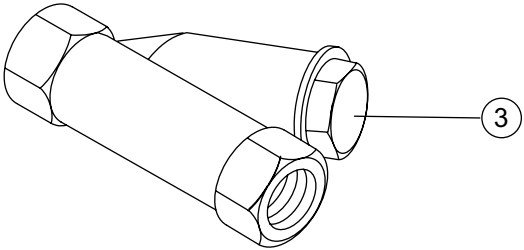
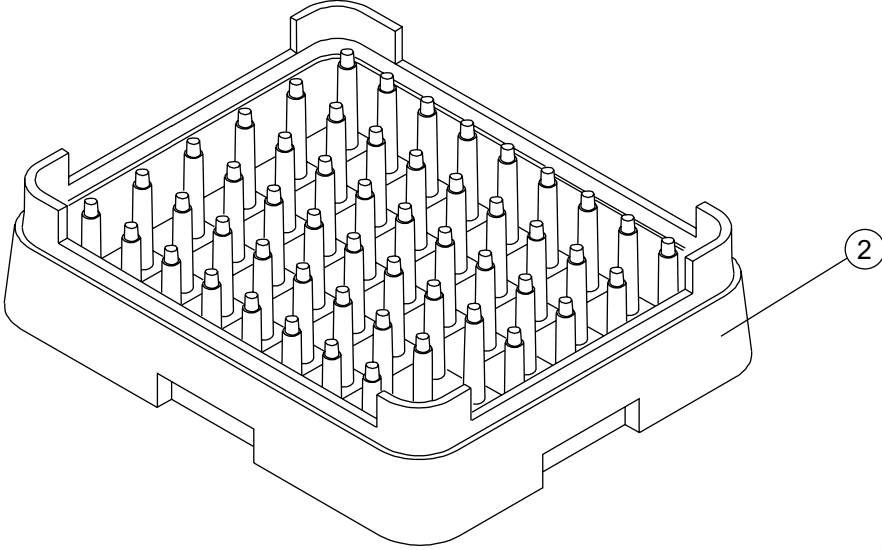
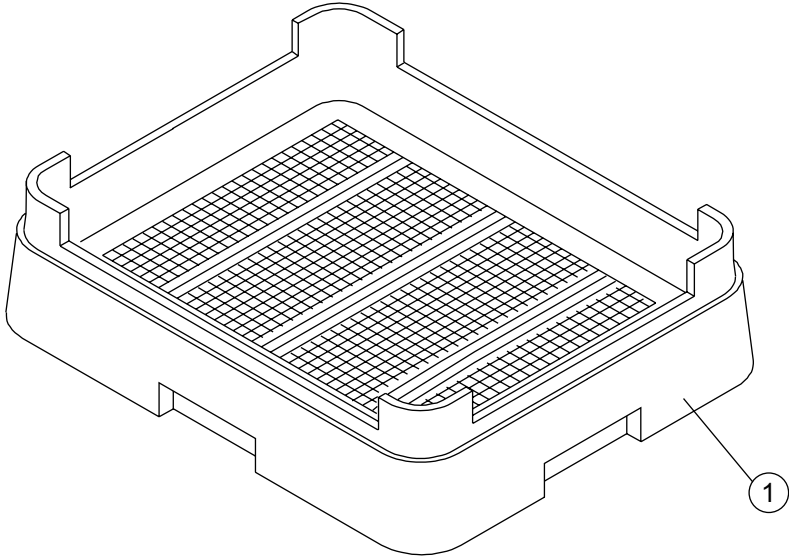

Dish Racks, Line Strainer, PRV

Item No.	Part No.	Description	Qty.
1	101273	DISH RACK, FLAT-BOTTOM	AR
2	101285	DISH RACK, PEG	AR
3	104421	STRAINER, LINE 1/2" BRONZE (UH230, UH230B)	1
4	108265	VALVE, PRESSURE REGULATING (PRV) (UH230, UH230B)	1



MDL PART NO. 0714208



*****WARNING*****

****STORING WET DISH RACKS DIRECTLY ON TOP OF THE MACHINE WITHOUT A DRIP TRAY KIT INSTALLED WILL VOID WARRANTY****