

Cleveland

Operation Manual

STEAMCUB



MODELS: 1SCE
1SCEMCS

1SCE-OPM

FOR THE USER

FOR YOUR SAFETY

Do not Store or use gasoline or other flammable vapors or liquids in the vicinity of this or any other appliance.

WARNING

Disconnect power before servicing

WARNING

Improper installation, adjustment, alterations, services or maintenance can cause property damage, injury or death. Read the installation, operating and maintenance instructions thoroughly before installing or servicing this equipment.

IMPORTANT

ALL SERVICE MUST BE PERFORMED BY A QUALIFIED CLEVELAND RANGE TECHNICIAN.

RETAIN THIS MANUAL FOR YOUR REFERENCE

Operators and Installation Manual
 SteamCub Steam Cooker, Holding Cabinet and Rethermalization Unit
Table of Contents

<u>CHAPTER</u>	<u>PAGE</u>
CHAPTER 1. INTRODUCTION	1
A. Operational Safety.....	1
B. Product Information	2
1. Model Number.....	2
2. Serial No	2
3. Product information Plate	2
4. "SteamCub" Model 1SCE Product View	3
 CHAPTER 2. OPERATION	 4
A. GENERAL OPERATION	4
1. Main Power Switch.....	4
2. Door Interlock Switch.....	4
3. Inspecting the Cooking Compartment – Manual Water Fill.....	4
4. Power ON (Automatic Preheat).....	5
5. Preheating the Steamer.....	5
6. Low Water Alarm.....	5
B. CONTROL PANEL OPERATION.....	5
Cooking Modes – Constant Steam Cooking, Holding and Timed Cooking	
1. Constant Steam Mode.....	5
2. Holding Only Mode.....	7
3. Timed Cook and Hold Mode and use of the Timer.....	7
a. General Operation.....	7
b. Setting and using the Timer.....	7
4. Display Temperature Function.....	8
C. COOKING WITH THE STEAMCUB.....	8
1. Operating and Cooking Procedure – Steam and Hold Mode.....	8
2. Operating and Cooking Procedure – Constant Steam Mode.....	9
a. Control Operation in Constant Steam Mode.....	10
b. Constant Steam Cooking Procedure.....	10
3. Operating Procedure – Hold Only Mode.....	11
a. Control Operation in Hold Only Mode.....	11
b. Using the Hold Only Mode.....	11
4. Using the SteamCub to Rethermalize Food.....	12
D. SHUTDOWN AND CLEANING PROCEDURE.....	12
 CHAPTER 3 – PREVENTATIVE MAINTENANCE AND TROUBLESHOOTING.....	 14
A. MAINTENANCE.....	14
1. Maintenance Records.....	14
2. Daily Maintenance.....	14
a. Checking and Changing the Water.....	14
b. Cleaning the Steamer.....	15
B. OPERATORS TROUBLESHOOTING GUIDE.....	15

(Continued on Following Page)

Table of Contents (continued)

<u>CHAPTER</u>	<u>PAGE</u>
CHAPTER 4 – INSTALLATION.....	17
A. GENERAL.....	17
B. INSTALLATION OF THE STEAMCUB.....	17
1. Locating the Steamer.....	17
a. Location and Clearance Requirements.....	17
b. Positioning and Leveling the Steamer.....	19
c. Installation Using Cleveland Range Stand No. ES-21301.....	19
2. Install Slide racks.....	19
3. Install Electric Power Lines.....	20
C. STARTUP AND CHECKOUT.....	21
1. Installation Checkout.....	21
2. Operating Test and Final Checkout Procedure.....	22
a. Startup Procedure.....	22
b. Steam and Hold Operation.....	22
c. Constant Steam Mode.....	23
d. Hold Mode.....	23

CHAPTER 1 – INTRODUCTION

To use a SteamCub steamer safely and effectively, each operator must read and understand this Section completely before starting operation. The owners and operators of the steamer should retain these instructions in an easily accessible location for future reference and training.

The owner(s) and operator(s) of the steamer must be aware that steam can cause serious injuries and equipment damage. Pay particular attention to the Operational Safety section of this chapter, and the WARNINGS and CAUTIONS displayed in this manual and on the equipment.

 WARNING
DO NOT ATTEMPT TO START OR OPERATE a SteamCub steamer during a power outage. DEATH, INJURY, AND EQUIPMENT DAMAGE could result from the improper installation of a steamer. Before starting a recently installed or repaired steamer, be sure it has been installed by qualified personnel according to the instructions found in CHAPTER 4 of this Manual.

A. OPERATIONAL SAFETY

The safe and effective operation of any steamer depends upon proper installation, use, maintenance, and repair. Operational safety must encompass all of these factors. This Operational Safety section outlines the minimum safety policies that should be considered when using one or more SteamCub steamers. It is assumed that any operational safety program must be tailored to the specific site and use of the equipment.

Burn hazards are present in any professional food service operation. When using the steamer, observe the following precautions.

- The SteamCub is a constantly cooking appliance and is some cooking mode whenever it is turned ON. As such parts of this appliance will **ALWAYS BE HOT**.
- Remember at all times that steam can cause severe burns.
- Open the door slightly to allow steam to vent before looking or reaching into cooking compartment.
- Do not reach into the cooking compartment until the steam has cleared.
- Do not reach into steamer or handle hot items without wearing heatproof gloves. Wet or damp gloves conduct heat, and may cause burns when touching hot items.
- Do not use anything but your hands to operate the controls of the steamer.
- Do not block the vents on the side or rear of the unit or obstruct the flow ventilation air to the steamer. Do not store articles on top of the unit.
- Do not ever tilt the unit if the main external power to the unit is on.

The steamer requires a minimum of service if properly operated and maintained by trained personnel. The following steps will help keep the steamer in a safe, efficient operating condition.

1. Do not store or leave combustible materials near the steamer. Keep the area around and under the steamer free of combustible materials.
2. Train all personnel who will use the steamer. Make sure personnel know how to operate the steamer, clean the interior and exterior, drain the unit, and descale the steam generator.
3. Operating personnel must be able to recognize problems, and report them so that corrective actions can be taken by trained personnel as outlined in the troubleshooting charts found in Chapter 3 of this manual.

4. Conduct regular steamer inspections. Check for door seal and drain valve leaks, clogged drain, dirty water probe, and steamer control malfunctions.
5. Follow the instructions for steamer maintenance found in this manual.
6. Before each use of the steamer, inspect the drain valve for blockage. Inspect the door gasket assembly, and slide racks for proper installation and cleanliness.
7. Allow only Cleveland Range authorized service representatives to service the steamer.
8. Use only factory authorized repair parts.
9. Maintain written records of steamer maintenance and service. Each record should include at least:
 - The date of the service or maintenance.
 - A description of the service, maintenance or repair performed. Include part numbers if applicable.
 - Copies of purchase order(s) and invoice(s) for repair parts and service.
 - The name and signature of the person performing the maintenance or service.

B. PRODUCT INFORMATION

Cleveland Range, Inc. assigns two product identification numbers to each steamer: a model number and a serial number. The model number identifies the product characteristics. The serial number identifies the individual unit. The Model No. and Serial No. are also located on the control panel as well as the product information plate for your convenience in accessing this information.

1. Model Number

This manual covers the SteamCub Model No. 1SCE Steam Cooker and Holding Cabinet. Each character of this model number identifies a characteristic of the steamer. The SteamCub Model No. 1SCE has 1 compartment, is a **SteamCub**, an **Electric Model**. This manual covers all standard features and options available on SteamCub electric steamers.

Other than selection of options, there are presently no significant design, parts, or operating differences among steamers with this model number. Figure 1-2 illustrates a SteamCub and identifies the major external features.

2. Serial Number

During manufacture, SteamCub Steamers are assigned individual serial numbers. Whenever any inquiry is made with Cleveland Range regarding a steamer the serial number should be referenced.

3. Product Information Plate

The Product Information Plate on the rear of the unit lists the model and serial number as well as the power and wiring requirements of the steamer. Refer to Figure 1-2 for the location of the plate. Figure 1-1 illustrates a typical SteamCub Product Information Plate.

CLEVELAND RANGE, INC. CLEVELAND, OHIO							
Model No. 1SCE			Serial No. WC 57077-99D-01				
VOLTS	PH	WIRES	HZ	WATTS	AMPS	SUPPLY A.W.G.	
240	3	3	60	9400	22.6	8	



CAUTION: FOR SUPPLY CONNECTION USE ONLY COPPER WIRE
 SUITABLE FOR AT LEAST 75 °C
 ATTENTION: EMPLOYER DES FILS D'ALIMENTATION ADEQUATS
 POUR 75 °C
 COMMERCIAL COOKING APPLIANCE 107702 A

Figure 1-1 SteamCub Product Information Plate

4. "SteamCub" Model No. 1SCE Product View

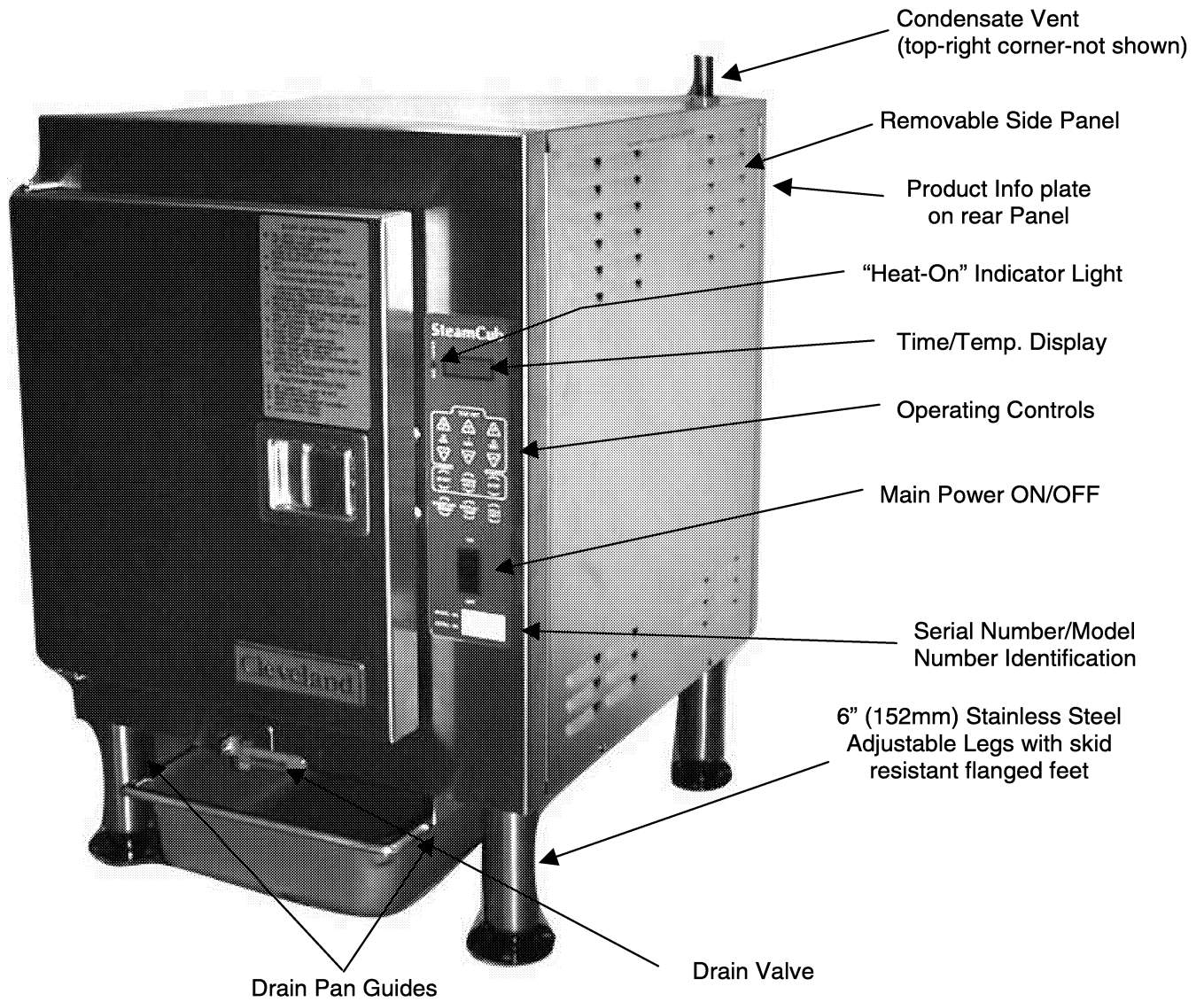

Figure 1-2 SteamCub Steam Cooker And Holding Cabinet

CHAPTER 2 – OPERATION

A. GENERAL OPERATION

1. Main Power Switch

Usually the steamers main power switch is left ON. If the main power switch was left in the OFF position, turn it ON as follows.

- a. Turn the ON/OFF switch to the OFF position.
- b. The control settings are not important in this procedure. The control panel circuits are not powered while the ON/OFF switch is set to OFF.
- c. Refer to the main power switch in Figure 2-1, and turn on electric power to the steamer.

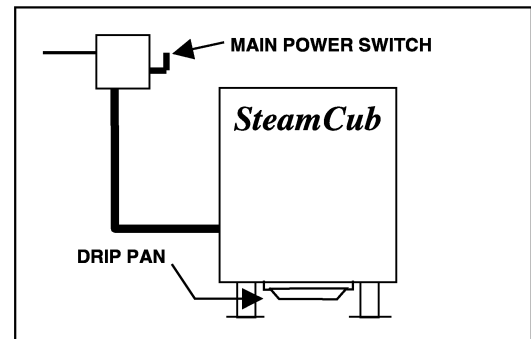

Figure 2-1 Main Power Switch

2. Door Interlock Switch

The steamer compartment of the SteamCub is equipped with an automatic steam cutoff switch, which turns OFF the production of steam whenever the door to the compartment is opened. **NOTE:** That even though the continued production of steam ends as soon as the door is opened, it may take up to a minute for residual heat in the system to stop producing steam in the cooking compartment. To avoid possible injury always wait until this residual steam has cleared before reaching into the cooking compartment. **Remember the SteamCub is always heating in either the hold mode or the steam mode, whenever the main power switch is in the ON position and the steamer door is closed.**

3. Inspecting The Cooking Compartment – Manual Water Fill

- a. Before turning ON the power switch to the SteamCub, the entire inside of the steamer must be thoroughly cleaned.
- b. All food debris should be wiped clean and the drain opening and the water level screw shall be inspected and cleaned of any residue or debris (See Figure 2-2).
- c. After completing the inspection and cleaning of the steamer interior, close the manual drain and fill the bottom of the cooking compartment with 1½ gallons of fresh potable cold water.
- d. The steamer should be filled with fresh water every day if not the start of every shift.
- e. Before every steaming operation, inspect the cooking compartment and remove any food debris from the racks and walls of the compartment. Check the water and add water if low or empty and refill with fresh water if water has become soiled or discolored. **DO NOT USE DISTILLED WATER.**

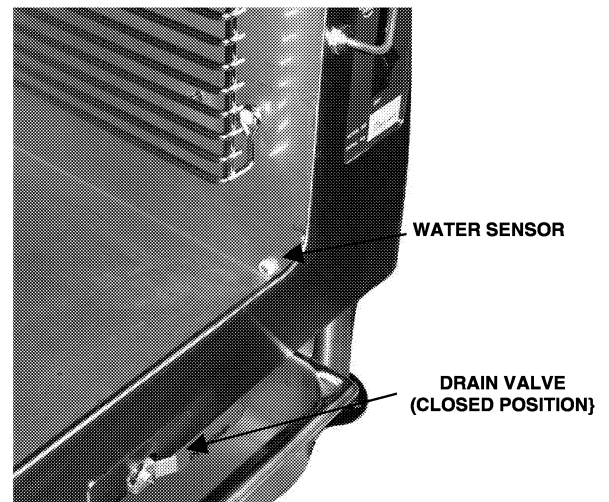

Figure 2-2 Compartment Water Fill

NOTE: The water should be filled to about ½” below the front lip of the steamer at the start of cooking.

4. Power On (Automatic Preheat)

When the SteamCub is turned on, it automatically begins to heat the water supply to cooking temperature whenever the main power switch is on and the steamer door is closed. When ready to start using the steamer, begin either of the Timed or Manual Cooking Procedures or the Holding procedure.

- a. Press the ON (top) end of the ON/OFF switch to the ON position to energize the steamer control panel. The red indicator on the switch lights, the red “heater ON” indicator on control panel lights, and the steamer begins the preheat cycle. (see Figure 2-3)
- b. When the generator reaches cooking temperature, the heating elements begin to cycle maintaining a temperature in the cooking compartment of approximately 205°F. The red “heater ON” indicator light will cycle ON and OFF indicating when the heating elements are energized.

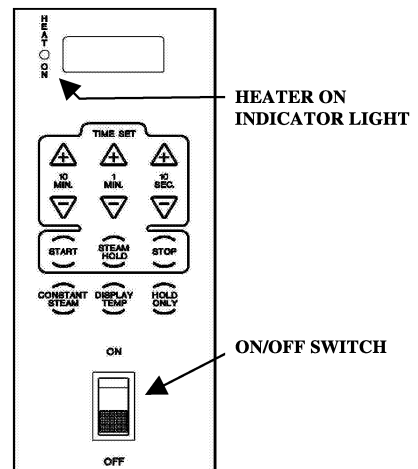

Figure 2-3 ON/OFF Controls and Indicators

5. Preheating The Steamer

Preheating the steamer can help insure that the best productivity and consistent cooking is obtained. To preheat the SteamCub, simply turn the unit on approximately 15 minutes before you are ready to cook. The unit will automatically go into the preheat mode and prepare the unit for cooking.

- **BEFORE PREHEATING**, inspect and clean the compartment. After preheating, the compartment will be too hot to inspect and clean safely.

6. Low Water Alarm

IF an attempt is made to run the steamer without water, or if the water level drops below the sensor level, the Electronic Controller display will read “add H2O” a loud continuous beep will start and the heating elements will be turned OFF. To turn off the alarm and continue cooking additional water will have to be added before cooking can be continued.

B. CONTROL PANEL OPERATION

The SteamCub is a continuously operating appliance and is constantly standing by and ready to cook whenever the ON/OFF switch of the control panel is in the ON position. The SteamCub is equipped with an electronic control panel, which allows you to simply select the mode of cooking at the touch of a button.

For safe, efficient operation of the steamer, the operator must, at a minimum, comply with all cautions, warnings and instructions in the detailed operating procedures and be familiar with the control panel shown in Figure 2-4. The operator should be familiar with all the operating features explained in this chapter before attempting to operate the steamer.

Cooking Modes – Constant Steam Cooking, Holding and Timed Cooking

The steamer has three operating modes: continuous steam, holding and timed cook and hold. These different modes are selected by pressing the appropriate button(s) on the controller.

1. Constant Steam Mode

The Constant Steam mode provides for continuous steam cooking. The SteamCub automatically goes into this mode when the unit is turned ON. In this mode the controller automatically heats the compartment to the cooking temperature (approximately 205°F), and maintains this temperature by cycling the heating elements. The Digital display will show either “Cont” if the Cooking compartment is at the operating temperature or “flashing Cool” if the compartment is not yet to temperature. See the Operating and Cooking Procedure – Continuous Steam Mode in Chapter 2, Part C Section 2 for more information.

▲ WARNING

Press switches with fingertips only. Do not use kitchen utensils or anything sharp to operate the switches.

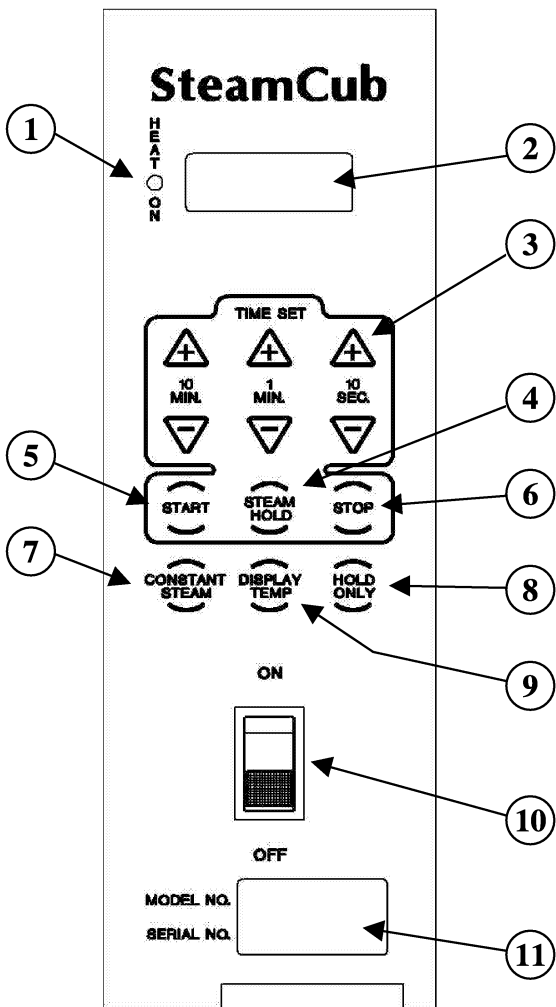

- (1) **Heater on Indicator Light** – When the Red indicator light is on the heating elements are ON.
- (2) **Time/Temperature/Mode Display and Low Water Indicator** – This four-digit display may read any of the following:
 - “00:00” to “99:50” when at temperature in the timed mode or when the timer is being set.
 - “PAUSE” When in timed mode but below cooking temperature or door is open and the timer has been started.
 - “Cool” When in the Steam and Hold mode below temperature and the timer not started.
 - “HoLd” When in the holding mode.
 - “Cont” when in continuous steam mode and at temperature.
 - It flashes “Cool” when in continuous steam mode and not at temperature.
 - “The current Temperature” when the (DISPLAY TEMP) button is pressed.
 - “Addh2o” when the water level is below the water sensor.
- (3) **Time Set Control keys** – When in the Cook and Hold mode these Keys can be used to adjust the time controls in 10 minute, 1 minute and 10 second increments.
- (4) **(Steam/Hold) key** – This key activates the Steam and Hold mode, and allows the timer to be reset.
- (5) **(START) Key** – This key starts the timed cook function.
- (6) **(STOP) Key** – Holding this key for 5 seconds changes the mode to the Steam and Hold mode and resets the timer to its last set time.
- (7) **(CONSTANT STEAM) Key** – This key resets the control to Constant Steam Mode.
- (8) **(HOLD ONLY) Key** – This key sets the control to holding temperature mode.
- (9) **(DISPLAY TEMP) Key** – When this key is depressed the digital display will briefly show the current temperature in the cooking compartment in °F.
- (10) **ON/OFF Switch** – The ON/OFF switch controls the electric power to the unit.
 - Pressing the ON (top) end of the switch energizes the steamer control panel. A red indicator on the switch lights, and the steamer begins to heat-up.
 - Pressing the OFF (bottom) end of the switch turns the steamer control panel OFF and the red indicator goes out.

(11) **Serial Number/Model Number Display**

Figure 2-4 Key Pad Control Panel

2. Hold Only Mode.

The Holding mode is similar the continuous mode except that the controller warms and maintains the cooking compartment at a “Holding Temperature” (160°F minimum), to keep food at serving temperature without a loss in food quality or taste. The steamer automatically enters this mode at the conclusion of a timed cooking program or it can be started manually by pressing the “HOLD ONLY” function key on the controller. The Digital display will show “**HoLd**” whenever the steamer is in this mode whether at the end of timed cooking program or if the unit is set to “continuous hold. See the Operating and cooking procedure – Holding Mode in Chapter 2, Part C Section 3 for more information.

3. Timed Cook and Hold Mode and Use of the Timer

a. General operation

- The electronic timer times and stops steam cooking operation, and monitors cooking time and compartment temperature for accurate, efficient, uniform steam cooking.
- Until a timed operation is started the timed mode works identically to the continuous cooking mode; as soon as this mode is entered the steamer will heat the cooking compartment to the cooking temperature, and continue to maintain the cooking temperature by cycling the elements. The display will read “**Cool**”, until the cooking temperature is reached at which time the timer setting will be displayed.
- The difference is that once the timed cook is started the timer of the SteamCub uses a temperature compensation circuit. When operating, the timer **ONLY COUNTS DOWN WHILE THE COOKING COMPARTMENT IS AT COOKING TEMPERATURE**. This provides totally automatic control of the steaming operation and assures uniform cooking as the timer automatically compensates for food product defrosting and/or compartment heat up time. Whenever the steamer is not at cooking temperature or the door is opened, the timer pauses and the display shows “**PAUSE**”, once temperature is reached a digital display of the remaining time is displayed. When the timer counts down to zero an alarm will sound, to indicate that cooking is complete and the steamer will automatically go into the “hold” mode and the display will read “**HoLd**”.
- See the Operating and cooking procedure – Cook and Hold Mode in Chapter 2, Part C Section 1 for more information.

b. Setting and Using the Timer in Steam and Hold Mode

(1) Setting the Timer

To set the cooking time, first press the (STEAM/HOLD) button. The timer can be set only when the steamer is in the Steam and Hold Mold. The cooking time display contains four digits. The left two digits are minutes, and the right two digits are seconds. The display 12:30 is set for 12 minutes and 30 seconds. To set the cooking time:

- (a) Change the required cooking time to minutes and seconds.
- (b) Press the (+) and (–) keys for 10’s of minutes, minutes, and 10’s of seconds to adjust the time up or down to the desired setting.
- (c) The time can be changed before starting to cook or during a cooking cycle if it is determined that more or less time will be required.

NOTE: When the SteamCub is in the “Steam and Hold” mode it operates exactly as it would in the “Constant Steam” mode until a timed cook program is started.

(2) Starting the Timer

Press the START key to start the timer. When the START key is pressed, the timer begins to count down time whenever the cooking compartment is at temperature.

- (a) The timer display reads “**PAUSE**” until the cooking compartment reaches proper cooking temperature, or when the door is opened.

- (b) When the cooking compartment reaches proper cooking temperature, the timer display shows the count down.

NOTE: A timer setting of 10 minutes may in fact take 11 or 12 minutes for the timer to count down and the alarm to sound. This is normal. Heating the compartment and food to cooking temperature uses the additional time.

(3) Stopping the Timer

If for some reason, the timing cycle needs to be discontinued or you wish to return to the timed cook mode from the hold mode after a programmed cook has ended press the STOP key and hold it for 5 seconds.

(a) The timer will then reset to its original time.

(b) The STOP key can be used at any time in any mode to return the steamer to the Steam and Hold mode and reset the timer.

NOTE: It is important to remember that that the STOP button does **NOT** stop the cooking, it only resets the timer and any food in the steamer will continue to cook.

(4) When Timed Cook is Done

When the timer counts down to zero, the alarm sounds for 5 seconds, and the steamer automatically goes into the Hold Mode.

- Press the STOP key when you are ready to return to the cooking mode. The cooking time display returns to the last time set and the steamer will return to the cooking temperature if it was in the hold mode. Either run this same setting again or reset the timer to a new time.

4. Display Temperature Function

The temperature in the SteamCub can be checked at any time the main power switch is in the ON position. Simply press the “DISPLAY TEMP” key and the current temperature (°F) in the steam compartment will be displayed for about 5 seconds. This feature works in all operating modes.

C. COOKING WITH THE STEAMCUB

IMPORTANT
The SteamCub is a continuously operating appliance and is constantly standing by and ready to cook whenever the ON/OFF switch of the control panel is in the ON position.

1. Operating And Cooking Procedure – Steam And Hold Mode

In the Steam and Hold mode, the timer monitors the actual cooking time and automatically starts holding mode when the cooking time has completed.

- Refer to “Inspecting the Cooking Compartment – Manual Water Fill” in Chapter 2, Part A Section 3. Inspect and clean the insides of the cooking compartment as required, and fill the unit with water.
- If necessary, refer to “Preheating the Steamer”, in Chapter 2, Part A, Section 5, and preheat the cooking compartment.
- Put the ON/OFF switch in the ON (top) position.
- Press the Steam and Hold key, to put the steamer into the timed steaming mode.
- Set the required cooking time by adjusting the time up or down using the (+) and (–) keys.

- f. Slide the pans of food into the slide racks inside the steamer. Do not place pans or anything else on the bottom of the compartment.

 **CAUTION**

Some foods drip juices. Use a solid catch pan under perforated pans when steaming food that will drip juices. Failure to use a catch pan can cause a clogged drain valve and increase the cleaning maintenance time of the steamer.

- For best cooking results, use shallow, 2-1/2 inch deep, perforated pans without covers. These give the best heat transfer and shortest cooking time.
- g. As soon as the food is loaded close the steamer door, and hit the start button to begin the timed cook.
- h. When the timer reaches zero, an alarm will sound for 5 seconds, and the steamer will automatically go into the “Hold Mode”. The cooking cycle is complete, and the SteamCub will automatically adjust the cooking compartment to the holding temperature of 160°F to keep the food warm and fresh and the display will read “HoLd”.

 **WARNING**

SEVERE BURNS may result from exposure to steam.

Do not open the steamer door before steam flow stops. Stand back when opening the compartment door. Open the door slightly to allow steam to vent before looking or reaching into cooking compartment. Do not reach into cooking compartment until the steam has cleared.

Do not reach into steamer or handle hot items without wearing heatproof gloves. Wet or damp gloves conduct heat, and may cause burns when touching hot items.

- i. Carefully open the cooking compartment door, and remove the pans from the slide racks.
- Press the STOP key and hold it for 5 seconds to return the steamer to the timed cooking mode.
 - If the steamer will be used again in a few minutes shut the door to maintain the cooking compartment temperature.
 - If the steamer is not being used again during this shift, perform the Power OFF and Shut Down and Cleaning Procedures.

2. Operating And Cooking Procedure – Constant Steam Mode

The Constant Steam mode allows the operator to personally control the cooking functions. The operator monitors the steaming operations, and determines the cooking time including time for steam generator, compartment and food heat-up time. Use the Constant Steam cooking mode for:

- A continuous supply of steam.
- Cooking times longer than the timer can measure.
- Maintaining the compartment temperature between cooking batches.

a. Control Operation in Constant Steam Mode

When cooking in the Constant Steam Mode, there is no need to do any additional control actions unless it is required to change to a different operating mode. In fact the only control functions that will operate when in this mode are as follows:

- (STEAM HOLD) Key – Depressing this key will change the steamer to the Steam and Hold Mode.
- (HOLD) Key – Depressing this key will change the steamer to the holding mode.
- (STOP) Key – Depressing this key and holding it for 5 seconds will change the steamer to the Steam and Hold Mode.
- DISPLAY TEMP) – Depressing this key will display the current cooking compartment temperature.

b. Constant Steam Cooking Procedure

Follow this procedure when cooking with the steamer in Constant Steam mode.

- (1) Refer to INSPECT THE COOKING COMPARTMENT in Section 2, Part E. Inspect and clean the drain and cooking compartment as required.
- (2) In Constant Steam Mode, the operator can bring the compartment to cooking temperature by either preheating or increasing the cooking time. If the operator chooses to preheat the cooking compartment manually, refer to Section 2, Part F, PREHEATING THE STEAMER.
- (3) Put the ON/OFF switch in the ON (top) position.
- (4) Press the Constant Steam key, to put the steamer into the Continuous Steam mode.
- (5) Slide the pans of food into the slide racks inside the steamer. Do not place pans or anything else on the bottom of the compartment.

⚠ CAUTION

Some foods drip juices. Use a solid catch pan under perforated pans when steaming food that will drip juices. Failure to use a catch pan can cause a clogged drain valve and increase the cleaning maintenance time of the steamer.

- For best cooking results, use shallow, 2-1/2 inch deep, perforated pans without covers. These give the best heat transfer and shortest cooking time.
- (6) Close the steamer door. The Steamer will begin to cook as soon as the door is closed.

⚠ WARNING

SEVERE BURNS may result from exposure to steam.

Do not open the steamer door before steam flow stops. Stand back when opening the compartment door. Open the door slightly to allow steam to vent before looking or reaching into cooking compartment. Do not reach into cooking compartment until the steam has cleared.

Do not reach into steamer or handle hot items without wearing heatproof gloves. Wet or damp gloves conduct heat, and may cause burns when touching hot items.

- (7) When cooking is complete carefully open the cooking compartment door, and remove the pans from the slide racks.
- If the food is not yet needed leave the food in the steamer and hit the Hold Only key to change the compartment temperature to a holding temperature of 160°F to keep the food warm until it needs to be served
 - If the steamer will be used again in a few minutes shut the door to maintain the cooking compartment temperature.
 - If the steamer is not being used again during this shift, perform the Power OFF and Shut Down and Cleaning Procedures.

3. Operating Procedure – Hold Only Mode

The Hold Only mode allows the operator to keep food warm, fresh and safe for long periods of time without reducing its quality. When in the Holding mode the SteamCub automatically maintains the inside of the cooking compartment at a minimum temperature of 160°F to keep food safe. Use the Holding mode for:

- Keeping foods warm after it has been cooked in the Continuous Steam Mode.
- Keeping foods warm and fresh, which have been previously cooked in other kitchen equipment until it needs to be served.
- Maintaining a warm compartment temperature during longer unused periods.
- The SteamCub automatically switches to this mode at the end of a timed cooking program.

a. Control Operation in Hold Only Mode

When in the Hold Only Mode, there is no need to do any additional control actions unless it is required to change to a different operating mode. In fact the only control functions that will operate when in this mode are as follows:

- (STEAM HOLD) Key – Depressing this key will change the steamer to the Steam and Hold Mode.
- (CONSTANT STEAM) Key – Depressing this key will change the steamer to the Continuous Cooking Mode.
- (STOP) Key – Depressing this key and holding it for 5 seconds will change the steamer to the Steam and Hold Mode.
- DISPLAY TEMP) – Depressing this key will display the current cooking compartment temperature.

b. Using the Hold Only Mode

To use the SteamCub as a holding cabinet, use the following procedure:

- (1) Refer to Inspecting the Cooking Compartment – Manual Water Fill in Chapter 2, Part A, Section 3. Inspect and clean the drain and cooking compartment as required.
- (2) Put the ON/OFF switch in the ON (top) position.
- (3) Press the Hold Only key, to put the steamer into the Holding mode.
- (4) Slide the pans of food into the slide racks inside the steamer. Do not place pans or anything else on the bottom of the compartment.

CAUTION

Some foods drip juices. Use a solid catch pan under perforated pans when steaming food that will drip juices. Failure to use a catch pan can cause a clogged drain valve and increase the cleaning maintenance time of the steamer.

- (5) Close the steamer door. The Steamer will begin to heat the compartment up to the holding temperature as soon as the door is closed.
- Although food will remain safe in the holding mode for long periods of time, holding foods too long can reduce its quality.
 - The maximum recommended time food can be held without a reduction in food quality is about two hours, but this may vary depending on the type of food.

 WARNING
SEVERE BURNS may result from exposure to steam. Do not open the steamer door before steam flow stops. Stand back when opening the compartment door. Open the door slightly to allow steam to vent before looking or reaching into cooking compartment. Do not reach into cooking compartment until the steam has cleared. Do not reach into steamer or handle hot items without wearing heatproof gloves. Wet or damp gloves conduct heat, and may cause burns when touching hot items.

- (6) When the food is needed for serving, carefully open the cooking compartment door, and remove the pans from the slide racks.
- If the steamer will be used again in a few minutes shut the door to maintain the cooking compartment temperature.
 - If the steamer is not being used again during this shift, perform the Power OFF and Shut Down and Cleaning Procedures.

4. Using the SteamCub to Rethermalize Food

The SteamCub may also be used to reheat/rethermalize previously cooked and/or refrigerated foods to serving temperature in minutes. To use the SteamCub to rethermalize food, follow the instructions below:

- Use the SteamCub in the Constant Steam Mode as outlined in Chapter 2, Part C, Section 2, and cook the food to a safe serving temperature, 160-170 °F for most foods.
- Depending on initial food temperature and density, most foods should be rethermalized to a serving temperature in 10 to 40 minutes.
- Always check internal temperature of food with a thermometer to determine when it has been rethermalized to a safe temperature (160° to 170°F).

NOTE: Cooking times may be longer for some foods and/or larger loads, especially when using 6 kW SteamCub models.

D. SHUTDOWN AND CLEANING PROCEDURE

This procedure should be performed at the end of each day or shift.

 WARNING
Do not use a hose or water jet to clean this appliance.

⚠ CAUTION

When cleaning do not pick up or tilt the SteamCub. If it is absolutely necessary to move a SteamCub for cleaning, turn OFF power at the main external power supply switch.

Catastrophic damage can result from shifting the SteamCub more than 10° out of level while power is turned on at the main external power supply switch.

The steamer MUST BE LEVEL BOTH FRONT TO BACK AND SIDE TO SIDE in all mounting arrangements.

1. Press the OFF (bottom) end of the ON/OFF Switch to turn the power off and deenergize all controls.
2. Open the steamer door and allow steamer to cool.
3. Make sure an empty drain pan (2½" min depth) is installed in the drain racks and drain the steamer by turning the drain handle (up) to the drain position.
 - The drain pan should have the front edge pulled out just enough, so that the drain will empty fully into the pan. Having the pan pushed back too far into the rack or pulled out too far from the rack can cause spillage or tipping of the drain pan respectively. (See Figure 2-5)

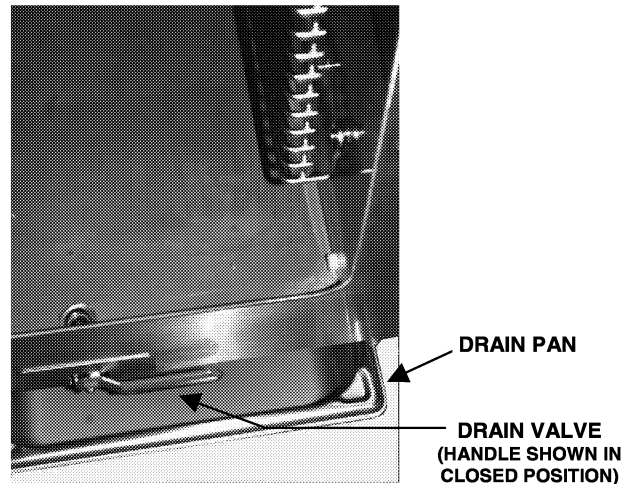

Figure 2-5 Draining the Steamer

⚠ WARNING

Inside of steamer stays hot for a long time. Be careful when cleaning inside steamer compartment.

4. Remove the slide racks. Wash and rinse racks separately or clean them in a dishwasher according to health requirements.
5. Remove any spilled food from inside compartment and clear any residue from the drain valve. Clean the interior of the compartment thoroughly. Use a soft bristle brush to clean the water sensor, temperature probe and to remove stubborn food particles. Do not use abrasive cleaning compounds or steel wool. Rinse inside of steamer compartment and drain valve with clean water.

6. Clean the door assembly.
 - Remove the door gasket assembly (see Figure 2-6).
 - Note the keyhole slots on the door and the retaining pins on the gasket assembly. Grasp the gasket assembly at the sides and lift up and towards you to remove the assembly.
 - Clean all surfaces of the gasket assembly, as well as the inside of the door, by wiping with a damp cloth.
 - Rotate the liner assembly 180° and replace the gasket assembly by sliding the retaining pins into the keyhole slots. Either long edge of the gasket assembly can be positioned at the top. Periodic rotating of the door assembly will increase the door gasket life.

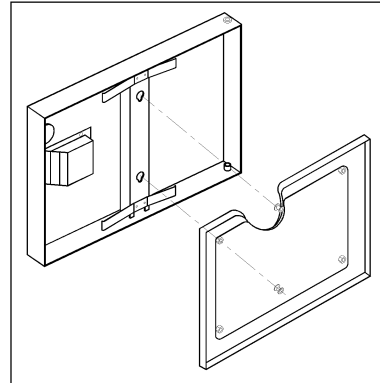

Figure 2-6 Door Gasket Assembly

7. Replace the cleaned slide racks.
8. Wipe the exterior with a damp cloth only. **NEVER HOSE DOWN THE STEAMER.** Electrical components inside the unit will not function correctly if wet or damp.
9. After the drain pan has cooled, carefully remove the pan from the slide racks and dump it into a drain or sink. Clean the pan thoroughly and return it to the slide rack.
10. After cleaning, leave the steamer door open until the next steamer operation. This prevents compartment odor buildup and increases gasket life.

CHAPTER 3. PREVENTATIVE MAINTENANCE AND TROUBLESHOOTING

A. MAINTENANCE

Maintenance on the steamer must be performed on a regular basis to keep the unit running properly and efficiently. By following the simple maintenance instructions in this chapter and cleaning the equipment regularly as outlined in Chapter 2, Part C, problems with the steamer will be kept to a minimum. As with any preventative maintenance schedule, the frequency of steamer maintenance may need to be increased, depending on equipment usage and water quality. If problems do occur, refer to the Troubleshooting Guide in this chapter. For more information on product and services, contact your sales representative.

1. Maintenance Records

Make a file solely for maintenance and repair records. Keep a written record of daily, weekly, monthly, and yearly maintenance. These records will protect warranty coverage, help personnel to know when to perform various maintenance procedures, help keep the SteamCub cooking properly and assist service personnel.

Daily Maintenance

a. Checking and Changing the Water

When using the SteamCub frequently check the water, especially if cooking with perforated pans. Replace the water as outlined below whenever the water becomes cloudy or heavily contaminated with food particles. At the very least **CHANGE THE WATER IN THE STEAMCUB AT LEAST EVERY DAY IN ORDER TO MAINTAIN FOOD QUALITY AND KEEP THE STEAMER SANITARY.**

Note: It may be necessary to change the water several times a shift, especially if cooking strong flavored foods or with perforated pans.

- (1) Press the OFF (bottom) end of the ON/OFF Switch to turn the power off and deenergize all controls.
- (2) Open the steamer door.
- (3) Make sure an empty drain pan (2½" min depth) is installed in the drain racks and drain the steamer by turning the drain handle (up) to the drain position.
 - The drain pan should have the front edge pulled out just enough, so that the drain will empty fully into the pan. Having the pan pushed back too far into the rack or pulled out too far from the rack can cause spillage or tipping of the drain pan respectively. (See Figure 3-1)

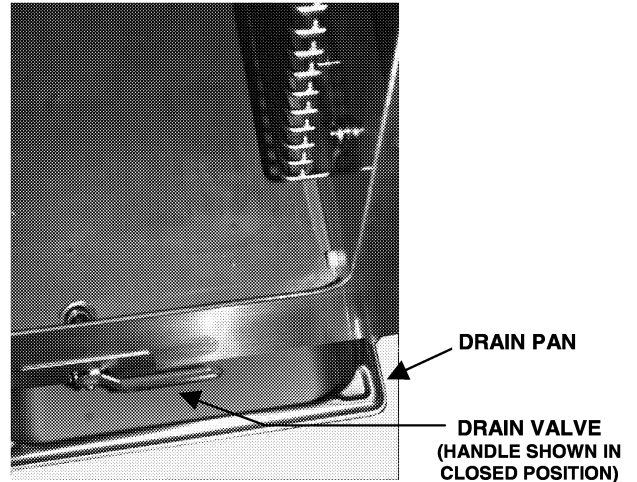

Figure 3-1 Draining the Steamer

▲ WARNING

Inside of steamer stays hot for a long time. Be careful when cleaning inside steamer compartment.

- (4) Remove any spilled food from inside compartment and rinse any residue from the drain valve.
- (5) Turn the drain handle clockwise to the closed position (down) and refill the steamer with 1½ gallons of fresh potable water.
- (6) Press the ON (top) end of the ON/OFF Switch to turn the power ON and reenergize the controls. The steamer is now ready to start cooking again.
- (7) After the drain pan has cooled, carefully remove the pan from the slide racks and dump it into a drain or sink. Clean the pan thoroughly and return it to the slide rack.

b. Cleaning the Steamer

Clean interior and exterior of the steamer according to the shutdown instructions in Chapter 2, Part D at least once per day if not at the end of each shift.

B. OPERATORS TROUBLESHOOTING GUIDE

The Troubleshooting guide includes a list of symptoms that may be encountered during routine operation and maintenance. The first column on the left (PROBLEM) describes these symptoms. The second column lists the possible causes for the problem in column one. The third column lists possible remedies for the problems and causes in columns one and two. The causes and remedies are listed in the order they should be checked, with the least costly and easiest to repair listed first. The third column also refers to notes that are grouped at the end of the troubleshooting guide. Refer to these notes when instructed to do so.

Table 6-1 Trouble Shooting Guide

PROBLEM	POSSIBLE CAUSE	REMEDY/REFERENCE
Power indicator light does not turn on when ON/OFF switch is in the ON position.	Power turned off at main power switch.	Turn on power at main power switch.
	Inoperative controls.	See note #1

(Continued on next page)

Table 6-1 Trouble Shooting Guide (Continued)

PROBLEM	POSSIBLE CAUSE	REMEDY/REFERENCE
Control panel POWER indicator light on, heater ON indicator is OFF and steamer is not up to cooking temperature or producing steam.	Door interlock switch not engaged.	Close door completely.
	Unit is in Hold Mode	Change mode to a cooking mode. Hold mode does not heat high enough to produce steam.
	Inoperative controls.	See note #1.
Steam and/or water draining around the compartment door.	Water level filled too high	Drain off excess water in steamer
	Vent clogged or covered.	Clear vent
	Door gasket or door parts worn.	See note #1.
	Steamer not level.	See note #2.
Display reads "Add h2o", but steamer is filled with water.	Sensor is dirty.	Clean water sensor
	Distilled water used to fill steamer.	Water sensor may not work with distilled water. Use non-distilled water or add ¼ teaspoon of salt or an aspirin to the water.
	Inoperative controls.	See note #1.
Compartment bottom dirty with food drippings.	Juices and/or food leaking from pans.	Put a solid pan under perforated pans to catch drippings, or put less food in pan.
Food takes too long to cook.	Pans too close to the bottom of cabinet.	Put pans in racks near top of cabinet.
	Compartment overloaded with too much food.	Put less food into pan. Use fewer pans.
	Suggested cooking times are usually listed for cooking at sea level.	Extend cooking times for altitudes above 2500 feet.
	Unit is in the hold mode.	Set the controller to a cooking mode.
	Voltage too low for unit.	See note #3.
Control panel Power indicator is on, but controller is not lit and buzzer is buzzing continuously.	Hi limit has been tripped.	Turn OFF power for 5 minutes and back ON. If problem repeats itself, see Note #1.
	Inoperative controls.	See Note #1.
Steam coming out of the exhaust.	A small amount of steam may issue from the exhaust, every time the elements are cycled in the cooking mode.	This is normal operation of the steamer NO action is necessary.
	If steam continuously issues from the vent during, without any interruptions, the thermostatic control is not operating properly.	See Note #1.

TROUBLESHOOTING NOTES

1. A qualified service technician must repair problem or do the appropriate maintenance
2. Proper installation of the steamer is the responsibility of the owner or installer. A qualified installer or technician should be contacted to correct the installation
3. Repairs to external wiring should be done by a Licensed Electrician.
4. For more information on products and services, contact your nearest Authorized Sales Representative.

CHAPTER 4. INSTALLATION INSTRUCTIONS

A. GENERAL

This equipment should only be installed by qualified electricians. The installation of this steamer must conform with all the applicable national and local electrical and sanitation codes and installation requirements.

 WARNING
Improper installation, adjustment, alteration, service or maintenance can cause property damage, injury or death. The Installation, Operating and Maintenance instructions should be read thoroughly before installing or servicing this equipment
DO NOT INSTALL a SteamCub steamer suspected of damage.
Install the SteamCraft steamer according to the policies and procedures outlined in this manual.

- In order to properly install this steamer, the following requirements must be considered when selecting a location.
 - a. A suitable electrical supply must be available matching the power requirements found on the rating plate.
 - b. The location must have sufficient space to meet the clearance requirements of the steamer as outlined in Chapter 4, Section B, Part (1), "Locating the Steamer".

B. INSTALLATION OF THE STEAMCUB

After selecting the steamer's operating location the steamer can be positioned, and installed. After Startup and Checkout, the SteamCub steamer will provide years of reliable operation.

 CAUTION
Malfunctions and equipment damage may result from improper mounting.
The steamer MUST BE LEVEL BOTH FRONT TO BACK AND SIDE TO SIDE in all mounting arrangements.
Catastrophic damage can result from shifting the SteamCub more than 10° out of level while power is turned on at the main power supply switch.

1. Locating the Steamer

a. Location and Clearance Requirements of the Steamer

- (1) Observe the following criteria when selecting an operating location for the SteamCraft steamer.
 - Maintain a 3-inch operating clearance at the sides of the unit, and at least a 3-inch clearance at the back.
 - A 12 in clearance is recommended on the right side for servicing the steamer.
 - Approximately 24 inches of clearance is recommended in front of the unit for opening the door and standard pan clearance.

- (2) The steamer is typically installed with four adjustable mounting legs, as shown in the dimension drawing. The steamer must be level both front to back and side to side. Select an operating surface that is level enough to allow leveling the unit without extreme adjustment of the legs or shimming of surface mounts.
- (3) The counter area selected must be capable of supporting an operating weight of approximately 225 pounds to include the weight of water and food.
- (4) Do not block the vents on the side or rear of the unit. Do not store articles on top of the unit.
- (5) If a satisfactory counter location is not available, consider using a Model ES-21301 Equipment Stand. This stand, illustrated in Figure 4-2, is designed to support the SteamCub, and meets all necessary support and safety criteria. See Section B, subsection (1) part c. for installation of the SteamCub with this stand.

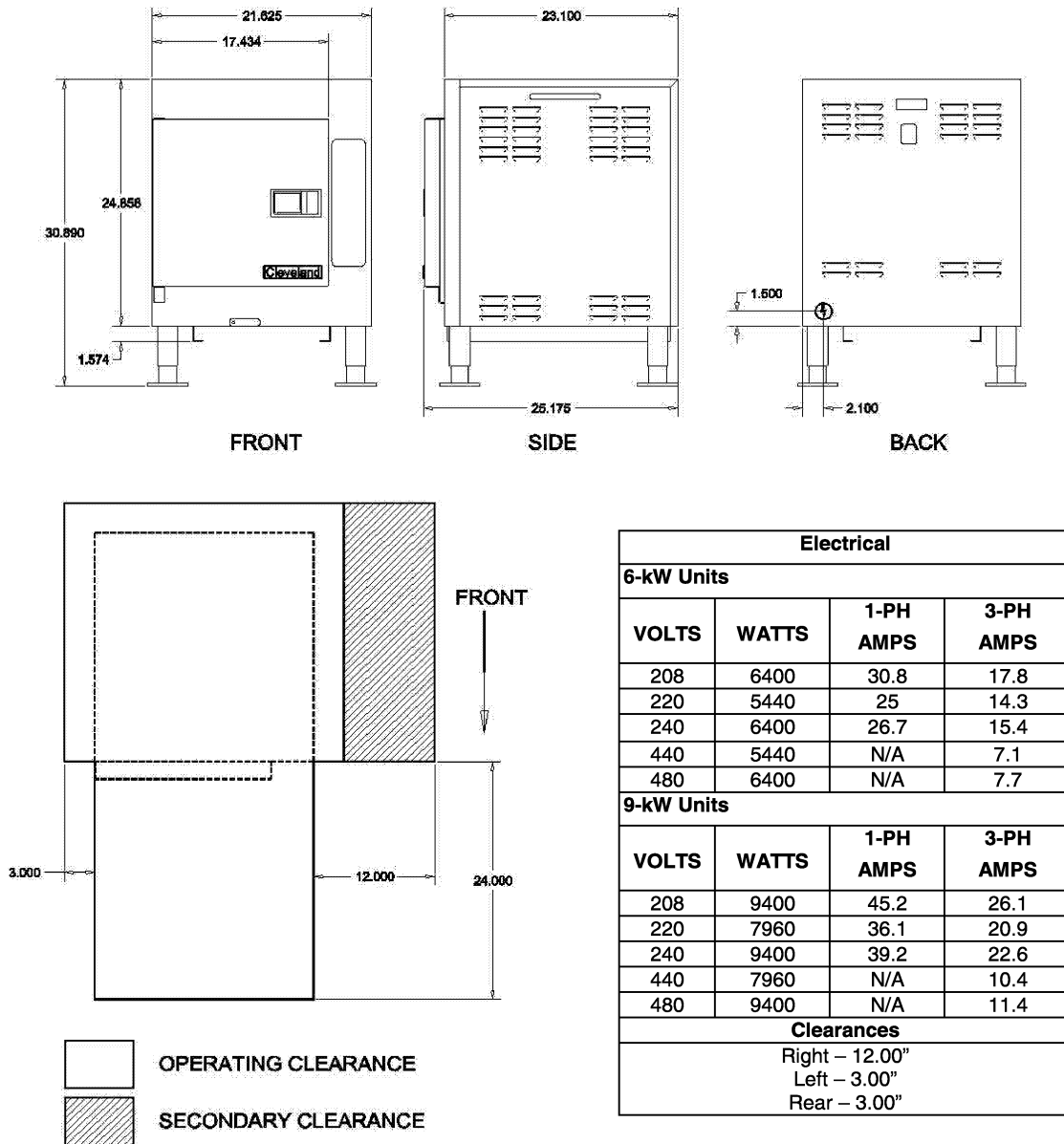



Figure 4-1 SteamCub Dimensions and Clearances

b. **Positioning and Leveling the Steamer**

 WARNING
INJURY AND EQUIPMENT DAMAGE could result from improper lifting. A Model Number 1SCE weighs approximately 185 pounds. Use enough workers with experience lifting heavy equipment to place the steamer on the supporting surface.

Move the steamer into position. Using a level, adjust the adjustable legs until the unit is level.

c. **Installation Using Cleveland Range Stand No. ES-21301.**

- (1) Move the stand into position.
- (2) Remove the four feet from the legs of the steamer, and set the steamer onto the stand. Make sure the bottoms of the legs slide into respective openings on the top of the stand to prevent the steamer from slipping. (See Figure 4-2)
- (3) Using a level, adjust the adjustable legs of the table until the unit is level.
- (4) Once the stand is level, secure the rear two feet to the floor.
- (5) After the stand has been positioned, leveled and secured in place; install the slide racks. The racks are mounted to the stand in the same manner as the slide racks are mounted inside the steamer. Refer to Install "Install Slide Racks", below. Note: the stand is supplied with one (1) set of slide racks, although there are sufficient pins to accommodate two (2) sets.



**Figure 4-2 ES-21301
Equipment Stand**

2. Install Slide Racks and Vent Nipple

- a. Refer to Figure 4-3. Each rack has four loops: two at the top and two at the bottom. Hold the slide rack so the ends of the hanger loops are towards the cavity wall, as shown in the figure.
- b. Slide one rack into the compartment with loops toward one side.
- c. Hook the loops over the top and bottom pins.
- d. Repeat steps a. through c. for the other racks.
- e. Screw the brass nipple provided into the threaded opening found on top, right rear of the unit.

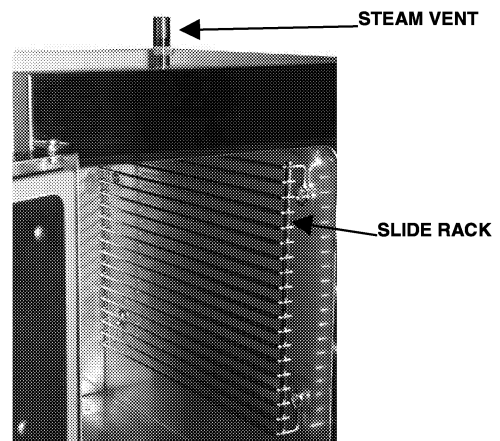

**Figure 4-3 Slide
Rack Installation**

3. Install Electric Power Lines

The electrical supply must match the power requirements specified on the steamers rating plate and be made in accordance with the following requirements:

- a. The steamer must be grounded and have the electrical power lines installed in accordance with local codes and/or the National Electric Code, ANSI/NFPA No. 70-LATEST EDITION (USA) or a the Canadian Electrical Code, CSA Standard C22.1 (Canada).
- b. The wiring diagram is located on the back of the right side panel.
- c. A main disconnect switch should be installed near the unit as shown in Figure 4-3. See Table 4-1 for electrical wire size.
- d. A separate fuse or breaker sized to meet the line amps required by the steamer (see Table 4-1) should be installed either as part of the power switch or in a separate fuse box. Throughout the remainder of this manual the fused disconnect switch is referred to as the main power switch.

Table 4-1 Minimum Wire Requirements

3-Phase Units

WATTS	VOLTS	PHASE	WIRES	CYCLE HERTZ	AMPS	SUPPLY CONNECTION WIRE SIZE (COPPER)
6400	208	3	3	60	17.8	12
5440	220	3	3	60	14.3	14
6400	240	3	3	60	15.4	14
5440	440	3	3	60	7.1	14
6400	480	3	3	60	7.7	14
9400	208	3	3	60	26.1	10
7960	220	3	3	60	20.9	10
9400	240	3	3	60	22.6	10
7960	440	3	3	60	10.4	14
9400	480	3	3	60	11.4	14

HEATER RATED VOLTAGE
208
240
240
480
480
208
240
240
480
480

1-Phase Units

WATTS	VOLTS	PHASE	WIRES	CYCLE HERTZ	AMPS	SUPPLY CONNECTION WIRE SIZE (COPPER)*:
6400	208	1	2	60	30.8	8
5440	220	1	2	60	25	10
6400	240	1	2	60	26.7	10
N/A	440	N/A	N/A	N/A	N/A	N/A
N/A	480	N/A	N/A	N/A	N/A	N/A
9400	208	1	2	60	45.2	6
7960	220	1	2	60	36.1	8
9400	240	1	2	60	39.2	8
N/A	440	N/A	N/A	N/A	N/A	N/A
N/A	480	N/A	N/A	N/A	N/A	N/A

HEATER RATED VOLTAGE
208
240
240
N/A
N/A
208
240
240
N/A
N/A

* For supply connection use only copper wire suitable for at least 75° C (167° F).

- e. There should be a sufficient length of flexible conduit between the steamer and the wall so the unit can be serviced. Mechanically secure the flexible conduit to the electrical access hole (Figure 4-4).

 WARNING
Do not turn on the main power supply to this unit until the installation has been completed and the steamer has been properly grounded.

- f. Refer to the connection diagrams in Figure 4-4, and connect the wires to the terminal block and ground connector accordingly.
- g. The steamer must be electrically grounded by the installer.

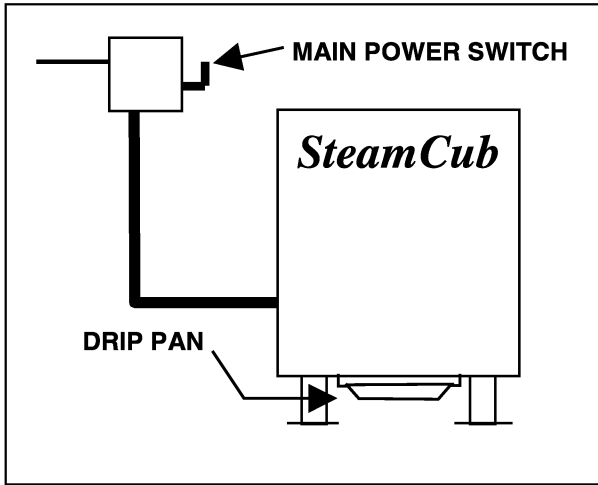

Figure 4-4, Recommended Electrical Layout

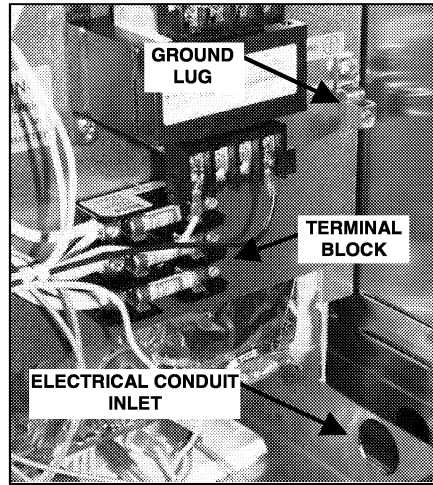

Figure 4-5, Electrical Connections

C. STARTUP AND CHECKOUT

The Startup and Checkout procedure prepares a recently installed or repaired steamer for operation. The procedures check proper installation and electrical connection of the steamer, and verify basic steamer operation.

1. Installation Checkout

Use the Installation Checklist Table 4-2, to check the overall installation.

Table 4-2. Installation Check List

TASK	REFERENCE Page No.	COMPLETED
Preparation		
Verify Electric Power Requirements.	20	_____
Check operating location clearances	17	_____
Verify Field Assembly of Unit	19	_____
Installation		
Verify steamer is level.	19	_____
Check electrical line connection.	20	_____
Perform Startup and checkout.	22	_____

Notes on installation:

2. Operating Test and Final Checkout Procedure

Cleveland Range SteamCub has an electronic control panel, which controls the various modes the steamer can be used for. See Figure 2-4, for a detail of the control appearance.

This procedure will evaluate the function of all the major operating controls of the SteamCub. Read through all steps of this procedure before starting. Complete the Startup Procedure before starting the actual operating tests. **This procedure should be performed only by a service technician or installer.**

a. Startup Procedure

- (1) Check that the drain valve is closed. There should be no water in the steamer.
- (2) Open the steamer door. Check for proper installation of the slide racks, and door gasket assembly. Be sure the drain is not blocked. Shut the steamer door.
- (3) Refer to electrical layout, Figure 4-4, and Table 4-1. Be sure the main power switch is in the off position. Verify installation of the proper size fuses or breakers.
- (4) Set the ON/OFF switch to the OFF position and open the steamer door.
- (5) Remove the right side access cover.

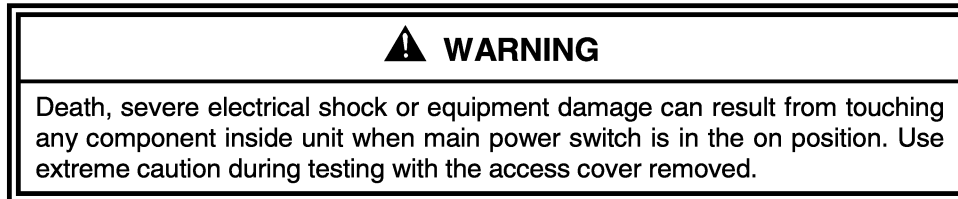

- (6) Check the internal wiring and make sure there re no loose or disconnected wires. Verify that the supply wiring is of adequate size and that the unit is properly grounded. Correct any deficiencies.
- (7) Turn on the main power switch.
- (8) Turn the ON/OFF switch to the ON position.
 - The controls will power up, the display should read “Add h2o”, and an alarm will sound.
 - The heater ON indicator will not be lit.
 - Add 1½ gallons of fresh water to the steamer. The display will change to read “Cool”.
 - **NOTE:** The elements will be de-energized and the display will read “Add h2o” whenever the water level drops below the screw (which acts as a water sensor) located at the lower right front of the steamers interior.

b. Steam and Hold Operation

- (9) Close the steamer door. The door interlock switch will make contact, the heating elements will energize and the heater ON indicator will light.
 - Allow the steamer to continue to run. When the heater reaches the minimum heating temperature (about 10 minutes) the display will change to read the timers current setting.
 - When the display changes, hit the temperature display button. The display should read approximately 185°F, at the time the display changes.
 - Allow the unit to continue heating, until the heater ON indicator goes out. Hit the temperature display button again. The display should read approximately 205°F at the time the indicator goes out. The heater will cycle ON and OFF between compartment temperatures of 195°F and 205°F, respectively.
- (10) Set the steamer timer using the (+) (-) keys and set it for 0 hours, 1 minute, 0 seconds.

(11) Hit the “START” key.

- The timer display will begin to count down, as long as the compartment temperature is at 185°F or greater.
- If the door is opened or the temperature of the compartment is below 185°F, the display will read “PAUSE”.

(12) When the timer finishes counting down:

- An alarm will immediately sound and the display will read “End” for 5 seconds.
- The steamer will automatically go into the “Hold” mode at the conclusion of a timed cooking operation. See Subsection d. “Hold mode” below for details of the Hold function.

(13) Press the “STOP” key.

- The unit will leave the “Hold” mode and the display will return to reading either “Cool” or the last timer setting depending on steamer temperature.
- **NOTE:** Pressing the “STOP” key at any time and in any mode, will reset the timer to its last setting and return the steamer to the “Steam And Hold” operating mode.

c. Constant Steam Mode

(14) Hit the “CONSTANT STEAM” key.

- The display will change to read either a “flashing Cool” if the door is open or temperature is less than 185°F or “Cont” if the temperature is above 185°F.
- Otherwise the “Constant” steam mode operates the same as the cooking portion of the “Steam and Hold” mode except that it continues to cycle in the cooking mode as long as the unit is ON.

d. Hold Mode

(15) Open the steamer door for 1 minute and allow the cooking compartment to cool.

- As soon as the door is opened, the heating elements will be de-energized and the heater indicator light will go out.

(16) Hit the “Hold” Key. The display will change to read “HoLd”.

(17) Close the steamer door.

- The heating elements will be energized and the heater indicator light will come ON.
- Allow the unit to continue heating, until the heater ON indicator goes out. Hit the temperature display button again. The display should read approximately 160°F at the time the indicator goes out. The heater will cycle ON and OFF between compartment temperatures of 155°F and 160°F, respectively as long as the steamer is in “Hold” mode.

(18) Install the side panel and secure it in place with two screws. After completing the Initial Setup and Blowdown Inspection procedure, and the Operating Test procedure; the steamer is ready for service. Refer to Chapters 1 through 3 of this manual for complete operating instructions.

