

Statement of Responsibilities

This document is for use by experienced and trained Qualified Cleveland Range, LLC Authorized Service Representatives who are familiar with both the safety procedures, and equipment they service.

Cleveland Range, LLC assumes no liability for any death, injury, equipment damage, or property damage resulting from use of, improper use of, or failure to use the information contained in this document.

Cleveland Range, LLC has made every effort to provide accurate information in this document, but cannot guarantee that this document does not contain unintentional errors and omissions.

The information in this document may be subject to technical and technological changes, revisions, or updates.

Cleveland Range, LLC assumes no liability or responsibility regarding errata, changes, revisions, or updates.

Qualified Cleveland Range, LLC Authorized Service Representatives are obligated to follow industry standard safety procedures, including, but not limited to, OSHA regulations, and disconnect / lock out / tag out procedures for all utilities including steam, and disconnect / lock out / tag out procedures for gas, electric, and steam powered equipment and / or appliances

All utilities (gas, electric, water and steam) should be turned OFF to the equipment and locked out of operation according to OSHA approved practices during any servicing of Cleveland Range equipment

Qualified Cleveland Range, LLC Authorized Service Representatives are obligated to maintain up-to-date knowledge, skills, materials and equipment.



Pressureless Steamers

SteamCub®

STEAM COOKER &
RETHEMALIZER

MODEL: 1SCEMCS

ITEM NUMBER _____

JOB NAME / NUMBER _____

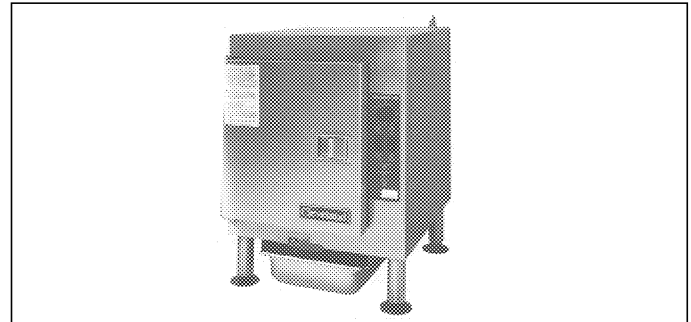
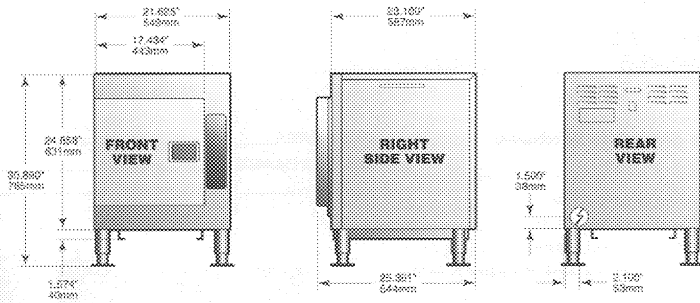

SHORT FORM SPECIFICATION

Shall be a Cleveland SteamCub®, Model 1SCEMCS, one compartment steamer. 60-minute mechanical timer with a low water indicator and alarm. a heat-on indicator light. 9kW power rating. Capacity for five 2 1/2" deep full size steam table pans. 14-gauge stainless steel construction. Two Piece Compartment Door.

WATTS	VOLTS	PHASE	WIRES	CYCLE HERTZ	AMPS	SUPPLY CONNECTION WIRE SIZE (COPPER)	HEATER RATED VOLTAGE
6000	208	3	3	60	17	12	208
5040	220	3	3	60	14	14	240
6000	240	3	3	60	15	14	240
5040	440	3	3	60	7	14	480
6000	480	3	3	60	8	14	480
9000	208	3	3	60	26	10	208
7560	220	3	3	60	20	12	240
9000	240	3	3	60	22	10	240
7560	440	3	3	60	10	14	480
9000	480	3	3	60	11	14	480

WATTS	VOLTS	PHASE	WIRES	CYCLE HERTZ	AMPS	SUPPLY CONNECTION WIRE SIZE (COPPER)*	HEATER RATED VOLTAGE
6000	208	1	2	60	29	8	208
5040	220	1	2	60	23	10	240
6000	240	1	2	60	25	10	240
N/A	440	N/A	N/A	N/A	N/A	N/A	N/A
6000	480	N/A	N/A	N/A	N/A	N/A	N/A
9000	208	1	2	60	44	6	208
7560	220	1	2	60	35	8	240
9000	240	1	2	60	38	8	240
N/A	440	N/A	N/A	N/A	N/A	N/A	N/A
9000	480	N/A	N/A	N/A	N/A	N/A	N/A

Note: Consult local authorities for venting and installation requirements.

* For supply connection use only copper wire suitable for at least 75°C (167°F).

Cleveland Range, LLC

Ph: 1-216-481-4900 Fx: 1-216-481-3782

1333 East 179th St., Cleveland, Ohio, U.S.A. 44110

Visit our Web Site at www.clevelandrange.com

CLEVELAND RANGE 1SCE
SEQUENCE OF OPERATIONS
STEAM CUB
Mechanical Timer

When using these instructions refer to the STEAM CUB wiring schematic.

1. Supply Voltage is sent to the primary of the power transformer.
 - 115 VAC is sent from the secondary of the power transformer to the on/off switch.
2. To turn the unit on, place the 115 VAC switch in the on position.
 - 115 VAC is sent to the H terminal of the water board.
 - 115 VAC is sent to the normally open contacts (R2B) of the R2 relay.
 - 115 VAC is sent to the normally open contacts (R1A) of the R1 relay.
 - 115 VAC is sent to the normally open contacts (R3B) of the R3 relay.
3. After water has been placed in the cooking cavity and the probe is grounded the water board will have 120 VAC at the heat terminal.
 - 115 VAC is sent through the normally closed contacts (R3A) of the R3 relay and the normally closed contacts (R2A) to the door switch.
 - If the water level drops below the probe the water board will remove 115 VAC from the HEAT terminal and send it to the FILL terminal.
 - From the FILL terminal 115 VAC is sent to the coil of the R3 relay.
 - The R3 relay energizes and the normally closed contacts (R3A) open.
 - The normally open contacts (R3B) will close and 115 VAC is sent to the ADD WATER light and buzzer.
4. With the door closed the door switch is closed and 115 VAC is sent to the timed/manual switch.
5. In the timed mode and time on the timer, or in the manual mode, 115 VAC is sent through the thermostat to the coil of the contactor.
 - The contactor closes and supply voltage is sent to the elements and the water is heated to steam.
 - When the cabinet reaches 205 degrees the thermostat opens and 115 VAC is removed from the coil of the contactor and the elements are de-energized.
 - When the unit cools the thermostat closes and the steamer heats again.
6. If one of the high limits (located on the heater blocks) opens a potential difference is placed across the coil of the R1 relay.
 - The R1 contacts will close energizing the R2 relay coil.
 - The normally open R2B contacts will close latching in the R2 coil.
 - The normally closed R2A contacts will open de-energizing the heater contactor.
 - The normally open R2A contacts will close energizing the buzzer.
 - The buzzer will sound until the unit is turned off.
7. To turn the unit of the rocker switch is depressed and the 115 VAC is removed from the heat circuit.

① TIMER SteamCub 6KW / 9KW W/MECHANICAL TIMER (THREE PHASE)

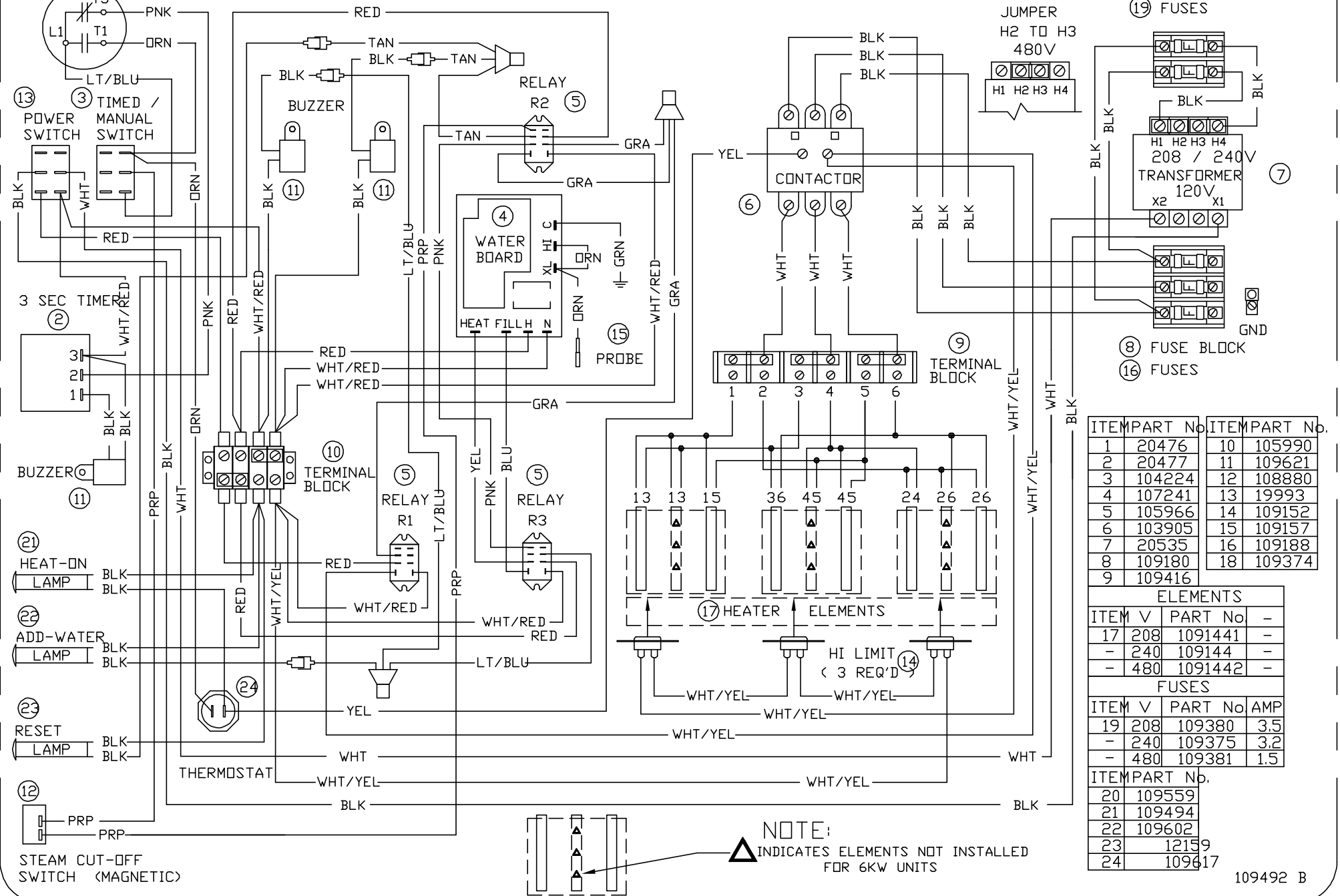

⑬ FUSE BLOCK
⑭ FUSES

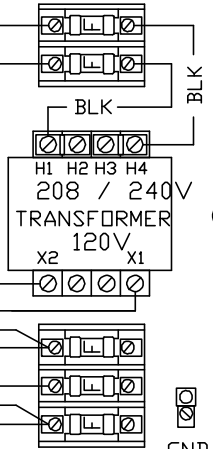
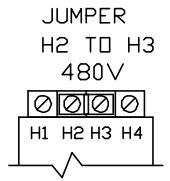

⑧ FUSE BLOCK
⑯ FUSES



ITEM	PART No.	ITEM	PART No.
1	20476	10	105990
2	20477	11	109621
3	104224	12	108880
4	107241	13	19993
5	105966	14	109152
6	103905	15	109157
7	20535	16	109188
8	109180	18	109374
9	109416		

ELEMENTS		
ITEM	V	PART No.
17	208	1091441
-	240	109144
-	480	1091442

FUSES			
ITEM	V	PART No.	AMP
19	208	109380	3.5
-	240	109375	3.2
-	480	109381	1.5

ITEM	PART No.
20	109559
21	109494
22	109602
23	12159
24	109417

NOTE: INDICATES ELEMENTS NOT INSTALLED FOR 6KW UNITS



Pressureless Steamers

SteamCub®

STEAM COOKER,
RETHEMALIZER &
HOLDING CABINET

MODEL: 1SCE

ITEM NUMBER _____

JOB NAME / NUMBER _____

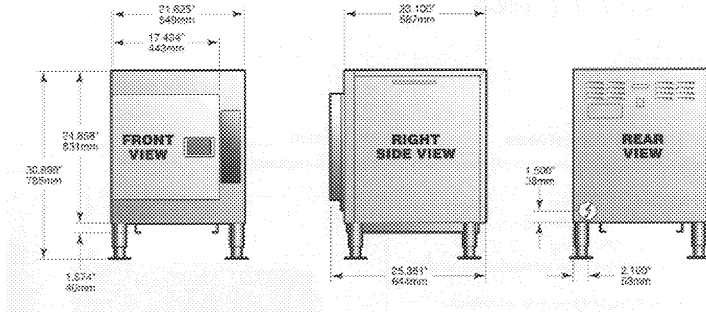

SHORT FORM SPECIFICATION

Shall be a Cleveland SteamCub®, one compartment, Counter top steamer, rethermalizer and holding cabinet, Model 1SCE standard electrical rating 9 kW, optional 6 kW electric rating, with 1 kW heating elements cast into aluminum blocks. Capacity for 5 ea. 2.5" steam table pans, electronic controls with compensating thermostat, constant steaming and hold cycle controls. Audible Low Water and High Temperature Safety Indicator.

WATTS	VOLTS	PHASE	WIRES	CYCLE HERTZ	AMPS	SUPPLY CONNECTION WIRE SIZE (COPPER)	HEATER RATED VOLTAGE
6000	208	3	3	60	17	12	208
5040	220	3	3	60	14	14	240
6000	240	3	3	60	15	14	240
5040	440	3	3	60	7	14	480
6000	480	3	3	60	8	14	480
9000	208	3	3	60	26	10	208
7560	220	3	3	60	20	12	240
9000	240	3	3	60	22	10	240
7560	440	3	3	60	10	14	480
9000	480	3	3	60	11	14	480

WATTS	VOLTS	PHASE	WIRES	CYCLE HERTZ	AMPS	SUPPLY CONNECTION WIRE SIZE (COPPER)**	HEATER RATED VOLTAGE
6000	208	1	2	60	29	8	208
5040	220	1	2	60	23	10	240
6000	240	1	2	60	25	10	240
N/A	440	N/A	N/A	N/A	N/A	N/A	N/A
6000	480	N/A	N/A	N/A	N/A	N/A	N/A
9000	208	1	2	60	44	6	208
7560	220	1	2	60	35	8	240
9000	240	1	2	60	38	8	240
N/A	440	N/A	N/A	N/A	N/A	N/A	N/A
9000	480	N/A	N/A	N/A	N/A	N/A	N/A

* Consult local authorities for venting and installation requirements.

** For supply connection use only copper wire suitable for at least 75°C (167°F).

Cleveland Range, LLC

Ph: 1-216-481-4900 Fx: 1-216-481-3782

1333 East 179th St., Cleveland, Ohio, U.S.A. 44110

Visit our Web Site at www.clevelandrange.com

CLEVELAND RANGE 1SCE
SEQUENCE OF OPERATIONS
STEAM CUB
Electronic Timer

When using these instructions refer to the STEAM CUB wiring schematic.

1. To turn the unit on, place the 115 VAC switch in the on position.
 - 115 VAC is sent to the H terminal of the water board.
 - 115 VAC is sent through the normally closed contacts (R2A) of the R2 relay to the primary of the 24 VAC transformer.
 - From the secondary of the 24VAC transformer 24 volts is sent to the programmable timer.
2. After water has been placed in the cooking cavity and the probe is grounded the water board will send 115 VAC to the door switch and the coil of R3 closing the normally open contacts to the programmable timer.
 - This tells the timer there is water allowing it to time down.
 - If the water level drops below the probe the water board will stop sending 115 VAC to the coil of R3. This will open the R3 contacts and the timer will display “add h2o”.
 - Without the minimum water level the water board will also prevent 115 VAC from getting to the door switch.
3. With the door closed the door switch is closed and 115 VAC is sent to the normally open contacts of the programmable timer.
 - When the programmable timer is calling for heat (the heat indicator light is energized) 115 VAC is sent to the coil of the heater contactor closing the contacts and energizing the elements.
4. If one of the high limits (located on the heater blocks) open a potential difference is placed across the coil of the R1 relay.
 - The R1 contacts will close energizing the R2 relay coil.
 - The normally open R2B contacts will close latching in the R2 coil.
 - The normally closed R2A contacts will open de-energizing the 24 VAC transformer.
 - The normally open R2A contacts will close energizing the buzzer.
 - The buzzer will sound until the unit is turned off.

SteamCub 6KW / 9KW (THREE PHASE)

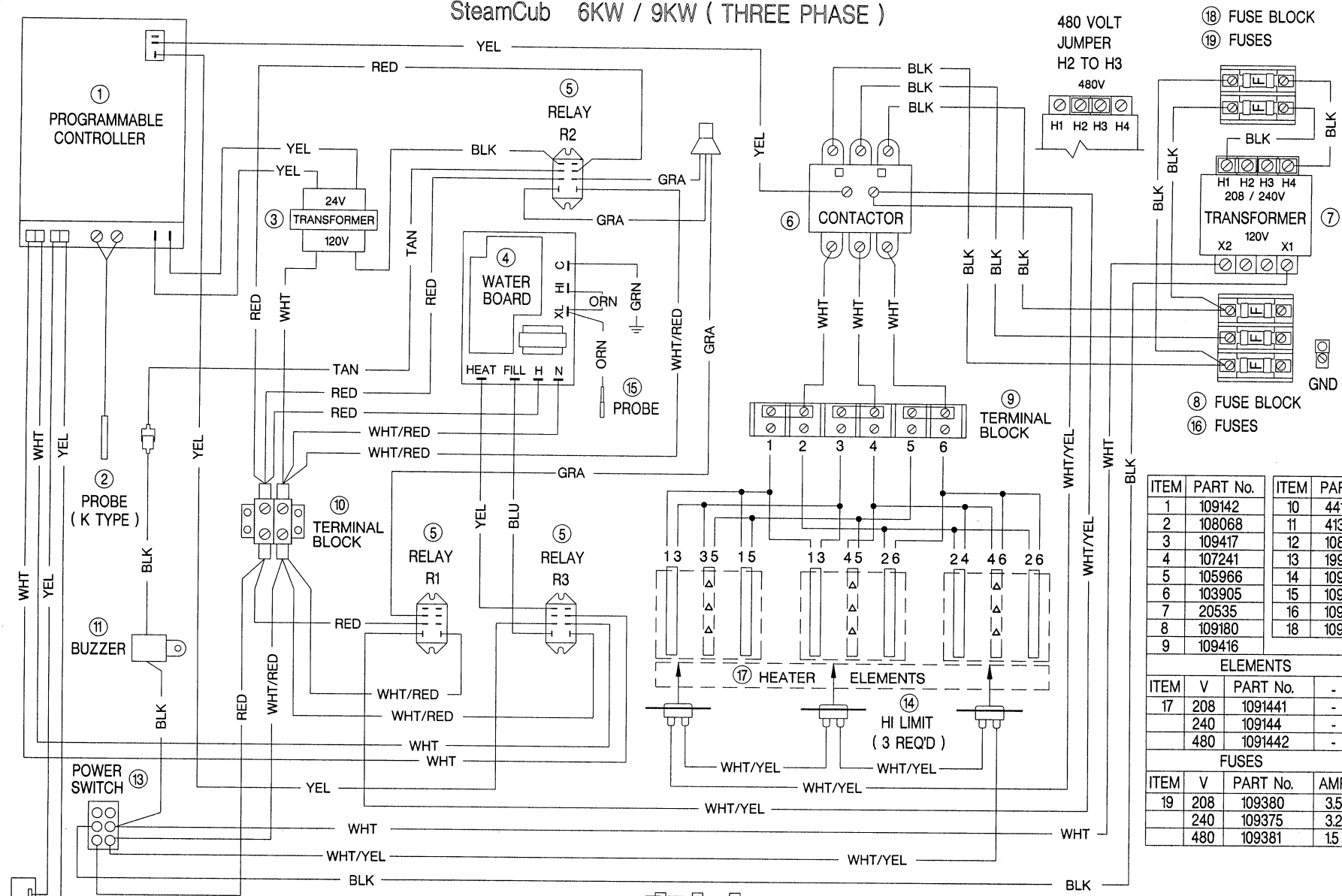

- ⑱ FUSE BLOCK
- ⑲ FUSES

- ⑧ FUSE BLOCK
- ⑯ FUSES

ITEM	PART No.	ITEM	PART No.
1	109142	10	44168
2	108068	11	41350
3	109417	12	108880
4	107241	13	19993
5	105966	14	109152
6	103905	15	109157
7	20535	16	109188
8	109180	18	109374
9	109416		

ELEMENTS			
ITEM	V	PART No.	-
17	208	1091441	-
	240	109144	-
	480	1091442	-

FUSES			
ITEM	V	PART No.	AMP
19	208	109380	3.5
	240	109375	3.2
	480	109381	1.5

NOTE:
 INDICATES ELEMENTS NOT INSTALLED FOR 6KW UNITS

B2

B1

0 TYP 4 PLCS

4.400

STEAMCUB 6KW / 9KW (THREE PHASE)

EL2-EL5-EL8 NOT PRESENT IN 6KW UNITS

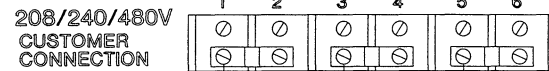
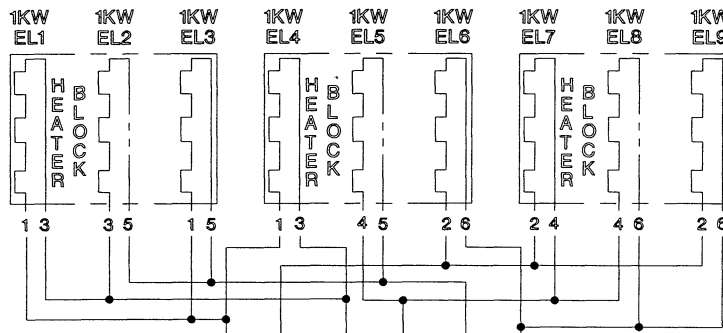

3Ø (SEE RATING PLATE)

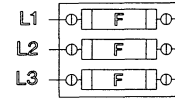

FUSE BLOCK

HEATER CONTACTOR

FIELD CONVERSION FROM 3Ø TO 1Ø IS NOT PERMITTED

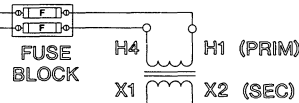

FUSE BLOCK

H4 H1 (PRIM)
X1 X2 (SEC)

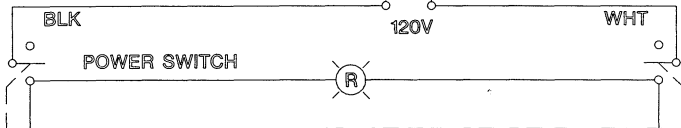

POWER SWITCH

120V

HEATER CONTACTOR COIL
(HEATER BLOCKS)
HI LIMIT SWITCH HI LIMIT SWITCH HI LIMIT SWITCH

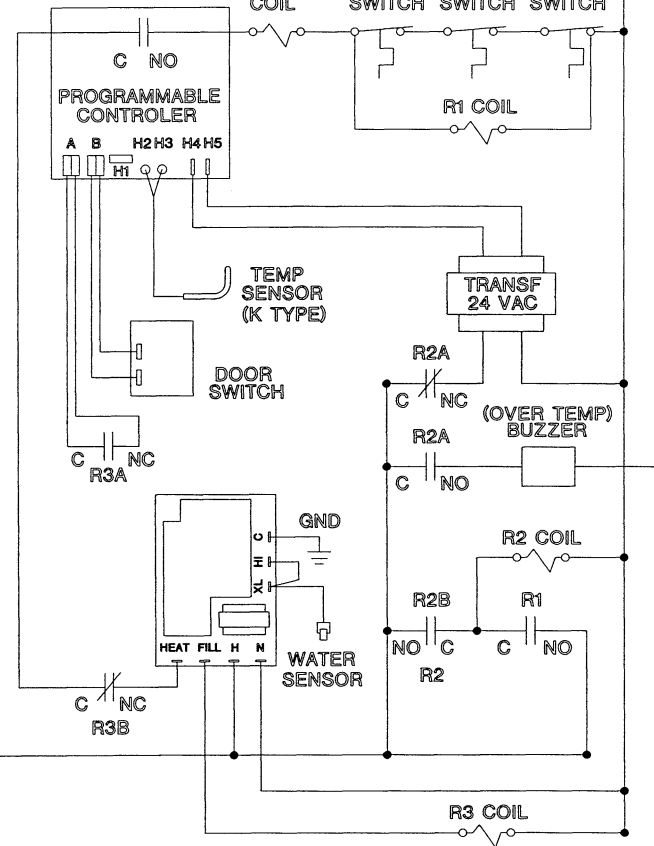

C NO
PROGRAMMABLE CONTROLLER

A B H2 H3 H4 H5
H1

HEATER CONTACTOR COIL
(HEATER BLOCKS)
HI LIMIT SWITCH HI LIMIT SWITCH HI LIMIT SWITCH

R1 COIL

TRANSF 24 VAC

R2A (OVER TEMP) BUZZER

R2 COIL

R3 COIL

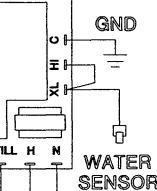

WATER SENSOR

HEAT FILL H N

GND

B2

B1

B3

11.000

109228 B