



Visit www.clevelandrange.com to locate a service or sales representative in your area.

Cleveland

SteamCraft

Electric Convection Steamers with Easy Timer

Operation, Installation & Maintenance Manual

This manual is updated as new information and models are released. Visit our website for the latest manual.

MODELS:

- 21CET8
- 21CET16

For your future reference.

Model # _____

Serial # _____



Read the manual thoroughly. Improper installation, operation or maintenance can cause property damage, injury, or death.

STATEMENT OF RESPONSIBILITIES / DÉCLARATION DES RESPONSABILITÉS / DECLARACIÓN DE RESPONSABILIDADES

This document is for use by experienced and trained Qualified Cleveland Range, LLC Authorized Service Representatives who are familiar with both the safety procedures, and equipment they service. Cleveland Range, LLC assumes no liability for any death, injury, equipment damage, or property damage resulting from use of, improper use of, or failure to use the information contained in this document. Cleveland Range, LLC has made every effort to provide accurate information in this document but cannot guarantee that this document does not contain unintentional errors and omissions.

The information in this document may be subject to technical and technological changes, revisions, or updates. Cleveland Range, LLC assumes no liability or responsibility regarding errata, changes, revisions, or updates.

Qualified Cleveland Range, LLC Authorized Service Representatives are obligated to follow industry standard safety procedures, including, but not limited to, OSHA regulations, and disconnect / lock out / tag out procedures for all utilities including steam, and disconnect / lock out / tag out procedures for gas, electric, and steam powered equipment and / or appliances.

All utilities (gas, electric, water and steam) should be turned OFF to the equipment and locked out of operation according to OSHA approved practices during any servicing of Cleveland Range equipment.

Qualified Cleveland Range, LLC Authorized Service Representatives are obligated to maintain up-to-date knowledge, skills, materials, and equipment.

Ce document est destiné à l'usage des Représentants de Service qualifiés et autorisés de Cleveland Range, LLC qui possèdent l'expérience et la formation ainsi que la bonne connaissance des mesures de sécurité et du matériel qu'ils entretiennent.

Cleveland Range, LLC décline toute responsabilité pour tout cas de décès, blessure, dommage matériel ou dommage aux biens résultant de l'utilisation, de la mauvaise utilisation ou du manquement d'utilisation des renseignements contenus dans ce document.

Cleveland Range, LLC s'est efforcé à fournir des renseignements précis dans ce document mais ne peut garantir que ce document soit exempt d'erreurs et d'omissions non intentionnelles.

Les renseignements contenus dans ce document peuvent être assujettis à des changements techniques et technologiques, des révisions ou des mises à jour.

Cleveland Range, LLC décline toute obligation ou responsabilité concernant les errata, modifications, révisions ou mises à jour.

Les Représentants de Service qualifiés et autorisés de Cleveland Range, LLC sont tenus de se conformer aux mesures de sécurité normalisées de l'industrie, y compris, mais sans s'y limiter, les réglementations de l'OSHA, les procédures de débranchement / verrouillage / étiquetage relatives à tous les services publics, dont l'approvisionnement en vapeur, et les procédures de débranchement / verrouillage / étiquetage relatives aux équipements et/ou appareils fonctionnant au gaz, à l'électricité et à la vapeur.

Au cours de tout entretien d'un appareil Cleveland Range, tous les services publics (gaz, électricité, eau et vapeur) doivent être FERMÉS au niveau de l'appareil et le dispositif de fonctionnement doit être verrouillé suivant les pratiques approuvées de l'OSHA.

Les Représentants de Service qualifiés et autorisés de Cleveland Range, LLC sont tenus d'actualiser en permanence leurs connaissances, compétences, matériel et équipement.

Este documento está destinado para el uso de los Representantes de Servicio calificados y autorizados de Cleveland Range, LLC quienes cuentan con la experiencia y la capacitación, así como el buen conocimiento de las medidas de seguridad y de los equipos que mantienen.

Cleveland Range, LLC, declina toda responsabilidad en caso de cualquier fallecimiento, lesiones, daños al equipo o daños a la propiedad resultantes de la utilización, del uso indebido o de la falta de utilización de la información provista en este documento.

Cleveland Range, LLC se ha esforzado en suministrar información precisa en este documento, pero no puede garantizar que este documento esté exento de errores y de omisiones no intencionales.

La información contenida en este documento podría estar sujeta a cambios técnicos o tecnológicos, revisiones o actualizaciones. Cleveland Range, LLC declina toda obligación o responsabilidad con respecto a erratas, modificaciones, revisiones o actualizaciones.

Los Representantes de Servicio calificados y autorizados de Cleveland Range, LLC tienen la obligación de seguir los procedimientos estándar de seguridad de la industria; los cuales incluyen pero no se limitan a los reglamentos de la OSHA (La Administración de la Seguridad y Salud Ocupacionales), los procedimientos de desconexión, cierre y etiquetado relativos a todos los servicios públicos incluyendo el suministro de vapor y los procedimientos de desconexión, cierre y etiquetado para los equipos y/o aparatos que funcionan a base de gas, electricidad o vapor.

Cuando se esté dando servicio o mantenimiento a un aparato de Cleveland Range, todos los servicios públicos (gas, electricidad, agua y vapor) deben estar APAGADOS para el equipo en cuestión y se debe seguir el procedimiento de cierre de operaciones de acuerdo con las prácticas aprobadas por la OSHA.

Los Representantes de Servicio calificados y autorizados de Cleveland Range, LLC tienen la obligación de actualizar constantemente sus conocimientos, destrezas, materiales y equipamiento.

**FOR YOUR SAFETY / POUR VOTRE SÉCURITÉ /
PARA SU SEGURIDAD**

FOR YOUR SAFETY

Do not store or use gasoline or any other flammable liquids and vapours in the vicinity of this or any other appliance.

WARNING: Improper installation, operation, adjustment, alteration, service, or maintenance can cause property damage, injury or death. Read the installation and operating instructions thoroughly before installing, operating, or servicing this equipment.

Do not spray aerosols in the vicinity of this appliance while it is in operation.

This appliance is not to be used by persons with reduced physical, sensory, or mental capabilities, or lack of experience and knowledge, unless they have been given supervision or instruction concerning use of the appliance by a person responsible for their safety.

This appliance is not for use by children, and they must be supervised not to play with it.

Retain this manual for your reference.

POUR VOTRE SÉCURITÉ

Ne pas entreposer ou utiliser d'essence ou d'autres liquides ou vapeurs inflammables à proximité de cet appareil ou de tout autre appareil.

AVERTISSEMENT : Toute mauvaise pratique en matière d'installation, de fonctionnement, de réglage, de modification, d'entretien ou de maintenance peut causer des dommages matériels, des blessures ou la mort. Lisez la totalité des instructions d'installation et d'utilisation avant d'installer, d'utiliser ou d'entretenir cet équipement.

Ne pas pulvériser des aérosols dans le voisinage de cet appareil alors qu'il est en fonctionnement.

Cet appareil ne doit pas être utilisé par des personnes dont les capacités physiques, sensorielles ou mentales sont réduites, ou des personnes dénuées d'expérience ou de connaissance, sauf si elles ont pu bénéficier, par l'intermédiaire d'une personne responsable de leur sécurité, d'une surveillance ou d'instructions préalables concernant l'utilisation de l'appareil.

Conservez ce manuel pour votre référence.

PARA SU SEGURIDAD

No guarde ni use gasolina o cualesquiera otros líquidos o vapores inflamables en las cercanías de éste o cualquier otro aparato.

ADVERTENCIA: La indebida instalación, operación, ajuste, modificación, servicio o mantenimiento puede ocasionar daños a la propiedad, lesiones o muerte. Lea detenidamente las instrucciones de instalación y de operación antes de instalar, poner a funcionar o dar servicio a este equipo.

No pulverice aerosoles en las proximidades de este aparato mientras está en funcionamiento.

Este aparato no debe ser utilizado por personas con capacidades físicas, sensoriales o mentales reducidas, o que no tengan la experiencia y los conocimientos adecuados, a menos que estas personas hayan recibido supervisión e instrucciones en cuanto al uso del aparato por la persona responsable de la seguridad de ellas.

Guarde este manual para su referencia.

WARNING / AVERTISSEMENT / ADVERTENCIA



Inspect unit daily for proper operation. / Inspecter le bloc quotidiennement pour garantir le fonctionnement normal. / Inspeccione diariamente el funcionamiento correcto de la unidad.



Heavy. / Lourd. / Pesado.

Team or mechanical lift. / Levage en équipe ou mécanique. / Levantamiento en equipo o mecánico.



Surfaces may be extremely hot! Use protective equipment. / Les surfaces peuvent être extrêmement chaudes ! Utiliser des équipements de protection. / ¡Las superficies pueden estar muy calientes! Utilice equipo protector.



Do not climb, sit, or stand on equipment. / Il ne faut pas monter, s'asseoir ni se tenir debout sur l'équipement. / No subirse, ni sentarse ni pararse sobre el equipo.



Do not remove guards or operate without them. / Ne pas supprimer les gardes ou fonctionner sans eux. / No retire los guardias ni funcionar sin ellos.



Keep hands away from moving parts and pinch points. / Tenir les mains à l'abri des pièces mobiles et des angles. / Mantenga las manos lejos de las piezas móviles y los puntos de presión.



Hot product and surfaces. / Produit et surfaces chaudes. / Producto y superficies calientes.



Keep clear of pressure discharge. / Se tenir hors de portée de la purge des soupapes de surpression. / Manténgase alejado de la descarga de presión.



Unit must be anchored as per manual. / Unité doit être ancrée selon les directives du manuel. / Unidad debe estar fijado según el manual.



Floor may become slippery from product spillage. / Déversement de produit peut causer de plancher à être glissant. / Derrame de producto puede causar piso a ser resbaladizo.



Have a qualified service technician maintain your equipment. / Demandez à un technicien en entretien et en réparation qualifié d'effectuer l'entretien de votre équipement. / Haga que un técnico de servicio calificado mantenga su equipo.



Shut off power at main fuse disconnect prior to servicing. / Couper l'alimentation sur le principal fusible sectionneur avant l'entretien. / Apague la alimentación eléctrica en el fusible desconector principal antes de darle servicio.



Ensure equipment is at room temperature and pressure gauge is showing zero or less prior to removing any fittings. / S'assurer que le chaudron se trouve dans une température ambiante et que le manomètre affiche zéro ou moins avant de déposer les raccords. / Asegúrese de que la marmita está a temperatura ambiente y el manómetro está mostrando cero o menos antes de quitar cualquier accesorio.



Appliance must not be supplied through an external switching device that is regularly switched on and off. / L'appareil ne doit pas être alimenté par un interrupteur externe régulièrement allumé et éteint. / El aparato no debe ser alimentado a través de un dispositivo de conmutación externo que se encienda y apague periódicamente.

OPERATION, INSTALLATION & MAINTENANCE MANUAL STEAMCRAFT MODELS 21CET8 & 21CET16

TABLE OF CONTENTS

| | |
|----------------------------------------------------------------------------------------------|-----------|
| CHAPTER 1 GENERAL INFORMATION..... | 5 |
| A. Laws, Codes, and Regulations | 5 |
| B. Operational Safety | 5 |
| C. Inspection for Shipping Damage | 5 |
| CHAPTER 2 PRODUCT INFORMATION | 6 |
| A. Product Information | 6 |
| B. Model Numbers and Serial Numbers | 6 |
| C. Product Information Plate | 6 |
| D. Product Views | 6 |
| CHAPTER 3 INSTALLATION PROCEDURE | 8 |
| A. Select a Location | 8 |
| B. Exhaust Hood Requirements | 8 |
| C. Stands and Stacking Kits | 9 |
| D. Position and Level | 9 |
| E. Install the Slide Racks | 9 |
| F. Connect the Free Air Vented Drain Line | 9 |
| H. Electric Power Supply | 13 |
| I. Installation Checklist | 13 |
| CHAPTER 4 COOKING WITH THE 21CET8/16 | 15 |
| A. Cooking Procedure: | 15 |
| B. Rethermalization: | 16 |
| CHAPTER 5 EASY TIMER OPERATING INSTRUCTIONS | 17 |
| A. Main External Power Switch | 18 |
| B. Inspect the Cooking Compartments..... | 18 |
| C. Power ON (Auto Water Fill / Automatic Preheat)..... | 18 |
| D. Preheat Steamer | 19 |
| E. Instant Steam Standby Feature | 19 |
| CHAPTER 6 SHUTDOWN AND CLEANING PROCEDURE | 20 |
| A. Steam Generator Blowdown | 20 |
| B. Shutdown and Cleaning | 20 |
| CHAPTER 7 OPERATING TESTS AND FINAL CHECKOUT PROCEDURES | 22 |
| A. Startup Procedure | 22 |
| B. Drain Rinse Inspection (continue from Startup Procedure) | 22 |
| C. Operating Tests and Final Checkout Procedure (Continue from Drain Rinse Inspection) | 22 |
| D. Shutdown (Continue from Operating Tests and Final Checkout Procedure) | 24 |
| CHAPTER 8 PREVENTATIVE MAINTENANCE | 25 |
| A. Maintenance..... | 25 |
| CHAPTER 9 TROUBLESHOOTING GUIDE | 29 |

CHAPTER 1 GENERAL INFORMATION

A. Laws, Codes, and Regulations

This equipment should be installed only by qualified, professional plumbers, pipe fitters, and electricians.

1. The installation of this appliance must conform with:
 - a) The National Electrical Code, ANSI/NFPA 70 (latest edition), or the Canadian Electrical Code, CSA C22.2, or local codes, as applicable.
 - When installed, the appliance must be electrically grounded in accordance with the above.
 - **NOTE:** This appliance is not GFI (GFCI) compatible.
 - b) The *Food Code* (latest edition) of the Food and Drug Administration (FDA).
2. This equipment is to be installed to comply with the applicable federal, state, or local plumbing codes.
3. Installation instructions must be read in their entirety before starting installation of this appliance.
4. Install this appliance according to the policies and procedures outlined in this manual.
5. Installation must comply with all local fire and health codes.

DANGER

Improper installation, adjustment, alteration, service, or maintenance of this appliance, or installation of a damaged appliance can result in DEATH, INJURY, EQUIPMENT DAMAGE, and void the warranty.

NEVER install damaged appliances, equipment, or accessories.

ALWAYS have installation and service performed by qualified Cleveland Range authorized personnel.

B. Operational Safety

The Operational Safety section outlines minimum safety policies and procedures for operating one or more Cleveland Range appliances.

1. Do not store anything on top and underneath the appliance.
2. KEEP THE APPLIANCE AREA FREE AND CLEAR OF COMBUSTIBLES.
3. Proper air supply for ventilation is REQUIRED for and CRITICAL to safe, efficient operation of this appliance.
4. Place non-slip draining anti-fatigue mats rated for use in wet, greasy, or dry work areas on the floor in front of the appliance and other locations as needed. Obtain the best mats for your needs from your local supplier.
5. Wear BOOTS appropriate to the work area to help protect feet, and to help prevent slips and falls.
6. Allow only qualified Cleveland Range authorized service representatives to service the appliance.
7. Use only factory authorized repair parts.
8. Maintain written records of appliance service, maintenance, and repair. See Chapter 9.

DANGER

Operating this appliance out of level can cause DEATH, INJURY, and EQUIPMENT DAMAGE.

This appliance must be level both front-to-back and side-to-side in all installations.

NEVER operate this appliance out of level.

If this appliance is suspected to be out of level, shut it down at once and call your qualified Cleveland Range authorized service agency immediately.

C. Inspection for Shipping Damage

If the appliance is damaged or damage is suspected:

1. Submit a Damage Claim to the shipper and inform your dealer immediately.
2. Inform Cleveland Range in writing within three (3) days.

CHAPTER 2 PRODUCT INFORMATION

A. Product Information

- This manual covers the operation of 21CET8 and 21CET16 (Ultra 3 and 5) and the standard features and options available on these appliances.
- Other than selection of options, there are presently no significant design, parts, or operating differences among appliances with these model numbers.
- For further information, contact your Cleveland Range sales representative or Cleveland Range.

B. Model Numbers and Serial Numbers

1. Cleveland Range, LLC assigns two product identification numbers to each appliance: a model number and a serial number.
2. Please provide this information when you contact Cleveland Range or a qualified Cleveland Range authorized service representative:

- Model Number _____
(Write the Model Number of your appliance here)
- Serial Number _____
(Write the Serial Number of your appliance here)

C. Product Information Plate

The Product Information Plate on the back of the appliance lists:

- Model
- Serial number
- Clearances
- Power and wiring requirements

D. Product Views

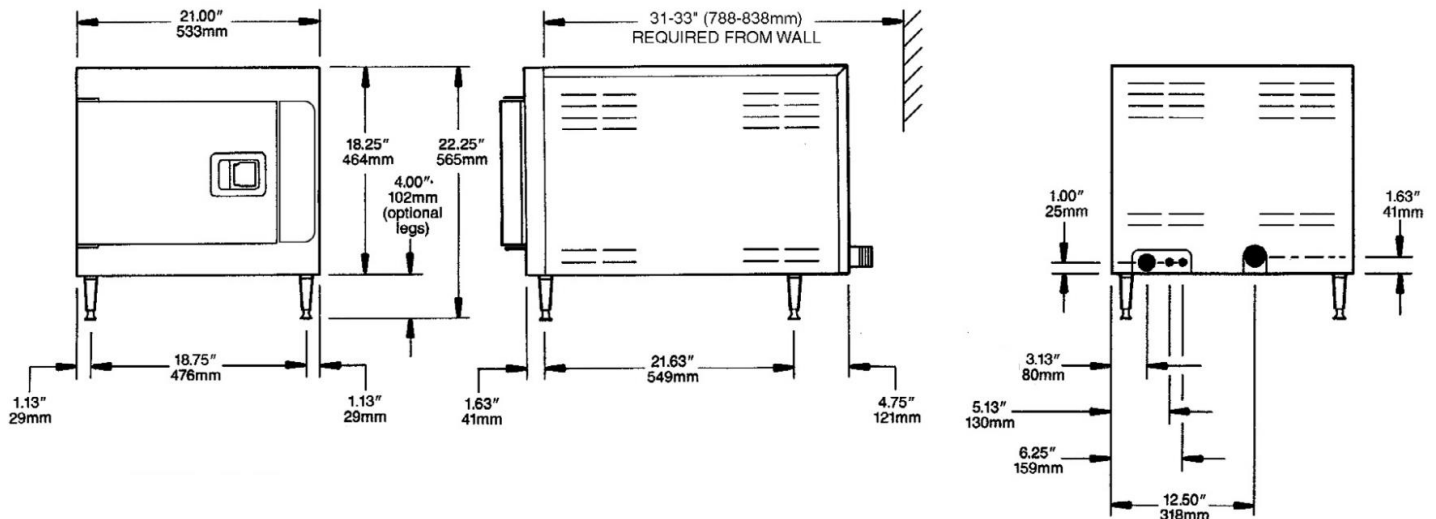

**Figure 2-1 SteamCraft Electric – Front-, Back-, and Right-Side View Dimensions
(Model 21CET8)**

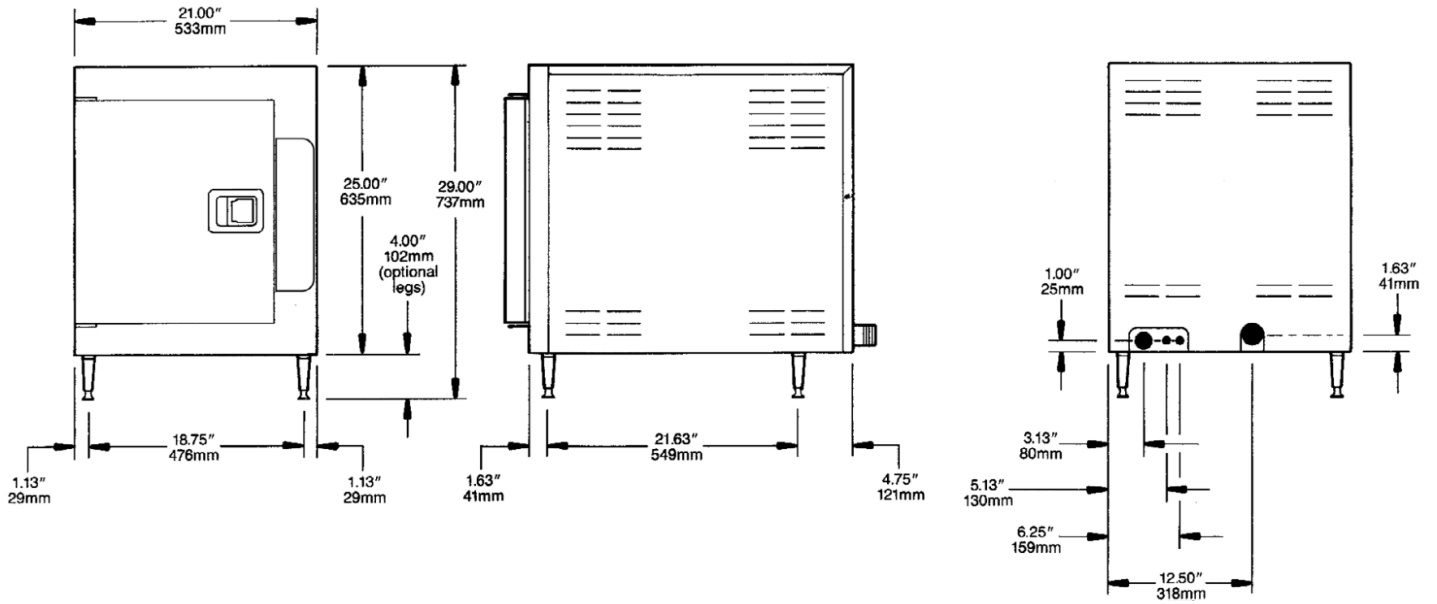

**Figure 2-2 SteamCraft Electric – Front-, Back-, and Right-Side View Dimensions
(Model 21CET16)**

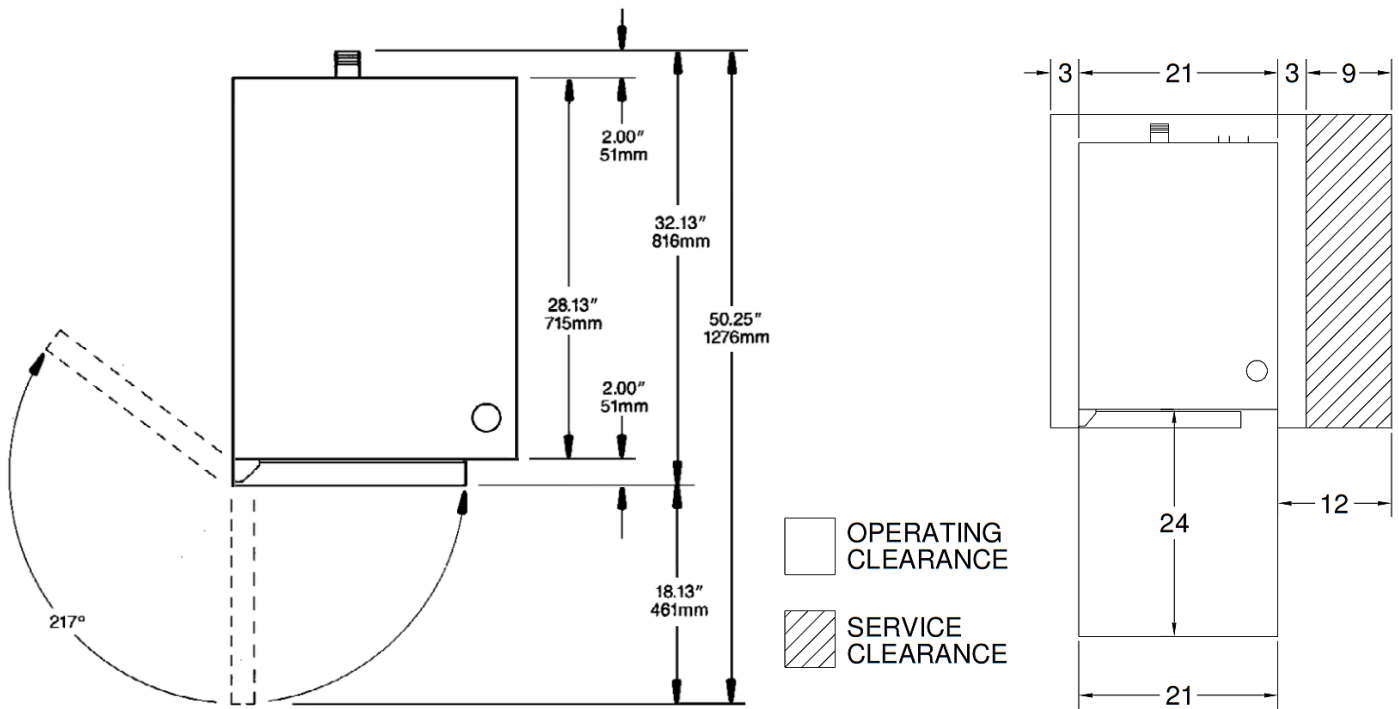

**Figure 2-3 SteamCraft Electric – Top View Dimensions and Clearances
(Model 21CET16)**

CHAPTER 3 INSTALLATION PROCEDURE

DANGER

Operating this appliance out of level can cause DEATH, INJURY, and EQUIPMENT DAMAGE. This appliance must be level both front-to-back and side-to-side in all installations.

NEVER operate this appliance out of level.

If this appliance is suspected to be out of level, shut it down at once and call your qualified Cleveland Range authorized service agency immediately.

A. Select a Location

For safe and efficient operation:

1. Installation must comply with all local fire and health codes.
2. The location selected must be capable of supporting this appliance.
 - The operating weight of a 21CET8 is 179 pounds empty and 274 pounds operational.
 - The operating weight of a 21CET16 is 220 pounds empty and 358 pounds operational.
3. Position the appliance so it will not tip or slide.
4. The operating surface must be level enough to allow leveling with the adjustable legs. This appliance **MUST** be level both front to back and side to side before operation.
5. A suitable drain must be available within 12 feet of this appliance. Do NOT install the appliance directly over a drain.
6. The location must include space for Operating and Service/Secondary Clearances and the Exhaust Hood. See Figure 2-3.

WARNING

All clearance requirements above, below, and around this appliance are the same for non-combustible locations as for combustible locations.

Failure to maintain required clearances and additional distances as needed can result in INJURY and EQUIPMENT DAMAGE.

Consult manufacturers' literature, and sales and service agencies as needed.

7. KEEP THE APPLIANCE AREA FREE AND CLEAR OF COMBUSTIBLES.
8. Proper air supply for ventilation is REQUIRED for and CRITICAL to safe, efficient operation of this appliance.
9. Make sure the air vents of this appliance are not blocked with or by anything.
10. Allow for sufficient extra distance if a "high heat source," e.g., a broiler, is located next to this appliance. Contact Cleveland Range for recommendations.
11. Do NOT install this appliance directly over a drain. Steam rising up out of the drain will adversely affect operation, hamper cooling air circulation, and damage electrical and electronic components.

B. Exhaust Hood Requirements

1. SteamCrafts may be required to be installed under an exhaust hood.
2. If an exhaust hood is required, the hood must extend over the SteamCraft and meet the following requirements:
 - a) The SteamCraft must be vented in accordance with all local, state, and national codes.
 - b) The exhaust hood must be sized for all cumulative ventilation requirements of all the appliances in the area under the hood, including the SteamCraft. See Figure 2-1.
 - c) If an existing hood does not meet all specifications, a new one must be constructed over the SteamCraft.
 - d) The venting hood system must include an interlock to prevent the operation of this appliance without the operation of the ventilation hood if required by state or local code.

C. Stands and Stacking Kits

Stands and Stacking Kits are available for the SteamCraft 21CET8 and 21CET16. Complete instructions are included with the kits.

| SteamCraft Model | Application | Stand | Part Number |
|--------------------|------------------------------------------------------------------------------------------------------------------------------|-----------------------------------------------------|-------------|
| 21CET8 | Stand for 1 SteamCraft | Unistand34 | P/N 111721 |
| 21CET8 | Stacking 2 SteamCrafts | Unistand25 | P/N 111717 |
| | | | |
| 21CET16 | Stand for 1 SteamCraft | Unistand34 | P/N 111721 |
| | | | |
| 21CET8 and 21CET16 | Stand for two (2) 21CET8 OR Stand for two (2) 21CET16 OR Stand for one (1) 21CET8 and one (1) 21CET16 | SteamCraft™ Ultra 3 & 5 Stacking Equipment Stand | P/N ES2446 |

D. Position and Level

1. Move the SteamCraft into position.
2. Using a level, adjust the legs of the 21CET or the legs of the Cleveland Range stand until the 21CET is level front-to-back and side-to-side.

E. Install the Slide Racks

Each rack has four loops: two at the top and two at the bottom. See Figure 3-1.

1. Hold the slide rack so the ends of the hanger loops are toward the side of the cooking compartment.
2. Slide one rack into the compartment with loops toward one side.
3. Hook the loops over the top and bottom pins.
4. Repeat steps 1 to 3 for the other racks.

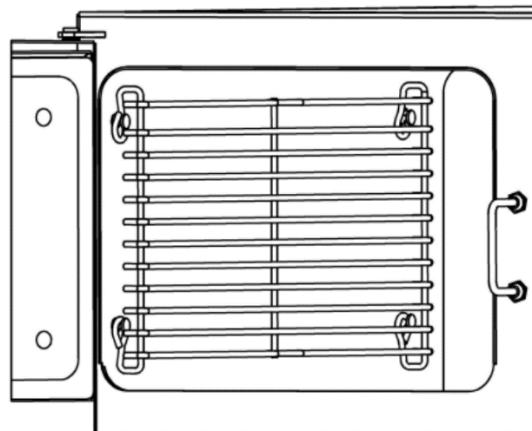

Figure 3-1 Slide Rack

F. Connect the Free Air Vented Drain Line

⚠ DANGER

DEATH, INJURY, EQUIPMENT and PROPERTY DAMAGE will result from improper installation of drain outlet lines.

Install free air vented drain lines as described in this manual.

NOTICE: Furnishing and installing drain lines and drainpipe is the responsibility of the Installer/Owner.

The following restrictions and requirements are critical to the safety of personnel and equipment, and must not be violated under any circumstances:

1. The drain lines must be installed in compliance with the Food Code (latest edition) of the Food and Drug Administration (FDA), and any other applicable national, state, or local codes and regulations.
2. The drain line must be free air vented, have gravity flow from the appliance, and terminate outside the perimeter of the appliance.
3. Free air venting requires a minimum 1" clearance between the end of the drain line and the top of the floor drain. See Figure 2-1.
4. Do NOT install the appliance directly over a drain. Steam rising up out of the drain will adversely affect operation, hamper cooling air circulation, and damage electrical and electronic components.
5. Do NOT connect the appliance's drain connection to any drain material that cannot sustain 140° F.
6. Do NOT connect any other drain from any other equipment to the drain line of this appliance.
7. Do NOT connect the drain outlet extension line directly into a floor drain or a sewer line.
8. Do NOT connect this appliance's drain directly to drains or to the plumbing of any other equipment. (Except when using a Cleveland Range Stacking Stand.)
9. Do NOT install a trap or shutoff in the drain line.

10. Drainpipe Size and Length Guidelines:

- Do NOT make a drainpipe outlet extension more than 12 feet long.
 - If the drain outlet extension requires 6 feet or less of pipe, and no more than two elbows are required, 1 ½ - inch pipe and fittings are acceptable.
 - If the drain outlet extension requires 6 to 12 feet of pipe, or requires three elbows, then 2-inch pipe and fittings are required.
11. Connect the drain to the appliance. See Figure 3-2.
 - Apply a hardening type pipe sealant to the threads when assembling the pipes and fittings of the drain outlet extension.
 - Thread fittings together FINGER TIGHT ONLY! DO NOT USE A WRENCH!

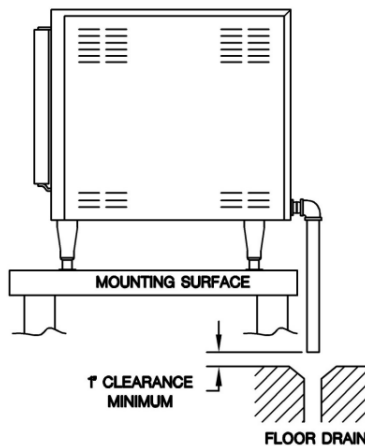

Figure 3-2
Typical Drain Layout

G. Water Supply Requirements and Installation

1. Water Supply Requirements

a) Water Quality

As with any steam generating equipment, poor water quality degrades the performance of the steamer.

Check the quality of supply water as described below before starting construction of the water supply lines. If a water treatment system must be installed to achieve acceptable water quality, install it before connecting the water supply lines to the steamer.

If softened or chlorinated water is used in a SteamCraft steam generator, a carbon type filter must be used for the water before it enters the steamer to remove Chlorine or other salts. If the water supply is treated or softened either by the Water Company or on the premises, it may contain chlorine or various salts. These additives are damaging to the steam generator. Salts and chlorine used to soften or treat water cause rapid scale buildup, and/or increased corrosion if allowed to flow into the steamer.

Contact a local water treatment specialist for an on-the-premises water analysis. The recommended minimum feed water quality requirements for the steamer are listed in Table 3-1.

Table 3-1. Minimum Water Quality Requirements

Scale Forming Factors

| | |
|------------------------|--------------------------------|
| Total Dissolved Solids | less than 60 parts per million |
| Silica | less than 13 parts per million |
| Alkalinity | less than 20 parts per million |

Corrosion-Causing Factors:

| | |
|---------------|---------------------------------|
| Free Chlorine | less than 0.5 parts per million |
| Chloride | less than 30 parts per million |
| PH factor | greater than 7.5 |

b) Water Supply System

- A potable water supply system must be available providing a minimum dynamic pressure of 35 psi (2.4kg/cm²) and a maximum static pressure of 60 psi (4.1 kg/cm²).
- If the static pressure is above 60 psi, a pressure regulator must be used and set at approximately 50 psi. Pressure above 60 psi can damage the solenoid valves.

2. Install the Water Supply Lines

a) Connect the Water Supply Lines

- The Installer/Owner is responsible for the water connection of this appliance.
- This appliance is to be installed to comply with all applicable federal, state, or local plumbing codes.

- **Connect this appliance to COLD WATER** The condenser system and steam generator will not work properly if they are connected to HOT or WARM water.
- Water supply must have a minimum dynamic (flow) pressure of 35 psi and a maximum static pressure of 60 psi.
 - If the static pressure is above 60 psi, a pressure regulator must be used and set at approximately 50 psi. Pressure above 60 psi can damage solenoid valves. See Figures 3-4 and 3-5.
 - SteamCrafts have two ¾" garden hose connection points for incoming water: condenser, and generator.
 - If the water supply meets requirements shown in the Warranty, then the Single Water Supply Arrangement shown in Figure 3-4 may be used.
 - If using a single water feed to the system the supply piping to the tee fitting should be at least the next larger size of pipe than the connection provided on the SteamCraft.
 - If the water supply fails to meet the requirements shown in the Warranty then use the Separate Water Supply Arrangement shown in Figure 3-5.
 - Installation Requirements:
 - Apply non-hardening pipe sealant to all the threaded connections, EXCEPT FOR GARDEN HOSE TYPE THREAD.
 - Install a manual water shut-off valve (not provided) between main cold water supply line(s) and SteamCraft supply lines.
 - This steamer must be installed with adequate backflow prevention in all supply lines, to comply with federal, state, or local codes having jurisdiction.
 - NOTE:** Do not remove the filter washes from the garden hose thread fittings.
 - Construct all supply lines up to the point of installing the strainer.
 - Flush the water supply lines before connecting the lines to the appliance.

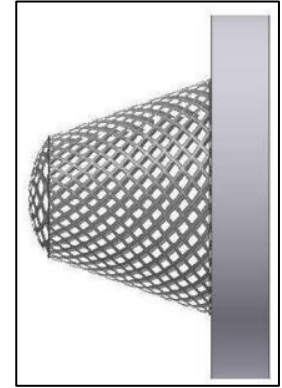

Figure 3-3 Filter Washer
(P/N 110987)

3. Test Water Supply Lines

- Make sure the Main External Power Switch is OFF.
- Remove the control side panel to inspect water connections inside the steamer.
- Check all connections for proper tightness.
- Open the water supply valves.
- Check all lines and connections for leaks, both inside and outside the steamer.

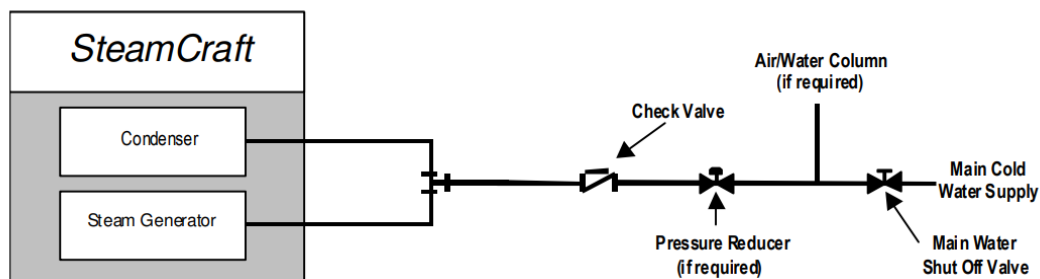

Figure 3-4 Cleveland Range Single Water Supply Arrangement

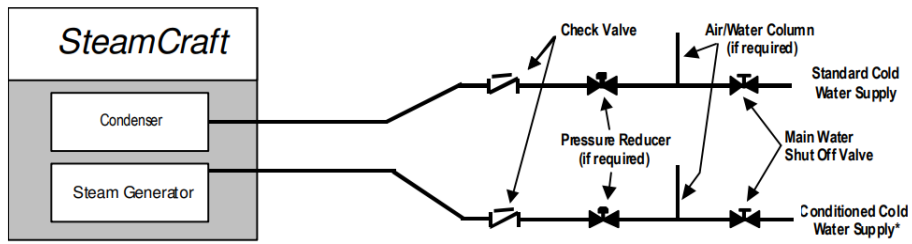

Figure 3-5 Cleveland Range Separate Water Supply Arrangement when Using Separate Conditioned* Feed Water Supply

* “Conditioned” indicates water that has been filtered or treated by a Cleveland Range approved method to meet or exceed the water quality standards listed in the Warranty

H. Electric Power Supply

- The electric supply must match all electrical and wiring requirements specified on the rating plate.
- The wiring diagram and the spare parts list are in the service connection area.
- The main terminals are behind the control side panel in the service connection area.

The connection must be made as follows:

1. Install a main disconnect switch and a separate fuse or breaker for this appliance as shown in Figure 3-6. The fused disconnect switch is called the “Main External Power Switch.”
2. Do not use a GFI (GFCI) circuit. This appliance is not GFI compatible.

⚠ WARNING

This appliance is not GFI (GFCI) compatible. Do not use a GFI (GFCI) circuit.
Using a GFI (GFCI) circuit can result in INJURY, EQUIPMENT and PROPERTY DAMAGE.

3. **Do NOT use a power cord.**
4. Make the electrical connection using flexible conduit, per local code.
5. There should be a sufficient length of flexible conduit between the steamer and the wall so the appliance can be moved for service.
6. Mechanically secure the flexible conduit to the electrical access hole found at the rear of the appliance.
7. Refer to the wiring diagrams and Figure 3-6. Connect the wires to the contactor, side control panel, and ground plug.
8. The appliance must be electrically grounded by the installer.

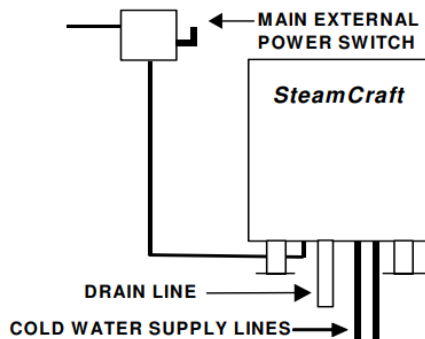

**Figure 3-6
Main External Power Switch**

I. Installation Checklist

| TASK | | REFERENCE | COMPLETED |
|--------------|-------------------------------------|---------------------|-----------|
| Preparation | Check Operating Location Clearances | Chapter 2 Section D | |
| | Test Supply Water Quality | Chapter 3 Section G | |
| | Verify Electric Power Requirements | Chapter 3 Section H | |
| | Verify Exhaust Hood Requirements | Chapter 3 Section B | |
| Installation | Verify SteamCraft is Level | Chapter 3 Section D | |
| | Check Exhaust Hood Function | Chapter 3 Section B | |
| | Check Electrical Supply Connection | Chapter 3 Section H | |
| | Check Water Supply Connection | Chapter 3 Section G | |
| | Leak Test Water Supply Lines | Chapter 3 Section G | |
| | Check Drain Line Connection | Chapter 3 Section F | |

DANGER

Do NOT breathe steam, hot air or condensate. DEATH or INJURY will result.

WARNING

Hot air, steam, and condensate will cause burns and scalds.

To help prevent burns and scalds when opening steamer doors: always stand to the hinge side and back from the doors, slowly open the door, and wait for the steam and heat to dissipate before reaching into the steamer.

The Steamer is a continuously operating appliance, so parts are ALWAYS HOT when the Main External Power Switch or the ON/OFF Switch is in the ON position.

When the ON/OFF Switch is turned to the OFF position, the steamer will remain HOT for some time. Contact with hot surfaces and steam can cause burns and scalds. Avoid contact with hot surfaces and steam.

If the steamer door is stuck shut: DO NOT force the door open.

The door stuck shut may indicate a blocked drain. Hot water can fill the cooking compartment and spill out if the door is forced open causing injury and equipment damage.

If the steamer door is stuck shut:

- Turn OFF the steamer.
- Call a qualified Cleveland Range authorized service technician.
- Wait for the steamer to cool before servicing.

CAUTION

Some food drips juices. Use a solid catch pan under perforated pans when cooking food that drips juices. Dripping juices can cause burns and clog the drain.

Do NOT use oven racks that are bent or damaged in any way.

DO insert pans and accessories LEVEL and INSIDE the oven racks.

Pans and accessories placed in damaged or out of level racks, or outside racks can tip and spill, causing burns, injuries and/or equipment damage.

A. Cooking Procedure:

NOTE: The condenser water does not flow until the cooking compartment reaches the minimum cooking temperature to reduce steam loss and condenser water use.

If condenser flow starts before the cooking compartment reaches cooking temperature, turn OFF the steamer and call your qualified Cleveland Range authorized service representative.

1. Before Cooking or Rethermalizing

- a. Inspect the cooking compartment, drain, and clean as required BEFORE turning ON the SteamCraft. It will be too hot to inspect and clean safely after turning ON. See Chapter 6.
- b. Turn ON and fill the SteamCraft. See Chapter 5 (Easy Timer Operating Instructions).
- c. Preheat the cooking compartment. See Chapter 5 (Easy Timer Operating Instructions).
- d. Slide the pans of food into the slide racks inside the SteamCraft. Do not place pans or anything else on the bottom of the compartment.
- e. For best results, use 2-1/2-inch-deep, perforated pans without covers. These give the best heat transfer and shortest cooking time.
- f. Close the cooking compartment door.

2. Refer to **Easy Timer Operating Instructions** in Chapter 5 to start cooking.
 - While cooking, occasionally check the water in the reservoir for food particles and oils. If the water is dirty or cloudy, change the water. See Chapter 8.
 - The steamer compartment of the Steamer is equipped with an automatic **door interlock switch** that turns off the heating elements and shuts off the condenser when the door to the compartment is opened.

WARNING

Burn and Scald Hazard

Even though the heat shuts off as soon as the door is opened, it may take up to a minute for production of steam to end and residual steam in the system to clear from the cooking compartment.

To help avoid injury, always wait until the residual steam clears before reaching into the cooking compartment, and always wear dry heatproof gloves when reaching into the cooking compartment. Wet or damp gloves conduct heat and can cause burns when touching hot items.

3. After Cooking or Rethermalizing
 - a) Carefully open the cooking compartment door and remove the pans from the slide racks.
 - b) If the steamer will not be used again, perform the **Cleaning Procedure** in Chapter 6.

B. Rethermalization:

- The steamer may also be used to reheat/re-thermalize previously cooked and/or refrigerated foods to serving temperature.
- Depending on initial food temperature and density, most foods will rethermalize to their safe serving temperature in 10 to 40 minutes.
- Always check internal temperature of food with a thermometer to determine that it has been rethermalized to its safe serving temperature.

CHAPTER 5 EASY TIMER OPERATING INSTRUCTIONS



DIGITAL DISPLAY

CONTROL KNOB

Enabled with **TIMED** mode

TIMER START/STOP BUTTON in **TIMED** mode

TIMED/MANUAL SWITCH BUTTON

(Press for 5 sec)



ON-OFF SWITCH

⚠ CAUTION

Press switch and button with fingertips only.

INJURY and **EQUIPMENT DAMAGE** can result from pressing switches and buttons with anything else.

A. Main External Power Switch

Usually, the Main External Power Switch is left ON.

To turn ON the Main External Power Switch:

- Turn the ON/OFF switch to the OFF position.
- Turn ON the Main External Power Switch. See Figure 5-1.

B. Inspect the Cooking Compartments

1. Inspect the cooking compartments while the steamer is cold. After the steamer is turned on, it will be too hot to inspect or clean safely.
2. Before turning ON the power switch to the SteamCraft steamer, make sure the inside of the steamer is clean. See Chapter 6 for complete cleaning instructions.
3. Remove the door gasket assembly, pan racks, and backplate, and make sure all surfaces are clean and drain openings and the water level sensors are clean and free of any residue or debris.
4. Make sure that the drain is clear by pouring about a quart of water through the drain. Make sure that the water flows out the steamer drain.

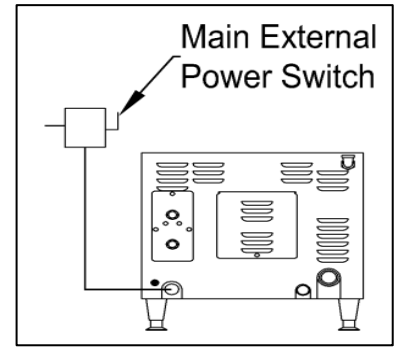

Figure 5-1

Main External Power Switch

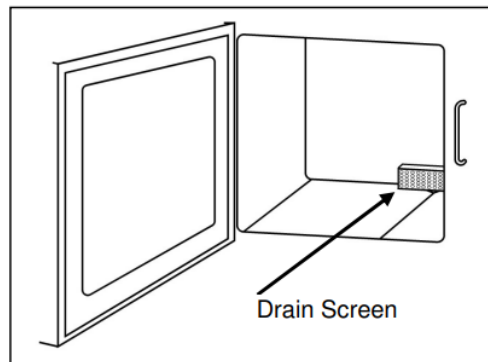

Figure 5-2

Compartment Drain Screen

C. Power ON (Auto Water Fill / Automatic Preheat)

1. Open the water supply valves to the steamer.
2. Turn ON power to the steamer by turning on the ON-OFF SWITCH. The digital display lights and the water reservoir fills.
3. Close the door. When the water reservoir is filled to the minimum operating level the heater turns on and heats the water to the standby cooking temperature.
4. Timed Mode (with "SURE COOK" mode feature)
 - a) Select cooking time using "Control Knob".
 - b) Press "TIMER-START/STOP" button to start cooking.
 - c) "SURE COOK" illuminates on digital display once the compartment reaches 193°F (90°C).
 - d) Timer then starts to countdown until it reaches 00:00.
 - e) Steamer will stop heating and require prompt when the timer reaches 0:00.
5. Manual Mode (Continuous Steaming)
 - a) Press and hold "TIMER-START STOP" button for 5 seconds until switches to Manual mode.
 - b) "MAN" will appear on the digital display when activated and control knob disabled.
 - c) **NOTE:** steamer will go into "Standby" mode if compartment isn't opened for 60 minutes.

6. Changing from Manual to Timed Mode
 - a) Press and hold “TIMER-START/STOP” button for 5 seconds until switching to TIMED mode.
 - b) “TIMED” will appear on the digital display.
 - c) Digital display will display 00:00, and the control knob will be activated.
7. “Descal” Notification
 - a) Easy Timer comes with 400 hours operation for “Descaling Notification.”
 - b) After 400 hours, “DESCALE” appears on digital display for 5 seconds and will re-appear every 5 minutes.
8. Reset and Clear Descal Notification
 - a) Turn OFF main power with POWER SWITCH.
 - b) Press and hold the “TIMER-START/STOP” button.
 - c) Power unit ON with main POWER SWITCH (with “TIMER START/STOP” Button held).
 - d) Wait 10 seconds to Reset/Clearing Mode.
 - e) The Beeper starts beeping once every second.
 - f) Release the “TIMER-START/STOP” button.
 - g) Display will show “RST”.
 - h) Press the “TIMER-START/STOP” button to confirm resetting descale notification.
9. Program Number of Hours until Descal Notification
 - a) Turn OFF main power with POWER SWITCH.
 - b) Press and hold the “TIMER-START/STOP” Button.
 - c) Power unit ON with main POWER SWITCH (with “TIMER START/STOP” button held).
 - d) Wait 20 seconds to enter Programming Mode (to change the Max number of hours)
 - e) The Beeper starts beeping twice every second.
 - f) Release the “TIMER-START/STOP” button.
 - g) Display will show past settings.
 - h) Turn knob to adjust the number of hours.
 - i) Press “TIMER-START/STOP” button to save number of hours for next descale notification.

D. Preheat Steamer

Preheat steamer to ensure productivity and consistency. **BEFORE PREHEATING:** Inspect and clean the compartment. After preheating, the compartment will be too hot to inspect and clean safely.

To preheat the SteamCraft Steamer:

1. Close the steamer door and turn the steamer ON 15 minutes before cooking.
2. The steamer will heat to the standby temperature.

E. Instant Steam Standby Feature

The 21CET8 and 21CET16 steamers have an Instant Steam Standby feature to keep the water in the steam generator near steaming temperature between cooking operations.

CHAPTER 6 SHUTDOWN AND CLEANING PROCEDURE

A. Steam Generator Blowdown

1. Power Off

- When the appliance is turned OFF at the ON/OFF switch, blowdown starts automatically.
The generator is drained, and the drain valve is rinsed with fresh water to help prevent scale.

2. Blowdown Frequency

- a) Based on the water quality analysis done before installation, and the amount of use, make, and post a blowdown schedule.
 - Contact your qualified Cleveland Range authorized service agency or Cleveland Range for more information about maintenance scheduling, products, and services.
- b) Blowdown Schedule Guidelines:
 - 1) When using water that does not meet the minimum water quality standards (see the Warranty), blowdown must be performed after every 4 hours of operation, or more frequently as required, and at the end of each shift.
 - 2) For appliances using water that meets the minimum water quality standards, blowdown must be performed at the end of each shift.

3. Blowdown Procedure

- a) Follow the Shutdown instructions in Chapter 7.
- b) EITHER restart the appliance by following the Startup Procedure in Chapter 7, OR if the appliance will not be used again during this shift, go to “Shut Down and Cleaning.”

B. Shutdown and Cleaning

- Perform the Shutdown and Cleaning Procedure at the end of each shift or more often if needed.

WARNING

ELECTRIC SHOCK HAZARD

Do not clean this appliance with hoses or water jets!
Doing so can cause INJURY and EQUIPMENT DAMAGE.

DANGER

HIGH HEAT HAZARD

Wait for this appliance to cool before cleaning. Attempting to clean a hot appliance can cause DEATH, INJURY, BURNS, and SCALDS.

Shutdown and Cleaning Procedure for the End of Each Shift:

1. Follow the Shutdown instructions in Chapter 7.
2. Open the cooking compartment door and allow the appliance to cool.
3. Remove the slide racks. Wash, and rinse them according to health and sanitation requirements.
4. Remove spilled food from inside the compartments. Use a soft bristle brush to remove stuck food.
5. Clean but do not remove the drain screens.
6. Clean the interior of the compartment thoroughly.
 - Do NOT use abrasive cleaning compounds or steel wool.
7. Rinse the inside of the cooking compartments with clean water.
8. Clean the door gasket assemblies:

- a) Remove the door gasket assembly (see Figure 6-1) by holding the gasket assembly at the sides and lifting up and away from the door.
- b) Wipe the gasket assembly with a damp cloth.
- c) Wipe the inside of the door with a damp cloth.
- d) Rotate the gasket assembly 180°. This makes the gasket last longer.
- e) Replace the gasket assembly by sliding the retaining pins into the keyhole slots.

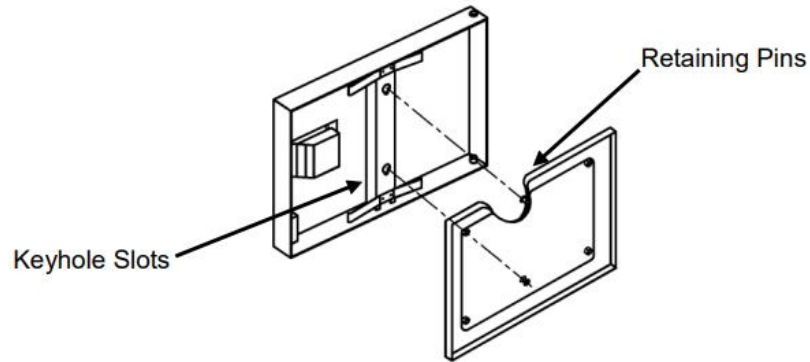

Figure 6-1
Door Gasket Assembly

9. Replace the cleaned slide racks.
10. Wipe the exterior with a damp cloth.
11. Leave cooking compartment doors open until the next use to help prevent compartment odor buildup and help increase gasket life.

CHAPTER 7 OPERATING TESTS AND FINAL CHECKOUT PROCEDURES

- **This procedure must be performed by a qualified Cleveland Range authorized service representative.**
- Complete the Startup Procedure before starting the actual operating tests.
- Read and understand all steps of this procedure before starting.
- This procedure evaluates the function of the major operating controls of a SteamCraft.
- This procedure is for SteamCrafts equipped with an Easy Timer control panel.

A. Startup Procedure

1. Set the ON/OFF Switch to OFF and open the steamer door. There should be no water in the steamer.
2. Make sure that the reservoir drains are clear.
3. Check for proper installation of the backplate, slide racks, and door gasket assembly.
4. Make sure the Main External Power Switch is OFF.
5. Make sure the fuses or breakers are the proper size.
6. Remove the control side access cover.
7. Check the internal wiring and make sure there are no loose or disconnected wires.
8. Make sure the supply wiring is the correct size.
9. Check that the appliance is properly grounded.
10. Correct any deficiencies.

B. Drain Rinse Inspection (continue from Startup Procedure)

1. Turn OFF the ON/OFF switch.
2. Turn ON the water supply to the steamer.
3. Turn ON the Main External Power Switch.
4. The 3-minute drain rinse cycle starts.
5. The drain is flushed with fresh water.
6. Stop the drain rinse cycle before it is complete by setting the ON/OFF switch to ON.
7. Drain rinse stops.
8. The operating control circuits energize.
9. The digital display is ON, and the message "SURE COOK" is displayed.
10. The reservoir begins to fill with water.
11. Restart the drain rinse cycle by setting the ON/OFF switch to OFF.
12. During the drain rinse cycle, make the following checks:
 - a) The ON/OFF switch must be turned OFF to start the drain rinse cycle.
 - b) Look at the one-inch vent gap between the steamer drainpipe and the floor drain. A steady stream of water drains from the steamer.
 - c) Check for plumbing leaks.
 - d) After about 3 minutes, the cycle is complete.
 - e) Look at the one-inch vent gap between the steamer drainpipe and the floor drain. No more water drains from the steamer.

C. Operating Tests and Final Checkout Procedure (Continue from Drain Rinse Inspection)

1. Turn ON the Main External Power Switch.
2. Open the cooking compartment door.
3. Turn ON the ON/OFF switch. The reservoir begins to fill with water.

4. As the reservoir fills with water, check that the digital display is ON and displays the "SURE COOK" message.
5. Close the compartment door to close the door interlock circuit.
6. As the water level in the compartment reservoir rises:
 - a) No water flows from the drain opening.
 - b) Check for plumbing leaks in the control compartment.
7. When the water in the reservoir reaches the level of the lower probe, the heating elements turn ON and the steamer heats to the standby temperature.
8. Open the door; the heating elements turn OFF.
 - a) The water level in the reservoir continues to rise.
 - b) The water in the reservoir stops rising when water reaches the upper probe.
 - If the water level continues to rise above the tip of the higher probe, turn OFF the ON/OFF switch and see the **Operators Troubleshooting Guide**.
 - If the problem persists, shut down the appliance and call a qualified Cleveland Range authorized service representative.
9. Close the compartment door.
 - a) The contactor will engage, and water will flow from the drain and steam will fill the cavity.
 - b) The Easy Timer will chirp twice, and the screen will show this sequence: "TIME", "REMAINING TIME", "SURECOOK" before 193°F.
 - c) After 193°F, the Easy Timer should chirp once, and the timer will start counting down. The screen will show "REMAINING TIME" throughout the cycle.
 - d) If "Time/Man" button is pressed for 3 seconds, the EZ Timer will chirp 3 times, contactors will deenergize, and the water stops.
10. Switch to MANUAL mode.
 - a) To switch to manual mode or vice versa (can be done anytime during operation), press and hold Timed/Manual button for 5 seconds.
 - b) Easy Timer will chirp once and then show time remaining for one second and then "MAN" mode.
 - c) Turn the encoder in any direction and verify it has no effect on time operation.
 - d) Based on the cavity temperature, either below 193°F or above, Easy Timer screen will show in sequence, "MAN", "Remaining Time", "SURECOOK", or "MAN".
 - e) Heating Contactor will energize, and steam will fill the cavity, and continue with no shutdown for 1 hour.
11. As the appliance continues to steam in Manual Mode, test the no-water/low water safety circuit.
 - a) Close the manual water supply valve(s).
 - b) When the water level drops below the lower water safety cutoff point (the lower probe). The heating elements, the condenser water flow will automatically shut off, and the production of steam will cease.
 - c) Open the manual water supply valve(s). The reservoir refills with water to the safety level and steaming resumes.
12. Switch to TIMED mode and set the Timer to zero.
 - a) The steam generating cycle stops.
 - b) The heating elements and condenser turn OFF.
 - c) Steam production stops and the compartment returns to standby mode.
13. Open the cooking compartment door and allow the compartment to cool for 3 minutes, then close the door and continue testing.
14. Switch to TIMED mode.
15. Set the Timer for 10 minutes.
16. As soon as the Timer is set, the steam generating cycle starts. This is the same sequence observed in

manual mode, except:

- a) The Timer controls the cycle.
- b) The elapsed time to produce steam is shorter because the water in the steam generator and the cooking compartment are already hot.
- c) The cooking compartment returns to Standby temperature after the Timer counts down to zero.

17. After timed operation starts, check the following:

- a) The heating elements turn on immediately.
- b) The "SURE COOK" message may display depending on compartment temperature.
- c) The "SURE COOK" message displays until the compartment reaches the minimum cooking temperature.
- d) When the "SURE COOK" message turns OFF, the Timer begins counting down to zero and the condenser cycles as needed.
- e) As steam is generated, the water level fluctuates, and the solenoid makes a clicking sound when it opens and closes the fill valve.
- f) Check for steam leaks around the door.
- g) When the timer reaches zero, the Easy Timer should chirp continuously, screen will flash "00:00" until Timed/Manual button is pressed (Easy Timer will chirp 3 times).
- h) The screen will return to its original setup, "00:00" and condenser should stop, and steamer will stay on standby.
- i) After about 30 seconds steam stops being produced.

18. Go to step D, "Shutdown."

D. Shutdown (Continue from Operating Tests and Final Checkout Procedure)

1. Turn the steamer OFF by turning the ON/OFF switch to the OFF position.
 - a) The digital display turns OFF.
 - b) The 3-minute automatic drain rinse cycle starts.
2. When the drain rinse is complete, turn the steamer OFF at the main external power switch.
3. Replace the side panels and secure them with their screws.
4. After completing the Startup, Drain Rinse Inspection, and the Operating Tests and Final Checkout Procedure, the appliance is ready for service.

CHAPTER 8 PREVENTATIVE MAINTENANCE

A. Maintenance

Maintenance on the steamer must be performed on a regular basis to keep it running properly and efficiently. By following the maintenance instructions in this chapter and cleaning the equipment regularly as outlined in Chapter 6, problems with the steamer will be kept to a minimum. The frequency of steamer maintenance may need to be increased, depending on equipment usage and water quality. If problems occur, refer to the **Troubleshooting Guide**. For more information on product and services, contact your sales representative.

1. Maintenance Records

Make a file for maintenance and repair records only. Keep a written record of daily, weekly, monthly, and yearly maintenance. These records will help protect warranty coverage, help schedule maintenance procedures, help keep the steamer cooking properly, and assist service personnel.

2. Daily Maintenance

- a) Blowdown
 - Blowdown the steam generator. Follow the instructions in Chapter 6.
- b) Clean the Appliance
 - Clean the interior and exterior of the appliance. Follow the instructions in Chapter 6.

3. Weekly Maintenance

- a) Clean the Cooking Compartment Drains
 - Blockage of the drain line can cause pressure buildup in the compartment(s) resulting in steam leaks around the door gasket(s), reduced performance, and compartment implosion.
- b) To inspect the drain screens and the drain lines for blockage:
 - 1) Clean the cooking compartment and drain screens. Follow the instructions in Chapter 6.
 - 2) Rotate the drain screen 90 degrees to inspect the drain opening.
 - 3) Clean the opening and put the screen back into their operating position.
 - 4) Pour a quart of water into the cooking compartment. If the water drains slowly or stands, clean the cooking compartment drains with a NSF/FDA approved drain cleaner.
 - Follow the instructions of the drain cleaner manufacturer.
 - Flush the cooking compartments and drains with clean water.

4. Monthly Maintenance

- a) Descale the Steam Generator
 - Steam Generators should be descaled once a month or after 400 hours, whichever comes first.
 - Note the date of descaling in your maintenance and service records to help keep Steam Generator descaling on schedule.
- b) SteamCraft Descaling Procedure Using the Descaling Pump System
 - Cleveland Range recommends that your service agency descales your 21CET8 and 21CET16.
 - If you have trained and skilled in-house maintenance personnel, you may wish to discuss purchasing Descaling Pump System P/N: [1071421](#) for use with Dissolve® Descaler Solution P/N [106174](#) with your sales representative or service agency.
 - Use no other system of descaling.
- c) Manual Method to Descale Steam Generator

NOTE: Part No. [106174](#) is the Part No. for a case (6 1-gallon containers) of DISSOLVE® descaler.

THESE INSTRUCTIONS ARE FOR USE WITH DISSOLVE® DESCALER SOLUTION Cleveland Range Part No. [106174](#).

1) Health Hazard Data, Effects of Overexposure

- This product may cause a burning sensation to eyes or skin.

2) Emergency and First Aid Procedures

- In case of eye contact, immediately flush eyes with water for 15 minutes. If irritation persists seek medical attention.
- In case of skin contact wash with soap and water.
- If inhaled, remove to fresh air. If burning persists, call a physician.
- If ingested, take 1 or 2 glasses of water and call a physician.

3) Spill or Leak Procedures

- Rinse with plenty of water to dilute.
- Sodium carbonate or calcium carbonate may be used to soak up liquid.
- Considered non-hazardous, spent material may be disposed of in a sewer system with water flush.

⚠ CAUTION

Do not use any other product or method of descaling other than the DISSOLVE® Descaler method using Part No. [106174](#).

⚠ WARNING

Descaling procedure is slightly different depending on model. This entire procedure should be read and fully understood as it applies to the model being descaled, before beginning descaling operations.

⚠ DANGER

The liquid solution in Cleveland Range Descaler Solution Part No. [106174](#) or [1061741](#) can be harmful if not handled properly. Follow these basic safety rules for handling and using this product. Instructions and warnings on container labels supersede all other warnings and instructions.

Wear protective clothing when mixing or applying chemical cleaners.

Wear rubber gloves, and OSHA approved eye protection when descaling.

Avoid breathing fumes.

NOTICES regarding the Manual Descaling Procedure

- Cleveland Range recommends DISSOLVE® Descaler Solution, Part No. [106174](#).
- Use no other system of steamer descaling.
- Appropriate warnings and safe handling procedures must be provided to handlers and users.
- Instructions and warnings on Dissolve® containers and Material Safety Data Sheets supersede and replace instructions and warnings in this manual.
- General precautions: wear rubber gloves, splash goggles and other protective clothing and equipment as necessary.
- Refer to Dissolve® container labels and Material Safety Data Sheets for information regarding eyewash, first aid, medical treatment, and spill control.

d) Descaling Procedure

- Turn steamer OFF and open door(s)



Figure 8-1
Descal Port

- 3 minute Automatic Blowdown cycle runs.
- ii. Turn steamer ON
 - Generator begins to refill.
 - iii. DO NOT start timer.
 - **Water must be cold for descaling.**
 - Open cooking compartment door(s).
 - **Leave cooking compartment door(s) open to PREVENT HEATING.**
 - iv. Remove descaling port cap (see Figure 8-1)
 - v. Add 1 gallon of Dissolve® through the descale port while generator refills.
 - Pour slowly to avoid overflow.
 - Refill can take up to 8 minutes.
 - vi. Add 1-2 gallons of cold tap water to descaling port after refill stops, continue to fill with cold water until descaling solution enters cooking compartment(s) through steam nozzles.
 - **NOTE:** Some descaling solution will flow from drain of Ultra 10 gas steamers.
 - Adding extra water to generator raises descaling solution to higher than normal water fill level, allowing descaling solution to clean sensors and surfaces above normal water fill level.
 - vii. Let descaling solution soak in generator for 1 hour.
 - viii. After 1 hour, turn ON/OFF switch OFF to start 3 minute Automatic Blowdown.
 - This drains and rinses generator.
 - ix. After Automatic Blowdown ends, turn ON/OFF switch to ON.
 - x. Add cold tap water through descaling port after generator refills, until water enters cooking compartment(s) through steam nozzles.
 - This raises the water level to rinse the surfaces cleaned in Step 8.
 - xi. Turn ON/OFF switch OFF to start 3 minute Automatic Blowdown to rinse generator.
 - xii. Replace descaling cap and close cooking compartment door(s).
 - xiii. Turn steamer ON/OFF switch to ON and set TIMER for 20 minutes.
 - xiv. After the timer counts down, turn ON/OFF switch to OFF to start Automatic Blowdown.
 - xv. Descaling is complete, resume normal startup, cooking, and shutdown procedures.

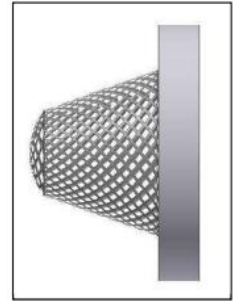









Figure 8-2
Filter Washer
Assembly
(P/N 110987)

e) Program Descale

After descaling, verify descale time is set to 400 hours by default.

- Power OFF the unit. Press and keep pressed the TIME  button. Power ON unit (keep pressed the TIME  button)
- Wait 20 sec, to enter Programming Mode (to change the max number of hours). The Beeper starts beeping twice every sec.
- Release the Time  button, display will show the past set number of hrs.
- Turn the knob to set the number of hrs.
- Press the Time  button to save the number of hrs. The unit will stay on and be ready to use.

Reset Descaling:

- Power the unit OFF. Press and keep pressed the TIME  button. Power ON unit (keep pressed the TIME  button)
- Wait 10 sec, to enter RESET Mode. The EZ timer will chirp once every sec.
- Release the TIME  button, display will show **RST**. Press the TIME  button to reset the time.
- Unit will stay on and be ready to use.

If the Descaling set time reached during operation (Manual or Timed mode)

Timed mode:

| | | | | | | | | | |
|------------------|------|------|-------------------|------|-------------------|------|-------------------|------|------|
| Show: | | TIME | Remaining seconds | dSCL | Remaining seconds | TIME | Remaining seconds | dSCL | |
| How long: | | 2sec | 10sec | 5sec | 10sec | 2sec | 10sec | 5sec | |

Manual mode:

| | | | | | |
|------------------|--------|--------|--------|--------|-----------|
| Show: | "MAN , | dSCL, | MAN, | dSCL, | MAN" |
| How long: | 15 sec | 15 sec | 15 sec | 15 sec | 15 sec |

5. Yearly Maintenance

- a) Clean the Water Line Strainer (Filter washers)

Clean the water line strainers at least once a year.

NOTE: When the steamer is first installed, check the strainer more frequently to find out how often the strainer must be cleaned.

- 1) Turn OFF power to the steamer at the Main External Power Switch.
- 2) Close the valves in the steamer water supply lines.
- 3) Unscrew the hoses from the inlet fittings located on the rear of the steamer.
- 4) Remove the filter washers from the outlet of the water connection hoses, at the rear of the unit and wash them with clean water.
- 5) Check the filter washer for wear and replace it if necessary.
- 6) Put the filter washers into each of the water inlets and reconnect the hoses to the back of the steamer.
- 7) If treated water is used to supply water to the reservoir, make sure that it is connected to the generator inlet at the rear of the steamer.
- 8) Open water supply valve(s) and check for water leaks.
- 9) Turn power back on to the steamer at the Main External Power Switch.

NOTE: The appliance will perform the automatic 3-minute drain rinse cycle

CHAPTER 9 TROUBLESHOOTING GUIDE

The Troubleshooting Guide is a list of symptoms of problems that may occur during routine operation.

- “Problem” (left column) lists common operating problems.
- “Possible Cause” (center column) lists causes of problems in the order they should be checked.
- “Remedy / Reference” (right column) lists fixes for problems from easiest to hardest.
- “Notes” in “Remedy / Reference” column are at end of the Troubleshooting Guide.

ATTEMPTING TO REPAIR OR CORRECT PROBLEMS REQUIRING A QUALIFIED CLEVELAND RANGE AUTHORIZED SERVICE REPRESENTATIVE VOIDS THE WARRANTY.

| PROBLEM | POSSIBLE CAUSE | REMEDY/REFERENCE |
|---------------------------------------------------------------------------------------------|--------------------------------------------------------------------------------|----------------------------------------------------------------------------------|
| Digital display does not turn ON when ON/OFF switch is in the ON position. | Power turned OFF at Main External Power Switch. | Turn ON power at Main External Power Switch. |
| | ON/OFF switch not fully turned to the ON position. | Turn switch to the ON position. |
| | Inoperative controls or indicators. | See Note 1. |
| Power ON and appliance does not fill with water. | Water supply to appliance shut OFF. | Open water supply lines. |
| | Water line strainer and/or external filter system clogged. | Clean water supply strainer and/or filter system. See Yearly Maintenance. |
| | Water sensor is grounded by detergent film, or scale. | Clean water sensor assembly with vinegar solution. See Chapter 6. |
| | Inoperative controls or solenoids. | See Note 1. |
| Digital Display is on, buzzer sounds continuously, reset indicator is lit. | High limit has been tripped. | Reset steamer. If problem repeats, see Note 1. |
| | Inoperative controls. | See Note 1. |
| Compartment bottom dirty with food drippings. | Juices and/or food leaking from pans or spilling during loading and unloading. | Put a solid pan under perforated pans to catch drippings. Put less food in pans. |
| Digital display turns ON and steamer does not heat to cooking temperature or produce steam. | Door interlock switch not engaged. | Close door completely. |
| | Water supply to steamer closed. | Open water supply lines. |
| | Water line strainer and/or external filter system clogged. | Clean water supply strainer and/or filter system. See Yearly Maintenance. |
| | Appliance is in the Timed Mode and timer is not set. | Change to Manual Mode or set the timer. |
| | High limit switch has tripped. | Reset steamer. If condition repeats, see Note 1. |
| | Bottom of reservoir is heavily scaled. | See Note 1 or 7. |
| | Inoperative controls. | See Note 1. |
| Abnormal amount of steam coming from drain during draining of steamer. | ON/OFF switch is not fully OFF. | Turn switch to OFF to activate the drain cooling feature. |
| | Water line strainer and/or external filter system clogged. | Clean water supply strainer and filter system. |
| | Hot water instead of cold water connected to reservoir fill line | See Note 2 and 3. |
| | Inoperative controls. | See Note 1. |
| Steam and/or water | The vent and/or the drain to the vent is clogged | Clear vent and collector openings. Clean |

| | | |
|------------------------------------------------------------------------------------------------|--------------------------------------------------------------------------------------------------------------------------------------|-------------------------------------------------------------------------------------------------------------------------|
| draining around the compartment door. See Warning under Note 7. | or covered. | the drain with NSF approved drain cleaner and flush drain thoroughly with fresh water If condition persists see Note 1. |
| | Water Sensor dirty | Clean sensor thoroughly |
| | Door gasket or door parts worn. | See Note 1. |
| | Hot water instead of cold water connected to the condenser water line | See Note 2 and 3. |
| | External drain or vent not properly sized, installed, free air vented, and/or pitched down. | Make sure the drain is sized and installed properly. See Installation Manual. See Notes 2 and 3. |
| | Steamer not level. | See Note 2. |
| | Drain is blocked. | Clean drain with NSF approved drain cleaner. If problem persists, see Note 1. |
| Steam coming out of the exhaust. | Inoperative controls | See Note 1. |
| | A small amount of steam may issue from the exhaust whenever the unit is in the cooking mode. | This is normal operation of the steamer NO action is necessary. |
| | Condenser water supply is turned OFF | Turn ON Condenser water supply |
| | Water line strainer and/or external filter system clogged. | Clean water supply strainer and/or filter system. |
| | system clogged. Clean water supply strainer and/or filter system. Hot water instead of cold water connected to condenser supply line | See Note 2 and 3. |
| Abnormal amount of steam coming from drain or vent. | Inoperative controls. | See Note 1. |
| | Condenser water supply is turned OFF | Turn ON condenser water supply |
| | Hot water instead of cold water connected to the condenser water line | See Note 2 and 3. |
| | Condenser water line strainer clogged | Clean water supply strainer. See Yearly Maintenance. |
| Food takes too long to cook. To verify the steamers proper operation see Note 8. | Inoperative controls | See Note 1. |
| | Pans too close to the bottom of cabinet. | Put pans in racks near top of cabinet. |
| | Compartment overloaded with too much food. | Put less food into pan. Use fewer pans. |
| | Suggested cooking times are usually listed for cooking at sea level. | Extend cooking times for altitudes above 2500 feet. |
| | Bottom of steamer is scaled. | See Note 7. |
| | Voltage too low for unit. | See Note 5. |
| Easy Timer display has noise/disruptions. | Power surge/not clean power. | Recommended power surge bar to resolve rare EMI/power disruptions. |
| | Easy Timer button does not respond | If EasyTimer display is ON, then the button membrane is broken. |
| If EasyTimer display is OFF then wiring has been damaged. | | See Note 1. |

TROUBLESHOOTING NOTES

1. If the problem is inside the appliance, call a qualified Cleveland Range authorized service representative (Please have the model number and serial number ready when calling.) Cleveland Range will not pay for warranty repairs by unauthorized maintenance and repair centers.
2. Proper installation of the appliance is the responsibility of the Owner-User. Refer to the Warranty.
3. Repairs to external plumbing must be done by a Licensed Plumber.
4. To restart the unit, follow the Lighting (Start-Up) instructions in this manual.
5. Repairs to external wiring must be done by a Licensed Electrician.
6. For more information on products and services, contact your nearest Authorized Sales Representative.
7. For more information on products and services, contact your nearest Authorized Sales Representative. Call the factory for a preventative maintenance program, descaling information, and water treatment systems.
8. Use the Egg Test to evaluate steamer performance.

NOTE: this test is not valid for pressure steamers.

- a) Turn on the steamer and set to MANUAL mode.
- b) Preheat the steamer for ten minutes.
- c) After the compartment is preheated, place a fresh egg on a perforated steam table pan in the middle of the cavity.
- d) Close the door and set the timer as directed by the size chart below:

| Egg Size | Time |
|-------------|------------|
| Medium | 12 minutes |
| Large | 14 minutes |
| Extra Large | 14 minutes |

- e) Carefully remove the egg and place in a container with cold water running over it.
 - f) Let cool under cold running water for 5 minutes.
 - g) After cooling, crack eggshell and peel.
 - h) A properly operating steamer produces a perfect hard-boiled egg.
9. Whenever opening door, especially when water or steam is leaking around the gasket, heed the warning below:

WARNING

Burn, Scald and Equipment Damage Hazard

If the drain is blocked, hot water can fill the cooking compartment and spill out when the cooking compartment door is opened.

Signs of blocked drains include steam or water leaks around the cooking compartment door, and reduced cooking performance.

To help avoid injury:

- Stand on the hinge side and away from the appliance and slowly open the cooking compartment door.
- Inspect the drain(s) before each use and clean them if needed.

Failure to follow these precautions can cause BURNS, SCALDS, and EQUIPMENT DAMAGE.

10. Order replacement descale caps and gaskets from a Cleveland Range authorized maintenance and repair center.

Cleveland

Cleveland Range, LLC
760 Beta Drive, Unit D
Mayfield Village, Ohio 44143
216.481.4900
800.338.2204

Every new piece of Welbilt Foodservice equipment comes with KitchenCare® and you choose the level of service that meets your operational needs from one restaurant to multiple locations

StarCare – Warranty & lifetime service, certified OEM parts, global parts inventory, performance audited

ExtraCare – CareCode, 24/7 Support, online/mobile product information

LifeCare – Install & equipment orientation, planned maintenance, KitchenConnect™, MenuConnect®

Talk with KitchenCare® • 1-844-724-CARE • www.mtwkitchencare.com



To learn how Welbilt Foodservice and its leading brands can equip you, visit our [global web site at www.welbilt.com](http://global.welbilt.com), then discover the regional or local resources available to you.