

## Statement of Responsibilities

This document is for use by experienced and trained Qualified Cleveland Range, LLC Authorized Service Representatives who are familiar with both the safety procedures, and equipment they service.

Cleveland Range, LLC assumes no liability for any death, injury, equipment damage, or property damage resulting from use of, improper use of, or failure to use the information contained in this document.

Cleveland Range, LLC has made every effort to provide accurate information in this document, but cannot guarantee that this document does not contain unintentional errors and omissions.

The information in this document may be subject to technical and technological changes, revisions, or updates.

Cleveland Range, LLC assumes no liability or responsibility regarding errata, changes, revisions, or updates.

Qualified Cleveland Range, LLC Authorized Service Representatives are obligated to follow industry standard safety procedures, including, but not limited to, OSHA regulations, and disconnect / lock out / tag out procedures for all utilities including steam, and disconnect / lock out / tag out procedures for gas, electric, and steam powered equipment and / or appliances

All utilities (gas, electric, water and steam) should be turned OFF to the equipment and locked out of operation according to OSHA approved practices during any servicing of Cleveland Range equipment

Qualified Cleveland Range, LLC Authorized Service Representatives are obligated to maintain up-to-date knowledge, skills, materials and equipment.

## SteamCraft® Ultra 3

COUNTER TYPE DESIGN  
PRESSURELESS CONVECTION STEAMER  
Electric Steam Generator, 8 KW

MODEL:  21-CET-8

ITEM NUMBER \_\_\_\_\_

JOB NAME / NUMBER \_\_\_\_\_

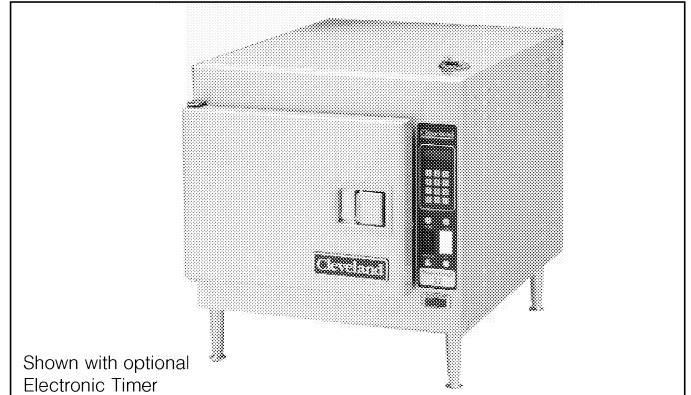
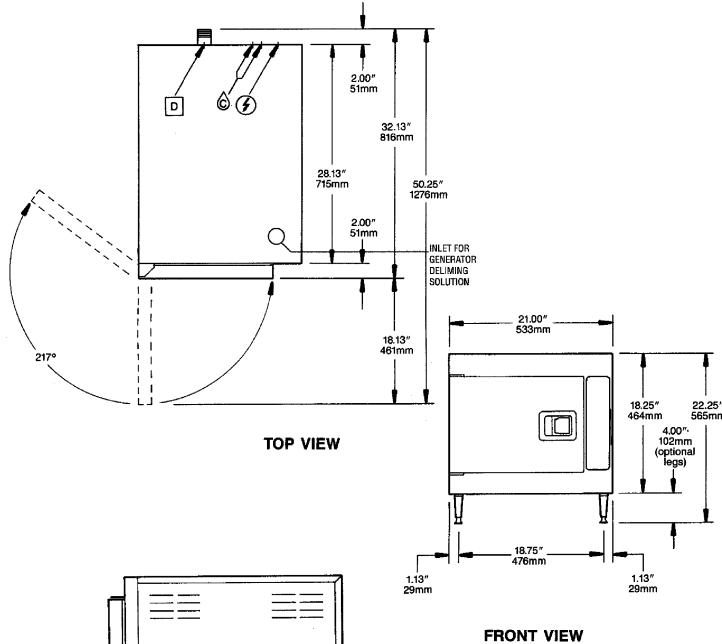

Shown with optional  
Electronic Timer

### SHORT FORM SPECIFICATION

Shall be CLEVELAND, SteamCraft® Ultra 3, one compartment, Counter-Type Steamer, Model 21-CET-8, \_\_\_ volts, 8.5 KW, \_\_\_ Hz. Heavy duty all Stainless Steel construction. Rear mounted, insulated Steam Generator with Remote Probe Type Water Level Controls and Automatic Steam Generator Blowdown with "Water Jet" Drain Cleaning feature.

### WATER QUALITY REQUIREMENT

The recommended minimum water quality standards whether untreated or pre-treated, based upon 10 hours of use per day, and a Daily Blowdown, are as follows:

TOTAL DISSOLVED SOLIDS	less than 60 parts per million
TOTAL ALKALINITY	less than 20 parts per million
SILICA	less than 13 parts per million
pH FACTOR	greater than 7.5
CHLORINE	less than 30 parts per million

Consult a local water treatment specialist for an on site water analysis for recommendations concerning steam generator feed water treatment (if required), in order to remove or reduce harmful concentrations of minerals. The use of highly mineralized water will mean that more frequent servicing of the steam generator will be necessary. The fact that a water supply is potable is not proof that it will be suitable for the generator.

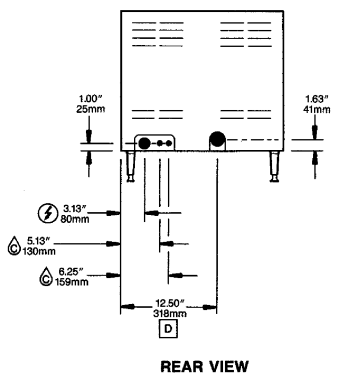
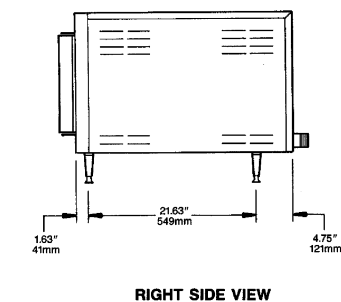

ELECTRIC ⚡				WATER ☉	DRAINAGE □	CLEARANCE
VOLTS	KW	1PH AMPS	3PH AMPS	Cold water: 35 psi minimum 60 psi maximum Two ½" I.D. Tubing: • one for Condenser • one for Steam Generator Unit comes with a 40 Mesh Water Strainer (installation required)	1½" N.P.T. tube Do not connect other units to this drain. Drain line must be vented. No PVC pipe for drain.	Right - 6.00" Left - 3.00" Rear - 3.00"
208	8.5	41	25			
220	8	35	21			
240	9	39	23			
440	8	18	11			
480	9	29	12			

Cleveland Range reserves right of design improvement or modification, as warranted.

CLEVELAND RANGE 21CET8  
SEQUENCE OF OPERATIONS  
Mechanical Timer

1. Supply power is sent to the primary of the main transformer.
  - 115 VAC is sent from the secondary of the main transformer to the on/off rocker,
2. To turn the unit on, depress the red on/off rocker switch.
  - 115 VAC is sent to the red power light.
  - 115 VAC is sent to normally open drain valve closing it.
  - 115 VAC is sent to H and N on the water level board
3. With the water level board energized and no water in the generator
  - 5 seconds later 115 VAC is sent from the FILL terminal to the fill solenoid.
  - The fill solenoid opens and the generator fills through the drain valve.
  - The water fills to the low probe shorting it to ground
  - 115 VAC is sent to the heat standby timer which will energize 3 seconds every 4 minutes to maintain heat while unit is idle
  - 115 VAC is sent from the HEAT terminal to the timed manual switch.
4. When the timed/manual switch is in the timed position and time is on the timer
  - 115 VAC is sent from the timer to the R2 relay coil
    - R2 relay energizes closing the R2A and R2B contacts
    - 115VAC is sent through the now closed R2B contacts to the timer motor
    - 115 VAC is sent through the now closed R2A contacts through the door switch to the normally closed contacts of the high limit switch.
    - 115 VAC is then sent through the high limit to the coil of condensate solenoid
      - The condensate solenoid opens spraying cold water down the compartment drain.
    - 115 VAC is also sent through the high limit to the coil of the contactor.
    - 115 VAC is sent to the clean light timer.
      - When the clean light timer times down 115 VAC is sent to the clean light switch.
      - When the clean light switch is depressed the clean light timer is reset.
5. When the contactor coil is energized supply voltage is sent to both of the elements.
  - The elements are energized and the water is heated to steam.
  - Steam is directed to the cooking compartment.
6. When the timer times out
  - 115 VAC is sent to the 3 second timer and then to the buzzer for 3 seconds.
  - 115 VAC is removed from the R2 relay.
    - R2A contacts open de energizing the heat circuit
    - R22B relay contacts open removing the 115 VAC from the timer motor

7. When the water level reaches the high probe then 115 VAC is removed from the FILL terminal and the fill solenoid is turned off.
8. After the water level drops below the high probe for 5 seconds 115 VAC is sent to the FILL terminal again.
9. The red on/off switch is depressed and the unit is turned off.
  - 115 VAC is removed from the heat and timer circuit.
  - 115 VAC is removed from the normally open drain valve allowing the steamer to drain.
  - 115 VAC is sent to the 3-minute timer and the fill solenoid is energized for 3 minutes flushing the drain.

# STEAMCRAFT 3.1 MECHANICAL TIMER (PROBE)

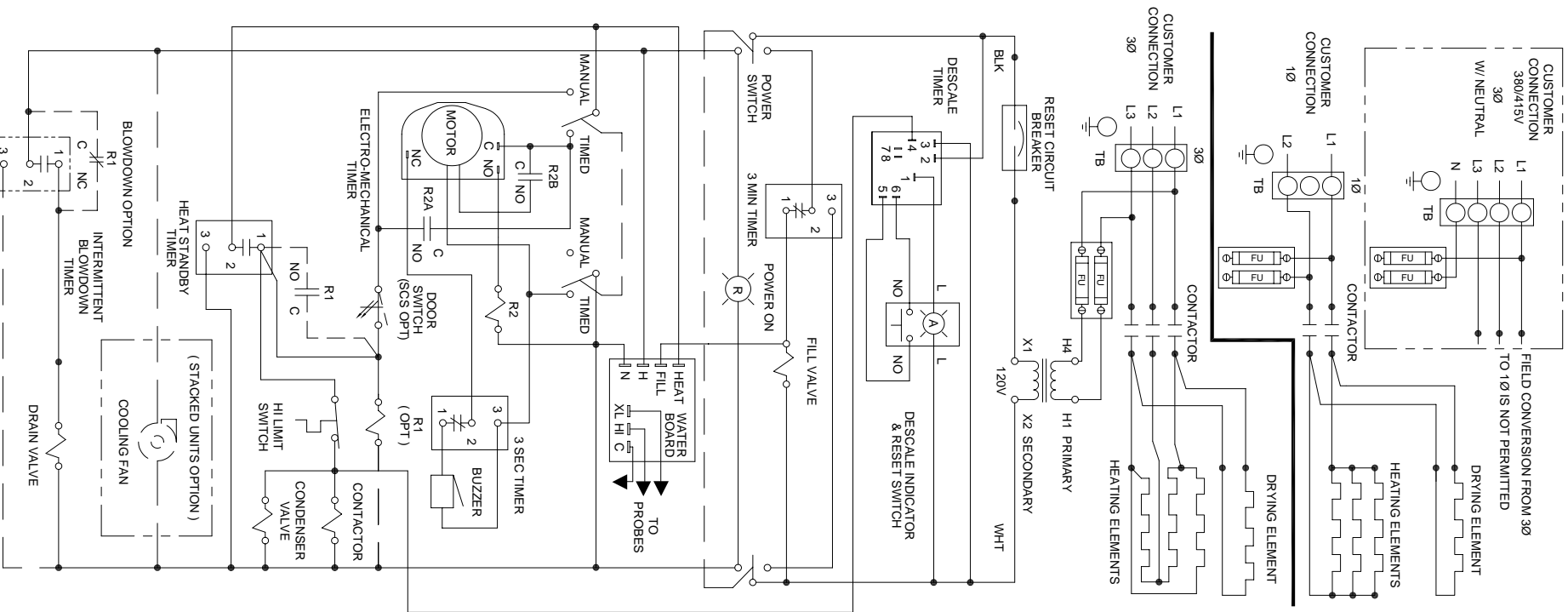

L106347 M

# STEAMCRAFT 3.1 MECHANICAL TIMER (PROBE)

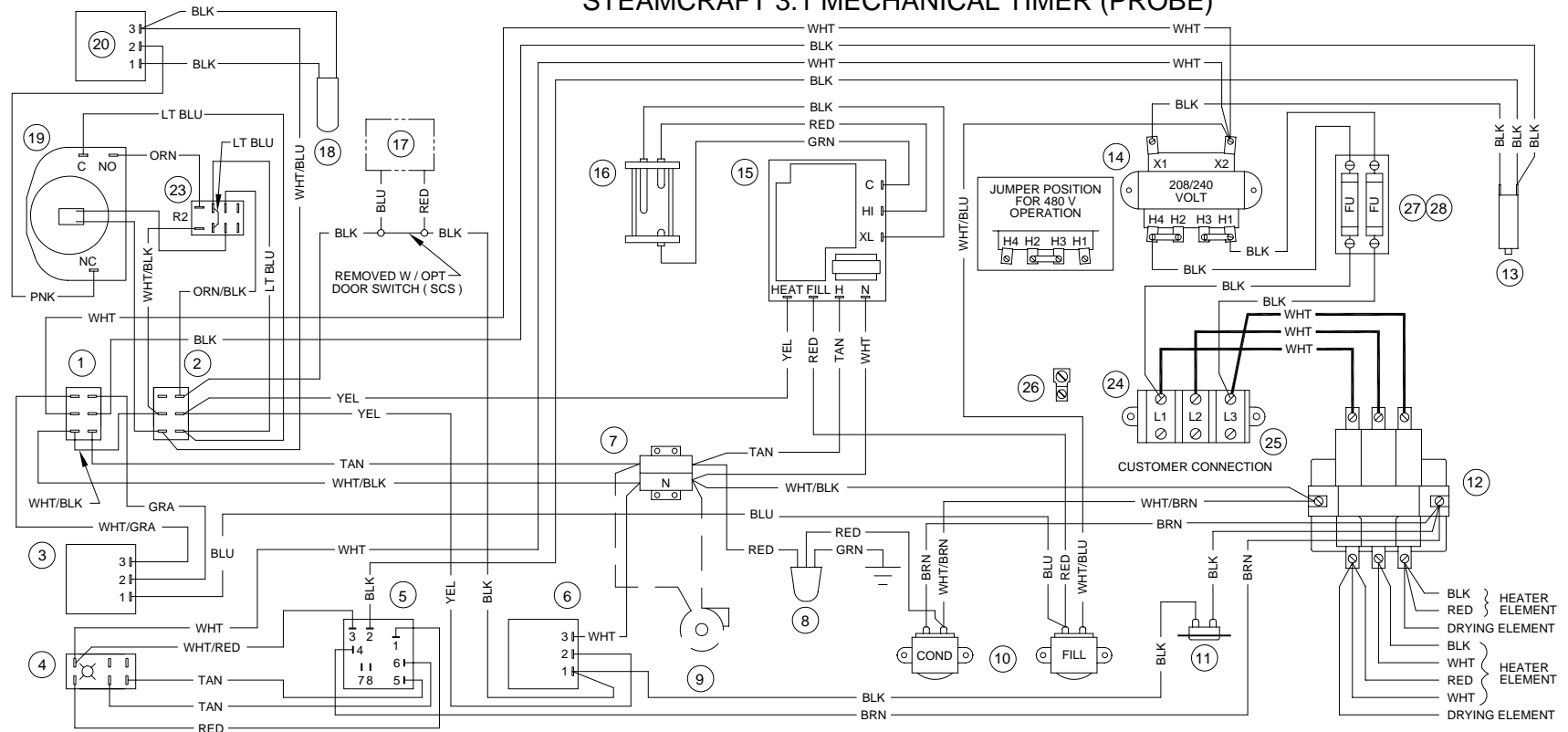

## SINGLE PHASE WIRING CONFIGURATION

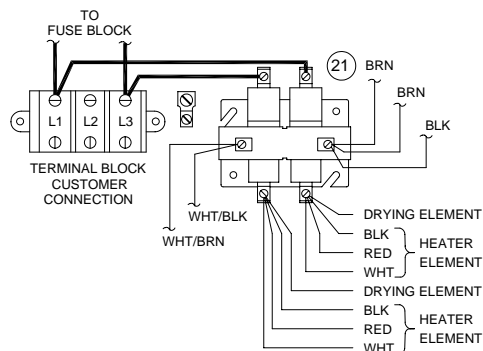

## INTERMITTENT BLOWDOWN OPTION

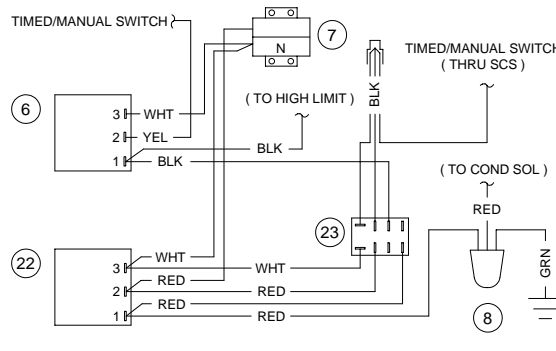

## PARTS LIST:

- |    |                                  |    |                               |
|----|----------------------------------|----|-------------------------------|
| 1  | 19993 - POWER SWITCH             | 17 | 108880 - DOOR SW ( MAGNETIC ) |
| 2  | 104224 - TIMED / MANUAL SW       | 18 | 41350 - BUZZER                |
| 3  | 20478 - 3 MIN TIMER              | 19 | 110198 - MOTORIZED TIMER      |
| 4  | 19994 - DESCALE IND RESET SWITCH | 20 | 20477 - 3 SEC TIMER           |
| 5  | 106911 - DESCALE TIMER           | 21 | 104234 - CONTACTOR            |
| 6  | 109239 - HEAT STANDBY TIMER      | 22 | 106541 - INTMT BLOWDOWN TIMER |
| 7  | 44168 - TERMINAL BLOCK           | 23 | 105966 - RELAY                |
| 8  | 22221 - DRAIN VALVE              | 24 | 101540 - END SEGMENT          |
| 9  | 107211 - COOLING FAN ( OPT )     | 25 | 101541 - TERM BLOCK SECTIONAL |
| 10 | 22218 - WATER SOLENOIDS          | 26 | 20304 - GROUND LUG            |
| 11 | 103731 - HI LIMIT SWITCH         | 27 | 109380 - 3.5 AMP, 600V FUSE   |
| 12 | 300022 - CONTACTOR               | 28 | 109374 - FUSE BLOCK           |
| 13 | 108331 - RESET CIRCUIT BRKR      |    |                               |
| 14 | 20535 - TRANSFORMER              |    |                               |
| 15 | 107241 - WATER BOARD             |    |                               |
| 16 | 107239 - PROBE                   |    |                               |

**CLEVELAND RANGE 21CET8  
SEQUENCE OF OPERATIONS  
Electronic Timer**

1. Supply power is sent to the primary of the main transformer.
  - 115 VAC is sent from the secondary of the main transformer to the on/off rocker
2. To turn the unit on, depress the red on/off rocker switch.
  - 115 VAC is sent to the red indicator light.
  - 115 VAC is sent to normally open drain valve closing it.
  - 115 VAC is sent to H and N on the water level board
  - 115 VAC is sent to the 24VAC transformer for the electronic timer.
  - 115 VAC is sent to the normally open compartment thermostat switch.
3. With the water level board energized and no water in the generator
  - After a 5 second delay, 115 VAC is sent from the FILL terminal to the fill solenoid.
  - The fill solenoid opens and the generator fills through the drain valve.
  - The water fills to the low probe shorting it to ground
  - 115 VAC is sent from the HEAT terminal to the timed manual switch.
  - 115 VAC is sent to the heat standby timer which will energize 3 seconds every 4 minutes to maintain heat while unit is idle
4. When the timed/manual switch is in the timed position and time is on the timer
  - 115 VAC is sent from the timer through the optional door switch to the normally closed contacts of the high limit
  - 115 VAC is then sent through the high limit to the coil of condensate solenoid and the coil of the contactor.
  - 115 VAC is sent to the clean light timer.
  - When the clean light timer times down 115 VAC is sent to the clean light switch.
  - When the clean light switch is depressed the clean light timer is reset.
5. When the contactor is energized supply voltage is sent to both the Steam and Drying elements.
  - Steam is energized and sent to the cooking compartment.
  - When the cooking compartment reaches 193 degrees the compartment thermostat closes sending 115 VAC to the timer.
  - The timer will then begin counting down.
  - When the timer times down a buzzer will sound and the timer will open removing 115 VAC from the heat circuit.
6. When the water level reaches the high probe 115 VAC is removed from the FILL terminal and the fill solenoid is turned off.

7. After the water level drops below the high probe for 5 seconds 115 VAC is sent to the FILL terminal again.
8. The red on/off switch is depressed and the unit is turned off.
  - 115 VAC is removed from the timer and heat circuits.
  - 115 VAC is removed from the normally open drain valve allowing the steamer to drain.
  - 115 VAC is sent to the 3 minute timer and the fill solenoid is energized for 3 minutes flushing the drain.

# STEAMCRAFT 3.1 ELECTRONIC TIMER (PROBE)

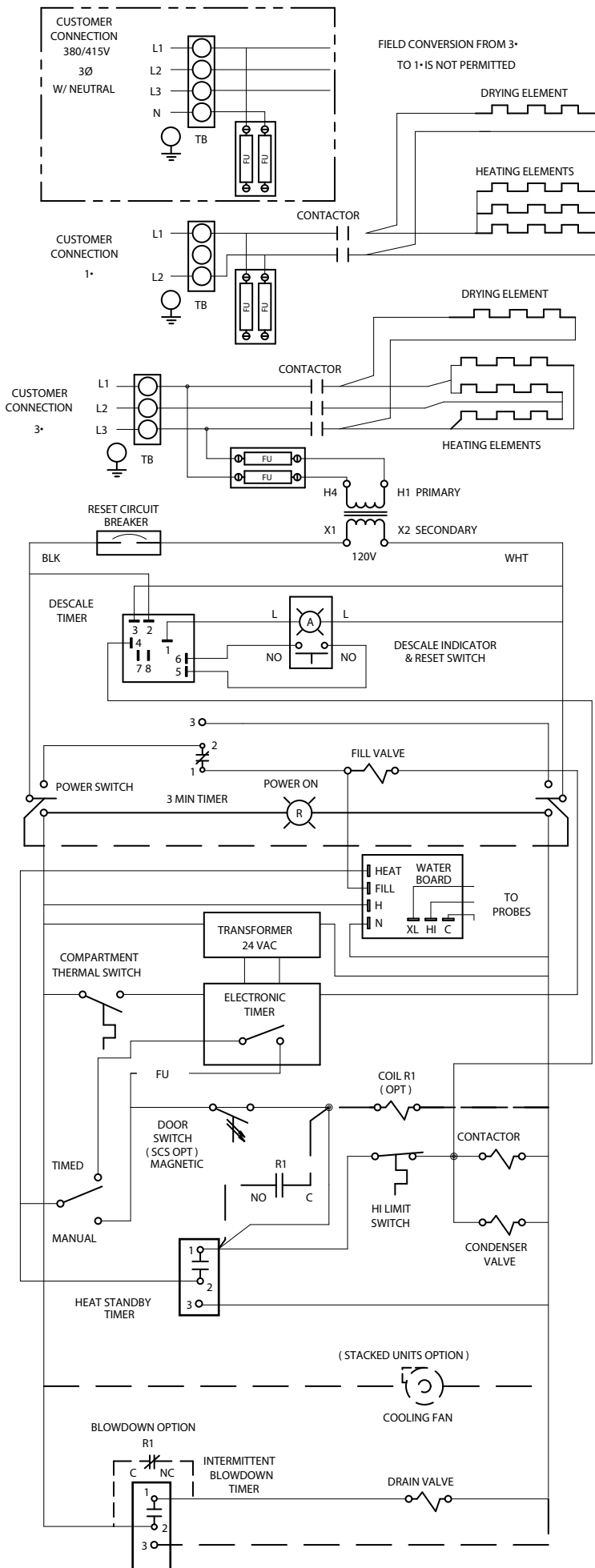

# STEAMCRAFT 3.1 ELECTRONIC TIMER (PROBE)

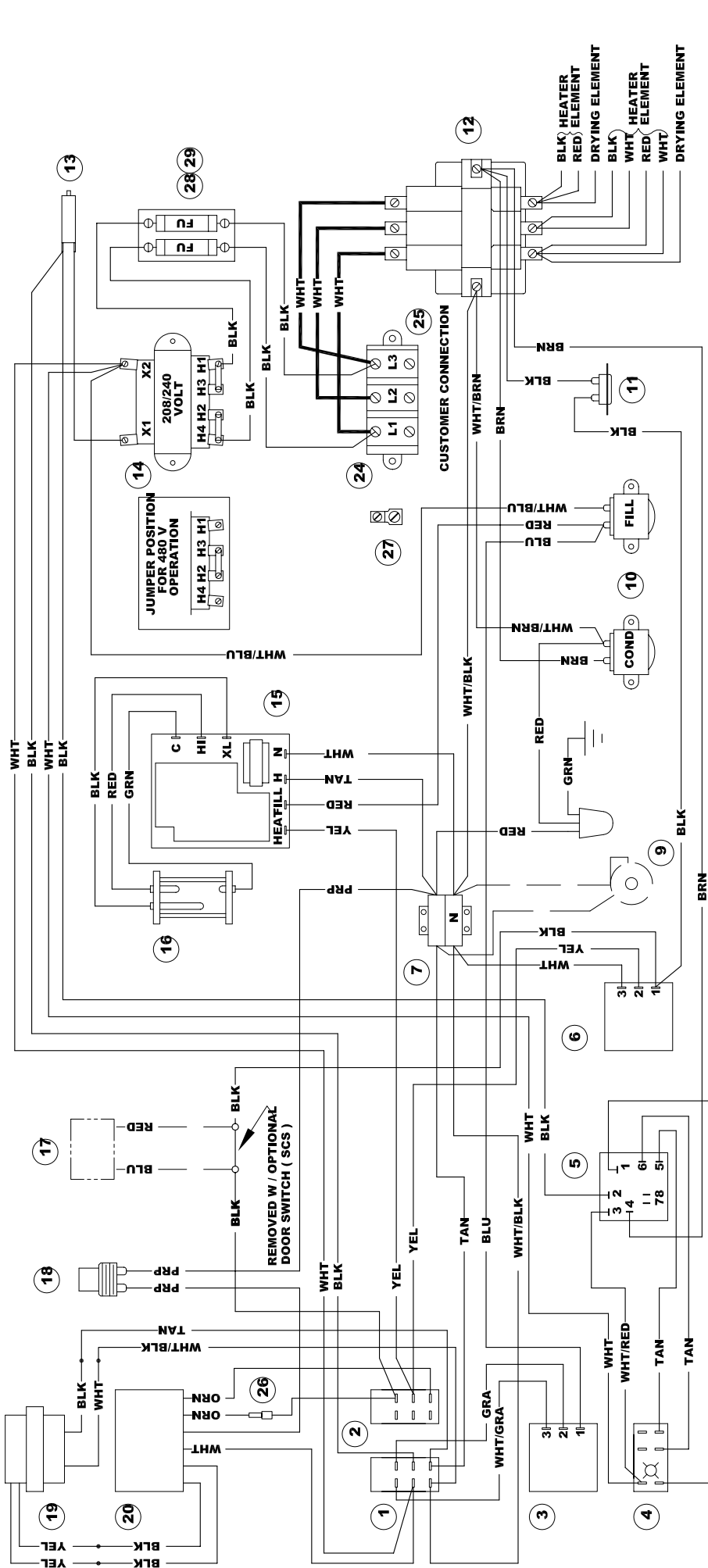

## PARTS LIST

- 1 19993 - POWER SWITCH
- 2 104224 - TIMED / MANUAL SW
- 3 20478 - 3 MIN TIMER
- 4 19994 - DESCALE IND RESET SW
- 5 106911 - DESCALE TIMER
- 6 109239 - HEAT STANDBY TIMER
- 7 44168 - TERMINAL BLOCK
- 8 22221 - DRAIN VALVE
- 9 107211 - COOLING FAN ( OPT )
- 10 102218 - WATER SOLENOIDS
- 11 1103731 - HI LIMIT SWITCH
- 12 1230022 - CONTACTOR
- 13 13108331 - RESET CIRCUIT BRKR
- 14 1420535 - TRANSFORMER
- 15 107241 - WATER BOARD
- 16 107239 - PROBE
- 17 108880 - DOOR SW ( SCS ) MAGN
- 18 19972 - COMP THERMAL SW
- 19 104390 - TRANSFORMER
- 20 104389 - ELECTRONIC TIMER
- 21 104234 - CONTACTOR
- 22 106541 - INTMT BLOWDOWN TIMER
- 23 105966 - RELAY
- 24 101540 - END SEGMENT
- 25 101541 - TERM BLOCK SECTIONAL
- 26 106909 - 2 AMP, 250V FUSE
- 27 20304 - GROUND LUG
- 28 109380 - 3.5 AMP, 600V FUSE
- 29 109374 - FUSE BLOCK

## INTERMITTENT BLOWDOWN OPTION

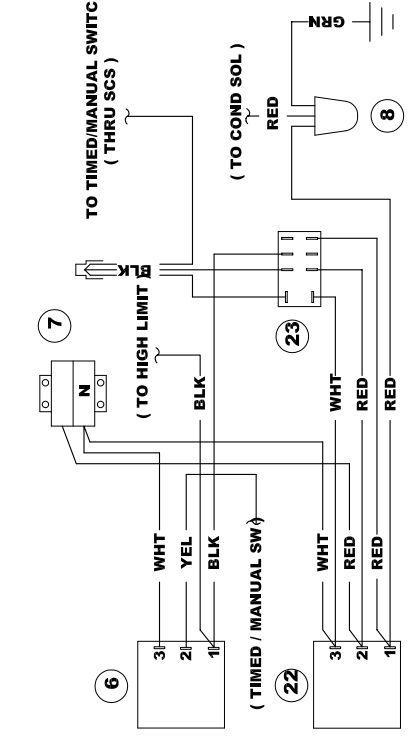

## SINGLE PHASE WIRING CONFIGURATION

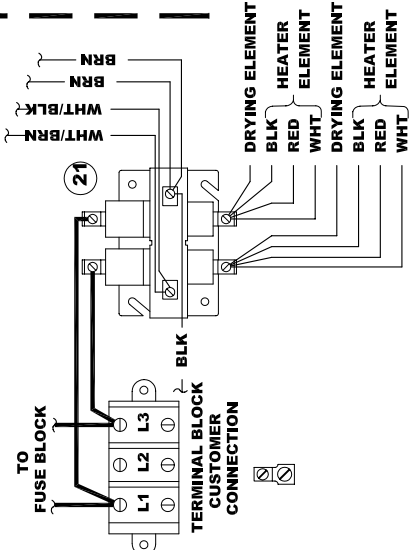

**PROBLEM:**  
**21CET8**  
**21CET16**  
**21CEA10**  
**Steamer won't steam.**

**Steamer won't steam**

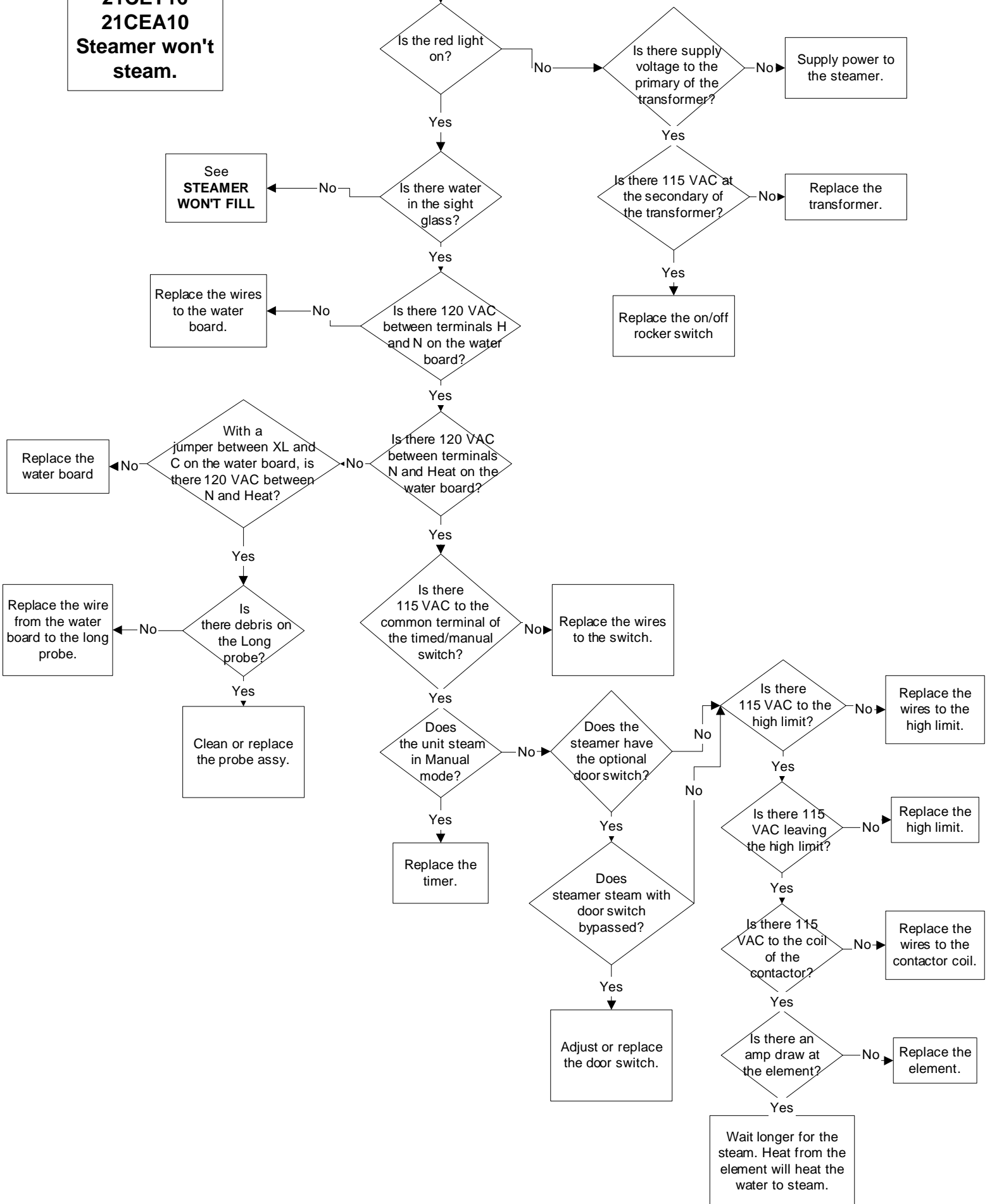

**PROBLEM:**  
**21CET8**  
**21CET16**  
**24CEA10**  
**Steamer wont fill**

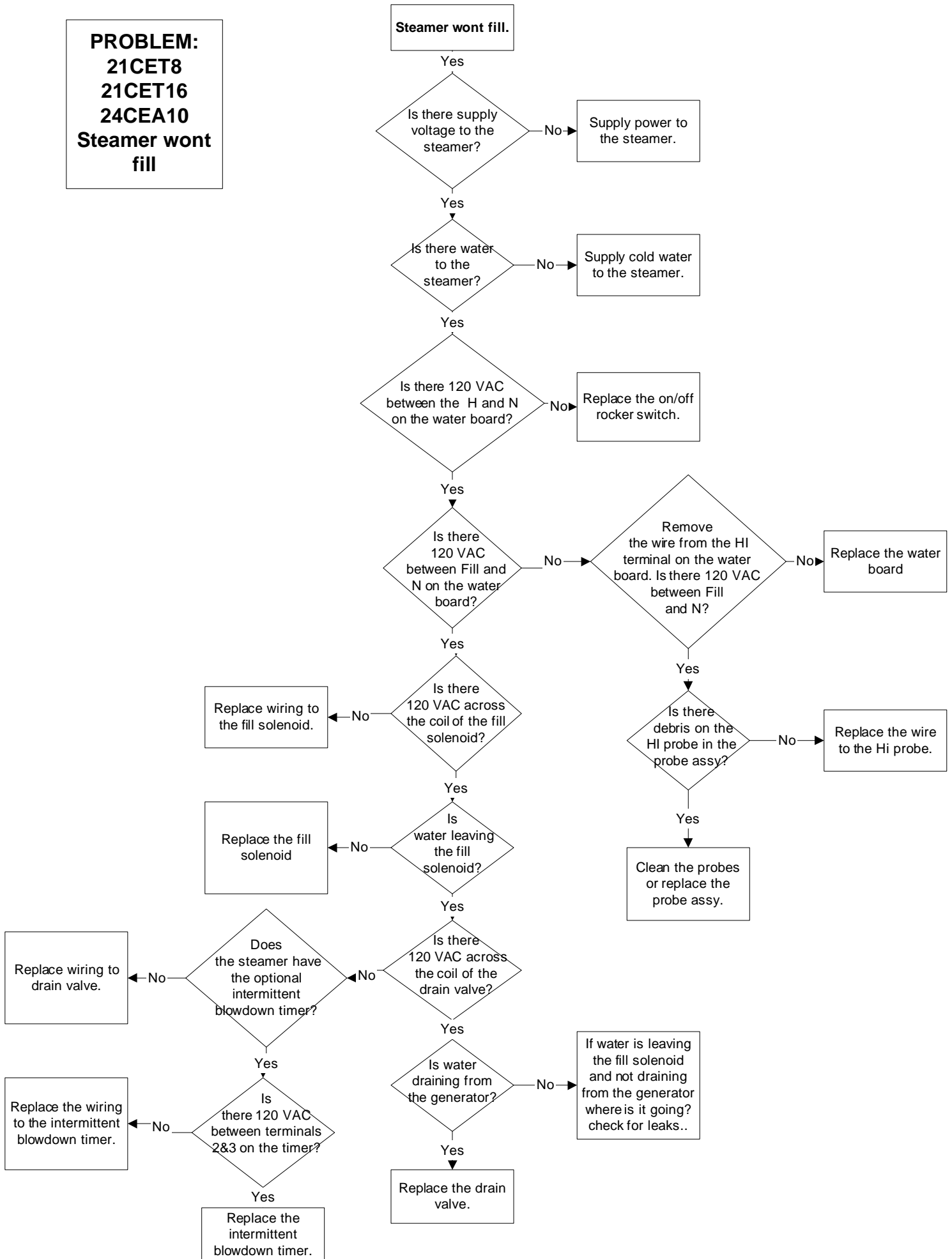

**PROBLEM:**  
**21CET8, 21CET16, 24CEA10**  
**Electronic timer displays "PAUS" and won't count down**

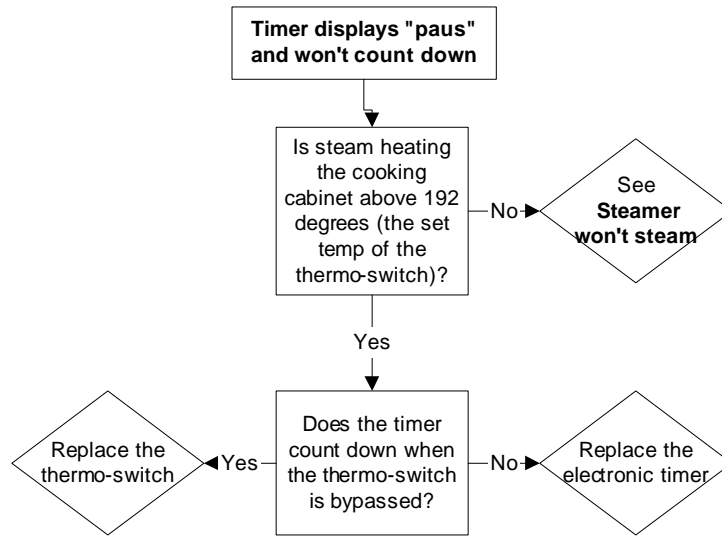

**PROBLEM:**  
**21CET8, 21CET16, 24CEA10**  
**Steam leaks around the door.**

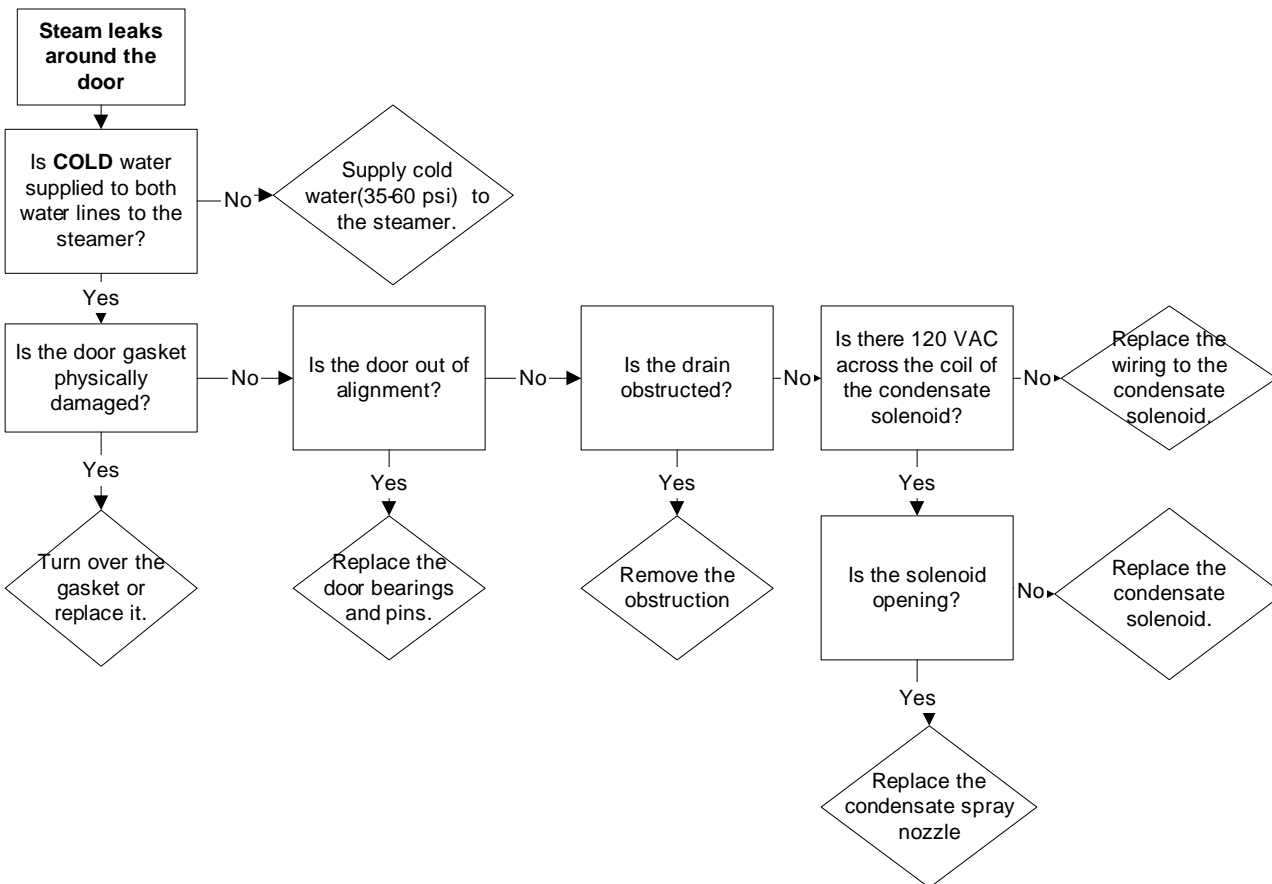

**PROBLEM:  
21CET8  
21CET16  
24CEA10  
Steamer overfills.  
(Water sprays into cooking cabinet)**

**Steamer overfills  
(Water sprays into the cooking cabinet)**

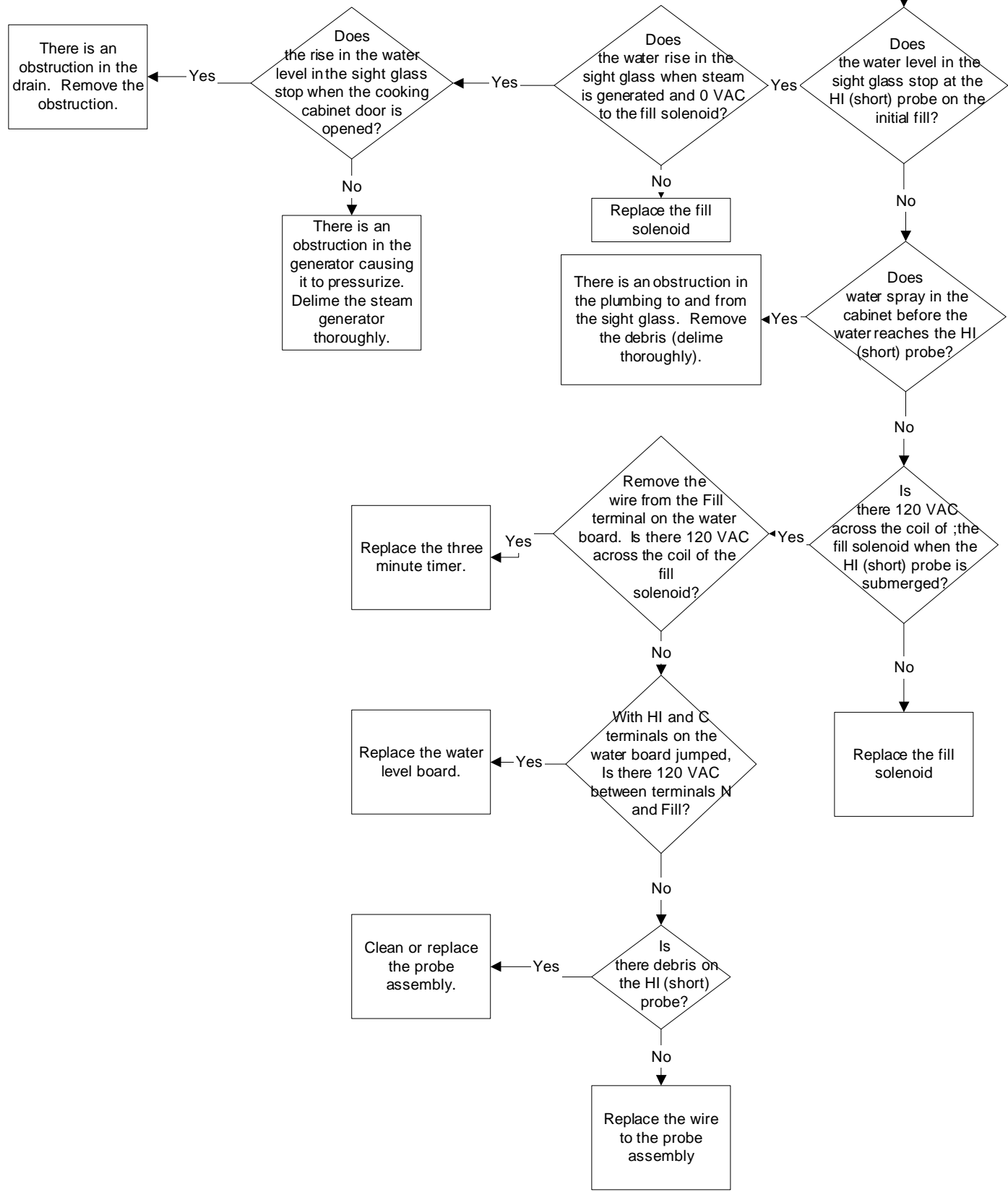

**PROBLEM:  
21CET8  
21CET16  
24CEA10  
Steamer won't stop steaming with  
door open**

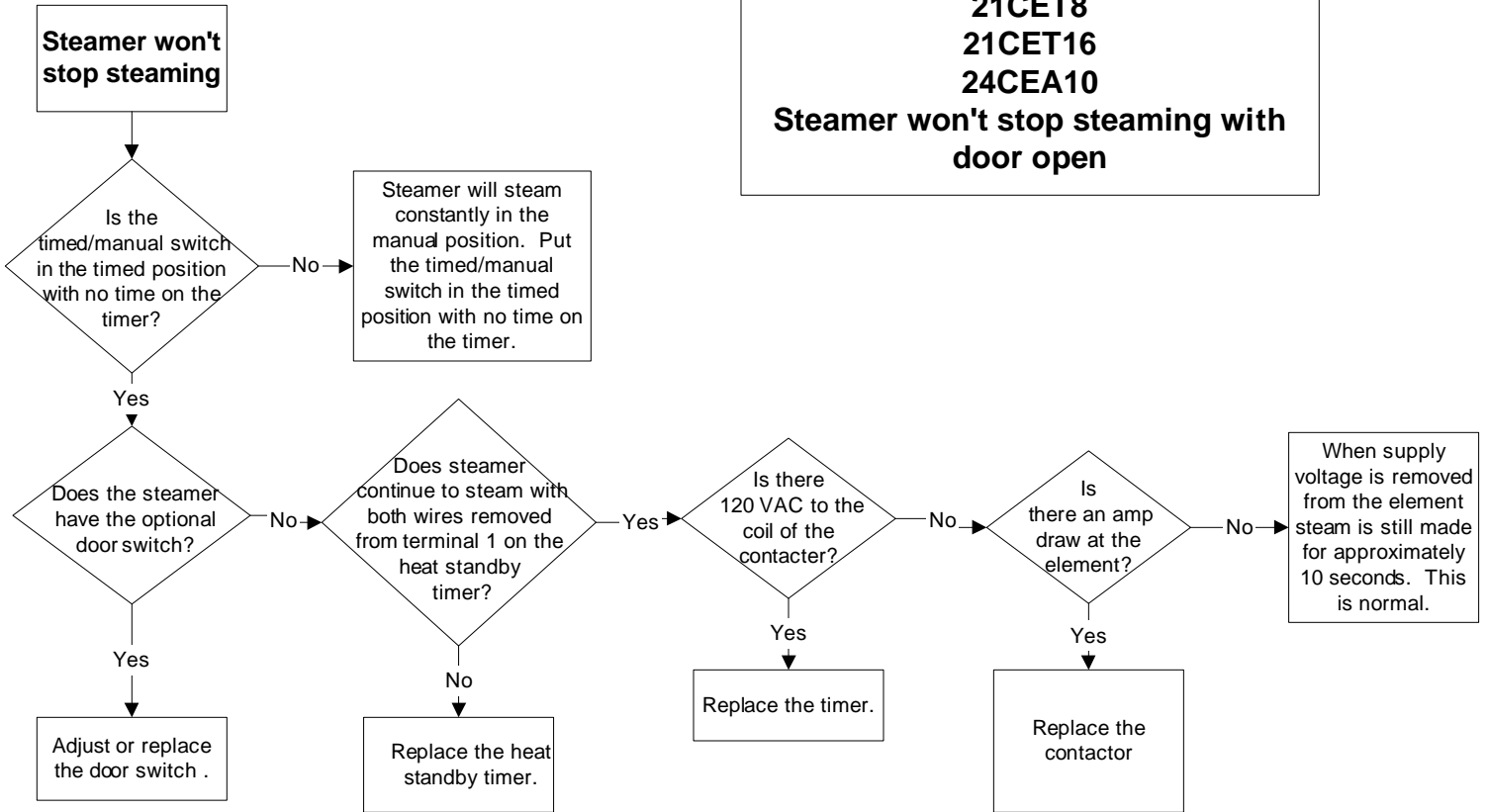

**Problem:  
21CET8, 24CEA10  
Steamer won't preheat**

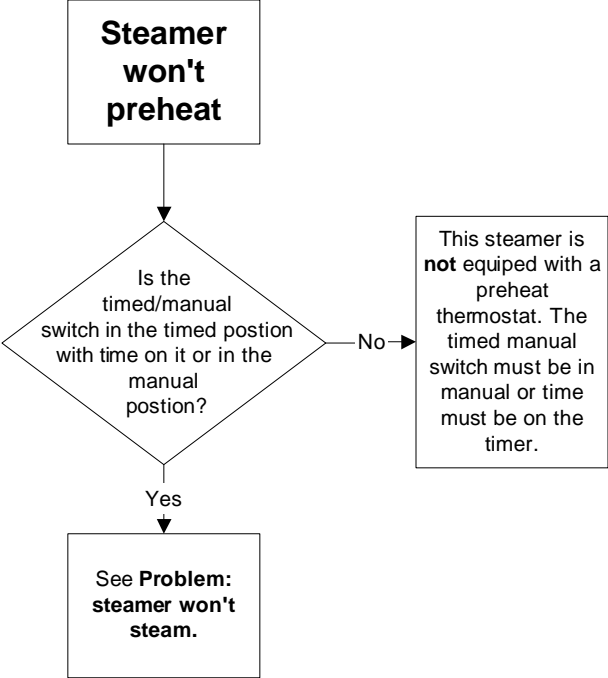

**Problem:  
21CET16  
Steamer won't preheat**

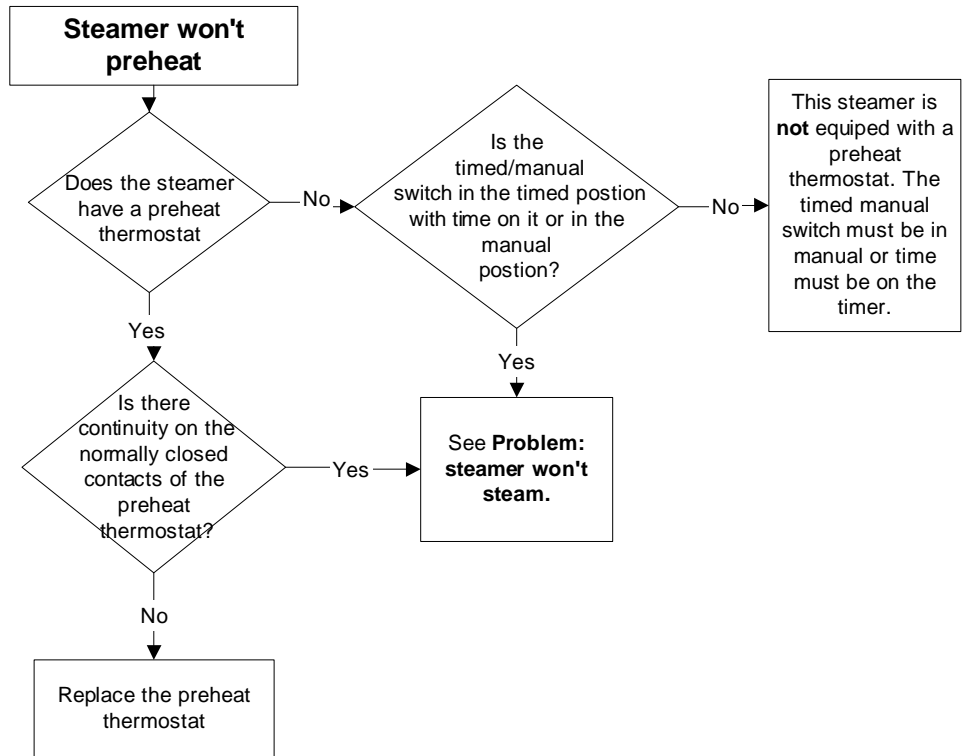

## SteamCraft® Ultra 3 Stacked

TWO COMPARTMENT  
TWIN ELECTRIC STEAM GENERATOR  
8 KW EACH

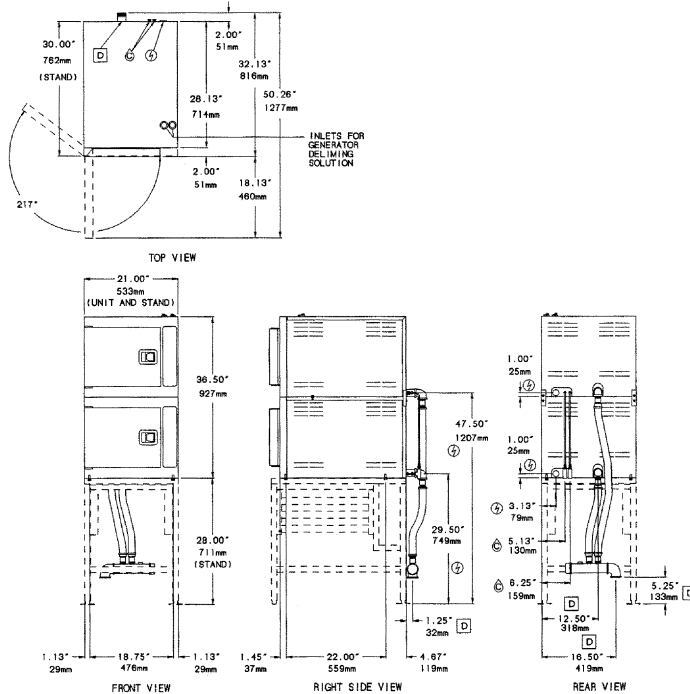

MODEL:  (2)21-CET-8

ITEM NUMBER \_\_\_\_\_

JOB NAME / NUMBER \_\_\_\_\_

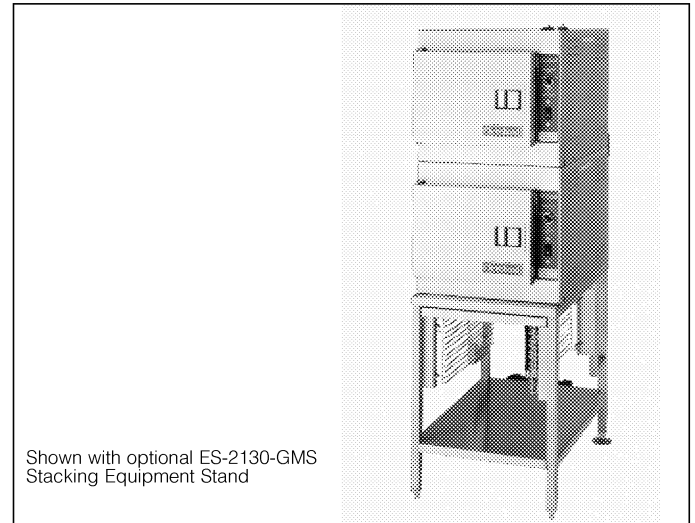

Shown with optional ES-2130-GMS Stacking Equipment Stand

### SHORT FORM SPECIFICATION

Shall be CLEVELAND, Two compartment, SteamCraft® Ultra 3 Stacked, Floor model steamer, Model (2)21-CET-8, \_\_\_\_\_ Volts, \_\_\_\_\_ Phase. 60 minute mechanical timer, Steam Standby mode. Heavy duty all stainless steel construction. Rear mounted, insulated steam generator with Remote Probe Type Water Level Controls and Automatic Steam Generator. Blowdown with "Water Jet" drain cleaning feature.

**\*Note:** The diagrams above are shown with the model 2-21-CET-8-GMS mounted on the optional ES-2130-GMS Staclomg Equipment Stand.

ELECTRIC ⚡ ⚡				WATER 💧	DRAINAGE <input type="checkbox"/>	CLEARANCE
Two separate electrical connections are required				Cold water: 35 psi minimum 60 psi maximum  Two 1/4" I.D. Tubing: • one for Condenser • one for Steam Generator  Unit comes with a 40 Mesh Water Strainer (installation required)	1 1/2" Dia.  Do not connect any other units to this drain.  Drain line must be vented.  No PVC pipe for drain.	Right - 12.00" Left - 3.00" Rear - 3.00"
VOLTAGE	KW each / total	1PH AMPS each / total	3PH AMPS each / total			
208	8.5 / 17	41 / 82	25 / 50			
220	8.0 / 16	35 / 70	21 / 42			
240	9.0 / 18	39 / 78	23 / 46			
440	8.0 / 16	18 / 36	11 / 22			
480	9.0 / 18	29 / 58	12 / 24			

Cleveland Range reserves right of design improvement or modification, as warranted.

### WATER QUALITY REQUIREMENT

The recommended minimum water quality standards whether untreated or pre-treated, based upon 10 hours of use per day, and a daily Blowdown, are as follows:

TOTAL DISSOLVED SOLIDS	less than 60 parts per million
TOTAL ALKALINITY	less than 20 parts per million
SILICA	less than 13 parts per million
pH FACTOR	greater than 7.5

Consult a local water treatment specialist for an on-site water analysis for recommendations concerning steam generator feed water treatment (if required), in order to remove or reduce harmful concentrations of minerals.

# STEAMCRAFT 3.1 MECHANICAL TIMER (FLOAT)

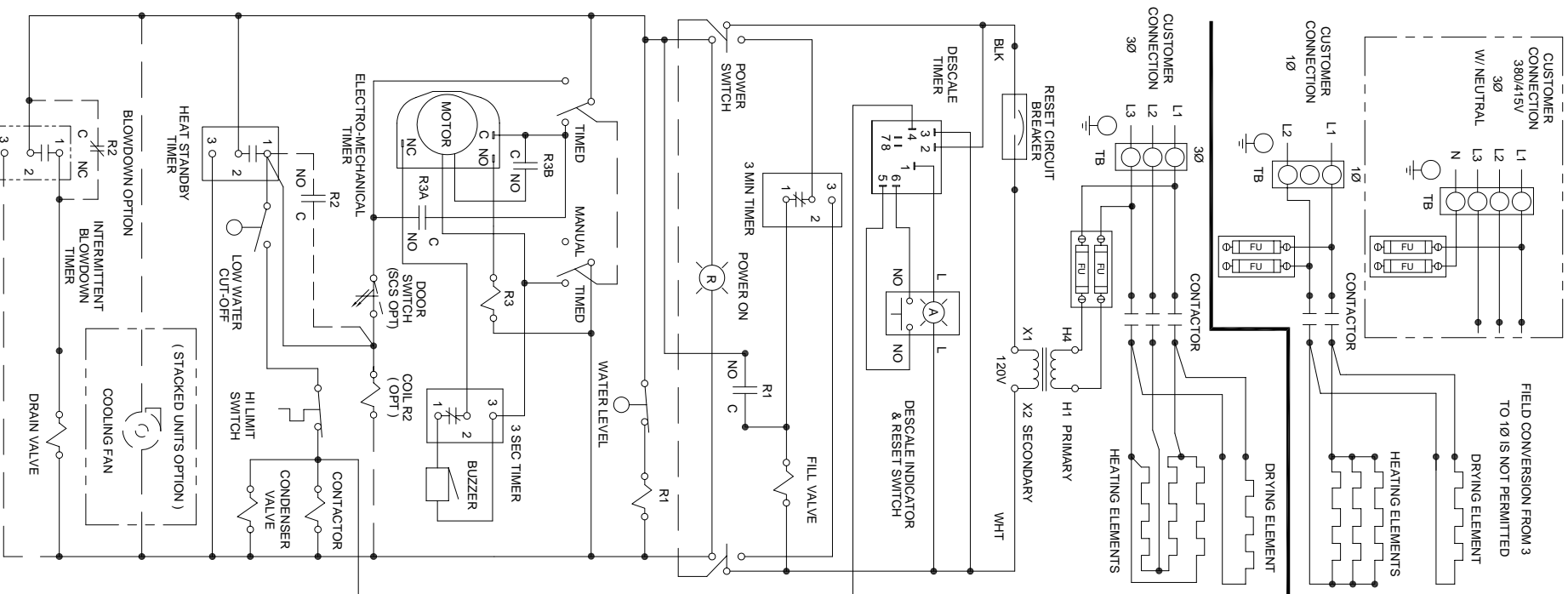

L300163 D

# STEAMCRAFT 3.1 MECHANICAL TIMER ( FLOAT )

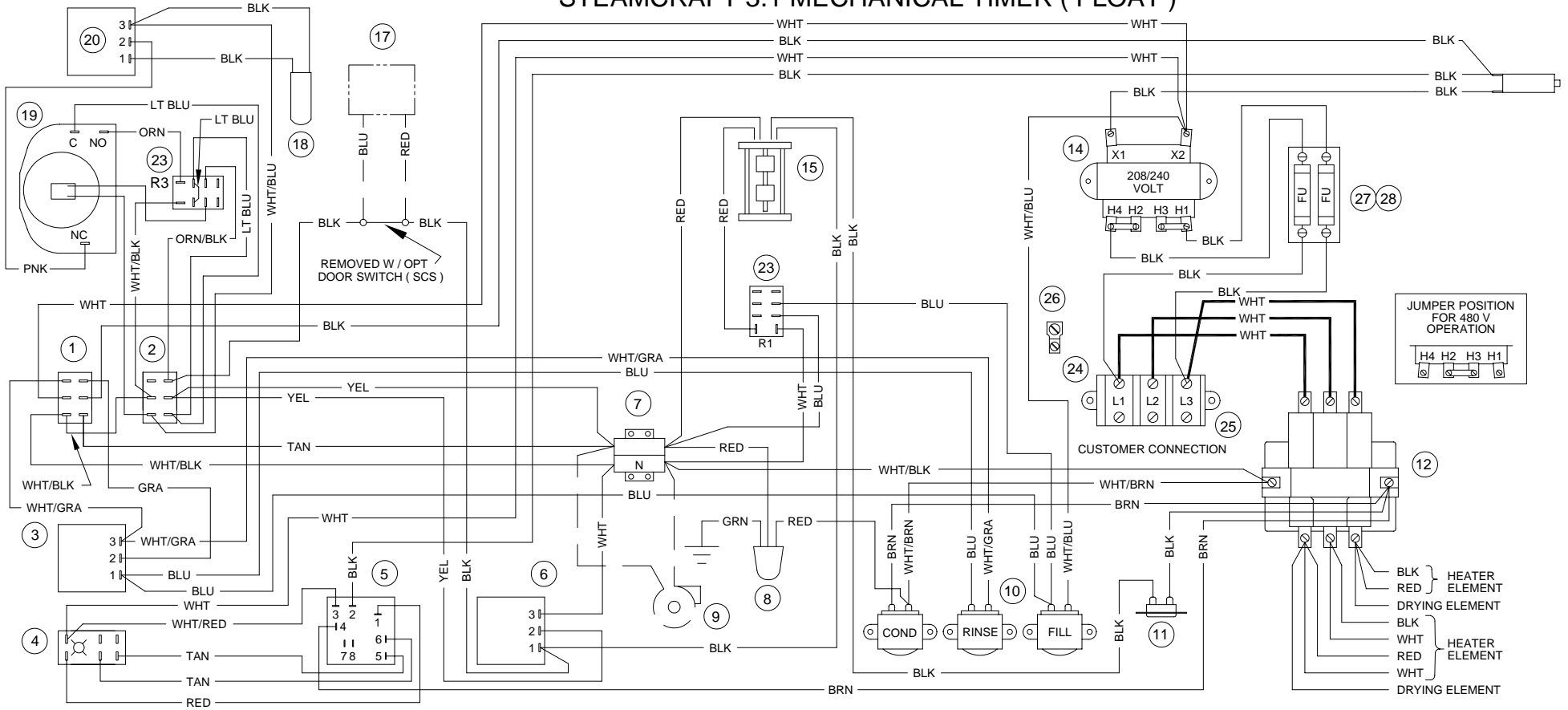

## SINGLE PHASE WIRING CONFIGURATION

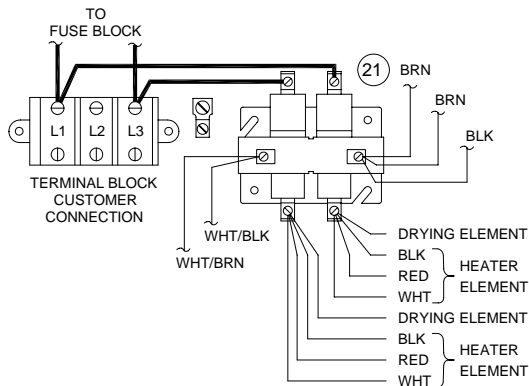

## INTERMITTENT BLOWDOWN OPTION

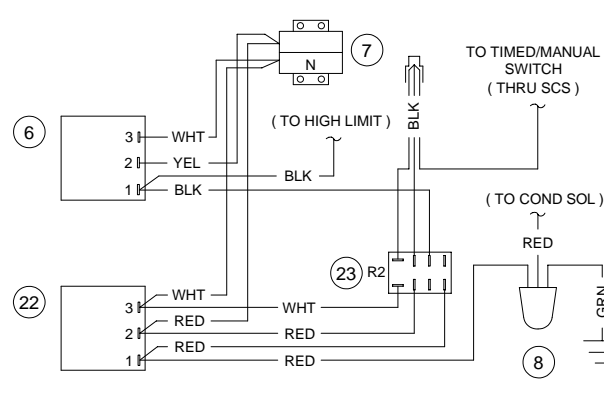

## PARTS LIST:

- |    |                                  |    |                               |
|----|----------------------------------|----|-------------------------------|
| 1  | 19993 - POWER SWITCH             | 17 | 108880 - DOOR SW ( MAGNETIC ) |
| 2  | 104224 - TIMED / MANUAL SW       | 18 | 41350 - BUZZER                |
| 3  | 20478 - 3 MIN TIMER              | 19 | 110198 - MOTORIZED TIMER      |
| 4  | 19994 - DESCALE IND RESET SWITCH | 20 | 20477 - 3 SEC TIMER           |
| 5  | 106911 - DESCALE TIMER           | 21 | 104234 - CONTACTOR            |
| 6  | 109239 - HEAT STANDBY TIMER      | 22 | 106541 - INTMT BLOWDOWN TIMER |
| 7  | 44168 - TERMINAL BLOCK           | 23 | 105966 - RELAY                |
| 8  | 22221 - DRAIN VALVE              | 24 | 101540 - END SEGMENT          |
| 9  | 107211 - COOLING FAN ( OPT )     | 25 | 101541 - TERM BLOCK SECTIONAL |
| 10 | 22218 - WATER SOLENOIDS          | 26 | 20304 - GROUND LUG            |
| 11 | 103731 - HI LIMIT SWITCH         | 27 | 109374 - FUSE BLOCK           |
| 12 | 300022 - CONTACTOR               | 28 | 109380 - FUSE 3.5A 600V       |
| 13 | 108331 - RESET CIRCUIT BRKR      |    |                               |
| 14 | 20535 - TRANSFORMER              |    |                               |
| 15 | 103726 - FLOAT                   |    |                               |
| 16 | -                                |    |                               |

# RELAY CONTROLLED FILL VALVE ( W/ FLOAT )

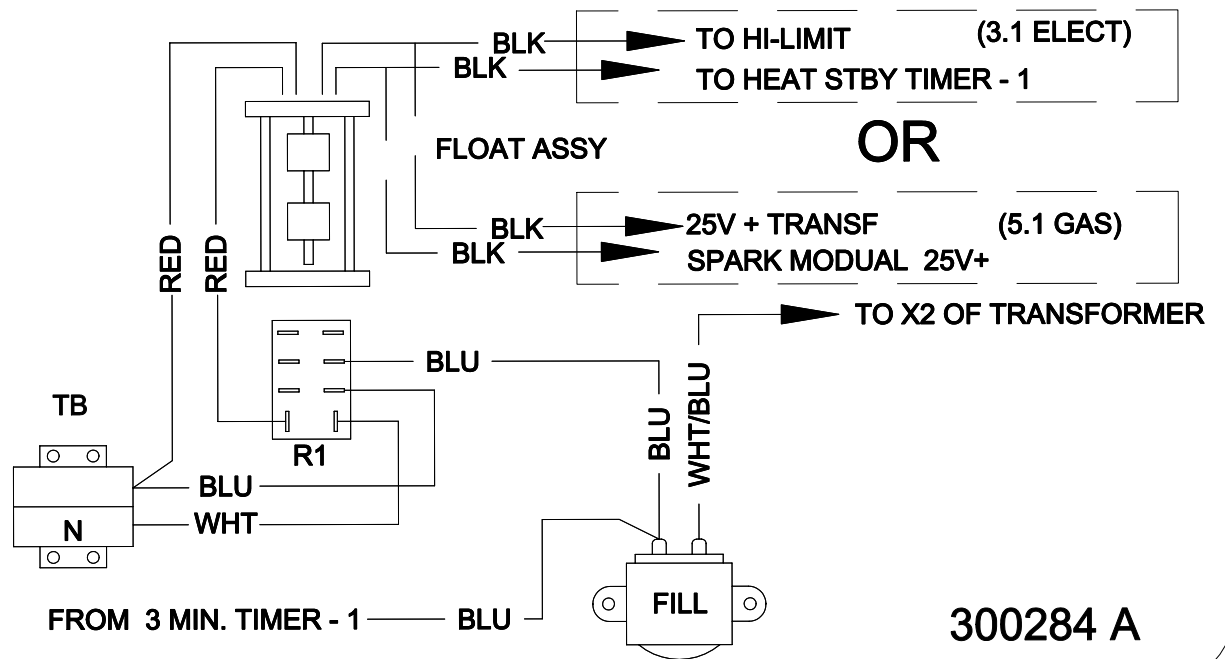
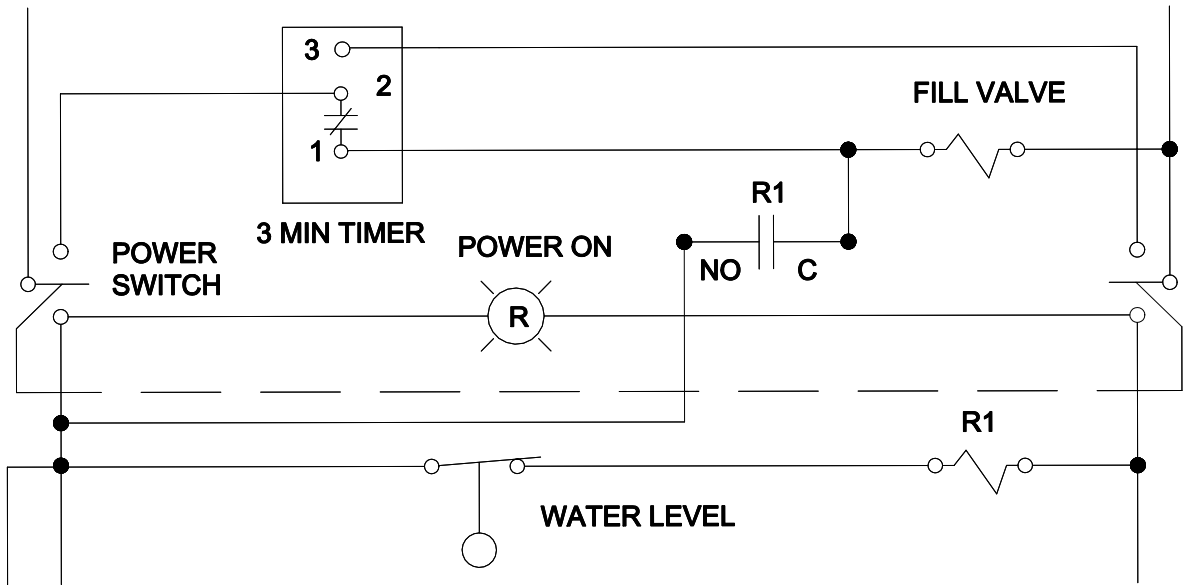

300284 A

PART NUMBER : **FK300284**



# STEAMCRAFT 3.1 ON/OFF SWITCH (PROBE)

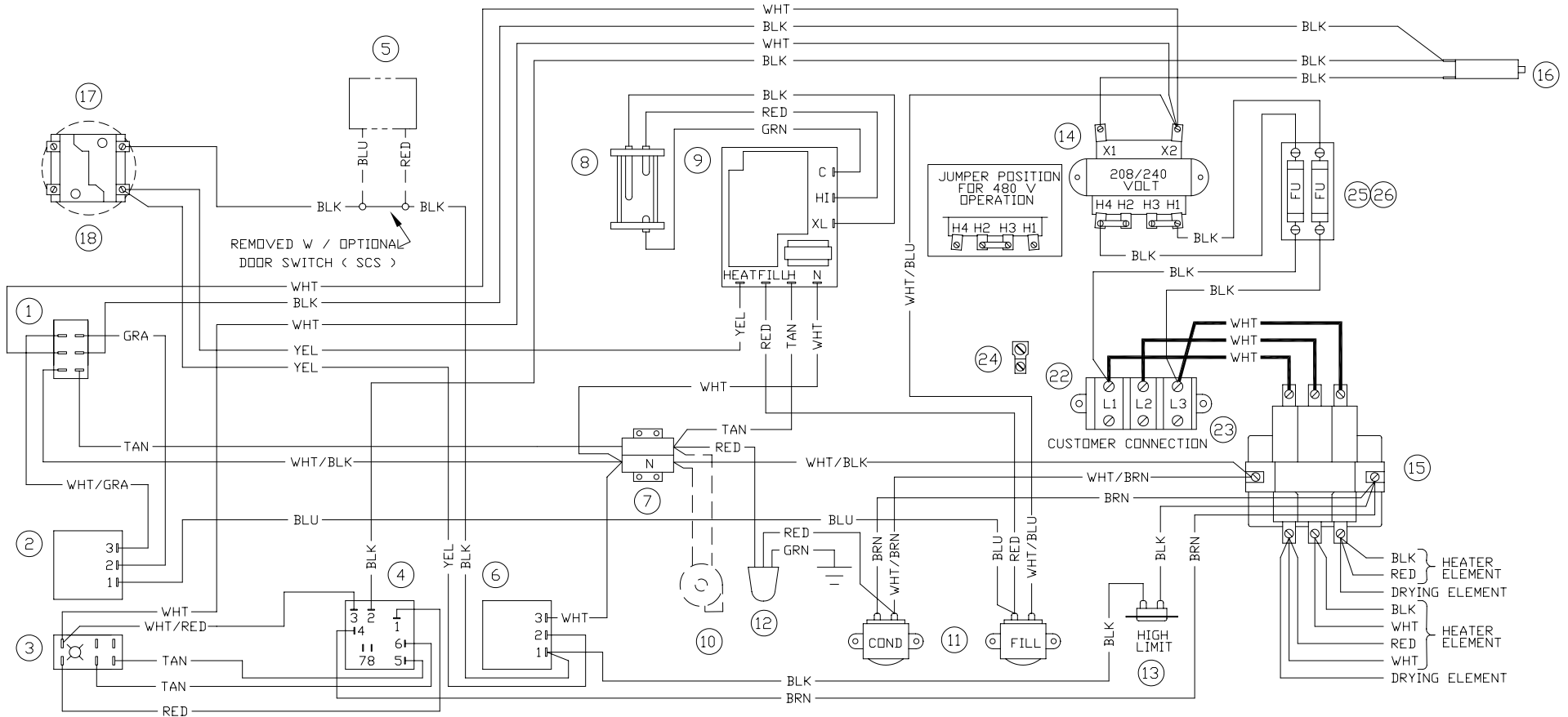

SINGLE PHASE WIRING CONFIGURATION

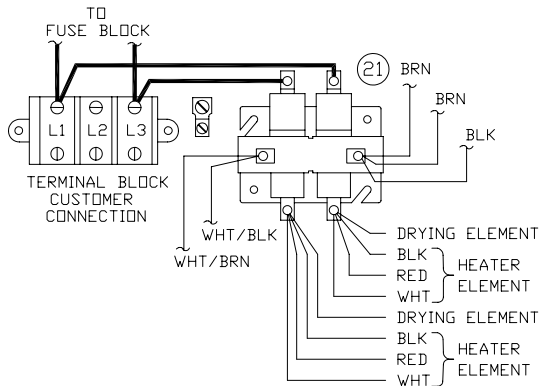

INTERMITTENT BLOWDOWN OPTION

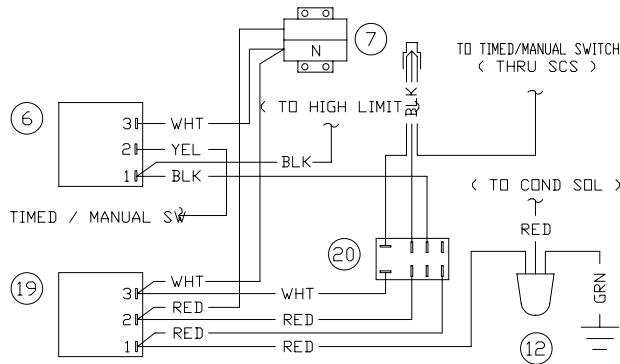

## PARTS LIST

- |                                     |                                  |
|-------------------------------------|----------------------------------|
| 1 19993 - POWER SWITCH              | 17 102534 - ON / OFF SWITCH      |
| 2 20478 - 3 MIN TIMER               | 18 102533 - CONTACT BLOCK        |
| 3 19994 - DESCALE IND RESET SWITCH  | 19 106541 - INTMT BLOWDOWN TIMER |
| 4 106911 - DESCALE TIMER            | 20 105966 - RELAY                |
| 5 108880 - DDDR SW ( SCS ) MAGNETIC | 21 104234 - CONTACTOR            |
| 6 109239 - HEAT STANDBY TIMER       | 22 101540 - END SEGMENT          |
| 7 44168 - TERMINAL BLOCK            | 23 101541 - TERM BLOCK SECTIONAL |
| 8 107239 - PROBE                    | 24 20304 - GROUND LUG            |
| 9 107241 - WATERBOARD               | 25 109380 - 3.5 AMP, 600V FUSE   |
| 10 107211 - COOLING FAN ( OPT )     | 26 109374 - FUSE BLOCK           |
| 11 22218 - WATER SOLENOID           |                                  |
| 12 22221 - DRAIN VALVE              |                                  |
| 13 103731 - HI LIMIT SWITCH         |                                  |
| 14 20535 - TRANSFORMER              |                                  |
| 15 300022 - CONTACTOR               |                                  |
| 16 108331 - RESET CIRCUIT BRKR      |                                  |



# Cleveland

## Descaling Procedure-SteamCraft Ultra and Gemini Series

### How Much DISSOLVE to Use

Model	Dissolve
Ultra 3	1/2 Gallon
Ultra 5	1 Gallon
Ultra 10 (Elec.)	1 Gallon (ea.)
Ultra 10 (Gas)	1½ Gallon
Gemini 6 & 10	1 Gallon (ea.)

#### 1. Turn the unit OFF and open the doors:

This will drain and rinse the generator for about 3 minutes.

#### 2. Turn the unit power back On:

The generator will begin to refill with water.

#### 3. Select Timed with the Timed/Manual switch:

DO NOT start the timer, since you do not want to heat the water during descaling. Leave the doors open.

#### 4. Remove descaling port cap and add with the specified amount of DISSOLVE: (See chart above)

Do this while the unit is refilling. The generators can take-up to 8 minutes to refill.

#### 5. After refill has stopped, add extra tap water into the descaling port until liquid is seen entering the cooking cabinet. Note: Ultra 10 gas will have liquid coming out of the drain,

Adding extra water when descaling will raise the descaling solution higher than the normal fill level, allowing the DISSOLVE to work on sensors and surfaces above the water line

Note: Some SteamCraft Ultra models (the electric powered Ultra 10 and Gemini 6 and 10, for example) have two generators and two descaling ports. Both units should be descaled at the same time, using this procedure

#### 6. Let the descaler soak in generator for approximately one hour:

#### 7. After one hour, turn the unit power Off: This will drain and rinse the generator for about 3 minutes.



#### 8. After the 3-minute drain cycle completes, turn the unit back ON. After the filling has stopped, add water until liquid enters the cooking compartment (or drain for the ultra 10 gas), and then turn the unit OFF. This will drain and flush any residue from the water level control assembly. Replace descaling cap.

#### 9. After the 3 minute drain cycle completes, Turn the unit ON and set the Timer for 20 minutes: Make sure the Time/Manual switch is in the timed setting and the doors are closed.

#### 10. When the timer times out (after 20 minutes) turn the power Off:

This will drain and rinse the generator for about 3 minutes.

This ends the descaling procedure. You can now turn the unit back on and resume normal startup and cooking operations.