

Statement of Responsibilities

This document is for use by experienced and trained Qualified Cleveland Range, LLC Authorized Service Representatives who are familiar with both the safety procedures, and equipment they service.

Cleveland Range, LLC assumes no liability for any death, injury, equipment damage, or property damage resulting from use of, improper use of, or failure to use the information contained in this document.

Cleveland Range, LLC has made every effort to provide accurate information in this document, but cannot guarantee that this document does not contain unintentional errors and omissions.

The information in this document may be subject to technical and technological changes, revisions, or updates.

Cleveland Range, LLC assumes no liability or responsibility regarding errata, changes, revisions, or updates.

Qualified Cleveland Range, LLC Authorized Service Representatives are obligated to follow industry standard safety procedures, including, but not limited to, OSHA regulations, and disconnect / lock out / tag out procedures for all utilities including steam, and disconnect / lock out / tag out procedures for gas, electric, and steam powered equipment and / or appliances

All utilities (gas, electric, water and steam) should be turned OFF to the equipment and locked out of operation according to OSHA approved practices during any servicing of Cleveland Range equipment

Qualified Cleveland Range, LLC Authorized Service Representatives are obligated to maintain up-to-date knowledge, skills, materials and equipment.

SteamCraft® Ultra 5

COUNTER TYPE PRESSURELESS
CONVECTION STEAMER
GAS Steam Generator, 75,000 BTU

MODEL: 21-CGA-5

ITEM NUMBER _____

JOB NAME / NUMBER _____

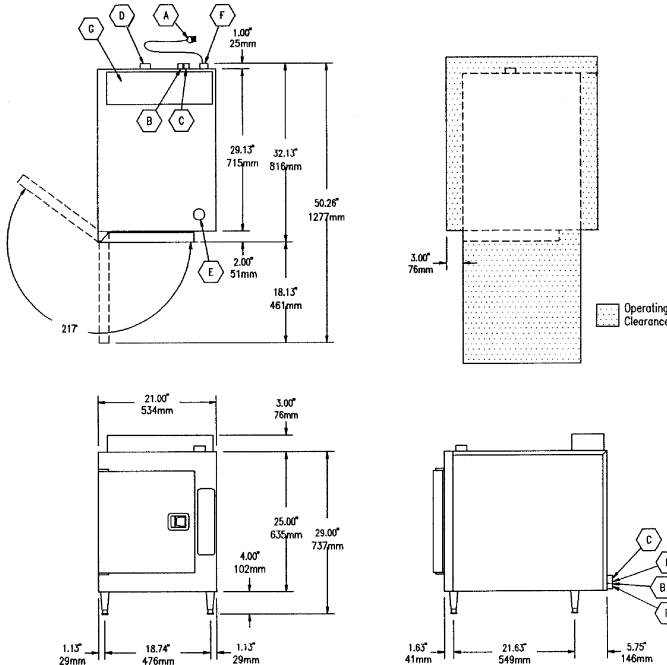

Shown with optional
Electronic Timer







SHORT FORM SPECIFICATION

Shall be CLEVELAND, SteamCraft® Ultra 5, one compartment, Counter-Type Steamer, Model 21-CGA-5, 75 M BTU, heavy duty all Stainless Steel construction; rear mounted, insulated Steam Generator with Remote Probe Type Water Level Controls and Automatic Steam Generator Blowdown with "Water Jet" Drain Cleaning feature.

WATER QUALITY REQUIREMENTS

The quality of water varies greatly from region to region. Steam equipment generators must be drained daily and chemically descaled periodically to ensure proper operation. To minimize service problems caused by the accumulation of minerals and chemicals in water review the following quality guidelines with a local water treatment specialist. Inlet water that is beyond these specified guidelines should be treated to achieve these acceptable limits. Total Dissolved Solids less than 60 ppm, Alkalinity less than 20 ppm, Silica less than 13 ppm, pH factor greater than 7.5, Chlorine less than 30 ppm.

TOTAL CAPACITY	
5 — 12" x 20" x 2½" Cafeteria Pans or	
10 — 12" x 20" x 1" Cafeteria Pans or	
3 — 12" x 20" x 4" Cafeteria Pans	
UTILITY CONNECTIONS	
(A) Electrical Supply	(E) Inlet for Generator Delimiting Solution
(B) Cold Water Supply for Condenser 1/4" Dia. IPS	(F) Gas Supply 1/2" (13mm) Dia. IPS
(C) Cold Water Supply for Generator and Water Injection. 1/4" Dia. IPS (for water treatment conn.) Inlet for Generator Delimiting Solution	(G) Flue Gas Exhaust from Boiler
(D) Drain: 1-1/4" (32mm) Dia. IPS	

GAS 	ELECTRIC 	COLD WATER 	DRAINAGE 				
1/2" (13mm) Dia. IPS	115V - 1 Phase 35 Watts	35 psi minimum 60 psi maximum  3/4" Dia. IPS for Generator (for water treatment connection)  1/2" Dia. IPS for Condenser	1½" Dia. IPS Do not connect any other units to this drain. Drain line must be vented. No PVC pipe for drain.				
SUPPLY PRESSURE <table border="1"> <thead> <tr> <th>NATURAL</th> <th>PROPANE</th> </tr> </thead> <tbody> <tr> <td>4.00" W.C. minimum 14.00" W.C. maximum</td> <td>12.00" W.C. minimum 14.00" W.C. maximum</td> </tr> </tbody> </table>		NATURAL	PROPANE	4.00" W.C. minimum 14.00" W.C. maximum	12.00" W.C. minimum 14.00" W.C. maximum		
NATURAL	PROPANE						
4.00" W.C. minimum 14.00" W.C. maximum	12.00" W.C. minimum 14.00" W.C. maximum						
Manufacturer must be notified if unit will be used above 2,000 ft. altitude.							

Cleveland Range reserves right of design improvement or modification, as warranted.

CLEVELAND RANGE 21CGA5
SEQUENCE OF OPERATIONS
STEAMCRAFT ULTRA 5
Mechanical Timer

1. To turn the unit on, depress the red on/off rocker switch.
2. 115 VAC is sent to the red indicator light.
3. 115 VAC is sent to the normally open drain valve closing it.
4. 115 VAC is sent through the normally closed water level (top) float switch to the coil of the R1 relay
 - The R1 relay energizes
 - The R1 contacts close 115 VAC is sent to the fill solenoid
5. The fill solenoid opens and the generator fills through the drain valve.
 - The water fills to the normally open low water cut off float switch (bottom float).
 - The float is lifted by the water and the switch closes.
 - The water fills to the normally closed water level (top) float switch.
 - The float is lifted by the water and the switch opens.
 - With the switch opened 115 VAC is removed from the coil of the R1 relay.
 - The R1 relay deenergizes and 115 VAC is removed from the fill solenoid and the unit stops filling
 - When the water level drops, the operational water float drops closing the switch and energizing the R1 relay
 - The R1 contacts close 115 VAC is sent to the fill solenoid. The unit fills back to the proper level.
6. When the timed/manual switch is in the timed position and time is on the timer
 - 115 VAC is sent from the timer to the R3 relay coil.
 - The R3 relay energizes
 - The R3B contacts close sending 115 VAC to the timer motor
 - The R3A contacts close sending 115 VAC through the optional door switch to the condensate valve and the primary of the 24 VAC ignition transformer.
 - 115 VAC is sent to the #4 terminal on the clean light timer.
 - The clean light timer counts down from the set time (time is set by dip switches on timer)
 - 115 VAC is sent to the amber light in the clean light switch.
 - The light is turned off and the clean light timer is reset by depressing the clean light timer switch.
 - With the sight glass filled the L.W.C.O. float will be raised and the normally open switch is closed.
 - 24 VAC is supplied from the secondary of the transformer through the L.W.C.O. float switch to the ignition module.

- Spark is sent to the igniter.
 - 24 VAC is sent to the gas valve.
 - The gas valve opens to the first stage (.7" W.C. natural gas and 2.25" LP) allowing gas to the burner.
 - 6 to 8 seconds later the valve opens to the second stage (3.5" W.C. natural gas and 10" W.C. LP)
 - When the gas is ignited the ignition module detects at least 1.5 micro-amps DC through the flame and burner ground wire.
 - If the 1.5 micro-amps DC is not detected in 4 seconds the ignition module locks out and has to be reset by removing 24 VAC to the module. This can be done by turning the steamer on and off.
7. With water in the generator and flame heating it, steam is made and directed into the cooking chamber.
8. The steamer will continue to steam until the timer runs down.
 - When the timer times down 115 VAC is removed from the R3 relay.
 - The R3 relay de energizes.
 - The R3B contacts open removing 115 VAC from the timer motor
 - The R3A contacts open removing 115 VAC from the heat circuit
 - 115 VAC is sent to the 3 second timer
 - 115 VAC sent to the buzzer for three seconds.
9. The steamer is turned off by depressing the on/off rocker switch.
 - 115 VAC is removed from the heat and timer circuits.
 - 115 VAC is removed from the drain valve.
 - 115 VAC is sent to the 3-minute timer and water is sent in to the now open drain valve flushing and cooling the drain.

STEAMCRAFT 5.1 GAS, MECHANICAL TIMER

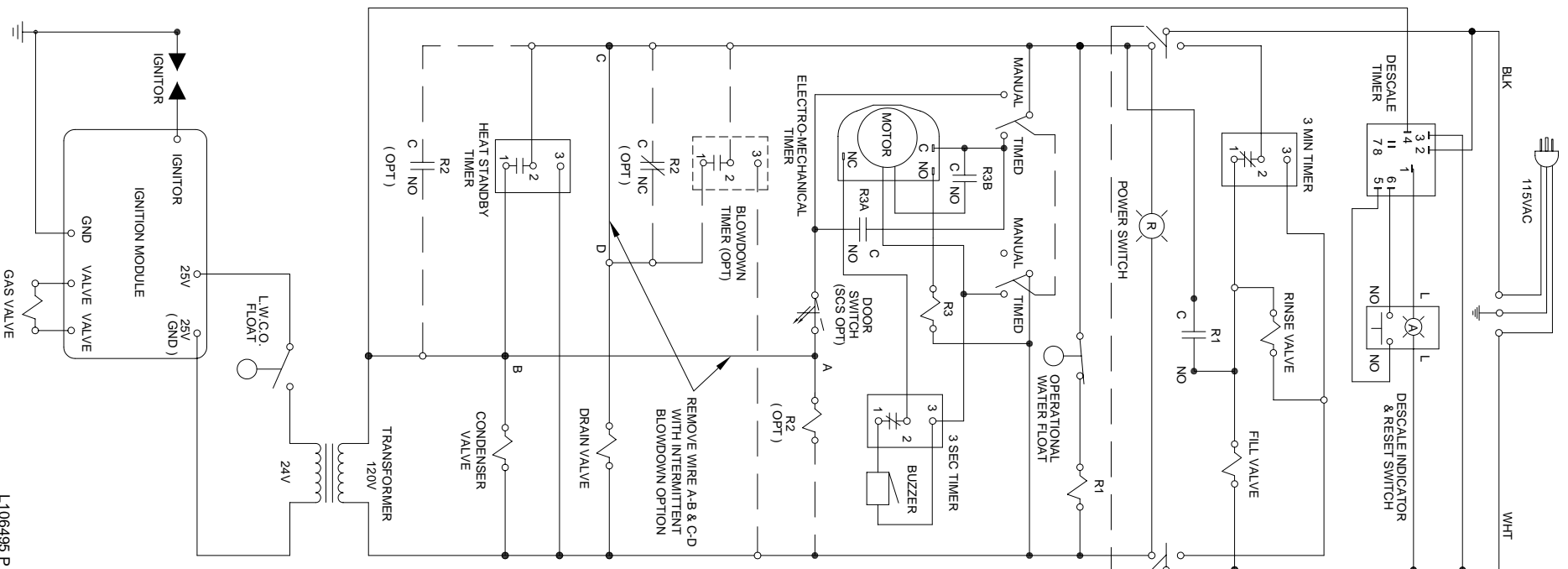

STEAMCRAFT 5.1 GAS w/MECHANICAL TIMER

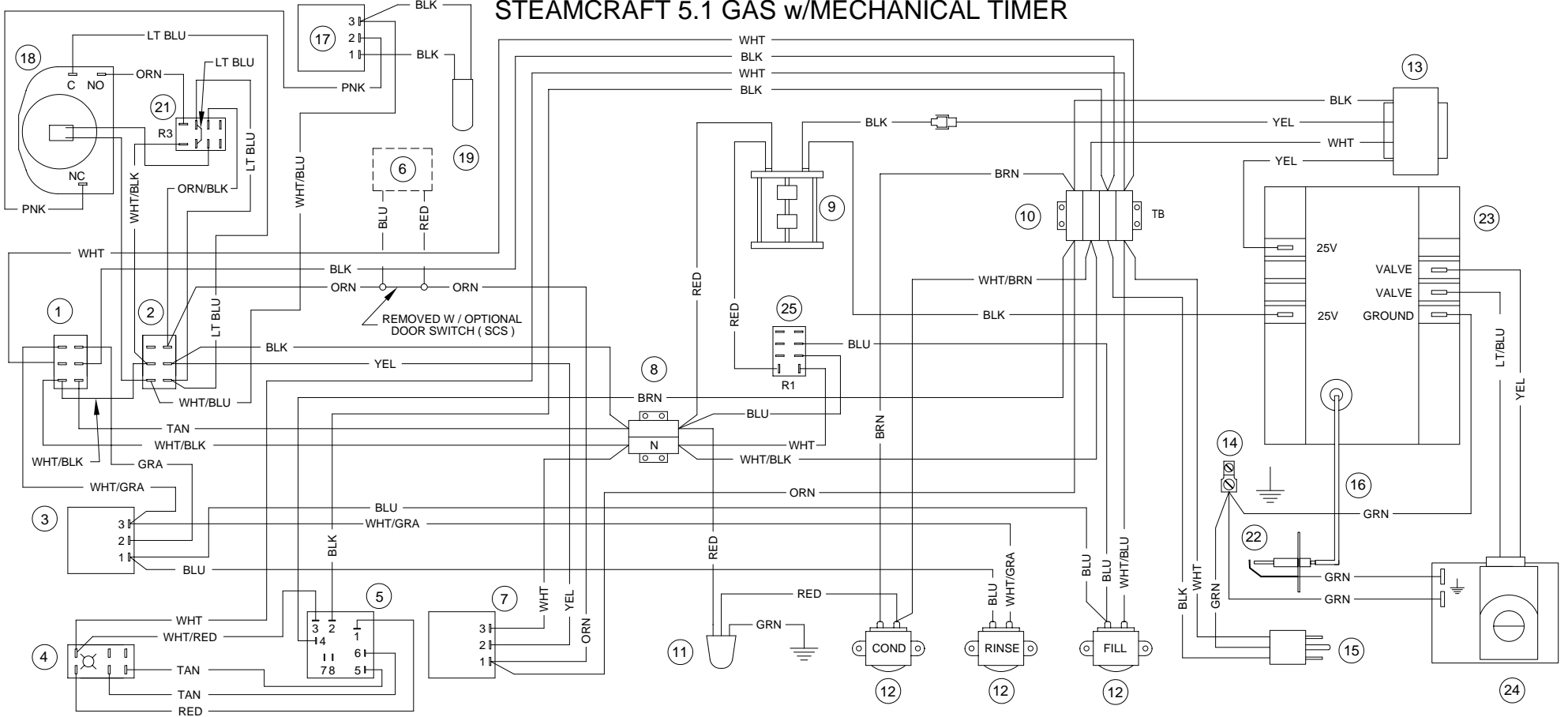

INTERMITTENT BLOWDOWN OPTION

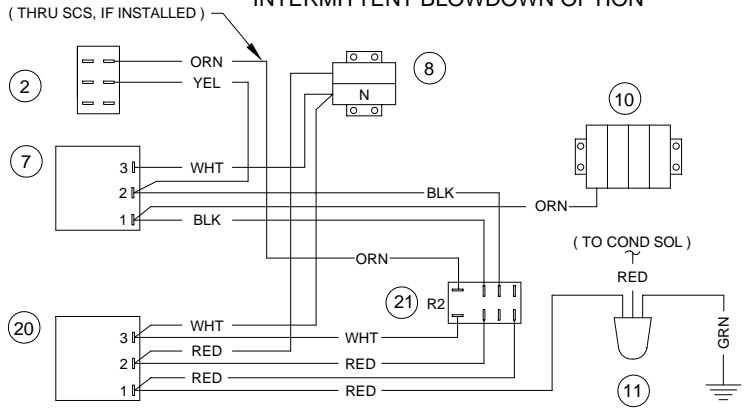

PARTS LIST

- | | | | | | |
|----|-------------------------------------|----|-------------------------------|----|----------------------------|
| 1 | 19993 - POWER SWITCH | 13 | 20528 - TRANSFORMER 24V | 24 | 106400 - GAS VALVE (NAT) |
| 2 | 104224 - TIMED/MANUAL SWITCH | 14 | 20304 - GROUND LUG | | 1064001 - GAS VALVE (LP) |
| 3 | 20478 - 3 MIN TIMER | 15 | 106461 - LINE CORD | 25 | 105966 - RELAY |
| 4 | 19994 - DESCALE INDICATOR RESET SW. | 16 | 1065681150 - IGNITION CABLE | | |
| 5 | 106911 - DESCALE TIMER | 17 | 20477 - 3 SEC TIMER | | |
| 6 | 108880 - DOOR SW (SCS) MAGNETIC | 18 | 110198 - MOTORIZED TIMER | | |
| 7 | 106580 - HEAT STANDBY TIMER | 19 | 41350 - BUZZER | | |
| 8 | 44168 - TERMINAL BLOCK | 20 | 106541 - INTMT BLOWDOWN TIMER | | |
| 9 | 103726 - FLOAT ASSEMBLY | 21 | 105966 - RELAY | | |
| 10 | 44164 - TERMINAL BLOCK | 22 | 300092 - IGNITOR | | |
| 11 | 22221 - DRAIN VALVE | 23 | 03546 - IGNITION MODULE | | |
| 12 | 22218 - WATER SOLENOIDS | | | | |

CLEVELAND RANGE 21CGA5
SEQUENCE OF OPERATIONS
Electronic Timer
Floats

1. To turn the unit on, depress the red on/off rocker switch.
2. 115 VAC is sent to the red indicator light.
3. 115 VAC is sent to the 24 VAC timer transformer.
 - 24 VAC is sent to the timer.
4. 115 VAC is sent to normally open drain valve closing it.
5. 115 VAC is sent through the normally closed operational water float switch (top float, red wires) to the fill solenoid.
6. The fill solenoid opens and the generator fills through the drain valve.
 - The water fills to the normally open low water cut off float switch (bottom float black wires).
 - The water lifts the float and the switch closes.
 - The water fills to the normally closed operational water float switch.
 - The water lifts the float and the switch opens.
 - With the switch opened 115 VAC is removed from the fill solenoid and the unit stops filling.
 - When the water level drops, the operational water float drops closing the switch and energizing the fill solenoid. The unit fills back to the proper level.
7. When the timed/manual switch is in the timed position and time is on the timer
 - The timer display will alternate between “PAUS” and the set time. This will continue until the cooking cabinet reaches 193 degrees and the thermal switch closes. Then the timer will begin timing down.
 - 115 VAC is sent from the timer through the optional door switch to the condensate valve and the primary of the 24 VAC ignition transformer.
 - 115 VAC is sent to the #4 terminal on the clean light timer.
 - The clean light timer counts down from the set time (time is set by dip switches on timer)
 - 115 VAC is sent to the amber light in the clean light switch.
 - The light is turned off and timer reset by depressing the clean light timer switch.
 - With the sight glass filled the L.W.C.O. float will be raised and the normally open switch is closed.
 - 24 VAC is supplied from the secondary of the transformer through the L.W.C.O. float switch to the ignition module.
 - Spark is sent to the igniter.
 - 24 VAC is sent to the gas valve.

- The gas valve opens to the first stage (.7" W.C. natural gas and 2.25" LP) allowing gas to the burner.
 - 6 to 8 seconds later the valve opens to the second stage (3.5" W.C. natural gas and 10" W.C. LP)
 - When the gas is ignited the ignition module detects at least 1.5 micro-amps DC through the flame and burner ground wire.
 - If the 1.5 micro-amps DC is not detected in 4 seconds the ignition module locks out and has to be reset by removing 115 VAC to the module.
8. With water in the generator and flame heating it steam is made and directed into the cooking chamber.
9. The steamer will continue to produce steam until the timer counts down.
 - When the timer times down 115 VAC is removed from the heat circuit and condensate circuit.
10. The steamer is turned off by depressing the on/off rocker switch.
 - 115 VAC is removed from the heat and timer circuits.
 - 115 VAC is removed from the drain valve.
 - 115 VAC is sent to the 3-minute timer and water is sent in to the now open drain valve flushing and cooling the drain.

STEAMCRAFT 5.1 GAS, ELECTRONIC TIMER

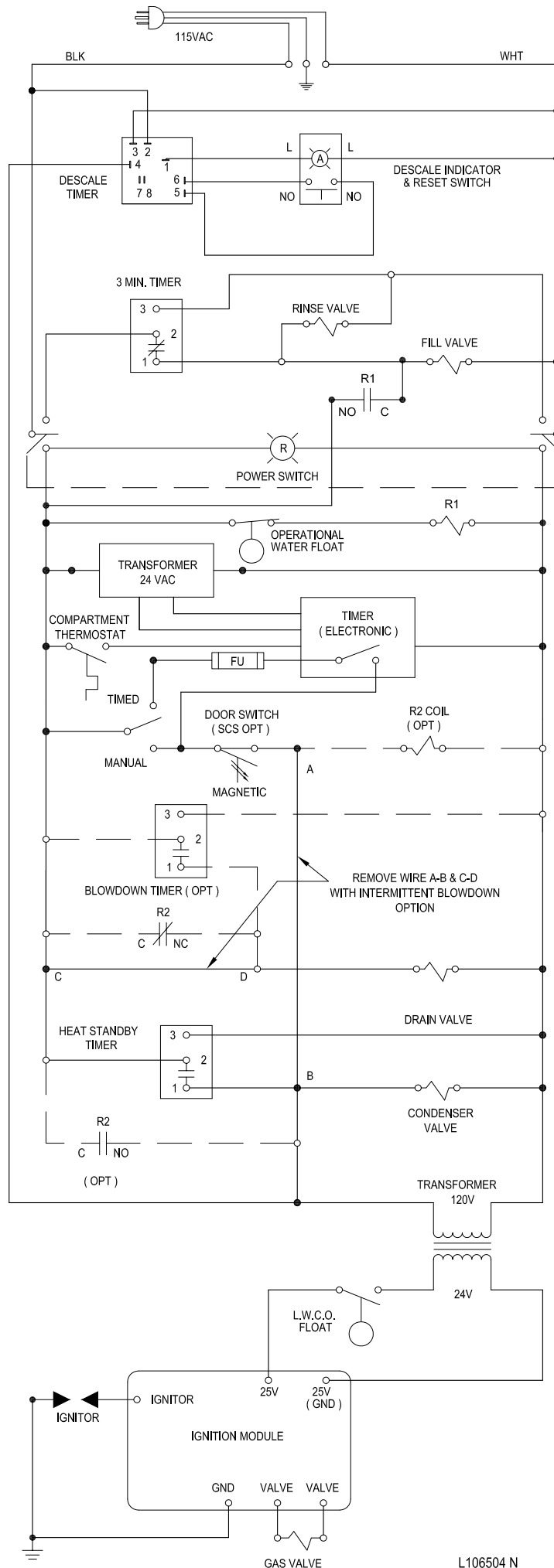

STEAMCRAFT 5.1 GAS w/ELECTRONIC TIMER

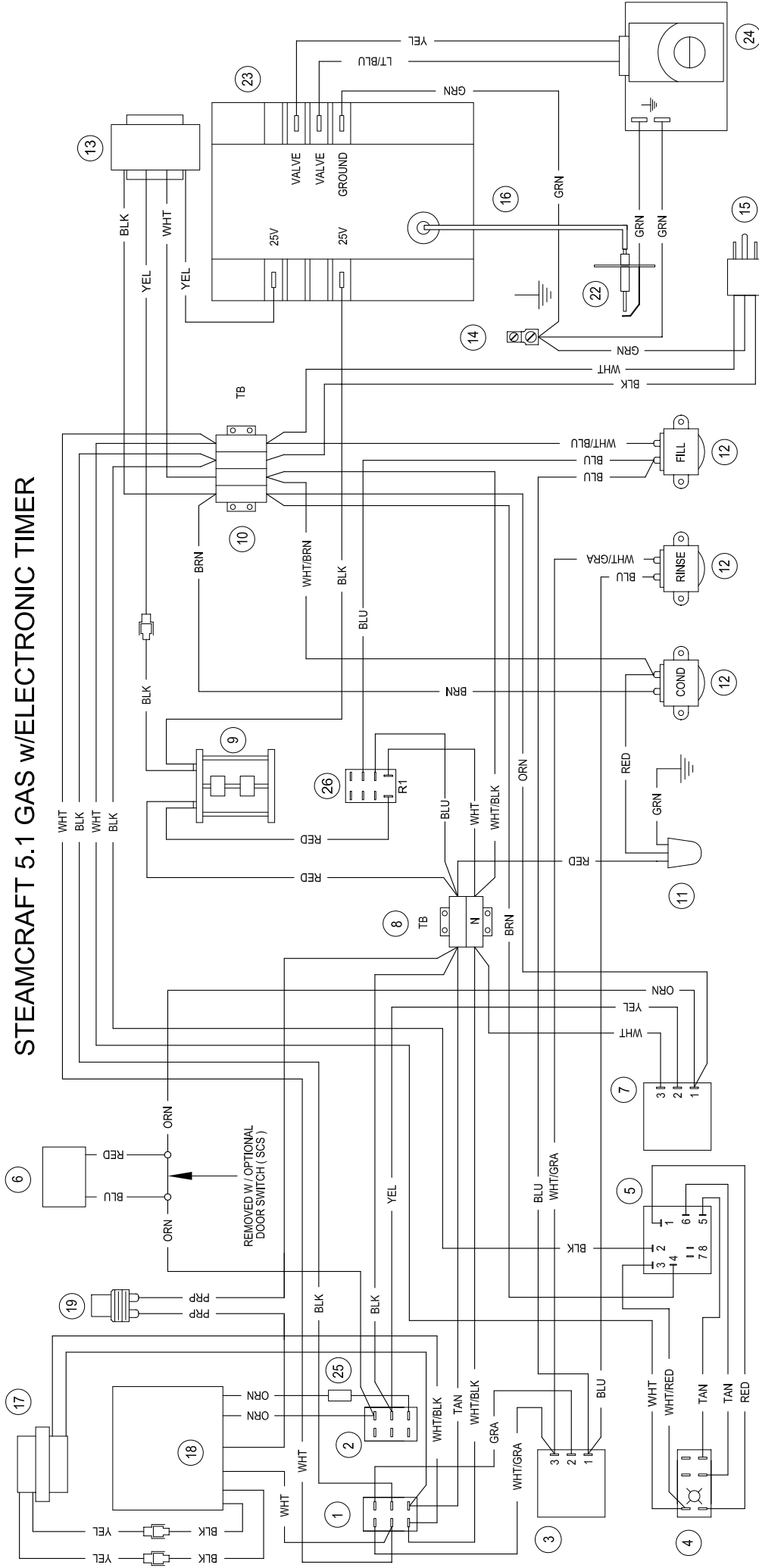

PARTS LIST

- | | | | | | |
|----|------------------------------------|----|-------------------------------|----|----------------------------|
| 1 | 19993 - POWER SWITCH | 12 | 22218 - WATER SOLENOIDS | 23 | 03546 - IGNITION MODULE |
| 2 | 104224 - TIMED / MANUAL SWITCH | 13 | 20528 - TRANSFORMER 24V | 24 | 106400 - GAS VALVE (NAT) |
| 3 | 20478 - 3 MIN TIMER | 14 | 20304 - GROUND LUG | 25 | 1064001 - GAS VALVE (LP) |
| 4 | 19994 - DESCALC INDICATOR RESET SW | 15 | 106461 - LINE CORD | 26 | 106909 - 2 AMP, 250V FUSE |
| 5 | 106911 - DESCALC TIMER | 16 | 1065881150 - IGNITION CABLE | | 105966 - RELAY |
| 6 | 108880 - DOOR SW (SCS) MAGNETIC | 17 | 104390 - TRANSFORMER | | |
| 7 | 106580 - HEAT STANDBY TIMER | 18 | 104389 - ELECTRONIC TIMER | | |
| 8 | 44168 - TERMINAL BLOCK | 19 | 19972 - THERMAL SWITCH | | |
| 9 | 103726 - FLOAT ASSEMBLY | 20 | 106541 - INTMT BLOWDOWN TIMER | | |
| 10 | 44164 - TERMINAL BLOCK | 21 | 105966 - RELAY | | |
| 11 | 22221 - DRAIN VALVE | 22 | 300092 - IGNITOR | | |

INTERMITTENT BLOWDOWN OPTION

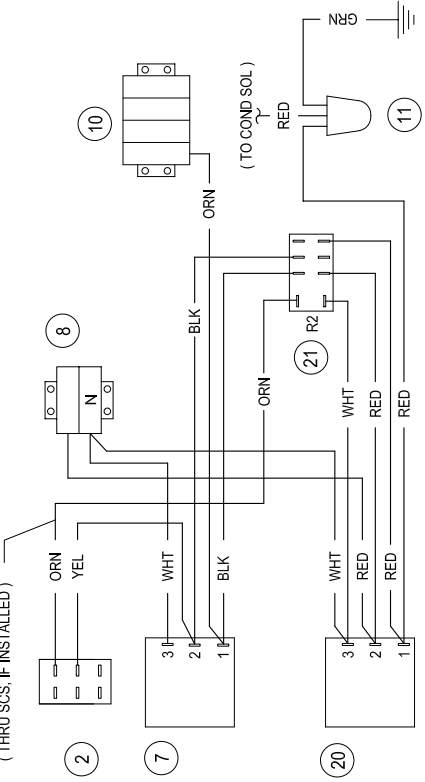

PROBLEM:
21CGA5
Steam
cabinet won't
steam with time on
the timer and time/
manual switch in
the timed position

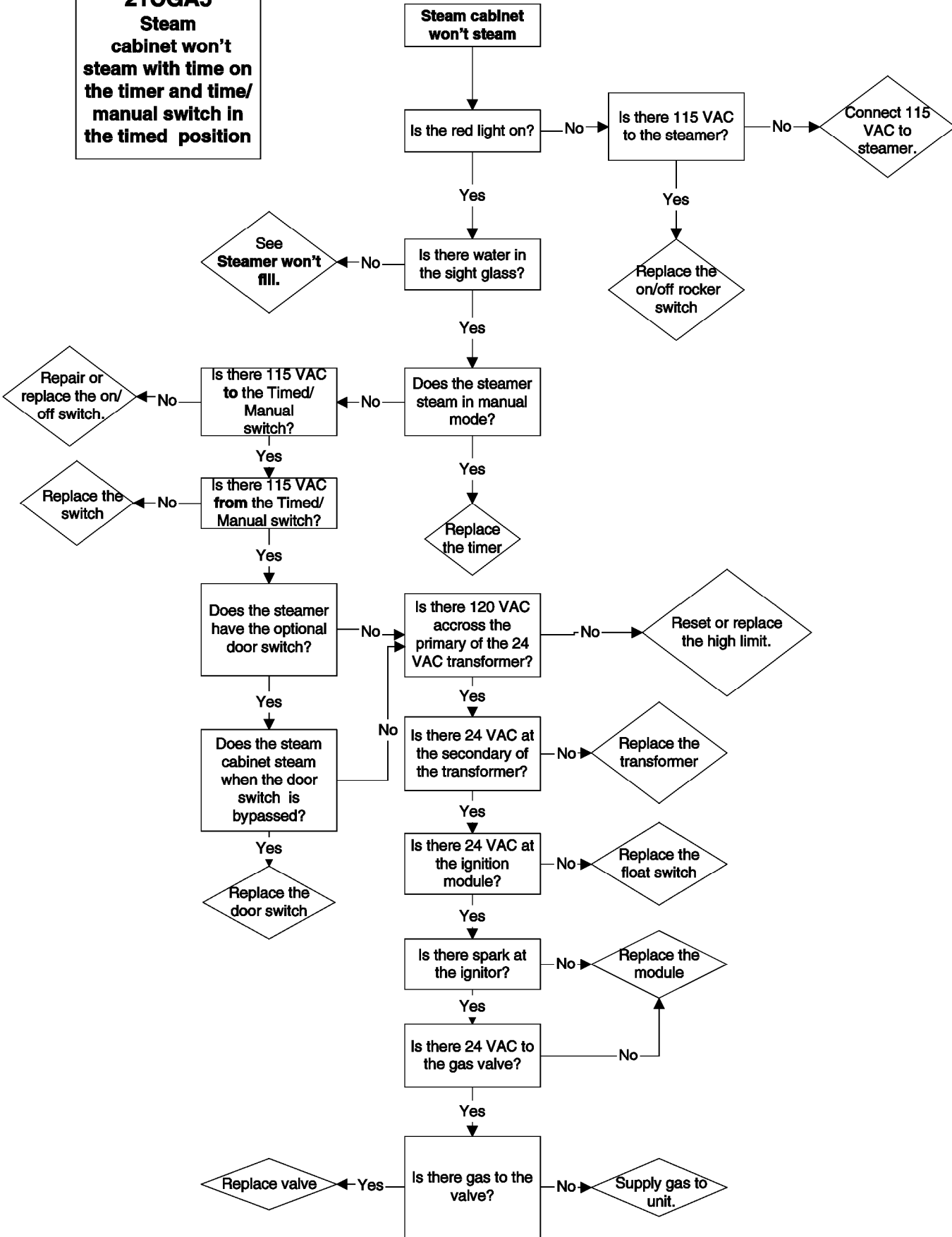

**PROBLEM:
21CGA5
Steam
generator
won't fill**

**Steam generator
won't fill.**

Yes

Is there 115 VAC to the steamer?

No → Supply 115 VAC to the steamer.

Yes

Is there water to the steamer?

No → Supply cold water to the steamer.

Yes

Does steamer fill with float switch (2 red wires) by-passed?

Yes → Replace the float switch.

No

Is there 120 VAC across the coil of the fill solenoid?

No → Replace the wiring to the fill solenoid.

Yes

Is water leaving the fill solenoid?

No → Replace the fill solenoid

Yes

Is there 120 VAC across the coil of the drain valve?

No → Replace wiring to drain solenoid.

Yes

Is water draining from the generator?

No → If water is leaving the fill solenoid and not draining from the generator where is it going? check for leaks..

Yes

Replace the drain valve.

Does the steamer have the optional intermittent blowdown timer?

No → Replace wiring to drain solenoid.

Yes

Is there 120 VAC between terminals 2&3 on the timer?

No → Replace the wiring to the intermittent blowdown timer .

Yes

Replace the intermittent blowdown timer.

**PROBLEM:
21CGA5
Electronic timer displays "PAUS" and won't count down**

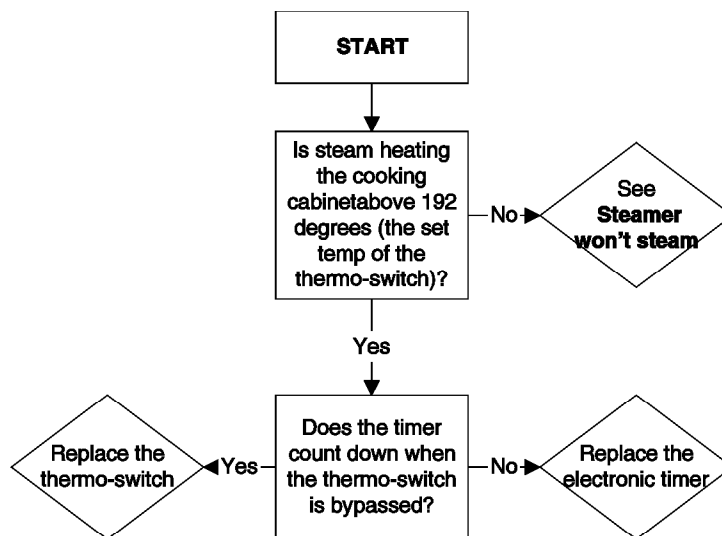

**PROBLEM:
21CGA5
Steam leaks around the door.**

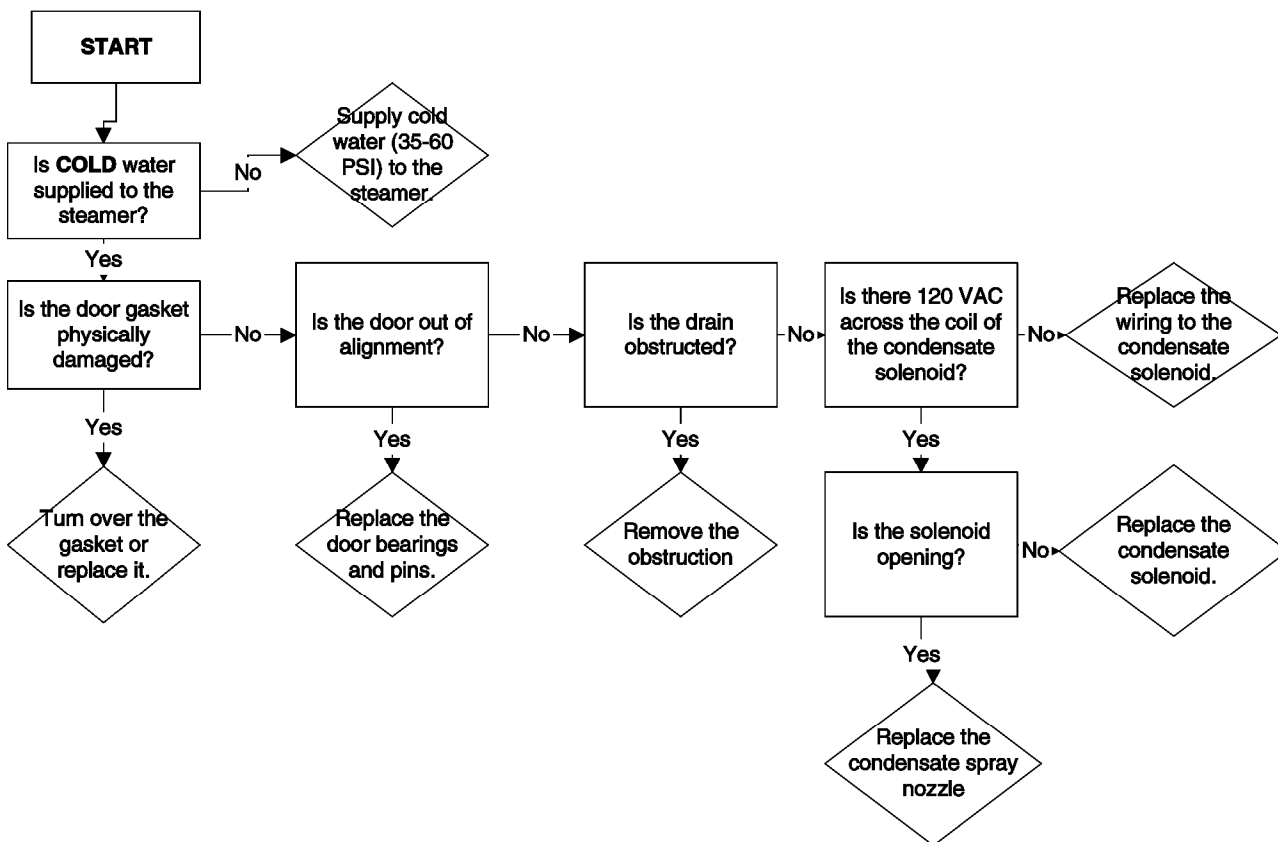

**PROBLEM:
21CGA5
Steamer overfills.
(Water sprays into cooking cabinet)**

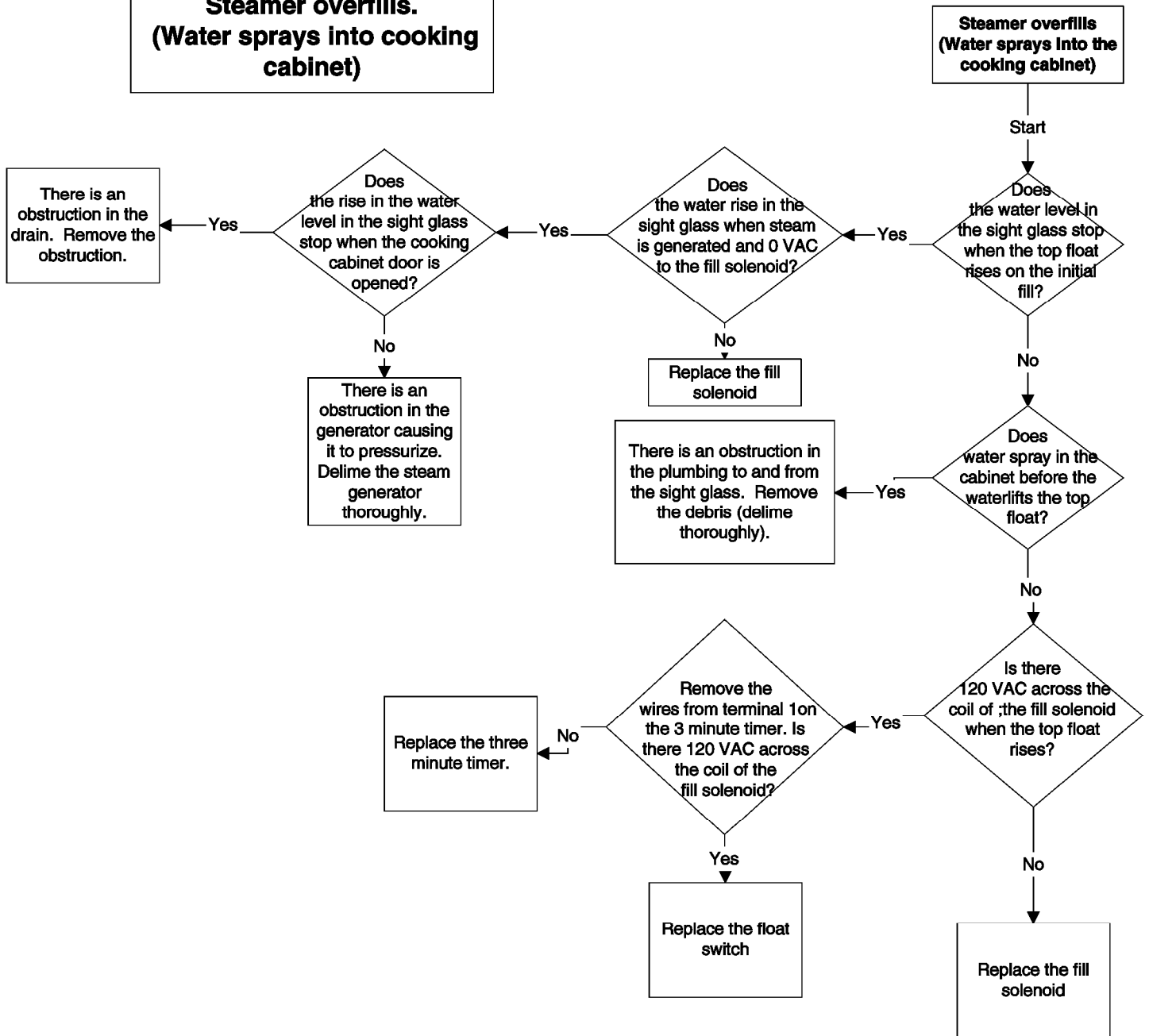

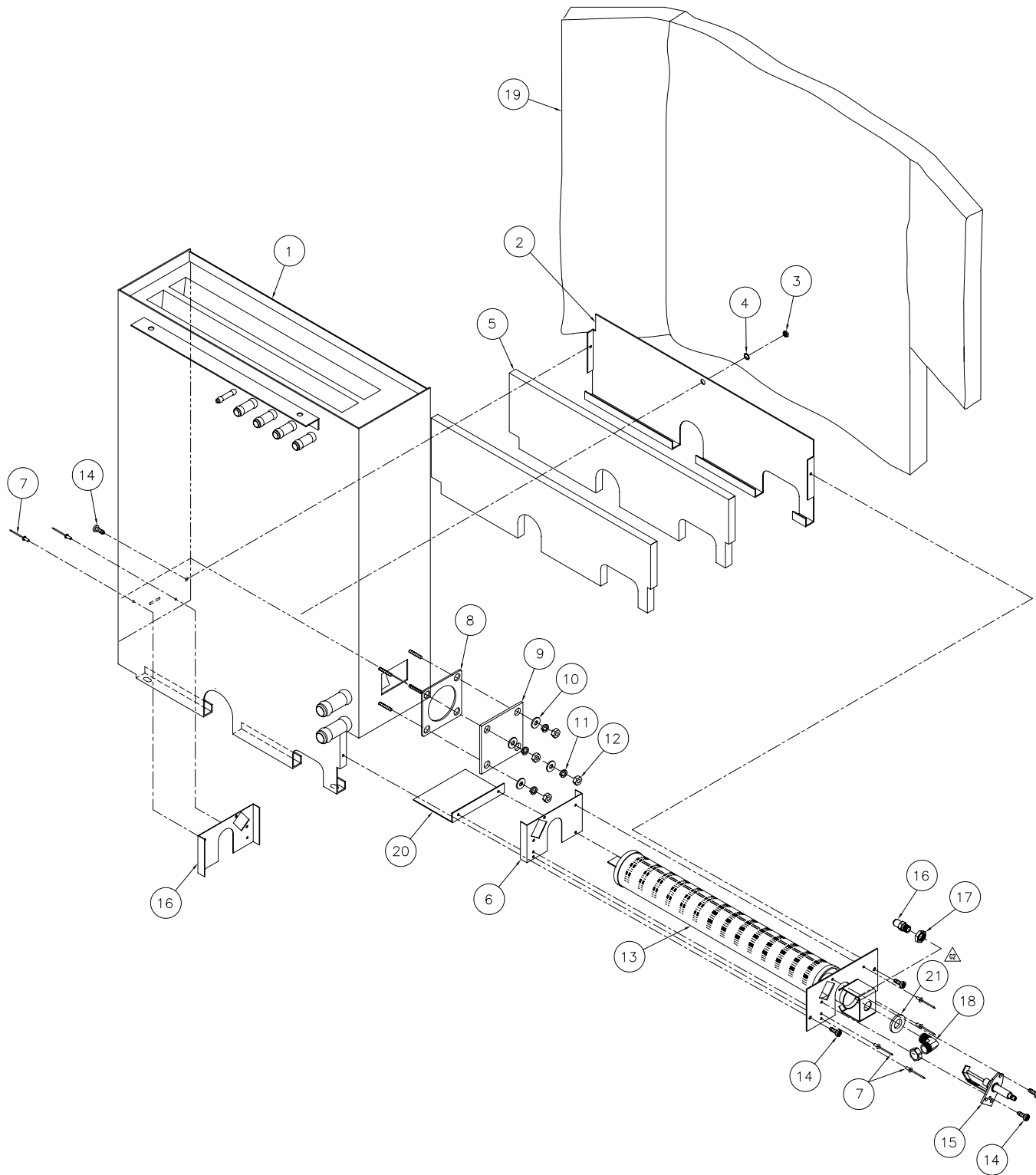

21	-	100539	WASHER, 0.563 ID
20	1	111146	BAFFLE, BURNER, 21CGA5
19	1	106408	INSULATION, GENERATOR WRAP
18	-	106459	FITTING, COMPRESSION, 1/2 T x 1/4-18 NPT, 90°, MOD
17	-	106460	NUT, 1/4-18 NPT, BRASS
16	-	1064021	ORIFICE, #41 DRILL, LP GAS
16	-	106402	ORIFICE, #21 DRILL, NATURAL GAS
15	-	300092	ELECTRODE, REVERSED, COMBINATION IGNITOR/SENSOR
14	5	106126	SCREW, TORX, 8-32 x 1/2
13	-	106582	BURNER, WELD ASSEMBLY
12	4	14618	NUT, HEX, 1/4-20
11	4	23105	WASHER, LOCK, 1/4, SST
10	4	23116	WASHER, FLAT, 1/4 ID x 5/8 OD
9	1	104614	COVER, BLOCK-OFF
8	1	07128	GASKET, HEATER
7	6	18358	RIVET, 1/8 DIA., FLUSH BREAK, SST
6	2	106362	BRACKET, SIDE, INSULATION SUPPORT
5	2	106360	INSULATION, CUT, COMBUSTION CHAMBER
4	1	23114	WASHER, LOCK, INT. TOOTH, #10
3	1	14659	NUT, HEX, 10-24
2	1	106361	BRACKET, REAR, INSULATION SUPPORT
1	1	106407	GENERATOR ASSY, WELD, SC 5.1 GAS



Cleveland

Descaling Procedure-SteamCraft Ultra and Gemini Series

How Much DISSOLVE to Use

Model	Dissolve
Ultra 3	1/2 Gallon
Ultra 5	1 Gallon
Ultra 10 (Elec.)	1 Gallon (ea.)
Ultra 10 (Gas)	1½ Gallon
Gemini 6 & 10	1 Gallon (ea.)

1. Turn the unit OFF and open the doors:

This will drain and rinse the generator for about 3 minutes.

2. Turn the unit power back On:

The generator will begin to refill with water.

3. Select Timed with the Timed/Manual switch:

DO NOT start the timer, since you do not want to heat the water during descaling. Leave the doors open.

4. Remove descaling port cap and add with the specified amount of DISSOLVE: (See chart above)

Do this while the unit is refilling. The generators can take-up to 8 minutes to refill.

5. After refill has stopped, add extra tap water into the descaling port until liquid is seen entering the cooking cabinet. Note: Ultra 10 gas will have liquid coming out of the drain,

Adding extra water when descaling will raise the descaling solution higher than the normal fill level, allowing the DISSOLVE to work on sensors and surfaces above the water line

Note: Some SteamCraft Ultra models (the electric powered Ultra 10 and Gemini 6 and 10, for example) have two generators and two descaling ports. Both units should be descaled at the same time, using this procedure

6. Let the descaler soak in generator for approximately one hour:

7. After one hour, turn the unit power Off: This will drain and rinse the generator for about 3 minutes.



8. After the 3-minute drain cycle completes, turn the unit back ON. After the filling has stopped, add water until liquid enters the cooking compartment (or drain for the ultra 10 gas), and then turn the unit OFF. This will drain and flush any residue from the water level control assembly. Replace descaling cap.

9. After the 3 minute drain cycle completes, Turn the unit ON and set the Timer for 20 minutes: Make sure the Time/Manual switch is in the timed setting and the doors are closed.

10. When the timer times out (after 20 minutes) turn the power Off:

This will drain and rinse the generator for about 3 minutes.

This ends the descaling procedure. You can now turn the unit back on and resume normal startup and cooking operations.