



Visit [www.clevelandrange.com](http://www.clevelandrange.com) to locate a service or sales representative in your area.

# Cleveland

## SteamChef

### Electric Connectionless Convection Steamers with Easy Timer

#### Operation, Installation & Maintenance Manual

This manual is updated as new information and models are released. Visit our website for the latest manual.

**MODELS:**

22CCT6

*For your future reference.*

Model # \_\_\_\_\_

Serial # \_\_\_\_\_



***Read the manual thoroughly. Improper installation, operation or maintenance can cause property damage, injury, or death.***

# **STATEMENT OF RESPONSIBILITIES / DÉCLARATION DES RESPONSABILITÉS / DECLARACIÓN DE RESPONSABILIDADES**

This document is for use by experienced and trained Qualified Cleveland Range, LLC Authorized Service Representatives who are familiar with both the safety procedures, and equipment they service. Cleveland Range, LLC assumes no liability for any death, injury, equipment damage, or property damage resulting from use of, improper use of, or failure to use the information contained in this document. Cleveland Range, LLC has made every effort to provide accurate information in this document but cannot guarantee that this document does not contain unintentional errors and omissions.

The information in this document may be subject to technical and technological changes, revisions, or updates. Cleveland Range, LLC assumes no liability or responsibility regarding errata, changes, revisions, or updates.

Qualified Cleveland Range, LLC Authorized Service Representatives are obligated to follow industry standard safety procedures, including, but not limited to, OSHA regulations, and disconnect / lock out / tag out procedures for all utilities including steam, and disconnect / lock out / tag out procedures for gas, electric, and steam powered equipment and / or appliances.

All utilities (gas, electric, water and steam) should be turned OFF to the equipment and locked out of operation according to OSHA approved practices during any servicing of Cleveland Range equipment.

Qualified Cleveland Range, LLC Authorized Service Representatives are obligated to maintain up-to-date knowledge, skills, materials, and equipment.

Ce document est destiné à l'usage des Représentants de Service qualifiés et autorisés de Cleveland Range, LLC qui possèdent l'expérience et la formation ainsi que la bonne connaissance des mesures de sécurité et du matériel qu'ils entretiennent.

Cleveland Range, LLC décline toute responsabilité pour tout cas de décès, blessure, dommage matériel ou dommage aux biens résultant de l'utilisation, de la mauvaise utilisation ou du manquement d'utilisation des renseignements contenus dans ce document.

Cleveland Range, LLC s'est efforcé à fournir des renseignements précis dans ce document mais ne peut garantir que ce document soit exempt d'erreurs et d'omissions non intentionnelles.

Les renseignements contenus dans ce document peuvent être assujettis à des changements techniques et technologiques, des révisions ou des mises à jour.

Cleveland Range, LLC décline toute obligation ou responsabilité concernant les errata, modifications, révisions ou mises à jour.

Les Représentants de Service qualifiés et autorisés de Cleveland Range, LLC sont tenus de se conformer aux mesures de sécurité normalisées de l'industrie, y compris, mais sans s'y limiter, les réglementations de l'OSHA, les procédures de débranchement / verrouillage / étiquetage relatives à tous les services publics, dont l'approvisionnement en vapeur, et les procédures de débranchement / verrouillage / étiquetage relatives aux équipements et/ou appareils fonctionnant au gaz, à l'électricité et à la vapeur.

Au cours de tout entretien d'un appareil Cleveland Range, tous les services publics (gaz, électricité, eau et vapeur) doivent être FERMÉS au niveau de l'appareil et le dispositif de fonctionnement doit être verrouillé suivant les pratiques approuvées de l'OSHA.

Les Représentants de Service qualifiés et autorisés de Cleveland Range, LLC sont tenus d'actualiser en permanence leurs connaissances, compétences, matériel et équipement.

Este documento está destinado para el uso de los Representantes de Servicio calificados y autorizados de Cleveland Range, LLC quienes cuentan con la experiencia y la capacitación, así como el buen conocimiento de las medidas de seguridad y de los equipos que mantienen.

Cleveland Range, LLC, declina toda responsabilidad en caso de cualquier fallecimiento, lesiones, daños al equipo o daños a la propiedad resultantes de la utilización, del uso indebido o de la falta de utilización de la información provista en este documento.

Cleveland Range, LLC se ha esforzado en suministrar información precisa en este documento, pero no puede garantizar que este documento esté exento de errores y de omisiones no intencionales.

La información contenida en este documento podría estar sujeta a cambios técnicos o tecnológicos, revisiones o actualizaciones. Cleveland Range, LLC declina toda obligación o responsabilidad con respecto a erratas, modificaciones, revisiones o actualizaciones.

Los Representantes de Servicio calificados y autorizados de Cleveland Range, LLC tienen la obligación de seguir los procedimientos estándar de seguridad de la industria; los cuales incluyen pero no se limitan a los reglamentos de la OSHA (La Administración de la Seguridad y Salud Ocupacionales), los procedimientos de desconexión, cierre y etiquetado relativos a todos los servicios públicos incluyendo el suministro de vapor y los procedimientos de desconexión, cierre y etiquetado para los equipos y/o aparatos que funcionan a base de gas, electricidad o vapor.

Cuando se esté dando servicio o mantenimiento a un aparato de Cleveland Range, todos los servicios públicos (gas, electricidad, agua y vapor) deben estar APAGADOS para el equipo en cuestión y se debe seguir el procedimiento de cierre de operaciones de acuerdo con las prácticas aprobadas por la OSHA.

Los Representantes de Servicio calificados y autorizados de Cleveland Range, LLC tienen la obligación de actualizar constantemente sus conocimientos, destrezas, materiales y equipamiento.

**FOR YOUR SAFETY / POUR VOTRE SÉCURITÉ /  
PARA SU SEGURIDAD**

**FOR YOUR SAFETY**

Do not store or use gasoline or any other flammable liquids and vapours in the vicinity of this or any other appliance.

**WARNING:** Improper installation, operation, adjustment, alteration, service, or maintenance can cause property damage, injury or death. Read the installation and operating instructions thoroughly before installing, operating, or servicing this equipment.

Do not spray aerosols in the vicinity of this appliance while it is in operation.

This appliance is not to be used by persons with reduced physical, sensory, or mental capabilities, or lack of experience and knowledge, unless they have been given supervision or instruction concerning use of the appliance by a person responsible for their safety.

This appliance is not for use by children, and they must be supervised not to play with it.

Retain this manual for your reference.

**POUR VOTRE SÉCURITÉ**

Ne pas entreposer ou utiliser d'essence ou d'autres liquides ou vapeurs inflammables à proximité de cet appareil ou de tout autre appareil.

**AVERTISSEMENT :** Toute mauvaise pratique en matière d'installation, de fonctionnement, de réglage, de modification, d'entretien ou de maintenance peut causer des dommages matériels, des blessures ou la mort. Lisez la totalité des instructions d'installation et d'utilisation avant d'installer, d'utiliser ou d'entretenir cet équipement.

Ne pas pulvériser des aérosols dans le voisinage de cet appareil alors qu'il est en fonctionnement.

Cet appareil ne doit pas être utilisé par des personnes dont les capacités physiques, sensorielles ou mentales sont réduites, ou des personnes dénuées d'expérience ou de connaissance, sauf si elles ont pu bénéficier, par l'intermédiaire d'une personne responsable de leur sécurité, d'une surveillance ou d'instructions préalables concernant l'utilisation de l'appareil.

Conservez ce manuel pour votre référence.

**PARA SU SEGURIDAD**

No guarde ni use gasolina o cualesquiera otros líquidos o vapores inflamables en las cercanías de éste o cualquier otro aparato.

**ADVERTENCIA:** La indebida instalación, operación, ajuste, modificación, servicio o mantenimiento puede ocasionar daños a la propiedad, lesiones o muerte. Lea detenidamente las instrucciones de instalación y de operación antes de instalar, poner a funcionar o dar servicio a este equipo.

No pulverice aerosoles en las proximidades de este aparato mientras está en funcionamiento.

Este aparato no debe ser utilizado por personas con capacidades físicas, sensoriales o mentales reducidas, o que no tengan la experiencia y los conocimientos adecuados, a menos que estas personas hayan recibido supervisión e instrucciones en cuanto al uso del aparato por la persona responsable de la seguridad de ellas.

Guarde este manual para su referencia.

## WARNING / AVERTISSEMENT / ADVERTENCIA



Inspect unit daily for proper operation. / Inspecter le bloc quotidiennement pour garantir le fonctionnement normal. / Inspeccione diariamente el funcionamiento correcto de la unidad.



Heavy. / Lourd. / Pesado.

Team or mechanical lift. / Levage en équipe ou mécanique. / Levantamiento en equipo o mecánico.



Surfaces may be extremely hot! Use protective equipment. / Les surfaces peuvent être extrêmement chaudes ! Utiliser des équipements de protection. / ¡Las superficies pueden estar muy calientes! Utilice equipo protector.



Do not climb, sit, or stand on equipment. / Il ne faut pas monter, s'asseoir ni se tenir debout sur l'équipement. / No subirse, ni sentarse ni pararse sobre el equipo.



Do not remove guards or operate without them. / Ne pas supprimer les gardes ou fonctionner sans eux. / No retire los guardias ni funcionar sin ellos.



Keep hands away from moving parts and pinch points. / Tenir les mains à l'abri des pièces mobiles et des angles. / Mantenga las manos lejos de las piezas móviles y los puntos de presión.



Hot product and surfaces. / Produit et surfaces chaudes. / Producto y superficies calientes.



Keep clear of pressure discharge. / Se tenir hors de portée de la purge des soupapes de surpression. / Manténgase alejado de la descarga de presión.



Unit must be anchored as per manual. / Unité doit être ancrée selon les directives du manuel. / Unidad debe estar fijado según el manual.



Floor may become slippery from product spillage. / Déversement de produit peut causer de plancher à être glissant. / Derrame de producto puede causar piso a ser resbaladizo.



Have a qualified service technician maintain your equipment. / Demandez à un technicien en entretien et en réparation qualifié d'effectuer l'entretien de votre équipement. / Haga que un técnico de servicio calificado mantenga su equipo.



Shut off power at main fuse disconnect prior to servicing. / Couper l'alimentation sur le principal fusible sectionneur avant l'entretien. / Apague la alimentación eléctrica en el fusible desconector principal antes de darle servicio.



Ensure equipment is at room temperature and pressure gauge is showing zero or less prior to removing any fittings. / S'assurer que le chaudron se trouve dans une température ambiante et que le manomètre affiche zéro ou moins avant de déposer les raccords. / Asegúrese de que la marmita está a temperatura ambiente y el manómetro está mostrando cero o menos antes de quitar cualquier accesorio.



Appliance must not be supplied through an external switching device that is regularly switched on and off. / L'appareil ne doit pas être alimenté par un interrupteur externe régulièrement allumé et éteint. / El aparato no debe ser alimentado a través de un dispositivo de conmutación externo que se encienda y apague periódicamente.

**OPERATION, INSTALLATION & MAINTENANCE MANUAL MODEL  
22CCT6**

**TABLE OF CONTENTS**

<b>CHAPTER 1 GENERAL INFORMATION .....</b>	<b>5</b>
A. Laws, Codes, and Regulations.....	5
B. Operational Safety .....	5
C. Inspection for Shipping Damage .....	5
<b>CHAPTER 2 PRODUCT INFORMATION .....</b>	<b>6</b>
A. Product Information.....	6
B. Model Numbers and Serial Numbers .....	6
C. Product Information Plate.....	6
D. Product Views .....	6
<b>CHAPTER 3 INSTALLATION PROCEDURE .....</b>	<b>9</b>
A. Select a Location .....	9
B. Installation of a SteamChef 22CCT6 .....	9
C. Position and Level.....	10
D. Install/Remove the Slide Racks (Pan Racks) .....	10
E. Install/Remove the KleanShield™ .....	10
F. Install the Fan Guard and Air Diverter .....	11
G. Install/Remove the Bypass Shield.....	11
H. Electric Power Supply .....	12
I. Installation Checklist .....	13
<b>CHAPTER 4 COOKING WITH THE 22CCT6.....</b>	<b>14</b>
A. Cooking Procedure: .....	14
B. Rethermalization: .....	15
<b>CHAPTER 5 EASY TIMER OPERATING INSTRUCTIONS .....</b>	<b>16</b>
A. Main External Power Switch.....	17
B. Inspect the Cooking Compartment .....	17
C. Manual Water Fill .....	17
D. Power ON .....	18
E. Preheat Steamer.....	19
F. High Limit Reset.....	19
G. Water Refill .....	19
<b>CHAPTER 6 SHUTDOWN AND CLEANING PROCEDURE.....</b>	<b>20</b>
<b>CHAPTER 7 OPERATING TESTS AND FINAL CHECKOUT PROCEDURES.</b>	<b>22</b>
A. Startup Procedure .....	22
B. Operating Tests and Final Checkout Procedure.....	22
<b>CHAPTER 8 PREVENTIVE MAINTENANCE .....</b>	<b>24</b>
A. Maintenance.....	24
B. Descaling Water Reservoir .....	24
<b>CHAPTER 9 TROUBLESHOOTING GUIDE.....</b>	<b>27</b>

# CHAPTER 1 GENERAL INFORMATION

## A. Laws, Codes, and Regulations

This equipment should be installed only by qualified, professional plumbers, pipe fitters, and electricians.

1. The installation of this appliance must conform with:
  - a) The National Electrical Code, ANSI/NFPA 70 (latest edition), or the Canadian Electrical Code, CSA C22.2, or local codes, as applicable.
    - When installed, the appliance must be electrically grounded in accordance with the above.
    - **NOTE:** This appliance is not GFI (GFCI) compatible.
  - b) The *Food Code* (latest edition) of the Food and Drug Administration (FDA).
2. This equipment is to be installed to comply with the applicable federal, state, or local plumbing codes.
3. Installation instructions must be read in their entirety before starting installation of this appliance.
4. Install this appliance according to the policies and procedures outlined in this manual.
5. Installation must comply with all local fire and health codes.

### **DANGER**

Improper installation, adjustment, alteration, service, or maintenance of this appliance, or installation of a damaged appliance can result in DEATH, INJURY, EQUIPMENT DAMAGE, and void the warranty.

NEVER install damaged appliances, equipment, or accessories.

ALWAYS have installation and service performed by qualified Cleveland Range authorized personnel.

## B. Operational Safety

The Operational Safety section outlines minimum safety policies and procedures for operating one or more Cleveland Range appliances.

1. Do not store anything on top and underneath the appliance.
2. KEEP THE APPLIANCE AREA FREE AND CLEAR OF COMBUSTIBLES.
3. Proper air supply for ventilation is REQUIRED for and CRITICAL to safe, efficient operation of this appliance.
4. Place non-slip draining anti-fatigue mats rated for use in wet, greasy, or dry work areas on the floor in front of the appliance and other locations as needed. Obtain the best mats for your needs from your local supplier.
5. Wear BOOTS appropriate to the work area to help protect feet, and to help prevent slips and falls.
6. Allow only qualified Cleveland Range authorized service representatives to service the appliance.
7. Use only factory authorized repair parts.
8. Maintain written records of appliance service, maintenance, and repair. See Chapter 9.

### **DANGER**

Operating this appliance out of level can cause DEATH, INJURY, and EQUIPMENT DAMAGE.

This appliance must be level both front-to-back and side-to-side in all installations.

NEVER operate this appliance out of level.

If this appliance is suspected to be out of level, shut it down at once and call your qualified Cleveland Range authorized service agency immediately.

## C. Inspection for Shipping Damage

If the appliance is damaged or damage is suspected:

1. Submit a Damage Claim to the shipper and inform your dealer immediately.
2. Inform Cleveland Range in writing within three (3) days.

## CHAPTER 2 PRODUCT INFORMATION

---

### A. Product Information

- This manual covers the operation of 22CCT6 (Connectionless Chef) and its standard features and options.
- Other than selection of options, there are presently no significant design, parts, or operating differences among appliances with these model numbers.
- For further information, contact your Cleveland Range sales representative or Cleveland Range.

### B. Model Numbers and Serial Numbers

1. Cleveland Range, LLC assigns two product identification numbers to each appliance: a model number and a serial number.
2. Please provide this information when you contact Cleveland Range or a qualified Cleveland Range authorized service representative:

- Model Number \_\_\_\_\_  
(Write the Model Number of your appliance here)
- Serial Number \_\_\_\_\_  
(Write the Serial Number of your appliance here)

### C. Product Information Plate

The Product Information Plate on the back of the appliance lists:

- Model Number
- Serial Number
- Power Requirements
- Wiring Requirements

### D. Product Views

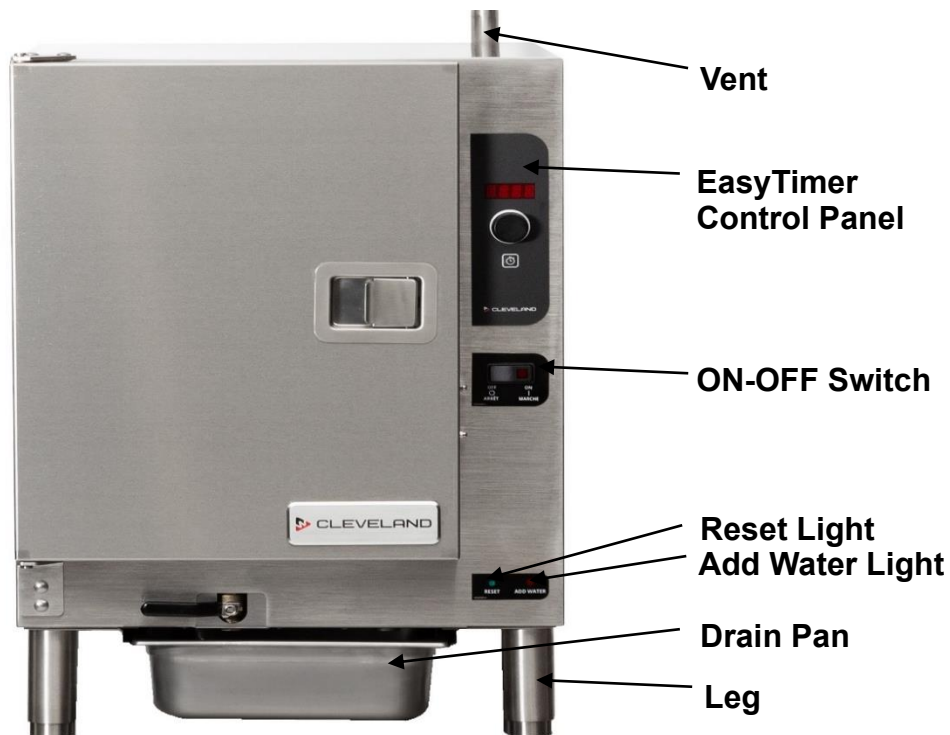

**Figure 2-1 Connectionless SteamChef™ Steam Cooker Front View  
(22CCT6)**

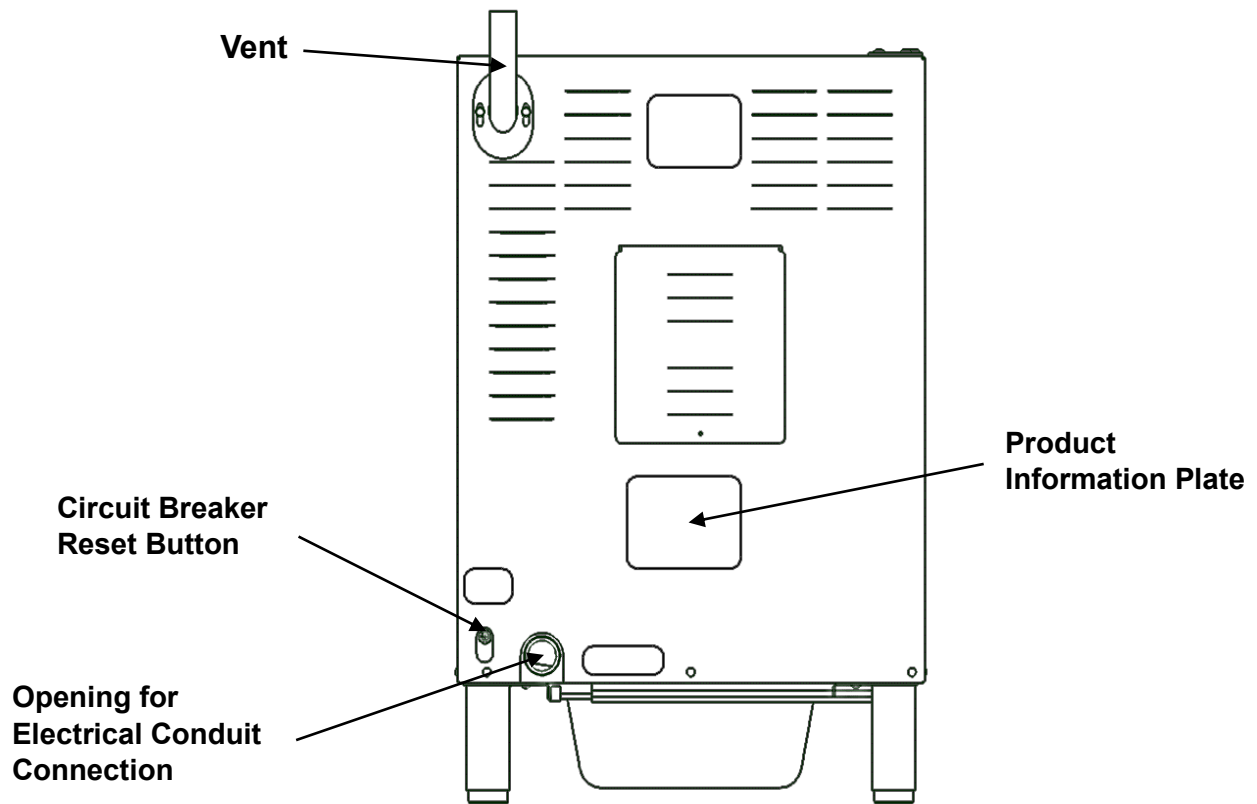

**Figure 2-2 Connectionless SteamChef™ Steam Cooker Rear View  
(Model 22CCT6)**

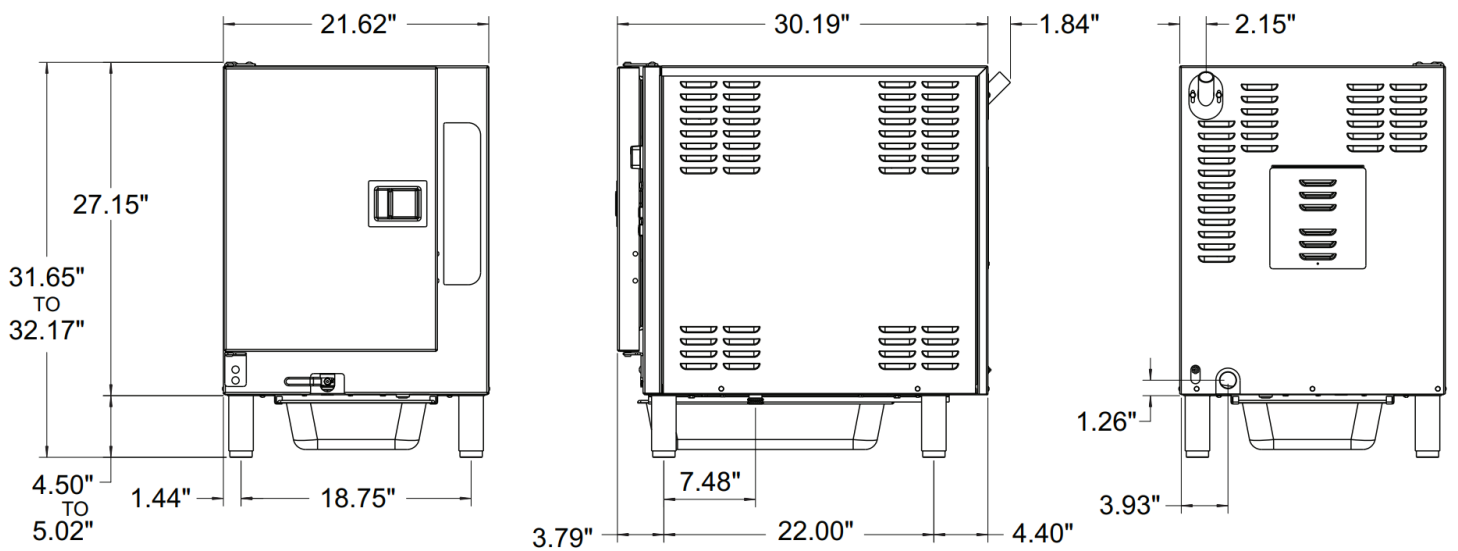

**Figure 2-3 Connectionless SteamChef™ – Front-, Right-Side-, and Rear View Dimensions  
(Model 22CCT6)**

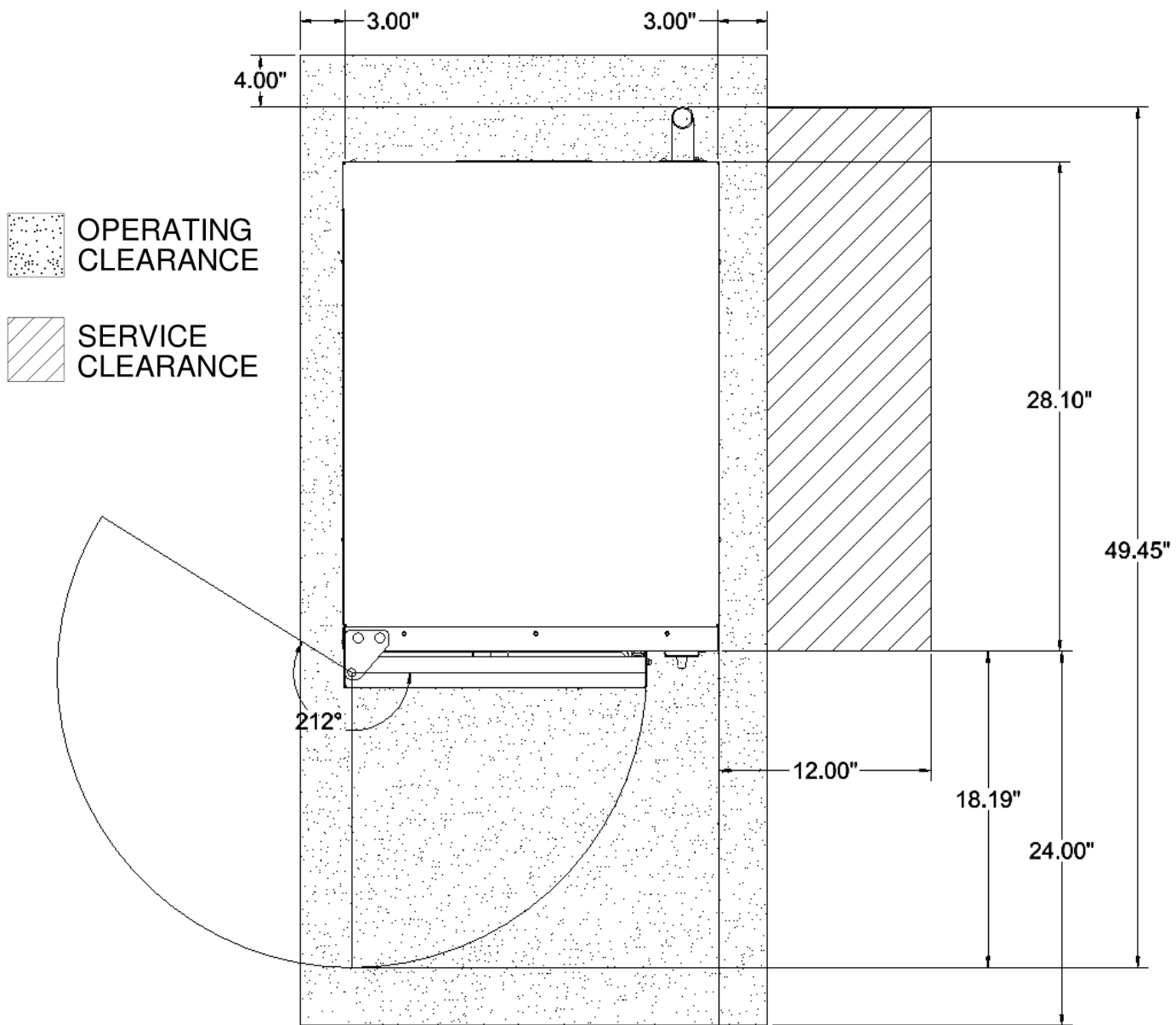

**Figure 2-4 Connectionless SteamChef™ – Top View Dimensions and Clearances (22CCT6)**

## CHAPTER 3 INSTALLATION PROCEDURE

### DANGER

Operating this appliance out of level can cause DEATH, INJURY, and EQUIPMENT DAMAGE. This appliance must be level both front-to-back and side-to-side in all installations.

NEVER operate this appliance out of level.

If this appliance is suspected to be out of level, shut it down at once and call your qualified Cleveland Range authorized service agency immediately.

#### A. Select a Location

For safe and efficient operation:

1. Installation must comply with all local fire and health codes.
2. The location selected must be capable of supporting this appliance.
  - The operating weight of a 22CCT6 is 265 pounds.
3. Position the appliance so it will not tip or slide.
4. The operating surface must be level enough to allow leveling with the adjustable legs. This appliance **MUST** be level both front to back and side to side before operation.
5. The location must include space for Operating and Service/Secondary Clearances and the vent. See Figure 2-4.

### WARNING

All clearance requirements above, below, and around this appliance are the same for non-combustible locations as for combustible locations.

Failure to maintain required clearances and additional distances as needed can result in INJURY and EQUIPMENT DAMAGE.

Consult manufacturers' literature, and sales and service agencies as needed.

7. KEEP THE APPLIANCE AREA FREE AND CLEAR OF COMBUSTIBLES.
8. Proper air supply for ventilation is REQUIRED for and CRITICAL to safe, efficient operation of this appliance.
9. Make sure the air vents of this appliance are not blocked with or by anything.
10. Allow for sufficient extra distance if a "high heat source," e.g., a broiler, is located next to this appliance. Contact Cleveland Range for recommendations.
11. Do NOT install this appliance directly over a drain. Steam rising up out of the drain will adversely affect operation, hamper cooling air circulation, and damage electrical and electronic components.

#### B. Installation of a SteamChef 22CCT6

### DANGER

Improper lifting can cause DEATH, INJURY, and EQUIPMENT DAMAGE.

Use enough workers with experience lifting heavy equipment to place the appliance on the supporting surface.

1. 22CCT's are typically installed with four adjustable legs.
2. The appliance must be level both front-to-back and side-to-side.
3. The operating surface must be level enough to allow leveling of the appliance using the adjustable legs of the appliance or the stand.
4. The counter area selected must be capable of supporting an operating weight of:
  - 265 pounds for the 22CCT6.

5. If a satisfactory counter location is not available, use an equipment stand:
  - UNISTAND 34 or UNISTAND 25 for one 22CCT6.
  - Model No. ES263044 Stacking Stand for two 22CCT6's, one on top of the other.

## ⚠ WARNING

Attempting to operate an improperly installed or out of level steamer or shifting the steamer while operating can cause injury and equipment damage.

Do NOT shift or move the steamer while it is operating.

Do NOT operate an improperly installed steamer. Use enough workers with experience lifting heavy equipment to place the appliance on the supporting surface.

### C. Position and Level

1. Move the appliance into position.
2. Using a level, adjust the legs of the 22CCT until it is level front-to-back and side-to-side.

### D. Install/Remove the Slide Racks (Pan Racks)

Each rack has four loops: two at the top and two at the bottom. See Figure 3-6.

1. Hold the slide rack so the ends of the hanger loops are toward the side of the cooking compartment.
2. Slide one rack into the compartment with loops toward one side.
3. Hook the loops over the top and bottom pins.
4. Repeat steps 1 to 3 for the other racks.

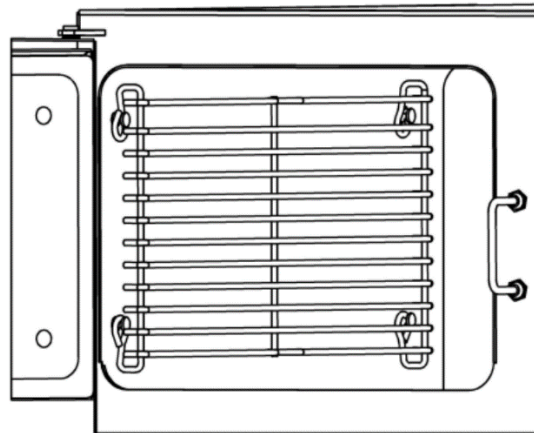

Figure 3-6 Slide Rack

### E. Install/Remove the KleanShield™

## ⚠ WARNING

Never operate a Connectionless Chef without the KleanShield™ properly installed. The properly installed KleanShield™ helps protect the operator from scalding water splashing out of the reservoir and helps prevent drain blockage. Operating a Connectionless Chef without the KleanShield™ properly installed can cause injury, equipment damage, and reduce performance.

- **Note:** The KleanShield™ is dishwasher safe.
- To **Install** the KleanShield™:
  1. Remove the pan racks.
  2. Place the KleanShield™ into the Connectionless Chef so the drain trough pipe slips into the drain pipe at the right side of the cooking compartment.

3. Carefully lower the front of the KleanShield™ so the Water Level Sensor Guard is behind the probes and the front legs rest on the bottom of the cooking compartment.
- To **Remove** the KleanShield™, turn off the Connectionless Chef and wait for it to cool, remove the pan racks, carefully lift the front of the KleanShield™, lift the drain trough pipe from the drain pipe, and remove the KleanShield™ from the cooking compartment

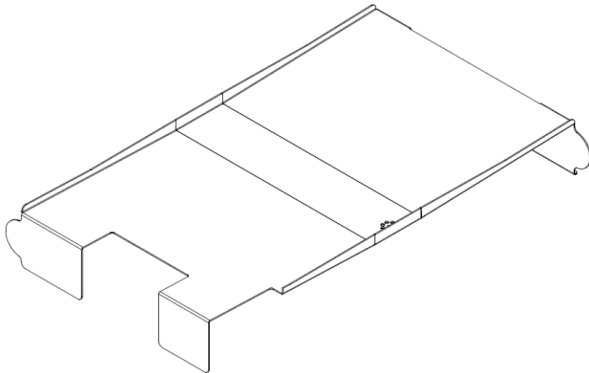

**Figure 3-6**  
**KleanShield™**



**Figure 3-7**  
**KleanShield™ Installation**

**F. Install the Fan Guard and Air Diverter**

1. Hold the fan guard so that the large ends of the keyhole slots are towards the bottom of the steamer.
2. Place all four large end openings of the keyholes over the mounts located on the rear wall of the steamer.
3. Pull it down so that the narrow ends of the slots are pulled tight over the mounts. See Figure 3-8.
4. Place the air diverter onto the fan guard as shown.

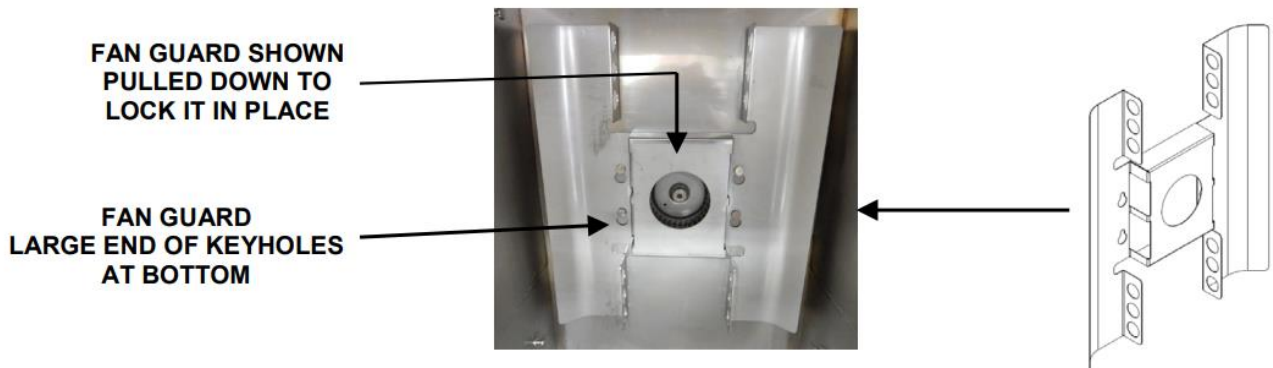

**Figure 3-8**  
**Fan Guard/Air Diverter Shown in Installed Position**

**G. Install/Remove the Bypass Shield**

**Note:** Bypass Shield should be installed when cooking with solid bottom pans.

- By Installing the Bypass Shield the Connectionless Chef will consume less water resulting in fewer reservoir refills during cooking.
- To Install/Remove, slide the Bypass Shield on the bottom Slide Rack (Pan Rack) slot so that it is just above the KleanShield™ as shown in Figure 3-9



**Figure 3-9**  
**Bypass Shield Installation**

## H. Electric Power Supply

- The electric supply must match all electrical and wiring requirements specified on the rating plate.
- **NOTE:** This appliance is NOT Ground Fault Interrupter (GFI or GFCI) compatible.
- The 22CCT6 Electrical Diagrams are located on the backs of the right side panel.

### **⚠ WARNING**

This appliance is not GFI (GFCI) compatible. Do not use a GFI (GFCI) circuit.  
Using a GFI (GFCI) circuit can result in INJURY, EQUIPMENT and PROPERTY DAMAGE.

The connection must be made as follows:

1. Install a main disconnect switch and a separate fuse or breaker for this appliance as shown in Figure 3-12. The fused disconnect switch is called the "Main External Power Switch."
2. Do not use a GFI (GFCI) circuit. This appliance is not GFI compatible.
3. **Do NOT use a power cord.**
4. Make the electrical connection using flexible conduit, per local code.
5. There should be a sufficient length of flexible conduit between the steamer and the wall so the appliance can be moved for service.
6. Mechanically secure the flexible conduit to the electrical access hole found at the rear of the appliance. See Figure 3-12.
7. Refer to the wiring diagrams and Figure 3-13. Connect the wires to the contactor, side control panel, and ground plug.
8. The appliance must be electrically grounded by the installer.

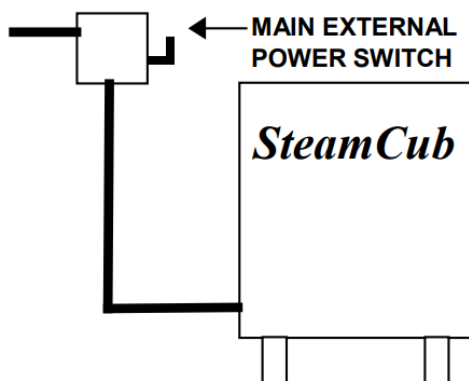

**Figure 3-12 Electrical Layout**



**Figure 3-13 Electrical Connection**

**I. Installation Checklist**

TASK		REFERENCE	COMPLETED
Preparation	Make Sure Electric Power Requirements are Met	Chapter 3 Section K	
	Check Operating Location Clearances	Chapter 2 Section D	
	Make Sure Location and Vent Requirements are Met	Chapter 3 Section A	
	Check Field Assembly of the 22CET	Chapter 3 Section B	
	Check Field Assembly of Stand (If Used)	Chapter 3 Section B	
Installation	Make Sure 22CET is Level	Chapter 3 Section D	
	Check Drain Pan Installation	Chapter 5 Section B	
	Check Electrical Line Connection	Chapter 3 Section K	
	Perform Operating Tests	Chapter 8 Section C	

## CHAPTER 4 COOKING WITH THE 22CCT6

### DANGER

Do NOT breathe steam, hot air or condensate. DEATH or INJURY will result.

### WARNING

**Hot air, steam, and condensate will cause burns and scalds.**

To help prevent burns and scalds when opening steamer doors: always stand to the hinge side and back from the doors, slowly open the door, and wait for the steam and heat to dissipate before reaching into the steamer.

**The SteamChef Steamer is a continuously operating appliance, so parts are ALWAYS HOT when the Main External Power Switch or the ON/OFF Switch is in the ON position.**

When the ON/OFF Switch is turned to the OFF position, the SteamChef will remain HOT for some time. Contact with hot surfaces and steam can cause burns and scalds. Avoid contact with hot surfaces and steam.

**If the steamer door is stuck shut: DO NOT force the door open.**

The door stuck shut may indicate a blocked drain. Hot water can fill the cooking compartment and spill out if the door is forced open causing injury and equipment damage.

If the SteamChef door is stuck shut:

- Turn OFF the steamer.
- Call a qualified Cleveland Range authorized service technician.
- Wait for the steamer to cool before servicing.

### CAUTION

**Some food drips juices.** Use a solid catch pan under perforated pans when cooking food that drips juices. Dripping juices can cause burns and clog the drain.

Do NOT use oven racks that are bent or damaged in any way.

DO insert pans and accessories LEVEL and INSIDE the oven racks.

Pans and accessories placed in damaged or out of level racks, or outside racks can tip and spill, causing burns, injuries and/or equipment damage.

#### A. Cooking Procedure:

**NOTE:** The condenser water does not flow until the cooking compartment reaches the minimum cooking temperature to reduce steam loss and condenser water use.

If condenser flow starts before the cooking compartment reaches cooking temperature, turn OFF the steamer and call your qualified Cleveland Range authorized service representative.

##### 1. Before Cooking or Rethermalizing

- a. Inspect the cooking compartment, drain, KleanShield™, and clean as required BEFORE turning ON the SteamChef. It will be too hot to inspect and clean safely after turning ON. See Chapters 3 and 7.
- b. Turn ON and fill the SteamChef. See Chapter 6.
- c. Preheat the cooking compartment. See Chapter 6.
- d. Slide the pans of food into the slide racks inside the SteamChef. Do not place pans or anything else on the bottom of the compartment or on the KleanShield™.
- e. For best results, use 2-1/2-inch-deep, perforated pans without covers. These give the best heat transfer and shortest cooking time.
- f. Close the cooking compartment door.

2. Refer to **Easy Timer Operating Instructions** in Chapter 5 to start cooking.
  - While cooking, occasionally check the water in the reservoir for food particles and oils. If the water is dirty or cloudy, change the water. See Chapter 9.
  - The steamer compartment of the SteamChef Steamer is equipped with an automatic **door interlock switch** that turns off the heating elements and shuts off the convection fan and condenser when the door to the compartment is opened.

## **WARNING**

### **BURN and SCALD HAZARD**

Even though the heat shuts off as soon as the door is opened, it may take up to a minute for production of steam to end and residual steam in the system to clear from the cooking compartment.

To help avoid injury, always wait until the residual steam clears and the convection fan stops before reaching into the cooking compartment, and always wear dry heatproof gloves when reaching into the cooking compartment. Wet or damp gloves conduct heat and can cause burns when touching hot items.

3. After Cooking or Rethermalizing
  - a) Carefully open the cooking compartment door and remove the pans from the slide racks.
  - b) If the SteamChef will not be used again, perform the **Cleaning Procedure** in Chapter 7.

### **B. Rethermalization:**

- The SteamChef may also be used to reheat/re-thermalize previously cooked and/or refrigerated foods to serving temperature.
- Depending on initial food temperature and density, most foods will rethermalize to their safe serving temperature in 10 to 40 minutes.
- Always check internal temperature of food with a thermometer to determine that it has been rethermalized to its safe serving temperature.

## CHAPTER 5 EASY TIMER OPERATING INSTRUCTIONS

---



DIGITAL DISPLAY

CONTROL KNOB

Enabled with **TIMED** mode

**TIMER START/STOP BUTTON** in **TIMED** mode

**TIMED/MANUAL SWITCH BUTTON**

(Press for 5 sec)



ON-OFF SWITCH

### **⚠ CAUTION**

Press switch and button with fingertips only.

**INJURY** and **EQUIPMENT DAMAGE** can result from pressing switches and buttons with anything else.

### A. Main External Power Switch

Usually, the Main External Power Switch is left ON.

To turn ON the Main External Power Switch:

- Turn the ON/OFF switch to the OFF position.
- Turn ON the Main External Power Switch. See Figure 5-1.

### B. Inspect the Cooking Compartment

1. Before every steaming operation, inspect the cooking compartments and remove any food scraps or debris. See Chapter 5.
2. Inspect the cooking compartment while the steamer is cold. After the steamer is turned on, it will be too hot to inspect or clean safely.
3. Before turning ON the power switch to the Connectionless Chef steamer make sure the inside of the steamer is clean. See Chapter 5 for complete cleaning instructions.
4. Remove the door gasket assembly, pan racks, fan guard, bypass shield, and KleanShield™ and make sure all surfaces are clean and drain openings and the water level sensors are clean and free of any residue or debris (See Figure 3-4).
5. Make sure there is an empty drain pan (4" X 12" X 20") in the drain pan rack and the KleanShield™ drain is clear by pouring about a quart of water through the KleanShield™ drain (See Figure 3-6 and 3-7). Make sure that the water flows out the steamer drain into the drain pan.
6. Inspect and clean the drain before each use. See Figure 3-5.

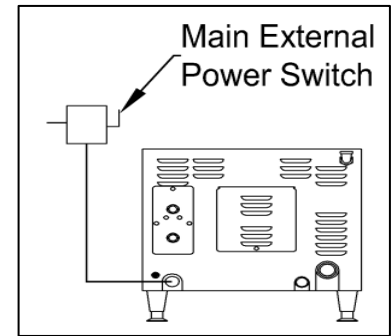

Figure 5-1

Main External Power Switch



Figure 5-2

Inspecting Compartment Drains

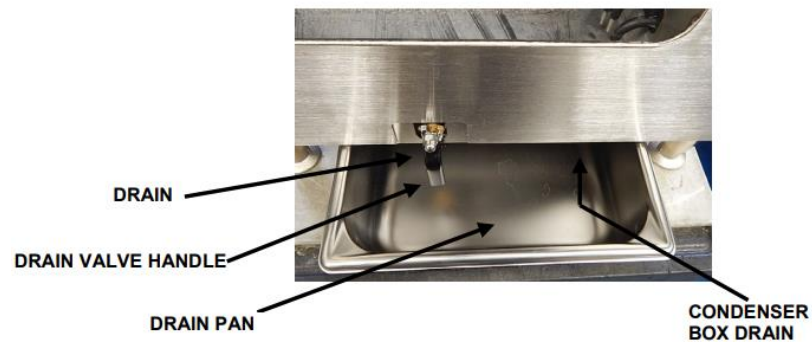

Figure 5-3

Drains and Drain Pan

### C. Manual Water Fill

- Do NOT use distilled water.
  - Fill with fresh water at least every day, at the start of every shift or more often as needed.
1. Before filling and turning on the appliance, make sure the cooking compartment is clean.
  2. Make sure the drain is clear and closed.
  3. Place an empty drain pan (4" X 12" X 20") in the drain pan rack.
  4. Add 3 gallons (until water level reaches just below KleanShield™) of fresh cold potable water to the bottom of the cooking compartment and pour 1 quart of water through the KleanShield™ drain.
  5. Add ¼ of a gallon in the Condenser Box.
  6. Check the water after every steaming operation and add water or, if the water has become dirty, drain and refill as needed.

#### D. Power ON

1. Turn the ON-OFF switch to ON. The digital display lights.
2. Switch to TIMED mode and set the timer to 10:00 and press the “TIMER-START/STOP” button.
3. Close the door.
1. Timed Mode (with “SURE COOK” mode feature)
  - a) Select cooking time using “Control Knob”.
  - b) Press “TIMER-START/STOP” button to start cooking.
  - c) “SURE COOK” illuminates on digital display once the compartment reaches 193°F (90°C).
  - d) Timer then starts to countdown until it reaches 00:00.
  - e) Steamer will stop heating and require prompt when the timer reaches 0:00.
2. Manual Mode (Continuous Steaming)
  - a) Press and hold “TIMER-START STOP” button for 5 seconds until switches to Manual mode.
  - b) “MAN” will appear on the digital display when activated and control knob disabled.
  - c) **NOTE:** steamer will go into “Standby” mode if compartment isn’t opened for 60 minutes.
3. Changing from Manual to Timed Mode
  - a) Press and hold “TIMER-START/STOP” button for 5 seconds until switching to TIMED mode.
  - b) “TIMED” will appear on the digital display.
  - c) Digital display will display 00:00, and the control knob will be activated.
4. “Descal” Notification
  - a) Easy Timer comes with 400 hours operation for “Descaling Notification.”
  - b) After 400 hours, “DESCALE” appears on digital display for 5 seconds and will re-appear every 5 minutes.
5. Reset and Clear Descal Notification
  - a) Turn OFF main power with POWER SWITCH.
  - b) Press and hold the “TIMER-START/STOP” button.
  - c) Power unit ON with main POWER SWITCH (with “TIMER START/STOP” Button held).
  - d) Wait 10 seconds to Reset/Clearing Mode.
  - e) The Beeper starts beeping once every second.
  - f) Release the “TIMER-START/STOP” button.
  - g) Display will show “RST”.
  - h) Press the “TIMER-START/STOP” button to confirm resetting descale notification.
6. Program Number of Hours until Descal Notification
  - a) Turn OFF main power with POWER SWITCH.
  - b) Press and hold the “TIMER-START/STOP” Button.
  - c) Power unit ON with main POWER SWITCH (with “TIMER START/STOP” button held).
  - d) Wait 20 seconds to enter Programming Mode (to change the Max number of hours)
  - e) The Beeper starts beeping twice every second.
  - f) Release the “TIMER-START/STOP” button.
  - g) Display will show past settings.
  - h) Turn knob to adjust the number of hours.
  - i) Press “TIMER-START/STOP” button to save number of hours for next descale notification.

## E. Preheat Steamer

Preheat steamer to ensure productivity and consistency. **BEFORE PREHEATING:** Inspect and clean the compartment. After preheating, the compartment will be too hot to inspect and clean safely.

### To preheat the SteamChef Steamer:

1. Close the steamer door and turn the steamer ON 15 minutes before cooking.
2. The steamer will heat to the standby temperature.

## F. High Limit Reset

This steamer has a high limit lockout to protect the unit from overheating.

### If the high limit lockout temperature is reached:

1. The RESET light will turn ON.
2. A buzzer will sound continuously.
3. The heater will shut OFF.
4. The steamer must be reset before cooking can continue.

### To reset the high limit:

1. Turn OFF power to the steamer with the ON/OFF switch.
2. Wait 15 minutes for the steamer to cool.
3. Make sure the water probes are clean.
4. Refill with water and restart according to the Power ON instructions (Chapter 5).
5. If the problem repeats, see the **Operators Troubleshooting Guide** (Chapter 9).

## G. Water Refill

- During operation, water level will slowly decrease.
- Once water level falls below the center probe, the Green “ADD WATER” indicator light will come on to let the user know to fill the reservoir.
- During this time, the Connectionless Chef will continue to cook until the water level reaches below the left probe. (Heat Probe)
- Once the water level is below the left probe (Heat Probe), a buzzer will sound and the Connectionless Chef will no longer cook until the reservoir is refilled with water. (Requires minimum of 2 gallons)
- To refill the compartment, pour fresh cold potable water into the slot shown in Figure 3-12

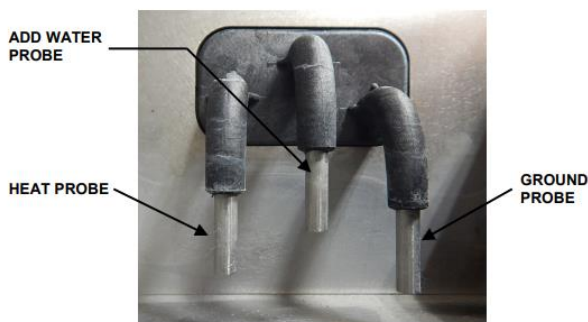

**Figure 3-11**  
**Water Level Probes**



**Figure 3-12**  
**Water Refill Location**

## CHAPTER 6 SHUTDOWN AND CLEANING PROCEDURE

### WARNING

**The steamer stays hot for a long time.** To help avoid burns, allow the steamer to cool completely before cleaning or servicing.

**Do NOT use hoses, power cleaners, or pressure washers on or in the SteamChef Steamer.** Doing so can cause electric shock and/or damage electrical and electronic components.

**A clogged or slow drain can cause hot water to collect in the oven compartment and spill out when the door is opened causing injury and equipment damage.**

Never push food debris or scale down the steamer drain, or through the KleanShield™ opening. Debris and scale can build up in the drain system and clog or slow the drain and lead to additional maintenance and service problems.

Always remove any solid matter from the inside of the steamer with a rag or spatula before rinsing cleaning water down the drain.

### WARNING

**When cleaning: do NOT pick up or tilt the SteamChef.** If it is necessary to move a SteamChef for cleaning, turn OFF power at the Main External Power Supply and at the ON/OFF switch to drain the water from the SteamChef.

**INJURY and EQUIPMENT DAMAGE can result from shifting the SteamChef out of level while the power is ON at the Main External Power Supply and/or water is in the SteamChef.**

The steamer MUST BE LEVEL BOTH FRONT TO BACK AND SIDE TO SIDE in all mounting arrangements before operation. Check level front to back and side to side before restoring power as described in the Installation Manual after moving the SteamChef.

#### Cleaning Procedure

1. Turn OFF the ON/OFF Switch.
2. Open the cooking compartment doors and allow the appliance to cool.
3. Make sure an empty drain pan (4" X 12" X 20") is in the drain pan guides and drain the steamer by turning the drain handle to the drain position.
  - The drain pan should have the front edge pulled out just enough, so that the drain empties fully into the drain pan. Having the drain pan pushed back too far into the rack or pulled out too far from the rack can cause spilling or tipping of the drain pan.
4. Remove any spilled food from the surface of the KleanShield™ and Bypass Shield.
  - Never push food scraps down the KleanShield™ opening or the reservoir drain opening.
5. Remove the slide racks, fan guard, Bypass Shield, and KleanShield™ Wash and rinse slide racks, fan guard and KleanShield™ separately or clean them in a dishwasher according to health requirements.
6. Remove any spilled food from inside compartment and clear any residue from the drain valve and the KleanShield™ drain opening.
  - Do not push food debris or scale down the steamer drain, or through the KleanShield™ drain.
7. Clean the interior of the compartment thoroughly, removing all food particles and scale from the steamer.
8. Wipe down the interior of the cooking compartment with a half water and half white household vinegar solution. Use a spray bottle of the same vinegar solution to rinse the convection fan located at the back of the cooking compartment.
  - When done daily this will help prevent the buildup of calcium and other mineral deposits left over from the boiling of water, and prevent scale buildup in the steamer, helping prevent more costly maintenance and service on the steamer.
  - Cleveland Range does not recommend the use of detergent, but if detergent has been used to clean the

inside of the steamer, be sure to rinse off the probe assembly with the vinegar solution. If detergent residue is not completely rinsed from the probe assembly, then the residue can prevent the water level control from operating.

9. Use a soft bristle brush to clean the water sensor, temperature probe, and fan and to remove stubborn food particles.

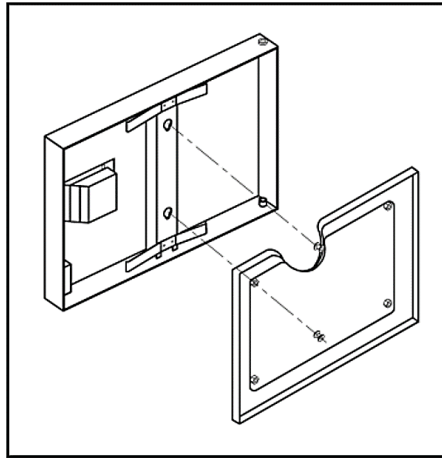

**Figure 6-1**  
**Door Gasket Assembly**

10. Do not use abrasive cleaning compounds or steel wool.
11. Rinse the inside of steamer compartment and drain valve thoroughly with clean water.
12. Inspect the probe assembly and clean it with a soft bristle brush or similar non-abrasive cleaning means.
13. Clean the door assembly.
14. Replace the cleaned KleanShield™ slide racks and fan guard. (See Chapter 3.)
15. Wipe the exterior with a damp cloth only.
16. NEVER HOSE DOWN THE STEAMER. Electrical components inside the unit will not function correctly if wet or damp and may cause a shock hazard.
17. After cleaning, leave the steamer door open until the next steamer operation. This prevents compartment odor buildup and helps increase gasket life.

## CHAPTER 7 OPERATING TESTS AND FINAL CHECKOUT PROCEDURES

- **This procedure must be performed by a qualified Cleveland Range authorized service representative.**
- Complete the Startup Procedure before starting the actual operating tests.
- Read and understand all steps of this procedure before starting.
- This procedure evaluates the function of the major operating controls of a SteamChef.
- This procedure is for SteamChefs equipped with an Easy Timer control panel.
- For high altitude use (above 3500 feet), contact Cleveland Range about parts and adjustments required.

### A. Startup Procedure

1. Set the ON/OFF Switch to OFF and open the steamer door. There should be no water in the steamer.
2. Make sure that the KleanShield™ and reservoir drains are clear. See Figure 3-3.
3. Check for proper installation of the KleanShield™, fan guard, backplate, slide racks (See Figure 3-5), and door gasket assembly.
4. Make sure the Main External Power Switch is OFF.
5. Make sure the fuses or breakers are the proper size.
6. Remove the control side access cover.
7. Check the internal wiring and make sure there are no loose or disconnected wires.
8. Make sure the supply wiring is the correct size.
9. Check that the appliance is properly grounded.
10. Correct any deficiencies.

### B. Operating Tests and Final Checkout Procedure

**NOTE:** Temperatures need to be adjusted for high altitude use (above 3500 feet). Contact Cleveland Range about parts and adjustments required.

**NOTE:** Make sure the KleanShield™, Fan Guard, and drain pan are installed prior to testing.

1. Turn ON the Main External Power Switch.
2. Turn ON the ON/OFF switch.
  - The control panel energizes, the Green “ADD WATER” indicator light turns ON, and the buzzer sounds continuously.
  - Add 3 quarts of fresh water to the reservoir. (Do NOT use distilled water.) The Add Water buzzer will turn OFF.
  - Add an additional 2 ¼ gallons of fresh water to the reservoir. (Do NOT use distilled water.) The Green “ADD WATER” indicator light will turn OFF.
  - The “ADD WATER” alarm and indicator will turn ON whenever the water level drops below the water sensors located at the lower right front of the steamers interior. (See Figure 8-1).
3. Set the controls:
  - ON/OFF switch: ON (The digital display is on).
  - TIMED/MANUAL mode: TIMED.
  - Timer: 00:00.
  - Door: Open.

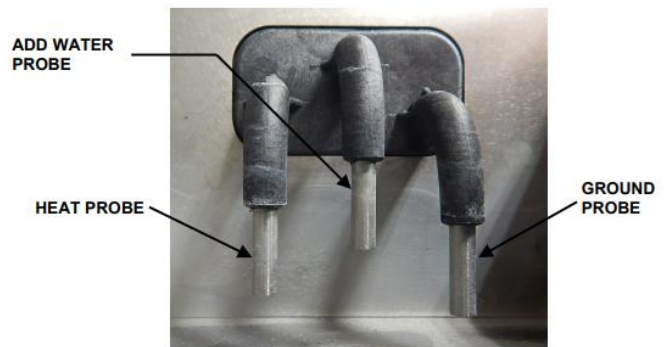

**Figure 8-1**  
**Water Level Probes**

4. Set the TIMED/MANUAL switch to MANUAL.
  - Nothing will happen as long as the door is open.
5. Close the steamer door, the steaming cycle starts.
6. Check the following functions.
  - The door interlock switch makes contact.
  - The heating elements are energized.
  - The water in the steam generator reservoir boils in a few minutes.
  - Steam is visible intermittently coming from the steam vent (the small pipe extension at the right rear on the steamer's back).
  - The cooking compartment reaches cooking temperature, and the heating elements cycle on and off as the thermostat maintains cooking temperature.
  - In Manual mode, the appliance will cook continuously until turned off, or set to the Timed mode.
  - After several minutes of steaming, check for steam leaks around the door gasket.
7. Set the TIMED/MANUAL switch to TIMED and timer to 00:00.
  - The steam generating cycle stops.
  - The heating elements turn off.
8. Open the cooking compartment door for 3 minutes to allow the cooking compartment to cool.
9. After 3 minutes, close the door and continue testing.
10. Set the TIMED/MANUAL to TIMED, and set the Timer for 10 minutes.
11. As soon as the "TIMER-START/STOP" button is pressed, the steam generating cycle starts.
  - This is the same sequence as Manual operation except:
    - The timer controls the cycle.
    - The elapsed time to produce steam is shorter because the water in the steam-cooking compartment is already hot.
12. After the timed operation has been started, observe the following steam generating functions.
  - The timer immediately begins counting down to zero.
  - Check for steam leaks around the door.
  - When the timer counts down to zero, the heating elements, and the buzzer sounds for 3 seconds.
13. Turn the ON/OFF switch OFF.
14. Turn the steamer off at the Main External Power Switch.
15. Replace the side panel.
16. After completing the Initial Startup Procedure, the Operating Test procedure and the Steam Shut Off Test procedure, the steamer is ready for use.

# CHAPTER 8 PREVENTIVE MAINTENANCE

---

## A. Maintenance

Maintenance on the steamer must be performed on a regular basis to keep it running properly and efficiently. By following the maintenance instructions in this chapter and cleaning the equipment regularly as outlined in Chapter 7, problems with the steamer will be kept to a minimum. The frequency of steamer maintenance may need to be increased, depending on equipment usage and water quality. If problems occur, refer to the **Troubleshooting Guide**. For more information on product and services, contact your sales representative.

### 1. Maintenance Records

Make a file for maintenance and repair records only. Keep a written record of daily, weekly, monthly, and yearly maintenance. These records will help protect warranty coverage, help schedule maintenance procedures, help keep the SteamChef cooking properly, and assist service personnel.

### 2. Daily Maintenance

#### a) Checking and Changing Water

When using the SteamChef Steamer frequently check the water, especially if cooking with perforated pans. Although most food drippings will be caught by the KleanShield™, the water may become dirty from spills falling over the edge of pans when loading, cooking, and emptying the steamer. Change the water (see below) when the water becomes cloudy or contaminated with food particles.

## NOTICE

**Change the water in the SteamChef steamer at least every day to maintain food quality and keep the steamer sanitary.**

It may be necessary to change the water several times a shift, especially if cooking strong-flavored foods or using perforated pans.

#### b) To Change the Water in the Reservoir:

- i. Turn the ON/OFF switch to OFF to de-energize all controls and drain the steamer. Wait 3 minutes to allow drain cycle to complete.
- ii. Open the steamer door and allow steamer to cool.
- iii. Remove the KleanShield™. Remove any food particles and rinse the KleanShield™ with clean water.
- iv. Remove any spilled food from inside compartment and rinse any residue from the drain valve and the KleanShield™ drain.
- v. Replace the KleanShield™. See Chapter 3.
- vi. Manually fill water to the normal operating level and turn on the ON/OFF switch.
- vii. Close the door. The “SURE COOK” message will appear, and the steamer will begin to automatically heat the water supply to the standby cooking temperature.
- viii. When the “SURE COOK” message turns OFF, the steamer is ready to begin cooking.

#### c) Cleaning the Steamer

Clean interior and exterior of the steamer according to the Shutdown and Cleaning Instructions in Chapter 6 at least once a day or at the end of each shift.

## B. Descaling Water Reservoir

**Only qualified Cleveland Range authorized technicians or trained onsite maintenance personnel may perform this procedure.**

### 1. Is Descaling Necessary?

- a) Although a SteamChef should not normally require this procedure, the use of “hard” water or failure to follow the cleaning procedures in Chapter 6 may cause the accumulation of scale in the SteamChef.
- b) Scale can deposit in the bottom of the SteamChef reservoir and/or in its drain. Descaling can help prevent a costly service call if scale buildup begins to impair the SteamChef’s operation.

- c) Descaling is not normally required on a SteamChef. Frequency will depend on water quality, and the frequency of shutdown and cleaning of the water reservoir.
  - d) The frequency of descaling must be determined by the owner and performed by qualified Cleveland Range authorized technicians or trained onsite maintenance personnel.
2. If descaling is necessary, Cleveland Range recommends the use of DISSOLVE® Descaler Solution, Cleveland Range Part No. 106174. No other system of descaling should be used.
 

**NOTE:** Part No. 106174 is the part number for a case (6 1-gallon containers) of DISSOLVE® descaler.
  3. Follow the instructions included with the DISSOLVE® Descaler Solution. Call Cleveland Range at 216-481-4900 or 1-800-338-2204 if there are any questions.

**MODEL 22CCT6 CONNECTIONLESS STEAMER DESCALING PROCEDURE (For DISSOLVE® Descaler Solution P/N 106174)**

- The entire procedure must be read and fully understood before beginning descaling.
  - This procedure takes about 1 hour 30 minutes to complete.
  - Repeat this procedure as needed for heavy scale buildup.
  - Regular cleaning of the steamer with vinegar per the instructions found in the Shutdown and Cleaning Instructions may help reduce need for descaling. See Chapter 6.
  - Sides, back, and top of steam compartments may be descaled with a vinegar solution and a soft brush. See Chapter 5.
1. Turn OFF the ON/OFF Switch.
  2. Open the cooking compartment doors and allow the appliance to cool.
  3. Make sure an empty drain pan (4" X 12" X 20") is in the drain pan guides and drain the steamer by turning the drain handle to the drain position.
  4. The drain pan should have the front edge pulled out just enough, so that the drain empties fully into the drain pan. Having the drain pan pushed back too far into the rack or pulled out too far from the rack can cause spilling or tipping of the drain pan.
  5. Remove the Pan Racks and KleanShield™ from inside the steamer.
    - Heavily scaled pan racks and KleanShield™ may be descaled by soaking them in a solution of 1 part Dissolve® and 4 parts water, rinsing thoroughly with cold water, and washing them in a dishwasher.
  6. Remove any loose scale from the bottom of the steamer.
  7. Leave the Connectionless Chef OFF and the door open.

**NOTE: DO NOT HEAT THE STEAMER DURING DESCALING.**

8. Pour 1 to 1 ½ quarts (about a third of a 1-gallon bottle) of DISSOLVE® descaler solution into the water reservoir.
  - While adding DISSOLVE® descaler to the reservoir, pour it in slowly to avoid splashing the liquid or overflowing the reservoir.
9. After, fill the reservoir with water to the level the Connectionless Chef normally operates.
10. Leave the door open and let the DISSOLVE® work for 1 hour.
11. At the end of 1 hour, drain the reservoir.
12. Refill the reservoir with water just above the normal operating level (just over 3 gallons) and drain again.
13. After the reservoir drains, refill with water to normal level (3 gallons) and turn ON the ON/OFF Switch.
14. Set the TIMED/MANUAL Switch to TIMED, close the cooking compartment door, and set the timer for 20 minutes. The steamer heats to normal operating temperature.
15. After 20 minutes turn OFF the ON/OFF Switch and drain the reservoir.
  - This is the final rinse of the reservoir.

## DANGER

The liquid solution in Cleveland Range Descaler Solution Part No. **106174** can be harmful if not handled properly. Follow these basic safety rules for handling and using this product. Instructions and warnings on container labels supersede all other warnings and instructions.

Wear protective clothing when mixing or applying chemical cleaners.

Wear rubber gloves, and OSHA approved eye protection when descaling

Avoid breathing fumes.

If liquid contacts skin: wash with soap and water.

If chemical contacts eyes: flush with water and seek medical attention.

If chemical is swallowed or ingested: drink 1 or 2 glasses of water and seek medical attention.

**Failure to do so can cause DEATH or INJURY.**

## CAUTION

Do not use any other product or method of descaling other than the DISSOLVE® Descaler method using part number **106174**.

**Failure to do so can cause DEATH or INJURY.**

## CHAPTER 9 TROUBLESHOOTING GUIDE

The Troubleshooting Guide is a list of symptoms of problems that may occur during routine operation.

- “Problem” (left column) lists common operating problems.
- “Possible Cause” (center column) lists causes of problems in the order they should be checked.
- “Remedy / Reference” (right column) lists fixes for problems from easiest to hardest.
- “Notes” in “Remedy / Reference” column are at end of the Troubleshooting Guide.

**ATTEMPTING TO REPAIR OR CORRECT PROBLEMS REQUIRING A QUALIFIED CLEVELAND RANGE AUTHORIZED SERVICE REPRESENTATIVE VOIDS THE WARRANTY.**

PROBLEM	POSSIBLE CAUSE	REMEDY/REFERENCE
Digital display does not turn ON when ON/OFF switch is in the ON position.	Power turned OFF at Main External Power Switch.	Turn ON power at Main External Power Switch.
	Inoperative controls.	See Note 1.
Digital display turns ON and steamer does not heat to cooking temperature or produce steam.	Door interlock switch not engaged.	Close door completely.
	Appliance is in Timed Mode and timer is not set.	Change to Manual Mode or set the timer.
	High limit switch has been tripped.	Reset steamer. See Chapter 3. If condition repeats, see Note 1.
	Bottom of reservoir is heavily scaled.	See Note 1 or 9.
	Inoperative controls.	See Note 1.
Steam and/or water leaking around the compartment door.	Water level too high	Drain excess water.
	The drain to the KleanShield™ opening is clogged or covered.	Clear collector openings. If condition persists see Note 1.
	Door gasket or door parts worn.	See Note 1.
	Appliance not level.	See Note 2.
ADD WATER Indicator light is ON, but steamer is filled with water.	Sensor is dirty.	Clean water sensor.
	Distilled water used to fill steamer.	Water sensor may not work with distilled water. Use non-distilled water.
	Inoperative controls.	See Note 1.
Compartment bottom dirty with food drippings.	Juices and/or food leaking from pans.	Put a solid pan under perforated pans to catch drippings. Put less food in pan.
	KleanShield™ not installed.	Install KleanShield™.
Food takes too long to cook.  <b>To verify the steamers proper operation see Note 8.</b>	Pans too close to the bottom of cooking compartment.	Put pans in racks near top of cooking compartment.
	Compartment overloaded with too much food.	Put less food into pan. Use fewer pans.
	Suggested cooking times are usually listed for cooking at sea level.	Extend cooking times for altitudes above 2500 feet.
	Convection fan inoperative	See Note 1.
	Bottom of steamer is scaled.	See Note 9.
	Voltage too low for unit.	See Note 5.
Easy Timer display has noise/disruptions.	Power surge/not clean power.	Recommended power surge bar to resolve rare EMI/power disruptions.

Digital display is on, controller is not lit and alarm sounds continuously.	Hi limit has been tripped.	Turn OFF power for 5 minutes and back ON. If problem repeats itself, see Note 1.
Steam coming out of the exhaust.	A small amount of steam may issue from the exhaust, every time the elements are cycled in the cooking mode.	This is normal operation of the steamer NO action is necessary.
	Inoperative thermostat or controls.	See Note 1.
Easy Timer button does not respond	If EasyTimer display is ON, then the button membrane is broken.	See Note 1.
	If EasyTimer display is OFF, then wiring has been damaged.	See Note 1.

### TROUBLESHOOTING NOTES

1. If the problem is inside the appliance, call a qualified Cleveland Range authorized service representative or Cleveland Range. (Please have the model number and serial number ready when calling.) Cleveland Range will not pay for warranty repairs by unauthorized maintenance and repair centers.
2. Proper installation of the appliance is the responsibility of the Owner-User. Refer to the Warranty.
3. Repairs to external plumbing must be done by a Licensed Plumber.
4. To restart the unit, follow the Lighting (Start-Up) instructions in this manual.
5. Repairs to external wiring must be done by a Licensed Electrician.
6. For more information on products and services, contact your nearest Authorized Sales Representative.
7. Call the factory for a preventative maintenance program, descaling information, and water treatment systems.
8. Use the Egg Test to evaluate steamer performance.

**NOTE:** this test is not valid for pressure steamers.

- a) Turn on the steamer and set to MANUAL mode.
- b) Preheat the steamer for ten minutes.
- c) After the compartment is preheated, place a fresh egg on a perforated steam table pan in the middle of the cavity.
- d) Close the door and set the timer as directed by the size chart below:

Egg Size	Time
Medium	12 minutes
Large	14 minutes
Extra Large	14 minutes

- e) Carefully remove the egg and place in a container with cold water running over it.
  - f) Let cool under cold running water for 5 minutes.
  - g) After cooling, crack eggshell and peel.
  - h) A properly operating steamer produces a perfect hard-boiled egg.
9. Whenever opening door, especially when water or steam is leaking around the gasket, heed the warning below:

## **WARNING**

### **Burn, Scald and Equipment Damage Hazard**

If the drain is blocked, hot water can fill the cooking compartment and spill out when the cooking compartment door is opened.

Signs of blocked drains include steam or water leaks around the cooking compartment door, and reduced cooking performance.

To help avoid injury:

- Stand on the hinge side and away from the appliance and slowly open the cooking compartment door.
- Inspect the drain(s) before each use and clean them if needed.

Failure to follow these precautions can cause BURNS, SCALDS, and EQUIPMENT DAMAGE.

10. Although a Connectionless Chef Steamer normally should not require descaling, the use of extremely “hard” water or failure to follow the cleaning procedures in the Shutdown and Cleaning Instructions may cause scale buildup. Have Cleveland Range authorized technicians or trained onsite maintenance personnel descale the steam.

# Cleveland

Cleveland Range, LLC  
760 Beta Drive, Unit D  
Mayfield Village, Ohio 44143  
216.481.4900  
800.338.2204

---

---

Every new piece of Welbilt Foodservice equipment comes with KitchenCare® and you choose the level of service that meets your operational needs from one restaurant to multiple locations

**StarCare** – Warranty & lifetime service, certified OEM parts, global parts inventory, performance audited

**ExtraCare** — CareCode, 24/7 Support, online/mobile product information



To learn how Welbilt Foodservice and its leading brands can equip you, visit our *global* web site at [www.welbilt.com](http://www.welbilt.com), then discover the regional or local resources available to you.