

# PARTS MANUAL

---

PATENT PENDING

22CGT6

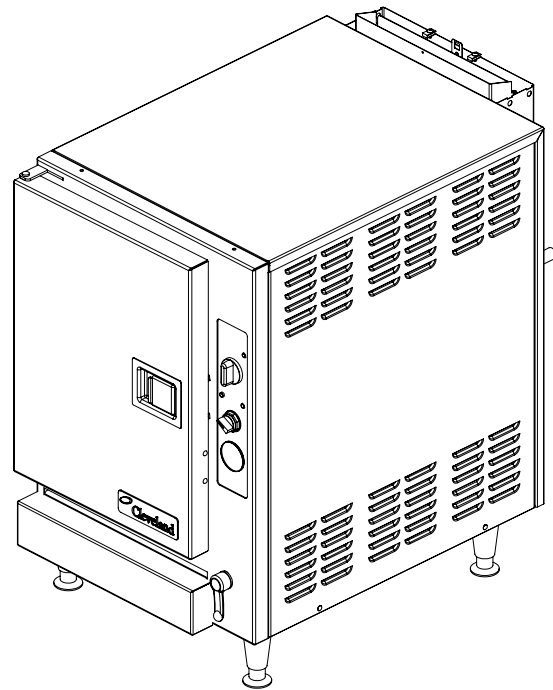
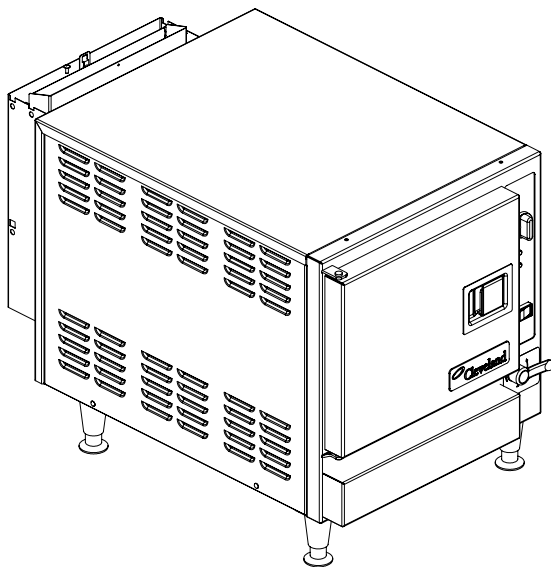

22CGT3

---

**Series: SteamChef™ Models 22CGT3 and 22CGT6**

---

1333 East 179<sup>th</sup> Street  
Cleveland, Ohio 44110

Phone: (216) 481-4900  
Fax: (216) 481 3782  
[www.clevelandrange.com](http://www.clevelandrange.com)



260BAZ REV. A JULY 2007



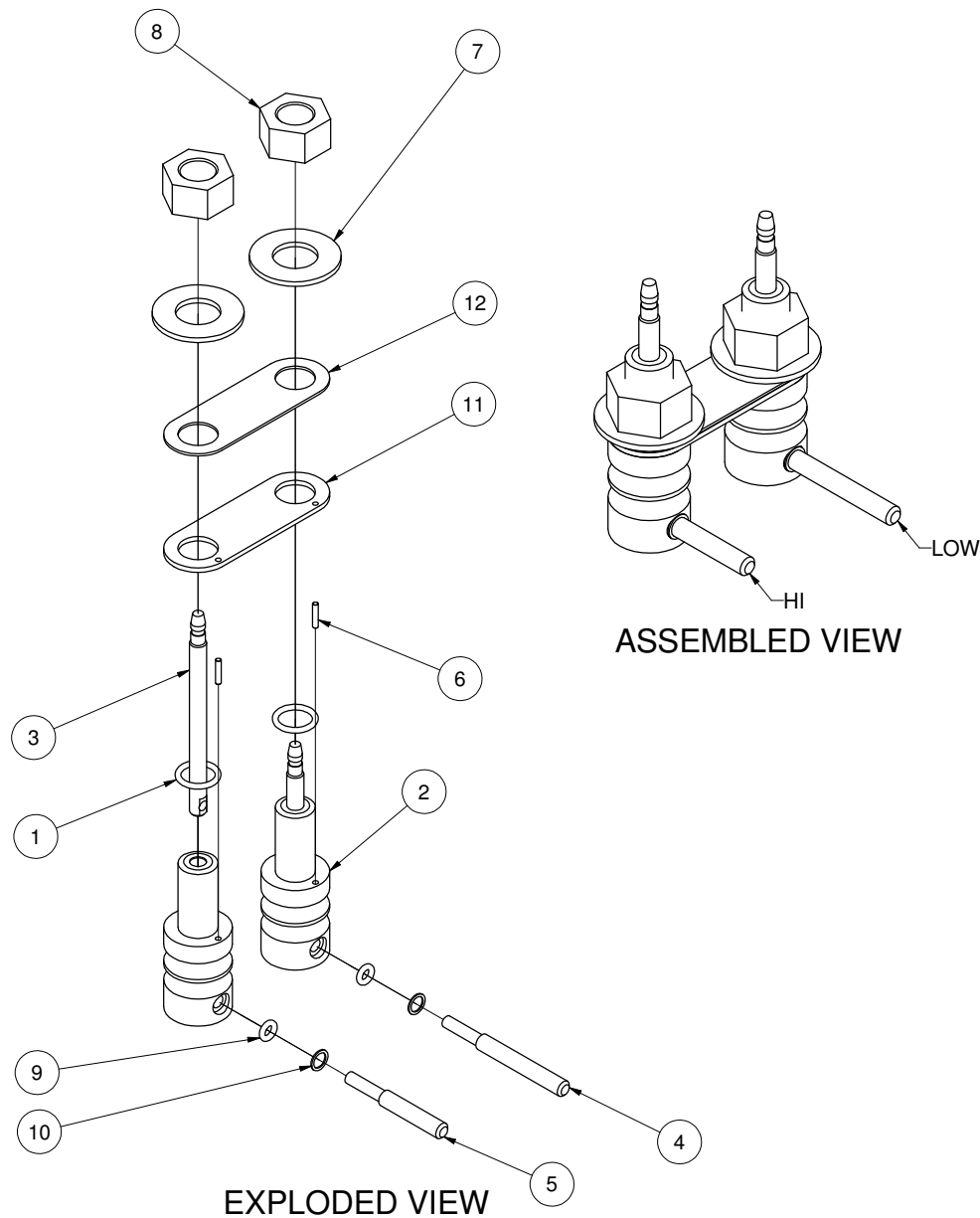

LET.	DESCRIPTION	DATE	BY
B	DRAWING RELEASE, PER EO# C-8700R1	9-13-04	VDS
C	UPDATE PRODUCT STREAM DATA "PER ECR-07-177"	04-25-07	LPH
D	UPDATE PRODUCT STREAM DATA "PER ECR-07-181"	04-25-07	LPH

12	1	111317	GASKET, LOCK PLATE, PROBE
11	1	111308	PLATE, LOCK/POSITION, PROBE
10	2	111321	WASHER, FLAT, 0.143 ID X 0.267 OD, 316 SS
9	2	111322	O-RING, 0.125 I.D. X 0.0250 O.D., SILICON
8	2	111313	NUT, HEX, 7/16-20 NYLON
7	2	111452	WASHER, FLAT, ID 0.500, OD 1.003, THK. 0.062, TEFLON
6	2	111453	PIN, DOWEL, 1/16 X 5/16, 304 SST
5	1	111310	PROBE EXTENSION, (HI)
4	1	111311	PROBE EXTENSION, (LOW)
3	2	111312	ROD, PROBE CONNECTION
2	2	111309	BUSHING, PROBE
1	2	109964	SEAL, O-RING, 0.375 I.D. X 0.500 O.D.

ITEM	QTY	PART NO.	DESCRIPTION
<b>CLEVELAND RANGE, LLC</b> 1333 East 179th St., Cleveland, Ohio 44110-2574 <small>THIS DESIGN DESCRIBES A PROPRIETARY ITEM AND IS THE PROPERTY OF CLEVELAND RANGE. THIS DRAWING IS NOT TO BE COPIED OR USED WITHOUT THE APPROVAL OF CLEVELAND RANGE.</small>			
<small>TOLERANCES (UNLESS OTHERWISE NOTED)</small> DECIMAL $\pm 0.030$		<small>DO NOT SCALE PRINTED DRAWING</small>	<small>DRAWN BY</small> VDS <small>DATE</small> 9/8/2004
<small>ANGULAR</small> $\pm 1^\circ$		<b>ASSEMBLY, PROBE, DUAL LEVEL, HL</b>	
		<small>SIZE</small> B <small>DRAWING NO.</small> 3003231	<small>SHEET 1 OF 1</small> <small>REV</small> D

LET.	DESCRIPTION	DATE	BY
A	PRODUCTION RELEASE "PER ECR-07-209"	05-04-07	LPH
B	PICTORIAL UPDATE ITEM 1 "PER ECR-07-257"	06-08-07	LPH

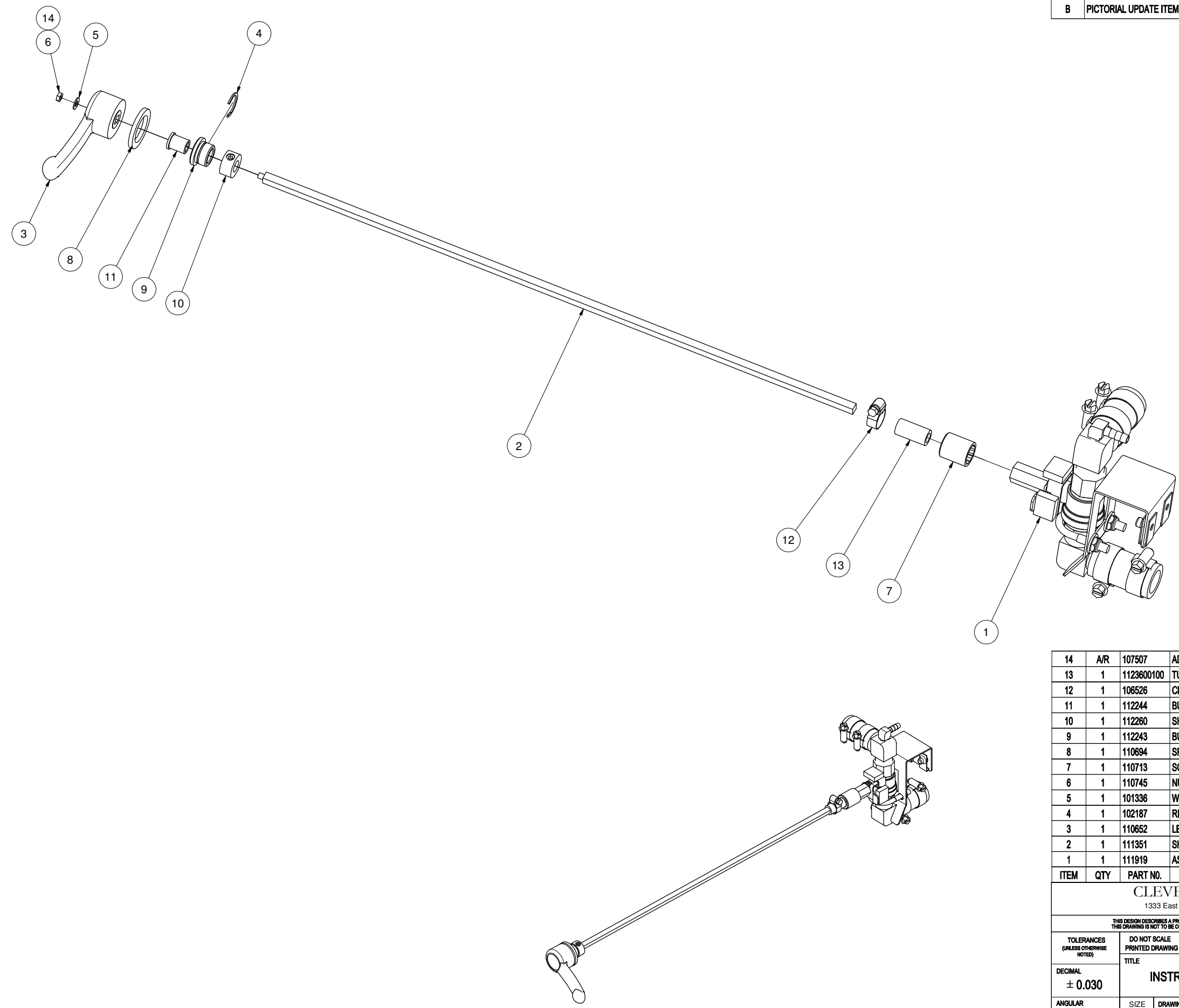

14	A/R	107507	ADHESIVE, LOCTITE BLUE, THREAD LOCKER 242
13	1	1123600100	TUBE, NEOPRENE, 5/16"ID x 1"LG
12	1	106526	CLAMP, HOSE, WORM DRIVE, 3/8 TO 5/8x5/16W, SST
11	1	112244	BUSHING, INSERT
10	1	112260	SHAFT COLLAR
9	1	112243	BUSHING, SUPPORT, GEMINI
8	1	110694	SPACER, CONTROL LEVER STEAMCHEF 3
7	1	110713	SOCKET, 1/4" DRIVE, 9/16" 12 POINT
6	1	110745	NUT, HEX, 8-32 SMALL PATTERN, 1/4", SST
5	1	101336	WASHER, FLAT, #8, SST
4	1	102187	RING, RETAINING, .688 CRESCENT, J STEAMER
3	1	110652	LEVER, CONTROL
2	1	111351	SHAFT, KNOB/VALVE CHEF 3,6 GAS
1	1	111919	ASSEMBLY, PIPING, DRAIN/POWER, ON/OFF, HL
ITEM	QTY	PART NO.	DESCRIPTION

<b>CLEVELAND RANGE, LLC</b> 1333 East 179th St., Cleveland, Ohio 44110-2574			
THIS DESIGN DESCRIBES A PROPRIETARY ITEM AND IS THE PROPERTY OF CLEVELAND RANGE. THIS DRAWING IS NOT TO BE COPIED OR USED WITHOUT THE APPROVAL OF CLEVELAND RANGE.			
TOLERANCES (UNLESS OTHERWISE NOTED)	DO NOT SCALE PRINTED DRAWING	DRAWN BY <b>LPH</b>	DATE <b>4/25/2006</b>
TITLE <b>INSTRUCTION, PIPING, DRAIN/POWER ON-OFF</b>			
DECIMAL <b>± 0.030</b>	SIZE <b>C</b>	DRAWING NO. <b>1119191</b>	SHEET 1 OF 1 <b>B</b>

NOTE:  
 1) USE ONLY TEFLON TAPE, DO NOT SUBSTITUTE ANOTHER MATERIAL.

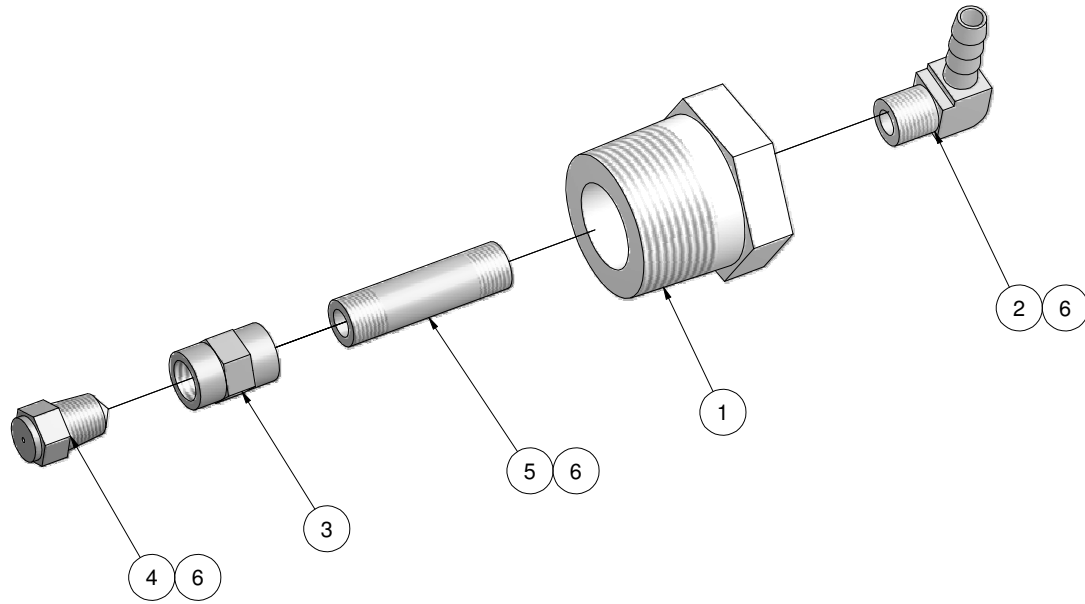

LET.	DESCRIPTION	DATE	BY
A	PRODUCTION RELEASE PER ECR-07-172	4-27-07	IG

ITEM	QTY	PART NO.	DESCRIPTION
6	A/R	00946	SEALANT, TAPE, 1/2" TEFLON
5	1	14297	NIPPLE, 1/8 x 1-1/2, BRASS
4	1	14556	SPRAY, NOZZLE, MALE 1/8" NPT
3	1	104838	COUPLING, 1/8" NPT - BRASS
2	1	105787	FITTING, HOSE BARB, 90°, 1/4 H X 1/8 NPT(M)
1	1	06230	FITTING, COMPARTMENT DRAIN

**CLEVELAND RANGE, LLC**  
 1333 East 179th St., Cleveland, Ohio 44110-2574

THIS DESIGN DESCRIBES A PROPRIETARY ITEM AND IS THE PROPERTY OF CLEVELAND RANGE.  
 THIS DRAWING IS NOT TO BE COPIED OR USED WITHOUT THE APPROVAL OF CLEVELAND RANGE.

TOLERANCES (UNLESS OTHERWISE NOTED)	DO NOT SCALE PRINTED DRAWING	DRAWN BY <b>LPH</b>	DATE <b>6/14/2006</b>
DECIMAL <b>± 0.030</b>	TITLE <b>CONDENSER SPRAY ASSY, GAS CHEF 3 &amp; 6</b>		
ANGULAR <b>± 1°</b>	SIZE <b>B</b>	DRAWING NO. <b>1119141</b>	SHEET 1 OF 1 REV <b>A</b>

LET.	DESCRIPTION	DATE	BY
A	PRODUCTION RELEASE PER EO#C-6729	10-5-04	IG
B	ADDED ITEMS 17-19 PER EO# C-7017	03-15-06	LPH
C	PICTORIAL UPDATE OF ITEM 1, RELOCATED ITEM 11 PER	03-26-07	LPH
-	PER EO# 07-096	-	-

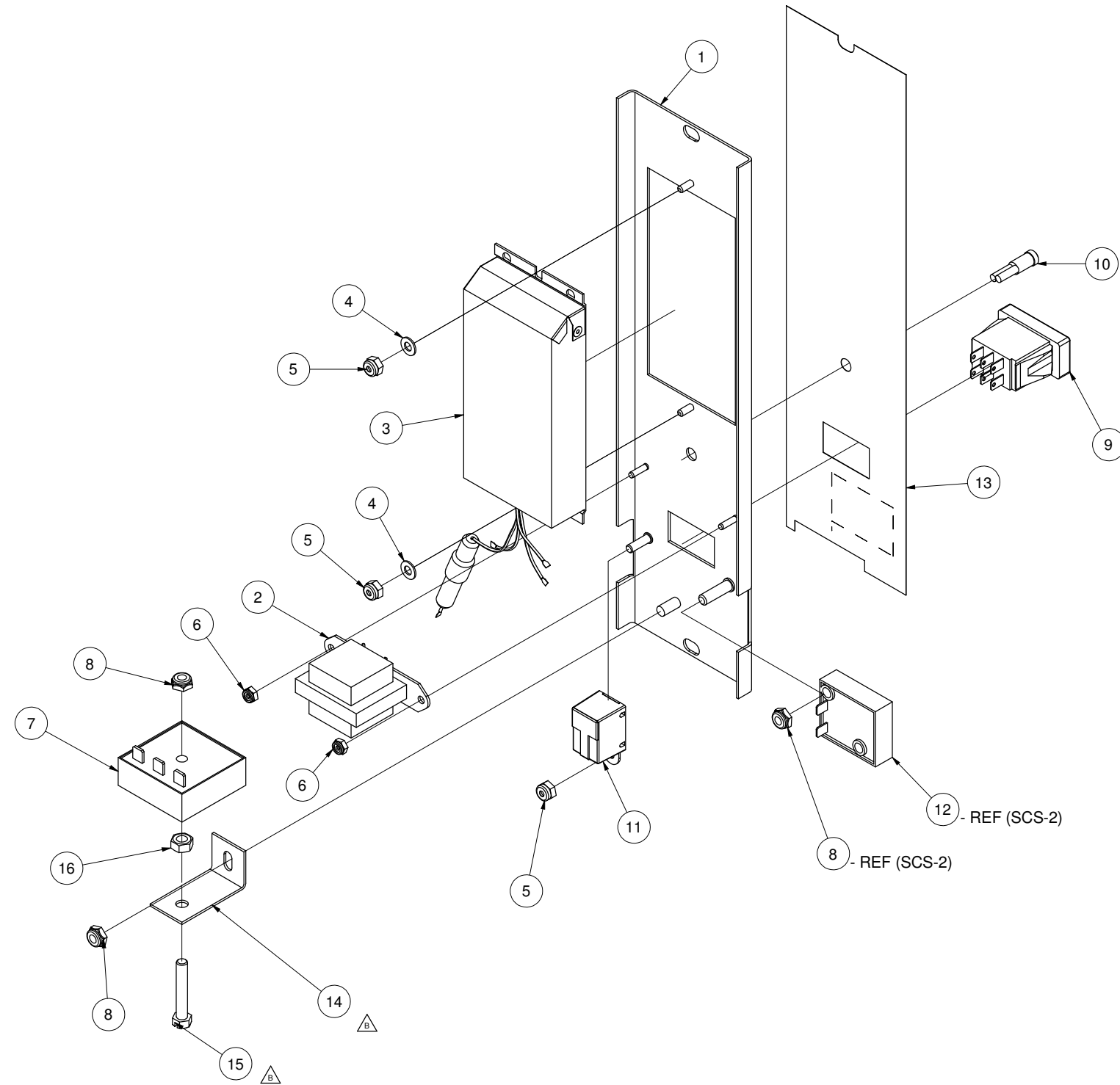

NOT SHOWN

19	1	20351	TERMINAL, SLIP-ON, FULL INSUL, .032X .250 TAB
18	1	300346	HARNESS, WIRE, ELEC CONTROL PANEL
17	1	109153	LABEL, SLIP-IN MODEL NO./SERIAL NO.
16	1	14617	NUT, HEX 1/4-20 STEEL OXIDE FINISH
15	1	19175	SCREW, HEX HD, NON-SLTD
14	1	105955	BRACKET, DUAL TIMER MOUNTING
13	1	1106681	LABEL, NCC TIMER, STEAMCHEF
12	-	108880	SWITCH, DOOR STEAM CUTOFF
11	1	41350	BUZZER, ASSY, CONTINUOUS DUTY, 120VAC, 50-60HZ
10	1	12159	LIGHT, INDICATOR, NEON, RED, 7" MIN LEAD LENGTH
9	1	104224	SWITCH, ROCKER DPDT, MATTE
8	2	101873	NUT, HEX 1/4-20 THIN LOCK, ZINC PLTD. STEEL
7	1	300150	TIMER, SOLID STATE, 60 MINUTE FIXED DELAY
6	2	104223	NUT, HEX 6-32 ELASTIC LOCK
5	3	14692	NUT, HEX, 10-24, ELASTIC LOCK, ZINC PLTD, FASTENER
4	2	101655	WASHER, FLAT, #10, SST
3	1	104389	TIMER ASSEMBLY NCC
2	1	104390	TRANSFORMER ASSEMBLY
1	1	1106641	PANEL, CONTROL, WELDMENT, ETC TIMER, STEAMCHEF, HL

ITEM	QTY	PART NO.	DESCRIPTION
<b>CLEVELAND RANGE, LLC</b>			
1333 East 179th St., Cleveland, Ohio 44110-2574			
<small>THIS DESIGN DESCRIBES A PROPRIETARY ITEM AND IS THE PROPERTY OF CLEVELAND RANGE. THIS DRAWING IS NOT TO BE COPIED OR USED WITHOUT THE APPROVAL OF CLEVELAND RANGE.</small>			
TOLERANCES (UNLESS OTHERWISE NOTED)	DO NOT SCALE PRINTED DRAWING	DRAWN BY <b>IGenzel</b>	DATE <b>10/5/2004</b>
DECIMAL ± 0.030	TITLE <b>PANEL, CTRL. ASSY, ETC, HL, W/60 MIN MANUAL TIMER, CHEF</b>		
ANGULAR ± 1°	SIZE <b>C</b>	DRAWING NO. <b>300348</b>	SHEET 1 OF 1 REV <b>C</b>

LET.	DESCRIPTION	DATE	BY
A	PRODUCTION RELEASE PER EO#C-6729	10-6-04	IG
B	PICTORIAL UPDATE , SWITCH ROTATED PER EO# C-7017	03-14-06	LPH
C	PICTORIAL UPDATE ITEM 1 PER ECR# 07-096	03-26-07	LPH

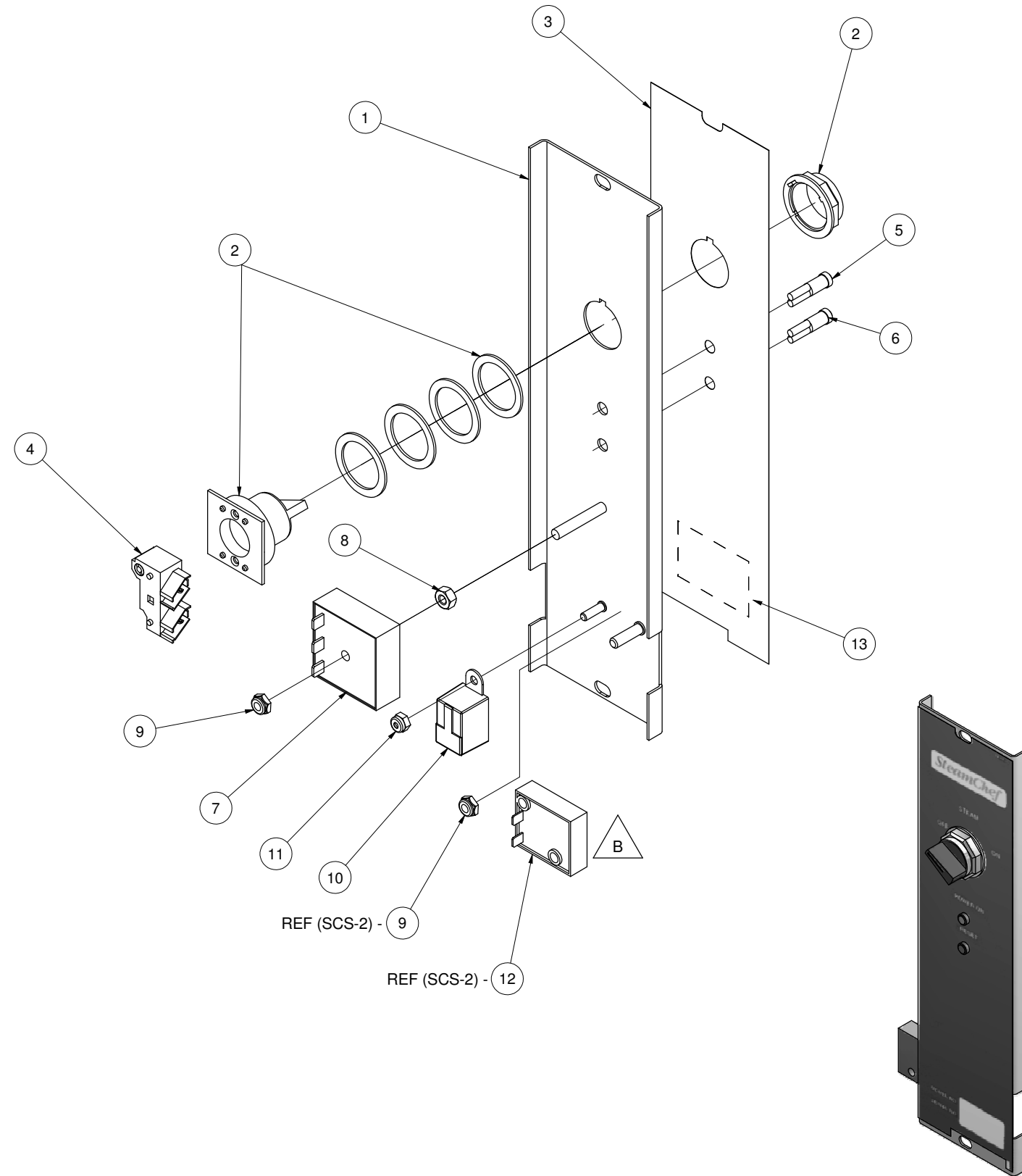

NOT SHOWN  
NOT SHOWN

REF

15	4	20351	TERMINAL SLIPON FULL-INSUL
14	1	300345	HARNESS, WIRE CTRL PANEL, ON-OFF
13	1	109153	LABEL, SLIP-IN, MODEL NO/SERIAL NO.
12	-	108880	SWITCH, DOOR STEAM CUTOFF
11	1	14692	NUT, HEX, 10-24, ELASTIC LOCK, ZINC PLTD, FASTENER
10	1	41350	BUZZER, ASSY, CONTINUOUS DUTY, 120VAC, 50-60HZ
9	1	101873	NUT, HEX 1/4-20 THIN LOCK, ZINC PLTD, STEEL
8	1	14618	NUT, HEX, 1/4-20, STAINLESS STEEL
7	1	300150	TIMER, SOLID STATE, 60 MINUTE FIXED DELAY
6	1	12159	LIGHT, INDICATOR, NEON, RED, 7" MIN LEAD LENGTH
5	1	109494	LIGHT, GREEN INDICATOR, NEON, 120V
4	1	102533	BLOCK, CONTACT
3	1	110669	LABEL, CTRL, ON/OFF, STEAMCHEF
2	1	102534	SWITCH, SELECTOR
1	1	110666	PANEL, CONTROL, WELDMENT, ON/OFF, STEAMCHEF, HL
ITEM	QTY	PART NO.	DESCRIPTION

CLEVELAND RANGE, LLC

1333 East 179th St., Cleveland, Ohio 44110-2574

THIS DESIGN DESCRIBES A PROPRIETARY ITEM AND IS THE PROPERTY OF CLEVELAND RANGE. THIS DRAWING IS NOT TO BE COPIED OR USED WITHOUT THE APPROVAL OF CLEVELAND RANGE.

TOLERANCES (UNLESS OTHERWISE NOTED)	DO NOT SCALE PRINTED DRAWING	DRAWN BY IGenzel	DATE 10/6/2004
DECIMAL ± 0.030	TITLE PANEL, CTRL, ASSY, ON-OFF, HL, CHEF		
ANGULAR ± 1°	SIZE C	DRAWING NO. 300347	SHEET 1 OF 1 REV C

**NOTE:**

1. APPLY ITEM 11 TO ITEMS 3, 5 & 10 IF REQUIRED.

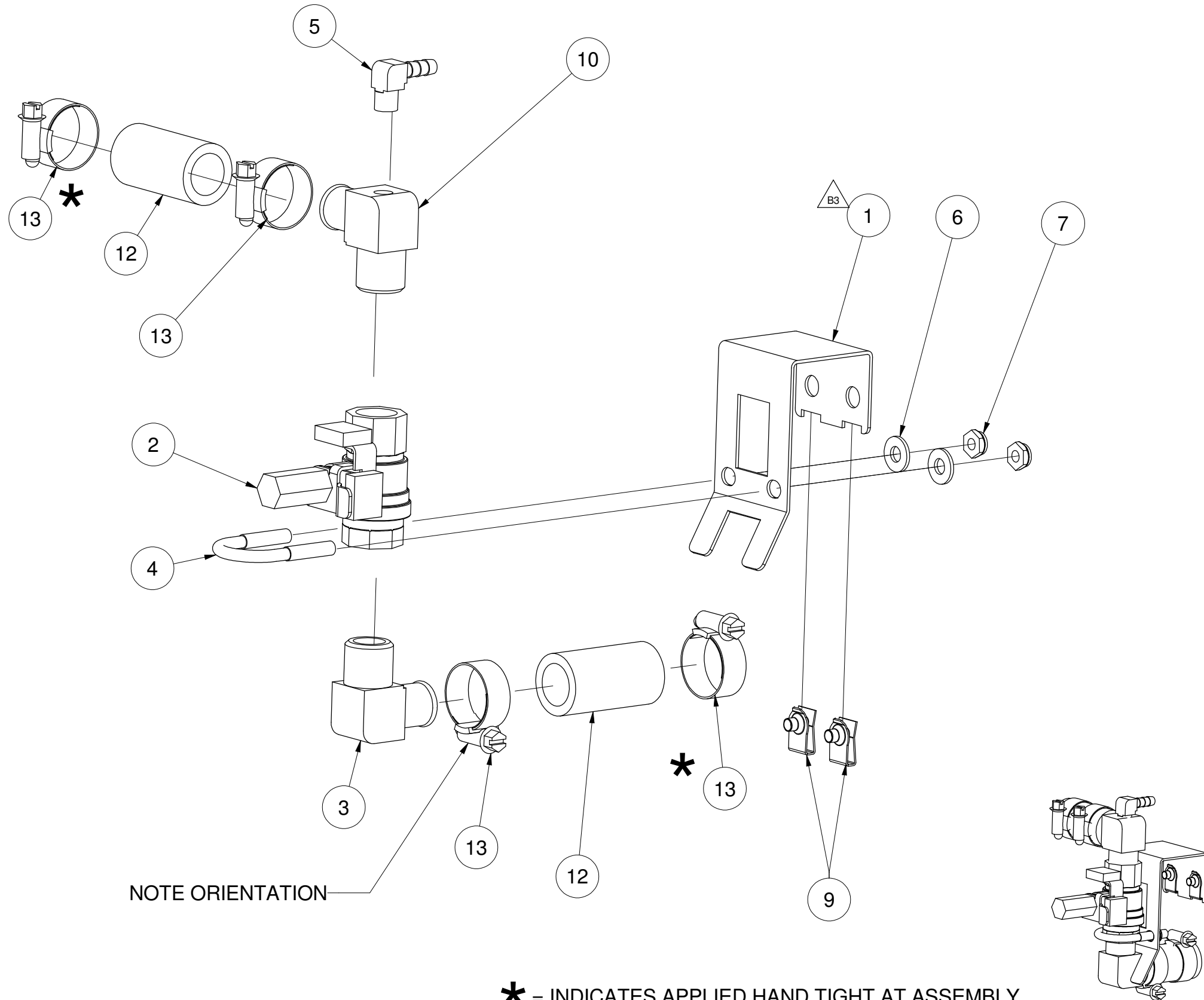

\* = INDICATES APPLIED HAND TIGHT AT ASSEMBLY.

LET.	DESCRIPTION	DATE	BY
A	PRODUCTION RELEASE "PER ECR 07-172"	05-03-07	LPH
B	ITEM 6 WAS P/N 23105, 2) ITEM 7 WAS P/N 14618, 3) PICT.	05-09-07	LPH
-	UPDATE ITEM 1, 4) ADD ITEMS 12 & 13 "PER ECR-07-209"	-	-
C	1) DELETED ITEM 8, 2) ITEM 9 WAS P/N 110581	06-08-07	LPH
-	"PER ECR-07-257"	-	-

B4	13	4	03207	HOSE, CLAMP, LINED, WORM DRIVE, MAX OD 1.125
B4	12	2	1060930200	HOSE, SILICONE, 3/4"ID X 2.000" LG.
	11	A/R	00934	SEALANT, PIPE DOPE
	10	1	1113541	FTG, BARB, 3/4H x 1/2 MPT x 1/8" FPT, 90 DEG, BRASS
C2	9	2	108734	NUT, "U" TYPE (EXTRUDED) #10-24 UNC-2B THREAD
C1	8			
B2	7	2	101873	NUT, HEX 1/4-20 THIN LOCK, ZINC PLTD. STEEL
B1	6	2	23116	WASHER, FLAT, .281 ID x .625 OD x .065 THK, SST
	5	1	105787	FITTING, HOSE BARB, 90°, 1/4 H X 1/8 NPT(M)
	4	1	110709	"U" BOLT, 1/2" PIPE, 1-4-20 THREAD, ZINC PLATED STL.
	3	1	111354	FTG, BARB, 3/4H x 1/2 MPT, 90 DEG, BRASS
	2	1	110613	BALL VALVE ASSEMBLY, DOUBLE SWITCH
	1	1	112406	BRACKET, VALVE MOUNT, GAS CHEF
ITEM	QTY	PART NO.	DESCRIPTION	

**CLEVELAND RANGE, LLC**

1333 East 179th St., Cleveland, Ohio 44110-2574

THIS DESIGN DESCRIBES A PROPRIETARY ITEM AND IS THE PROPERTY OF CLEVELAND RANGE. THIS DRAWING IS NOT TO BE COPIED OR USED WITHOUT THE APPROVAL OF CLEVELAND RANGE.

TOLERANCES (UNLESS OTHERWISE NOTED)	DO NOT SCALE PRINTED DRAWING	DRAWN BY <b>LPH</b>	DATE <b>5/3/2007</b>
DECIMAL <b>± 0.030</b>	TITLE <b>ASSEMBLY, PIPING, DRAIN/POWER, ON/OFF, HL</b>		
ANGULAR <b>± 1°</b>	SIZE <b>B</b>	DRAWING NO. <b>111919</b>	SHEET 1 OF 1 REV <b>C</b>

NOTE:  
 1.) INSTALL ITEM 7 AFTER ASSEMBLY P/N 111891 IS MOUNTED TO ELECTRICAL COMPONENT PANEL P/N 111802.

LET.	DESCRIPTION	DATE	BY
A	PRODUCTION RELEASE PER ECR-07-172	4-25-07	IG

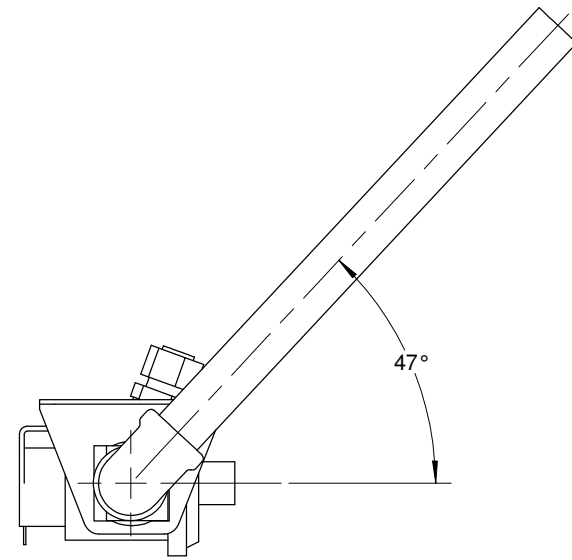

TOP VIEW

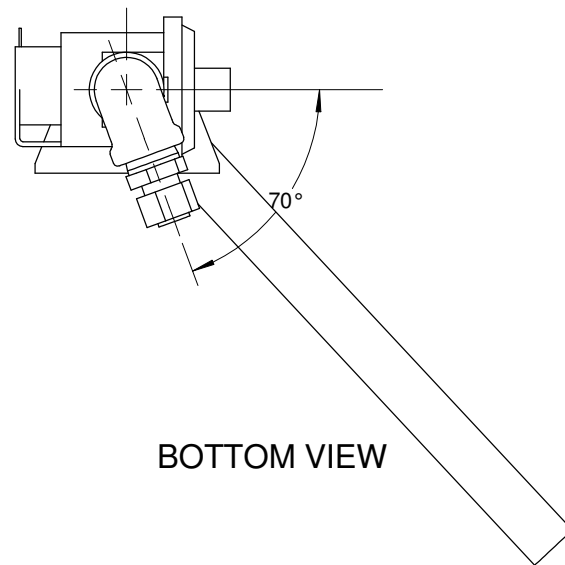

BOTTOM VIEW

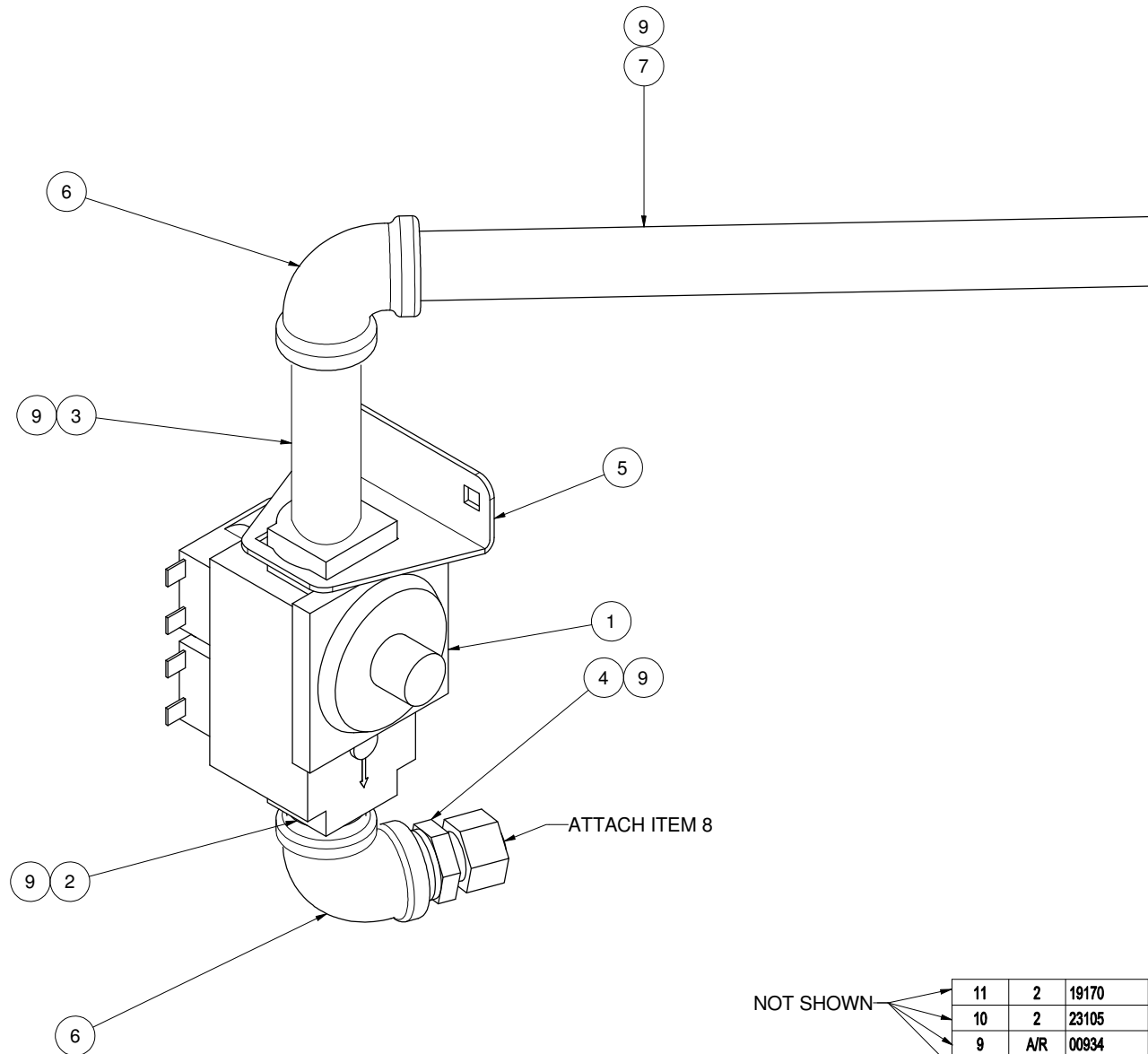

NOT SHOWN

11	2	19170	SCREW, 1/4-20 X 5/8, HEX HD. SST
10	2	23105	WASHER, LOCK, 1/4, SST
9	A/R	00934	THREAD SEALANT
8	1	111101	GAS LINE, FLEXIBLE, .5 X 13.000 LONG, SST
7	1	14441	NIPPLE, .50 NPT X 9.50 SCH. 40, BLK, TBE
6	2	05249	ELBOW, 90 DEG., 1/2" BLK
5	1	111799	BRACKET, GAS VALVE MOUNT
4	1	06204	FTG., COMP. 1/2T x 1/2MPT PARKER HANIFIN 68CA-8-8
3	1	14333	NIPPLE .50 NPT X 3.50 SCH 40, BLK, IRN, TBE
2	1	14323	NIPPLE, 1/2 x CLOSE, BLACK
1	1	1118141	VALVE, GAS, LP, COMBINATION, 1/2" NPT, 24VAC
ITEM	QTY	PART NO.	DESCRIPTION

CLEVELAND RANGE, LLC  
 1333 East 179th St., Cleveland, Ohio 44110-2574

THIS DESIGN DESCRIBES A PROPRIETARY ITEM AND IS THE PROPERTY OF CLEVELAND RANGE.  
 THIS DRAWING IS NOT TO BE COPIED OR USED WITHOUT THE APPROVAL OF CLEVELAND RANGE.

TOLERANCES (UNLESS OTHERWISE NOTED)	DO NOT SCALE PRINTED DRAWING	DRAWN BY LPH	DATE 3/1/2006
DECIMAL ± 0.030	TITLE GAS VALVE ASSY, LP, CHEF 3/6 HL		
ANGULAR ± 1°	SIZE C	DRAWING NO. 111891	SHEET 1 OF 1 REV A

NOTE:

1.) INSTALL ITEM 5 AFTER ASSEMBLY P/N 111890 IS MOUNTED TO ELECTRICAL COMPONENT PANEL P/N 111802.

LET.	DESCRIPTION	DATE	BY
A	PRODUCTION RELEASE PER ECR-07-172	4-25-07	IG

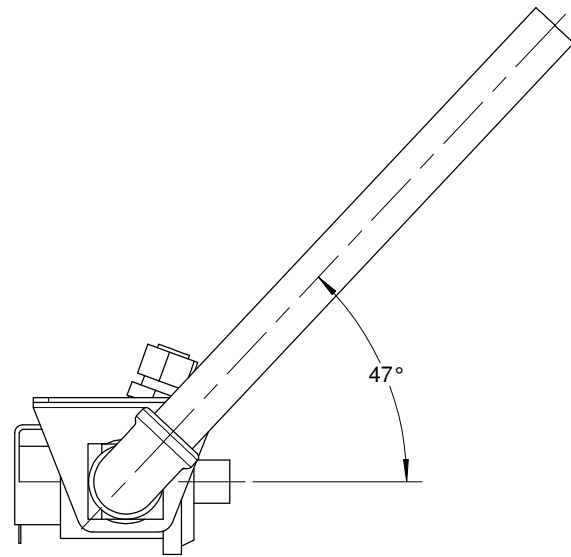

TOP VIEW

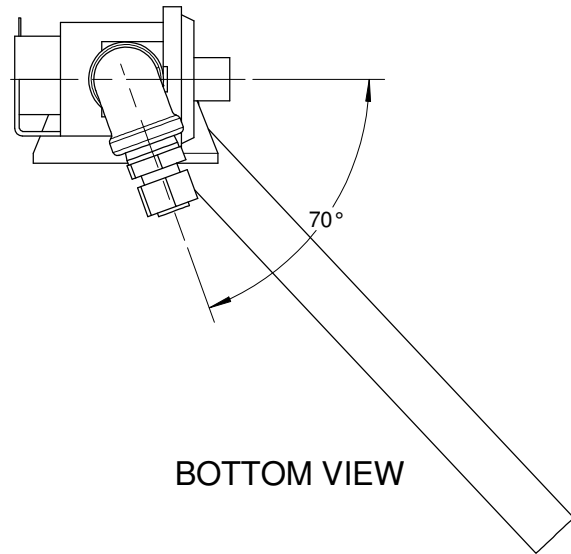

BOTTOM VIEW

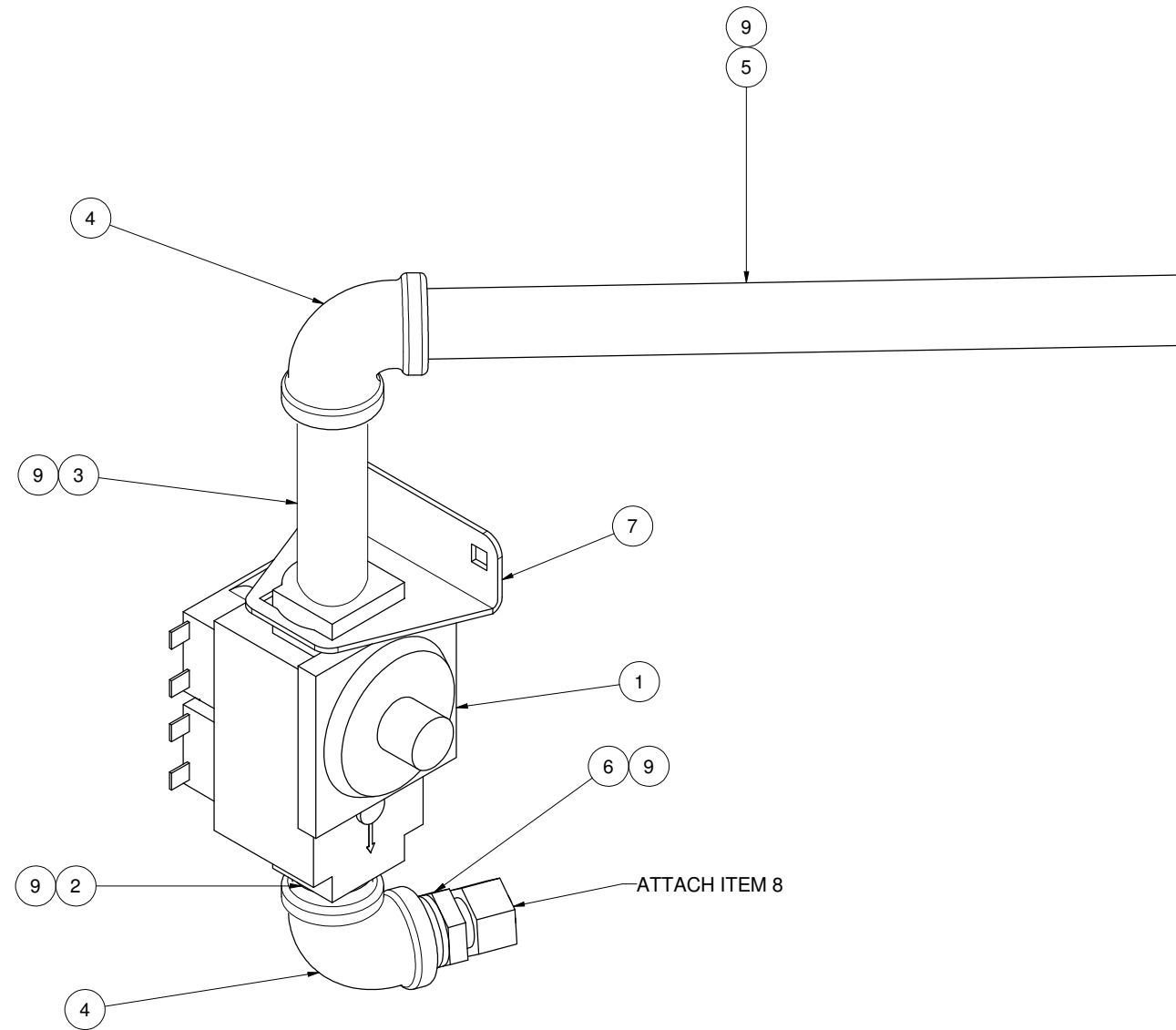

ITEM	QTY	PART NO.	DESCRIPTION
11	2	19170	SCREW, 1/4-20 X 5/8, HEX HD. SST
10	2	23105	WASHER, LOCK, 1/4, SST
9	A/R	00934	THREAD SEALANT
8	1	111101	GAS LINE, FLEXIBLE, .5 X 13.000 LONG, SST
7	1	111799	BRACKET, GAS VALVE MOUNT
6	1	06204	FTG., COMP. 1/2Tx1/2MPT PARKER HANIFIN 68CA-8-8
5	1	14441	NIPPLE, .50 NPT X 9.50 SCH. 40, BLK, TBE
4	2	05249	ELBOW, 90 DEG., 1/2" BLK
3	1	14333	NIPPLE .50 NPT X 3.50 SCH 40, BLK, IRN, TBE
2	1	14323	NIPPLE, 1/2 x CLOSE, BLACK
1	1	111814	VALVE, GAS, NATURAL, COMBINATION, 1/2" NPT, 24VAC

NOT SHOWN

<b>CLEVELAND RANGE, LLC</b> 1333 East 179th St., Cleveland, Ohio 44110-2574			
<small>THIS DESIGN DESCRIBES A PROPRIETARY ITEM AND IS THE PROPERTY OF CLEVELAND RANGE. THIS DRAWING IS NOT TO BE COPIED OR USED WITHOUT THE APPROVAL OF CLEVELAND RANGE.</small>			
TOLERANCES (UNLESS OTHERWISE NOTED)	DO NOT SCALE PRINTED DRAWING	DRAWN BY LPH	DATE 3/1/2006
TITLE			
<b>GAS VALVE ASSY, NAT, CHEF 3/6 HL</b>			
DECIMAL ± 0.030	SIZE C	DRAWING NO. 111890	SHEET 1 OF 1 REV A

ASSEMBLY NOTE:

1. GIVEN DIMENSIONS ARE REFERENCE ONLY UNLESS OTHERWISE NOTED.
2. THREAD ENGAGEMENT USED FOR THIS ASSEMBLY IS 0.500"

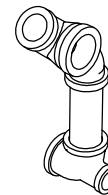
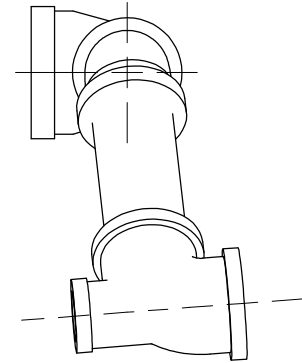
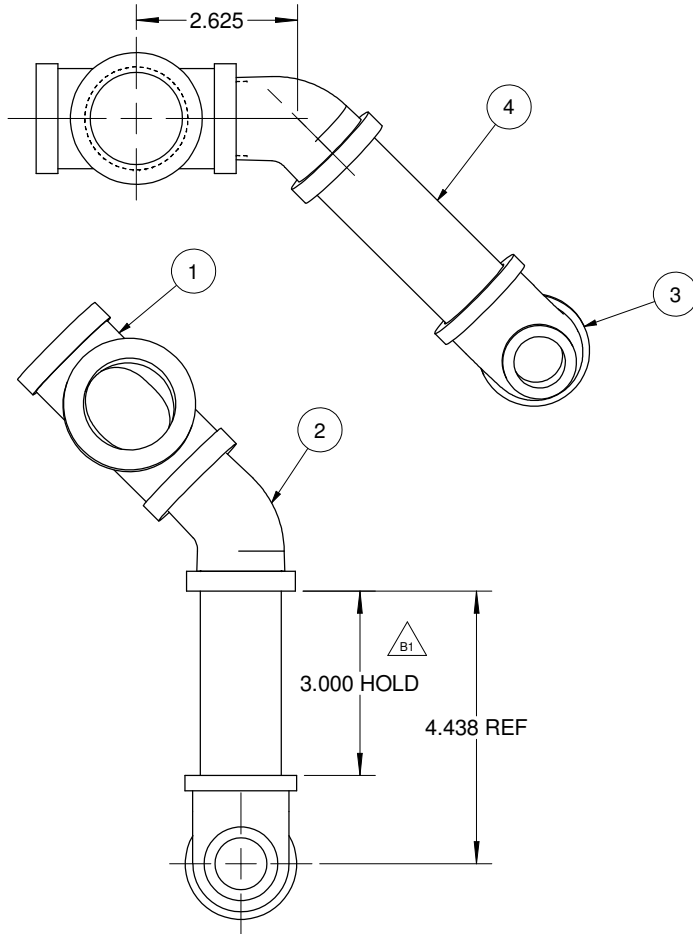

LET.	DESCRIPTION	DATE	BY
A	PRODUCTION RELEASE PER ECR-07-172	4-25-07	IG
B	1) DIM WAS 2.800 *PER ECR-07-257"	06-07-07	LPH

ITEM	QTY	PART NO.	DESCRIPTION
5	A/R	00934	SEALANT, PIPE DOPE
4	1	14494	NIPPLE, 1.00 NPT X 4.00 SCH. 40, BRASS, TBE
3	1	111153	TEE, 1" X 1/2" X 1", BRASS
2	1	111874	ELBOW, 1.00 NPT X 45 DEG. STREET, BRASS
1	1	111877	TEE, 1" X 1" X 1-1/4", BRASS

**CLEVELAND RANGE, LLC**  
1333 East 179th St., Cleveland, Ohio 44110-2574

THIS DESIGN DESCRIBES A PROPRIETARY ITEM AND IS THE PROPERTY OF CLEVELAND RANGE. THIS DRAWING IS NOT TO BE COPIED OR USED WITHOUT THE APPROVAL OF CLEVELAND RANGE.

TOLERANCES (UNLESS OTHERWISE NOTED)	DO NOT SCALE PRINTED DRAWING	DRAWN BY LPH	DATE 2/20/2006
DECIMAL ± 0.030	TITLE DRAIN ASSEMBLY, STEAMCHEF, HL		
ANGULAR ± 1°	SIZE B	DRAWING NO. 111886	SHEET 1 OF 1 REV B

NOTE:  
1. ITEM 21 IS PART OF THE LABEL PACKAGE.

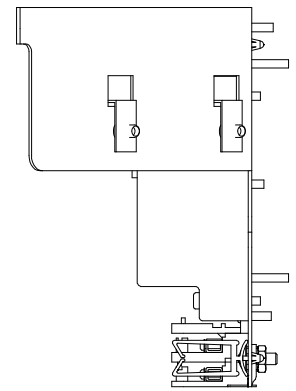
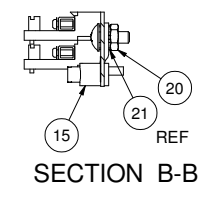
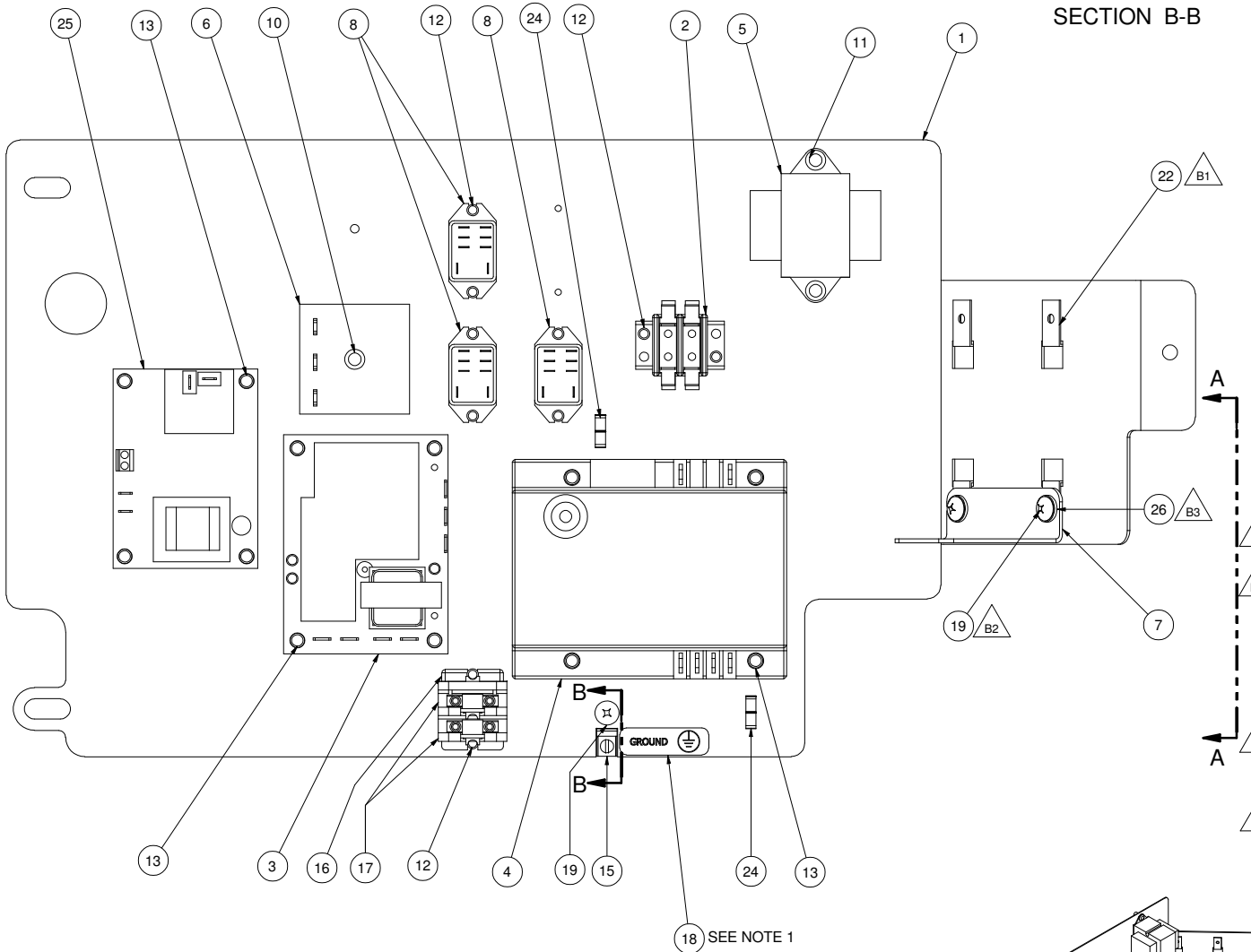

VIEW A-A

LET.	DESCRIPTION	DATE	BY
A	PRODUCTION RELEASE PER ECR-07-172	4-26-07	IG
B	PICTORIAL UPDATE, B1) ITEM 22 WAS 110581, WAS QTY 2	6-06-07	TJW
-	B2) REPLACE ITEMS 9, 108644 WITH ITEMS 19, B3) ADD ITEMS	-	-
-	26, B4) RMVD ITEMS 14 (14618) & 23 (23105); *PER ECR-07-257*	-	-

26	2	23105	WASHER, LOCK, 1/4" KATLINK STYLE, SST
25	1	300678	BOARD, SINGLE CHANNEL TEMPERATURE CONTROL
24	2	108612	CLIP, WIRE, VERTICAL, 0.740" X 0.420"
22	4	108734	NUT, "U" TYPE (EXTRUDED) #10-24 UNC-2B THREAD
21	2	23144	WASHER, LOCK, EXTERNAL TOOTH, #10 SST
20	1	14659	NUT, HEX, #10-24, SST
19	3	101231	SCREW, 10-24 X 0.500 SST, PHILLIPS TRUSS HEAD
18	1	14897	LABEL, GROUND
17	2	20301	TERMINAL SECTION, MARATHON
16	1	20302	TERMINAL, END SECTION
15	1	20304	LUG, GROUND
13	12	106128	SCREW, 6-32 X 1 TORX/PAN HD
12	10	106127	SCREW, 6-32 X 1/2, TORX/PAN HD
11	2	106123	SCREW, 10-32 X 1/2, TORX/PAN HD, THRD FORMING, ZN
10	1	106124	SCREW, TORX/SLOT #10-32 X 1-1/4 LG
8	3	105966	RELAY, DPDT-W/MTG TABS
7	1	111799	BRACKET, GAS VALVE MOUNT
6	1	20478	TIMER, SOLID STATE INTERV 3 MINUTE
5	1	20528	TRANSFORMER, 120-24V, 40VA, 50/60 HZ, 9" LEADS
4	1	03546	IGNITION, MODULE, CONTROL DIRECT SPARK, 4 SECOND
3	1	107241	BOARD, WATER LEVEL CONTROL
2	1	44168	TERMINAL, BLOCK ASM, 2 POLE
1	1	111800	COMPONENT PANEL, STEAMCHEF-GAS

ITEM	QTY	PART NO.	DESCRIPTION
<b>CLEVELAND RANGE, LLC</b> 1333 East 179th St., Cleveland, Ohio 44110-2574 <small>THIS DESIGN DESCRIBES A PROPRIETARY ITEM AND IS THE PROPERTY OF CLEVELAND RANGE. THIS DRAWING IS NOT TO BE COPIED OR USED WITHOUT THE APPROVAL OF CLEVELAND RANGE.</small>			
TOLERANCES (UNLESS OTHERWISE NOTED)		DO NOT SCALE PRINTED DRAWING	DRAWN BY LPH DATE 1/12/2006
DECIMAL ± 0.030		TITLE <b>COMPONENT PANEL ASSEMBLY, STEAMCHEF 3 &amp; 6 GAS</b>	
ANGULAR ± 1°		SIZE C DRAWING NO. 111802	SHEET 1 OF 1 REV B

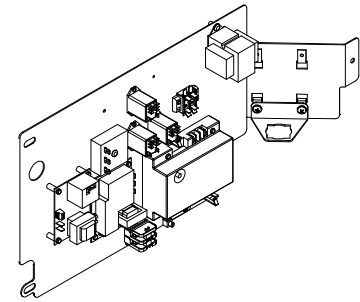

NOTE:  
ITEM 4 IS INSTALLED UNDERNEATH ITEM 7, (2) PLCS.

LET.	DESCRIPTION	DATE	BY
A	PRODUCTION RELEASE PER ECR-07-172	4-26-07	IG

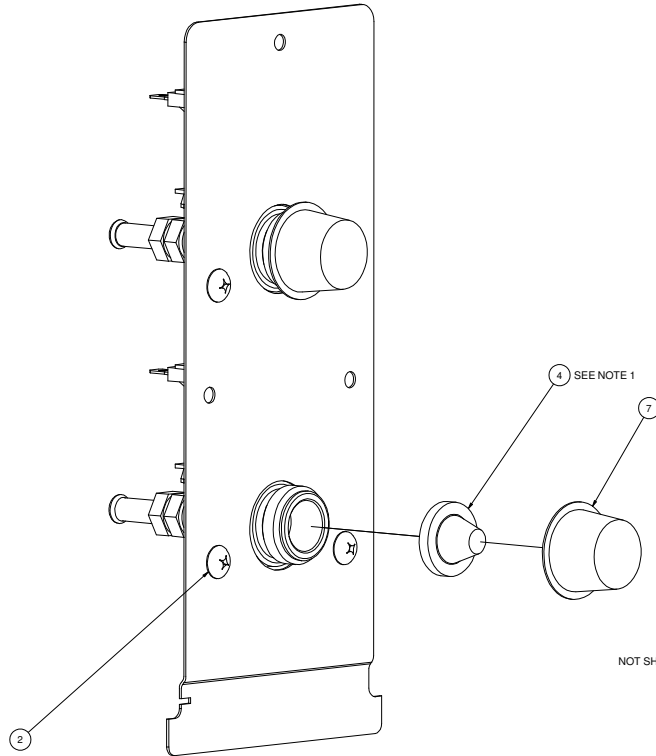
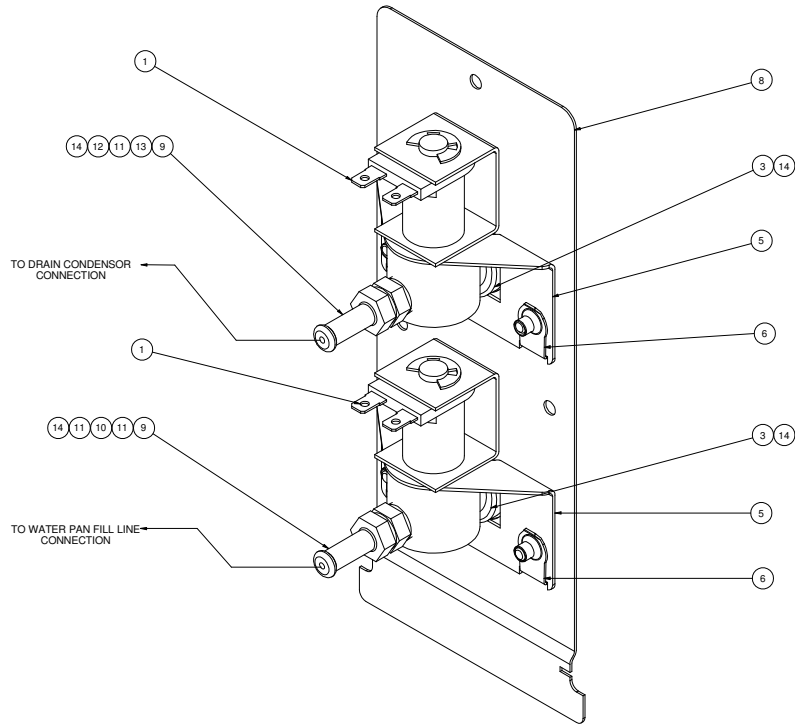

NOT SHOWN

14	AW	00591	SEALANT, PIPE DOPE
13	1	105501000	HOSE, 1/4"X1/2" SILICONE, REINFORCED
12	1	105259	CLAMP, NORM DRV, 1/4"AL, 5/16" WIDE
11	3	1073121	CLAMP, HOSE, 1/4" ID, METAL TENSION BAND
10	1	105801100	HOSE, 1/4" ID, 11.000' LG, SILICONE, REINFORCED
9	2	1008001	FLOW RESTRICTOR, JAG, FOR 1/4" ID HOSE
8	1	111944	COVER PLATE, WATER INLET, CHEF 3.8 GAS
7	2	111113	CAP, NON THREADED, PROTECTOR
6	4	106704	NUT, 1/4" TYPE (EXTRUDED) #14-18 UNC-2B THREAD
5	2	110364	BRACKET, VALVE MOUNT STEAM/HEAT
4	2	110367	STRAINER, FILTER WASHER, GARDEN HOSE INLET
3	2	110321	FITTING, 1/4-18 NPT X 3/4-11 NH
2	4	104231	SCREW, 10-24 X 0.500 SST, PHILLIPS TRUSS HEAD
1	2	22218	VALVE, SOLENOID, 1/4" NORM, 120 VOL.
ITEM	QTY	PART NO.	DESCRIPTION

CLEVELAND RANGE, LLC			
1833 East 79th St., Cleveland, Ohio 44116-2514			
DESIGNED BY: J. J. GIBSON / ENGINEERED BY: J. J. GIBSON / MANUFACTURED BY: J. J. GIBSON			
YOUNGBURG MANUFACTURING DIVISION	DATE OF FIRST PRINTED DRAWING	DESIGNED BY D. Peterson	DATE 10/27/2004
TOLERANCE ± 0.030	TITLE WATER VALVE ASSEMBLY, CHEF 3.8 GAS		
ANGULAR ± 1°	SIZE D	DRAWING NO. 111383	SHEET 1 OF 1 REV A

NOTE:  
FOR CORRECT ORIFICE PART NUMBER SEE WORK ORDER FOR SPECIFIC UNIT.

LET.	DESCRIPTION	DATE	BY
A	PRODUCTION RELEASE PER ECR-07-172	4-27-07	IG
B	CORRECTED PRODUCTSTREAM LINK AND ADDED PIPE DOPE	06-06-07	RS
-	IN PARTS LIST PER ECR-07-252	-	-

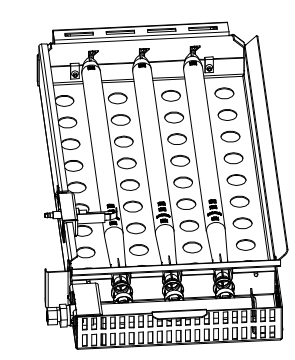
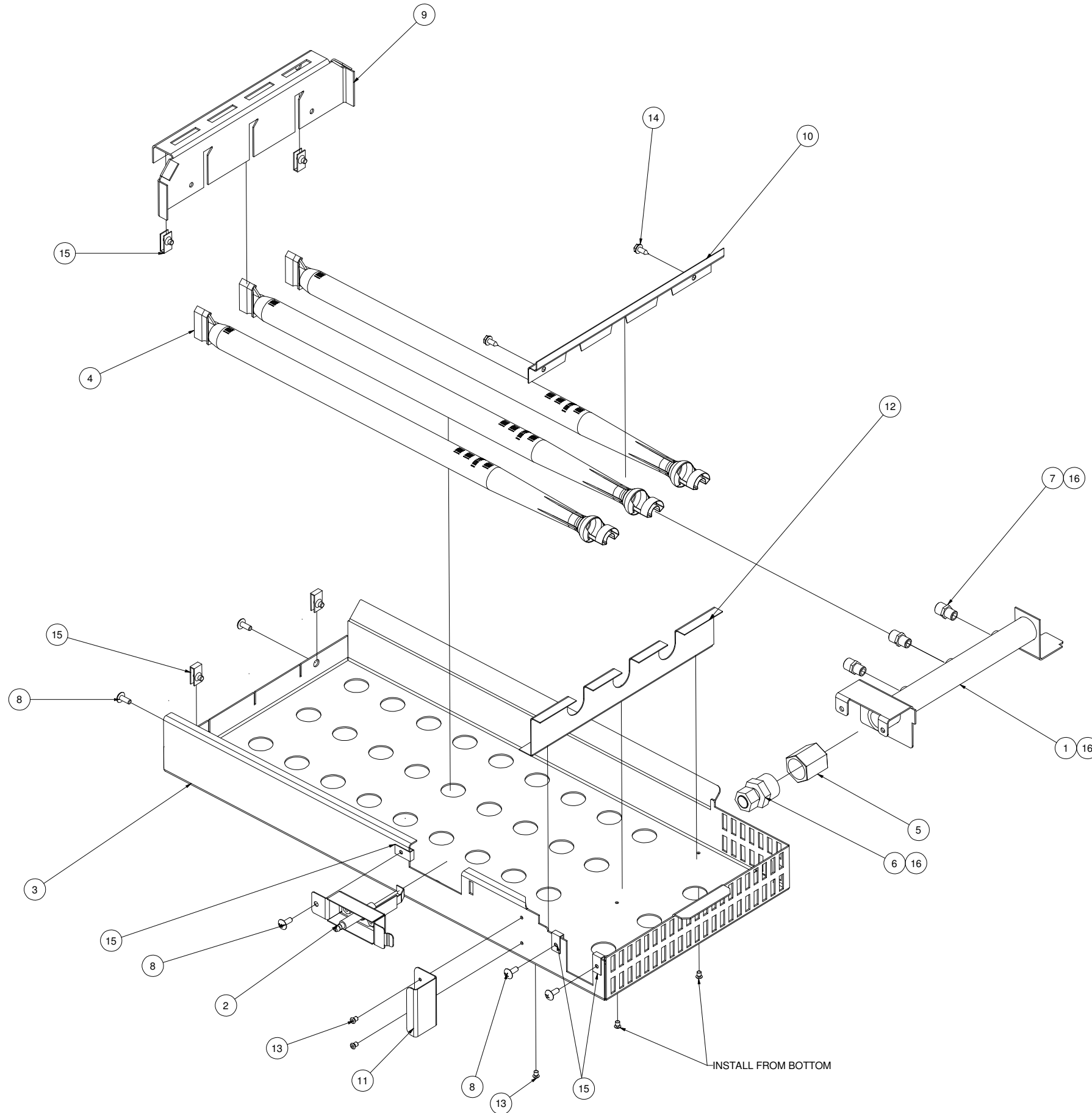

SEE NOTE

ITEM	QTY	PART NO.	DESCRIPTION
16	AR	00834	SEALANT, PIPE DOPE
15	7	108734	NUT, "U" TYPE (EXTRUDED) #10-24 UNC-2B THREAD
14	2	19148	SCREW, HEX WASHER HD, #10 x 1/2, TYPE AB, ZINC PLTD
13	5	18357	RIVET, FLUSH BREAK, 0.125 DIA, 0.128X0.187 GRIP, SST
12	1	111813	BAFFLE, AIR, BURNER SURROUND, H.L.
11	1	111811	BAFFLE, AIR, BURNER BOX RIGHT SIDE
10	1	111772	LOCK BAR, BURNER TUBE, CHEF, GAS, H.L.
9	1	111506	END CAP, BURNER TRAY
8	5	101231	SCREW, 10-24 X 0.500 SST, PHILLIPS TRUSS HEAD
7	3	111820	ORIFICE, BLANK, BECKETT BURNER
6	1	06206	COMPRESSION FTG
5	1	03612	COUPLING, FULL, 3/4", BR.
4	3	111355	BURNER, BECKETT, TUBE, 1", GAS BASE AND STEAMCHEF
3	1	111333	BURNER TRAY, CHEF 3.6 GAS, H.L.
2	1	111896	IGNITOR ASSY, GAS CHEF
1	1	111373	GAS MANIFOLD WELDMENT, H.L.

CLEVELAND RANGE, LLC				
1333 East 179th St., Cleveland, Ohio 44110-2574				
THE DESIGN DESCRIBED IS A PROPRIETARY ITEM AND IS THE PROPERTY OF CLEVELAND RANGE. THIS DRAWING IS NOT TO BE COPIED OR USED WITHOUT THE APPROVAL OF CLEVELAND RANGE.				
TOLERANCES (UNLESS OTHERWISE NOTED)	DO NOT SCALE PRINTED DRAWING	DRAWN BY	DATE	
DECIMAL ± 0.030		IG	4/27/2007	
ANGULAR ± 1°	SIZE D	DRAWING NO. 111329	SHEET 1 OF 2	REV B

# NAT

USED ON PRODUCT LINE
22CGT6 - C255, 0 - 1,999FT
22CGT6 - C256, 2,000 - 4,999FT
22CGT6 - C257, 5,000 - 5,999FT
22CGT6 - C258, 6,000 - 7,999FT
22CGT6 - C259, 8,000 - 9,999FT
22CGT6 - C260, 9,000 - 10,999FT

# 22CGT6

P/N:	DESCRIPTION	HOLE SIZE
111844	ORIFICE, #44 DMS , BECKETT	#44 (0.086±0.001 REF)
111845	ORIFICE, #45 DMS , BECKETT	#45 (0.082±0.001 REF)
111846	ORIFICE, #46 DMS , BECKETT	#46 (0.081±0.001 REF)
111847	ORIFICE, #47 DMS , BECKETT	#47 (0.079±0.001 REF)
111848	ORIFICE, #48 DMS , BECKETT	#48 (0.076±0.001 REF)
111849	ORIFICE, #49 DMS , BECKETT	#49 (0.073±0.001 REF)
111855	ORIFICE, #55 DMS , BECKETT	#55 (0.052±0.001 REF)
111856	ORIFICE, #56 DMS , BECKETT	#56 (0.047±0.001 REF)
111857	ORIFICE, #57 DMS , BECKETT	#57 (0.043±0.001 REF)

# LP

CHECK WITH PIN GAUGES
22CGT6 - C271, 0 - 4,999FT
22CGT6 - C272, 5,000 - 9,999FT
22CGT6 - C273, 10,000 - 10,999FT

# NAT

USED ON PRODUCT LINE
22CGT3 - C249, 0 - 1,999FT
22CGT3 - C250, 2,000 - 4,999FT
22CGT3 - C251, 5,000 - 7,999FT
22CGT3 - C252, 8,000 - 10,999FT

# 22CGT3

P/N:	DESCRIPTION	HOLE SIZE
111849	ORIFICE, #49 DMS , BECKETT	#49 (0.073±0.001 REF)
111850	ORIFICE, #50 DMS , BECKETT	#50 (0.070±0.001 REF)
111851	ORIFICE, #51 DMS , BECKETT	#51 (0.067±0.001 REF)
111852	ORIFICE, #52 DMS , BECKETT	#52 (0.064±0.001 REF)
1118561	ORIFICE, 1.15mm , BECKETT	1.15mm (0.045±0.001 REF)
111857	ORIFICE, #57 DMS , BECKETT	#57 (0.043±0.001 REF)
111858	ORIFICE, #58 DMS , BECKETT	#58 (0.042±0.001 REF)
111859	ORIFICE, #59 DMS , BECKETT	#59 (0.041±0.001 REF)
111860	ORIFICE, #60 DMS , BECKETT	#60 (0.040±0.001 REF)
111861	ORIFICE, #61 DMS , BECKETT	#61 (0.039±0.001 REF)

# LP

CHECK WITH PIN GAUGES
22CGT3 - C263, 0 - 2,999FT
22CGT3 - C264, 3,000 - 5,999FT
22CGT3 - C265, 6,000 - 6,999FT
22CGT3 - C266, 7,000 - 8,999FT
22CGT3 - C267, 9,000 - 9,999FT
22CGT3 - C268, 10,000 - 10,999FT



LET.	DESCRIPTION	DATE	BY
A	PRODUCTION RELEASE "PER ECR-07-172"	05-02-07	TJW

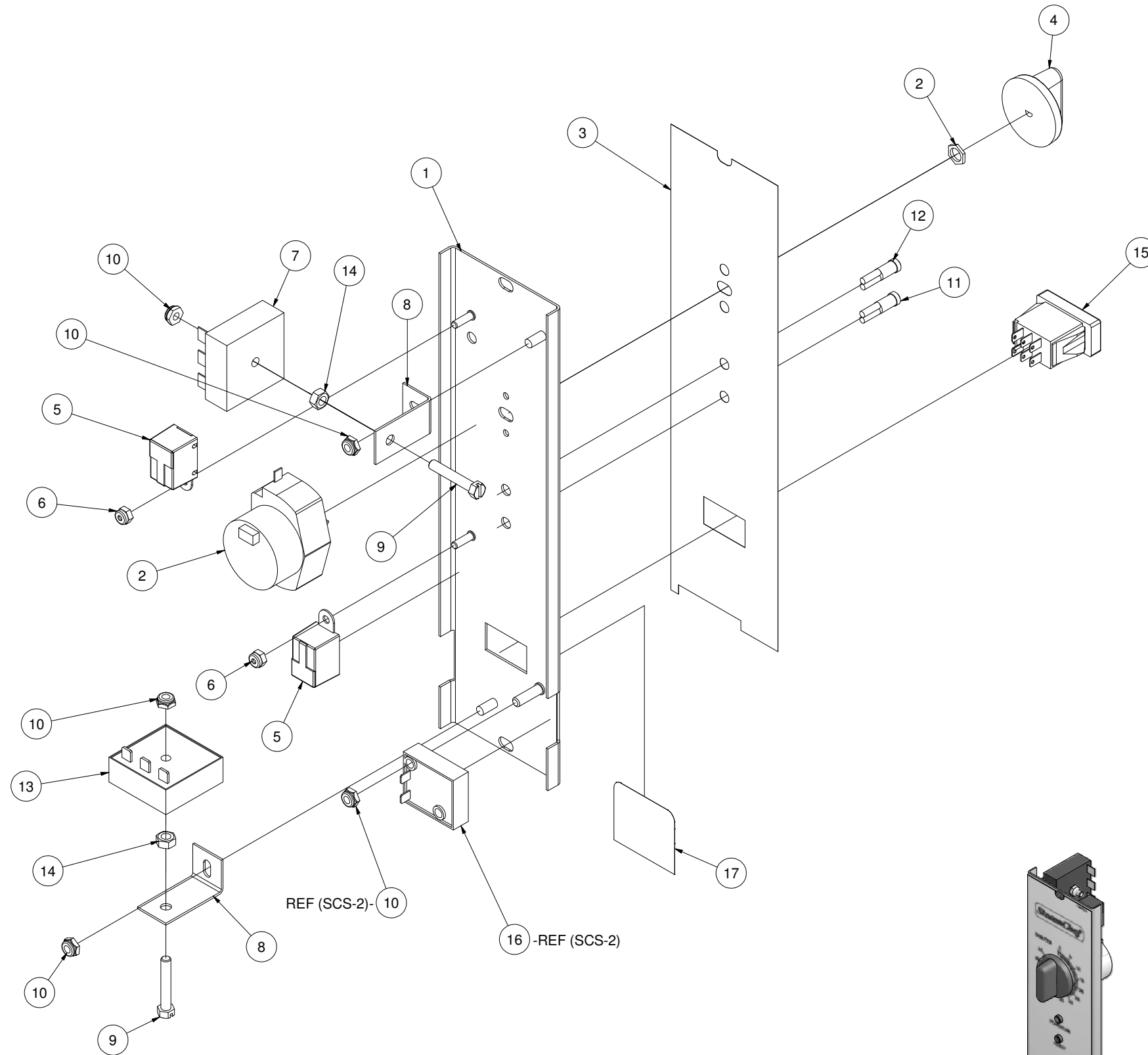

NOT SHOWN {  
REF

19	6	20351	TERMINAL, SIPHON FULL-INSUL.
18	1	300333	HARNES, MECH TIMER PANEL
17	1	109153	LABEL, SLIP IN, MODEL NUMBER / SERIAL NUMBER
16	1	108880	SWITCH, DOOR STEAM CUTOFF
15	1	104224	SWITCH, ROCKER DPDT, MATTE
14	2	14817	NUT, HEX 1/4-20 STEEL OXIDE FINISH
13	1	300150	TIMER, SOLID STATE, 60 MINUTE FIXED DELAY
12	1	109494	LIGHT, GREEN INDICATOR, NEON, 120V
11	1	12159	LIGHT, INDICATOR, NEON, RED, 7" MIN LEAD LENGTH
10	5	101873	NUT, HEX 1/4-20 THIN LOCK, ZINC PLTD. STEEL
9	2	19175	SCREW, HEX HD, NON-SLTD FULL THRD 1/4-20x1.50 ZNC PLTD
8	2	105955	BRACKET, DUAL TIMER MOUNTING
7	1	20477	TIMER, SOLID STATE, 3 SEC DELAY ON BREAK
6	2	14692	NUT, HEX, 10-24, ELASTIC LOCK, ZINC PLTD, FASTENER
5	2	41350	BUZZER, ASSY, CONTINUOUS DUTY, 120VAC, 50-60HZ
4	1	110661	KNOB, EAGLE TIMER
3	1	1106672	LABEL, CONTROL PANEL, MECH.
2	1	110198	TIMER, MOTOR DRIVEN, 60 MIN. 115V 60HZ
1	1	111451	PANEL, CONTROL, WELDM., MECH. TIMER, STEAMCHEF, HL
ITEM	QTY	PART NO.	DESCRIPTION

CLEVELAND RANGE, LLC  
1333 East 179th St., Cleveland, Ohio 44110-2574

THIS DESIGN DESCRIBES A PROPRIETARY ITEM AND IS THE PROPERTY OF CLEVELAND RANGE.  
THIS DRAWING IS NOT TO BE COPIED OR USED WITHOUT THE APPROVAL OF CLEVELAND RANGE.

TOLERANCES (UNLESS OTHERWISE NOTED)	DO NOT SCALE PRINTED DRAWING	DRAWN BY TJW	DATE 5/2/2007
DECIMAL ± 0.030	TITLE PANEL ASSY, MECH. TIMER, CHEF, GAS-HL		
ANGULAR ± 1°	SIZE C	DRAWING NO. 3003312	SHEET 1 OF 1 REV A

STEAMCHEF 3 / 6 MECH TIMER ( GAS )

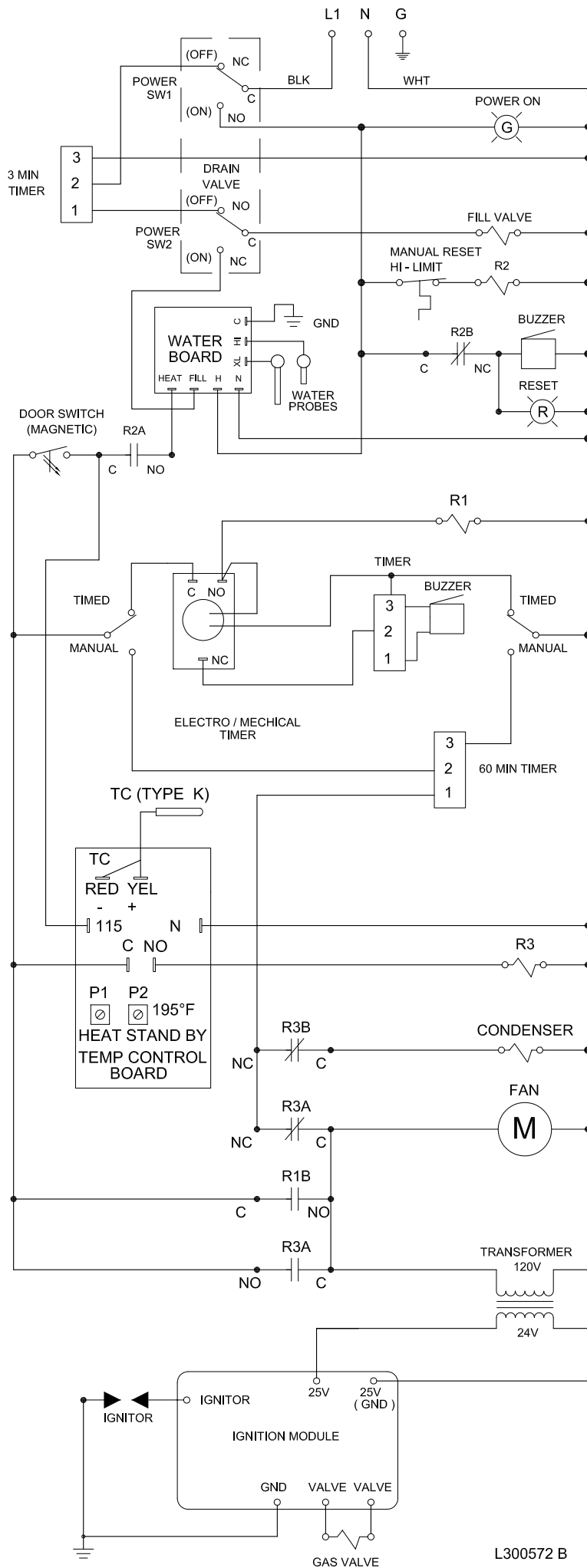

# STEAMCHEF 3 / 6 MECH TIMER ( GAS )

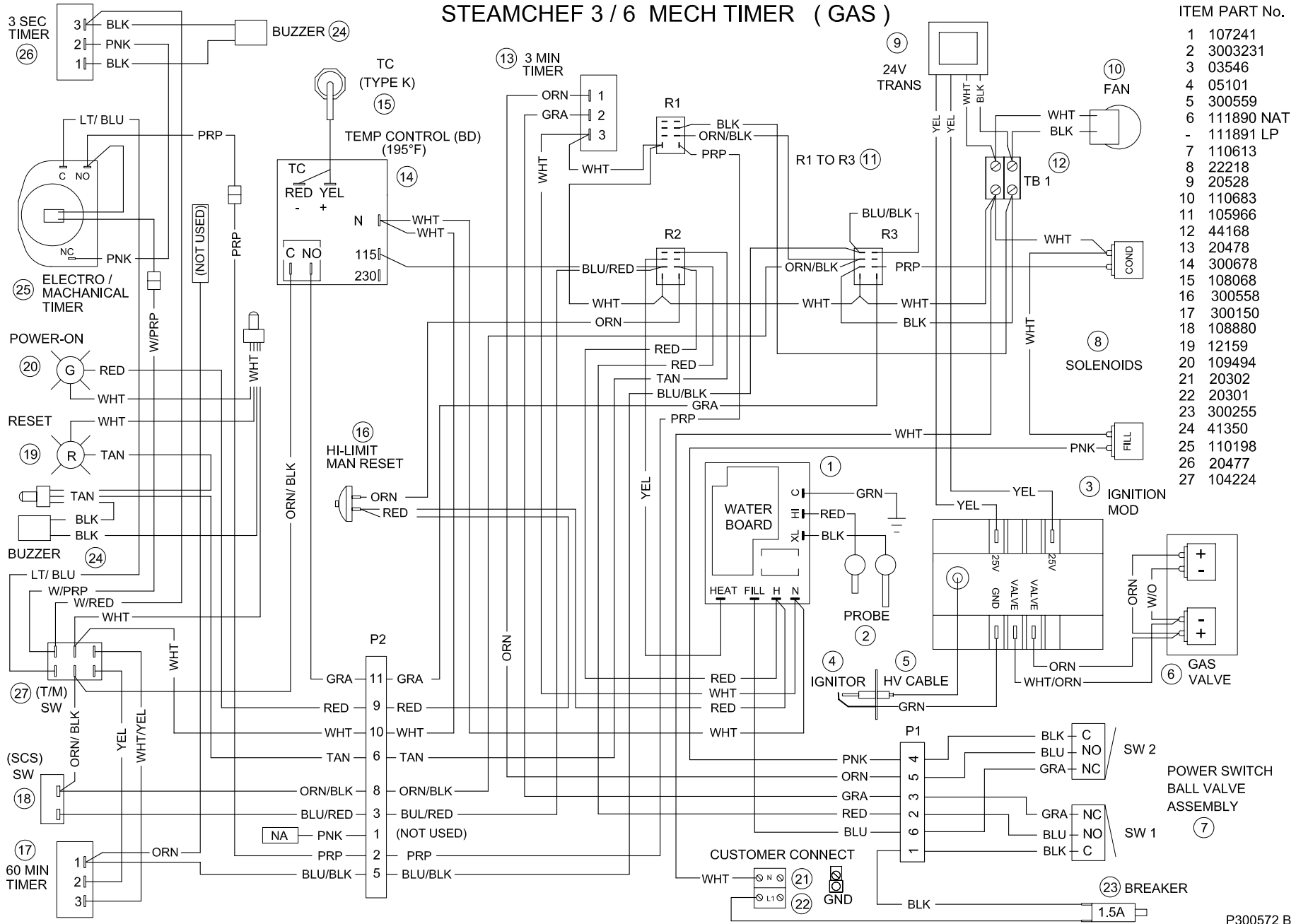

ITEM	PART No.
1	107241
2	3003231
3	03546
4	05101
5	300559
6	111890 NAT
-	111891 LP
7	110613
8	22218
9	20528
10	110683
11	105966
12	44168
13	20478
14	300678
15	108068
16	300558
17	300150
18	108880
19	12159
20	109494
21	20302
22	20301
23	300255
24	41350
25	110198
26	20477
27	104224

STEAMCHEF 3 / 6 ELECTRONIC TIMER ( GAS )

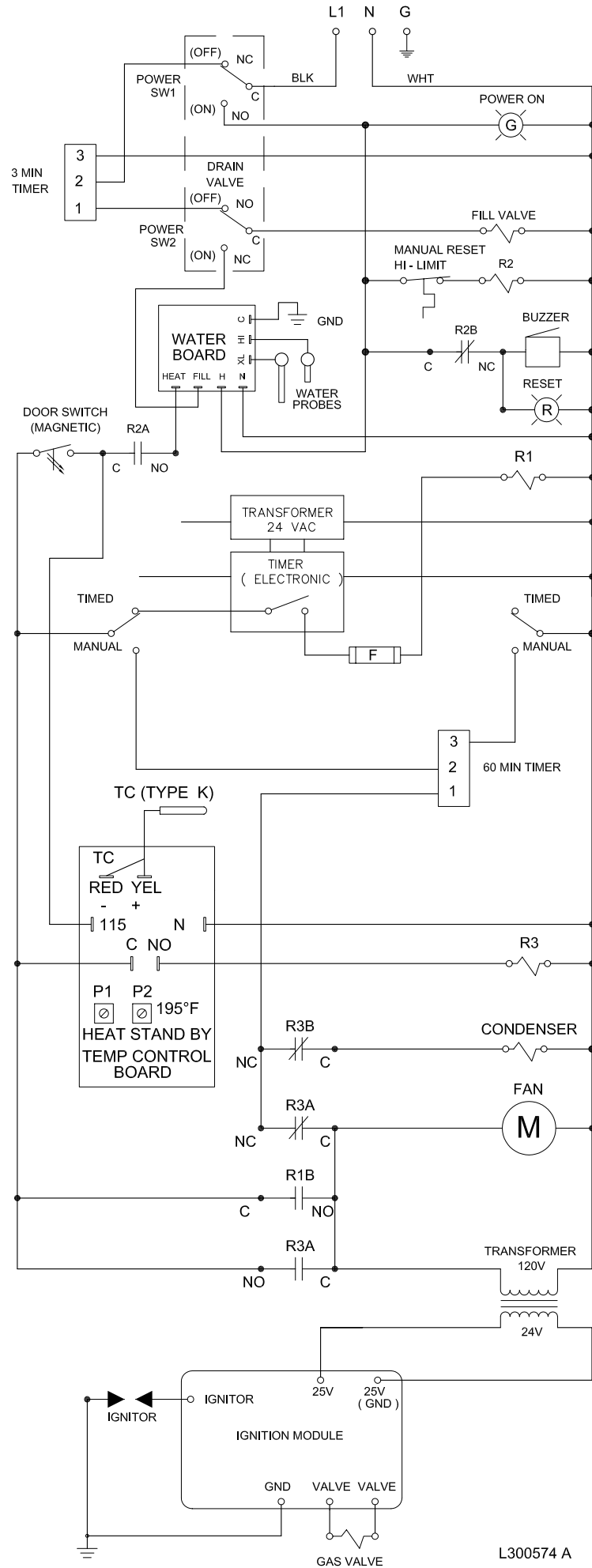

# STEAMCHEF 3 / 6 ELECTRONIC TIMER ( GAS )

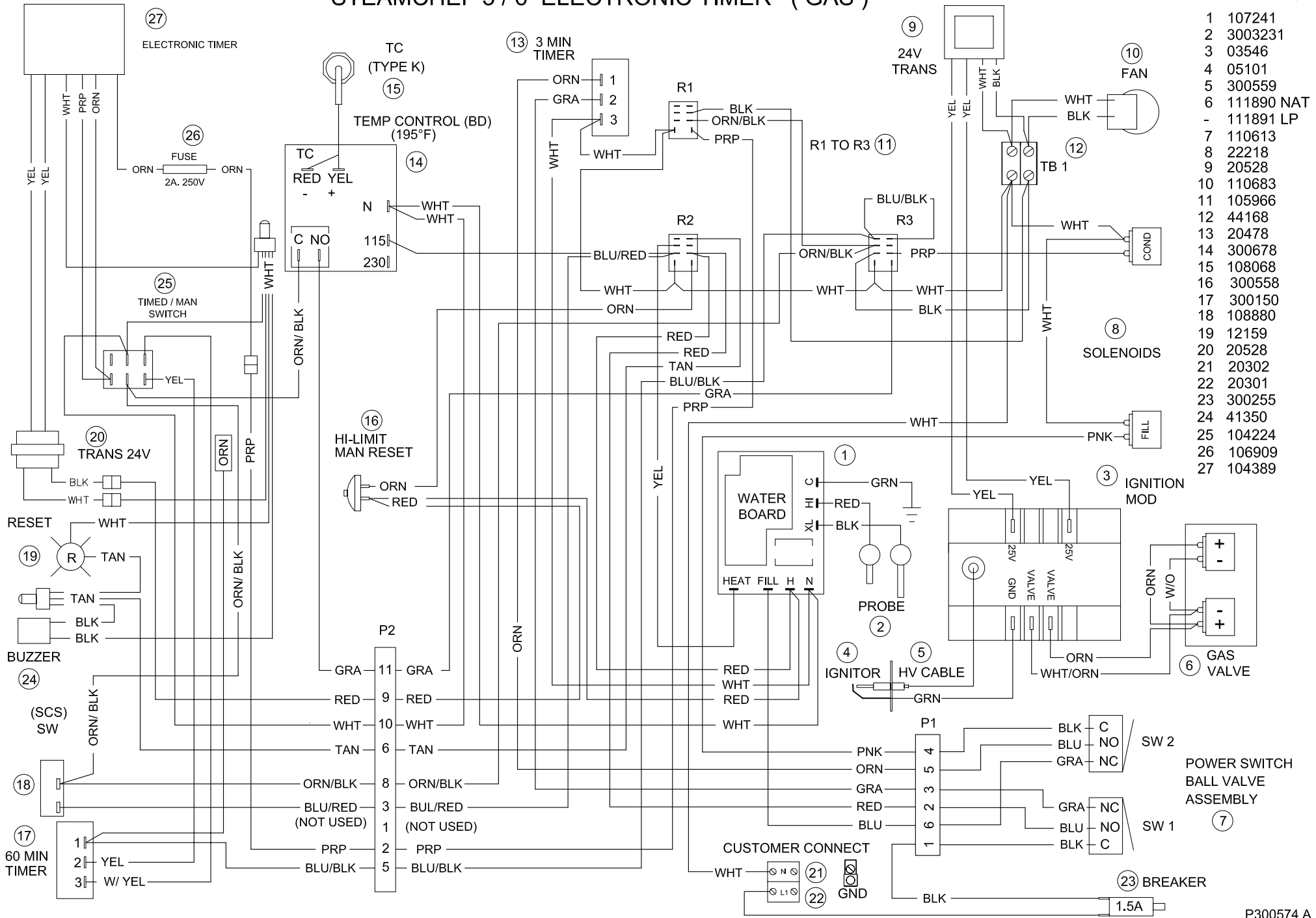

STEAMCHEF 3 / 6 ON/OFF CONTROL ( GAS )

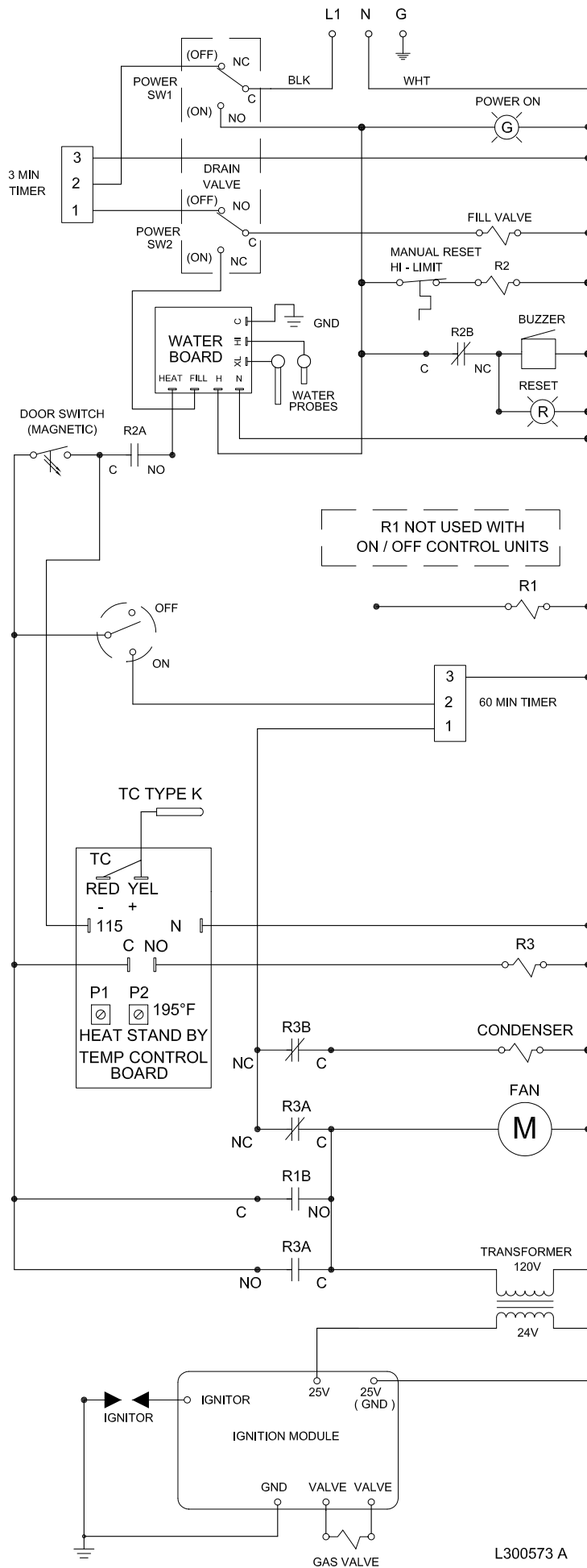

# STEAMCHEF 3 / 6 ON/OFF CONTROL ( GAS )

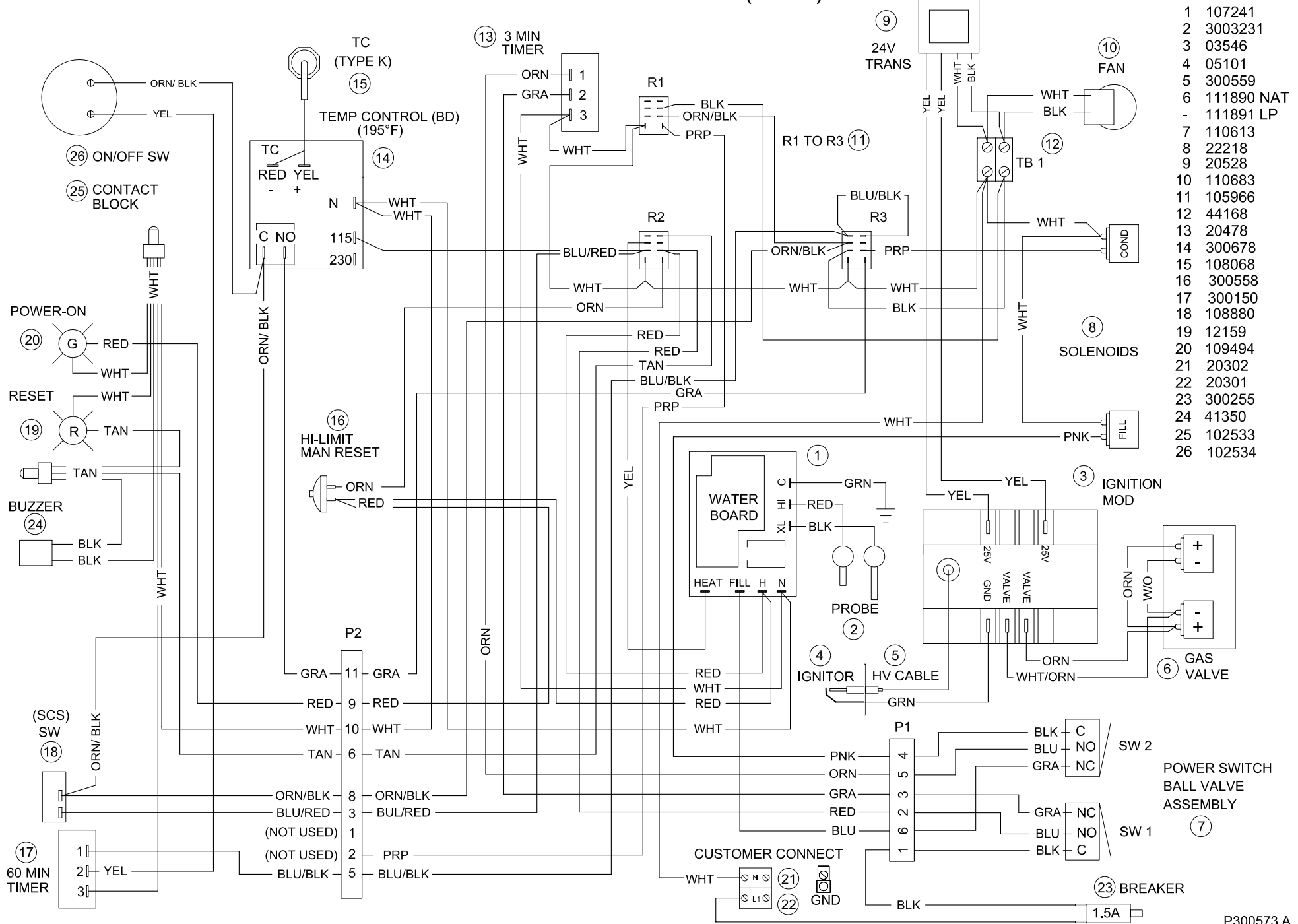

ITEM	PART No.
1	107241
2	3003231
3	03546
4	05101
5	300559
6	111890 NAT
-	111891 LP
7	110613
8	22218
9	20528
10	110683
11	105966
12	44168
13	20478
14	300678
15	108068
16	300558
17	300150
18	108880
19	12159
20	109494
21	20302
22	20301
23	300255
24	41350
25	102533
26	102534