



Visit [www.clevelandrange.com](http://www.clevelandrange.com) to locate a service or sales representative in your area.

# Cleveland

## SteamCraft® 10

# Direct Steam Convection Steamer with Easy Timer

## Operation, Installation & Maintenance Manual

This manual is updated as new information and models are released. Visit our website for the latest manual.

**MODEL:**

24CDP10

*For your future reference.*

Model # \_\_\_\_\_

Serial # \_\_\_\_\_



***Read the manual thoroughly.  
Improper installation, operation or  
maintenance can cause property  
damage, injury, or death.***

Part # KE004030-2 Rev A  
February 2024

# **STATEMENT OF RESPONSIBILITIES / DÉCLARATION DES RESPONSABILITÉS / DECLARACIÓN DE RESPONSABILIDADES**

This document is for use by experienced and trained Qualified Cleveland Range, LLC Authorized Service Representatives who are familiar with both the safety procedures, and equipment they service. Cleveland Range, LLC assumes no liability for any death, injury, equipment damage, or property damage resulting from use of, improper use of, or failure to use the information contained in this document. Cleveland Range, LLC has made every effort to provide accurate information in this document but cannot guarantee that this document does not contain unintentional errors and omissions.

The information in this document may be subject to technical and technological changes, revisions, or updates. Cleveland Range, LLC assumes no liability or responsibility regarding errata, changes, revisions, or updates.

Qualified Cleveland Range, LLC Authorized Service Representatives are obligated to follow industry standard safety procedures, including, but not limited to, OSHA regulations, and disconnect / lock out / tag out procedures for all utilities including steam, and disconnect / lock out / tag out procedures for gas, electric, and steam powered equipment and / or appliances.

All utilities (gas, electric, water and steam) should be turned OFF to the equipment and locked out of operation according to OSHA approved practices during any servicing of Cleveland Range equipment.

Qualified Cleveland Range, LLC Authorized Service Representatives are obligated to maintain up-to-date knowledge, skills, materials, and equipment.

Ce document est destiné à l'usage des Représentants de Service qualifiés et autorisés de Cleveland Range, LLC qui possèdent l'expérience et la formation ainsi que la bonne connaissance des mesures de sécurité et du matériel qu'ils entretiennent.

Cleveland Range, LLC décline toute responsabilité pour tout cas de décès, blessure, dommage matériel ou dommage aux biens résultant de l'utilisation, de la mauvaise utilisation ou du manquement d'utilisation des renseignements contenus dans ce document.

Cleveland Range, LLC s'est efforcé à fournir des renseignements précis dans ce document mais ne peut garantir que ce document soit exempt d'erreurs et d'omissions non intentionnelles.

Les renseignements contenus dans ce document peuvent être assujettis à des changements techniques et technologiques, des révisions ou des mises à jour.

Cleveland Range, LLC décline toute obligation ou responsabilité concernant les errata, modifications, révisions ou mises à jour.

Les Représentants de Service qualifiés et autorisés de Cleveland Range, LLC sont tenus de se conformer aux mesures de sécurité normalisées de l'industrie, y compris, mais sans s'y limiter, les réglementations de l'OSHA, les procédures de débranchement / verrouillage / étiquetage relatives à tous les services publics, dont l'approvisionnement en vapeur, et les procédures de débranchement / verrouillage / étiquetage relatives aux équipements et/ou appareils fonctionnant au gaz, à l'électricité et à la vapeur.

Au cours de tout entretien d'un appareil Cleveland Range, tous les services publics (gaz, électricité, eau et vapeur) doivent être FERMÉS au niveau de l'appareil et le dispositif de fonctionnement doit être verrouillé suivant les pratiques approuvées de l'OSHA.

Les Représentants de Service qualifiés et autorisés de Cleveland Range, LLC sont tenus d'actualiser en permanence leurs connaissances, compétences, matériel et équipement.

Este documento está destinado para el uso de los Representantes de Servicio calificados y autorizados de Cleveland Range, LLC quienes cuentan con la experiencia y la capacitación, así como el buen conocimiento de las medidas de seguridad y de los equipos que mantienen.

Cleveland Range, LLC, declina toda responsabilidad en caso de cualquier fallecimiento, lesiones, daños al equipo o daños a la propiedad resultantes de la utilización, del uso indebido o de la falta de utilización de la información provista en este documento.

Cleveland Range, LLC se ha esforzado en suministrar información precisa en este documento, pero no puede garantizar que este documento esté exento de errores y de omisiones no intencionales.

La información contenida en este documento podría estar sujeta a cambios técnicos o tecnológicos, revisiones o actualizaciones. Cleveland Range, LLC declina toda obligación o responsabilidad con respecto a erratas, modificaciones, revisiones o actualizaciones.

Los Representantes de Servicio calificados y autorizados de Cleveland Range, LLC tienen la obligación de seguir los procedimientos estándar de seguridad de la industria; los cuales incluyen pero no se limitan a los reglamentos de la OSHA (La Administración de la Seguridad y Salud Ocupacionales), los procedimientos de desconexión, cierre y etiquetado relativos a todos los servicios públicos incluyendo el suministro de vapor y los procedimientos de desconexión, cierre y etiquetado para los equipos y/o aparatos que funcionan a base de gas, electricidad o vapor.

Cuando se esté dando servicio o mantenimiento a un aparato de Cleveland Range, todos los servicios públicos (gas, electricidad, agua y vapor) deben estar APAGADOS para el equipo en cuestión y se debe seguir el procedimiento de cierre de operaciones de acuerdo con las prácticas aprobadas por la OSHA.

Los Representantes de Servicio calificados y autorizados de Cleveland Range, LLC tienen la obligación de actualizar constantemente sus conocimientos, destrezas, materiales y equipamiento.

# **FOR YOUR SAFETY / POUR VOTRE SÉCURITÉ /**

## **PARA SU SEGURIDAD**

### **FOR YOUR SAFETY**

Do not store or use gasoline or any other flammable liquids and vapours in the vicinity of this or any other appliance.

**WARNING:** Improper installation, operation, adjustment, alteration, service, or maintenance can cause property damage, injury or death. Read the installation and operating instructions thoroughly before installing, operating, or servicing this equipment.

Do not spray aerosols in the vicinity of this appliance while it is in operation.

This appliance is not to be used by persons with reduced physical, sensory, or mental capabilities, or lack of experience and knowledge, unless they have been given supervision or instruction concerning use of the appliance by a person responsible for their safety.

This appliance is not for use by children, and they must be supervised not to play with it.

Retain this manual for your reference.

### **POUR VOTRE SÉCURITÉ**

Ne pas entreposer ou utiliser d'essence ou d'autres liquides ou vapeurs inflammables à proximité de cet appareil ou de tout autre appareil.

**AVERTISSEMENT :** Toute mauvaise pratique en matière d'installation, de fonctionnement, de réglage, de modification, d'entretien ou de maintenance peut causer des dommages matériels, des blessures ou la mort. Lisez la totalité des instructions d'installation et d'utilisation avant d'installer, d'utiliser ou d'entretenir cet équipement.

Ne pas pulvériser des aérosols dans le voisinage de cet appareil alors qu'il est en fonctionnement.

Cet appareil ne doit pas être utilisé par des personnes dont les capacités physiques, sensorielles ou mentales sont réduites, ou des personnes dénuées d'expérience ou de connaissance, sauf si elles ont pu bénéficier, par l'intermédiaire d'une personne responsable de leur sécurité, d'une surveillance ou d'instructions préalables concernant l'utilisation de l'appareil.

Conservez ce manuel pour votre référence.

### **PARA SU SEGURIDAD**

No guarde ni use gasolina o cualesquiera otros líquidos o vapores inflamables en las cercanías de éste o cualquier otro aparato.

**ADVERTENCIA:** La indebida instalación, operación, ajuste, modificación, servicio o mantenimiento puede ocasionar daños a la propiedad, lesiones o muerte. Lea detenidamente las instrucciones de instalación y de operación antes de instalar, poner a funcionar o dar servicio a este equipo.

No pulverice aerosoles en las proximidades de este aparato mientras está en funcionamiento.

Este aparato no debe ser utilizado por personas con capacidades físicas, sensoriales o mentales reducidas, o que no tengan la experiencia y los conocimientos adecuados, a menos que estas personas hayan recibido supervisión e instrucciones en cuanto al uso del aparato por la persona responsable de la seguridad de ellas.

Guarde este manual para su referencia.

## WARNING / AVERTISSEMENT / ADVERTENCIA



Inspect unit daily for proper operation. / Inspecter le bloc quotidiennement pour garantir le fonctionnement normal. / Inspeccione diariamente el funcionamiento correcto de la unidad.



Heavy. / Lourd. / Pesado.

Team or mechanical lift. / Levage en équipe ou mécanique. / Levantamiento en equipo o mecánico.



Surfaces may be extremely hot! Use protective equipment. / Les surfaces peuvent être extrêmement chaudes! Utiliser des équipements de protection. / ¡Las superficies pueden estar muy calientes! Utilice equipo protector.



Do not climb, sit, or stand on equipment. / Il ne faut pas monter, s'asseoir ni se tenir debout sur l'équipement. / No subirse, ni sentarse ni pararse sobre el equipo.



Do not remove guards or operate without them. / Ne pas supprimer les gardes ou fonctionner sans eux. / No retire los guardias ni funcionar sin ellos.



Keep hands away from moving parts and pinch points. / Tenir les mains à l'abri des pièces mobiles et des angles. / Mantenga las manos lejos de las piezas móviles y los puntos de presión.



Hot product and surfaces. / Produit et surfaces chaudes. / Producto y superficies calientes.



Keep clear of pressure discharge. / Se tenir hors de portée de la purge des soupapes de surpression. / Manténgase alejado de la descarga de presión.

Do not touch. / Ne pas toucher. / No la toque.



Unit must be anchored as per manual. / Unité doit être ancrée selon les directives du manuel. / Unidad debe estar fijado según el manual.



Floor may become slippery from product spillage. / Déversement de produit peut causer de plancher à être glissant. / Derrame de producto puede causar piso a ser resbaladizo.



Have a qualified service technician maintain your equipment. / Demandez à un technicien en entretien et en réparation qualifié d'effectuer l'entretien de votre équipement. / Haga que un técnico de servicio calificado mantenga su equipo.



Shut off power at main fuse disconnect prior to servicing. / Couper l'alimentation sur le principal fusible sectionneur avant l'entretien. / Apague la alimentación eléctrica en el fusible desconector principal antes de darle servicio.



Ensure equipment is at room temperature and pressure gauge is showing zero or less prior to removing any fittings. / S'assurer que le chaudron se trouve dans une température ambiante et que le manomètre affiche zéro ou moins avant de déposer les raccords. / Asegúrese de que la marmita está a temperatura ambiente y el manómetro está mostrando cero o menos antes de quitar cualquier accesorio.



Appliance must not be supplied through an external switching device that is regularly switched on and off. / L'appareil ne doit pas être alimenté par un interrupteur externe régulièrement allumé et éteint. / El aparato no debe ser alimentado a través de un dispositivo de conmutación externo que se encienda y apague periódicamente.

**OPERATION, INSTALLATION & MAINTENANCE MANUAL STEAMCRAFT MODEL  
24CDP10**

**Table of Contents**

<b>CHAPTER 1 GENERAL INFORMATION.....</b>	<b>5</b>
A.    Laws, Codes, and Regulations.....	5
B.    Operational Safety.....	5
C.    Inspect for Shipping Damage .....	5
<b>CHAPTER 2 PRODUCT INFORMATION.....</b>	<b>6</b>
A.    Product Information .....	6
B.    Model Numbers and Serial Numbers.....	6
C.    Product Information Plate .....	6
D.    Product Views .....	7
<b>CHAPTER 3 INSTALLATION .....</b>	<b>9</b>
A.    Select a Location.....	9
B.    Position and Level the Appliance.....	9
C.    Slide Racks (Pan Racks).....	10
D.    Steam Supply .....	10
E.    Water Supply.....	10
F.    Electric Power Supply.....	12
G.    Free Air Vented Drain Line .....	12
H.    Installation Checklist.....	14
<b>CHAPTER 4 COOKING WITH THE 24CDP10.....</b>	<b>15</b>
A.    Steam Pressure Gauge .....	15
B.    Cooking Procedure.....	15
<b>CHAPTER 5 EASY TIMER OPERATING INSTRUCTIONS.....</b>	<b>17</b>
A.    Main External Power Switch .....	18
B.    Inspecting the Cooking Compartment.....	18
C.    Power ON (Automatic Preheat) .....	18
D.    Preheat Steamer .....	19
<b>CHAPTER 6 SHUTDOWN AND CLEANING PROCEDURE.....</b>	<b>20</b>
A.    Shutdown and Cleaning .....	20
<b>CHAPTER 7 OPERATING TESTS AND FINAL SHUTDOWN PROCEDURE .....</b>	<b>21</b>
A.    Startup Procedure with the Appliance De-Energized .....	21
B.    Operating Test Procedures.....	21
C.    Optional Compartment Door Steam Shut Off Switch (SCS).....	22
D.    Function Test for the Optional Steam Shut Off Switch.....	22
<b>CHAPTER 8 PREVENTATIVE MAINTENANCE .....</b>	<b>24</b>
A.    General Information.....	24
B.    Maintenance and Service Records .....	24
C.    Daily Maintenance.....	24
D.    Weekly Maintenance .....	24
E.    Yearly Maintenance.....	24
<b>CHAPTER 9 OPERATOR'S TROUBLESHOOTING GUIDE.....</b>	<b>25</b>

# CHAPTER 1 GENERAL INFORMATION

---

## A. Laws, Codes, and Regulations

This equipment should be installed only by qualified, professional plumbers, pipe fitters, and electricians.

1. The installation of this appliance must conform with:
  - a. The National Electrical Code, ANSI/NFPA 70 (latest edition), or the Canadian Electrical Code, CSA C22.2, as applicable.
    - When installed, the appliance must be electrically grounded in accordance with the above.
  - b. The *Food Code* (latest edition) of the Food and Drug Administration (FDA).
2. This equipment is to be installed to comply with the applicable federal, state, or local plumbing codes.
3. This appliance is attached to a pressurized steam source (boiler). In addition to compliance with all applicable codes and regulations, compliance with all laws regarding Boilers and Pressure Vessel, including, but not limited to, operator training, and obtaining permits and licenses is required before starting the Boiler and the attached appliances.
4. Installation instructions must be read in their entirety before starting installation.
5. Install this appliance according to the policies and procedures outlined in this manual.
6. Installation must comply with **all** local fire and health codes.
7. Clean, non-toxic, uncontaminated, potable steam is required for all “Direct Steam” steamers.

### **DANGER**

Improper installation, adjustment, alteration, service, or maintenance of this appliance, or installation of a damaged appliance can result in DEATH, INJURY, EQUIPMENT DAMAGE, and void the warranty.

**NEVER** install damaged appliances, equipment, or accessories.

**ALWAYS** have installation and service performed by qualified Cleveland Range authorized personnel.

## B. Operational Safety

The Operational Safety section outlines minimum safety policies and procedures for operating one or more Cleveland Range appliances.

1. Do not store anything on top and underneath the appliance.
2. KEEP THE APPLIANCE AREA FREE AND CLEAR OF COMBUSTIBLES.
3. Proper air supply for ventilation is REQUIRED for and CRITICAL to safe, efficient operation of this appliance.
4. Place non-slip draining anti-fatigue mats rated for use in wet, greasy, or dry work areas on the floor in front of the appliance and other locations as needed. Obtain the best mats for your needs from your local supplier.
5. Wear BOOTS appropriate to the work area to help protect feet, and to help prevent slips and falls.
6. Allow only qualified Cleveland Range authorized service representatives to service the appliance.
7. Use only factory authorized repair parts.
8. Maintain written records of appliance service, maintenance, and repair. See Chapter 8.

### **DANGER**

Operating this appliance out of level can cause DEATH, INJURY, and EQUIPMENT DAMAGE.

This appliance must be level both front-to-back and side-to-side in all installations. NEVER operate this appliance out of level.

If this appliance is suspected to be out of level, shut it down at once and call your qualified Cleveland Range authorized service agency immediately.

## C. Inspect for Shipping Damage

If the appliance is damaged or damage is suspected:

1. Submit a Damage Claim to the shipper and inform your dealer immediately.
2. Inform Cleveland Range in writing within three (3) days.

## CHAPTER 2 PRODUCT INFORMATION

---

### A. Product Information

- This manual covers the operation of 24CDP10 SteamCraft Steam Cookers (steamers) and their standard features and options.
- Other than the selection of options, there are presently no significant design, parts, or operating differences among appliances with these model numbers.
- Figures 2-1 and 2-2 illustrate the major external features of 24CDP10's.

### B. Model Numbers and Serial Numbers

1. Cleveland Range, LLC assigns two product identification numbers to each appliance: a model number and a serial number.
2. Please provide the model number and serial number when you contact Cleveland Range or a qualified Cleveland Range authorized service representative.

- Model Number \_\_\_\_\_

(Write the Model Number of your appliance here)

- Serial Number \_\_\_\_\_

(Write the Serial Number of your appliance here)

### C. Product Information Plate

The Product Information Plate on the left side of the appliance lists:

- Model
- Serial number
- Power and wiring requirements

D. Product Views

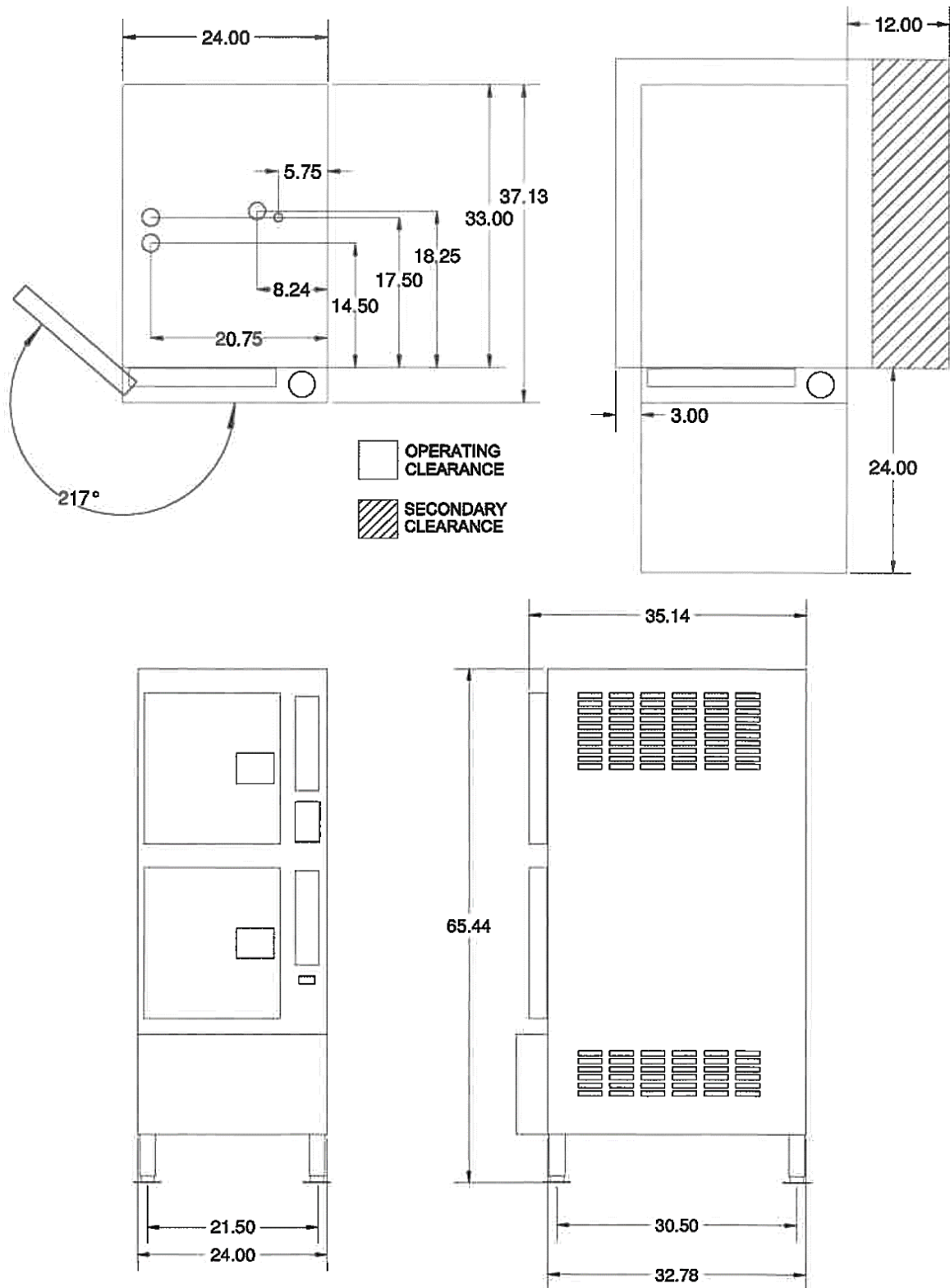

**Figure 2-1**  
**24CDP10 Product Views**  
**Plan, Front, and Side Views**  
**Dimensions in Inches**

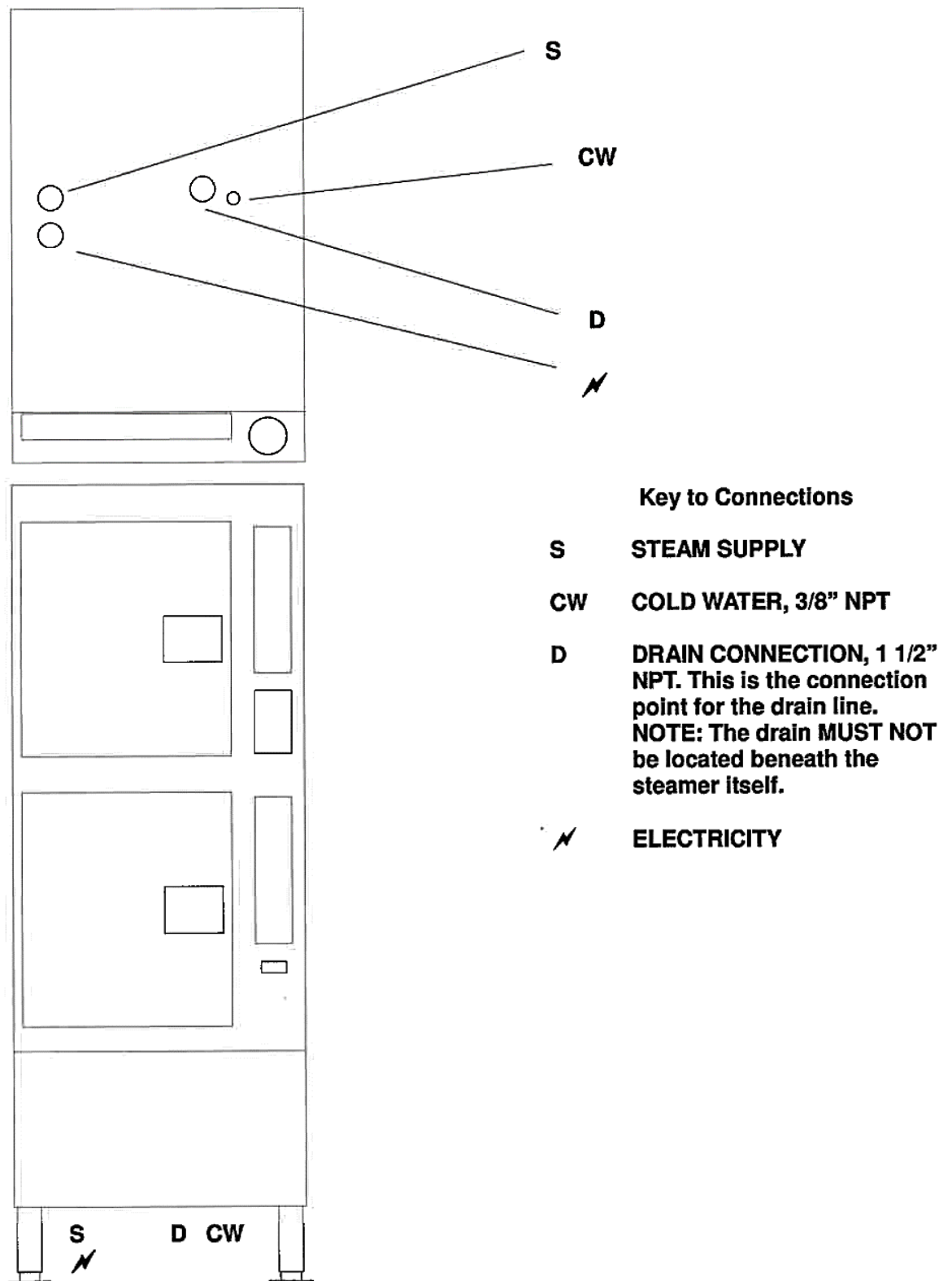

Figure 2-2  
24CDP10  
Utility Locations

## CHAPTER 3 INSTALLATION

### DANGER

Operating this appliance out of level can cause DEATH, INJURY, and EQUIPMENT DAMAGE.

This appliance must be level both front-to-back and side-to-side in all installations.

NEVER operate this appliance out of level.

If this appliance is suspected to be out of level, shut it down at once and call your qualified Cleveland Range authorized service agency immediately.

#### A. Select a Location

1. For safe and efficient operation:
  - a. Installation must comply with all local fire and health codes.
  - b. The location selected must be capable of supporting this appliance.
    - The operating weight of a 24CDP10 is 550 pounds.
  - c. Position the appliance so it will not tip or slide.
  - d. The operating surface must be level enough to allow leveling with the adjustable legs. This appliance **MUST** be level both front to back and side to side before operation.
  - e. A suitable drain must be available within 12 feet of this appliance. Do NOT install the appliance directly over a drain.
  - f. The location must include space for Operating and Service/Secondary Clearances and the Exhaust Hood. See Figure 2-1.

### WARNING

All clearance requirements above, below, and around this appliance are the same for non-combustible locations as for combustible locations.

Failure to maintain required clearances and additional distances as needed can result in INJURY and EQUIPMENT DAMAGE.

Consult manufacturers' literature and sales and service agencies as needed.

- g. KEEP THE APPLIANCE AREA FREE AND CLEAR OF COMBUSTIBLES.
- h. Proper air supply for ventilation is REQUIRED for and CRITICAL to safe, efficient operation of this appliance.
- i. Make sure the air vents of this appliance are not blocked with or by anything.
- j. Allow for sufficient extra distance if a "high heat source," e.g. a broiler, is located next to this appliance. Contact Cleveland Range for recommendations.
- k. Do NOT install this appliance directly over a drain. Steam rising up out of the drain will adversely affect operation, hamper cooling air circulation, and damage electrical and electronic components.

#### B. Position and Level the Appliance

1. Move the appliance into position.
2. Place a level along the bottom edge of the appliance.
3. Use the adjustable legs of the appliance to level it front-to-back and side-to-side.

### C. Slide Racks (Pan Racks)

1. Refer to Figure 3-1. Each rack has four loops: two top and two bottom. Hold the slide rack so the ends of the hanger loops are towards the compartment wall.
2. Slide one rack into compartment with the loop side closest to the compartment wall and rack slots horizontally.
3. Hook the loops over the top and bottom pins.
4. Repeat steps 1, 2, and 3 for the other racks.

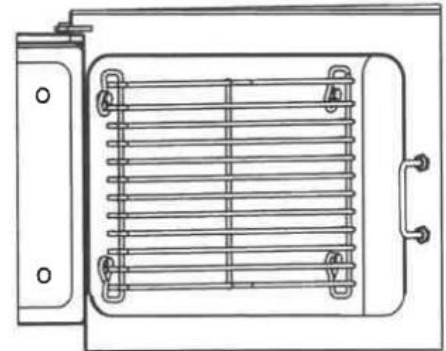

**Figure 3-1**  
**Slide Rack Installation**

### D. Steam Supply

1. Clean, non-toxic, uncontaminated, potable steam is required for all "Direct Steam" steamers.
2. The Installer/Owner is responsible for furnishing a minimum ¾" IPS steam line providing potable steam at a pressure between 20 and 50 psi.
3. Install a pressure reducing valve, if needed. Contact Cleveland Range or your qualified Cleveland Range authorized service center for more information.

### E. Water Supply

1. Water Supply Requirements

#### **CAUTION**

Using water not within the limits specified in this manual could void or reduce Cleveland Range's warranty coverage of the steamer.

- a) Water Quality

As with any steam generating equipment, poor water quality degrades the performance of the steamer.

Check the quality of supply water as described below before starting construction of the water supply lines. If a water treatment system must be installed to achieve acceptable water quality, install it before connecting the water supply lines to the steamer.

If softened or chlorinated water is used in this steam generator, a carbon type filter must be used for the water before it enters the steamer to remove Chlorine or other salts. If the water supply is treated or softened either by the Water Company or on the premises, it may contain chlorine or various salts. These additives are damaging to the steam generator. Salts and chlorine used to soften or treat water cause rapid scale buildup, and/or increased corrosion if allowed to flow into the steamer.

Contact a local water treatment specialist for an on-the-premises water analysis. The recommended minimum feed water quality requirements for the steamer are listed in Table 3-1.

**Table 3-1. Minimum Water Quality Requirements**

#### Scale Forming Factors

Total Dissolved Solids	less than 60 parts per million
Silica	less than 13 parts per million
Alkalinity	less than 20 parts per million

#### Corrosion-Causing Factors:

Free Chlorine	less than 0.5 parts per million
---------------	---------------------------------

Chloride	less than 30 parts per million
PH factor	greater than 7.5

b) Water Supply System

Provide a water supply system that fulfills the requirements of the limits listed in Table 3-1. The supply must provide a minimum dynamic pressure of 35 psi (2.4 kg/cm<sup>2</sup>) and a maximum static pressure of 60 psi (4.1 kg/cm<sup>2</sup>).

- If analysis shows that the supply water is NOT within the required limits, either a water treatment system and/or carbon filter must be installed in the line feeding the steam generator or the frequency of maintenance, cleaning, and descaling must be increased beyond that recommended in the maintenance schedule (Chapter 8).

2. Connect the Water Supply Lines

- The Installer/Owner is responsible for the water connection of this appliance.
- This appliance is to be installed to comply with all applicable federal, state, or local plumbing codes.
- **Connect this appliance to COLD WATER.** The condenser system will not work properly if connected to HOT or WARM water.
- a. **Water supply must have a minimum dynamic (flow) pressure of 35 psi (2.4 kg/cm<sup>2</sup>) and a maximum static pressure of 60 psi (4.1 kg/cm<sup>2</sup>).**
- b. **If the static pressure is above 60 psi, a pressure regulator must be used and set at approximately 50 psi. Pressure above 60 psi can damage solenoid valves.**
  - See Figure 3-2.

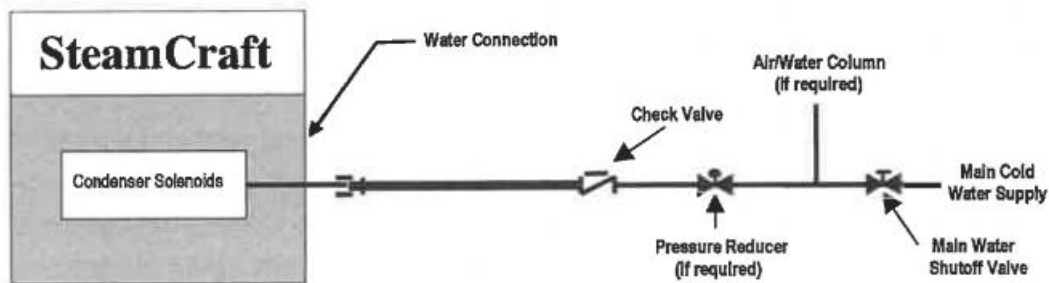

**Figure 3-2**  
**Cleveland Range Single Water Supply Arrangement**

c. Installation Requirements:

- Apply non-hardening pipe thread sealant to threaded connections.
- The 24CDP10 has a 3/8" NPT female fitting on its underside for the condenser. See Figure 2-2.
- Install a manual water shut-off valve (Main Water Shutoff Valve) (not provided) between the cold water supply line(s) and the appliance.
- The National Sanitation Foundation (NSF) requires installation of a check valve (or other approved anti-backflow/anti-siphon device) (not provided) in all supply lines in accordance with and as required by local, state, and national health, sanitation, and plumbing codes.
- A 40 mesh water strainer (dirt filter), Cleveland Range Part Number [19870](#), is factory installed.
- Flush the water supply line before connecting the line to the appliance.

1) Test Water Supply Lines

- a. Check all connections for proper tightness.
- b. Remove the side panels to inspect the water connections inside the appliance.
- c. Open the water supply valve.
- d. Check the line and connections for leaks, both inside and outside the appliance.

**F. Electric Power Supply**

The electrical supply must match the power requirements specified on the steamers rating plate and be made in accordance with the following requirements.

1. The steamer must be grounded and have the electrical power lines installed in accordance with local codes and/or the National Electric Code, ANSI/NFPA No. 70-LATEST EDITION (USA) or the Canadian Electrical Code, CSA C22.2, as applicable. The wiring diagram is located on the back of the lower front panel.
2. Power connection
  - This unit is not suitable for connection to a GFCI (Ground fault Circuit Interrupter).
  - Cleveland Range recommends that the unit be connected to the electrical system, using a flexible conduit system compliant with the applicable codes.
3. A main disconnect switch and a separate fuse or breaker should be installed near the unit as shown in Figure 3-3. Throughout the remainder of this manual the fused disconnect switch is referred to as the main external power switch.
4. Refer to the connection diagrams in Figure 3-4 and connect the wires to the terminal block and ground connector accordingly.

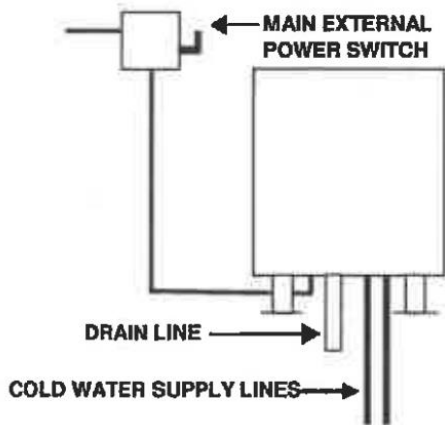

**Figure 3-3**  
**Electrical Layout**

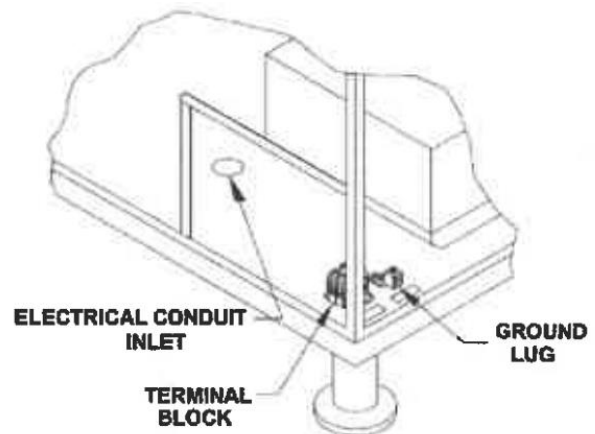

**Figure 3-4**  
**Hardwire Connection**

**G. Free Air Vented Drain Line**

**⚠ DANGER**

DEATH, INJURY, EQUIPMENT and PROPERTY DAMAGE will result from improper installation of drain outlet lines. Install free air vented drain lines as described in this manual.

**NOTICE:** Furnishing and installing drain lines and drainpipe is the responsibility of the Installer/Owner.

**The following restrictions and requirements are critical to the safety of personnel and equipment, and must not be violated under any circumstances:**

1. The drain lines must be installed in compliance with the *Food Code* (latest edition) of the Food and Drug Administration (FDA), and any other applicable national, state, or local codes and regulations.
2. The drain line must be free air vented, have gravity flow from the appliance, and terminate outside the perimeter of the appliance.
3. Free air venting requires a minimum 1" clearance between the end of the drain line and the top of the floor drain. See Figure 3-5.
4. Do NOT install the appliance directly over a drain. Steam rising up out of the drain will adversely affect operation, hamper cooling air circulation, and damage electrical and electronic components.
5. Do NOT connect the appliance's drain connection to any drain material that cannot sustain 180°F.
6. Do NOT connect any other drain from any other equipment to the drain line of this appliance.
7. Do NOT connect the drain outlet extension line directly into a floor drain or a sewer line.
8. Do NOT connect this appliance's drain directly to drains or to the plumbing of any other equipment.
9. Do NOT install a trap or shutoff in the drain line.

**10. Drainpipe Size and Length Guidelines:**

- **Do NOT make a drainpipe outlet extension more than 12 feet long.**
- **Do NOT use more than three elbows.**
- **Up to 6' pipe:** 1 ½ -inch pipe and fittings are acceptable.
- **Up to 2 elbows:** 1 ½-inch pipe and fittings are acceptable.
- **6' to 12' pipe:** 2-inch pipe and fittings are required.
- **3 elbows on any extension:** 2-inch pipe and fittings are required.

11. Refer to Figure 3-5: Connect the drain to the appliance.

- a. While assembling the pipes and fittings of the drain outlet extension, use non-hardening pipe thread sealant.
- b. Thread fittings together FINGER TIGHT ONLY! DO NOT USE A WRENCH!

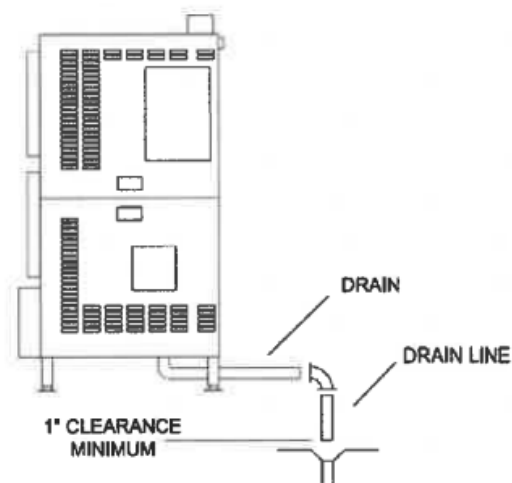

**Figure 3-5  
Typical Drain Layout**

**H. Installation Checklist**

**Installation Checklist**

<b>TASK</b>	<b>REFERENCE Chapter Number</b>	<b>COMPLETED (initial and Date)</b>
<b>Preparation</b>		
Check Operating Location Clearances	Chapter 2 Section D	
Test Supply Water Quality	Chapter 3 Section E	
Water Supply Requirements Met	Chapter 3 Section E	
Electric Power Requirements Met	Chapter 3 Section F	
<b>Installation</b>		
Check Level Front-to-Back and Side-to-Side	Chapter 3 Section B	
Check Drain Line Connection	Chapter 3 Section G	
Check Electrical Supply Connection	Chapter 3 Section F	
Check Water Supply Connection	Chapter 3 Section E	
Leak Test Water Supply Lines	Chapter 3 Section E	

**Notes:**

### **⚠ DANGER**

**Do NOT breathe steam, hot air or condensate. DEATH or INJURY will result.**

### **⚠ WARNING**

**Hot air, steam, and condensate will cause burns and scalds.**

To help prevent burns and scalds when opening steamer doors: always stand to the hinge side and back from the doors, slowly open the door, and wait for the steam and heat to dissipate before reaching into the steamer.

**The steamer is a continuously operating appliance, so parts are ALWAYS HOT when the Main External Power Switch or the ON/OFF switch is in the ON position.**

When the ON/OFF switch is turned to the OFF position, the steamer will remain HOT for some time. Contact with hot surfaces and steam can cause burns and scalds. Avoid contact with hot surfaces and steam.

**If the steamer door is stuck shut: DO NOT force the door open.**

The door stuck shut may indicate a blocked drain. Hot water can fill the cooking compartment and spill out if the door is forced open causing injury and equipment damage.

If the steamer door is stuck shut:

- Turn OFF the steamer.
- Call a qualified Cleveland Range authorized service technician.
- Wait for the steamer to cool before servicing.

### **⚠ CAUTION**

**Some foods drip juices.** Use a solid catch pan under perforated pans when cooking food that drips juices. Dripping juices can cause burns and clog the drain.

Do NOT use oven racks that are bent or otherwise damaged in any way.

DO Insert pans and accessories LEVEL and INSIDE the oven racks.

Pans and accessories placed in damaged or out of level racks, or outside racks can tip and spill, causing burns, injuries and/or equipment damage.

#### **A. Steam Pressure Gauge**

- This gauge shows operating and unsafe pressure ranges. See Figure 4-1.
- If the pressure is too high or too low, turn the ON/OFF switch OFF and call a qualified Cleveland Range authorized service representative or Cleveland Range.

#### **B. Cooking Procedure**

##### **1. Before Cooking:**

- a. Inspect and clean the drain and the cooking compartment as required. See Chapter 6.
- b. Preheat: If necessary, preheat the cooking compartment.

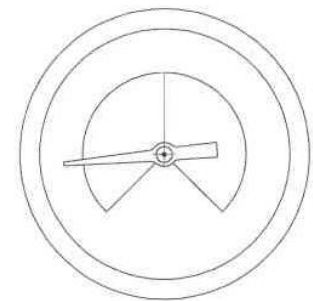

**Figure 4-1**  
**Steam Pressure Gauge**

- c. Slide pans of food into the slide racks in the cooking compartment
- d. Do not place pans or anything else on the bottom of the compartment.
- e. Close the compartment door.

**2. Refer to **Easy Timer Operating Instructions** in Chapter 5 to start cooking.**

- While cooking, occasionally check the water in the reservoir for food particles and oils. If the water is dirty or cloudy, change the water.
- The steamer compartment of the steamer is equipped with an automatic **door interlock switch** that turns off the heating elements and condenser when the door to the compartment is opened.

## **WARNING**

### **Burn and Scald Hazard**

Even though the heat shuts off as soon as the door is opened, it may take up to a minute for production of steam to end and residual steam in the system to clear from the cooking compartment.

To help avoid injury, always wait until the residual steam clears before reaching into the cooking compartment, and always wear dry heatproof gloves when reaching into the cooking compartment. Wet or damp gloves conduct heat and can cause burns when touching hot items.

**3. After Cooking:**

- a. If the appliance will be used again in a few minutes, shut door to maintain cooking compartment temperature.
- b. If another use is not planned for more than half an hour, leave the cooking compartment door open slightly.
- c. If the appliance will not be used again during this shift, go to Chapter 6.

## CHAPTER 5 EASY TIMER OPERATING INSTRUCTIONS

---



DIGITAL DISPLAY

CONTROL KNOB

Enabled with **TIMED** mode

**TIMER START/STOP BUTTON** in **TIMED** mode

**TIMED/MANUAL SWITCH BUTTON**

(Press for 5 sec)



ON-OFF SWITCH

### **⚠ CAUTION**

Press switch and button with fingertips only.

**INJURY** and **EQUIPMENT DAMAGE** can result from pressing switches and buttons with anything else.

### A. Main External Power Switch

Usually, the steamers main external power switch is left ON. If the main external power switch was left in the OFF position, turn it ON as follows.

1. Check that the water supply valves are open.
2. Turn the ON/OFF switch to the OFF position.
3. Refer to the main external power switch in Figure 5-1 and turn on electric power to the steamer.

### B. Inspecting the Cooking Compartment

At the back of the cooking compartment, a drain screen covers the drain (Refer to Figure 5-2). The screen prevents large food particles from entering and blocking the drain line. Any blockage of the drain line or screen can reduce drainage from the cooking compartment resulting in reduced cooking performance, equipment damage, and a hazard to the operator. A blocked or slow drain may cause:

- Hot water to collect in the compartment and spill out when the compartment door opens.
- Pressure fluctuations in the compartment, resulting in steam leaks around the door gasket, or compartment implosion.
- Reduced convection in the compartment, reducing cooking performance.

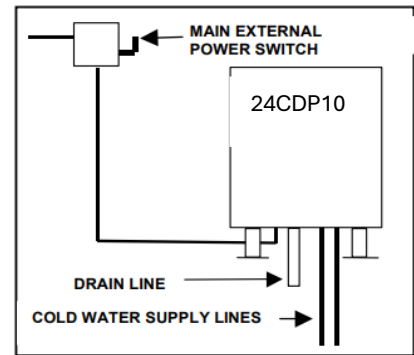

Figure 5-1 Main External Power Switch

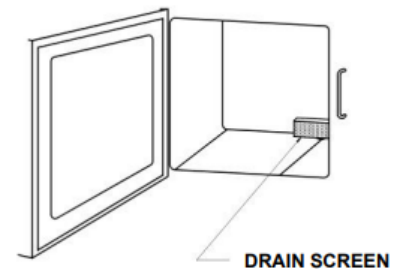

Figure 5-2  
Compartment Drain Screen

## ⚠ CAUTION

Steam leaks around the door, cooking compartment flooding, reduced cooking performance, and compartment implosion can be caused by a blocked drain or drain screen. Inspect and clean the drain and drain screen before each use.

Before every steaming operation, inspect the cooking compartment and remove any food scraps or debris from the racks, walls, and floor of the compartment. Pay attention to the drain and drain screen.

1. **DO NOT USE** the steamer if water stands in the drain opening. Arrangements must be made immediately to clean the drain in accordance with the instructions found in the **Preventative Maintenance and Troubleshooting** section of this manual.
2. Remove any food or debris that is blocking the drain or screen.
3. Be sure the screen covers the drain. The screen prevents large pieces of food from entering and blocking the drain.

### C. Power ON (Automatic Preheat)

1. Turn ON power to the steamer by turning on the ON-OFF switch. The digital display lights.
2. Switch to TIMED mode and set the timer to 05:00 and press the “TIMER-START/STOP” button. Steam will fill the cavity.
3. Timed Mode (with “SURE COOK” mode feature)
  - a) Select cooking time using “Control Knob”.
  - b) Press “TIMER-START/STOP” button to start cooking.
  - c) “SURE COOK” illuminates on digital display once the compartment reaches 193°F (90°C).
  - d) Timer then starts to countdown until it reaches 00:00.

- e) Steamer will stop heating and require prompt when the timer reaches 0:00.
- 4. Manual Mode (Continuous Steaming)
  - a) Press and hold “TIMER-START STOP” button for 5 seconds until switches to Manual mode.
  - b) “MAN” will appear on the digital display when activated and control knob disabled.
  - c) Note: steamer will go into “Standby” mode if compartment isn’t opened for 60 minutes.
- 5. Changing from Manual to Times Mode
  - a) Press and hold “TIMER-START/STOP” button for 5 seconds until switches to TIMED mode.
  - b) “TIMED” will appear on the digital display.
  - c) Digital display will display 00:00, Control knob activated.
- 6. “Descale” Notification
  - a) Easy Timer comes with 400 hours operation for “Descaling Notification.”
  - b) After 400 hours, “DESCALE” appears on digital display for 5 seconds and will re-appear every 5 minutes.
- 7. Reset and Clear Descale Notification
  - a) Turn OFF main power with POWER SWITCH
  - b) Press and hold the “TIMER-START/STOP” Button
  - c) Power unit ON with main POWER SWITCH (with “TIMER START/STOP” Button held).
  - d) Wait 10 seconds to Reset/ Clearing Mode.
  - e) The Beeper starts beeping once every second.
  - f) Release the “TIMER-START/STOP” button.
  - g) Display will show “RST”.
  - h) Press the “TIMER-START/STOP” button to confirm resetting descale notification.
- 8. Program Number of Hours until Descale Notification
  - a) Turn OFF main power with POWER SWITCH.
  - b) Press and hold the “TIMER-START/STOP” Button.
  - c) Power unit ON with main POWER SWITCH (with “TIMER START/STOP” Button held).
  - d) Wait 20 seconds to enter Programming Mode (to change the Max number of hours)
  - e) The Beeper starts beeping twice every second.
  - f) Release the “TIMER-START/STOP” button.
  - g) Display will show past settings.
  - h) Turn knob to adjust the number of hours.
  - i) Press “TIMER-START/STOP” button to save number of hours for next descale notification.

#### D. Preheat Steamer

Preheat steamer to ensure productivity and consistency. **BEFORE PREHEATING:** Inspect and clean the compartment. After preheating, the compartment will be too hot to inspect and clean safely.

##### To preheat the steamer:

1. Close the steamer door and turn the steamer ON 15 minutes before cooking.
2. The steamer will heat to the standby temperature.

## CHAPTER 6 SHUTDOWN AND CLEANING PROCEDURE

### A. Shutdown and Cleaning

- Perform the Shutdown and Cleaning Procedure at the end of each shift or more often if needed.

### ⚠ WARNING

#### ELECTRIC SHOCK HAZARD

Do not clean this appliance with hoses or water jets. Doing so can cause **INJURY** and **EQUIPMENT DAMAGE**.

### ⚠ DANGER

#### HIGH HEAT HAZARD

Wait for this appliance to cool before cleaning. Attempting to clean a hot appliance can cause **DEATH**, **INJURY**, **BURNS**, and **SCALDS**.

#### Shutdown and Cleaning Procedure for the End of Each Shift:

1. Open the cooking compartment doors and allow the appliance to cool.
2. Remove the slide racks. Wash, and rinse them according to health and sanitation requirements.
3. Remove spilled food from inside the compartments. Use a soft bristle brush to remove stuck food.
5. Clean but do not remove drain screens.
6. Clean the interior of the compartment thoroughly.
  - Do NOT use abrasive cleaning compounds or steel wool.
7. Rinse the inside of the cooking compartments with clean water.
8. Clean the door gasket assemblies.
  - a. Remove the door gasket assembly (see Figure 6-1) by holding the gasket assembly at the side and lifting up and away from the door.
  - b. Wipe the gasket assembly with a damp cloth.
  - c. Wipe the inside of the door with a damp cloth.
  - d. Rotate the gasket assembly 180°. This helps the gasket last longer.
  - e. Replace the gasket assembly by sliding the retaining pins into the keyhole slots.
9. Replace the cleaned slide racks.
10. Wipe the exterior with a damp cloth.
11. Leave cooking compartment doors open until the next use to help prevent compartment odor buildup and help increase gasket life.

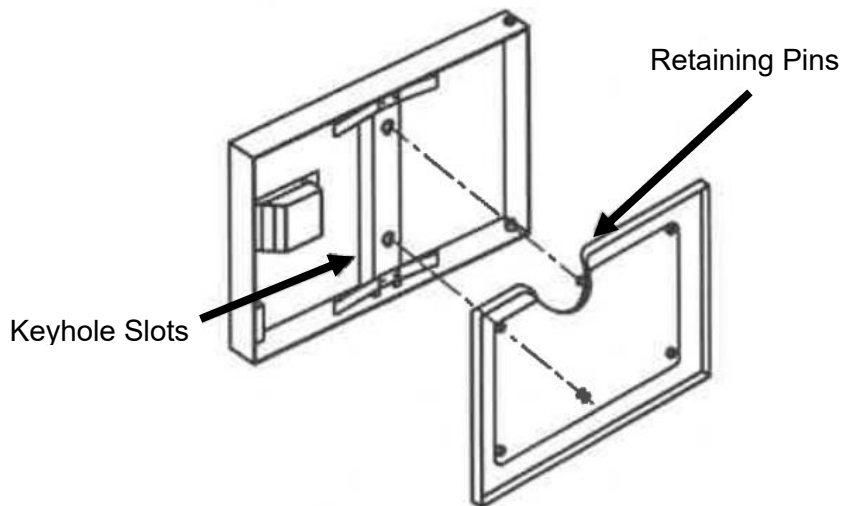

**Figure 6-1**  
**Door Gasket Assembly**

## CHAPTER 7 OPERATING TESTS AND FINAL SHUTDOWN PROCEDURE

---

### A. Startup Procedure with the Appliance De-Energized

1. Start with or the Main External Power Switch OFF.
2. Check the fuses or circuit breakers for proper size.
3. Make sure the water supply line valve is open.
4. Open the cooking compartment doors.
  - Check the proper installation of drain screens, slide racks, and door gasket assemblies.
  - Check that the drains are not blocked.
5. Shut the cooking compartment doors.
6. Control panel settings:
  - a. ON/OFF switch OFF.
  - b. TIMED/MANUAL mode to TIMED.
7. Go to B. “**Operating Test Procedures.**”

### **WARNING**

ELECTRIC SHOCK HAZARD DEATH, INJURY, or EQUIPMENT DAMAGE can result from touching any component inside this appliance when the power is connected.

Whenever possible disconnect the power while installing, servicing, or testing this appliance.

**When installation, service, or tests require power to be connected to this appliance: use extreme caution and every possible precaution and safety measure while testing or servicing this appliance.**

### B. Operating Test Procedures

1. Turn OFF the Main External Power Switch.
2. Turn OFF the ON/OFF switch.
3. Turn ON the Main External Power Switch.
  - a) Turn the ON/OFF switch ON. (Switch above Steam Pressure Gauge.)
    - The digital display lights.
  - b) Start a manual steaming cycle.
    - i. Set to MANUAL mode.
    - ii. The condenser solenoid clicks open, condenser flow starts, and water flows from the drain pipe.
    - iii. If no water flows from the drain, make sure the condenser water supply valve is open and the water lines are connected properly.
  - c) Steam enters the cooking compartment.
    - Water may drip from the nozzles until steam clears the lines.
  - d) The cooking compartments steam until turned OFF or set to TIMED mode with the timer zeroed.
  - e) Check for steam leaks around the door gasket.
  - f) Leave the ON/OFF switch in the ON position.
  - g) Set the Timer to 00:00 to stop steaming.
4. Turn the appliance OFF using the ON/OFF switch:

- The digital display turns OFF.
  - Automatic blowdown starts and runs for 3 minutes.
5. After blowdown ends:
- a) Turn OFF the Main External Power Switch.
  - b) Replace all panels and sheeting.
  - c) Turn ON the Main External Power Switch.

**C. General Information about the Steam Shut Off Switch**

- Steam Shut Off Switches (automatic steam cutoff switches) turn OFF the release of steam to a cooking compartment when the door to that compartment is opened.

<b>⚠ DANGER</b>
<p>BURN AND SCALD HAZARD WARNING FOR STEAMERS WITH COMPARTMENT DOOR STEAM SHUT OFF SWITCH (SCS):</p> <p><b>COMPARTMENT DOOR STEAM SHUT OFF SWITCHES ARE <u>NOT</u> INSTANT OFF!</b></p> <ul style="list-style-type: none"> <li>• Even though the release of steam from the boiler ends as soon as a door is opened, residual steam in the system may take up to a minute to clear from the steam lines and the cooking compartment.</li> <li>• To help prevent injury, follow all the standard precautions for opening the cooking compartment door and reaching into the cooking compartment.</li> </ul> <p>Failure to do so can result in death, burns, and scalds.</p>

- If a cooking compartment is opened and the other left closed, the closed cooking compartment continues to steam as normal.

<b>⚠ WARNING</b>
<p><b>BURN and SCALD HAZARD</b></p> <p>Residual steam in the system may take up to a minute to clear from the steam lines and the cooking compartment.</p> <p>Always wait until this residual steam has cleared before reaching into the cooking compartment.</p> <p>Reaching into a cooking compartment while steam is being released or clearing the steam lines can cause BURNS and SCALDS.</p>

**D. Function Test for the Optional Steam Shut Off Switch**

- Perform this test after the appliance passes Initial Setup, and Operating Test, and the appliance is ready for use.
1. Start the appliance with both cooking compartments in MANUAL mode.
  2. Wait for the cooking compartments to reach cooking temperature, indicated by the “SURECOOK” message going out.
  3. Stand to the hinge side and back from the upper door and carefully open the upper door.
  4. Steaming stops within a minute.
  5. If steaming does not stop within a minute: Shut down the appliance and call your qualified Cleveland Range authorized service representative.
  6. Leave the upper door open and let the cooking compartment cool for three minutes.
  7. Close the upper compartment door. Steaming starts and the cooking compartment reaches cooking temperature, and the “SURECOOK” message goes out.

8. If steaming does not start: Shut down appliance and call your qualified Cleveland Range authorized service representative.
9. Repeat this test with the lower cooking compartment door.
10. Repeat this test with both cooking compartment doors at the same time.

## CHAPTER 8 PREVENTATIVE MAINTENANCE

---

### A. General Information

- Follow the maintenance instructions and schedules to help keep the appliance working properly.
- Increase the frequency of maintenance as needed depending on use and water quality.
- Contact your qualified Cleveland Range authorized service agency or Cleveland Range for more information about maintenance scheduling, products, and services.

### B. Maintenance and Service Records

1. Make a file just for maintenance records.
2. Keep a written record of daily, weekly, monthly, and yearly maintenance, service, and repair. Each record must include at least:
  - The date of the service, maintenance, or repair.
  - A description of the service, maintenance, or repair performed.
  - Copies of purchase order(s) and invoice(s) for repair parts and service, maintenance, or repair. Include part numbers, if applicable.
  - The name and signature of the person performing the service, maintenance, or repair.

### C. Daily Maintenance

#### 1. Clean the Appliance

- Clean the interior and exterior of the appliance. Follow the instructions in Chapter 6.

### D. Weekly Maintenance

#### 1. Clean the Cooking Compartment Drains

- Blockage of the drain line can cause pressure buildup in the compartment(s) resulting in steam leaks around the door gasket(s), reduced performance, and compartment implosion.

#### 2. To Inspect the Drain Screens and the Drain Lines for Blockage

- a. Clean the cooking compartment and drain screens. Follow the instructions in Chapter 6.
- b. Rotate the drain screen 90 degrees to inspect the drain opening.
- c. Clean the opening and put the screen back into their operating position.
- d. Pour a quart of water into the cooking compartment. If the water drains slowly or stands, clean the cooking compartment drains with a NSF/FDA approved drain cleaner.
  - Follow the instructions of the drain cleaner manufacturer.
  - Flush the cooking compartments and drains with clean water.

### E. Yearly Maintenance

#### 1. Clean the Water Line Strainer

- Clean the water line strainer at least once a year. See Figure 8-1.

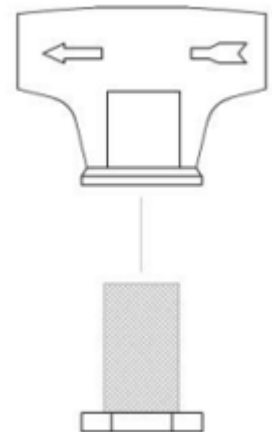

**Figure 8-1**

**Water Line Strainer**

**Actual Sizes and Proportions  
May Vary**

## CHAPTER 9 OPERATOR'S TROUBLESHOOTING GUIDE

The troubleshooting Guide is a list of symptoms of problems that may occur during routine operation.

- “Problem” (left column) lists common operating problems.
- “Possible Cause” (center column) lists causes of problems in the order they should be checked.
- “Remedy/Reference” (right column) lists fixes for problems from easiest to hardest.
- “Notes” in “Remedy/Reference” column are at the end of the Troubleshooting Guide.

### ATTEMPTING TO REPAIR OR CORRECT PROBLEMS REQUIRING A QUALIFIED CLEVELAND RANGE AUTHORIZED SERVICE REPRESENTATIVE VOIDS THE WARRANTY

PROBLEM	POSSIBLE CAUSE	REMEDY/REFERENCE
Digital display does not turn ON when ON/OFF switch is in the ON position.	Power turned OFF at main external power switch.	Turn ON power at Main External Power Switch.
	Inoperative controls.	See Note 1.
	Inoperative solenoids or controls.	See Note 1.
	Inoperative controls.	See Note 1.
Abnormal amount of steam coming from drain.	Hot water instead of cold water connected to condenser fitting.	Make proper connections. See section on Water Supply. See Note 3.
	Water supply to condenser turned off.	Open water supply valve(s).
	Condenser water line strainer is clogged.	Clean out water line strainer.
	Water supply line to the condenser blocked, broken, or leaking.	Water supply line needs repair or replacement. See Note 1.
	Insufficient water pressure. Inadequately sized water supply system.	See Note 3.
	Inoperative condenser solenoid.	Solenoid needs replacement. See Note 1.
	Inoperative controls.	Turn OFF power at Main External Power Switch. See Note 1.
Steam and/or water draining around compartment door.	Drain covered, blocked, or clogged.	Uncover, remove block, or clean drain with NSF/FDA approved drain cleaner.
	Condenser inoperative.	See Note 1.
	Door gasket or door parts worn.	See Note 1.
	Appliance not level.	See Note 2.
Steam flow does not stop when TIMER stops.	Operating in Manual Mode.	Switch to Timed Mode.
	Steam solenoid stuck open.	Turn OFF power at Main External Power Switch. See Note 1.
	Inoperative controls inside cabinet.	Turn OFF power at Main

		External Power Switch. See Note 1.
Water leaking from bottom of cabinet.	Broken or loose plumbing inside appliance cabinet.	Turn OFF power at Main External Power Switch. Close Main Water Shutoff Valve. See Note 1.
Water leaking from water pipes or drain lines.	Plumbing needs repair.	See Note 3.
Compartment bottom dirty with food drippings.	Juices and/or food leaking from pans.	Put a solid pan under perforated pans to catch drippings. Put less food in pan.
Food takes too long to cook.	Pans too close to the bottom of the cooking compartment.	Put pans in racks near top of cooking compartment.
	Hot water connected to condenser line.	Make proper connections. See section on Water Supply. See Note 3.
	Compartment overloaded with too much food.	Put less food into pan. Use fewer pans.
	Suggested cooking times are usually listed for cooking at sea level.	Extend cooking times for altitudes above 2500 feet.
	Condenser blocked.	See Note 1.
Easy Timer display has noise/disruptions.	Power surge/not clean power.	Recommended power surge bar to resolve rare EMI/power disruptions.
Easy Timer button does not respond	If Easy Timer display is ON, then the button membrane is broken.	See Note 1.
	If Easy Timer display is OFF, then wiring has been damaged.	See Note 1.

## Notes

1. If the problem is inside the appliance, call a qualified Cleveland Range authorized service representative or Cleveland Range (Please have the model number and serial number ready when calling). Cleveland Range will not pay for warranty repairs by unauthorized maintenance and repair centers.
2. Proper installation of the appliance is the responsibility of the Owner-User. Refer to the Warranty.
3. Repairs to external plumbing should be done by a Licensed Plumber.
4. To restart the unit, follow the Start-Up instructions in this manual.
5. Repairs to external wiring should be done by a Licensed Electrician.
6. For more information on products and services, contact your nearest Authorized Sales Representative.
7. Call Cleveland Range at 1-844-724-CARE for preventative maintenance programs, descaling kits, descaling information, and water treatment systems.
8. To evaluate whether this appliance is operating at normal cooking performance, conduct the Egg Test.

NOTE: This test is not valid for pressure steamers.

- a. Place a perforated steam table pan in the middle rack position in the cooking compartment. Turn ON the appliance and set it to MANUAL Mode so that steam is produced.

- b. Preheat the cooking compartment for 10 minutes.
- c. After the compartment is preheated, follow the instructions below.
  - 1) Place a fresh egg in a perforated pan and slide the pan into the cooking compartment.
  - 2) Close the door and set the timer as directed by the size chart below.

<b>Egg Size</b>	<b>Time</b>
Medium	12 minutes
Large	14 minutes
Extra Large	14 minutes

- 3) When time is complete, carefully remove the egg and place it in a container.
  - 4) Run cold water over the egg for 5 minutes.
  - 5) After cooling, crack the eggshell and peel the egg.
  - 6) A properly operating steamer produces a perfect hard-boiled egg.
9. When opening a cooking compartment door, especially when water or steam leaks around gasket, heed the warning below:

## **WARNING**

### **BURN, SCALD and EQUIPMENT DAMAGE HAZARD**

If the drain is blocked, hot water can fill the cooking compartment and spill out when the cooking compartment door is opened.

Signs of blocked drains include steam or water leaks around the cooking compartment door, and reduced cooking performance.

To help avoid injury:

- Stand on the hinge side and away from the appliance and slowly open the cooking compartment door.
- Inspect the drain(s) before each use and clean them if needed.

Failure to follow these precautions can cause BURNS, SCALDS, and EQUIPMENT DAMAGE.

10. Order replacement descale caps and gaskets from a Cleveland Range authorized maintenance and repair center.

# Cleveland

Cleveland Range, LLC  
760 Beta Drive, Unit D  
Mayfield Village, Ohio 44143  
216.481.4900  
800.338.2204

---

---

Every new piece of Welbilt Foodservice equipment comes with KitchenCare® and you choose the level of service that meets your operational needs from one restaurant to multiple locations

**StarCare** – Warranty & lifetime service, certified OEM parts, global parts inventory, performance audited

**ExtraCare** – CareCode, 24/7 Support, online/mobile product information

**LifeCare** – Install & equipment orientation, planned maintenance, KitchenConnect™, MenuConnect®

**Talk with KitchenCare®** • 1-844-724-CARE • [www.mtwkitchencares.com](http://www.mtwkitchencares.com)



To learn how Welbilt Foodservice and its leading brands can equip you, visit our global web site at [www.welbilt.com](http://www.welbilt.com), then discover the regional or local resources available to you.

©2016 Welbilt Foodservice except where explicitly stated otherwise. All rights reserved. Continuing product improvement may necessitate change of specifications without notice.