



Visit www.clevelandrange.com to locate a service or sales representative in your area.

Cleveland

Gemini

Dual Gas Steam Generator & Convection Steamer

Operation, Installation & Maintenance Manual

This manual is updated as new information and models are released. Visit our website for the latest manual.

MODELS:

24CGA6.2S
24CGA10.2
24CGA10.2ES

For your future reference.

Model # _____

Serial # _____



***Read the manual thoroughly.
Improper installation, operation or
maintenance can cause property
damage, injury, or death.***

Part # KE004043-2 Rev F
February 2024

STATEMENT OF RESPONSIBILITIES / DÉCLARATION DES RESPONSABILITÉS / DECLARACIÓN DE RESPONSABILIDADES

This document is for use by experienced and trained Qualified Cleveland Range, LLC Authorized Service Representatives who are familiar with both the safety procedures, and equipment they service. Cleveland Range, LLC assumes no liability for any death, injury, equipment damage, or property damage resulting from use of, improper use of, or failure to use the information contained in this document. Cleveland Range, LLC has made every effort to provide accurate information in this document but cannot guarantee that this document does not contain unintentional errors and omissions.

The information in this document may be subject to technical and technological changes, revisions, or updates. Cleveland Range, LLC assumes no liability or responsibility regarding errata, changes, revisions, or updates.

Qualified Cleveland Range, LLC Authorized Service Representatives are obligated to follow industry standard safety procedures, including, but not limited to, OSHA regulations, and disconnect / lock out / tag out procedures for all utilities including steam, and disconnect / lock out / tag out procedures for gas, electric, and steam powered equipment and / or appliances.

All utilities (gas, electric, water and steam) should be turned OFF to the equipment and locked out of operation according to OSHA approved practices during any servicing of Cleveland Range equipment.

Qualified Cleveland Range, LLC Authorized Service Representatives are obligated to maintain up-to-date knowledge, skills, materials, and equipment.

Ce document est destiné à l'usage des Représentants de Service qualifiés et autorisés de Cleveland Range, LLC qui possèdent l'expérience et la formation ainsi que la bonne connaissance des mesures de sécurité et du matériel qu'ils entretiennent.

Cleveland Range, LLC décline toute responsabilité pour tout cas de décès, blessure, dommage matériel ou dommage aux biens résultant de l'utilisation, de la mauvaise utilisation ou du manquement d'utilisation des renseignements contenus dans ce document.

Cleveland Range, LLC s'est efforcé à fournir des renseignements précis dans ce document mais ne peut garantir que ce document soit exempt d'erreurs et d'omissions non intentionnelles.

Les renseignements contenus dans ce document peuvent être assujettis à des changements techniques et technologiques, des révisions ou des mises à jour.

Cleveland Range, LLC décline toute obligation ou responsabilité concernant les errata, modifications, révisions ou mises à jour.

Les Représentants de Service qualifiés et autorisés de Cleveland Range, LLC sont tenus de se conformer aux mesures de sécurité normalisées de l'industrie, y compris, mais sans s'y limiter, les réglementations de l'OSHA, les procédures de débranchement / verrouillage / étiquetage relatives à tous les services publics, dont l'approvisionnement en vapeur, et les procédures de débranchement / verrouillage / étiquetage relatives aux équipements et/ou appareils fonctionnant au gaz, à l'électricité et à la vapeur.

Au cours de tout entretien d'un appareil Cleveland Range, tous les services publics (gaz, électricité, eau et vapeur) doivent être FERMÉS au niveau de l'appareil et le dispositif de fonctionnement doit être verrouillé suivant les pratiques approuvées de l'OSHA.

Les Représentants de Service qualifiés et autorisés de Cleveland Range, LLC sont tenus d'actualiser en permanence leurs connaissances, compétences, matériel et équipement.

Este documento está destinado para el uso de los Representantes de Servicio calificados y autorizados de Cleveland Range, LLC quienes cuentan con la experiencia y la capacitación, así como el buen conocimiento de las medidas de seguridad y de los equipos que mantienen.

Cleveland Range, LLC, declina toda responsabilidad en caso de cualquier fallecimiento, lesiones, daños al equipo o daños a la propiedad resultantes de la utilización, del uso indebido o de la falta de utilización de la información provista en este documento.

Cleveland Range, LLC se ha esforzado en suministrar información precisa en este documento, pero no puede garantizar que este documento esté exento de errores y de omisiones no intencionales.

La información contenida en este documento podría estar sujeta a cambios técnicos o tecnológicos, revisiones o actualizaciones. Cleveland Range, LLC declina toda obligación o responsabilidad con respecto a erratas, modificaciones, revisiones o actualizaciones.

Los Representantes de Servicio calificados y autorizados de Cleveland Range, LLC tienen la obligación de seguir los procedimientos estándar de seguridad de la industria; los cuales incluyen pero no se limitan a los reglamentos de la OSHA (La Administración de la Seguridad y Salud Ocupacionales), los procedimientos de desconexión, cierre y etiquetado relativos a todos los servicios públicos incluyendo el suministro de vapor y los procedimientos de desconexión, cierre y etiquetado para los equipos y/o aparatos que funcionan a base de gas, electricidad o vapor.

Cuando se esté dando servicio o mantenimiento a un aparato de Cleveland Range, todos los servicios públicos (gas, electricidad, agua y vapor) deben estar APAGADOS para el equipo en cuestión y se debe seguir el procedimiento de cierre de operaciones de acuerdo con las prácticas aprobadas por la OSHA.

Los Representantes de Servicio calificados y autorizados de Cleveland Range, LLC tienen la obligación de actualizar constantemente sus conocimientos, destrezas, materiales y equipamiento.

**FOR YOUR SAFETY / POUR VOTRE SÉCURITÉ /
PARA SU SEGURIDAD**

FOR YOUR SAFETY

Do not store or use gasoline or any other flammable liquids and vapours in the vicinity of this or any other appliance.

WARNING: Improper installation, operation, adjustment, alteration, service, or maintenance can cause property damage, injury, or death. Read the installation and operating instructions thoroughly before installing, operating, or servicing this equipment.

Do not spray aerosols in the vicinity of this appliance while it is in operation.

This appliance is not to be used by persons with reduced physical, sensory, or mental capabilities, or lack of experience and knowledge, unless they have been given supervision or instruction concerning use of the appliance by a person responsible for their safety.

This appliance is not for use by children, and they must be supervised not to play with it.

Retain this manual for your reference.

POUR VOTRE SÉCURITÉ

Ne pas entreposer ou utiliser d'essence ou d'autres liquides ou vapeurs inflammables à proximité de cet appareil ou de tout autre appareil.

AVERTISSEMENT : Toute mauvaise pratique en matière d'installation, de fonctionnement, de réglage, de modification, d'entretien ou de maintenance peut causer des dommages matériels, des blessures ou la mort. Lisez la totalité des instructions d'installation et d'utilisation avant d'installer, d'utiliser ou d'entretenir cet équipement.

Ne pas pulvériser des aérosols dans le voisinage de cet appareil alors qu'il est en fonctionnement.

Cet appareil ne doit pas être utilisé par des personnes dont les capacités physiques, sensorielles ou mentales sont réduites, ou des personnes dénuées d'expérience ou de connaissance, sauf si elles ont pu bénéficier, par l'intermédiaire d'une personne responsable de leur sécurité, d'une surveillance ou d'instructions préalables concernant l'utilisation de l'appareil.

Conservez ce manuel pour votre référence.

PARA SU SEGURIDAD

No guarde ni use gasolina o cualesquiera otros líquidos o vapores inflamables en las cercanías de éste o cualquier otro aparato.

ADVERTENCIA: La indebida instalación, operación, ajuste, modificación, servicio o mantenimiento puede ocasionar daños a la propiedad, lesiones o muerte. Lea detenidamente las instrucciones de instalación y de operación antes de instalar, poner a funcionar o dar servicio a este equipo.

No pulverice aerosoles en las proximidades de este aparato mientras está en funcionamiento.

Este aparato no debe ser utilizado por personas con capacidades físicas, sensoriales o mentales reducidas, o que no tengan la experiencia y los conocimientos adecuados, a menos que estas personas hayan recibido supervisión e instrucciones en cuanto al uso del aparato por la persona responsable de la seguridad de ellas.

Guarde este manual para su referencia.

WARNING / AVERTISSEMENT / ADVERTENCIA



Inspect unit daily for proper operation. / Inspecter le bloc quotidiennement pour garantir le fonctionnement normal. / Inspeccione diariamente el funcionamiento correcto de la unidad.



Heavy. / Lourd. / Pesado.

Team or mechanical lift. / Levage en équipe ou mécanique. / Levantamiento en equipo o mecánico.



Surfaces may be extremely hot! Use protective equipment. / Les surfaces peuvent être extrêmement chaudes! Utiliser des équipements de protection. / ¡Las superficies pueden estar muy calientes! Utilice equipo protector.



Do not climb, sit, or stand on equipment. / Il ne faut pas monter, s'asseoir ni se tenir debout sur l'équipement. / No subirse, ni sentarse ni pararse sobre el equipo.



Do not remove guards or operate without them. / Ne pas supprimer les gardes ou fonctionner sans eux. / No retire los guardias ni funcionar sin ellos.



Keep hands away from moving parts and pinch points. / Tenir les mains à l'abri des pièces mobiles et des angles. / Mantenga las manos lejos de las piezas móviles y los puntos de presión.



Hot product and surfaces. / Produit et surfaces chaudes. / Producto y superficies calientes.



Keep clear of pressure discharge. / Se tenir hors de portée de la purge des soupapes de surpression. / Manténgase alejado de la descarga de presión.



Unit must be anchored as per manual. / Unité doit être ancrée selon les directives du manuel. / Unidad debe estar fijado según el manual.



Floor may become slippery from product spillage. / Déversement de produit peut causer de plancher à être glissant. / Derrame de producto puede causar piso a ser resbaladizo.



Have a qualified service technician maintain your equipment. / Demandez à un technicien en entretien et en réparation qualifié d'effectuer l'entretien de votre équipement. / Haga que un técnico de servicio calificado mantenga su equipo.



Shut off power at main fuse disconnect prior to servicing. / Couper l'alimentation sur le principal fusible sectionneur avant l'entretien. / Apague la alimentación eléctrica en el fusible desconector principal antes de darle servicio.



Ensure equipment is at room temperature and pressure gauge is showing zero or less prior to removing any fittings. / S'assurer que le chaudron se trouve dans une température ambiante et que le manomètre affiche zéro ou moins avant de déposer les raccords. / Asegúrese de que la marmita está a temperatura ambiente y el manómetro está mostrando cero o menos antes de quitar cualquier accesorio.



Appliance must not be supplied through an external switching device that is regularly switched on and off. / L'appareil ne doit pas être alimenté par un interrupteur externe régulièrement allumé et éteint. / El aparato no debe ser alimentado a través de un dispositivo de conmutación externo que se encienda y apague periódicamente.

**OPERATION, INSTALLATION & MAINTENANCE MANUAL GEMINI MODELS
24CGA6.2S, 24CGA10.2 & 24CGA10.2ES
Table of Contents**

CHAPTER 1 GENERAL INFORMATION	5
A. Laws, Codes, and Regulations.....	5
B. Operational Safety.....	5
C. Inspection for Shipping Damage.....	5
CHAPTER 2 PRODUCT INFORMATION	6
A. Model Numbers and Serial Numbers.....	6
B. Product Information Plate.....	6
CHAPTER 3 INSTALLATION PROCEDURE	7
A. Select a Location.....	7
B. Install Slide Racks.....	11
C. Install the Free Air Vented Drain Lines.....	11
D. Install Gas Supply Lines.....	12
E. Install Electric Power Lines.....	14
F. Water Supply Requirements and Installation.....	14
G. Generator Vent – Important.....	17
H. Installation Checklist.....	18
CHAPTER 4 COOKING WITH THE Gemini	19
A. Cooking Procedure.....	19
CHAPTER 5 EASY TIMER OPERATING INSTRUCTIONS	21
A. Main External Power Switch.....	22
B. Inspecting the Cooking Compartment.....	22
C. Power On (Automatic Fill).....	22
D. Lighting and Shutdown Instructions.....	24
E. Preheating the Steamer.....	24
CHAPTER 6 SHUTDOWN AND CLEANING PROCEDURES	25
A. Steam Generator Blowdown.....	25
B. Shut Down and Cleaning.....	25
CHAPTER 7 OPERATING TESTS AND FINAL CHECKOUT PROCEDURES	27
A. Burner Ignition Test (Lighting and Shutdown Instructions).....	27
B. Startup Test Procedure Gas Gemini.....	28
CHAPTER 8 PREVENTATIVE MAINTENANCE	31
A. Maintenance.....	31
CHAPTER 9 TROUBLESHOOTING GUIDE	34

CHAPTER 1 GENERAL INFORMATION

A. Laws, Codes, and Regulations

This equipment should be installed only by qualified, professional plumbers, pipe fitters, and electricians.

1. The installation of this appliance must conform with:
 - a) The National Fuel Gas Code, ANSI Z223.1 / NFPA 54 (latest edition), or the Natural Gas and Propane Installation Code CSA B1 49.1, as applicable.
 - b) The National Electrical Code, ANSI/NFPA 70 (latest edition), or the Canadian Electrical Code, CSA C22.2, as applicable.
 - When installed, the appliance must be electrically grounded in accordance with the above.
 - Note: This appliance is not GFI (GFCI) compatible.
 - c) The *Food Code* (latest edition) of the Food and Drug Administration (FDA).
2. This equipment is to be installed to comply with the applicable federal, state, or local plumbing codes.
3. Installation instructions must be read in their entirety before starting installation.
4. Install this appliance according to the policies and procedures outlined in this manual.
5. Installation must comply with **all** local fire and health codes.

DANGER

Improper installation, adjustment, alteration, service, or maintenance of this appliance, or installation of a damaged appliance can result in DEATH, INJURY, EQUIPMENT DAMAGE, and void the warranty.

NEVER install damaged appliances, equipment, or accessories.

ALWAYS have installation and service performed by qualified Cleveland Range authorized personnel.

B. Operational Safety

The Operational Safety section outlines minimum safety policies and procedures for operating one or more Cleveland Range appliances.

1. Do not store anything on top and underneath the appliance.
2. KEEP THE APPLIANCE AREA FREE AND CLEAR OF COMBUSTIBLES.
3. Proper air supply for ventilation is REQUIRED for and CRITICAL to safe, efficient operation of this appliance.
4. Place non-slip draining anti-fatigue mats rated for use in wet, greasy, or dry work areas on the floor in front of the appliance and other locations as needed. Obtain the best mats for your needs from your local supplier.
5. Wear BOOTS appropriate to the work area to help protect feet, and to help prevent slips and falls.
6. Allow only qualified Cleveland Range authorized service representatives to service the appliance.
7. Use only factory authorized repair parts.
8. Maintain written records of appliance service, maintenance, and repair. See Chapter 6.

DANGER

Operating this appliance out of level can cause DEATH, INJURY, and EQUIPMENT DAMAGE.

This appliance must be level both front-to-back and side-to-side in all installations.

NEVER operate this appliance out of level.

If this appliance is suspected to be out of level, shut it down at once and call your qualified Cleveland Range authorized service agency immediately.

C. Inspection for Shipping Damage

If the appliance is damaged or damage is suspected:

1. Submit a Damage Claim to the shipper and inform your dealer immediately.
2. Inform Cleveland Range in writing within three (3) days.

CHAPTER 2 PRODUCT INFORMATION

A. Model Numbers and Serial Numbers

1. Cleveland Range, LLC assigns two product identification numbers to each appliance: a model number and a serial number.
2. Please provide the model number and serial number when you contact Cleveland Range or a qualified Cleveland Range authorized service representative.

- Model Number _____

(Write the Model Number of your appliance here)

- Serial Number _____

(Write the Serial Number of your appliance here)

3. This manual covers the Gemini Model No. 24CGA6.2S, 24CGA10.2, and STEAMSAVER™ 24CGA10.2ES Dual Steam Generator and Convection Steamer. Each character of this model number identifies a characteristic of the steamer.

The Gemini Model No. STEAMSAVER™ 24CGA10.2ES is 24 inches wide, a Convection steamer, Gas powered, and an Atmospheric steam generator with a capacity for 10 cooking pans, this model has the extra suffix “.2” to differentiate it from our standard 10 pan model that does not have two separate generators and Energy Saver for models designed for high efficiency operation. This manual covers all standard features and options available on Gemini gas steamers.

Model 24CGA6.2S and 24CGA10.2 are steamers designed for high-capacity operation. The burners that supply steam and the condenser spray to the compartments are on continuously while the unit is in timed cooking mode or in the manual cooking mode. The burners and condenser spray stay on until the cooking operation is complete.

Model STEAMSAVER™ 24CGA10.2ES are steamers designed for high efficiency operation. These models incorporate the exclusive energy and water saving design of the STEAMSAVER™ Technology (SST). The energy saver models provide steam in a similar manner to our high-capacity models except that the flow of steam is regulated by cycling the burners off once the desired cooking temperatures is reached. When the temperature drops to a set point below the desired cooking temperature the burners will turn back on to bring the cooking compartment back up to temperature. The burners will continue to cycle on and off as necessary to maintain temperature until the cooking operation is complete. The condenser spray is activated periodically to cool the condensate water to the drain automatically using a thermostat control.

NOTE TO INSTALLER: There are some significant differences in the installation procedures between the 24CGA6.2S, 24CCG10.2, and STEAMSAVER™ 24CGA10.2ES units. Pay close attention to section headings for specific installation instructions for each model listed.

B. Product Information Plate

The Product Information Plate is on the side opposite the control panel. It lists the:

- Model
- Serial number
- Gas
- Electric
- Wiring requirements

CHAPTER 3 INSTALLATION PROCEDURE

DANGER

Operating this appliance out of level can cause DEATH, INJURY, and EQUIPMENT DAMAGE. This appliance must be level both front-to-back and side-to-side in all installations.

NEVER operate this appliance out of level.

If this appliance is suspected to be out of level, shut it down at once and call your qualified Cleveland Range authorized service agency immediately.

A. Select a Location

For safe and efficient operation:

1. Installation must comply with all local fire and health codes.
2. The location selected must be capable of supporting this appliance.
 - The operating weight of a Gemini is 650 pounds.
3. Position the appliance so it will not tip or slide.
4. The operating surface must be level enough to allow leveling with the adjustable legs. This appliance **MUST** be level both front to back and side to side before operation.
5. A suitable drain must be available within 12 feet of this appliance. Do NOT install the appliance directly over a drain.
6. The location must include space for Operating and Service/Secondary Clearances and the Exhaust Hood. See Figures 3-1, 3-2, and 3-3.

WARNING

All clearance requirements above, below, and around this appliance are the same for non-combustible locations as for combustible locations.

Failure to maintain required clearances and additional distances as needed can result in INJURY and EQUIPMENT DAMAGE.

Consult manufacturers' literature, and sales and service agencies as needed.

7. KEEP THE APPLIANCE AREA FREE AND CLEAR OF COMBUSTIBLES.
8. Proper air supply for ventilation is REQUIRED for and CRITICAL to safe, efficient operation of this appliance.
9. Make sure the air vents of this appliance are not blocked with or by anything.
10. Allow for sufficient extra distance if a "high heat source," e.g., a broiler, is located next to this appliance. Contact Cleveland Range for recommendations.
11. Do NOT install this appliance directly over a drain. Steam rising up out of the drain will adversely affect operation, hamper cooling air circulation, and damage electrical and electronic components.

Clearance Requirements

Figures 3-1, 3-2, and 3-3 illustrate the dimensions and clearances required for these steamers. Maintain the following minimum dimensions around the unit for safe and efficient operation, maintenance, and service.

- Maintain a 3-inch operating clearance at the sides of the unit, and at least a 3-inch clearance at the back.
- A 12 in clearance is recommended on the right side for servicing the steamer.
- Approximately 24 inches of clearance is recommended in front of the unit for opening the door and standard pan clearance.

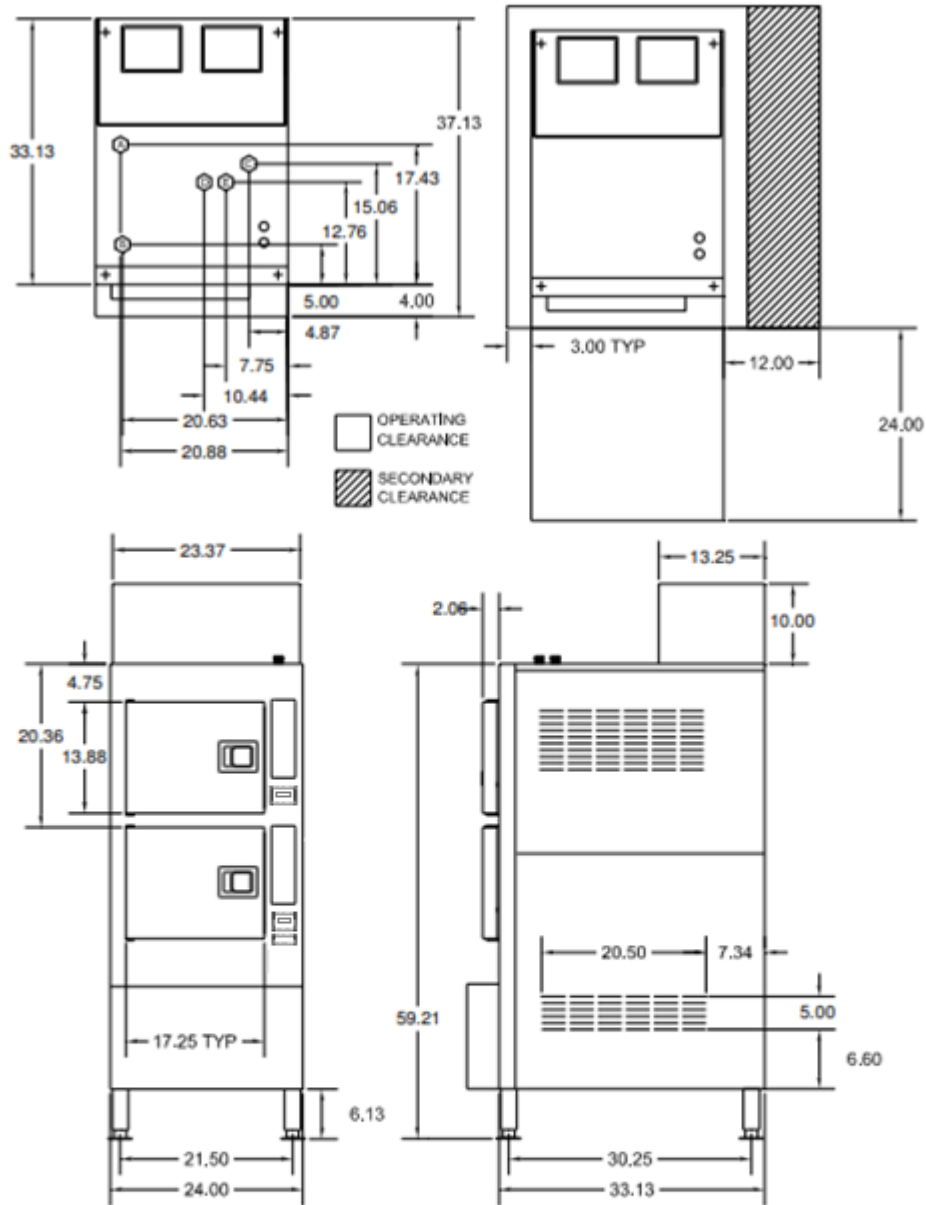

A A GAS			B ELECTRIC	COLD WATER	CLEARANCE	C DRAINAGE
1-1/4" IPS line size, 3/4" connection			115V-1Phase, 60 Hz.	35 PSI minimum	RIGHT = 12.00" for service	1-1/2" dia. NPT
NATURAL	PROPANE	BTU	2 Fans & controls	60 psi maximum	SIDES = 3.00"	Do not connect other units to this drain.
Piping 3/4" NPT	Piping 3/4" NPT.	50,000 each	150 watts each	(1) 3/8" dia. IPS for D Condenser	REAR = 3.00"	
Supply pressure	Supply pressure	Generator		(1) 3/8" dia. IPS for E Generator	FRONT = 24.00"	Drain must be free air vented.
4.50" W.C. Min. 14.00" W.C. Max.	11.00" W.C. Min. 14.00" W.C. Max.	100,000 total				Do not use PVC pipe.
Manufacturer must be notified if unit will be used above 2,000 feet						The drain must not be located beneath the steamer itself.

Figure 3-1 Gemini 24CGA6.2S Dimensions and Clearances

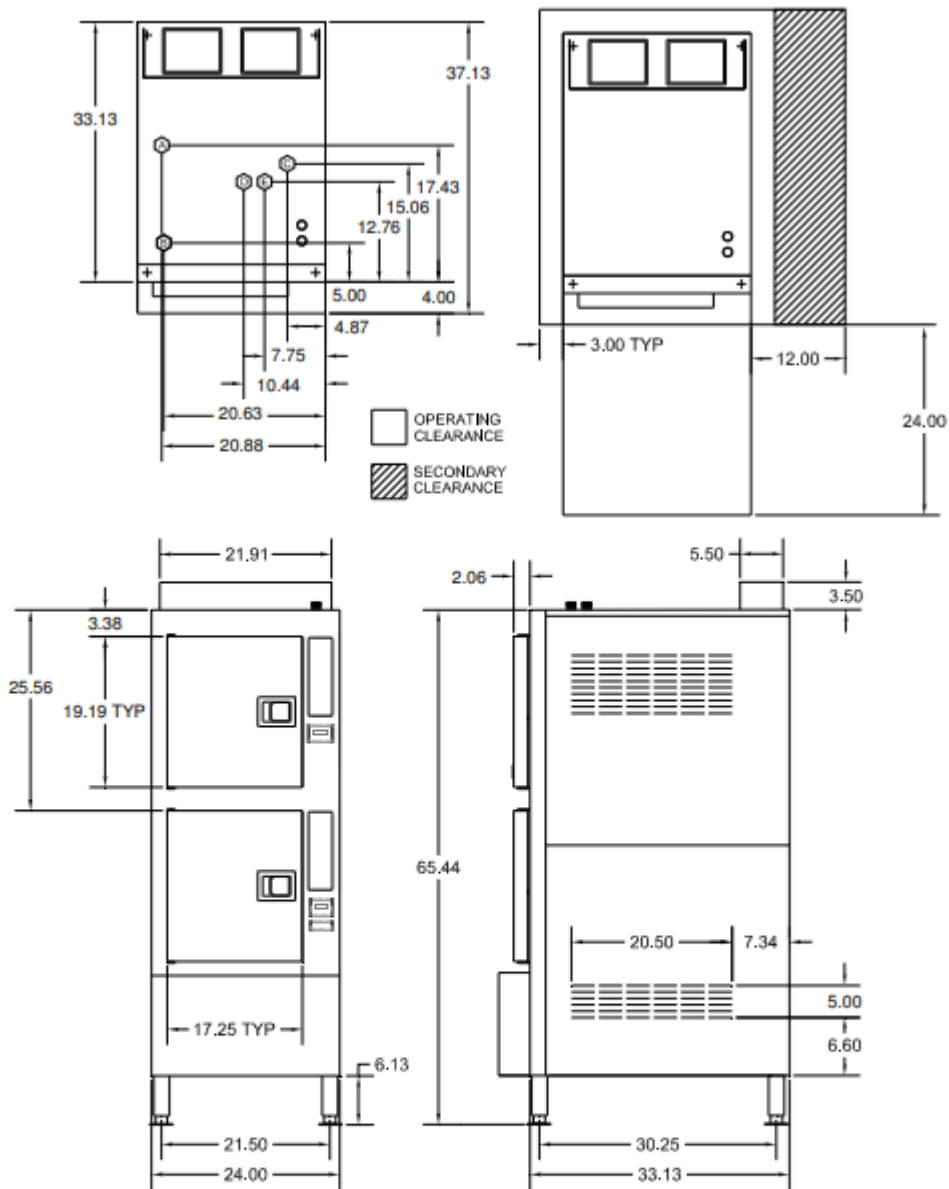

A GAS			B ELECTRIC	COLD WATER	CLEARANCE	C DRAINAGE
1-1/4" IPS line size, 3/4" connection			115V-1Phase, 60 Hz.	35 PSI minimum	RIGHT = 12.00" for service	1-1/2" dia. NPT
NATURAL	PROPANE	BTU	2 Fans & controls	60 psi maximum	SIDES = 3.00"	Do not connect other units to this drain. Drain must be free air vented.
Piping 3/4" NPT	Piping 3/4" NPT.	72,000 each	150 watts each	(1) 3/8" dia. IPS for D Condenser	REAR = 3.00"	
Supply pressure	Supply pressure	Generator		(1) 3/8" dia. IPS for E Generator	FRONT = 24.00"	Do not use PVC pipe The drain must not be located beneath the steamer itself.
4.50" W.C. Min. 14.00" W.C. Max.	11.00" W.C. Min. 14.00" W.C. Max.	144,000 total				
Manufacturer must be notified if unit will be used above 2,000 feet						

Figure 3-2 Gemini 24CGA10.2 Dimensions and Clearances

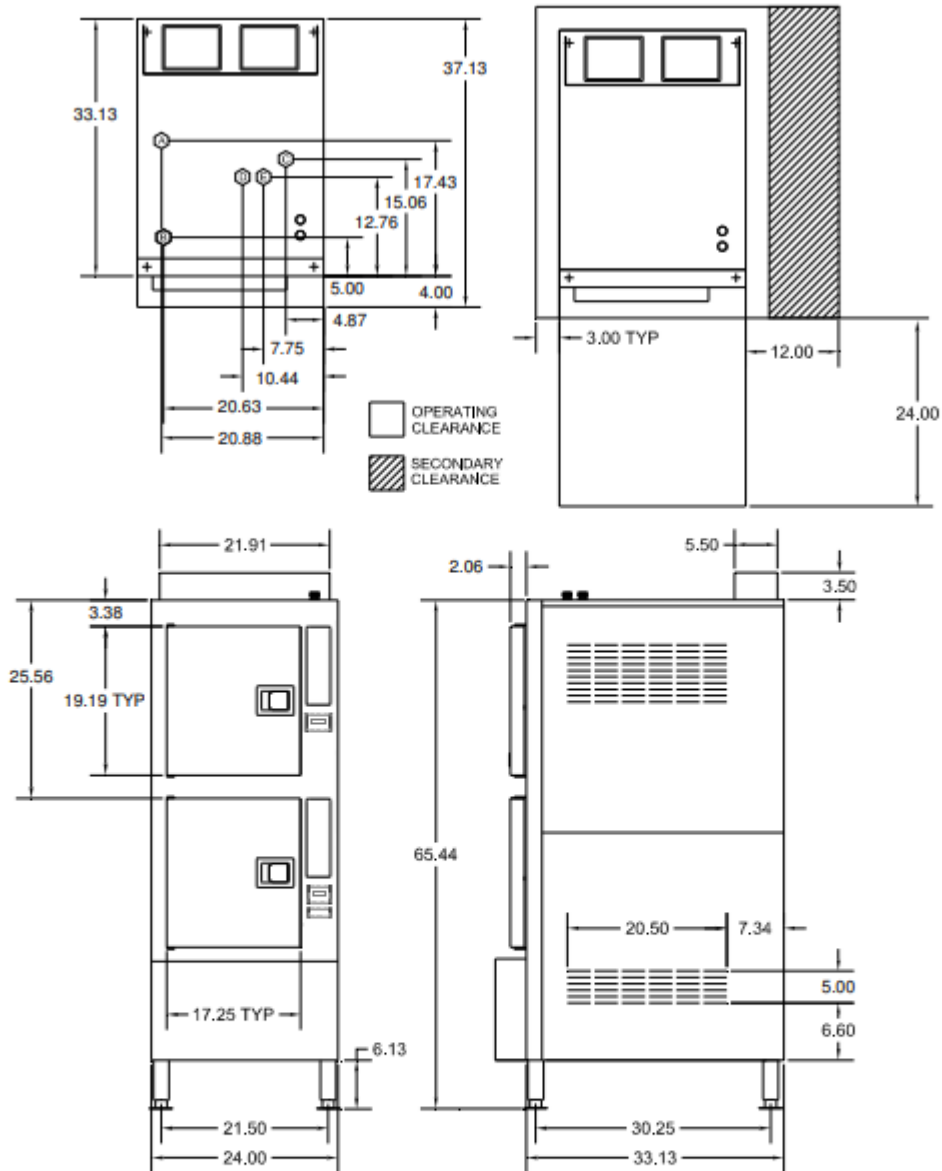

A GAS			B ELECTRIC	COLD WATER	CLEARANCE	C DRAINAGE
1-1/4" IPS line size, 3/4" connection			115V-1Phase, 60 Hz.	35 PSI minimum	RIGHT = 12.00" for service	2" dia. OD
NATURAL	PROPANE	BTU	2 Fans & controls	60 psi maximum	SIDES = 3.00"	Do not connect other units to this drain. Drain must be free air vented.
Piping 3/4" NPT	Piping 3/4" NPT.	50,000 each	150 watts each	(1) 1/2" dia. IPS for D Condenser	REAR = 3.00"	
Supply pressure	Supply pressure	Generator		(1) 3/8" dia. IPS for E Generator	FRONT = 24.00"	Drain plumbing must be able to withstand 140°F (60°C).
4.50" W.C. Min. 14.00" W.C. Max.	11.00" W.C. Min. 14.00" W.C. Max.	100,000 total				The drain must not be located beneath the steamer itself.
Manufacturer must be notified if unit will be used above 2,000 feet						

Figure 3-3 Gemini STEAMSAVER™ 24CGA10.2ES Dimensions and Clearances

Exhaust Hood Requirements

The Gemini gas steamer MUST be installed under a suitable ventilation hood as required by the National Fuel Gas Code, ANSI Z223.1/NFPA 54. The venting hood system must also include an interlock to prevent the operation of this steamer without the operation of the ventilation hood.

The exhaust hood must extend over the gas flue opening on top of the steamer and meet the following requirements:

1. The Gemini gas steamer must be vented in accordance with all local, state and national codes for venting gas fired appliances.
2. The exhaust hood must be sized for the cumulative ventilation requirements of all the gas-fired appliances in the area including the Gemini. Figures 3-1, 3-2, and 3-3 contain the dimensions, gas flow, and BTU per hour data required to calculate the minimum required hood dimensions and minimum ventilation capacity (c.f.m.) for the Gemini 6 and 10 pan steamers.
3. Do not connect the exhaust hood directly to the flue outlet of the steamer.
4. If an existing hood cannot be used, a new one should be constructed over the steamer.

Positioning and Leveling the Steamer

NOTE: If there is not enough room to work on the drain, electrical, gas and water lines with the unit in place, postpone positioning and leveling of the unit until all site preparation is completed. After the lines are prepared, position and level the steamer then connect the utility lines.

⚠ WARNING

INJURY and EQUIPMENT DAMAGE could result from improper lifting. A Gemini Steamer weighs approximately 545 pounds. Use enough workers with experience lifting heavy equipment to place the steamer on the supporting surface

- Move the steamer into position. Using a level, adjust the adjustable legs until the unit is level.

B. Install Slide Racks

1. Refer to Figure 3-4. Each rack has four loops: two at the top and two at the bottom. Hold the slide rack so the ends of the hanger loops are towards the cavity wall, as shown in the figure.
2. Slide one rack into the compartment with loops toward one side.
3. Hook the loops over the top and bottom pins.
4. Repeat steps 1 through 3 for the other racks.

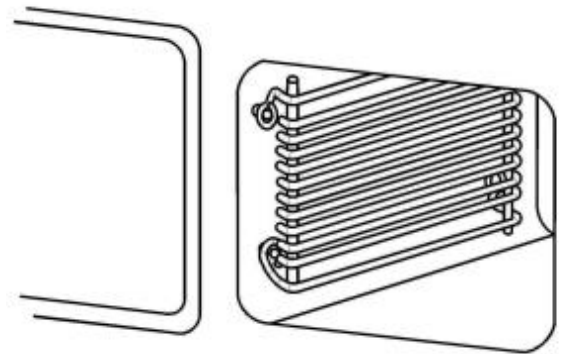

Figure 3-4 Slide Rack Installation

C. Install the Free Air Vented Drain Lines

NOTE: There are significant differences in the installation procedures between the 24CGA6.2S, 24CCG10.2 and the STEAMSAVER™ 24CGA10.2ES units.

Pay close attention to section headings for specific installation instructions on each model listed.

a. Drain Installation for Models 24CGA6.2 & 24CGA10.2 (high capacity) Only

Furnishing and installing the drain line is the responsibility of the owner and/or installer. Figure 3-5 illustrates a drain layout recommended by Cleveland Range.

⚠ WARNING

DEATH, INJURY, AND EQUIPMENT DAMAGE could result from improper installation of the drain outlet lines.

Improper installation of these lines could void the Gemini Steamers warranty. The following restrictions are critical to the safety of personnel and equipment and must not be violated under any circumstances.

Do not connect the drain line into PVC or any drain material that cannot sustain 180°F.

Do not connect drains from any other equipment to the drain line of the Gemini Steamer.

Do not connect the drain outlet extension line directly to a floor drain or sewer line.

The drain line must be free air vented, have gravity flow from the steamer, and terminate outside the perimeter of the unit.

1. The drain lines must be installed in compliance with the Food Service Sanitation Manual of the Food and Drug Administration (FDA) and WITH THE applicable Federal State, or Local plumbing codes.
2. Do not install the steamer directly over a drain. Steam rising up out of the drain will adversely affect operation, cooling air ventilation and may damage electrical components.
3. The total length of pipe and number of bend fittings required to reach the open drain determines the pipe size used to extend the drain line to an open drain.
 - If the drain outlet extension requires 6 feet or less of pipe, and no more than two elbows are required, 1- ½ inch ID pipe and fittings are acceptable.
 - If the drain outlet extension requires 6 to 12 feet of pipe, or requires three or more elbows, 2-inch ID pipe and fittings are required.
4. The drain line must have a gravity flow from the steamer drain outlet to the floor drain. Do not install a trap in the drain line.
5. Free air venting requires a minimum of 1 inch of clearance between the end of the drain line and the top of the floor drain.
6. Do not connect the steamer drain directly to drains or plumbing of any other equipment.
7. Connect the drain to the steamer as described below:
 - The steamer is supplied with a 1-½ -inch pipe connection at the bottom of the unit (Figure 3-5).
 - When assembling the pipes and fittings of the drain outlet extension, apply a hardening type pipe sealant to the threads, and thread them together FINGER TIGHT ONLY. DO NOT USE A WRENCH.

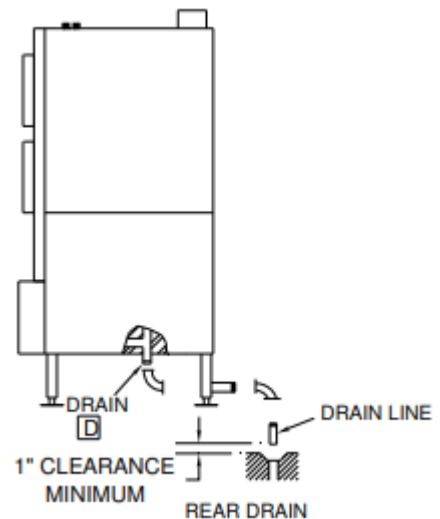

Figure 3-5

Typical Drain Connection

D. Install Gas Supply Lines

1. Gas Supply Requirements

- a) Make sure the gas supply type matches the type of gas shown on the rating plate.
- b) Make sure that the gas supply pressure does not exceed 14" water column, and falls within the acceptable gas pressure range shown below:
 - Natural gas pressure must be between 4½" – 14" water column.
 - Propane gas pressure must be between 11" – 14" water column.

2. Install Gas Supply Lines

The installer/owner is responsible for furnishing and installing the gas supply lines, valves, regulators, and accessories. When installing the gas supply lines and accessories, observe the following:

- a) The installation must conform with local codes, or in the absence of local codes, with the National Fuel Gas Code, ANSI Z223.1 (latest edition) or the Natural Gas Installation Code, CAN/CGA-B149.1 or the Propane Installation Code, CAN/CGA-B149.2 as applicable.
- b) THE GAS SUPPLY PRESSURE TO THE STEAMER MUST NEVER EXCEED 14" WATER COLUMN ($\frac{1}{2}$ psi). If the gas supply pressure exceeds 14" water column; a pressure regulator must be installed in the gas supply plumbing to reduce the pressure to the steamer.
- c) Refer to Figure 3-6 for the recommended layout of the gas supply lines. Refer to Figures 3-1, 3-2, or 3-3 depending on which model you have, Detail A for the location of the $\frac{3}{4}$ inch gas inlet of the steamer.
- d) Install a manual shut off valve between the gas supply and the steamer. See Figure 3-6. From now on this valve will be referred to as the Main Manual gas valve.
- e) It is recommended that a sediment trap (drip leg) be installed in the gas supply line. See Figure 3-6.
- f) Use a pipe sealant compound, which is resistant to LP gas.

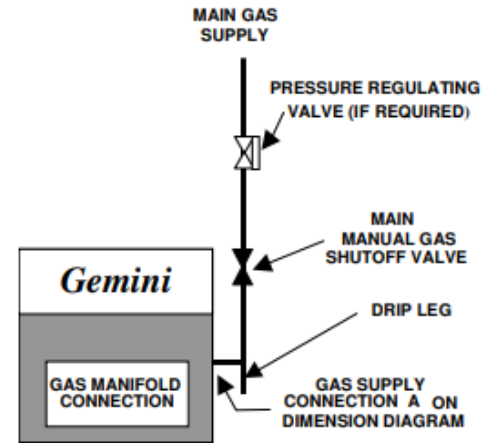

Figure 3-6, Recommended Gas Supply Line Layout

3. Testing Gas Supply Lines

⚠ WARNING

FIRE OR EXPLOSION HAZARD

LEAKING GAS CAN CAUSE FIRE OR EXPLOSION WITH PROPERTY DAMAGE, INJURY OR LOSS OF LIFE.

If the installer smells gas, or suspects there is a gas leak, immediately refer to the posted gas leak instructions. The posted instructions are provided by the local gas supplier and supersede any other instructions. Until the leak is stopped observe the following precautions in addition to the posted instructions:

- Do not light or start any appliance.
- Do not touch any electrical switch.
- Do not use any phone in the building.
- Immediately call the gas supplier from a phone away from the building.
- Follow the gas supplier's instructions.
- If the gas supplier cannot be reached call the fire department.

a) Leak Testing the Appliance

Before permanently turning on gas to the steamer or after any service to the gas supply, test all pipe joints for leaks with a soap and water solution. All leaks must be corrected before attempting to operate the steamer.

b) Pressure Testing the Gas Supply Lines

The steamer must be isolated from the gas supply system during any pressure testing as follows:

- The appliance and its main manual shut-off valve must be disconnected from the gas supply piping system during any pressure testing of the system at test pressures in excess of 14" water column ($\frac{1}{2}$

psi or 3.45 kPa). Be sure to leak test all fittings with a soap and water solution after reconnecting the gas supply.

- The appliance must be isolated from the gas supply piping system by closing its main manual shut-off valve during any pressure testing of the gas supply piping system at test pressures equal to or less than 14" water column (½ psi or 3.45 kPa).

E. Install Electric Power Lines

The electrical supply must match the power requirements specified on the steamers rating plate and be made in accordance with the following requirements.

1. The steamer must be grounded and have the electrical power lines installed in accordance with local codes and/or the National Electric Code, ANSI/NFPA No. 70-LATEST EDITION (USA) or the Canadian Electrical Code, CSA C22.2, as applicable. The wiring diagram is located on the back of the lower front panel.
2. Power connection
 - This unit is not suitable for connection to a GFCI (Ground fault Circuit Interrupter).
 - Cleveland Range recommends that the unit be connected to the electrical system, using a flexible conduit system compliant with the applicable codes.
3. A main disconnect switch and a separate fuse or breaker should be installed near the unit as shown in Figure 3-6. See Figures 3-1, 3-2, or 3-3 for the steamers power requirements. Throughout the remainder of this manual the fused disconnect switch is referred to as the main external power switch.
4. Refer to the connection diagrams in Figure 3-8 and connect the wires to the terminal block and ground connector accordingly.

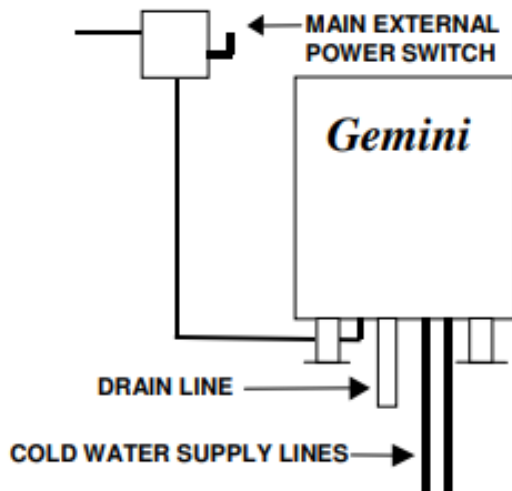

Figure 3-7

Recommended Electrical Layout

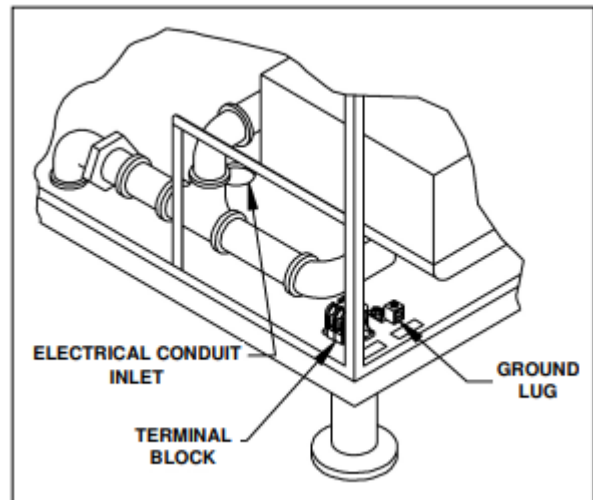

Figure 3-8

Electrical Connections

F. Water Supply Requirements and Installation

1. Water Supply Requirements

⚠ CAUTION

Using water not within the limits specified in this manual could void or reduce Cleveland Range's warranty coverage of the steamer.

a) Water Quality

As with any steam generating equipment, poor water quality degrades the performance of the steamer.

Check the quality of supply water as described below before starting construction of the water supply lines. If a water treatment system must be installed to achieve acceptable water quality, install it before connecting the water supply lines to the Gemini Steamer.

If softened or chlorinated water is used in a Gemini steam generator, a carbon type filter must be used for the water before it enters the steamer to remove Chlorine or other salts. If the water supply is treated or softened either by the Water Company or on the premises, it may contain chlorine or various salts. These additives are damaging to the steam generator. Salts and chlorine used to soften or treat water cause rapid scale buildup, and/or increased corrosion if allowed to flow into the steamer.

Contact a local water treatment specialist for an on-the-premises water analysis. The recommended minimum feed water quality requirements for the steamer are listed in Table 3-1.

Table 3-1. Minimum Water Quality Requirements

Scale Forming Factors

Total Dissolved Solids	less than 60 parts per million
Silica	less than 13 parts per million
Alkalinity	less than 20 parts per million

Corrosion-Causing Factors:

Free Chlorine	less than 0.5 parts per million
Chloride	less than 30 parts per million
PH factor	greater than 7.5

b) Water Supply System

Provide a water supply system that fulfills the requirements of the limits listed in Table 3-1. The supply must provide a minimum dynamic pressure of 35 psi (2.4 kg/cm²) and a maximum static pressure of 60 psi (4.1 kg/cm²).

- If analysis shows that the supply water is NOT within the required limits, either a water treatment system and/or carbon filter must be installed in the line feeding the steam generator or the frequency of maintenance, cleaning, and descaling must be increased beyond that recommended in the maintenance schedule (Chapter 8).

2. Install Water Supply Lines

The installer/owner is responsible for the correct water connection of the unit. When connecting the water supply lines observe the following instructions and all national and local codes and regulations:

- a) Never connect the unit to HOT WATER. The condenser system of the steamer will not work properly if it is connected to HOT or WARM water.
- b) The water supply should have a minimum flow pressure of 35-psi (2.4 kg/cm²) and a maximum static pressure of 60-psi (4.1 kg/cm²). If the static pressure is above 60 psi, a pressure regulator must be used set at approximately 50 psi. Pressure above 60 psi can damage the solenoid valves.
- c) The Gemini Steamers are supplied with two connection points for incoming water, one feeds the condensers and the second supplies feed water to the generators. If the local water supply is of poor quality, it is recommended that treated or otherwise filtered or conditioned water be used to supply the feed water to the generators. In the case of using a separate water supply, use the layout shown in Figure 3-10.
- d) Pay attention to the following requirements and recommendations when connecting the steamer to the water supply:

- i. Cleveland Range recommends the plumbing layout illustrated in either Figure 3-9, for installations using a single water supply or Figure 3-10 if a separate conditioned water supply is being used for boiler feed. Note: If using a single water feed to the system the supply piping to the tee fitting should be of at least the next largest size of pipe to the connection provided at the steamer.
- ii. The steamer has IPS fittings for the water connections to the generator and to the condenser. These fittings are detailed as D and E in Figures 3-1, 3-2, or 3-3 depending on model.
- iii. Install a manual water valve between the main cold water supply line(s) and the steamer supply lines.
- iv. This steamer must be installed with adequate backflow prevention in all supply lines, to comply with federal, state or local codes having jurisdiction.
- v. The water supply line(s) should be designed so that the unit can be moved for service.

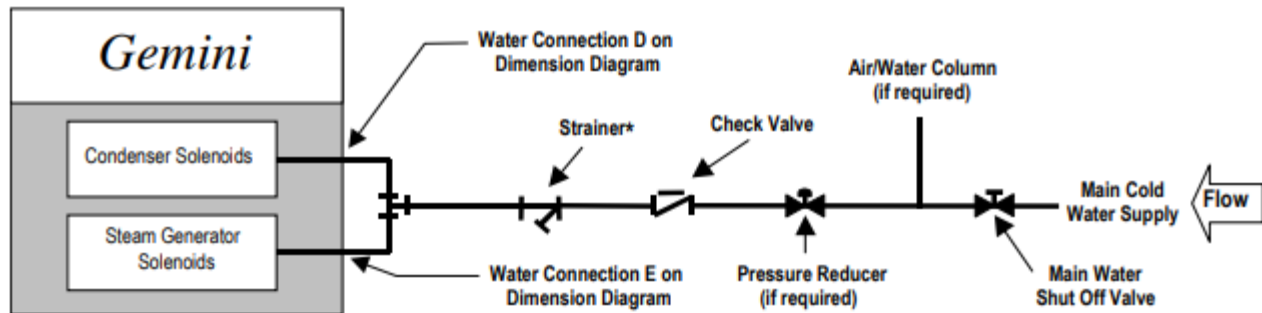

Figure 3-9 Cleveland Range Single Water Supply Arrangement
 [*Installed internal on all Gemini Models]

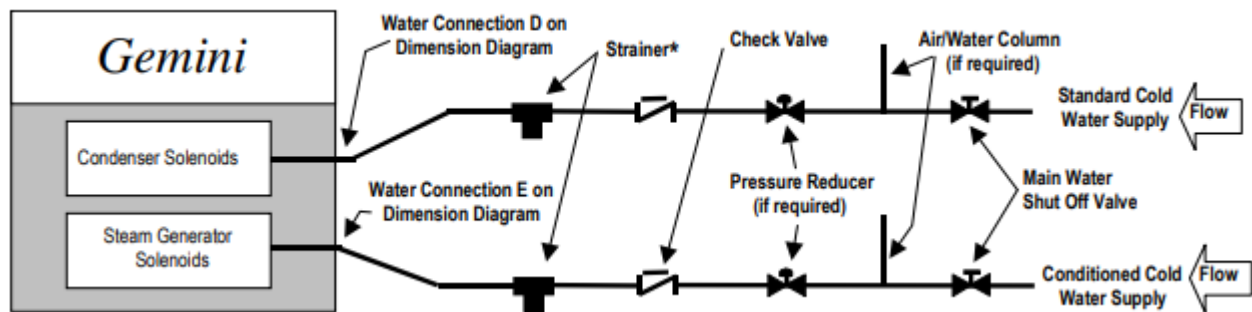

Figure 3-10 Cleveland Range Single Water Supply Arrangement when Using Separate Conditioned Feed Water Supply
 [*Installed internal on all Gemini Models]

- vi. A 40 or 50-mesh water strainer (dirt filter) of one of the types and construction illustrated in Figure 3-11, Cleveland Range part number 106684 or 19870 is supplied with the unit and should be installed where indicated in the plumbing layout.

NOTE: On some Models the strainer has already been installed as part of the internal water piping.

- Make sure the arrow on the strainer body points in the direction of flow into the steamer.
- Install the strainer so the access nut points down.

- vii. Construct all supply lines up to the point of installing the strainer. Flush the water supply lines before connecting the strainer.
- viii. Apply pipe dope or Teflon tape to any threaded connection.

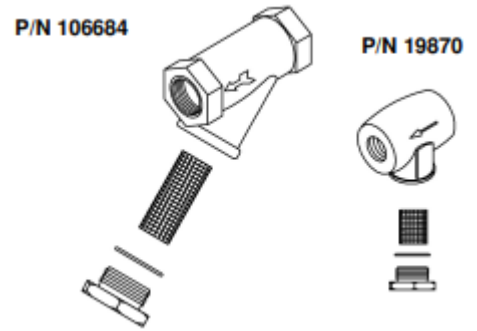

Figure 3-11, Water Strainer Assembly

3. Testing Water Supply Lines

- a. Check all connections for proper tightness. Remove the side panel to inspect water connections inside the steamer.
- b. Open the water supply valves.
- c. Check all lines and connections for leakage, both inside and outside the steamer.
- d. If Startup and Checkout will be performed next, leave the right side panel off; otherwise, replace the side panel and secure it to the unit.

G. Generator Vent – Important

IMPORTANT

When installing this steamer, under no circumstances should the Steam Vent be removed, capped or attached to piping of any kind.

This fitting is an auxiliary safety intended to prevent any pressure from building up in the generator in the unlikely event the steam outlets of the steamer should become plugged or restricted.

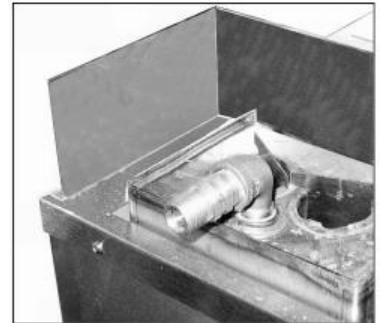

Figure 3-12 Generator Vent

H. Installation Checklist

Installation Check List

TASK		REFERENCE	COMPLETED
Preparation	Verify Electric Power Requirements	Chapter 3 Section E	
	Verify Gas Supply Requirements	Chapter 3 Section D	
	Verify Exhaust Hood Requirements	Chapter 3 Section A	
	Test Supply Water Quality	Chapter 3 Section F	
	Check Operating Location Clearances	Chapter 3 Section A	
Installation	Verify Steamer is Level	Chapter 3 Section A	
	Check Drain Line Connection	Chapter 3 Section C	
	Check Exhaust Hood	Chapter 3 Section A	
	Check Electrical Line Connection	Chapter 3 Section E	
	Check Water Supply Connection	Chapter 3 Section F	
	Test Water Supply Lines	Chapter 3 Section F	
	Check Gas Supply Connection	Chapter 3 Section D	
	Leak Test Gas Supply Connection	Chapter 3 Section D	
	Check Burner Ignition Test	Chapter 7 Section A	
	Perform Startup and Checkout	Chapter 7 Section B	

CHAPTER 4 COOKING WITH THE Gemini

DANGER

Do NOT breathe steam, hot air or condensate. DEATH or INJURY will result.

WARNING

Hot air, steam, and condensate will cause burns and scalds.

To help prevent burns and scalds when opening steamer doors: always stand to the hinge side and back from the doors, slowly open the door, and wait for the steam and heat to dissipate before reaching into the steamer.

The Gemini Steamer is a continuously operating appliance, so parts are ALWAYS HOT when the Main External Power Switch or the ON/OFF Switch is in the ON position.

When the ON/OFF Switch is turned to the OFF position, the Gemini will remain HOT for some time. Contact with hot surfaces and steam can cause burns and scalds. Avoid contact with hot surfaces and steam.

If the steamer door is stuck shut: DO NOT force the door open.

The door stuck shut may indicate a blocked drain. Hot water can fill the cooking compartment and spill out if the door is forced open causing injury and equipment damage.

If the Gemini door is stuck shut:

- Turn OFF the steamer.
- Call a qualified Cleveland Range authorized service technician.
- Wait for the steamer to cool before servicing.

CAUTION

Some food drip juices. Use a solid catch pan under perforated pans when cooking food that drips juices. Dripping juices can cause burns and clog the drain.

Do NOT use oven racks that are bent or damaged in any way.

DO insert pans and accessories LEVEL and INSIDE the oven racks.

Pans and accessories placed in damaged or out of level racks, or outside racks can tip and spill, causing burns, injuries and/or equipment damage.

A. Cooking Procedure

1. Before Cooking
 - a. Inspect and clean the drain and cooking compartment as required.
 - b. If necessary, preheat the cooking compartment.
 - c. Slide the pans of food into the slide racks inside the steamer. Do not place pans or anything else on the bottom of the compartment.
 - For the best cooking results, use shallow, 2-1/2-inch-deep, perforated pans without covers. These give the best heat transfer and shortest cooking time.
 - d. Close the steamer door.
2. Refer to **Easy Timer Operating Instructions** in Chapter 5 to start cooking.
 - While cooking, occasionally check the water in the reservoir for food particles and oils. If the water is dirty or cloudy, change the water. See Chapter 8.

- The steamer compartment of the Gemini Steamer is equipped with an **automatic door interlock switch** that turns off the heating elements and condenser when the door to the compartment is opened.

WARNING

Burn and Scald Hazard

Even though the heat shuts off as soon as the door is opened, it may take up to a minute for production of steam to end and residual steam in the system to clear from the cooking compartment.

To help avoid injury, always wait until the residual steam clears before reaching into the cooking compartment, and always wear dry heatproof gloves when reaching into the cooking compartment. Wet or damp gloves conduct heat and can cause burns when touching hot items.

3. After Cooking

- Carefully open the cooking compartment door and remove the pans from slide racks.
- If the steamer will be used again in a few minutes, shut the door to maintain the cooking compartment temperature.
- If another use is not planned for more than half an hour, leave the cooking compartment door slightly open to reduce internal pressure while the steam condenses and the compartment cools.
- If the steamer is not being used again during this shift, perform the Power OFF and Shut Down and Cleaning Procedures, found in Chapter 6.

CHAPTER 5 EASY TIMER OPERATING INSTRUCTIONS



DIGITAL DISPLAY

CONTROL KNOB

Enabled with **TIMED** mode

TIMER START/STOP BUTTON in **TIMED** mode

TIMED/MANUAL SWITCH BUTTON
(Press for 5 sec)



ON-OFF SWITCH

⚠ CAUTION

Press switch and button with fingertips only.

INJURY and EQUIPMENT DAMAGE can result from pressing switches and buttons with anything else.

A. Main External Power Switch

Usually, the steamers main external power switch is left ON. If the main external power switch was left in the OFF position, turn it ON as follows.

1. Check that the water supply valves are open.
2. Turn the ON/OFF switch to the OFF position.
3. The control panel settings are not important in this procedure. The control panel circuits are not powered while the ON/OFF switch is set to OFF.
4. Refer to the main external power switch in Figure 5-1 and turn on electric power to the steamer. The steam generators will immediately start blowdown cycles. The blowdown cycle lasts 3 minutes (Find Chapter 6 “Shutdown and Cleaning Procedure” for blowdown cycle).

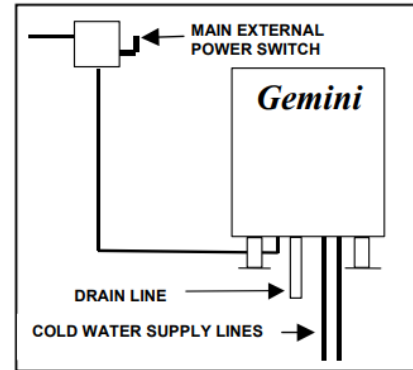

Figure 5-1 Main External Power Switch

B. Inspecting the Cooking Compartment

At the back of the cooking compartment, a drain screen covers the drain (Refer to Figure 5-2). The screen prevents large food particles from entering and blocking the drain line. Any blockage of the drain line or screen can reduce drainage from the cooking compartment resulting in reduced cooking performance, equipment damage, and a hazard to the operator. A blocked or slow drain may cause:

- Hot water to collect in the compartment and spill out when the compartment door opens.
- Pressure fluctuations in the compartment, resulting in steam leaks around the door gasket, or compartment implosion.
- Reduced convection in the compartment, reducing cooking performance.

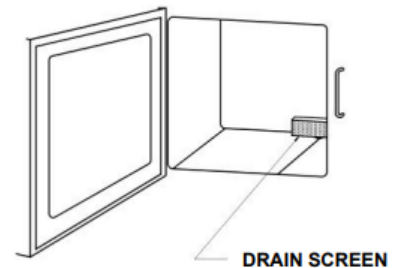

Figure 5-2
Compartment Drain Screen

⚠ CAUTION

Steam leaks around the door, cooking compartment flooding, reduced cooking performance, and compartment implosion can be caused by a blocked drain or drain screen. Inspect and clean the drain and drain screen before each use.

Before every steaming operation, inspect the cooking compartment and remove any food scraps or debris from the racks, walls, and floor of the compartment. Pay attention to the drain and drain screen.

1. **DO NOT USE** the steamer if water stands in the drain opening. Arrangements must be made immediately to clean the drain in accordance with the instructions found in the **Preventative Maintenance** and **Troubleshooting** section of this manual.
2. Remove any food or debris that is blocking the drain or screen.
3. Be sure the screen covers the drain. The screen prevents large pieces of food from entering and blocking the drain.

C. Power On (Automatic Fill)

When each steamer compartment is turned ON, it automatically fills its steam generator with water. Use this procedure at the beginning of a shift to prepare the steamer for operation without starting steam generation.

1. Turn the ON/OFF switch to the ON position to energize the steamer control panel. The digital display on the control panel lights, the combustion blower turns ON to purge the generator and water fills the steam generator.

2. When the generator is full, the steamer automatically stops water flow.
3. Once the water has reached the minimum operating level, the blower turns OFF and the pilot/standby burner lights to heat the water to the standby temperature.
4. Timed Mode (with "SURE COOK" mode feature)
 - a) Select cooking time using "Control Knob".
 - b) Press "TIMER-START/STOP" button to start cooking.
 - c) "SURE COOK" illuminates on digital display once the compartment reaches 193°F (90°C).
 - d) Timer then starts to countdown until it reaches 00:00.
 - e) Steamer will stop heating and require prompt when the timer reaches 0:00.
5. Manual Mode (Continuous Steaming)
 - a) Press and hold "TIMER-START STOP" button for 5 seconds until switches to Manual mode.
 - b) "MAN" will appear on the digital display when activated and control knob disabled.
 - c) **NOTE:** steamer will go into "Standby" mode if compartment isn't opened for 60 minutes.
6. Changing from Manual to Timed Mode
 - a) Press and hold "TIMER-START/STOP" button for 5 seconds until switching to TIMED mode.
 - b) "TIMED" will appear on the digital display.
 - c) Digital display will display 00:00, Control knob activated.
7. "Delime" Notification
 - a) Easy Timer comes with 400 hours operation for "Deliming Notification."
 - b) After 400 hours, "DELIME" appears on digital display for 5 seconds and will re-appear every 5 minutes.
8. Reset and Clear Delime Notification
 - a) Turn OFF main power with POWER SWITCH.
 - b) Press and hold the "TIMER-START/STOP" button.
 - c) Power unit ON with main POWER SWITCH (with "TIMER START/STOP" Button held).
 - d) Wait 10 seconds to Reset/ Clearing Mode.
 - e) The Beeper starts beeping once every second.
 - f) Release the "TIMER-START/STOP" button.
 - g) Display will show "RST".
 - h) Press the "TIMER-START/STOP" button to confirm resetting delime notification.
9. Program Number of Hours until Delime Notification
 - a) Turn OFF main power with POWER SWITCH.
 - b) Press and hold the "TIMER-START/STOP" Button.
 - c) Power unit ON with main POWER SWITCH (with "TIMER START/STOP" Button held).
 - d) Wait 20 seconds to enter Programming Mode (to change the Max number of hours)
 - e) The Beeper starts beeping twice every second.
 - f) Release the "TIMER-START/STOP" button.
 - g) Display will show past settings.
 - h) Turn knob to adjust the number of hours.
 - i) Press "TIMER-START/STOP" button to save number of hours for next delime notification.

D. Lighting and Shutdown Instructions

DO NOT TRY TO LIGHT THE BURNERS OR PILOT WITH A FLAME. THE PILOT AND BURNERS ARE SELF IGNITING.

The Gemini Steamer has an electronic ignition system, which automatically lights the pilot and burners, senses the flame and controls gas flow. This provides precise burner control, safety ignition, and shutdown.

WARNING

DEATH, INJURY or EQUIPMENT DAMAGE may result from an improperly adjusted gas control and ignition system.

Do not alter any adjustments on this electronic control or gas valve. If adjustment is required, contact an authorized service center.

Cleveland Range is in no way responsible for the operation or safety of this equipment if the controller, valve, or igniter probe are adjusted by anyone other than a Cleveland Range authorized service representative.

The following START-UP SUMMARY is for quick reference ONLY. For safe operation and use of this equipment, the operators should comply with all safety and operating instructions in this manual.

1. Lighting Instructions

- a. Turn the ON/OFF switch to the ON position.
 - Blower will start, and boiler will fill with water (about 3 minutes).
 - Pilot will attempt to light for 90 seconds.
 - If no ignition occurs the system will automatically reset in 6-7 minutes.
- b. System may be reset manually by turning the ON/OFF switch to the OFF position for 5 minutes and then back to ON.
- c. Turn ON a cooking compartment.
- d. Blower will start, and main burner will light.
- e. Each compartment has its own control system and must be started independently.

2. Shutdown Instructions

Turn the ON/OFF switch to the OFF position. The burners and pilots will immediately be extinguished, and the unit will begin the automatic 3-minute blowdown cycle and drain.

NOTE: Each compartment has its own control system and must be shut off independently.

E. Preheating the Steamer

Preheating the steamers can help ensure that the best productivity and consistent cooking is obtained. To preheat each steamer, run a cooking cycle of approximately 15 minutes with no food in the cooking compartments.

NOTE: If using a steamer with a timer, set only a 1-minute cooking time for preheating, since the timer will only begin to countdown once the steamer has reached a cooking temperature.

- **BEFORE PREHEATING**, inspect and clean the compartment. After preheating, the compartment will be too hot to inspect and clean safely.

CHAPTER 6 SHUTDOWN AND CLEANING PROCEDURES

A. Steam Generator Blowdown

1. Power Off (Automatic Blowdown)

Blowdown occurs automatically when each steamer compartment is turned OFF at its ON/OFF switch. During blowdown, the steam generator drain valve is rinsed with fresh water, and the boiler is drained. Blowdown at frequent intervals helps decrease mineral buildup in the steam generators and reduces the frequency of descaling and other maintenance.

2. Blowdown Frequency

The supply water quality determines how often blowdown must be performed. The more the steamer is used and the higher the content of total dissolved solids and particulates in the feed water, the more frequently blowdown must be performed. A determination should be made at the time of installation whether additional blowdown frequency will be required as part of the daily maintenance based on the water quality analysis done as part of the installation. This information should be noted in the daily maintenance program developed for the equipment. After it has been determined whether the local water supply meets the minimum supply water quality standards, observe the following guidelines to establish proper blowdown scheduling.

- When using a supply water system that does not meet the minimum supply water quality standards, blowdown must be performed after every 4 hours of operation and at the end of each shift.
- For units using water that meets the minimum supply water quality standard, whether naturally or by using a water treatment system, blowdown must be performed at the end of each shift.

3. Blowdown Procedure

When each steamer is turned OFF, its blowdown cycle starts and runs automatically. The complete cycle takes approximately 3 minutes.

- a) Turn the ON/OFF switch to the OFF position to turn OFF the steamer. The digital display turns OFF and the drain valve is opened. Do not turn power OFF at the main external power switch during blowdown.
- b) The drain valve begins to draw water from the steam generator.
- c) The fill valve operates for 3 minutes to help flush any debris through the drain valve as the generator drains.
- d) At the end of the 3-minute blowdown cycle, the fill valve closes.
- e) When blowdown is complete, the steamer can be restarted, or the shutdown procedure completed.
 - To restart the unit, refer to POWER ON (AUTOMATIC FILL) in Chapter 5.
 - To shut down the unit, refer to SHUT DOWN AND CLEANING, below.

NOTE: The ON/OFF switch must be turned fully to the OFF position to properly START the automatic blowdown of the steamer.

B. Shut Down and Cleaning

This procedure should be performed at the end of each day or shift.

WARNING

Do not use a hose or water jet to clean this appliance.

1. Refer to Power OFF (Automatic Blowdown) and turn off the steamer compartment. Allow 3 minutes for the complete blowdown cycle.
2. Open the steamer door and allow steamer to cool.

⚠ WARNING

Inside of steamer stays hot for a long time. Be careful when cleaning inside steamer compartment.

3. Remove the slide racks. Wash and rinse racks separately or clean them in a dishwasher according to health requirements. Do not remove the drain screen.
4. Remove any spilled food from inside compartment and clear any residue from the drain screen. Clean the interior of the compartment thoroughly. Use a soft bristle brush to remove stubborn food particles. Do not use abrasive cleaning compounds or steel wool. Rinse inside of steamer compartment with clean water.

⚠ WARNING

Let rinse water drain through compartment drain opening. If water does not drain freely, drain lines must be cleaned before cooking again. Clogged or slow drains are dangerous because hot water can collect in compartment and spill out when opening compartment door.

5. Clean the door assembly.
 - Remove the door gasket assembly (see Figure 6-1).
 - Note the keyhole slots on the door and the retaining pins on the gasket assembly. Grasp the gasket assembly at the sides and lift up and towards you to remove the assembly.
 - Clean all surfaces of the gasket assembly, as well as the inside of the door, by wiping with a damp cloth.
 - Rotate the gasket assembly 180° and replace it by sliding the retaining pins into the keyhole slots. Either long edge of the gasket assembly can be positioned at the top. Periodic rotating of the door assembly will increase the door gasket life.
6. Replace the cleaned slide racks.
7. Wipe the exterior with a damp cloth only. **NEVER HOSE DOWN THE STEAMER.** Electrical components inside the unit will not function correctly if wet or damp.
8. After cleaning, leave the steamer door open until the next steamer operation. This prevents compartment odor buildup and increases gasket life.

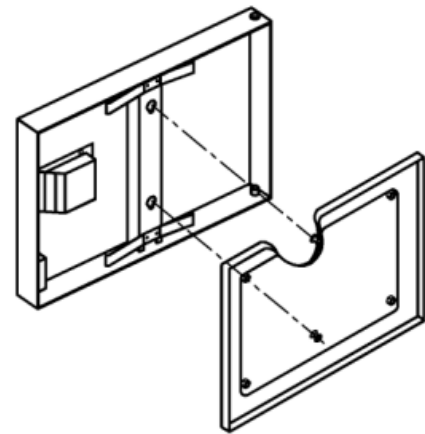

Figure 6-1
Door Gasket Assembly

CHAPTER 7 OPERATING TESTS AND FINAL CHECKOUT PROCEDURES

A. Burner Ignition Test (Lighting and Shutdown Instructions)

It is recommended that this test be performed before beginning the Startup Test Procedure. This will ensure that the basic heating system is operating normally before reviewing the overall operation of the steamer, since much of the operation is dependent on the operation of the burner control system.

1. Lighting Instructions

This is a functional test of the intermittent pilot ignition system. Pilot/burner ignition is completely automatic.

NOTE: Each compartment has its own steam generator and control system and must be started independently.

a. If not already done during prior installation or testing:

- Test the water supply lines.
- Leak test the gas supply lines.
- Turn the Main Manual gas valve to the open position.

b. The controls should be set as follows:

- The main power switch should be in the OFF position.
- The steamer's ON/OFF switches should be set to the OFF position.
- The steamer should be set to TIMED mode.

c) Turn ON the electrical power to the steamer at the main power switch.

NOTE: When initial power is supplied to the steamer with the ON/OFF switch in the OFF position, a 3-minute blowdown cycle starts. This blowdown cycle stops when the 3 minutes have elapsed, or the ON/OFF switch is changed to the ON position.

d) Turn ON the electrical power to the steamer at the ON/OFF switches.

- i. The digital display on the control panels light and water begins filling the steam generator. The pilot/burners do not light until water reaches the safety level in the probe assembly.
- ii. After 2 to 3 minutes, water reaches the middle probe (safety level).
- iii. Turn on a cooking compartment and the burners will light with a distinctive sound.

NOTE: Cooking compartment doors must be closed first.

- If the burners light within 5 minutes of turning the unit ON, the ignition controls are functioning normally. End this test procedure here.
- If the burners do not light within 7 minutes, there may be air in the gas supply lines proceed to step e.

e) Turn off electrical power to the Steamer, at both the ON/OFF switches and the main power switch.

NOTE: When the burners fail to ignite, a safety circuit in the igniter control de-energizes the system and closes the automatic gas valve. The safety circuit resets when the steamer's power is turned OFF and then back ON.

f) Wait 5 minutes and then repeat steps b through e. If this is a brand-new installation, or an excessive amount of air in the lines is suspected for any other reason, it may be necessary to bleed the excess air from the lines. This should be done at a union or connection as close as possible to the inlet of the automatic gas valve.

g) If the burner does not light after the third attempt, call a Cleveland Range authorized service representative to adjust the burner controls.

h) Go to Shutdown Instructions.

2. Shutdown Instructions

- a. Turn off electrical power to the steamer, at both the ON/OFF switches and the main power switch.
- b. Turn off gas supply at the main manual gas valve.

B. Startup Test Procedure Gas Gemini

After performing the startup procedure, perform the test procedure as appropriate to the control panel on the steamer being tested. Ignore any steps which do not apply to the steamer being tested. Read through all steps of this procedure before starting. Complete the startup procedure before starting the actual operating tests. **This procedure should be performed only by a service technician or installer.**

NOTE: Each compartment has its own steam generator and control system and must be started independently.

1. Startup Procedure

- a) Check that the water supply line valves are open.
- b) Check that the main manual gas valve is open.
- c) Open the steamer door. Check for proper installation of the drain screen, slide racks, and door gasket assembly. Be sure the drain is not blocked. Shut the steamer door.
- d) Refer to electrical layout, Figure 3-7, and spec sheet. Be sure the main power switch is in the OFF position. Verify installation of the proper size fuses or circuit breakers.
- e) Set the ON/OFF switch to the OFF position.
- f) Remove the right-side access covers.

WARNING

DEATH, SEVERE ELECTRICAL SHOCK or EQUIPMENT DAMAGE can result from touching any component inside unit when main power switch is in the ON position. Use extreme caution during testing with the access cover removed.

2. Blowdown Inspection (continue from Startup Procedure)

- a) Turn ON electric power to the steamer at the main external power switch. The steamer will immediately start a 3-minute blowdown cycle. During blowdown, the fill and drain valves are fully open while the steam generator drains are flushed with fresh water.
- b) Stop the blowdown cycle before it is complete by setting the ON/OFF switch to the ON position. This energizes the operating control circuits, the digital display on the control panels light, blowdown stops, and the steam generator fills with water.
- c) After automatic filling, Restart the blowdown cycle by setting the ON/OFF switch to the OFF position. During the automatic blowdown cycle, make the following checks.
 - Check for plumbing leaks.
 - Look at the one-inch vent gap between the steamer drainpipe and the floor drain. A steady stream of water should be draining from the steamer.
 - After about 3 minutes, the cycle is complete. Check the gap at the steam drain; there should be no more water flow at this point.

3. Operating Tests and Final Checkout Procedure (Continue from Blowdown Inspection) (Sequence of Operation)

- a) At the start of this test the controls should be set as follows:
 - The main external power switch is ON.

- The ON/OFF switch is OFF (The digital display on the control panels are not lit).
- b) Set the ON/OFF switch to the ON position. As the steam generator fills with water, check the following functions.
- i. The digital display turns ON. The fill valve opens, and water begins to fill the steam generator. The combustion blower turns on to purge the combustion chamber.
 - ii. After a few minutes, water appears in the bottom of the probe cylinder. As the water level in the steam generator rises;
 - Check that no water flows from the drain opening.
 - Check for plumbing leaks.
- c) When the water in the steam generator reaches a safe operating level (which is the level of the middle probe), the combustion blower shuts off and the pilot ignition cycle starts. The steam generator begins to heat the water to stand-by temperature by lighting the pilot/standby burner.
- i. Water continues to fill the generator and the water level in the probe cylinder continues to rise.
 - ii. The water in the probe cylinder stops rising when water reaches the upper probe.
- d) If the water level continues to rise above the tip of the higher probe, have a qualified service representative check the probe circuit. Switch both compartments to MANUAL mode so the steaming cycle starts. Check the following functions.
- If the water level in the steam generator is above the lower probe, the heating components turn ON and begin to heat the water to steam.
 - After a few minutes steam begins to enter the compartment from the nozzles. A small quantity of water may drip from the nozzles until steam clears the lines.
 - After a few more minutes the compartment will reach cooking temperature. When the compartment reaches cooking temperature:
 - 24CGA6.2S & 24CGA10.2 (high capacity) units - the thermostat will close, the condenser solenoid clicks open and condenser flow starts. A small stream of water flows from the drainpipe. If no drain water flows, check that the water supply valves are open, and the lines are connected properly.
 - STEAMSAVER™ 24CGA10.2ES (high efficiency) units – the SURECOOK™ thermostat will close. The burners will soon begin to cycle on the compartment operating temperature thermostat. The condenser solenoid clicks when the condenser box has reached maximum drain temperature. A small stream of water flows from the drainpipe. The water stops when the drain water has cooled to the proper temperature.
 - With the unit in manual cooking mode the unit should steam continuously or cycle on compartment temperature, depending on model, until turned OFF, set to the timed cooking mode, or when the energy saver timer is activated (See Note below). After several minutes of steaming, check for steam leaks around the door gasket.
- e) As the unit continues to steam in Manual Cooking Mode, test the no-water/low water safety circuit.
- Close the steamers manual water supply valve. Observe the steam generator probe cylinders while steaming continues.
 - As water steams out of the generator, the water level drops below the low water safety cutoff point. The steamer should automatically shut off.
 - Re-open the manual water supply valve. The steamer's controls automatically refill the steam generators with water to the safety level and resumes steaming.
- f) When the steamer is set to TIMED mode and the timer is zeroed, the steam generating cycle stops.

- The main burners turn OFF, and the condenser flow stops* (*models 24CGA6.2S & 24CGA10.2 only).
 - Steam stops entering the cooking compartment.
- g) Open the cooking compartment door to vent the steam and allow the compartment to cool slightly. After 2 or 3 minutes, close the door and continue testing.
- h) With the compartments set to TIMED mode, set the timers of both compartments for 10 minutes.
- i) When the START/STOP key is pressed, the steam generating cycle starts. This is the same sequence observed in steps **d** and **f**, except:
- The timer controls the cycle.
 - The elapsed time to produce steam is shorter because the water in the steam generator and the cooking compartment were preheated during step **d**.
 - The timer automatically starts the step **f** functions after counting down to zero.
- j) After the timed operation has been started, observe the following steam generating functions.
- i. The SURECOOK™ digital display comes ON until the cooking compartment reaches cooking temperature. When it does, the timer begins counting down to zero, and the SURECOOK™ digital display turns OFF.
 - ii. When the unit reaches temperature:
 - 24CGA6.2S & 24CGA10.2 (high capacity) units - the condenser solenoid clicks open and condenser flow starts. A small stream of water flows from the drainpipe.
 - STEAMSAVER™ 24CGA10.2ES (high efficiency) units – the burners will begin to cycle on compartment temperature, the condenser solenoid clicks when the condenser box has reached maximum drain temperature. A small stream of water flows from the drainpipe. The water stops when the drain water has cooled to the proper temperature.
 - iii. If the probe cylinder water level drops below the upper probe, 15 to 20 seconds later the water fill valve opens and fills the generator. When the probe cylinder water level is above the middle probe, the burners turn ON. A dull roaring sound indicates the burners are firing and the unit is generating steam.
 - iv. As the unit generates steam, the water level fluctuates and a clicking sound is heard as the solenoid opens and closes the fill valve. The level in the cylinder rises and falls between the upper and lower fill limit as the fill valve operates.
 - v. Check for steam leaks around the door.
 - vi. When the timer counts down to zero, the burners turn OFF, the condenser flow stops* (*models 24CGA6.2S & 24CGA10.2 only), and the buzzer sounds for 3 seconds.
 - vii. After about 30 seconds steam stops entering the cooking compartment.
- k) Turn the steamer OFF by turning the ON/OFF switch to the OFF position. The digital display turns OFF immediately, and the automatic blowdown cycle starts. DO NOT turn OFF the power at the main power switch until blowdown is complete. The cycle takes about 3 minutes.
- l) When blowdown is complete, turn the steamer OFF at the main power switch.
- m) Install the side panels and secure them in place with the screws. After completing the Startup and Blowdown Inspection procedure, and the Operating Test procedure; the steamer is ready for service. Refer to the OPERATORS section for complete operating instructions.

CHAPTER 8 PREVENTATIVE MAINTENANCE

A. Maintenance

Maintenance on the steamer must be performed on a regular basis to keep the unit running properly. By following the maintenance instructions in this chapter and referring to installation section, problems with the steamer will be kept to a minimum. As with any preventative maintenance schedule, the frequency of steamer maintenance may need to be increased, depending on equipment usage and water quality. If problems do occur, refer to the **Troubleshooting Guide** in this chapter. For more information on products and services, contact your sales representative.

1. Maintenance Records

Make a file solely for maintenance records. Keep a written record of daily, weekly, monthly, and yearly maintenance. These records will protect warranty coverage, help personnel to know when to perform various maintenance procedures, and assist service personnel.

2. Daily Maintenance

a. Blowdown Steam Generator

Blowdown each steam generator according to the steam generator blowdown instructions in Chapter 6.

b. Clean the Steamer

Clean interior and exterior of the steamer according to the shutdown instructions in Chapter 6.

3. Weekly Maintenance

Clean Drain

CAUTION

Steam leaks, pressure buildup in the cooking compartment and poor steaming performance can be caused by a blocked drain line or screen. Blocked or slow drains are dangerous because hot water can collect in the compartment and spill out when opening the compartment door.

This steamer is equipped with a drain screen in the back of each cooking compartment. Never operate the steamer without the screens in place. The screen prevents large food particles from entering and blocking the drain line. Any blockage of the drain line can cause a pressure buildup in the compartment, resulting in steam leaks around the door gasket. Drain line blockage also adversely affects convection action of the steam in the compartment, which is necessary for optimum performance.

- Inspect the drain screen and drain line for blockage. Rotate the drain screen 90 degrees to inspect the drain opening. Clean the opening and restore the screen to its operating position.
- Clean drain with a USDA approved drain cleaner, once a week. Follow the instructions of the manufacturer of the cleaner.
- Flush drain with clean water.

4. Monthly Maintenance

Descale Steam Generator

Steam generators should be descaled at least once a month, depending on scale buildup. If you have serious steam generator scale buildup, a water treatment system should be installed for the steamer or if this is not possible the frequency of descaling should be increased.

Cleveland Range, recommends the use of **DISSOLVE® Descaler Solution, Cleveland Range Part No. 106174**. No other system of steamer descaling should be used.

NOTE: Part No. **106174** is the Part No. for a case (6 1-gallon containers) of DISSOLVE® descaler. It is also available in 5-gallon containers as Part No. **1061741**.

THESE INSTRUCTIONS ARE FOR USE WITH DISSOLVE® DESCALER SOLUTION Cleveland Range Part Nos. 106174 or 1061741 ONLY.

- **Health Hazard Data, Effects of Overexposure** – This product may cause a burning sensation to eyes or skin.
- **Emergency and First Aid Procedures** – In case of eye contact, immediately flush eyes with plenty of water. If irritation persists, seek medical attention. In case of skin contact, wash with soap and water. If inhaled, remove to fresh air and if burning persists, call a physician. If swallowed, drink 1 or 2 glasses of water and call a physician.
- **Spill or Leak Procedures** – Rinse with plenty of water to dilute. Sodium carbonate or calcium carbonate may be used to soak up liquid. Considered non-hazardous, spent material may be disposed of in a sewer system with water flush.

⚠ WARNING

The liquid solution in Cleveland Range Descaler Solution Part No. 106174 or 1061741 can be harmful if not handled properly. Follow these basic safety rules for handling and using this product.

Wear protective clothing when mixing or applying chemical cleaners.

Wear rubber gloves, and OSHA approved eye protection when descaling to avoid personal injury.

Avoid breathing fumes. If liquid comes in contact with skin, wash with soap and water.

If chemical contacts eyes, flush with water. If irritation persists, seek medical attention

If chemical is swallowed or ingested, drink 1 or 2 glasses of water and call a physician.

⚠ CAUTION

Do not use any other product or method of descaling other than the DISSOLVE® Descaler method using Part Nos. 106174 or 1061741.

- a. **MODEL 24CGA6.2S, 24CGA10.2, and the STEAMSAVER™ 24CGA10.2ES, ATMOSPHERIC STEAM GENERATOR DESCALING PROCEDURE (For DISSOLVE® Descaler Solution Part No. 106174 or 1061741)**

Monthly Intervals

1. This procedure will take approximately 1 hour and 30 minutes to complete

⚠ WARNING

This procedure is slightly different depending on the model. This entire procedure should be read and fully understood as it applies to the model being descaled, before beginning the actual descaling operation.

2. Open both doors to the cooking compartments.
3. Set both ON/OFF switches to the OFF position. (The unit will undergo a normal blowdown cycle, which should take approximately 3 minutes to complete).
4. Remove both caps from the descale ports located at the top of the unit (See Figure 8-1),
5. When the unit has completed draining, set both ON/OFF switches to ON, this will refill the generators. Do not start the timer and leave the cooking compartment doors open.

NOTE: DO NOT HEAT THE UNIT DURING DESCALING.



Figure 8-1 Descaling Port

6. While the unit is filling with water add 1 gallon of DISSOLVE® descaler solution into each descaling port.
 - While adding liquid to the unit through the descaler inlets, pour it in slowly to avoid overflow.
7. After the automatic fill cycle has ended, turn OFF power at the external main power switch. See Figure 8-2. DO NOT change the position of the ON/OFF switch.

(FOR THE MODELS 24CGA10.2 and The STEAMSAVER™ 24CGA10.2ES ONLY add cold tap water through one descale port until water enters the cooking compartment through the steam nozzles or until the descaling port overflows (water required varies between 1 to 2 gallons depending on the Model). Repeat with the second descale port.)

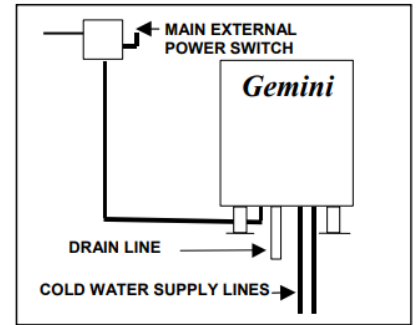

Figure 8-2
Main External Power Switch

8. At the end of 1 hour, set the ON/OFF switches to the OFF position, which will drain the generators (takes about 3 minutes).
9. Restore power to the unit by turning the power back ON at the external main power switch.
10. Set both ON/OFF switches to ON to refill generator. When full, add ½ to 1 gallon (1 to 1½ Gallons for the Model 24CGA10.2) of water through each descale port (to remove foam from the water level controls)
11. Set both ON/OFF switches to OFF to drain the generators.
12. After the unit has drained completely, close the steamer doors and set the ON/OFF switches to the ON position. The unit will fill with water.
13. Set the timers for 20-30 minutes. The unit will come up to normal operating temperature.
14. At the end of 20-30 minutes of cooking, turn OFF the alarm (if necessary) and set the ON/OFF switches to the OFF position to drain the generators. Wait at least 5 minutes to ensure complete draining.
15. This is the final blowdown to rinse the unit. The steamer is now ready for normal operation.

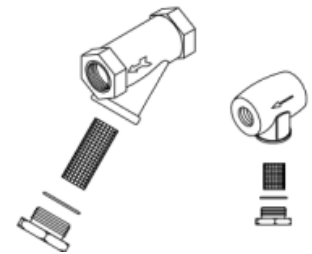

Figure 8-3
Water Strainer Assembly

5. Yearly Maintenance

Clean Water Line Strainer

Clean the water line strainer at least once a year as follows:

NOTE: When the steamer is first installed, check the strainer more frequently to find out how often it must be cleaned.

1. Close the valve(s) in the steamer water supply line(s).
2. Unscrew the filter cap from the bottom of the strainer. Refer to Figure 8-3, which shows the various strainers supplied with the different steamers.
3. On some models the strainers are built into the steamer and are accessible from underneath the steamer (See Figure 8-4), otherwise the strainers should be installed upstream of the steamer in the water supply(s).
4. Remove the filter screen and wash it with clean water.
5. Check the O-ring for wear and replace it if necessary.
6. Put screen back into cap and replace the cap in the strainer.
7. Open water supply valve(s) and check for water leaks.



Figure 8-4
Pre-installed
Water Strainer Assembly

CHAPTER 9 TROUBLESHOOTING GUIDE

The Troubleshooting guide includes a list of symptoms that may be encountered during routine operation and maintenance.

The first column on the left (PROBLEM) describes these symptoms.

The second column lists the possible causes for the problem in column one.

The third column lists possible remedies for the problems and causes in columns one and two.

The causes and remedies are listed in the order they should be checked, with the least costly and easiest to repair listed first.

The third column also refers to notes that are grouped at the end of the troubleshooting guide. Refer to these notes when instructed to do so. Do not try and correct a problem, which requires an authorized service representative as this may adversely affect warranty coverage.

Table 9-1 Trouble Shooting Guide

PROBLEM	POSSIBLE CAUSE	REMEDY/REFERENCE
Digital display does not turn ON when ON/OFF switch is in the ON position.	Power turned OFF at main external power switch or breaker.	Turn ON power at main external power switch or breaker.
	ON/OFF switch not fully turned to the ON position.	Turn switch to the full ON position.
	Inoperative controls or failed light.	See note #1.
Power ON and steam generator does not fill.	Water supply to steamer shut off.	Open water supply valves.
	Water line strainer and/or external filter system is clogged.	Clean water supply strainer and/or filter system.
	Inoperative Solenoids or controls.	See note # 1.
Digital display turns ON and steamer does not make any steam in MANUAL or TIMED modes.	Water supply to steamer shut OFF.	Open water supply valves.
	Door interlock switch not engaged or has failed.	Close door completely. If problem persists see note #1.
	Hi-limit switch has tripped.	Reset Hi-limit (See note # 9). If condition persists, see note #1.
	Water line strainer and/or external filter is clogged.	Clean water supply strainer and/or external filter system.
	Gas supply valve is closed.	Turn OFF unit and open gas supply valve.
	Steamers gas valve is closed.	Turn gas valves to open position.
	Inoperative controls or solenoid.	See note # 1.
Abnormal amount of steam coming from drain.	Hot water instead of cold water connected to condenser fitting.	Make proper connections. See section on Water Supply.
	Water supply to condenser turned OFF.	Open water supply valve.

	Condenser water line strainer and/or nozzle is clogged.	Clean out condenser water supply strainer and/or nozzle.
	Water supply line to the condenser blocked, broken, or leaking.	Repair or replace water supply line. See note # 1.
	Inoperative controls, thermostat or solenoids.	Turn OFF electricity at main external power switch. See note # 1.
Reduced steam flow into cooking compartment.	Steam generator scale buildup.	Descale steam generator with Cleveland Range approved descaler.
	Gas inlet pressure is low.	The unit requires a minimum inlet pressure of 4.5 in. W.C. for NATURAL GAS, or 11 in. W.C. for LIQUID PROPANE, to operate. See note #2.
	Inoperative or improperly adjusted controls.	See note #1.
Power light is ON, but timer does not light.	Timer transformer has failed.	See note #1.
	Inoperative controls.	See note #1.
Steam and/or water draining around compartment door. See Warning under note #7.	It is common for a small amount of water to condense around the door.	This is normal operation of the unit. No action is necessary.
	Compartment drain clogged or covered.	Clean drain with USDA approved drain cleaner. If condition persists, see note #1.
	External drain not properly installed, should be free-air vented and pitched down.	See notes #2 and #3.
	External drain is blocked or restricted.	Clean external drain. See note #3.
	Door gasket or door parts worn.	See note # 1.
	Steamer not level.	See note # 2.
	Condenser solenoid not operative. (high capacity units only)	See note #1.
	Condenser box solenoid not operative. (high efficiency units only)	See note #1.
Steam flow does not stop when TIMER stops.	Operating in manual mode.	Switch to timed mode for timer to be effective.
	Inoperative controls inside cabinet.	Turn OFF power to that compartment at ON/OFF switch. See note # 1.
Compartment bottom dirty with food drippings.	Juices and/or food leaking from pans.	Put a solid pan under perforated pans to catch drippings, or put less food in pan.

Water leaking from bottom of cabinet.	Broken or loose plumbing inside steamer cabinet.	Turn OFF electricity at main external power switch and close water supply valve(s). See note # 1.
Water leaking from water pipes or drain lines.	Plumbing needs repair.	See note # 3.
Abnormal amount of steam coming from drain during blowdown cycle.	ON/OFF switch is not turned fully to the OFF position.	Turn ON/OFF switch to the full OFF position to start the proper blowdown operation.
ON/OFF Indicator on but steamer does not make steam in timed mode.	Timer fuse has blown (Electronic timer models only).	See note #1.
	Inoperative timer control or damaged wiring.	See note #1.
Food takes too long to cook. To verify the steamers proper operation see note #6.	Pans too close to the bottom of cabinet.	Put pans in racks near top of cabinet.
	Not enough steam movement in compartment. Hot water connected to condenser line.	Make proper connections. See section on Water Supply. See note # 3.
	Steam generator scale buildup.	Descale steam generator with Cleveland Range approved descaler.
	Compartment overloaded with too much food.	Put less food into pan. Use fewer pans.
	Condenser water is turned OFF.	Turn ON water to condenser.
	Condenser water line strainer and/or nozzle is clogged.	Clean out condenser water supply strainer and/or nozzle.
	Food is frozen.	Increase cooking times for frozen food.
	Food is being cooked in covered solid pans.	Remove covering. Steam must have direct access to the food for cooking to take place.
	Suggested cooking times are usually listed for cooking at sea level.	Extend cooking times for altitudes above 2500 feet.
	Inoperative or improperly adjusted controls.	See note #1.
Water is flowing out of the steam ports into the cooking compartment.	Water level probes are dirty and are not sensing properly.	Turn OFF the water supply to the steamer and descale the unit manually with Cleveland Range approved descaler by filling the unit with descaler and water through the descaling port. If the condition persists see note #1.
	Inoperative controls or solenoid.	See note #1.
Water comes out of descale port.	Descal cap is missing.	Install the descale cap. Descal port must be closed tightly for the steamer to operate properly. If missing see note #8.

	Descalcap is loose.	Tighten the descalcap. The descalcap port must be closed tightly for the steamer to operate properly.
	Descalcap and/or gasket is damaged.	See note #8.
Water coming from drain even when not cooking.	Condenser valve is bad.	See note #1.
Steam and/or water issuing from small valve at the top of each steam generator.	Steam generator scale buildup.	Descalcap steam generator with Cleveland Range approved descalcap. If condition persists see note #1.
	Inoperative control.	See note #1.
Water backs up into cooking compartment during generator blowdown.	Condenser box needs cleaned. (high efficiency units only)	Clean drain with USDA approved drain cleaner. If condition persists see note #1.
	External drain not properly installed, should be free-air vented and pitched down.	See notes #2 and #3.
	External drain is blocked or restricted.	Clean external drain. See note #3.
Easy Timer display has noise/disruptions.	Power surge/not clean power.	Recommended power surge bar to resolve rare EMI/power disruptions.

TROUBLESHOOTING NOTES

1. If problem is inside the steamer, call an authorized service representative. Cleveland Range will not pay for warranty repairs by unauthorized repair centers.
2. Proper installation of the steamer is the responsibility of the owner or installer. A qualified installer or technician should be contacted to correct the installation. Refer to Cleveland Range Warranty.
3. Repairs to external plumbing should be done by a Licensed Plumber.
4. Repairs to external wiring should be done by a Licensed Electrician.
5. For more information on products and services, contact your nearest Authorized Sales Representative. Call factory for a preventative maintenance program, descaling kits, descaling information, and water treatment systems: USA: (800) 338-2204, Canada: (800) 427-6668.
6. To evaluate whether a steamer is producing normal cooking performance, conduct the Egg Test as follows (NOTE: this test is not valid for pressure steamers). A properly operating steamer will produce cooked eggs as follows.

Turn on the steamer so that steam is being produced. When wisps of steam have begun to exit the steam vent, preheat the steamer by leaving it ON for ten minutes. After the compartment is preheated follow the instructions as listed below.

- Place a fresh egg on a perforated steam table pan in the middle of the cavity.
- Close the door and set the timer as directed by the size chart below.

Egg Size	Time
Medium	12 minutes
Large	14 minutes
Extra Large	14 minutes

- When time is complete, carefully remove the egg and place in a container with cold water running over it.
- Let cool under cold running water for 5 minutes.
- After cooling, crack eggshell and peel.

The result will be a perfectly hardboiled egg.

7. Whenever opening door, especially when water or steam is leaking around gasket heed the warning below

WARNING

When checking inside the steamer always open the door slowly and stand to the side and back away from the steamer. Water leaking from the door gasket can be a sign of a blocked drain. If the drain is blocked, hot water can accumulate inside the compartment and spill out when the door is opened.

8. Replacement descale caps and gaskets can be ordered from a Cleveland Range authorized maintenance and repair center.
9. To reset high limit:
 - Turn off power to the unit at the main external power switch.
 - Remove side panel(s) on the side of the unit that the generator high limit has tripped.
 - Follow the metal capillary from the side of the generator to the high limit.
 - Remove the small black cap, by turning it counterclockwise, and depress the small black button found under the cap to reset the limit.
 - Replace the protective cap on the hi-limit and side sheeting.
 - If the unit has not been descaled recently, descale the steamer according to the instructions found in the operator's manual.
 - If the unit has just been descaled. Close the steamer drain valve and fill the generator manually through the descale port, until water begins to come out of the steam ports in the cooking compartment.
 - Turn on power to the unit at the main external power switch.
 - If problem persists, see note #1.

Cleveland

Cleveland Range, LLC
760 Beta Drive, Unit D
Mayfield Village, Ohio 44143
216.481.4900
800.338.2204

Every new piece of Welbilt Foodservice equipment comes with KitchenCare® and you choose the level of service that meets your operational needs from one restaurant to multiple locations

StarCare – Warranty & lifetime service, certified OEM parts, global parts inventory, performance audited

ExtraCare – CareCode, 24/7 Support, online/mobile product information

LifeCare – Install & equipment orientation, planned maintenance, KitchenConnect™, MenuConnect®

Talk with KitchenCare® • 1-844-724-CARE • www.mtwkitchencare.com



To learn how Welbilt Foodservice and its leading brands can equip you, visit our global web site at www.welbilt.com, then discover the regional or local resources available to you.