

Parts Manual

Floor Type Gas Convection Steamer



Series: SteamCraft Model 24CGP10

1333 East 179th Street
Cleveland, Ohio 44110

Phone: (216) 481-4900
1-800-338-2204

Fax: (216) 481-3782
www.clevelandrange.com

 Cleveland

NOTES:

- 1.) SEE DRAWING 106737 FOR HOSE DETAIL.
- 2.) SEE INSTRUCTION DRAWING 106759 FOR LABELS AND LABEL LOCATIONS.
- 3.) REVISION SYMBOLS (Δ) ARE PLACED NEXT TO AFFECTED ITEM NO. IN BILL OF MATERIALS ONLY.
- 4.) FOR STEAM OUT-OFF SWITCH OPTION SEE DRAWING 106888 FOR LOCATION OF HOLES IN FACEPLATE AND DRAWING 106355 FOR PICTORIAL WIRING INFO.
- 5.) SEE DRAWING 107030 FOR BOSTON CHIGEN POWER TAKE-OFF PARTS LIST OPTION AND DRAWING 107031 FOR BOSTON CHIGEN POWER TAKE-OFF CUSTOMER CONNECTION KIT.

TABLE I

ITEM NO.	QTY	UNIT
105619 SCREW	41	1
105612 GUARD	40	2
104196 SWITCH	28	2
106192 DOOR	1	2
104202 DOOR	1	1

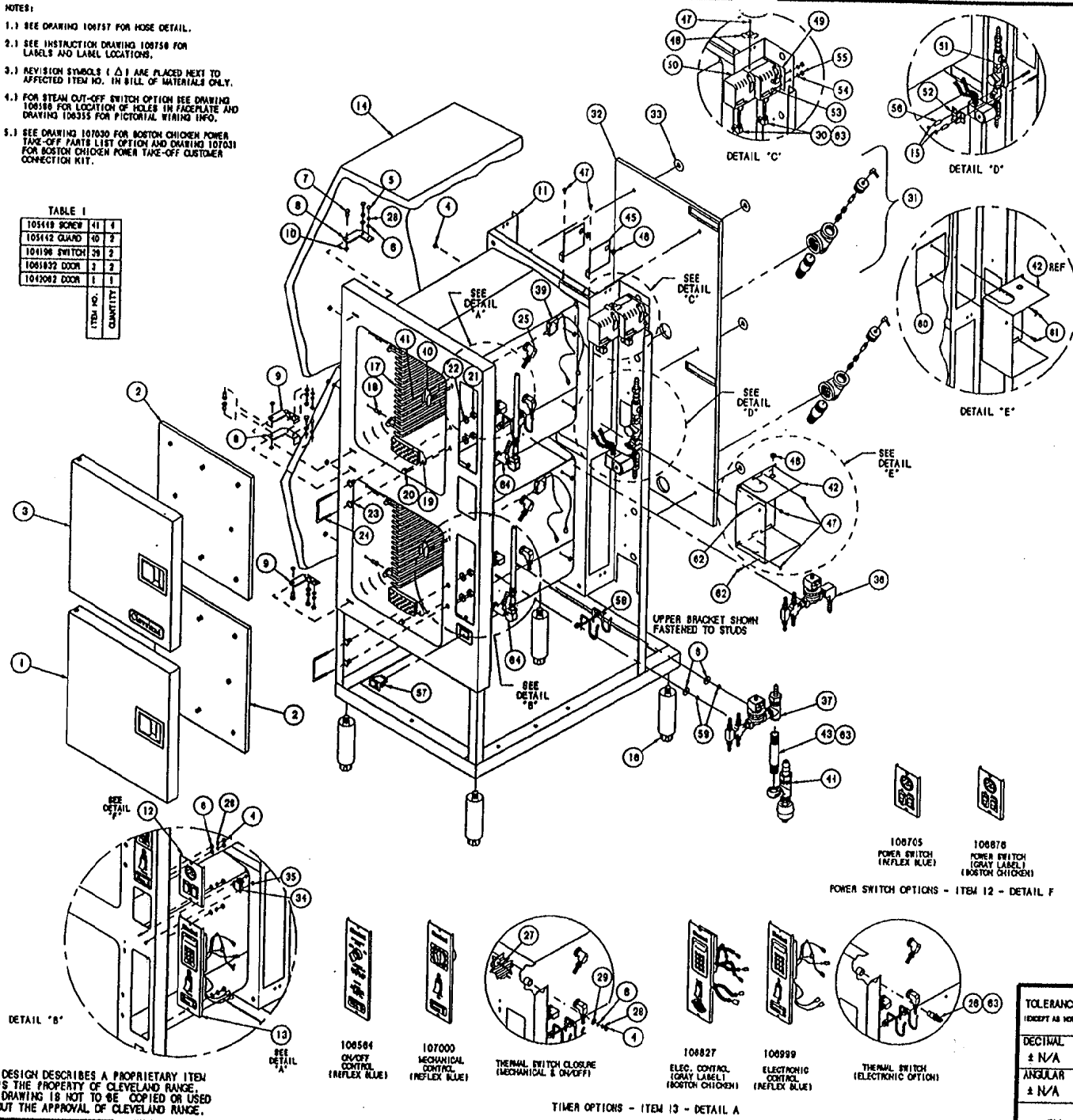

LET.	REVISIONS	E	BY
A	ADDED PARTS PER E.O. #2610	05-09-94	FJO
B	SEE E.O. 10-2688	07-05-94	FJO
C	SEE E.O. 10-2682	12-05-94	FJO

ITEM NO.	QTY	PART NO.	DESCRIPTION		
Δ 41	2	107039	BREATHER/SPRAY NOZZLE ASSY. (3/4" HORN)		
63	A/R	100934	BEALM, RECTORSEAL		
42	2	106126	SCREW, HEX HEAD, 1/4-20 X 1		
81	2	19170	SCREW, HEX HD, 1/4-20 X .425, 6/8		
40	1	106917	PLATE ASSY, FLOAT ENCLOSURE SUPPORT		
58	4	14972	NUT, LOCK ELASTIC		
57	1	10994	SWITCH, ROCKER, SFST (CLEAN LIGHT)		
50	2	106840	TUBING, 3/16" I.D. X 1" LG.		
55	2	14888	NUT, HEX JAM 1/4-20, 6/8		
54	2	23137	WASHER, LOCK INTERNAL TOOTH, 1/4"		
53	2	19216	SCREW, HEX HEAD, 1/4-20 X .375, 6/8		
52	1	106064	BRACKET, MOUNTING CLAMP		
31	1	106702	WATER FEED ASSEMBLY		
50	2	19947	SWITCH, PRESSURE CONTROL		
40	1	528241	BRACKET, PRESSURE SWITCH		
48	1	52199	BRACKET, PRESSURE SWITCH RETAINER		
47	0	19148	SCREW, HEX WASHER HEAD, 1/4 X .300		
46	3	82618	HYDRO BUSHING 3/8 X 3/8 X 1 1/2 HIGH		
45	2	106726	BRACKET, SAFETY CABLE SUPPORT		
44	1	106953	STEAM OUTLET ASSEMBLY		
43	1	14358	NUTFLUT, 3/4 X 8 LG.		
42	1	106857	SECURITY BOX, FLOOR, STEERBACK		
41	1	106728	SECURITY BOX, FLOOR, TOP		
40	1	106727	SECURITY BOX, FLOOR, BOTTOM		
SEE TABLE I		41	105449	SCREW, YALUB NO. 6-32 X .312, 6/8	
SEE TABLE I		40	105442	GUARD, SWITCH PROTECTION	
SEE TABLE I		39	104196	SWITCH ASSY, CAPT. STEAM SHUT-OFF	
SEE TABLE I		38	1068119	WIRE HARNESS, ON/OFF, 6C10	
SEE TABLE I		37	1068118	WIRE HARNESS, MECH. CONTROL, 6C10	
SEE TABLE I		36	1068117	WIRE HARNESS, ELECT. CONTROL, 6C10	
SEE TABLE I		35	1068116	STEAM INLET ASSY, LOWER COMPARTMENT	
SEE TABLE I		34	1068115	STEAM INLET ASSY, UPPER COMPARTMENT	
SEE TABLE I		33	2	104223	NUT, ELASTIC LOCK, 6-32
SEE TABLE I		32	1	14188	TERMINAL BLOCK, 2-POLE
SEE TABLE I		31	6	101935	CLIP, INSULATION RETAINER
SEE TABLE I		30	1	106235	INSULATION, BODY REAR
SEE TABLE I		29	2	1061711	DRAIN ASSEMBLY, 6C10
SEE TABLE I		28	2	06196	FITTING, COPP., 3/8" Y X 1/4" WPT, 60°
SEE TABLE I		27	2	23136	WASHER, FLAT 3/8 X 7/8 X 1/16 THK.
SEE TABLE I		26	12	23105	WASHER, LOCK 6/8 X 1/4 BATHING STYLE
SEE TABLE I		25	2	104409	CLOSURE, THERMAL OPENING
SEE TABLE I		24	2	19972	SWITCH, THERMAL CLOSE
SEE TABLE I		23	6	106200	STEAM NOZZLE ASSY, STEAMCRAFT
SEE TABLE I		22	2	104016	CATCH, DOOR
SEE TABLE I		21	4	14886	NUT, DOOR CATCH MOUNTING, 6/8
SEE TABLE I		20	4	23148	WASHER, FLAT, TYPE 6/8
SEE TABLE I		19	2	14848	NUT, HEX 1/2-13, ZINC PLATED
SEE TABLE I		18	2	14877	NUT, ACORN
SEE TABLE I		17	12	19092	SCREEN, COMPARTMENT DRAIN, POLYPROP
SEE TABLE I		16	18	101305	PISTON, RACK
SEE TABLE I		15	4	414232	RACK, PAN SLIDE, 18"
SEE TABLE I		14	4	00784	LEG, BULLET
SEE TABLE I		13	2	14885	NUT, HEX, 1/4-20 ELASTIC LOCK
SEE TABLE I		12	2	104193	INSULATION, BODY, OUT
SEE TABLE I		11	1	106837	TIMER ASSY, ELECTRIC CONTROL, GRAY LABEL
SEE TABLE I		10	1	106884	TIMER ASSY, ON/OFF CONTROL, BLUE LABEL
SEE TABLE I		9	1	107050	TIMER ASSY, MECH. CONTROL, BLUE LABEL
SEE TABLE I		8	1	106959	TIMER ASSY, POWER SWITCH, GRAY LABEL
SEE TABLE I		7	1	106876	PANEL ASSEMBLY, POWER SWITCH, GRAY LABEL
SEE TABLE I		6	1	106703	PANEL ASSEMBLY, POWER SWITCH, BLUE LABEL
SEE TABLE I		5	1	103941	CAVITY WELD ASSY, STEAMCRAFT 10
SEE TABLE I		4	4	104042	HINGE, SNAP, 6/8
SEE TABLE I		3	2	1040431	HINGE ASSY, WELD, LOWER
SEE TABLE I		2	2	1040732	HINGE ASSY, WELD, UPPER
SEE TABLE I		1	4	104077	PIN, HINGE
SEE TABLE I		0	6	23110	WASHER, FLAT 1/4 ID X 3/8 OD, 6/8
SEE TABLE I		0	5	19170	SCREW, HEX HD, 1/4-20 X 3/8 6/8
SEE TABLE I		0	4	14818	NUT, HEX 1/4-20 5/8
SEE TABLE I		0	3	1065832	DOOR, OUTER ASSY, H.L. W/DOOR W/ACTUATOR
SEE TABLE I		0	3	106583	DOOR, OUTER ASSY, H.L. W/DOOR
SEE TABLE I		0	2	104207	DOOR, INNER ASSY, H.L.
SEE TABLE I		0	1	104208	DOOR, OUTER ASSY, H.L. W/ACTUATOR
SEE TABLE I		0	1	104209	DOOR, OUTER ASSY, H.L.

TOLERANCES (EXCEPT AS NOTED)	CLEVELAND RANGE INC.	
DECIMAL ± N/A	SCALE 1/8"	DRAWN BY DUTCHMAN APPROVED BY
ANGULAR ± N/A	TITLE FINAL ASSY., STEAMCRAFT POWER 10, H.L. GAS, VERTICAL PRESSURE BOILER	
CK	DATE 03-01-94	DRAWING NO. C - 106697 PAGE 1 REV. OF

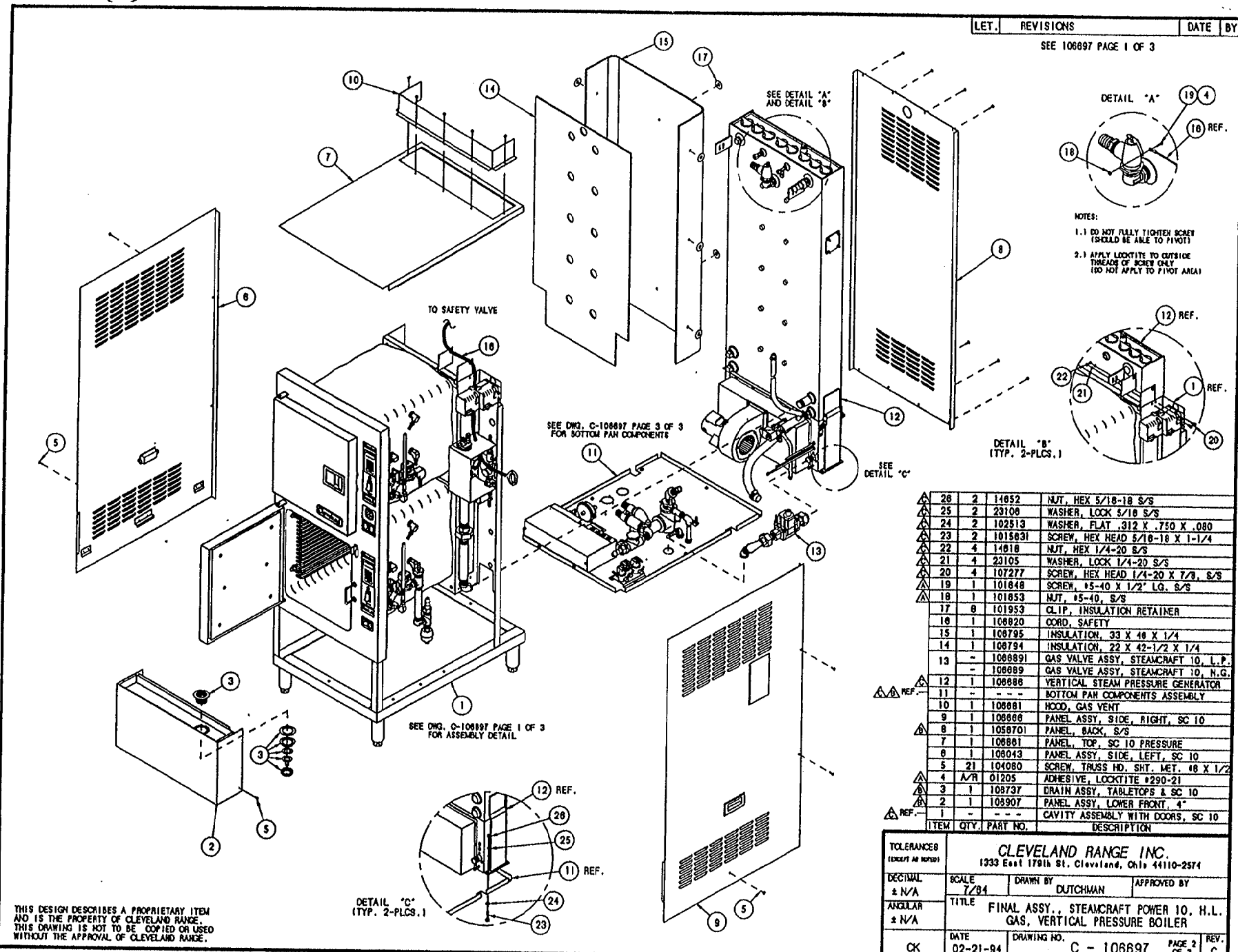

NOTES:
 1.1 DO NOT FULLY TIGHTEN SCREW (SHOULD BE ABLE TO PIVOT)
 2.1 APPLY LOCKTITE TO OUTSIDE TREAD OF SCREW ONLY (DO NOT APPLY TO PIVOT AREA)

28	2	14852	NUT, HEX 5/16-18 S/S
25	2	23106	WASHER, LOCK 5/16 S/S
24	2	102513	WASHER, FLAT .312 X .750 X .080
23	2	1015631	SCREW, HEX HEAD 5/16-18 X 1-1/4
22	4	14818	NUT, HEX 1/4-20 S/S
21	4	23105	WASHER, LOCK 1/4-20 S/S
20	4	107277	SCREW, HEX HEAD 1/4-20 X 7/8, S/S
19	1	101848	SCREW, #5-40 X 1/2" LG. S/S
18	1	101853	NUT, #5-40, S/S
17	8	101953	CLIP, INSULATION RETAINER
16	1	108820	CORD, SAFETY
15	1	108795	INSULATION, 33 X 48 X 1/4
14	1	108794	INSULATION, 22 X 42-1/2 X 1/4
13	-	1088891	GAS VALVE ASSY, STEAMCRAFT 10, L.P.
13	-	108889	GAS VALVE ASSY, STEAMCRAFT 10, N.G.
12	1	108888	VERTICAL STEAM PRESSURE GENERATOR
11	-	-	BOTTOM PAN COMPONENTS ASSEMBLY
10	1	108881	HOOD, GAS VENT
9	1	108868	PANEL ASSY, SIDE, RIGHT, SC 10
8	1	1058701	PANEL, BACK, S/S
7	1	108861	PANEL, TOP, SC 10 PRESSURE
6	1	106043	PANEL ASSY, SIDE, LEFT, SC 10
5	21	104080	SCREW, TRUSS HD. SHT. MET. #8 X 1/2
4	A/R	01205	ADHESIVE, LOCKTITE #290-21
3	1	108737	DRAIN ASSY, TABLETOPS & SC 10
2	1	108907	PANEL ASSY, LOWER FRONT, 4"
1	-	-	CAVITY ASSEMBLY WITH DOORS, SC 10
ITEM	QTY.	PART NO.	DESCRIPTION

TOLERANCES (EXCEPT AS NOTED)			
DECIMAL ± N/A	SCALE 1/8"	DRAWN BY DUTCHMAN	APPROVED BY
ANGULAR ± N/A	TITLE	FINAL ASSY., STEAMCRAFT POWER 10, H.L. GAS, VERTICAL PRESSURE BOILER	
CK	DATE 02-21-94	DRAWING NO. C - 106897	PAGE 2 OF 3 REV. C

THIS DESIGN DESCRIBES A PROPRIETARY ITEM AND IS THE PROPERTY OF CLEVELAND RANGE. THIS DRAWING IS NOT TO BE COPIED OR USED WITHOUT THE APPROVAL OF CLEVELAND RANGE.

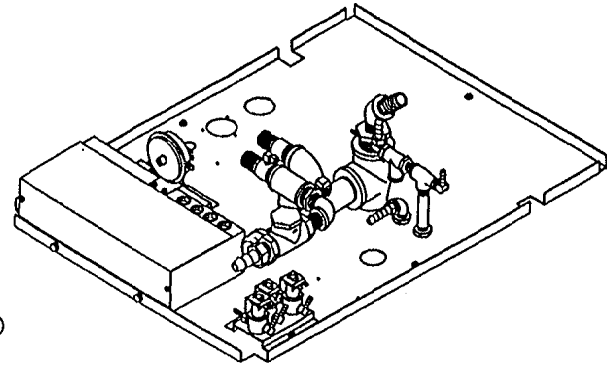
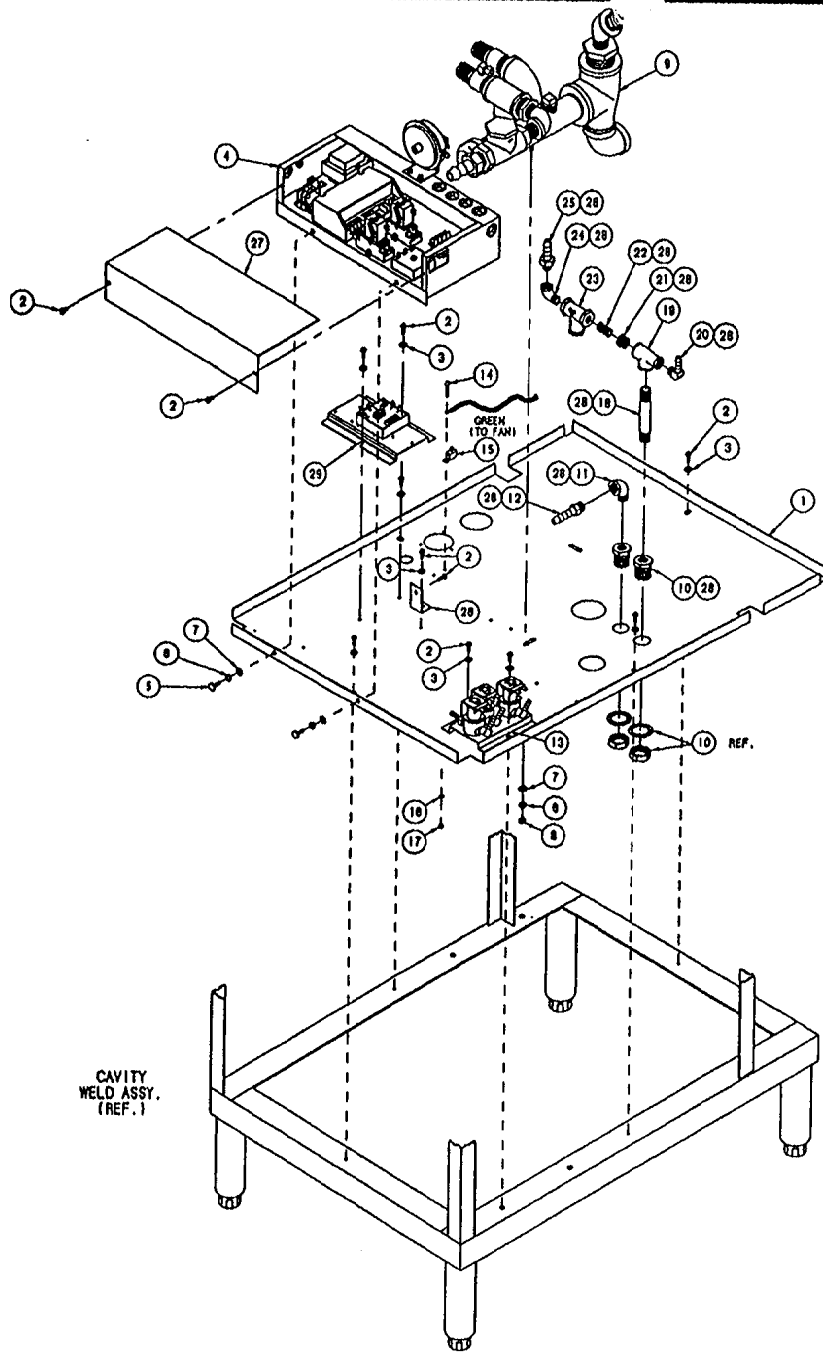

ITEM	QTY.	PART NO.	DESCRIPTION
29	1	107072	CLEAN LIGHT TIMER PLATE, SC POWER 10
28	A/R	00934	ADHESIVE, RECTORSEAL
27	1	106809	COVER, ELECTRIC BOX
26	1	105955	BRACKET, CONTROL MOUNT, GAS
25	1	104048	FITTING, HOSE 1/4 MPT X 1/2 H. STR.
24	1	05229	ELBOW, STREET 1/4 X 90°
23	1	19870	STRAINER, 1/4
22	1	14304	NIPPLE, 1/4 X CLOSE
21	1	02594	BUSHING, 3/8 X 1/4
20	1	105788	FITTING, HOSE 1/4 MPT X 1/4 H. 90°
19	1	100527	TEE, 3/8 X 1/4 X 3/8, BRASS
18	1	14320	NIPPLE, 3/8 X 4, BRASS
17	1	14659	NUT, HEX 10-24, 8/8
16	1	23114	WASHER, LOCK, INT. TOOTH #10
15	1	20304	LUG, GROUND, SOLDERLESS
14	1	19287	SCREW, RD HD SLTD, #10-24 X 1/2
13	1	105981	WATER INLET ASSY.
12	1	100748	FITTING, HOSE, 3/8 NPT X 1/2 H. STR.
11	1	05280	ELBOW, STREET, 3/8 X 90°, BRASS
10	2	105794	FITTING, BULKHEAD, 3/8 NPT, BRASS
9	1	106868	DRAIN MANIFOLD ASSY., SC10, GAS, VP8
8	1	14618	NUT, HEX. 1/4-20, 5/8
7	3	23118	WASHER, FLAT, 1/4, 5/8
6	3	23105	WASHER, SPLIT LOCK, 1/4, 5/8
5	2	19170	SCREW, HEX HD. 1/4-20 X 5/8, 5/8
4	1	106785	ELECTRIC BOX ASSY., SC 10, PRESSURE
3	9	101655	WASHER, FLAT #10, 5/8
2	12	106123	SCREW, TORX/SLOT 10-32 X 1/2
1	1	105687	PAN, BOTTOM, STEAMCRAFT 10

CAVITY WELD ASSY. (REF.)

THIS DESIGN DESCRIBES A PROPRIETARY ITEM AND IS THE PROPERTY OF CLEVELAND RANGE. THIS DRAWING IS NOT TO BE COPIED OR USED WITHOUT THE APPROVAL OF CLEVELAND RANGE.

TOLERANCES (UNLESS AS NOTED)		CLEVELAND RANGE INC. 1333 East 179th St., Cleveland, Ohio 44110-2574	
DECIMAL ± .030	SCALE 3/16" = 1"		
ANGULAR ± 1°	TITLE FINAL ASSY., STEAMCRAFT POWER 10, H.L. GAS, VERTICAL PRESSURE BOILER	DATE 02-21-94	DRAWING NO. C - 106897
CK	PAGE 3 OF 3	REV. C	

NOTES:

1.1 RELATIVE POSITION OF OBJECTS ARE NOT REPRESENTATIVE OF INSTALLED LOCATIONS.

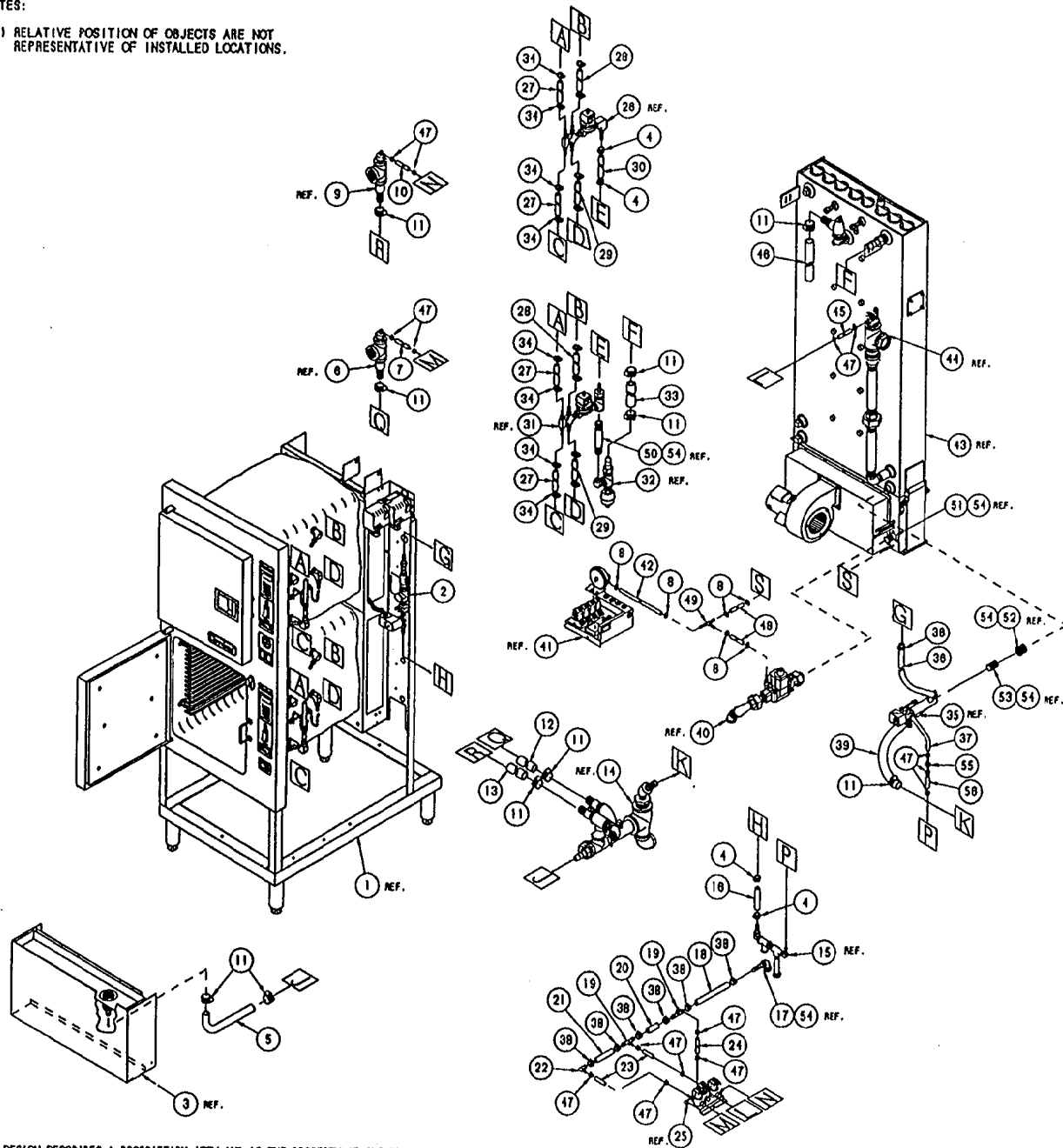

LET.	REVISIONS	BY
A	SEE E.O. #C-2688	07-05-94 PJC
B	SEE E.O. #C-2682	12-05-94 PJC

ITEM	QTY	PART NO.	DESCRIPTION
56	1	1058500200	HOSE, NT-80 1/4 X 1/2 X 2' LG.
55	1	107032	CHECK VALVE, PLASTIC DIAPHRAGM
54	A/B	00934	SEALANT, RECTORSEAL
53	-	14343	RIPPLE, 3/4 X CLOSE, BLACK
52	-	02598	BUSHING, HEX, 1 X 3/4
51	-	106840	MANIFOLD ASSY, GAS 250,000 BTU BOILER
50	-	14358	RIPPLE, 3/4" X 8" LG.
49	1	105791	FITTING, HOSE, TEE, 1/4"
48	2	1043791000	HOSE, SILICONE 1/4 ID X 1/2 OD X 10' LG
47	10	106520	CLAMP, WORM DRIVE 3/16 TO 5/18 DIA.
46	1	1054698000	HOSE, EPDM, BLACK, 1" ID X 80" LG.
45	1	1058504800	HOSE, NT-80, 1/4 ID X 1/2 OD X 48" LG
44	-	106690	FLOAT ASSEMBLY
43	-	-	GENERATOR ASSEMBLY, SC 10 GAS PRESSURE
42	1	1043792200	HOSE, SILICONE 1/4 ID X 1/2 OD X 22" LG
41	-	105902	ELECTRIC BOX ASSEMBLY
40	-	-	GAS VALVE ASSY.
39	1	1054690950	HOSE, EPDM, BLACK, 1" ID X 8.5" LG.
38	8	106219	CLAMP, WORM DRIVE 1/4 TO 25/32 DIA.
37	1	1058500800	HOSE, NT-80, 1/4 ID X 1/2 OD X 8" LG
36	1	1058494100	HOSE, NT-80 1/2 ID X 3/4 OD X 44" LG
35	-	106687	VALVE ASSY, DRAIN
34	18	107093	CLAMP, HOSE, METAL TENSION BAND 3/8"
33	1	085055150	HOSE, DARIPREEN 3/4 ID X 51,500" LG.
32	-	106693	STEAM OUTLET ASSY.
31	-	106892	STEAM INLET ASSY, LOWER COMPARTMENT
30	1	085041950	HOSE, DARIPREEN 1/2 ID X 3/4 OD X 19,500
29	2	1052791050	HOSE, SILICONE 3/8 ID X 10,500" LG
28	2	1052791200	HOSE, SILICONE 3/8 ID X 12" LG
27	4	1052790475	HOSE, SILICONE 3/8 ID X 4,750" LG
26	-	106691	STEAM INLET ASSY, UPPER COMPARTMENT
25	-	105981	WATER INLET ASSY TO FLOAT & COMPTS.
24	1	1058501100	HOSE, NT-80, 1/4 ID X 1/2 OD X 11" LG
23	2	1058500200	HOSE, NT-80, 1/4 ID X 1/2 OD X 2" LG
22	1	105792	FITTING, ELBOW 90°, 1/4 H X 1/2 H
21	1	1058490300	HOSE, NT-80 1/2 ID X 3/4 OD X 3,000 LG
20	1	1058490200	HOSE, NT-80 1/2 ID X 3/4 OD X 2,000 LG
19	2	105780	FITTING, TEE 1/2 H X 1/2 H X 1/4 H
18	1	1058490850	HOSE, NT-80 1/2 ID X 3/4 OD X 8,500 LG
17	-	-	WATER INLET ASSY.
16	1	1058492800	HOSE, NT-80 1/2 ID X 3/4 OD X 26" LG.
15	-	-	WATER INLET TO DRAIN VALVE & WATER TREE
14	-	106688	DRAIN MANIFOLD ASSY, SC10 GAS PRESSURE
13	1	1054694100	HOSE, EPDM, BLACK, 1" ID X 41" LG.
12	1	1054692100	HOSE, EPDM, BLACK, 1" ID X 21" LG.
11	11	03204	CLAMP, WORM DRIVE .812" TO 1.500" DIA.
10	1	1058504800	HOSE, NT-80, 1/4 ID X 1/2 OD X 48" LG
9	1	-	COMPARTMENT DRAIN ASSY, SC 10, UPPER
8	6	104393	CLAMP, NYLON, 1/2" OD HOSE
7	1	1058503100	HOSE, NT-80, 1/4 ID X 1/2 OD X 31" LG
6	1	-	COMPARTMENT DRAIN ASSY, SC 10, LOWER
5	1	107010	HOSE, TRAY DRAIN, 3/4" I.D. BLACK EPDM
4	4	03208	CLAMP, WORM DRIVE, 1/2-29/32" DIA.
3	-	-	PANEL ASSY, LOWER FRONT, SC 10
2	-	106702	WATER FEED ASSY.
1	-	-	CAVITY ASSY. WITH DOORS, SC 10

TOLERANCES (EXCEPT AS NOTED)		CLEVELAND RANGE INC. 1333 East 179th St. Cleveland, Ohio 44110-2574	
DECIMAL ± N/A	SCALE N/A	DRAWN BY DUTCHMAN	APPROVED BY
ANGULAR ± N/A	TITLE HOSE DETAIL, STEAMCRAFT POWER 10, H.L. GAS, VERTICAL PRESSURE BOILER		
DATE 02-28-94	DRAWING NO. C - 106757	REV. B	

THIS DESIGN DESCRIBES A PROPRIETARY ITEM AND IS THE PROPERTY OF CLEVELAND RANGE. THIS DRAWING IS NOT TO BE COPIED OR USED WITHOUT THE APPROVAL OF CLEVELAND RANGE.

LET.	REVISIONS	DATE	BY
-	NEW RELEASE PER E.O. 128735	12-08-94	PJO

REMOVE PLUGS BEFORE
INSTALLING BOILER KIT

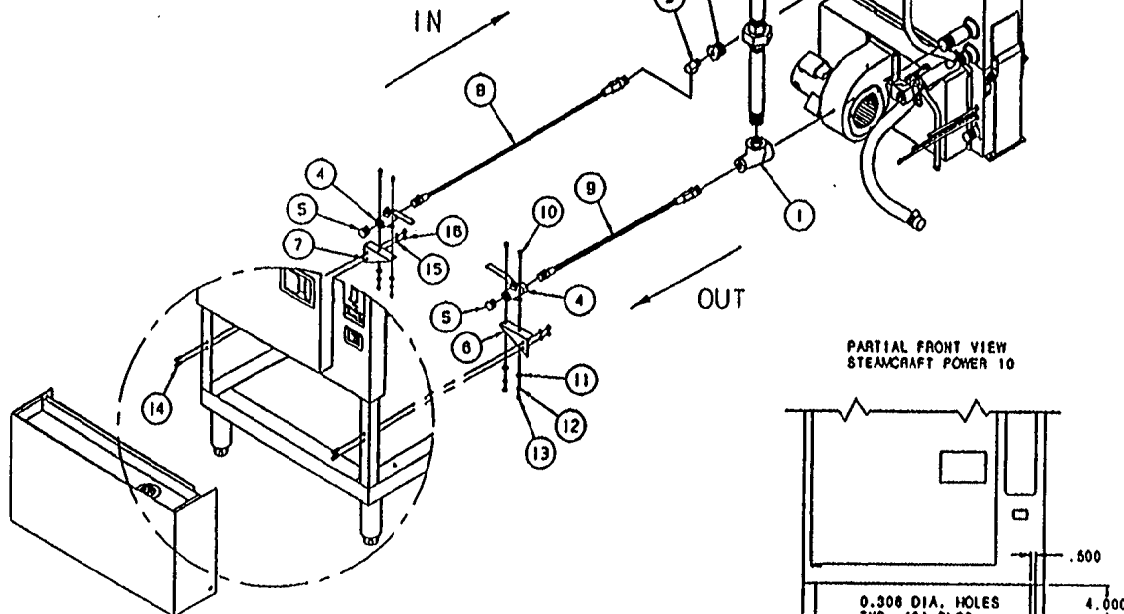
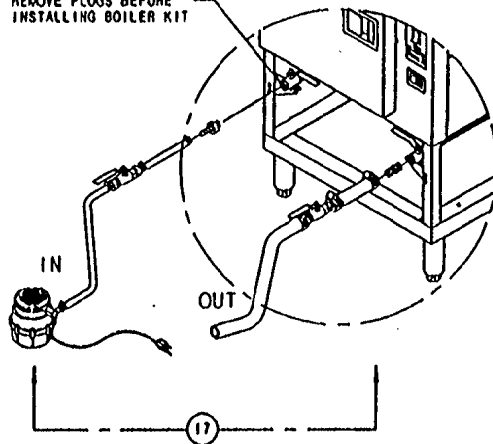

PARTIAL FRONT VIEW
STEAMCRAFT POWER 10

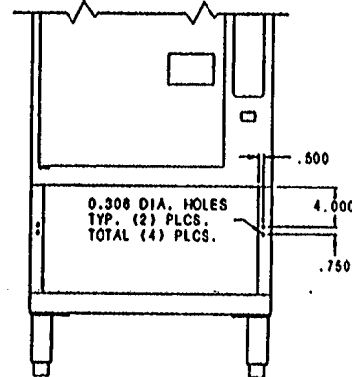

DESCALER KIT
DRILLING DIAGRAM

DESIGN DESCRIBES A PROPRIETARY ITEM
THE PROPERTY OF CLEVELAND RANGE.
DRAWING IS NOT TO BE COPIED OR USED
WITHOUT THE APPROVAL OF CLEVELAND RANGE.

ITEM	QTY	PART NO.	DESCRIPTION
17	1	107142	KIT, BOILER, DESCALER, PORTABLE
16	4	14818	NUT, HEX 1/4-20
15	4	23105	WASHER, LOCK 1/4"
14	4	18170	SCREW, HEX HEAD 1/4-20 X .625" LG.
13	4	14848	NUT, HEX #10-32
12	4	23113	WASHER, LOCK #10
11	4	101866	WASHER, FLAT #10
10	4	108124	SCREW, PAN HEAD #10-32 X 1" LG.
9	1	107223	HOSE ASSY, TEFLON, S/S BRAIDED 1/2"
8	1	107222	HOSE ASSY, TEFLON, S/S BRAIDED 3/8"
7	1	1072131	BRACKET, BALL VALVE MOUNTING, L.H.
6	1	107213	BRACKET, BALL VALVE MOUNTING, R.H.
5	2	16808	PLUG, HEX HEAD 1/2" PIPE
4	2	107221	BALL VALVE W/ MOUNTING TABS
3	1	05280	ELBOW, STREET 3/8" BRASS
2	1	02828	BUSHING, REDUCER 1" X 3/8" BRASS
1	1	100223	TEE, 1" X 1/2" X 1", BLACK
ITEM QTY PART NO.			DESCRIPTION
TOLERANCES (EXCEPT AS NOTED)			CLEVELAND RANGE INC. 1333 East 178th St., Cleveland, Ohio 44110-2571
DECIMAL # N/A	SCALE 1/8"	DRAWN BY DUTCHMAN	APPROVED BY
ANGULAR # N/A	TITLE DESCALER KIT STEAMCRAFT POWER		
CK	DATE 10-17-94	DRAWING NO. C-10114	REV.

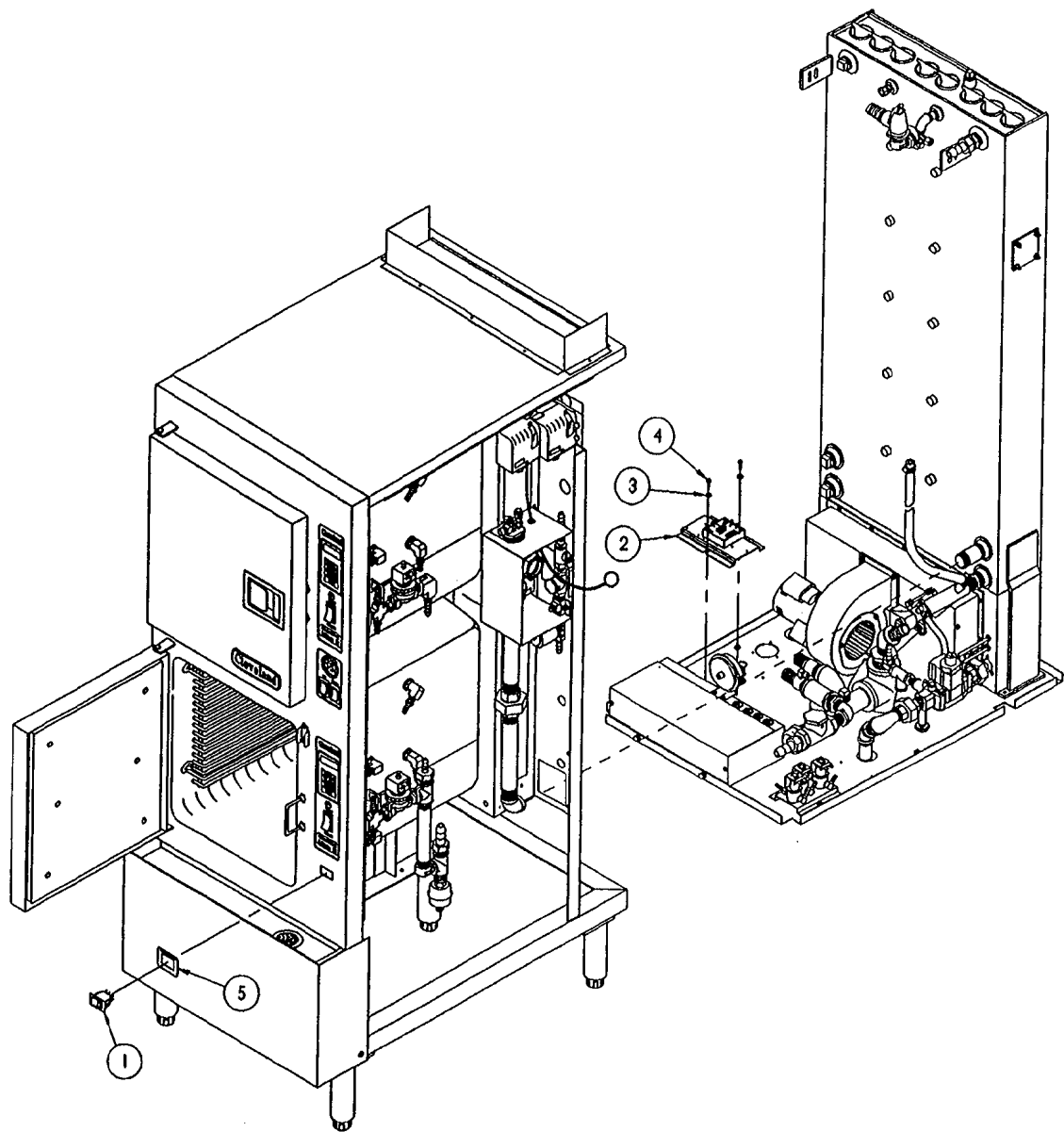

THIS DESIGN DESCRIBES A PROPRIETARY ITEM AND IS THE PROPERTY OF CLEVELAND RANGE. THIS DRAWING IS NOT TO BE COPIED OR USED WITHOUT THE APPROVAL OF CLEVELAND RANGE.

5	1	107011	LABEL, CLEAN LIGHT
4	2	108123	SCREW, TORX/SLOT 10-32 X 1/2
3	2	101855	WASHER, FLAT #10 S/S
2	1	107072	CLEAN LIGHT TIMER PLATE, SC POWER 10
1	1	19994	SWITCH, ROCKER, SPST
ITEM	QTY.	PART NO.	DESCRIPTION

TOLERANCES (EXCEPT AS NOTED)			
CLEVELAND RANGE INC. 1333 East 179th St. Cleveland, Ohio 44110-2574			
DECIMAL ± N/A	SCALE 5/32±1	DRAWN BY DUTCHMAN	APPROVED BY
ANGULAR ± N/A	TITLE INSTRUCTION, INSTALLATION POWER 10 GAS CLEAN LIGHT AND TIMER PLATE		
CK	DATE 09-15-94	DRAWING NO. C - 260ALE	REV. -

STEAMCRAFT
POWER 10 ONLY

LET.	REVISIONS	DATE	BY
------	-----------	------	----

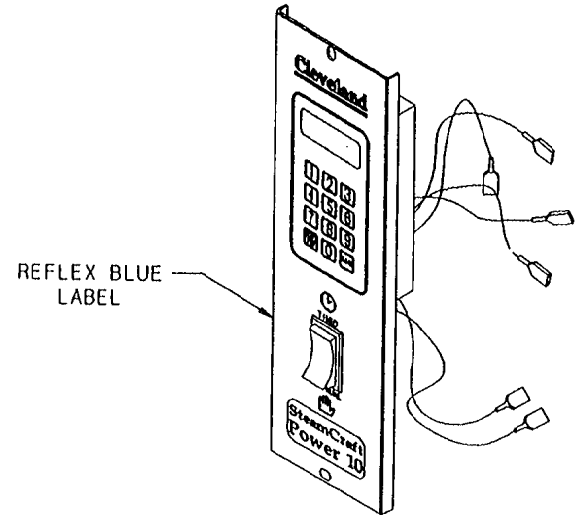
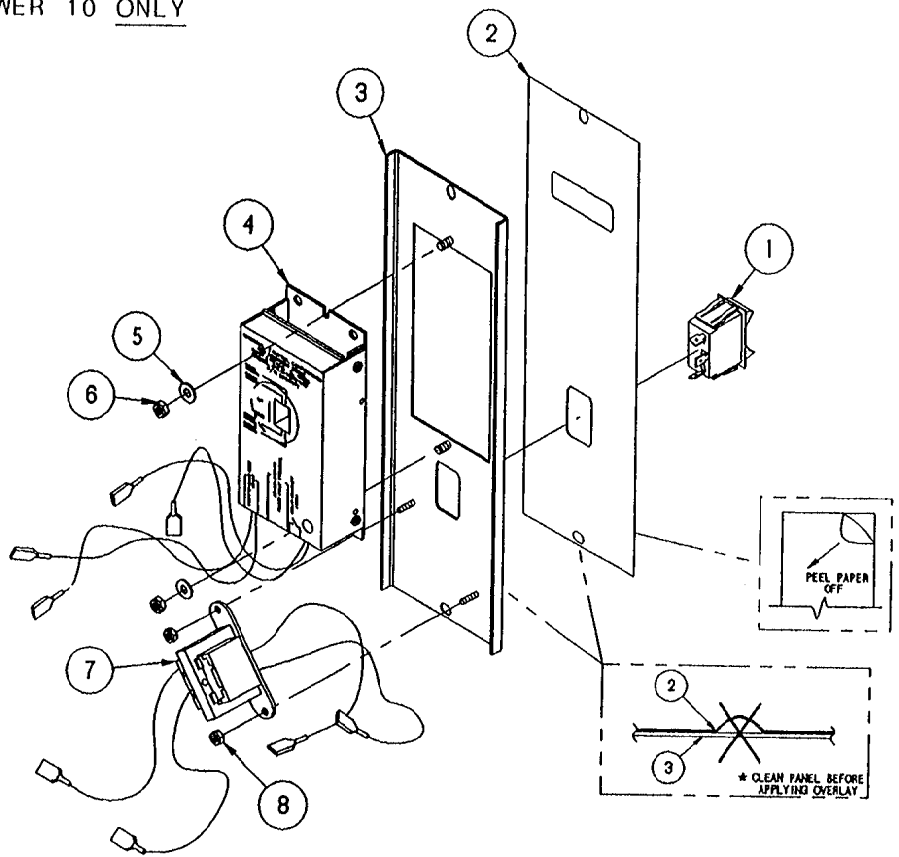

ITEM	QTY.	PART NO.	DESCRIPTION
8	2	104223	NUT, HEX, #6-32, ELASTIC LOCK
7	1	104390	TRANSFORMER ASSEMBLY
6	2	14692	NUT, HEX, #10-24, ELASTIC LOCK
5	2	101655	WASHER, FLAT, #10, S/S
4	1	104389	TIMER ASSEMBLY, NCC
3	1	104704	PANEL, WELDMENT, ELEC TIMER
2	1	1084541	LABEL, CONTROL PANEL POWER 10
1	1	104224	SWITCH, ROCKER, SPDT

THIS DESIGN DESCRIBES A PROPRIETARY ITEM AND IS THE PROPERTY OF CLEVELAND RANGE. THIS DRAWING IS NOT TO BE COPIED OR USED WITHOUT THE APPROVAL OF CLEVELAND RANGE.

TOLERANCES (EXCEPT AS NOTED)	CLEVELAND RANGE INC. 1333 East 179th St. Cleveland, Ohio 44110-2574		
DECIMAL ± N/A	SCALE 3/8=1	DRAWN BY DUTCHMAN	APPROVED BY
ANGULAR ± N/A	TITLE CONTROL PANEL, NCC TIMER STEAMCRAFT POWER 10		
CK	DATE 05-06-94	DRAWING NO. B - 106999	REV. -

BOSTON CHICKEN ONLY
POWER 10 AND CONVECTION

LET.	REVISIONS	DATE	BY
------	-----------	------	----

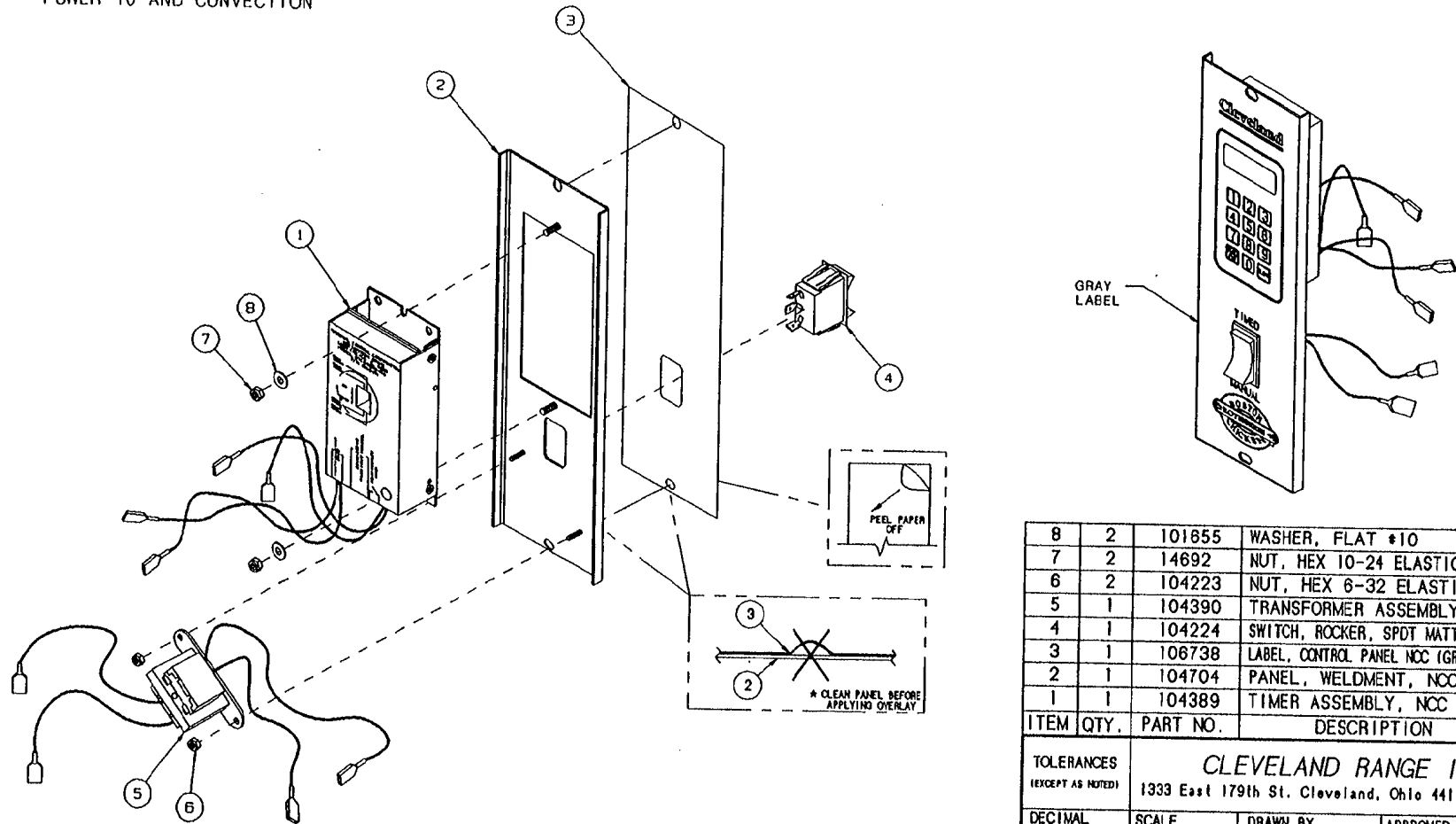

ITEM	QTY.	PART NO.	DESCRIPTION
8	2	101855	WASHER, FLAT #10
7	2	14692	NUT, HEX 10-24 ELASTIC LOCK
6	2	104223	NUT, HEX 6-32 ELASTIC LOCK
5	1	104390	TRANSFORMER ASSEMBLY
4	1	104224	SWITCH, ROCKER, SPOT MATTE FINISH
3	1	106738	LABEL, CONTROL PANEL NCC (GRAY COLOR)
2	1	104704	PANEL, WELDMENT, NCC
1	1	104389	TIMER ASSEMBLY, NCC

THIS DESIGN DESCRIBES A PROPRIETARY ITEM
AND IS THE PROPERTY OF CLEVELAND RANGE.
THIS DRAWING IS NOT TO BE COPIED OR USED
WITHOUT THE APPROVAL OF CLEVELAND RANGE.

TOLERANCES (EXCEPT AS NOTED)		CLEVELAND RANGE INC. 1333 East 179th St. Cleveland, Ohio 44110-2574	
DECIMAL ± .030	SCALE 3/8=1	DRAWN BY DUTCHMAN	APPROVED BY
ANGULAR ± 1°	TITLE TIMER ASSEMBLY, NCC BOSTON CHICKEN		
CK	DATE 05-06-94	DRAWING NO. B - 106827	REV. -

STEAMCRAFT
POWER 10 ONLY

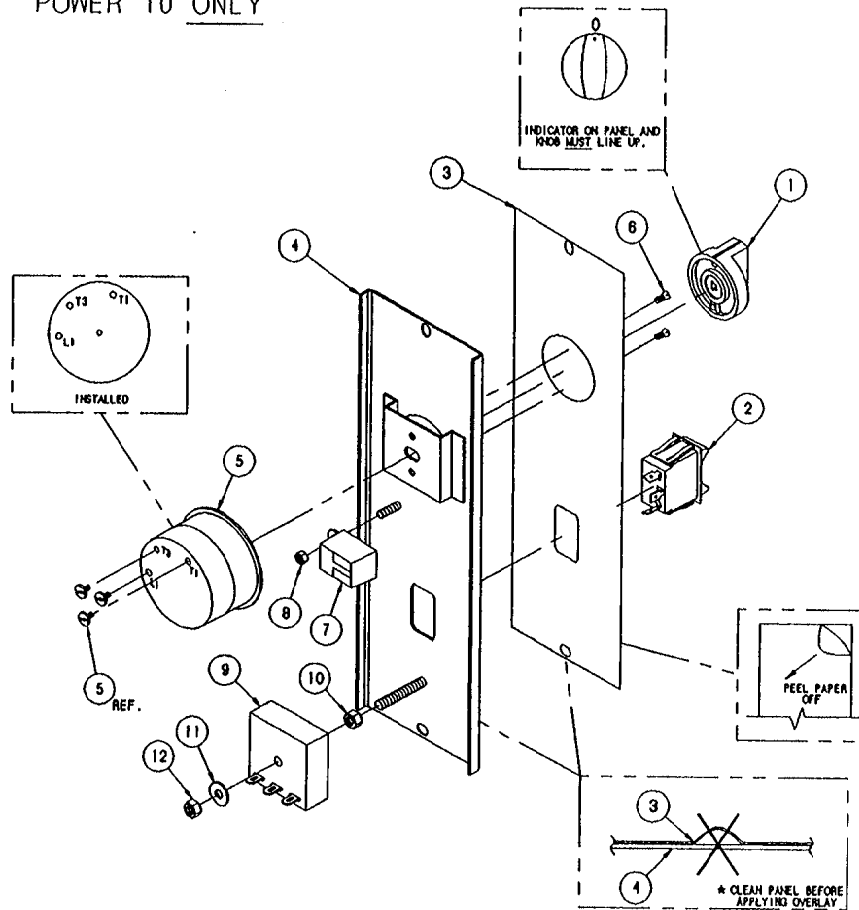

THIS DESIGN DESCRIBES A PROPRIETARY ITEM AND IS THE PROPERTY OF CLEVELAND RANGE. THIS DRAWING IS NOT TO BE COPIED OR USED WITHOUT THE APPROVAL OF CLEVELAND RANGE.

LET.	REVISIONS	DATE	BY
------	-----------	------	----

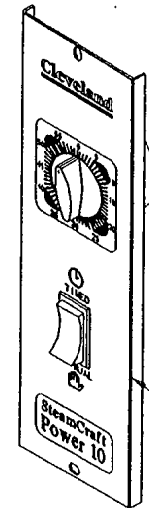

REFLEX BLUE LABEL

ITEM	QTY.	PART NO.	DESCRIPTION
12	1	101873	NUT, HEX, 1/4-20, ELASTIC LOCK
11	1	23116	WASHER, FLAT, 1/4, S/S
10	1	14617	NUT, HEX, 1/4-20, BLACK OXIDE
9	1	20477	TIMER, SOLID STATE, 3 SEC
8	1	14692	NUT, HEX, 10-24, ELASTIC LOCK
7	1	41350	BUZZER ASSY, w/ TERMINALS
6	2	19201	SCREW, PAN HD, 5-40 x .250
5	1	20476	TIMER, 60 MIN, MECH. SWITCH
4	1	104958	PANEL, WELDMENT, MECH. TIMER
3	1	1065371	LABEL, CONTROL PANEL, MECH.
2	1	104224	SWITCH, ROCKER, SPDT
1	1	11307	KNOB, TIMER

TOLERANCES (EXCEPT AS NOTED)		CLEVELAND RANGE INC. 1333 East 179th St. Cleveland, Ohio 44110-2574	
DECIMAL ± N/A	SCALE 3/8=1	DRAWN BY DUTCHMAN	APPROVED BY
ANGULAR ± N/A	TITLE CONTROL PANEL, MECHANICAL TIMER STEAMCRAFT POWER 10		
CK	DATE 05-06-94	DRAWING NO. B - 107000	REV. -

LET.	REVISIONS	DATE	BY
------	-----------	------	----

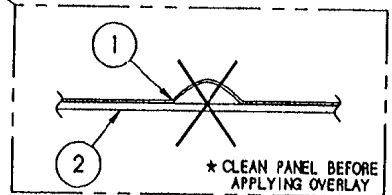
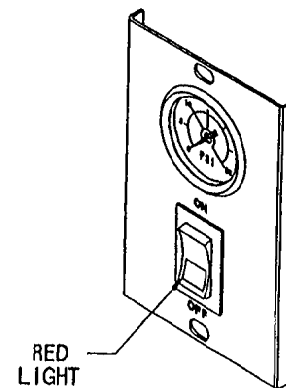
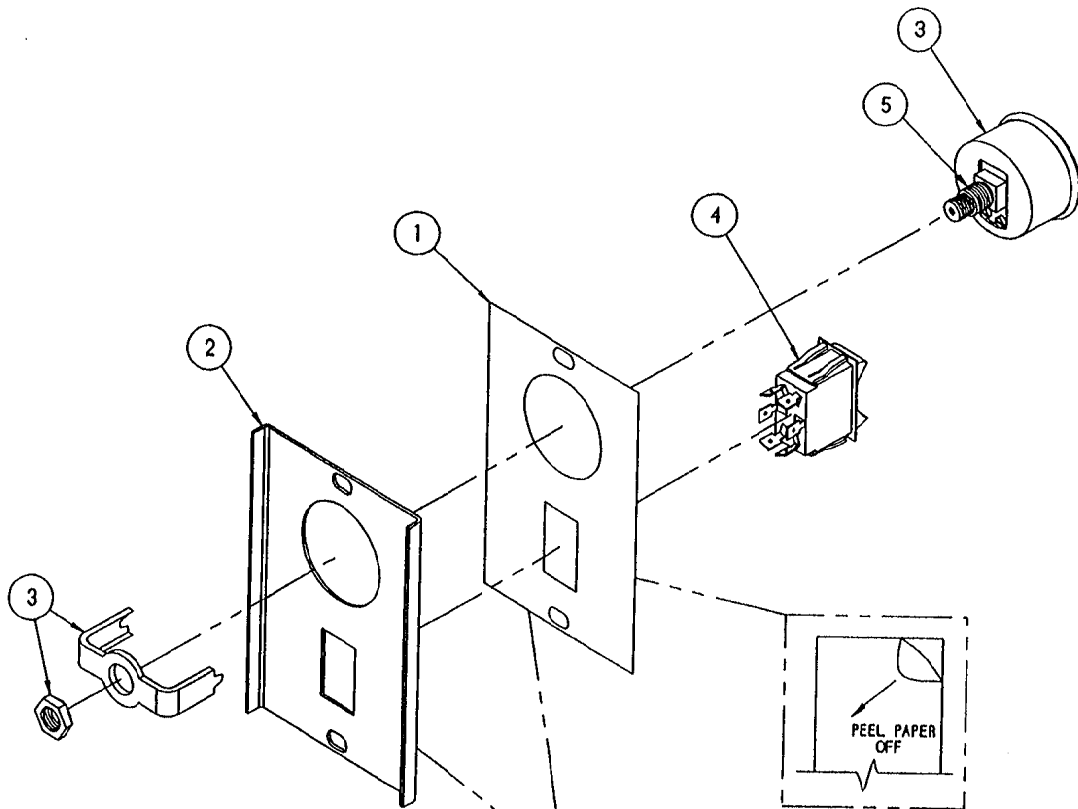

THIS DESIGN DESCRIBES A PROPRIETARY ITEM AND IS THE PROPERTY OF CLEVELAND RANGE. THIS DRAWING IS NOT TO BE COPIED OR USED WITHOUT THE APPROVAL OF CLEVELAND RANGE.

ITEM	QTY.	PART NO.	DESCRIPTION
5	A/R	00934	ADHESIVE, RECTORSEAL
4	1	19993	SWITCH, ROCKER, DPDT, ON/OFF
3	1	07168	GAUGE, PRESSURE, 10 PSI
2	1	1067221	PANEL, CONTROL, WELD ASSY
1	1	106695	LABEL, CONTROL PANEL, POWER
			DESCRIPTION
TOLERANCES (EXCEPT AS NOTED)		CLEVELAND RANGE INC. 1333 East 179th St. Cleveland, Ohio 44110-2574	
DECIMAL ± N/A	SCALE 1/2=1	DRAWN BY DUTCHMAN	APPROVED BY
ANGULAR ± N/A	TITLE PANEL ASSEMBLY POWER SWITCH SC 10, DIRECT CONNECT		
CK	DATE 10-15-93	DRAWING NO. B - 10094	REV. -

LET	REVISIONS	DATE	BY
A	ADDED DETAIL PER E.O. #C-2702	08-09-94	PJD

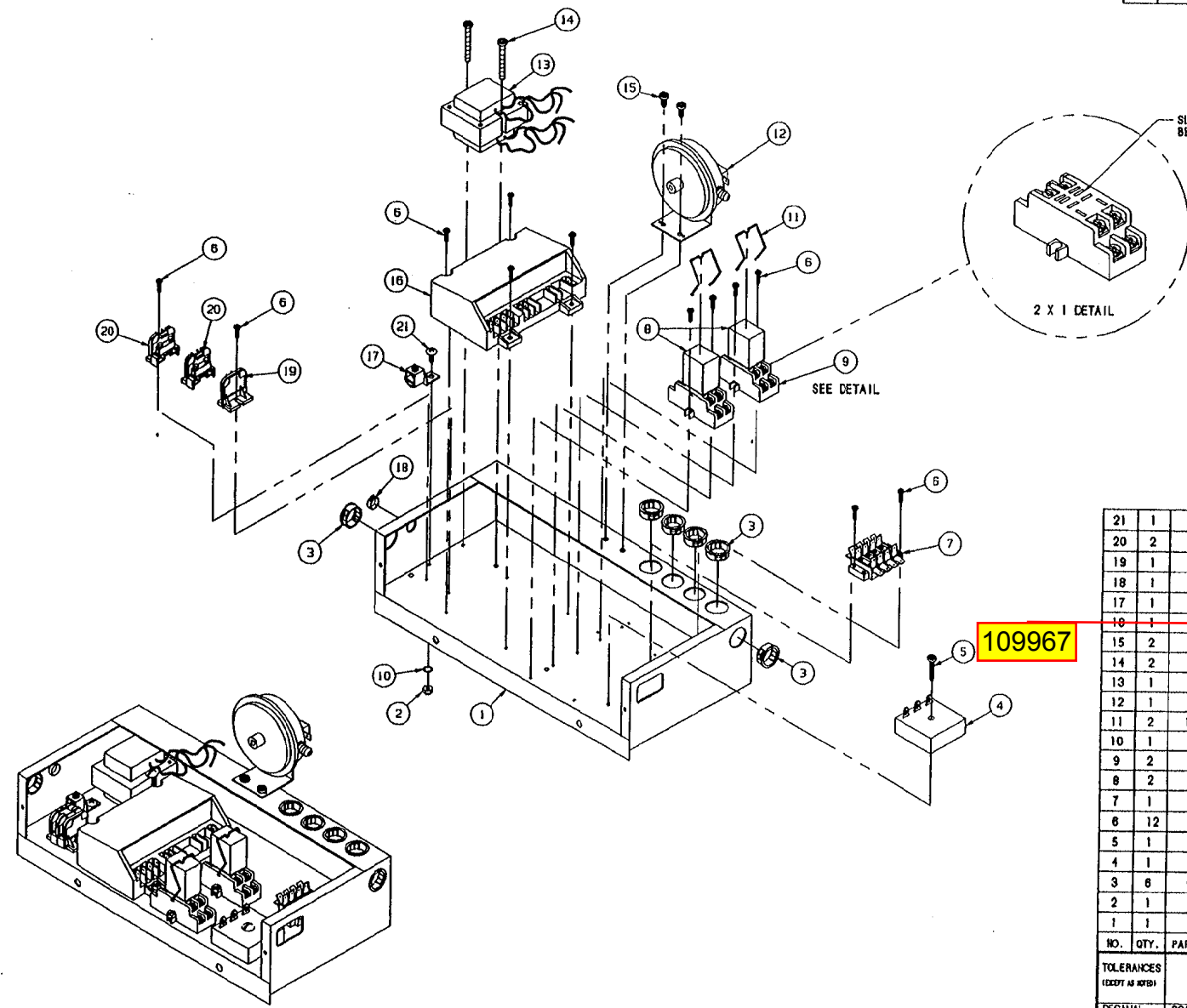

NO.	QTY.	PART NO.	DESCRIPTION
21	1	19287	SCREW, PAN HEAD, 10-24 X 1/2
20	2	20301	TERMINAL SECTION, MARATHON
19	1	20302	TERMINAL, END SECTION, MARATHON
18	1	02818	BUSHING, INSULATOR, HEYCO
17	1	20304	GROUND LUG
10	1	10599	SPARK IGNITION CONTROL MODULE
15	2	106123	SCREW, SLTD TORX, #10-32 X 1/2
14	2	106125	SCREW, SLTD TORX, #10-32 X 1.75
13	1	20528	TRANSFORMER, 24 VOLT
12	1	105788	SWITCH, AIR PROVER
11	2	105044	CLIP, WIRE, RELAY
10	1	23114	WASHER, INTERNAL TOOTH, 10-32
9	2	03525	SOCKET, RELAY
8	2	03524	RELAY, 120V
7	1	105990	TERMINAL BLOCK ASSY, 4 POLE
6	12	106127	SCREW, SLTD TORX, #6-32 X 1/2
5	1	106124	SCREW, SLTD TORX, #10-32 X 1
4	1	20478	INTERVAL TIMER, 180 SEC.
3	6	02800	BUSHING, INSULATOR, HEYCO
2	1	14849	NUT, HEX
1	1	105517	BOX, ELECTRIC, WELDMENT

TOLERANCES (EXCEPT AS NOTED)			
CLEVELAND RANGE INC. 1333 East 179th St. Cleveland, Ohio 44110-2574			
DECIMAL ± N/A	SCALE 3/8"=1	DRAWN BY D. OGDSON	APPROVED BY -
ANGULAR ± N/A	TITLE ELECTRIC BOX ASSEMBLY STEAMCRAFT 10, PRESSURE		
DATE 02-10-94	DRAWING NO. C - 108785	REV. A	

THIS DESIGN DESCRIBES A PROPRIETARY ITEM AND IS THE PROPERTY OF CLEVELAND RANGE. THIS DRAWING IS NOT TO BE COPIED OR USED WITHOUT THE APPROVAL OF CLEVELAND RANGE.

LET	REVISIONS	DATE	BY
-----	-----------	------	----

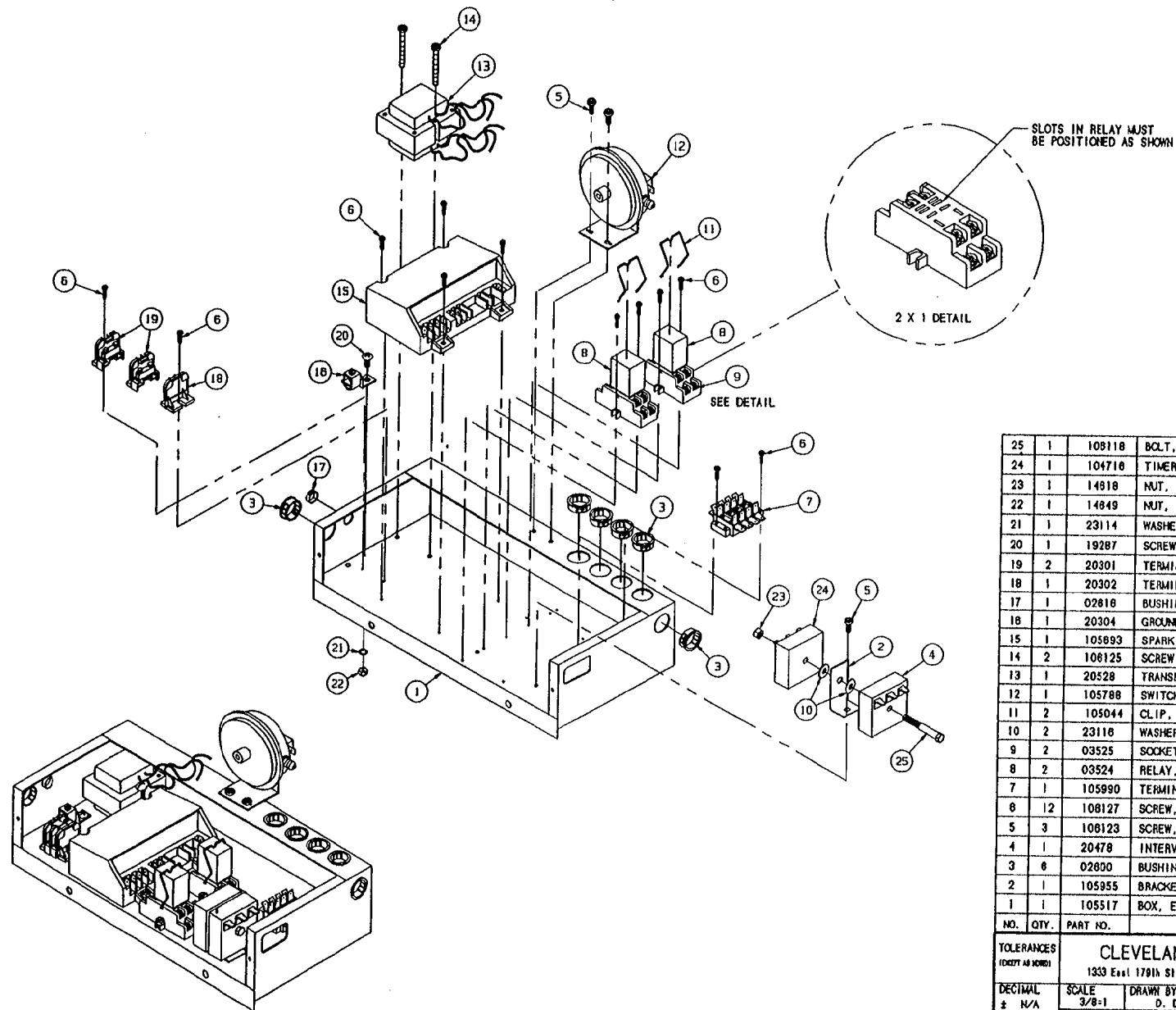

25	1	108118	BOLT, 1/4-20 X 2-1/4, ZINC PLTD
24	1	104710	TIMER, RECYCLING
23	1	14818	MUT. HEX, 1/4-20, FULL FINISH
22	1	14849	MUT, HEX
21	1	23114	WASHER, INTERNAL TOOTH, 10-32
20	1	19287	SCREW, PAN HD, 10-24 X 1/2
19	2	20301	TERMINAL SECTION, MARATHON
18	1	20302	TERMINAL, END SECTION, MARATHON
17	1	02818	BUSHING, INSULATOR, HEYCO
16	1	20304	GROUND LUG
15	1	105893	SPARK IGNITION CONTROL MODULE
14	2	108125	SCREW, SLTD TORX, #10-32 X 1.75
13	1	20528	TRANSFORMER, 24 VOLT
12	1	105788	SWITCH, AIR PROVER
11	2	105044	CLIP, WIRE, RELAY
10	2	23116	WASHER, FLAT, 1/4-20, S/S
9	2	03525	SOCKET, RELAY
8	2	03524	RELAY, 120V
7	1	105990	TERMINAL BLOCK ASSY, 4 POLE
6	12	108127	SCREW, SLTD TORX, #8-32 X 1/2
5	3	108123	SCREW, SLTD TORX, #10-32 X 1/2
4	1	20478	INTERVAL TIMER, 180 SEC.
3	6	02800	BUSHING, INSULATOR, HEYCO
2	1	105955	BRACKET, DUAL TIMER MOUNTING
1	1	105517	BOX, ELECTRIC, WELDMENT
NO.	QTY.	PART NO.	DESCRIPTION

TOLERANCES (UNLESS OTHERWISE SPECIFIED)			
CLEVELAND RANGE INC.			
1333 East 179th St. Cleveland, Ohio 44110-2574			
DECIMAL ± N/A	SCALE 3/8-1	DRAWN BY D. COOSON	APPROVED BY -
ANGULAR ± N/A	TITLE ELECTRIC BOX ASSEMBLY S/C 10 PRESSURE, INTERMITTENT BLOWDOWN		
CK	DATE 02-10-94	DRAWING NO. C - 10878	EV. -

THIS DESIGN DESCRIBES A PROPRIETARY ITEM AND IS THE PROPERTY OF CLEVELAND RANGE. THIS DRAWING IS NOT TO BE COPIED OR USED WITHOUT THE APPROVAL OF CLEVELAND RANGE.

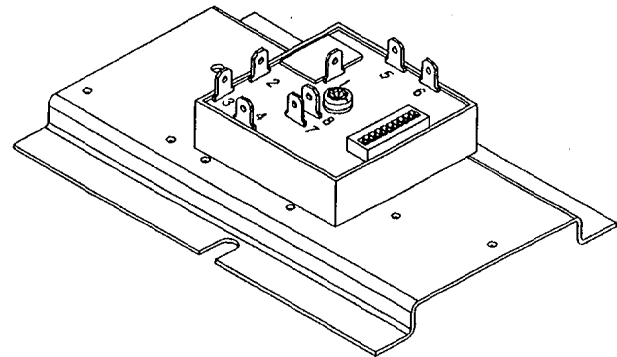
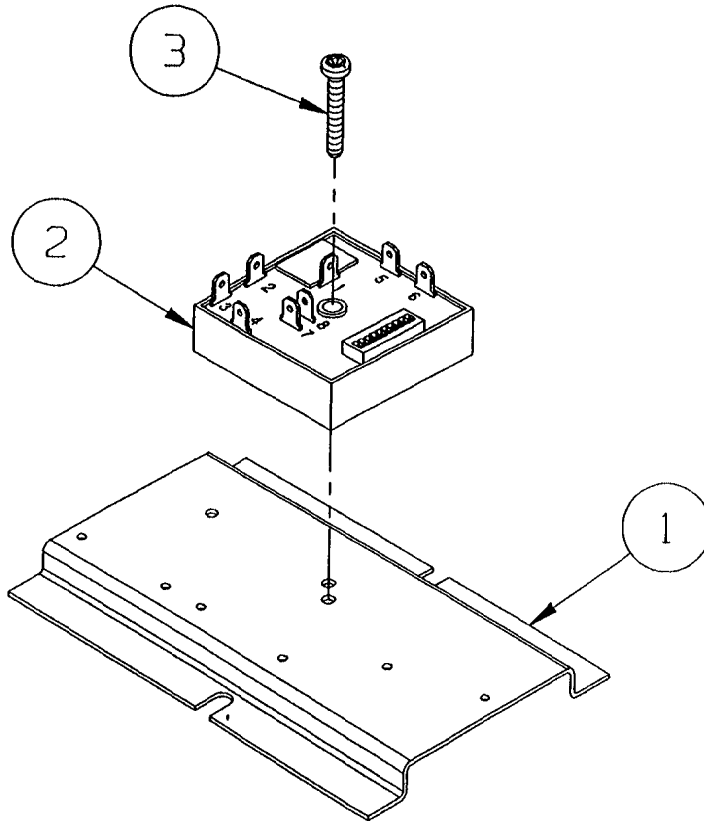
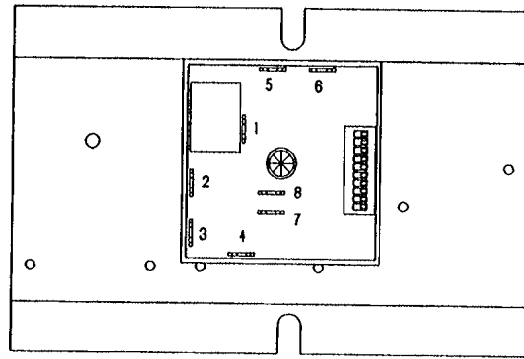

3	1	108124	SCREW, TORX/SLOT #10-32 X 1.00" LG.
2	1	108911	TIMER, CLEAN LIGHT (DIP SWITCHES)
1	1	106306	BRACKET, OPTION PLATE
ITEM	QTY.	PART NO.	DESCRIPTION

TOLERANCES <small>(EXCEPT AS NOTED)</small>			
CLEVELAND RANGE INC. 1333 East 179th St., Cleveland, Ohio 44110-2574			
DECIMAL ± .030	SCALE 1=1	DRAWN BY DUTCHMAN	APPROVED BY
ANGULAR ± 1°	TITLE CLEAN LIGHT TIMER PLATE STEAMCRAFT POWER 10		
CK	DATE 09-15-94	DRAWING NO. C - 107072	REV. -

THIS DESIGN DESCRIBES A PROPRIETARY ITEM AND IS THE PROPERTY OF CLEVELAND RANGE. THIS DRAWING IS NOT TO BE COPIED OR USED WITHOUT THE APPROVAL OF CLEVELAND RANGE.

LET.	REVISIONS	DATE	BY
A	WAS: HIGH LIMIT NOW: FLOAT PER E.O. IC-2381 R1	03-01-93	PJD
B	20351 BLACK WAS FROM FLOAT ONLY PER EO IC-2381 R2	04-14-93	PJD

FOR ON/OFF SWITCH
TIMER

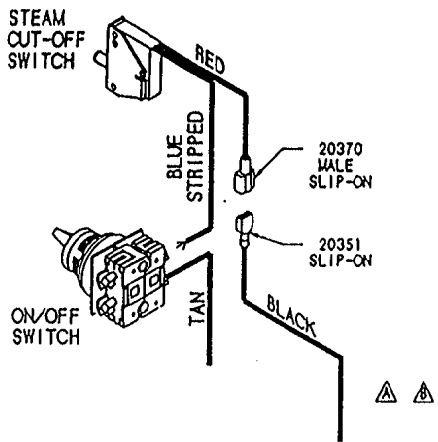

FROM: FLOAT (STANDARD)
GEN. STAND-BY TIMER (SBY OPTION)
BELL TERMINAL (TDS AND SBY OPTIONS TOGETHER)

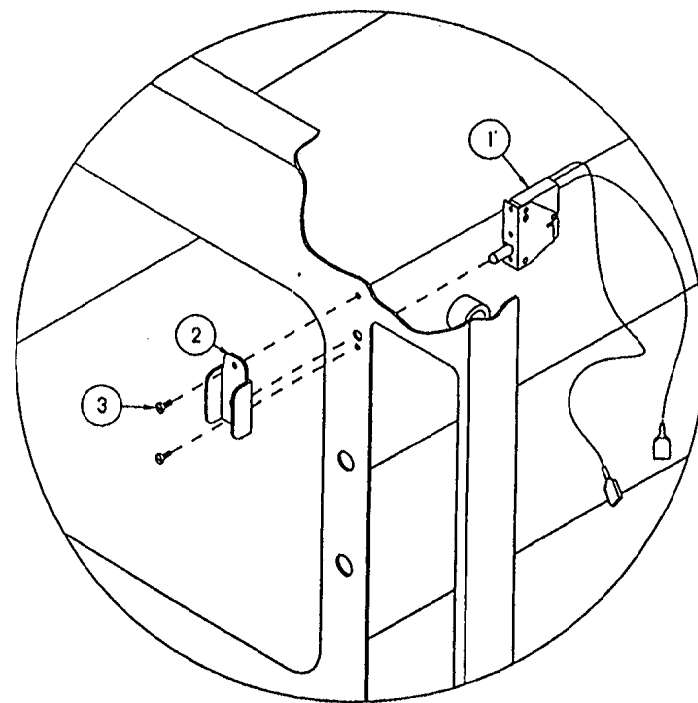

FOR ELECTRICAL & 60 MINUTE
MECHANICAL TIMERS

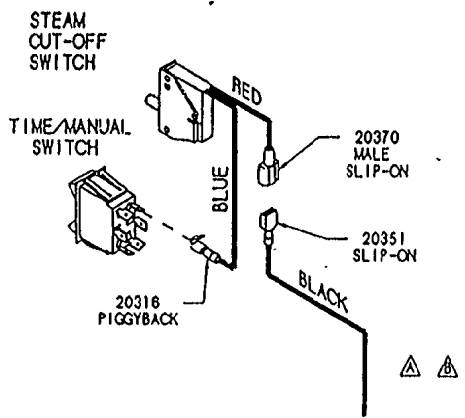

FROM: FLOAT (STANDARD)
GEN. STAND-BY TIMER (SBY OPTION)
BELL TERMINAL (TDS AND SBY OPTIONS TOGETHER)

ITEM	QTY.	PART NO.	DESCRIPTION
3	2	105449	SCREW, TRUSS HD. 6-32 X .312, S/S
2	1	105442	GUARD, SWITCH PROTECTION
1	1	104702	SWITCH, CAPT. STEAM SHUT-OFF

TOLERANCES (UNLESS AS NOTED)		CLEVELAND RANGE INC. 1333 East 179th St. Cleveland, Ohio 44110-2574	
DECIMAL ± .030	SCALE N.T.S.	DRAWN BY DUTCHMAN	APPROVED BY
ANGULAR ± 1°	TITLE STEAM CUT-OFF OPTION STEAMCRAFT 3.1 AND 5.1		
CK	DATE 02-03-93	DRAWING NO. C - 1	REV. 5

THIS DESIGN DESCRIBES A PROPRIETARY ITEM
AND IS THE PROPERTY OF CLEVELAND RANGE.
THIS IS NOT TO BE COPIED OR USED
WITHOUT THE APPROVAL OF CLEVELAND RANGE.

THIS DESIGN DESCRIBES A PROPRIETARY ITEM AND IS THE PROPERTY OF CLEVELAND RANGE. THIS DRAWING IS NOT TO BE COPIED OR USED WITHOUT THE APPROVAL OF CLEVELAND RANGE.

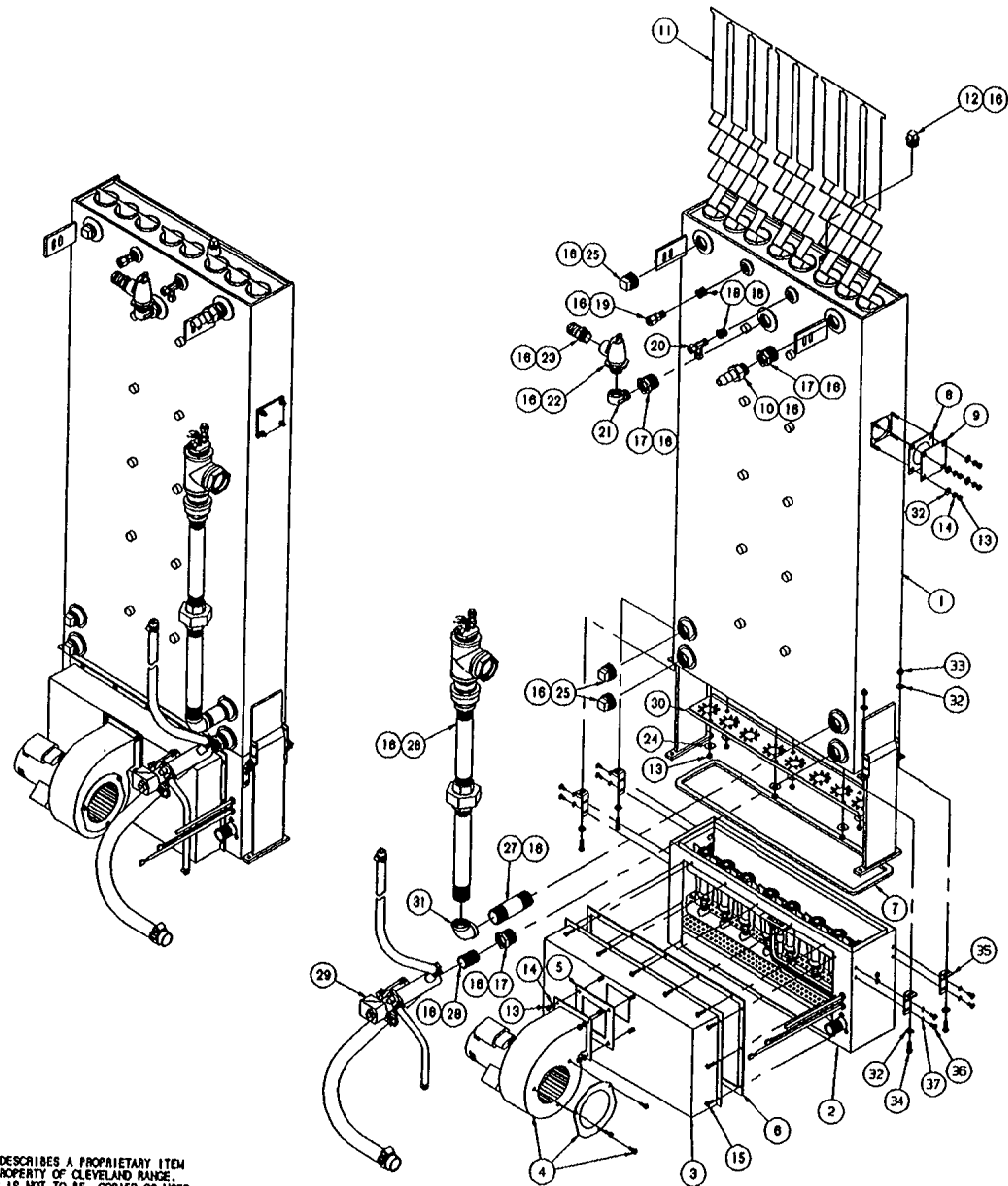

LET.	REVISIONS	DATE	BY
A	ADDED 23118 (QTY 4), AND 106764 WAS QTY 1, IS QTY 8, #C-2881	07-08-94	PJD
B	ADDED BRACKETS TO 106167, ADDED QTY 8 OF 23118, ADDED 14465, 19288, 106941, 101231, 23114, EO #C-2758.	09-27-94	PJD

37	8	23114	WASHER, LOCK, INT. TOOTH, #10
36	8	101231	SCREW, TRUSS HEAD 10-24 X 1/2 LG., S/S
35	4	106941	BRACKET, AIR BOX SUPPORT, PRESSURE 10
34	4	19288	SCREW, HEX HEAD 1/4-20 X 3/4 LG.
33	4	14865	NUT, HEX ELASTIC 1/4-20
32	12	23118	WASHER, FLAT 1/4 X 5/8
31	1	05265	ELBOW, 1" X 90°, BLACK
30	1	106732	PLATE, TURBULATOR
29	1	106887	VALVE ASSY., DRAIN, SC 10 PRESSURE
28	1	14343	HIPPLE, 3/4" X CLOSE, BLACK
27	1	14375	HIPPLE, 1" X 4" LG, BLACK
26	1	106890	FLOC ASSY, SC 10, PRESSURE
25	3	16837	PLUG, SO. HEAD, 1" MPT
24	6	23138	WASHER, FLAT 3/8 X 7/8 X 1/16, S/S
23	1	06185	FITTING, HOSE BARB 3/4 MPT X 1" H, BRASS
22	1	22131	VALVE, SAFETY, 3/4", 15 PSI
21	1	05231	ELBOW, STREET 3/4"
20	1	100883	FITTING, COMP. TEE 3/8 T X 1/4 MPT X 3/8 T
19	1	06195	FITTING, COMP. 3/8 T X 1/4 MPT, STR.
18	2	02594	BUSHING, HEX 3/8 X 1/4, BRASS
17	3	02598	BUSHING, HEX 1 X 3/4
16	A/R	00934	SEALANT, RECTORSEAL
15	11	106126	SCREW, TORX-SLOT PAN HD., 6-32 X 1/2
14	8	23105	WASHER, SPLIT LOCK, 1/4, S/S
13	14	14818	NUT, HEX, 1/4-20, S/S
12	1	18802	PLUG, SO. HEAD, 1/2 PIPE, BLACK
11	8	106784	BAFFLE ASSEMBLY, COMBUSTION
10	1	06240	FITTING, HOSE BARB, 3/4 T X 3/4 MPT
9	1	104814	PLATE, BLOCKOFF
8	1	07128	GASKET, HEATER/BLOCKOFF PLATE
7	1	106725	GASKET, BOILER MOUNT
6	1	106724	GASKET, BURNER MOUNT
5	1	105928	GASKET, FAN MOUNT
4	1	105895	FAN, CENTRIFUGAL, 200 CFM
3	1	106837	CHAMBER, AIR DISTRIBUTION ASSEMBLY
2	1	106885	BURNER BOX ASSEMBLY, NATURAL GAS
1	1	106167	STEAM GENERATOR ASSEMBLY, WELDCONT
ITEM	QTY.	PART NO.	DESCRIPTION

TOLERANCES (EXCEPT AS NOTED)			
CLEVELAND RANGE INC. 1333 East 1791th St., Cleveland, Ohio 44110-2574			
DECIMAL ± N/A	SCALE 5/32=1	DRAWN BY DUTCHMAN	APPROVED BY
ANGULAR ± N/A	TITLE VERTICAL STEAM GENERATOR ASSEMBLY 250,000 BTU, STEAMCRAFT 10		
CK	DATE 02-14-94	DRAWING NO. C - 106886	REV. B

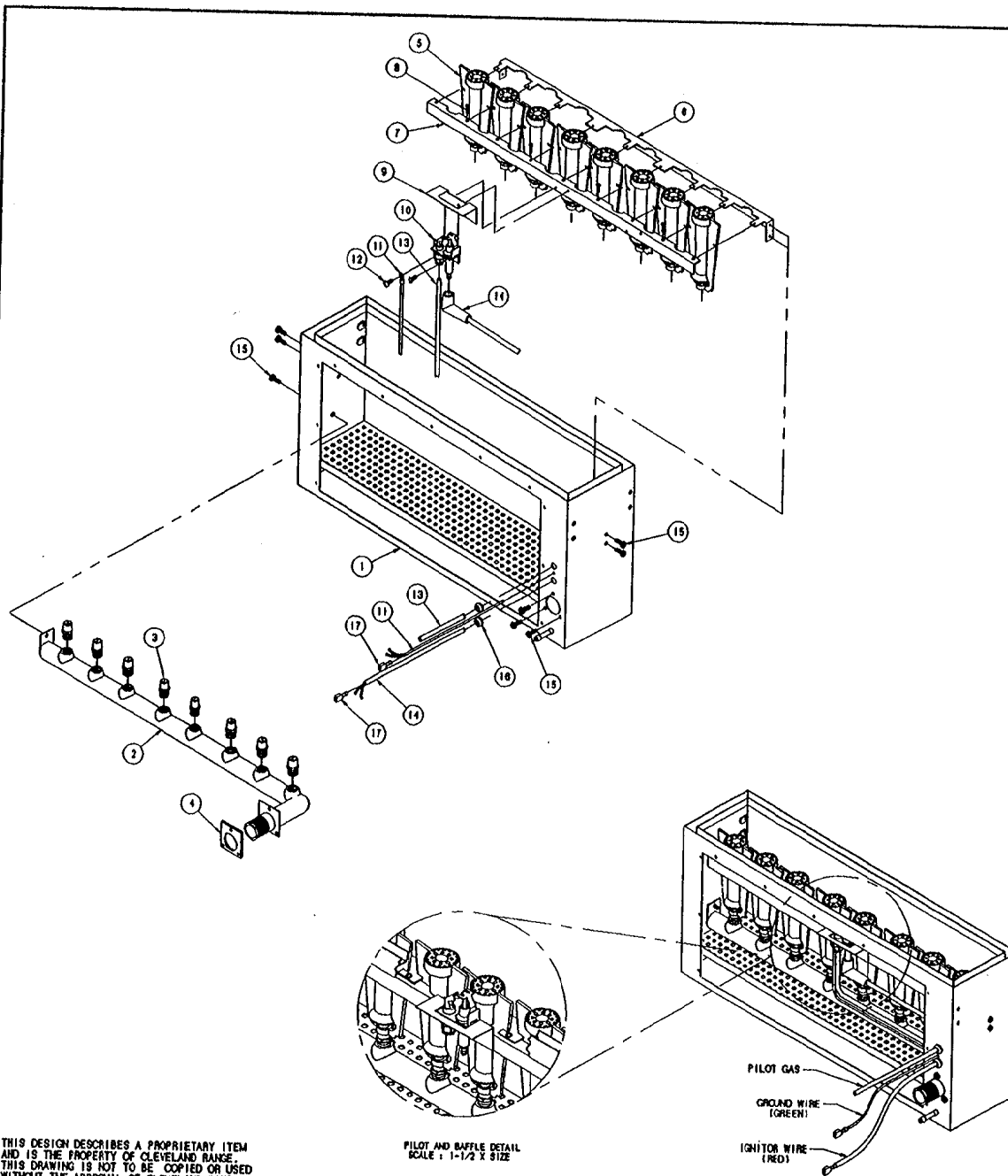

THIS DESIGN DESCRIBES A PROPRIETARY ITEM AND IS THE PROPERTY OF CLEVELAND RANGE. THIS DRAWING IS NOT TO BE COPIED OR USED WITHOUT THE APPROVAL OF CLEVELAND RANGE.

LET.	REVISIONS	DATE	BY
A	1068986000 REPLACED 1061416000 PER E.O. #C-2816	05-05-94	PJD
B	P/N 106848 CORRECTED PICTORIALY PER E.O. #C-2702	08-09-94	PJD
C	ADDED HOLES AND WELDNUTS TO BURNER AIR BOX - SEE E.O. #C-2682	09-27-94	PJD

ITEM	QTY.	PART NO.	DESCRIPTION
17	2	20358	TERMINAL, SLIPON, FULL INSL.
18	2	106129	GROMMET, RUBBER, 1/4" OD
15	8	106123	SCREW, TORX/SLOT PAN HD. #10-32 x 1/2"
14	1	1068986000	WIRE ASSY, IGNITION, 60" LG. (RED)
13	1	106721	TUBE, FORMED, PILOT TO GAS, ALUMINUM
12	2	19114	SCREW, PAN HEAD, PHILLIPS, #8-32 x .375
11	1	1061451700	WIRE ASSY, 18 GA., 17" LG. (GREEN)
10	-	1057841	PILOT ASSEMBLY L.P., INTERMITTENT PILOT
	-	105784	PILOT ASSY, NATURAL GAS, INTERM. PILOT
9	1	106412	BAFFLE, AIR, PILOT
8	4	101879	SCREW, HEX WASH HEAD, #8-32 x 1/2"
7	1	106644	BRACKET, BURNER CLAMPING
6	1	106643	BRACKET, BURNER SUPPORT
5	8	105781	BURNER, INSHOT, 30,000 BTU
4	1	106720	GASKET, GAS MANIFOLD
3	-	1067821	ORIFICE, LP GAS, VERTICAL BOILER
	-	106782	ORIFICE, GAS, NATURAL, VERTICAL BOILER
2	1	106640	MANIFOLD ASSY, GAS, 250,000 BTU BOILER
1	1	106646	BURNER AIR BOX, WELD ASSEMBLY

TOLERANCES (EXCEPT AS NOTED)

DECIMAL ± N/A
ANGULAR ± N/A

SCALE 1/2=1"
TITLED

DRAWN BY Dutchman
APPROVED BY

CLEVELAND RANGE INC.
1333 East 179th St. Cleveland, Ohio 44110-2574

BURNER BOX ASSEMBLY
250,000 BTU VERTICAL BOILER
NATURAL GAS / LP GAS

DATE 02-14-94
DRAWING NO. C - 106685
REV. C

NOTES:

1.) ITEM (1) P/N 21305 MUST BE ASSEMBLED AS SHOWN.

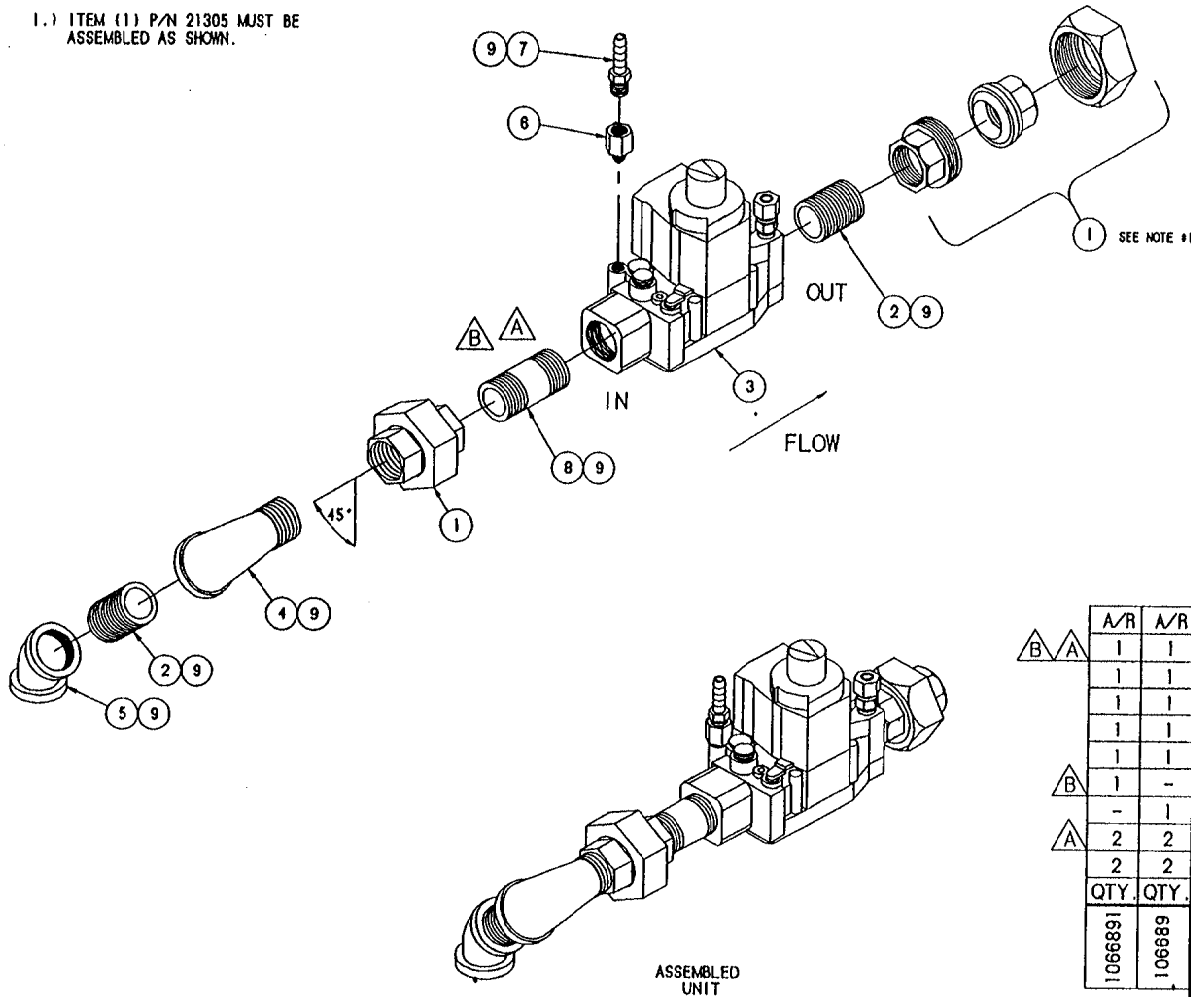

LET.	REVISIONS	DATE	BY
A	REPLACED ONE OF 14343 WITH 14345 SEE EO C-2018.	4/28/94	DLD
B	REPLACED 14345 WITH 14344, AND 1067191 WITH 1067192, C-2708.	8/23/94	DLD

A/R	A/R	9		
1	1	8	14344	SEALANT, RECTORSEAL
1	1	7	104380	NIPPLE, 3/4 X 2", BLACK
1	1	6	106803	FITTING, HOSE BARB 1/4 H X 1/8 MPT
1	1	5	05262	FITTING, ADAPTER 1/8 T X 1/8 NPT
1	1	4	05259	ELBOW, 3/4" X 45°, BLACK
1	-	3	1067192	ELBOW, STREET, 90°, 3/4, BLACK
-	1		106719	VALVE, GAS REGULATOR, LIQUID PROPANE
2	2	2	14343	VALVE, GAS REGULATOR, NATURAL GAS
2	2	1	21305	NIPPLE, 3/4 x CLOSE, BLACK
QTY.	QTY.	ITEM	PART NO.	DESCRIPTION

1066891	106689	TOLERANCES (EXCEPT AS NOTED)	CLEVELAND RANGE INC. 1333 East 179th St. Cleveland, Ohio 44110-2574		
± N/A	SCALE 1/4=1	DRAWN BY DUTCHMAN	APPROVED BY		
± N/A	TITLE GAS VALVE ASSEMBLY SC 10, VERTICAL PRESSURE				
CK	DATE 02-21-94	DRAWING NO. B - 106689 1066891	REV. B		

THIS DESIGN DESCRIBES A PROPRIETARY ITEM AND IS THE PROPERTY OF CLEVELAND RANGE. THIS DRAWING IS NOT TO BE COPIED OR USED WITHOUT THE APPROVAL OF CLEVELAND RANGE.

LET.	REVISIONS	DATE	BY
------	-----------	------	----

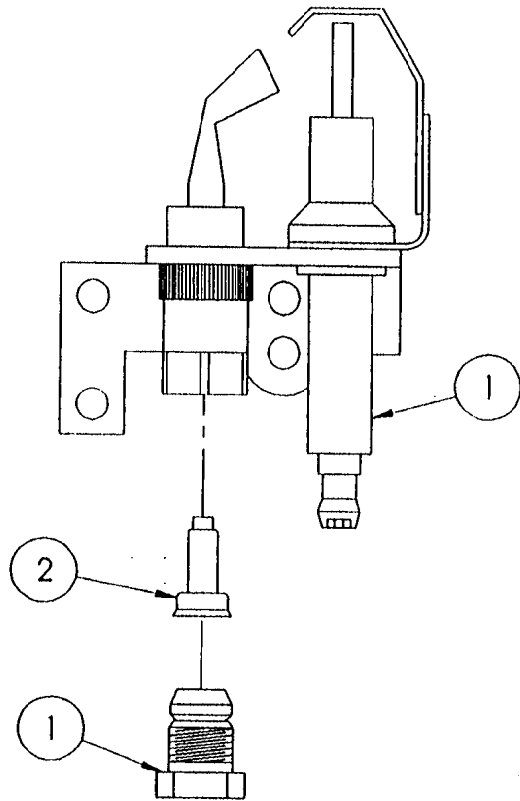

NOTE:

- 1.) REMOVE ORIFACE FROM P/N 105784 AND DISCARD.
- 2.) INSTALL P/N 106375.

2	1	106375	ORIFICE, PILOT, 0.012"	
1	1	105784	PILOT	
ITEM	QTY.	PART NO.	DESCRIPTION	
TOLERANCES (EXCEPT AS NOTED)		CLEVELAND RANGE INC. 1333 East 179th St. Cleveland, Ohio 44110-2574		
DECIMAL ± N/A		SCALE 1=1	DRAWN BY DUTCHMAN	APPROVED BY -
ANGULAR ± N/A		TITLE PILOT ASSEMBLY, L.P. STEAMCRAFT 10		
CK		DATE 02-22-93	DRAWING NO. A - 1057841	REV. -

THIS DESIGN DESCRIBES A PROPRIETARY ITEM AND IS THE PROPERTY OF CLEVELAND RANGE. THIS DRAWING IS NOT TO BE COPIED OR USED WITHOUT THE APPROVAL OF CLEVELAND RANGE.

NOTES:

- 1.) USE LOCKTITE #222 - LOW STRENGTH (#104146) ON ITEM 4
- 2.) USE RTV (#100933) ON ITEM 6
- 3.) ORIENT LONGER SIDE OF ITEM 5 TOWARD HANDLE

LET.	REVISIONS	DATE	BY
A	REDRAWN CADKEY, ADDED P/NS 103901 NAMEPLATE AND 104987 TINNEMAN NUT. PICTORIAL CHANGE PER EO KC-2441R2	06-28-93	PJD
B	P/NS 105901 & 104987 REF. ONLY AND MOVED TO UNDER DOOR LATCH PER E.O. KC-2441 R3	08-05-93	PJD
C	REMOVED P/NS 105901 AND 104987 PER E.O. KC-2441 R8	06-07-94	PJD

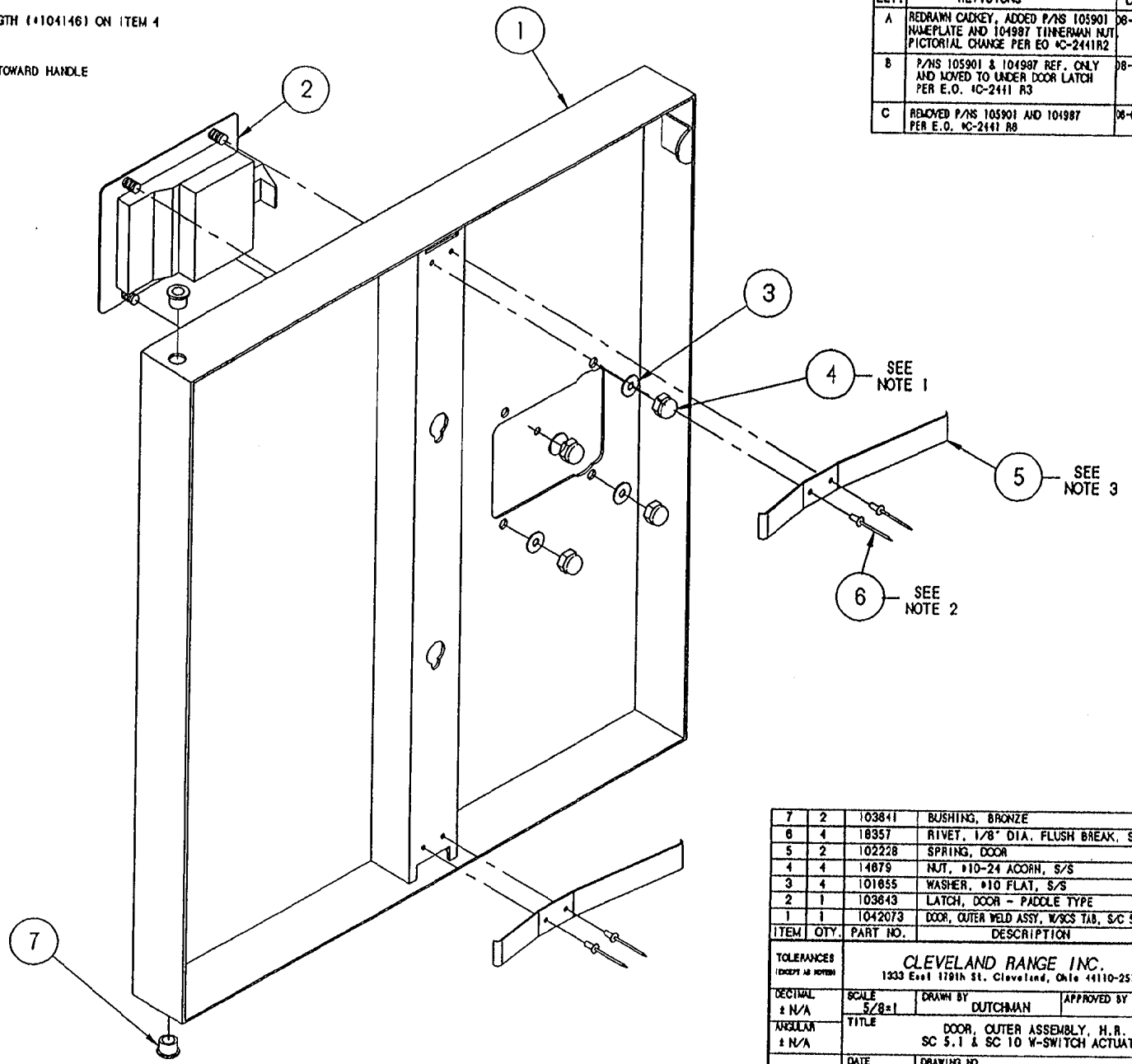

THIS DESIGN DESCRIBES A PROPRIETARY ITEM AND IS THE PROPERTY OF CLEVELAND RANGE. THIS DRAWING IS NOT TO BE COPIED OR USED WITHOUT THE APPROVAL OF CLEVELAND RANGE.

ITEM	QTY	PART NO.	DESCRIPTION
7	2	103841	BUSHING, BRONZE
6	4	18357	RIVET, 1/8" DIA. FLUSH BREAK, S/S
5	2	102228	SPRING, DOOR
4	4	14879	NUT, #10-24 ACORN, S/S
3	4	101655	WASHER, #10 FLAT, S/S
2	1	103843	LATCH, DOOR - PADDLE TYPE
1	1	1042073	DOOR, OUTER WELD ASSY, W/SCS TAB, S/C S.I. H.R.

TOLERANCES <small>(EXCEPT AS NOTED)</small>				CLEVELAND RANGE INC. 1333 East 179th St. Cleveland, Ohio 44110-2574			
DECIMAL ± N/A	SCALE 5/8=1	DRAWN BY DUTCHMAN	APPROVED BY				
ANGULAR ± N/A	TITLE DOOR, OUTER ASSEMBLY, H.R. SC S.I & SC 10 W-SWITCH ACTUATOR						
OK	DATE 06-30-93	DRAWING NO. C - 1042063	REV. C				

- NOTES : 1.) USE LOCTITE #222 - LOW STRENGTH (#104146) ON ITEM 4
 2.) USE RTV (#00933) ON ITEM 6
 3.) ORIENT LONGER SIDE OF ITEM 5 TOWARD HANDLE

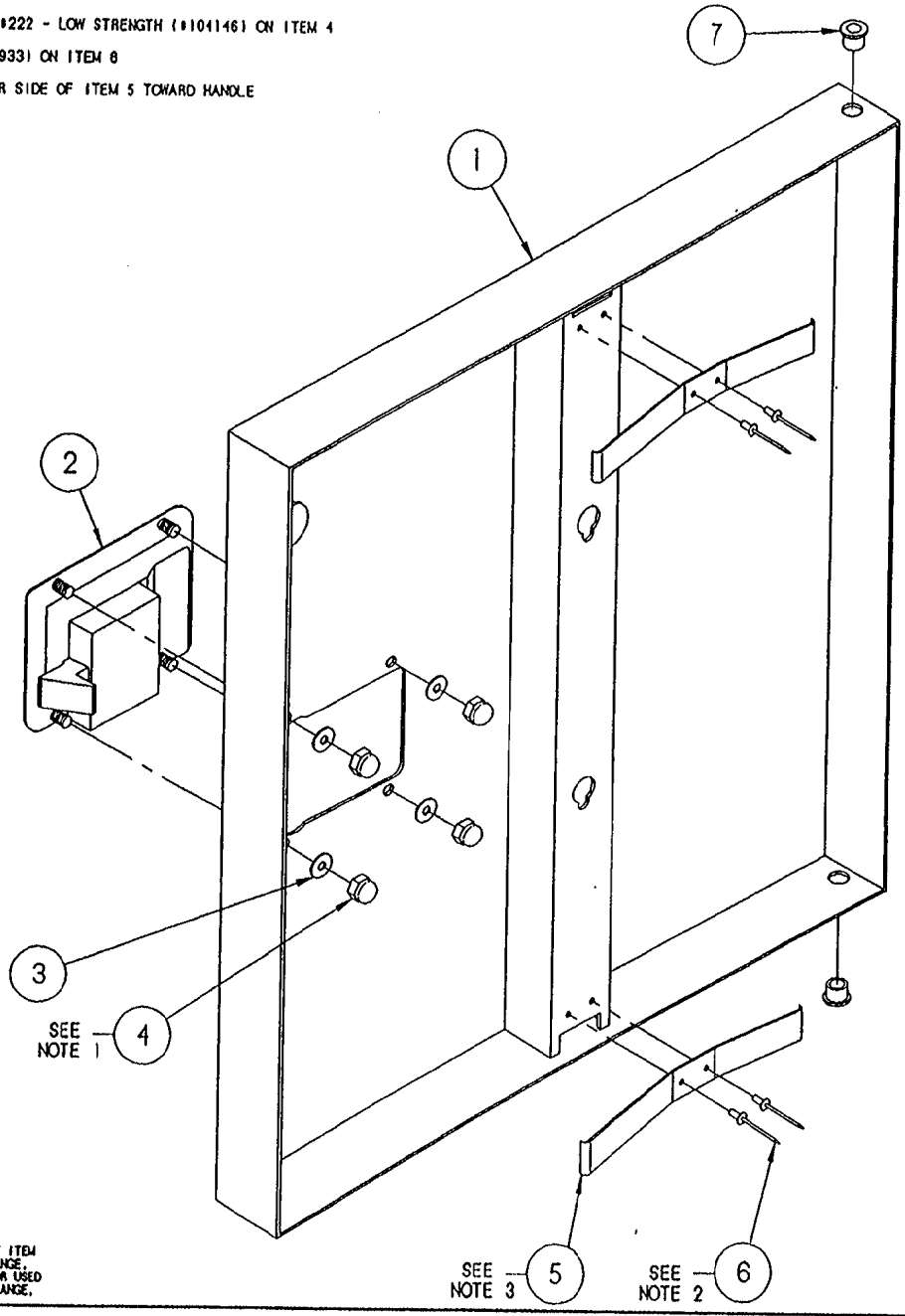

THIS DESIGN DESCRIBES A PROPRIETARY ITEM AND IS THE PROPERTY OF CLEVELAND RANGE. THIS DRAWING IS NOT TO BE COPIED OR USED WITHOUT THE APPROVAL OF CLEVELAND RANGE.

LET.	REVISIONS	DATE	BY
A	REDRAW CADKEY, ADDED P/NS 105901 NAMEPLATE AND 104987 TINNEMAN NUT, PICTORIAL CHANGE PER EO KC-2441R2	06-30-93	J.D
B	P/NS 105901 & 104987 REF. ONLY PER E.O. KC-2441 R3	08-05-93	J.D
C	REMOVED P/NS 105901 AND 104987 PER E.O. KC-2441 R8	06-07-94	J.D

ITEM	QTY.	PART NO.	DESCRIPTION
7	2	103841	BUSHING, BRONZE
6	4	18357	RIVET, 1/8" DIA. FLUSH BREAK, S/S
5	2	102228	SPRING, DOOR
4	4	14879	NUT, #10-24 ACORN, S/S
3	4	101855	WASHER, #10 FLAT, S/S
2	1	103843	LATCH, DOOR - PADDLE TYPE
1	1	1042072	DOOR, OUTER WELD ASSY, W/SCS TAB, S/C S.I., H.L.

TOLERANCES (EXCEPT AS NOTED)		CLEVELAND RANGE INC. 1333 East 179th St. Cleveland, Ohio 44110-2574	
DECIMAL ± N/A	SCALE 5/8=1	DRAWN BY JTW	APPROVED BY
ANGULAR ± N/A	TITLE DOOR, OUTER ASSEMBLY, H.L. SC 5.1 & SC 10 W-SWITCH ACTUATOR		
CK	DATE 02-04-93	DRAWING NO. C - 1042062	REV. C

NOTES:

- 1) FIRST ATTACH BOTTOM ANGLE (P/N 106844)
NEXT ASSEMBLE DOOR (P/N 106845) INTO PLACE
THEN ATTACH TOP ANGLE ON TO SIDE PANEL

LET.	REVISIONS	DATE	BY

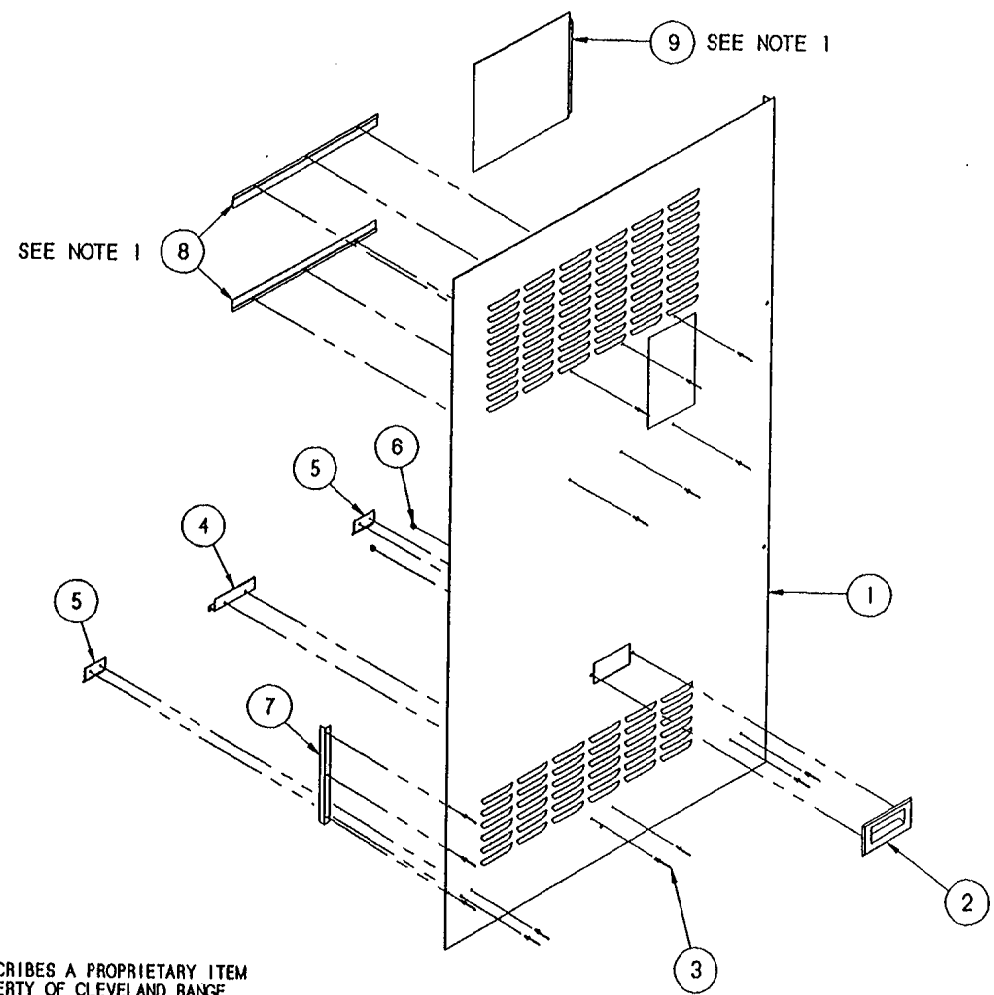

ITEM	QTY.	PART NO.	DESCRIPTION
9	1	106845	DOOR, PANEL, RIGHT, SC 10
8	2	106844	ANGLE, DOOR, PANEL, SC 10
7	1	106143	ANGLE, REINFORCEMENT
6	2	14676	NUT, ACORN 10-32 S/S
5	2	106045	BRACKET, SIDE SUPPORT, SHT.
4	1	106044	BRACKET, SIDE SUPPORT, LG.
3	15	18357	RIVET, FLUSH 1/8 S/S
2	1	08108	HANDLE, DOOR, S/S
1	1	106682	PANEL, SIDE, RIGHT, SC 10

TOLERANCES (EXCEPT AS NOTED)		CLEVELAND RANGE INC. 1333 East 179th St. Cleveland, Ohio 44110-2574	
DECIMAL ± N/A	SCALE 1/8 = 1	DRAWN BY DUTCHMAN	APPROVED BY BEDFORD
ANGULAR ± N/A	TITLE PANEL, SIDE, RIGHT, ASSY. STEAMCRAFT POWER 10		
CK	DATE 03-01-94	DRAWING NO. B - 106666	REV. -

THIS DESIGN DESCRIBES A PROPRIETARY ITEM AND IS THE PROPERTY OF CLEVELAND RANGE. THIS DRAWING IS NOT TO BE COPIED OR USED WITHOUT THE APPROVAL OF CLEVELAND RANGE.

LET.	REVISIONS	DATE	BY
------	-----------	------	----

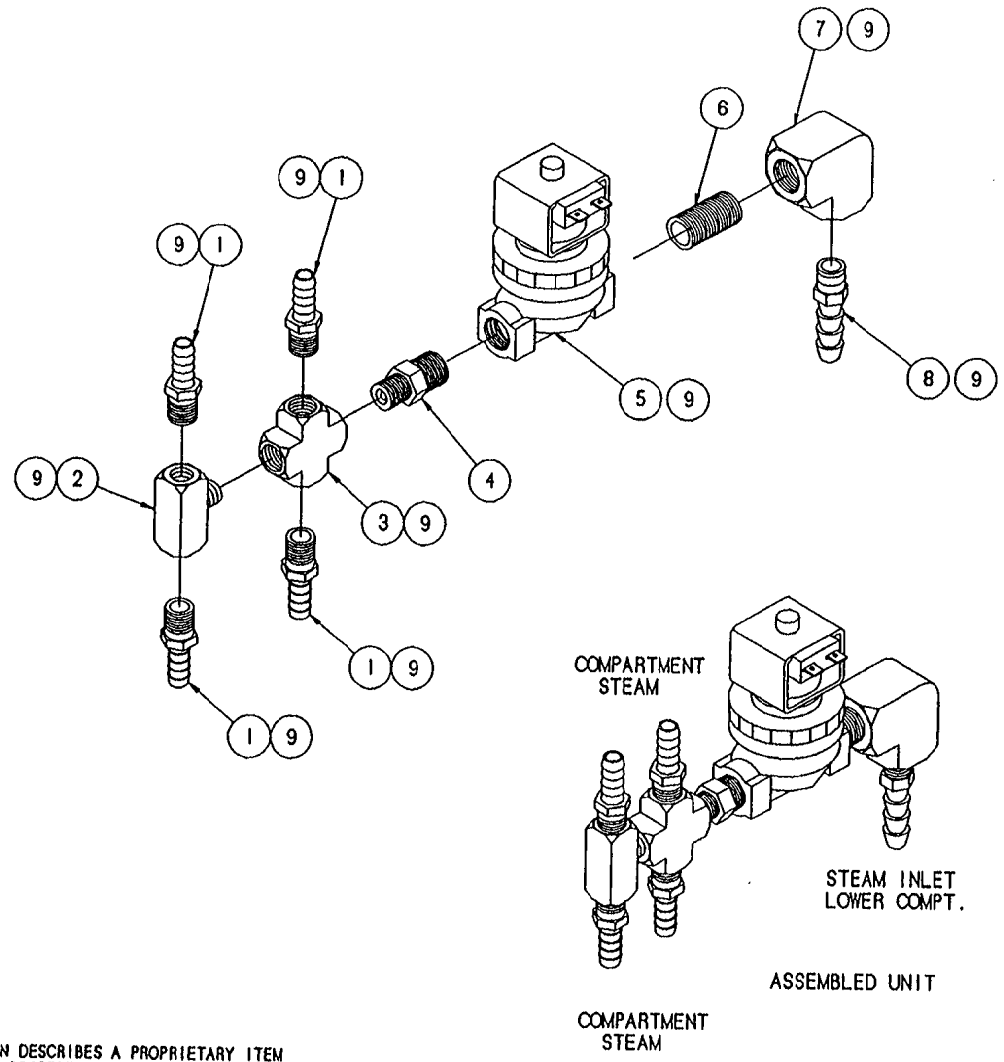

THIS DESIGN DESCRIBES A PROPRIETARY ITEM AND IS THE PROPERTY OF CLEVELAND RANGE. THIS DRAWING IS NOT TO BE COPIED OR USED WITHOUT THE APPROVAL OF CLEVELAND RANGE.

9	A/R	00934	SEALANT, RECTORSEAL
8	1	100746	FITTING, HOSE BARB, 1/2 H X 3/8 NPT
7	1	05244	ELBOW, 3/8 X 90°, BRASS
6	1	14427	NIPPLE, 3/8 X CLOSE, BRASS
5	1	22224	STEAM VALVE, SOLENOID 3/8 X 3/8
4	1	106791	FLOW RESTRICTOR
3	1	03729	CROSS, 4-WAY, 1/4", BRASS
2	1	20245	TEE, MALE BRANCH, 1/4", BRASS
1	4	105277	FITTING, HOSE BARB, 3/8 H X 1/4 NPT
ITEM	QTY.	PART NO.	DESCRIPTION

<p>TOLERANCES (EXCEPT AS NOTED)</p> <p>DECIMAL ± .030</p> <p>ANGULAR ± 1°</p>			
<p>CLEVELAND RANGE INC. 1333 East 179th St. Cleveland, Ohio 44110-2574</p>			
SCALE	1/2" = 1"	DRAWN BY	APPROVED BY
		P. DUTCHMAN	J.B.
<p>TITLE STEAM INLET ASSY, UPPER COMPT. STEAMCRAFT 10, GAS, PRESSURE</p>			
DATE	02-21-94	DRAWING NO.	B - 106691
CK			REV. -

LET.	REVISIONS	DATE	BY
------	-----------	------	----

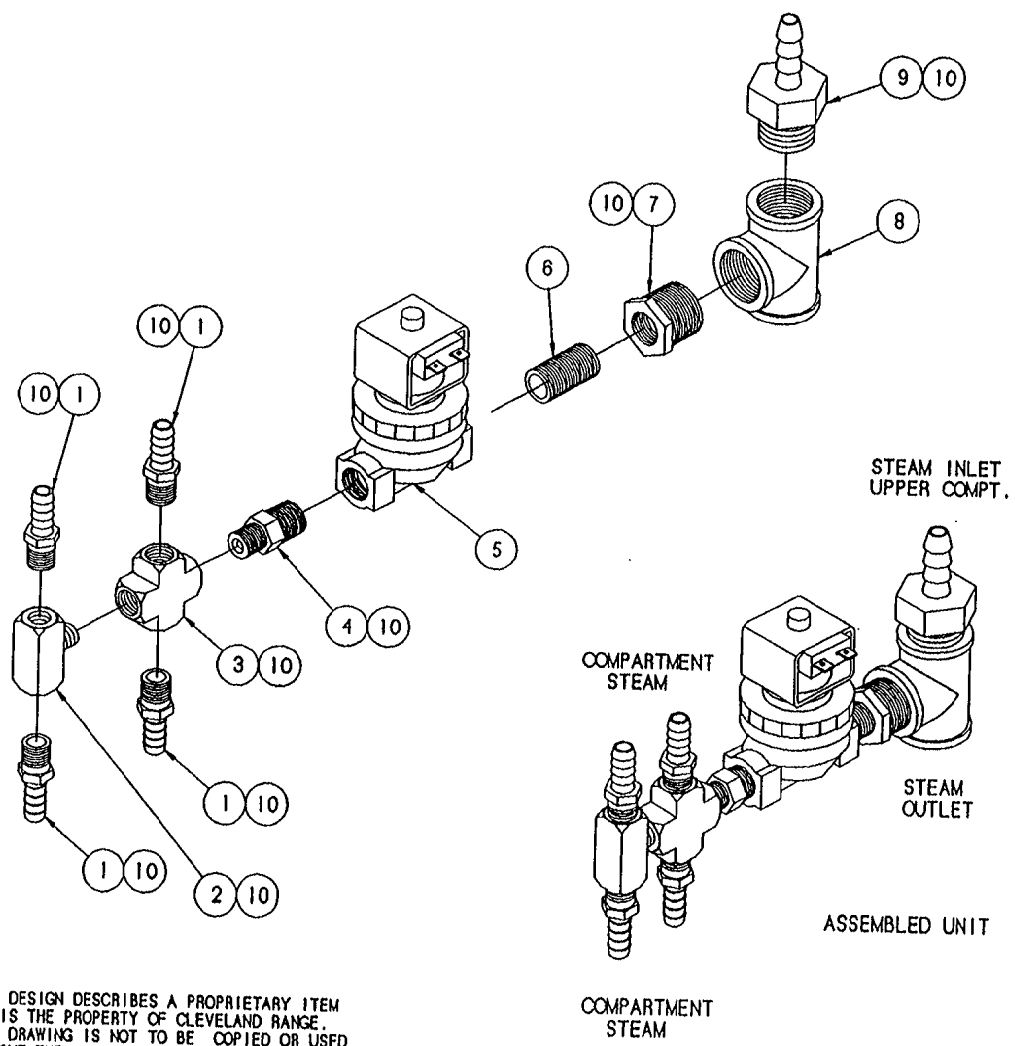

THIS DESIGN DESCRIBES A PROPRIETARY ITEM AND IS THE PROPERTY OF CLEVELAND RANGE. THIS DRAWING IS NOT TO BE COPIED OR USED WITHOUT THE APPROVAL OF CLEVELAND RANGE.

ITEM	QTY.	PART NO.	DESCRIPTION
10	A/R	00934	SEALANT, RECTORSEAL
9	1	06235	FITTING, HOSE BARB, 1/2 H X 3/4 WPT
8	1	20206	TEE, 3/4", BRASS
7	1	02575	BUSHING, HEX 3/4 X 3/8, BRASS
6	1	14427	NIPPLE, 3/8 X CLOSE, BRASS
5	1	22224	STEAM VALVE, SOLENOID 3/8 X 3/8
4	1	108791	FLOW RESTRICTOR
3	1	03729	CROSS, 4-WAY, 1/4", BRASS
2	1	20245	TEE, MALE BRANCH, 1/4", BRASS
1	4	105277	FITTING, HOSE BARB, 3/8 H X 1/4 NPT

TOLERANCES (EXCEPT AS NOTED)		CLEVELAND RANGE INC. 1333 East 179th St. Cleveland, Ohio 44110-2574	
DECIMAL ± .030	SCALE 1/2" = 1"	DRAWN BY P. DUTCHMAN	APPROVED BY J.B.
ANGULAR ± 1°	TITLE STEAM INLET ASSY, LOWER COMPT. STEAMCRAFT 10, GAS, PRESSURE		
CK	DATE 02-14-94	DRAWING NO. B - 106692	REV. -

LET.

REVISIONS

DATE BY

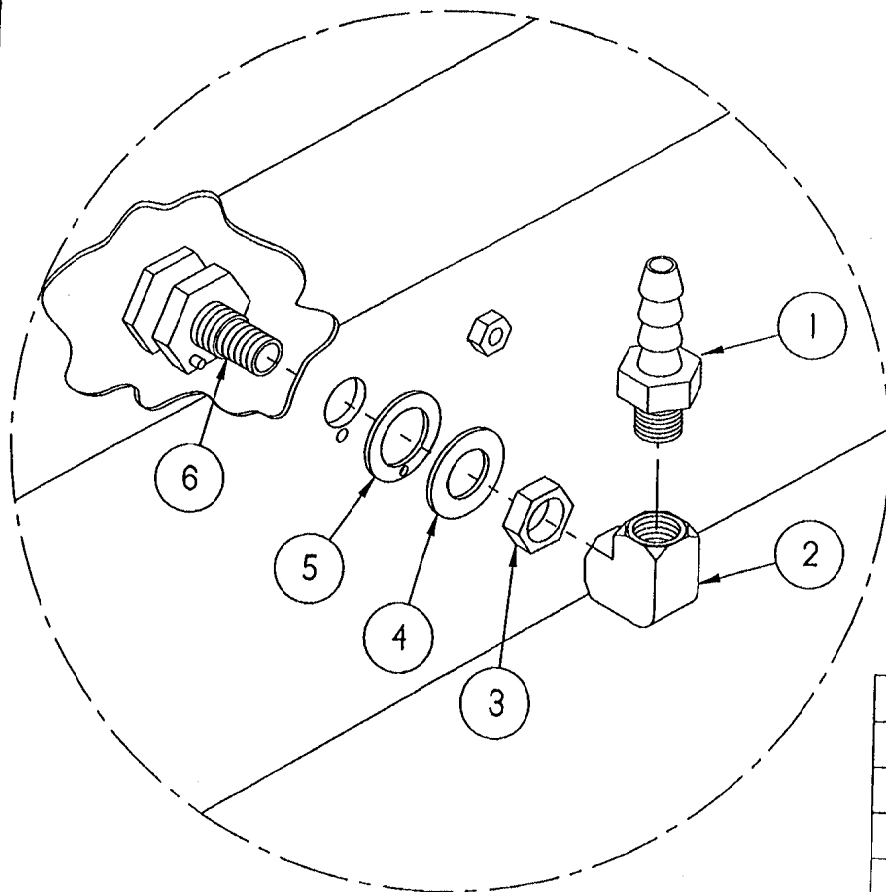

TYPICAL APPLICATION

6	1	104009	FITTING, ASSY, STEAM SUPPLY
5	1	104082	GASKET, STEAM INJECTOR
4	1	104232	WASHER, FLAT S/S
3	1	104081	NUT, JAM 5/8-18, BRASS
2	1	05236	ELBOW, 1/4" X 90°, BRASS
1	1	104048	FITTING, HOSE 1/2 H X 1/4 MPT
ITEM	QTY.	PART NO.	DESCRIPTION

TOLERANCES
(EXCEPT AS NOTED)DECIMAL
± .030ANGULAR
± 1°

CLEVELAND RANGE INC.
1333 East 179th St. Cleveland, Ohio 44110-2574

SCALE
1/2"DRAWN BY
DUTCHMANAPPROVED BY
THOMPSON

TITLE
SPRAY NOZZLE ASSEMBLY
STEAMCRAFT 3.1, 5.1 AND 10

CK

DATE
02-12-93DRAWING NO.
A - 1062301REV.
-

THIS DESIGN DESCRIBES A PROPRIETARY ITEM
AND IS THE PROPERTY OF CLEVELAND RANGE.
THIS DRAWING IS NOT TO BE COPIED OR USED
WITHOUT THE APPROVAL OF CLEVELAND RANGE.

LET.	REVISIONS	DATE	BY
------	-----------	------	----

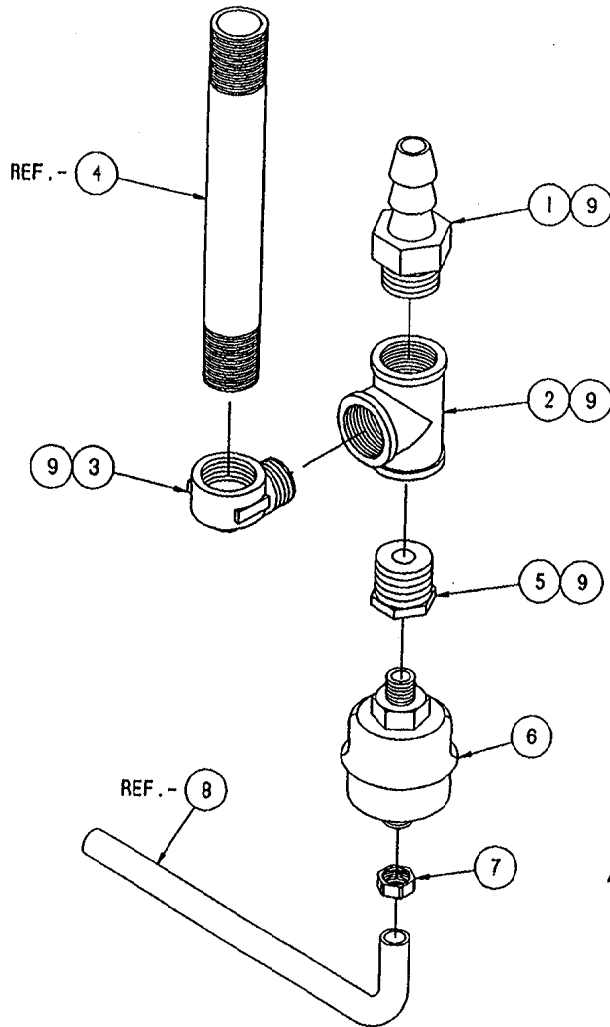

GENERATOR
STEAM OUTLET

STEAM INLET
LOWER COMPT.

ASSEMBLED UNIT

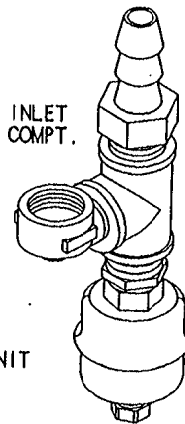

TO DRAIN
MANIFOLD

THIS DESIGN DESCRIBES A PROPRIETARY ITEM
AND IS THE PROPERTY OF CLEVELAND RANGE.
THIS DRAWING IS NOT TO BE COPIED OR USED
WITHOUT THE APPROVAL OF CLEVELAND RANGE.

REF.	QTY.	A/R	PART NO.	DESCRIPTION
			00934	SEALANT, RECTORSEAL
REF. -		-	106808	TUBE, FORMED, 1/4" COPPER
		1	14661	NUT, COMPRESSION, 1/4 X 1/4
		1	101207	TRAP, THERMOSTATIC, 1/4"
		1	02563	BUSHING, HEX 3/4 X 1/4, BRASS
REF. -		-	14466	NIPPLE, 3/4" X 8" LG.
		1	05231	ELBOW, STREET, 3/4", BRASS
		1	20208	TEE, 3/4", BRASS
		1	06240	FITTING, HOSE BARB, 3/4 NPT X 3/4 H
ITEM	QTY.	PART NO.	DESCRIPTION	

TOLERANCES
(EXCEPT AS NOTED)

CLEVELAND RANGE INC.
1333 East 179th St. Cleveland, Ohio 44110-2574

DECIMAL
± .030

SCALE
1/2" = 1"

DRAWN BY
P. DUTCHMAN

APPROVED BY
J.B.

ANGULAR
± 1°

TITLE
STEAM OUTLET ASSEMBLY
STEAMCRAFT 10, GAS, PRESSURE

CK

DATE
02-14-94

DRAWING NO.
B - 106693

REV.
-

LET.	REVISIONS	DATE	BY
A	P/N 105786 MOVED TO MIDDLE SOLENOID IN PICTORIAL PER EO #C-2304	10-28-92	PD
B	NEW VALVE REPLACING P/N 22218 (PICTORIAL ONLY) PER E.O.#C-2221 RI	01-28-93	PJD

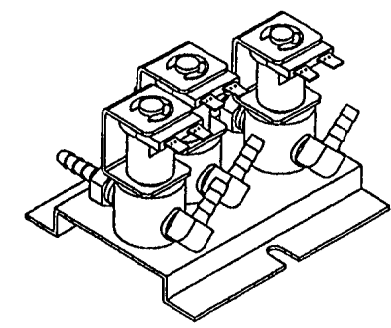
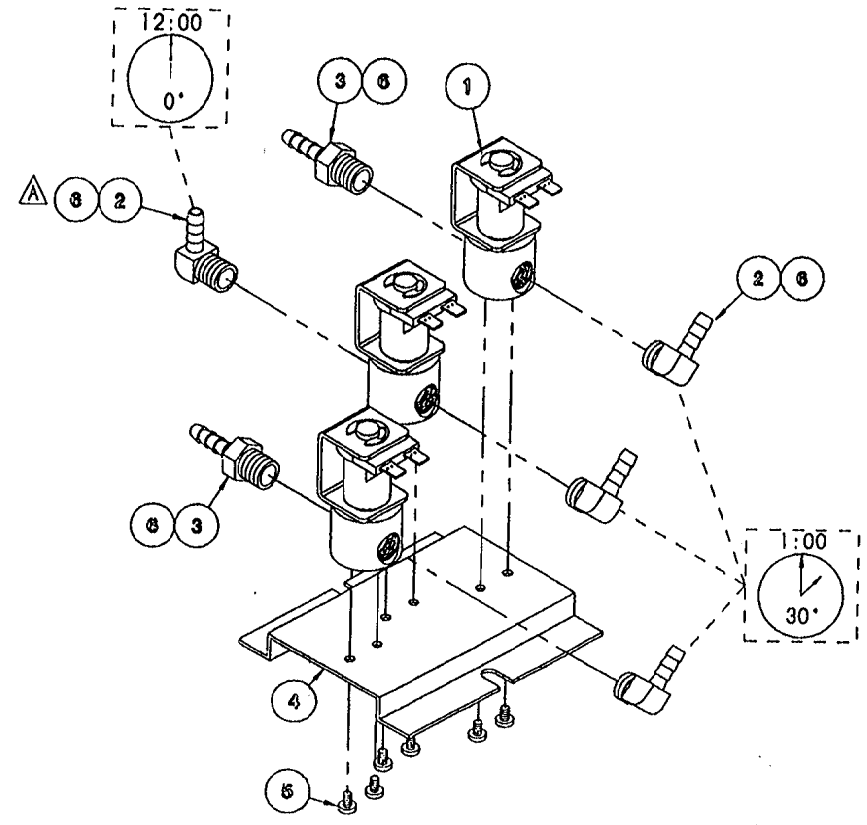

ITEM	QTY.	PART NO.	DESCRIPTION
6	A/R	00934	SEALANT, RECTORSEAL
5	6	101872	SCREW, THREAD CUTTING, #8-32 x .25
4	1	104284	BRACKET, MOUNTING, SOLENOID
3	2	104381	FITTING, HOSE BARB, 1/4 H x 1/4, ST.
2	4	105786	FITTING, HOSE BARB, 1/4 H x 1/4, 90°
1	3	22218	VALVE, SOLENOID, 1/4", N.C., 120 V

TOLERANCES (EXCEPT AS NOTED)		CLEVELAND RANGE INC. 1333 East 179th St. Cleveland, Ohio 44110-2574	
DECIMAL ± N/A	SCALE 1/2=1	DRAWN BY S. MILEWSKI	APPROVED BY
ANGULAR ± N/A	TITLE VALVE ASSEMBLY, WATER INLET STEAMCRAFT 10, ELECTRIC		
CK	DATE 7-16-92	DRAWING NO. B - 105981	REV. B

THIS DESIGN DESCRIBES A PROPRIETARY ITEM AND IS THE PROPERTY OF CLEVELAND RANGE. THIS DRAWING IS NOT TO BE COPIED OR USED WITHOUT THE APPROVAL OF CLEVELAND RANGE.

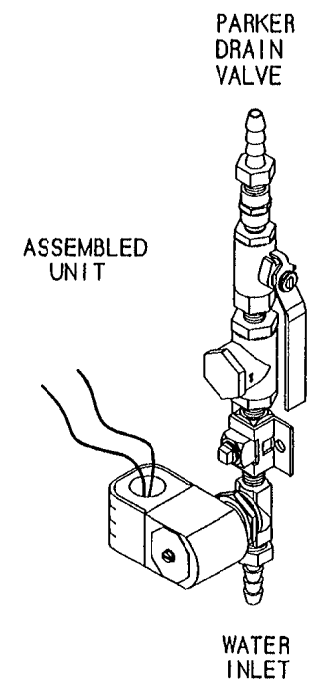
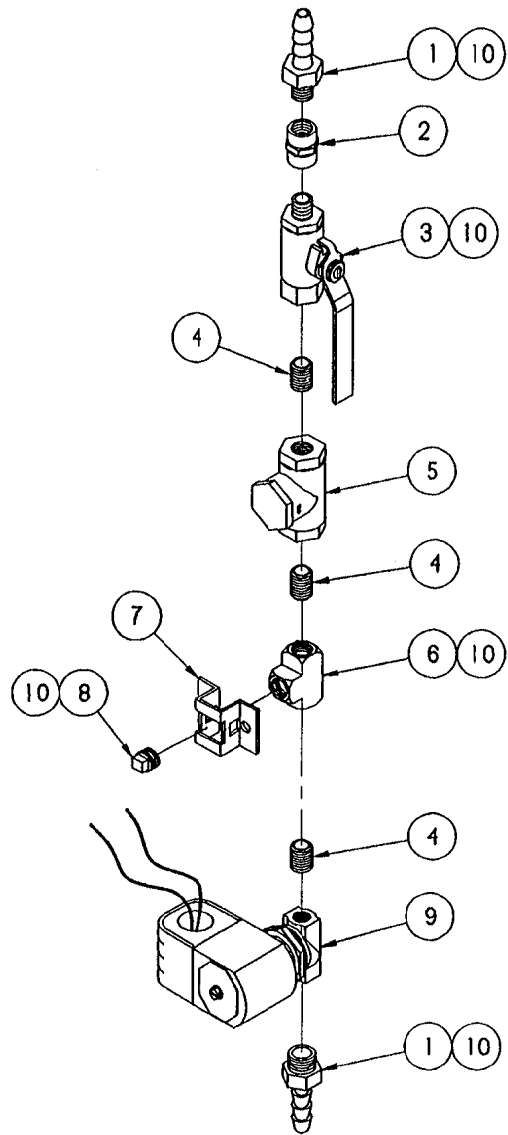

ITEM	QTY.	PART NO.	DESCRIPTION
10	A/R	00934	SEALANT, RECTORSEAL
9	1	22223	VALVE, SOLENOID, 1/4"
8	1	16819	PLUG, SQUARE HEAD, 1/4"
7	1	100084	BRACKET, MOUNTING CLAMP
6	1	20199	TEE, 1/4" BRASS
5	1	22102	VALVE, CHECK, 1/4"
4	3	14304	NIPPLE, 1/4 X CLOSE, BRASS
3	1	03276	VALVE, BALL, 1/4"
2	1	03873	COUPLING, 1/4"
1	2	104048	HOSE BARB, 1/4 MPT X 1/2 H

TOLERANCES (EXCEPT AS NOTED)		CLEVELAND RANGE INC. 1333 East 179th St., Cleveland, Ohio 44110-2574	
DECIMAL ± N/A	SCALE 1/2=1	DRAWN BY DUTCHMAN	APPROVED BY
ANGULAR ± N/A	TITLE PIPING ASSY, WATER FEED, SC 10 GAS, VERTICAL PRESSURE BOILER		
CK	DATE 02-14-94	DRAWING NO. C - 106702	REV. -

THIS DESIGN DESCRIBES A PROPRIETARY ITEM AND IS THE PROPERTY OF CLEVELAND RANGE. THIS DRAWING IS NOT TO BE COPIED OR USED WITHOUT THE APPROVAL OF CLEVELAND RANGE.

NOTE 1:
 COMPRESSION TEE FITTING MUST BE
 POSITIONED INTO THE STRAIGHT
 THRU HOLE OF THE FLOAT ADAPTER



AS ASSEMBLED
 ON STEAMCRAFT 10
 PRESSURE GENERATOR

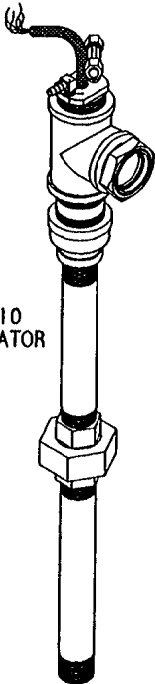

THIS DESIGN DESCRIBES A PROPRIETARY ITEM
 AND IS THE PROPERTY OF CLEVELAND RANGE.
 THIS DRAWING IS NOT TO BE COPIED OR USED
 WITHOUT THE APPROVAL OF CLEVELAND RANGE.

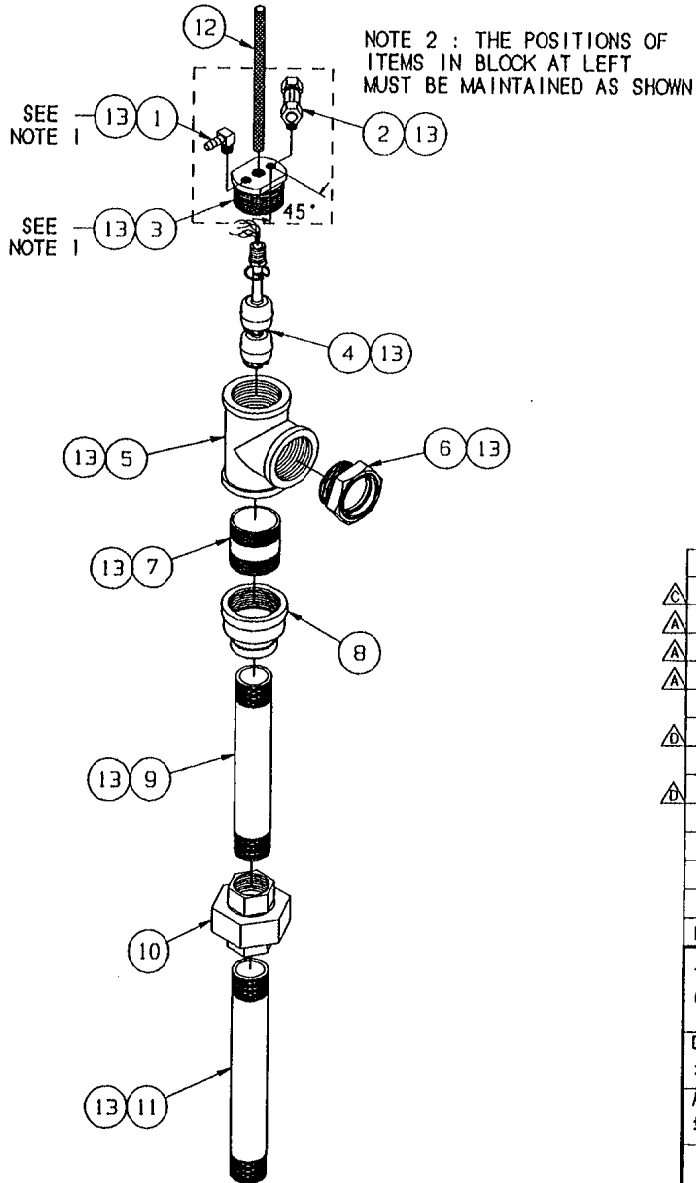

LET.	REVISIONS	DATE	BY
A	ADDED 14408, 14409, AND 21306 TO ASSEMBLY. REVISED PRIOR TO RELEASE.	4/7/94	DLD
B	CHANGED NOTE 1 (COMPRESSION TEE FITTING WAS HOSE BARB FITTING), EO C-2618.	5/18/94	DLD
C	ADDED 1070540800 PER EO C-2668	7/05/94	PJD
D	REPLACED 202211 WITH 20253 AND REPLACED 143821 WITH 14284. PER EO 4C-2718.	8/26/94	DLD

ITEM	QTY.	PART NO.	DESCRIPTION
13		A/R 00934	SEALANT, RECTORSEAL
△ 12	1	1070540800	SLEEVING, FIBERGLASS BRAID .330' ID X 8' LG
△ 11	1	14409	NIPPLE, 1 X 10, BLACK
△ 10	1	21306	UNION, 1", BLACK
△ 9	1	14408	NIPPLE, 1 X 9, BLACK
8	1	105763	COUPLING, REDUCER, 1-1/2" X 1", BLACK
△ 7	1	14294	NIPPLE, 1-1/2" X CLOSE, BRASS
6	1	105227	SIGHT WINDOW, 1-1/2 NPT, BRASS
△ 5	1	20253	TEE, 1-1/2" NPT, BRASS
4	1	105225	SWITCH, FLOAT, 3 SW. S/S
3	1	105224	FITTING, FLOAT ADAPTER 1-1/2 BRASS
2	1	06184	FITTING, COMP. TEE 3/8 T X 3/8 T X 1/8 NPT
1	1	105787	FITTING, HOSE BARB 1/4 H X 1/8 NPT, 90°

TOLERANCES (EXCEPT AS NOTED)		CLEVELAND RANGE INC. 1333 East 179th St. Cleveland, Ohio 44110-2574	
DECIMAL ± N/A	SCALE 1/4	DRAWN BY DUTCHMAN	APPROVED BY -
ANGULAR ± 1°	TITLE FLOAT ASSY., SC10 250,000 BTU		
CK	DATE 02-14-94	DWG. NO. B - 106690	REV. D

NOTE:
1.) FOR INSTALLATION OF CHECK VALVE
SEE INSTRUCTION DRAWING 260AKR

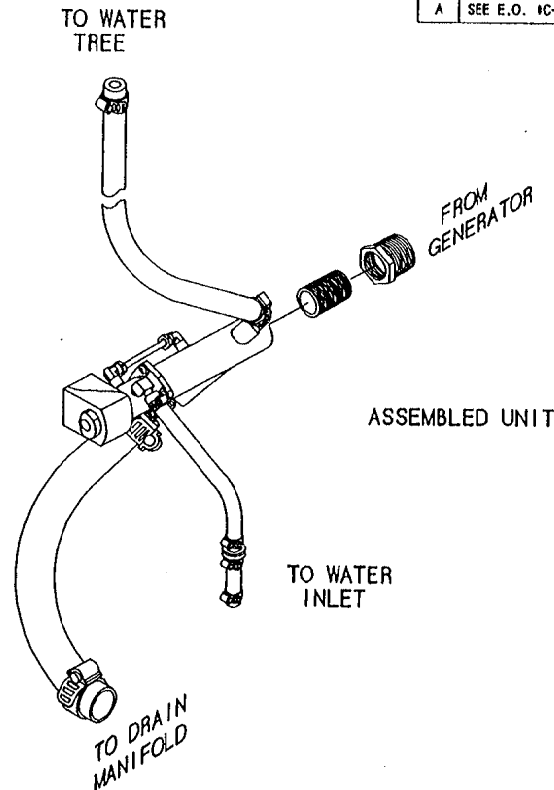
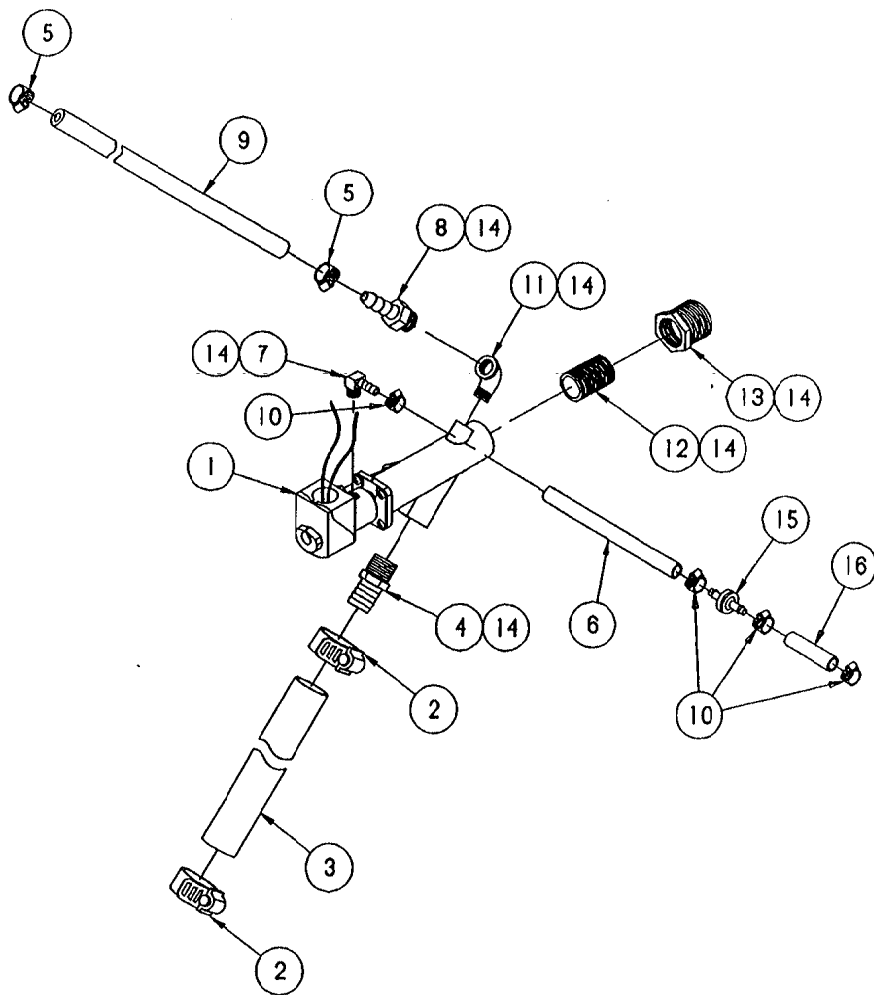

LET.	REVISIONS	DATE	BY
A	SEE E.O. 14-2668	07-05-94	PJD

ITEM	QTY.	PART NO.	DESCRIPTION
△ 16	1	1058500200	HOSE, NT-80 1/4 X 1/2 X 2' LG.
△ 15	1	107032	CHECK VALVE, PLASTIC DIAPHRAGM
REF.		14	A/R 00934 SEALANT, RECTORSEAL
REF.		13	- 02598 BUSHING, HEX, 1 X 3/4
REF.		12	- 14343 NIPPLE, 3/4 X CLOSE, BLACK
		11	1 05235 ELBOW, STREET, 90° X 1/4", BRASS
△ 10	4	108526	CLAMP, METAL, WORM DRIVE, 3/16 X 5/16
△ 9	1	1058494400	HOSE, NT-80, 1/2 X 3/4 X 44" LG.
△ 8	1	104048	FITTING, HOSE 1/2 H X 1/4 MPT, STR
7	1	105787	FITTING, HOSE 1/4 H X 1/8 MPT, 90°
△ 6	1	1058500600	HOSE, NT-80, 1/4 X 1/2 X 6" LG.
5	2	106219	CLAMP, METAL, WORM DRIVE, 1/4 X 25/32
4	1	06185	FITTING, HOSE BARB 3/4 MPT X 1" H, STR.
△ 3	1	1054690650	HOSE, EPDM, BLACK 1" ID X 6.5" LG.
2	2	03204	CLAMP, METAL, WORM DRIVE .812 X 1.300
1	1	22244	VALVE, DRAIN, PARKER

TOLERANCES (EXCEPT AS NOTED)			
CLEVELAND RANGE INC. 1333 East 179th St. Cleveland, Ohio 44110-2574			
DECIMAL ± N/A	SCALE 3/8=1	DRAWN BY DUTCHMAN	APPROVED BY
ANGULAR ± N/A	TITLE VALVE ASSEMBLY, DRAIN STEAMCRAFT 10, GAS, PRESSURE		
CK	DATE 02-14-94	DRAWING NO. C - 106687	REV. A

THIS DESIGN DESCRIBES A PROPRIETARY ITEM
AND IS THE PROPERTY OF CLEVELAND RANGE.
THIS DRAWING IS NOT TO BE COPIED OR USED
WITHOUT THE APPROVAL OF CLEVELAND RANGE.

LET.	REVISIONS	DATE	BY
A	REPLACED 06231 WITH 08192 AND ADDED 05237, SEE E.O. C-2618.	4/28/94	DLD
B	REPLACED 08237 WITH 08240, 22149 WITH 22119, 14324 WITH 14343, 05253 WITH 05259, ADD 100223 WITH 20211, ADDED 02598, SEE EO C-2610.	8/6/94	DLD

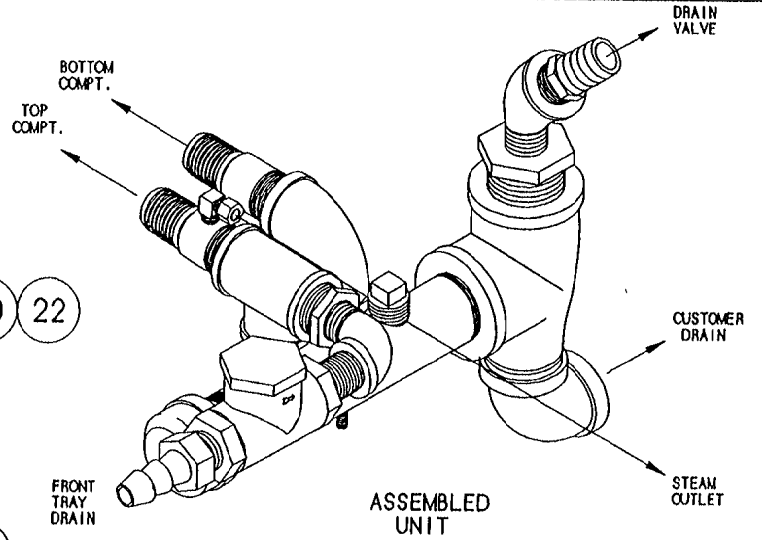
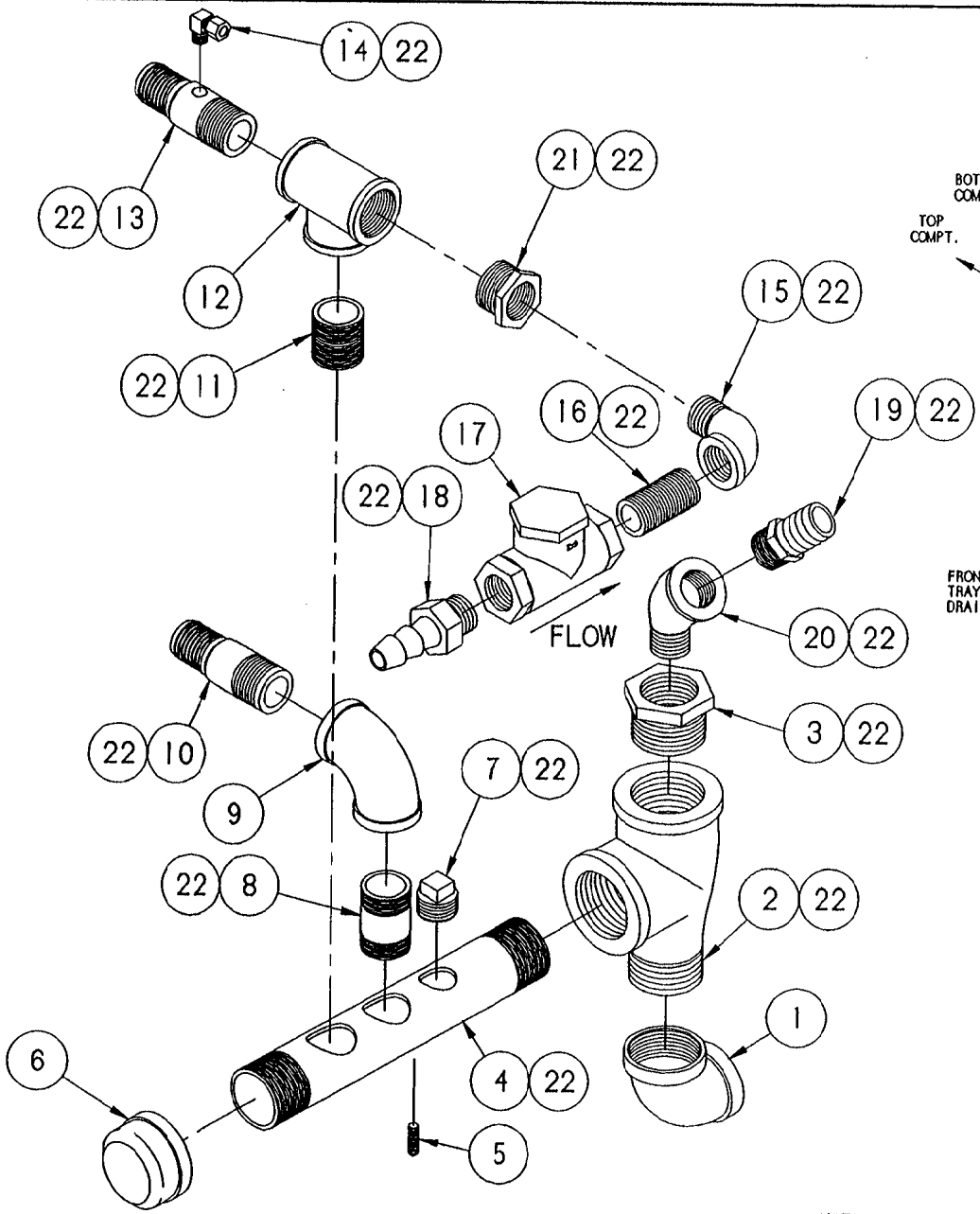

ITEM	QTY.	PART NO.	DESCRIPTION
22	A/R	00934	SEALANT, RECTORSEAL
21	1	02598	BUSHING, HEX, 1" X 3/4", BLACK
20	1	05237	ELBOW, 45°, STREET, 3/4", BLACK
19	1	08185	FITTING, HOSE 3/4" X 1" HOSE, BRASS
18	1	08240	FITTING, HOSE BARB 3/4" H X 3/4" MPT
17	1	22119	VALVE, CHECK, 3/4"
16	1	14343	NIPPLE, 3/4" X CLOSE, BLACK
15	1	05259	ELBOW, STREET, 3/4" X 90°, BLACK
14	1	06192	FITTING, COMP. 1/4" T X 1/8" MPT, 90°
13	1	585191	FITTING, HOSE-DRAIN MANIFOLD W/ 1/8" HOLE
12	1	20211	TEE, 1", BLACK
11	1	14369	NIPPLE, 1" X CLOSE, BLACK
10	1	14481	FITTING, HOSE BARB TO MPT 1" X 1"
9	1	05265	ELBOW, 1" X 90°
8	1	14372	NIPPLE, 1" X 2-1/2" LG.
7	1	16608	PLUG, SQUARE HEAD, 3/4", BLACK
6	1	03058	CAP, PIPE, 1-1/2" MALLEABLE IRON
5	1	19917	STUD, WELD 1/4"-20 X 7/8, S/S
4	1	13252	MANIFOLD, DRAIN 1-1/2" NPT, BLACK
3	1	02578	BUSHING, REDUCING, 1-1/2" X 3/4"
2	1	20220	TEE, MALE RUN, 1-1/2", BLACK
1	1	05238	ELBOW, 1-1/2" NPT X 90°, BLACK

SEE NOTE

THIS DESIGN DESCRIBES A PROPRIETARY ITEM AND IS THE PROPERTY OF CLEVELAND RANGE. THIS DRAWING IS NOT TO BE COPIED OR USED WITHOUT THE APPROVAL OF CLEVELAND RANGE.

NOTE:
SEE DRAWING 260AHV FOR
STUD LOCATION INSTRUCTIONS

TOLERANCES (EXCEPT AS NOTED)		CLEVELAND RANGE INC. 1333 East 179th St. Cleveland, Ohio 44110-2574	
DECIMAL ± N/A	SCALE 1/2" = 1"	DRAWN BY DUTCHMAN	APPROVED BY
ANGULAR ± N/A	TITLE DRAIN, MANIFOLD ASSEMBLY STEAMCRAFT 10, GAS, PRESSURE		
DATE 10-13-93	DRAWING NO. C - 106f	REV. B	

NOTE:
 REMOVE AND DISCARD PLASTIC TAIL PIECE;
 REPLACE WITH ITEM 2

LET.	REVISIONS	DATE	BY
------	-----------	------	----

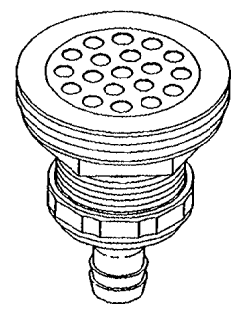
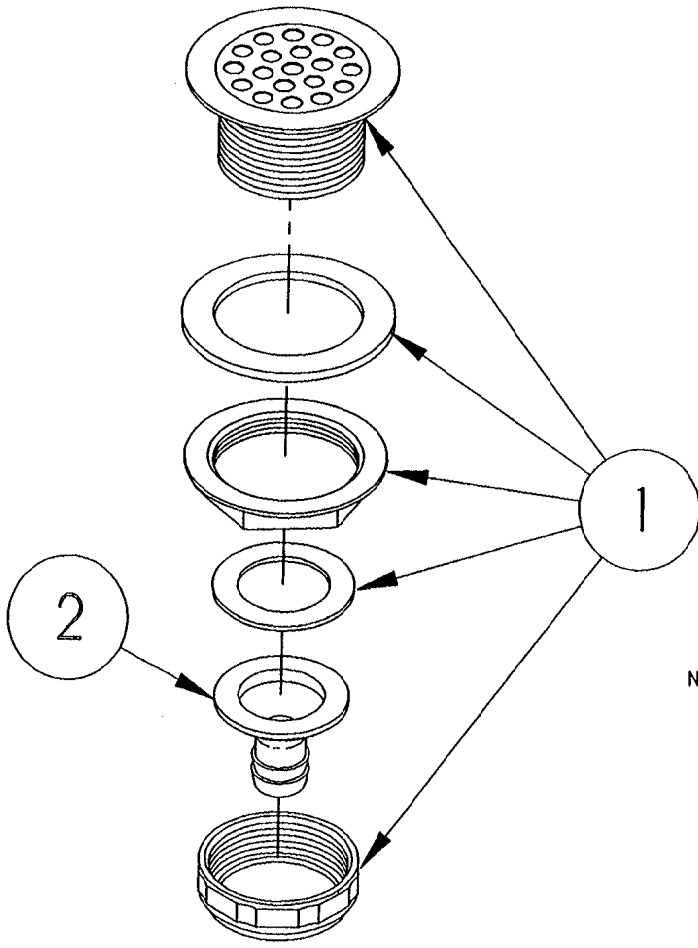

SEE
 NOTE

2	1	106736	TAIL PIECE, DRAIN	
1	1	105280	DRAIN, FITTING HOSE ADAPTER	
ITEM	QTY.	PART NO	DESCRIPTION	
TOLERANCES (EXCEPT AS NOTED)		CLEVELAND RANGE INC. 1333 East 179th St. Cleveland, Ohio 44110-2574		
DECIMAL ± N/A	SCALE 1/2"	DRAWN BY ATHERTON	APPROVED BY	
ANGULAR ± N/A	TITLE DRAIN ASSEMBLY TABLETOPS AND STEAMCRAFT 10			
CK	DATE 01-06-92	DRAWING NO. A-106737	REV. -	

THIS DESIGN DESCRIBES A PROPRIETARY ITEM
 AND IS THE PROPERTY OF CLEVELAND RANGE.
 THIS DRAWING IS NOT TO BE COPIED OR USED
 WITHOUT THE APPROVAL OF CLEVELAND RANGE.

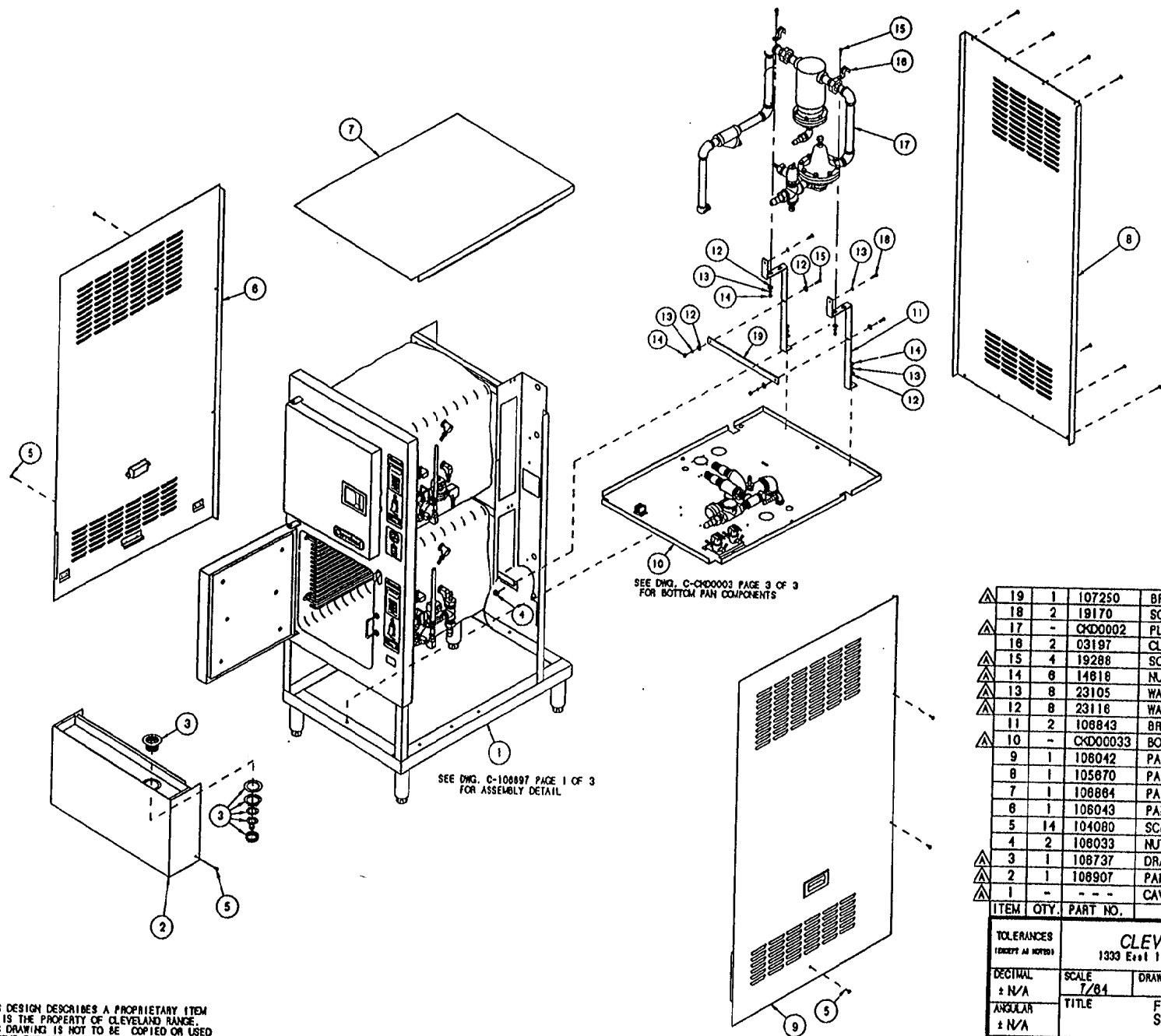

△	19	1	107250	BRACKET, SUPPORT, PLUMBING
	18	2	19170	SCREW, HEX, 1/4-20 X 5/8
△	17	-	CKD0002	PLUMBING, SC 10, DIRECT CONNECT
	16	2	03197	CLAMP, RIGID 3/4" HOLE
△	15	4	19288	SCREW, HEX, 1/4-20 X 3/4
△	14	8	14818	NUT, HEX 1/4-20
△	13	8	23105	WASHER, LOCK, 1/4"
△	12	8	23116	WASHER, FLAT 1/4 X 5/8 X .085
	11	2	108843	BRACKET, SUPPORT, SC 10 DC
△	10	-	CKD00033	BOTTOM PAN COMPONENTS ASSEMBLY
	9	1	108042	PANEL ASSY, SIDE, RIGHT, SC 10
	8	1	105670	PANEL, BACK, SC 10
	7	1	108864	PANEL, TOP, SC 10 ELECTRIC
	6	1	108043	PANEL ASSY, SIDE, LEFT, SC 10
	5	14	104080	SCREW, TRUSS HD, SHT. MET. #8 X 1/2
	4	2	108033	NUT, TINNEMAN
△	3	1	108737	DRAIN ASSY, TABLETOPS AND SC 10
△	2	1	108907	PANEL ASSY, LOWER FRONT, 4"
△	1	-	-	CAVITY ASSEMBLY WITH DOORS, SC 10
	ITEM	QTY.	PART NO.	DESCRIPTION

TOLERANCES
(EXCEPT AS NOTED)

CLEVELAND RANGE INC.
1333 East 179th St. Cleveland, Ohio 44110-2574

DECIMAL ± N/A	SCALE 7/84	DRAWN BY DUTCHMAN	APPROVED BY
ANGULAR ± N/A	TITLE FINAL ASSEMBLY, H.L. STEAMCRAFT POWER 10 DIRECT CONNECT		
CK	DATE 03-17-94	DRAWING NO. C - CKD0003	PAGE 2 OF 3 REV. A

THIS DESIGN DESCRIBES A PROPRIETARY ITEM AND IS THE PROPERTY OF CLEVELAND RANGE. THIS DRAWING IS NOT TO BE COPIED OR USED WITHOUT THE APPROVAL OF CLEVELAND RANGE.

STEAMCRAFT 10, PRESSURE - GAS MECHANICAL TIMER

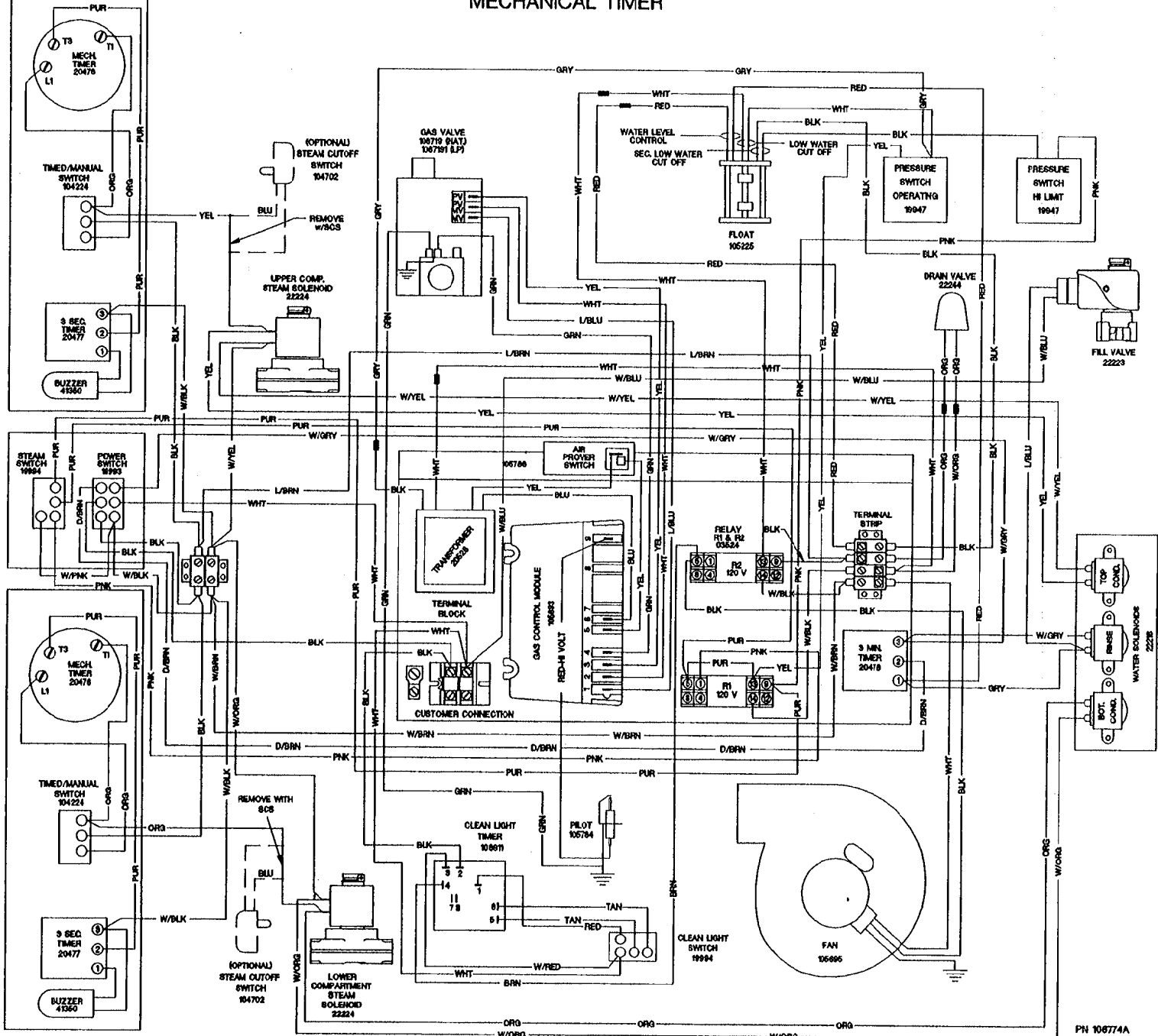

STEAMCRAFT 10, PRESSURE - GAS ON/OFF SWITCH

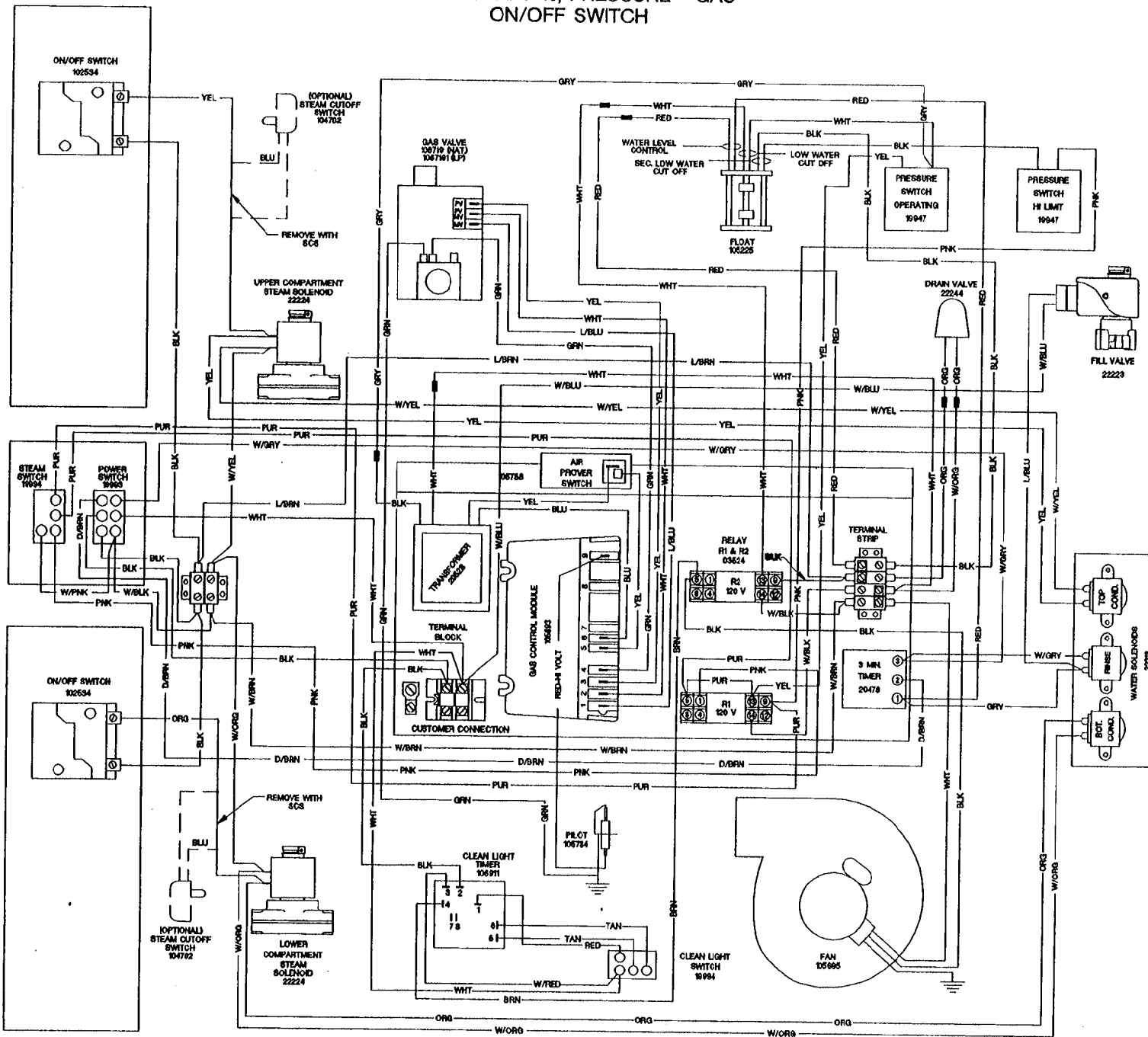

CLEVELAND RANGE
SEQUENCE OF OPERATIONS
24CGP10
Mechanical Timer

1. To turn the unit on, depress the red on/off rocker switch.
 - 115 VAC is sent to normally open blowdown valve closing it.
 - 115 VAC is sent to the Timed/Manual switches for the cabinets.
 - 115 VAC is sent to L1 and L2 of the water level board.

2. With the water level board energized and no water in the boiler
 - 115 VAC is sent from the IND terminal to the low water indicator light on the console.
 - 115 VAC is sent from the WF terminal to the fill solenoid after a 5-second delay.
 - The fill solenoid opens and the boiler fills.
 - The water fills to the secondary low water cutoff probe in the boiler, shorting it to ground
 - 115 VAC is removed from the IND terminal and the low water indicator light is de-energized.
 - 115 VAC is sent from the HTR terminal through the normally closed contact of the high-pressure switch to the amber reset switch,
 - 115 VAC is sent through the normally closed R1 contacts to energize the amber light.
 - If the low water cut off probe is not grounded for 20 seconds, 115 VAC is removed from HTR and sent back to IND energizing the low water light.

3. When the momentary amber switch is depressed 115 VAC is sent to the R1 relay closing it.
 - The normally closed R1 contacts open de-energizing the amber light.
 - The relay latches through the normally closed contacts of R1
 - If either the high-pressure switch (set at 15 PSI) or the low probe circuit on the water level board opens, then the latch circuit opens.
 - When the water level or pressure returns to a safe condition the amber light will energize and the process may begin again.

4. The R1 relay contacts close sending 115 VAC through the normally closed operating pressure switch to the 24 VAC transformer.
 - 24VAC is sent through the low water cutoff float switch to the R2 relay coil.
 - The normally open R2 contacts close and send 115 VAC to the fan.
 - The fan turns and the air prover switch is closed.
 - 24 VAC is sent through the air prover switch to the ignition module.
 - With 24 VAC to the ignition module 24VAC is sent to the pilot coil on the gas valve.
 - A spark is generated at the igniter.
 - The pilot valve is energized and opens.
 - Gas is sent to the pilot burner.
 - The gas is ignited and the flame rectifies the AC current.

- When the ignition module reads 1.0 micro amps DC current through the ground wire the coil to the main gas valve is energized
 - The pilot flame lights the main burner.
 - If the module does not read 1.0 micro amps DC in 90 seconds it will shut down the main burner and make one more try before locking out.
5. The water in the boiler is heated to steam.
 - As steam is generated and pressure builds the air is pushed out through the steamtrap on the lower steam manifold.
 - Steam goes through the steam trap heating it to 192 degrees closing the steam trap.
 6. Pressure builds in the boiler to the set point of 8-10 PSI.
 - The operating pressure switch opens and the heat circuit is de-energized.
 7. With the timed/manual switch in the timed position and time on the timer.
 - 115 VAC is sent to the steam solenoid and steam is sent to the cooking cabinet. There the steam is directed around the product.
 - 115 VAC is sent to the “Pause” or “Sure Cook” light.
 - 115 VAC is sent to the normally open contacts of the compartment thermostat.
 - The normally open contacts of the compartment thermostat close when the compartment temperature reaches 193 degrees
 - 115 VAC is sent to the timer motor and the timer begins to count down.
 - 115 VAC is sent to the condensate solenoid and cold water is sent to the condensate spray nozzle pulling the steam down the drain.
 - When the steam pressure drops below the operating set point the heat circuit is energized and the heat process begins again.
 8. Water continues to fill the boiler until the operational water float is lifted and closes, shorting the HI terminal on the water level board to the C terminal. .
 - When the HI terminal is shorted to the C terminal the WF terminal on the water level board is de-energized.
 - If the water level drops below the operational water float switch for more than 5 seconds the WF terminal is energized and the water fill circuit begins again.
 9. When the mechanical timer counts down:
 - 115 VAC is removed from the condensate circuit.
 - 115 VAC is removed from the steam solenoid.
 - 115 VAC is sent to the 3-second timer
 - 115 VAC is sent from the 3-second timer to the buzzer for 3 seconds.
 10. With the timed/manual switch in the Manual position
 - 115 VAC is sent to the steam solenoid and steam is sent to the cooking cabinet. There the steam is directed around the product.
 - 115 VAC is sent to the “Pause” or “Sure Cook” light.
 - 115 VAC is sent to the normally open contacts of the compartment thermostat.
 - The normally open contacts of the compartment thermostat close when the compartment temperature reaches 193 degrees

- 115 VAC is sent to the condensate solenoid and cold water is sent to the condensate spray nozzle pulling the steam down the drain.
- When the steam pressure drops below the operating set point the heat circuit is energized and the heat process begins again.

11. The unit is turned off by depressing the red rocker switch.

- 115 VAC is removed from the timing and heat circuits.
- 115 VAC is removed from the normally open blowdown valve allowing the unit to drain.
- 115 VAC is sent to the 3-minute timer.
 - The three-minute timer will energize the fill and rinse solenoids for 3 minutes while the steamer drains assisting and cooling the blowdown. .

STEAMCRAFT 10 PRESSURE, GAS - MECHANICAL TIMER

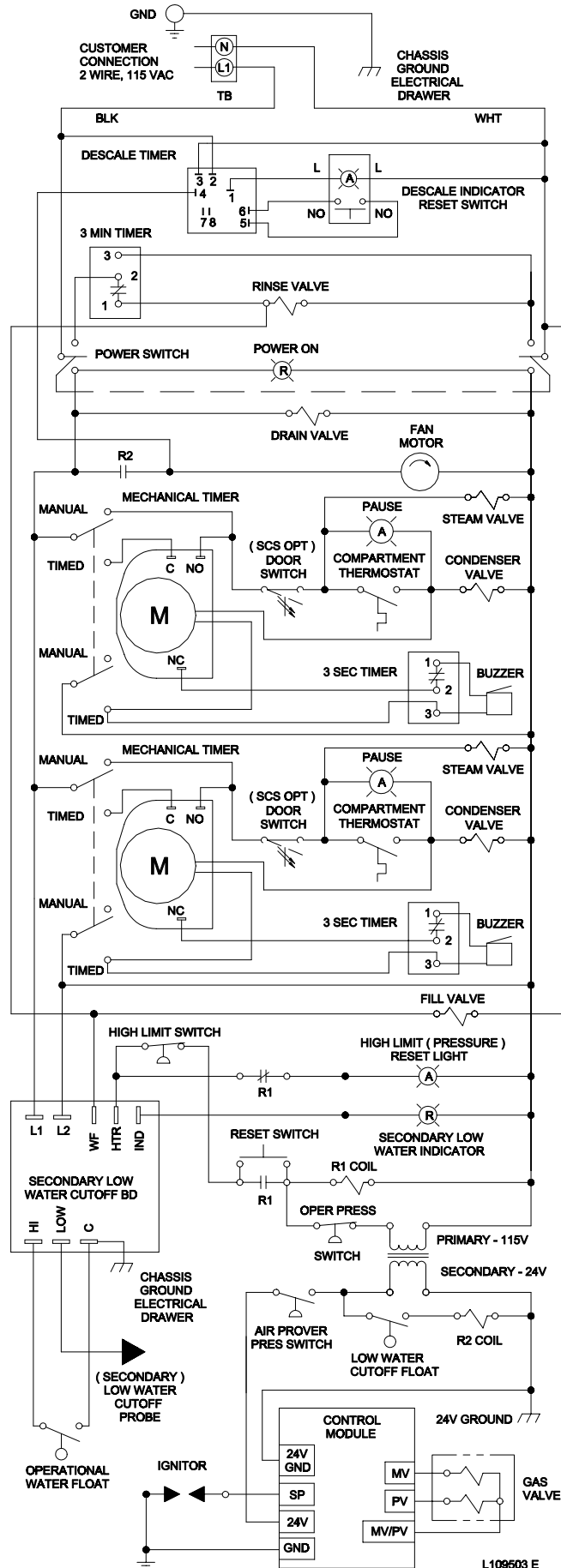

STEAMCRAFT 10 PRESSURE, GAS-MECHANICAL TIMER

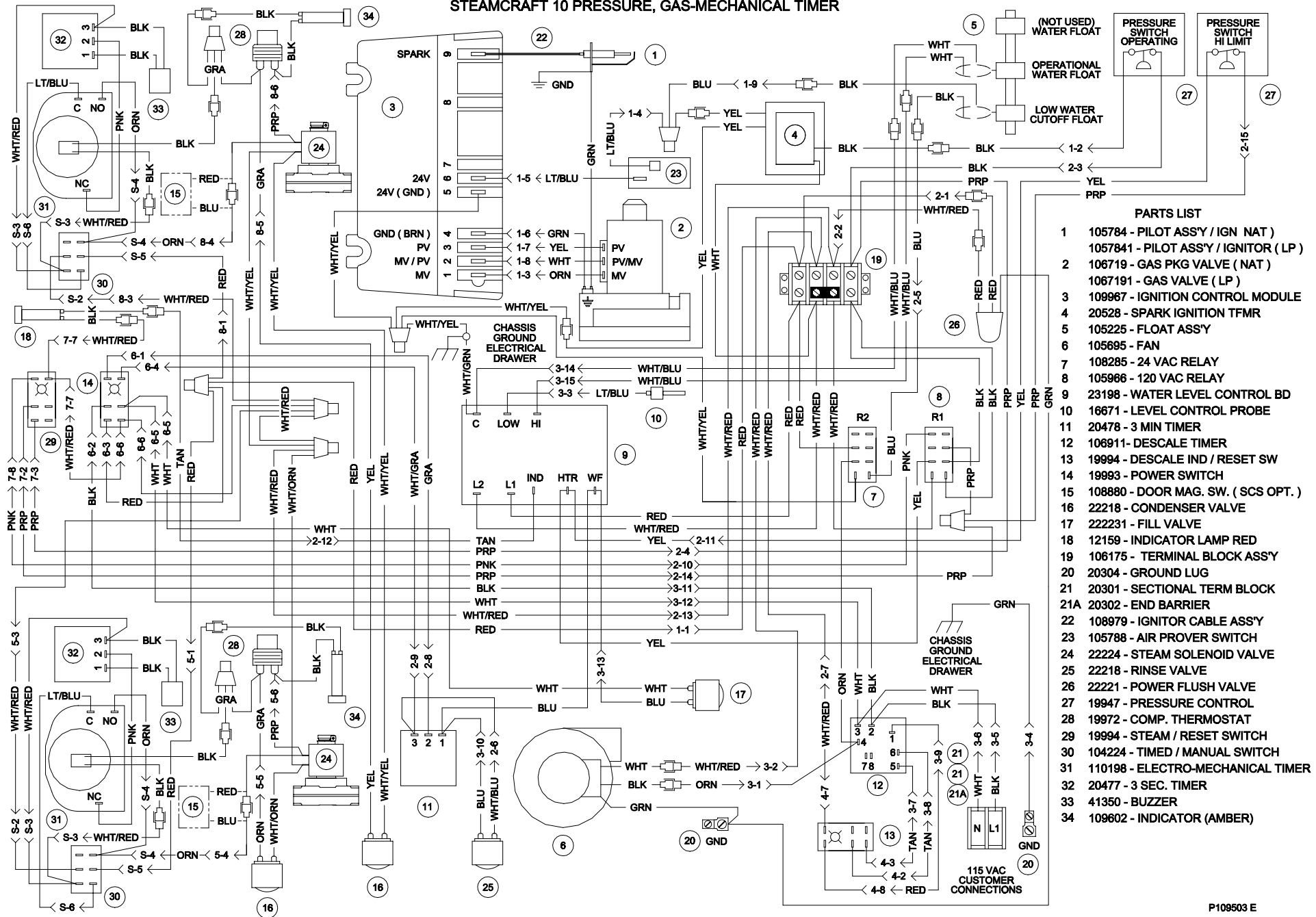

- PARTS LIST**
- 1 105784 - PILOT ASSY / IGN NAT)
1057841 - PILOT ASSY / IGNITOR (LP)
 - 2 106719 - GAS PKG VALVE (NAT)
1067191 - GAS VALVE (LP)
 - 3 109967 - IGNITION CONTROL MODULE
 - 4 20528 - SPARK IGNITION TFMR
 - 5 105225 - FLOAT ASS'Y
 - 6 105695 - FAN
 - 7 108285 - 24 VAC RELAY
 - 8 105966 - 120 VAC RELAY
 - 9 23198 - WATER LEVEL CONTROL BD
 - 10 16671 - LEVEL CONTROL PROBE
 - 11 20478 - 3 MIN TIMER
 - 12 106911- DESCALE TIMER
 - 13 19994 - DESCALE IND / RESET SW
 - 14 19993 - POWER SWITCH
 - 15 108880 - DOOR MAG. SW. (SCS OPT.)
 - 16 22218 - CONDENSER VALVE
 - 17 222231 - FILL VALVE
 - 18 12159 - INDICATOR LAMP RED
 - 19 106175 - TERMINAL BLOCK ASS'Y
 - 20 20304 - GROUND LUG
 - 21 20301 - SECTIONAL TERM BLOCK
 - 21A 20302 - END BARRIER
 - 22 108979 - IGNITOR CABLE ASS'Y
 - 23 105788 - AIR PROVER SWITCH
 - 24 22224 - STEAM SOLENOID VALVE
 - 25 22218 - RINSE VALVE
 - 26 22221 - POWER FLUSH VALVE
 - 27 19947 - PRESSURE CONTROL
 - 28 19972 - COMP. THERMOSTAT
 - 29 19994 - STEAM / RESET SWITCH
 - 30 104224 - TIMED / MANUAL SWITCH
 - 31 110198 - ELECTRO-MECHANICAL TIMER
 - 32 20477 - 3 SEC. TIMER
 - 33 41350 - BUZZER
 - 34 109602 - INDICATOR (AMBER)

CLEVELAND RANGE
SEQUENCE OF OPERATIONS
24 CGP 10
Electronic Timer

1. To turn the unit on, depress the red on/off rocker switch.
 - 115 VAC is sent to normally open blowdown valve closing it.
 - 115 VAC is sent to the 24 VAC transformer to the timer.
 - 24 VAC is sent to the timer.
 - 115 VAC is sent to the Timed/Manual switches for the cabinets.
 - 115 VAC is sent to L1 and L2 of the water level board.

2. With the water level board energized and no water in the boiler
 - 115 VAC is sent from the IND terminal to the low water indicator light on the console.
 - 115 VAC is sent from the WF terminal to the fill solenoid after a 5-second delay.
 - The fill solenoid opens and the boiler fills.
 - The water fills to the secondary low water cutoff probe in the boiler, shorting it to ground
 - 115 VAC is removed from the IND terminal and the low water indicator light is de-energized.
 - 115 VAC is sent from the HTR terminal through the normally closed contact of the high-pressure switch to the amber reset switch,
 - 115 VAC is sent through the normally closed R1 contacts to energize the amber light.
 - If the low water cut off probe is not grounded for 20 seconds, 115 VAC is removed from HTR and sent back to IND energizing the low water light.

3. When the momentary amber switch is depressed 115 VAC is sent to the R1 relay closing it.
 - The normally closed R1 contacts open de-energizing the amber light.
 - The relay latches through the normally closed contacts of R1
 - If either the high-pressure switch (set at 15 PSI) or the low probe circuit on the water level board opens, then the latch circuit opens.
 - When the water level or pressure returns to a safe condition the amber light will energize and the process may begin again.

4. The R1 relay contacts close sending 115 VAC through the normally closed operating pressure switch to the 24 VAC transformer.
 - 24VAC is sent through the low water cutoff float switch to the R2 relay coil.
 - The normally open R2 contacts close and send 115 VAC to the fan.
 - The fan turns and the air prover switch is closed.
 - 24 VAC is sent through the air prover switch to the ignition module.
 - With 24 VAC to the ignition module 24VAC is sent to the pilot coil on the gas valve.
 - A spark is generated at the igniter.
 - The pilot valve is energized and opens.

- Gas is sent to the pilot burner.
 - The gas is ignited and the flame rectifies the AC current.
 - When the ignition module reads 1.0 micro amps DC current through the ground wire the coil to the main gas valve is energized
 - The pilot flame lights the main burner.
 - If the module does not read 1.0 micro amps DC in 90 seconds it will shut down the main burner and make one more try before locking out.
5. The water in the boiler is heated to steam.
- As steam is generated and pressure builds the air is pushed out through the steamtrap on the lower steam manifold.
 - Steam goes through the steam trap heating it to 192 degrees closing the steam trap.
6. Pressure builds in the boiler to the set point of 8-10 PSI.
- The operating pressure switch opens and the heat circuit is de-energized.
7. With the timed/manual switch in the timed position (with time on the timer) or in the manual position:
- The timer display alternates between “PAUS” and the time set.
 - 115 VAC is sent to the steam solenoid and steam is sent to the cooking cabinet. There the steam is directed around the product and pulled down the drain by the condensate spray.
 - When the cooking compartment reaches 193 degrees internally the thermal switch closes and the timer begins to count down.
 - 115 VAC is sent to the condensate solenoid. The condensate solenoid sends cold water to the condensate spray nozzle pulling the steam down the drain.
 - When the pressure drops below the set point the heat circuit is energized and the heat process begins again.
8. Water continues to fill until the operational water float is lifted and closes, shorting the HI terminal on the water level board to the C terminal. .
- When the HI terminal is shorted to the C terminal the WF terminal on the water level board is de-energized.
 - If the water level drops below the operational water float switch for more than 5 seconds the WF terminal is energized and the water fill circuit begins again.
9. When the electronic timer counts down:
- 115 VAC is removed from the condensate circuit.
 - 115 VAC is removed from the steam solenoid
10. With the timed/manual switch in the manual position
- 115 VAC is sent to the steam solenoid and steam is sent to the cooking cabinet and around the product.
 - 115 VAC is sent to the normally open contacts of the compartment thermostat.

- The normally open contacts of the compartment thermostat close when the compartment reaches 193 degrees.
- 115 VAC is sent to the condensate solenoid and cold water is sent to the condensate spray nozzle pulling the steam down the drain.

11. The unit is turned off by depressing the red rocker switch.

- 115 VAC is removed from the timing and heat circuits.
- 115 VAC is removed from the normally open blowdown valve allowing the unit to drain.
- 115 VAC is sent to the 3-minute timer.
 - The three-minute timer will energize the fill and rinse solenoids for 3 minutes while the steamer drains assisting and cooling the blowdown. .

STEAMCRAFT 10 PRESSURE, GAS - ELECTRONIC TIMER

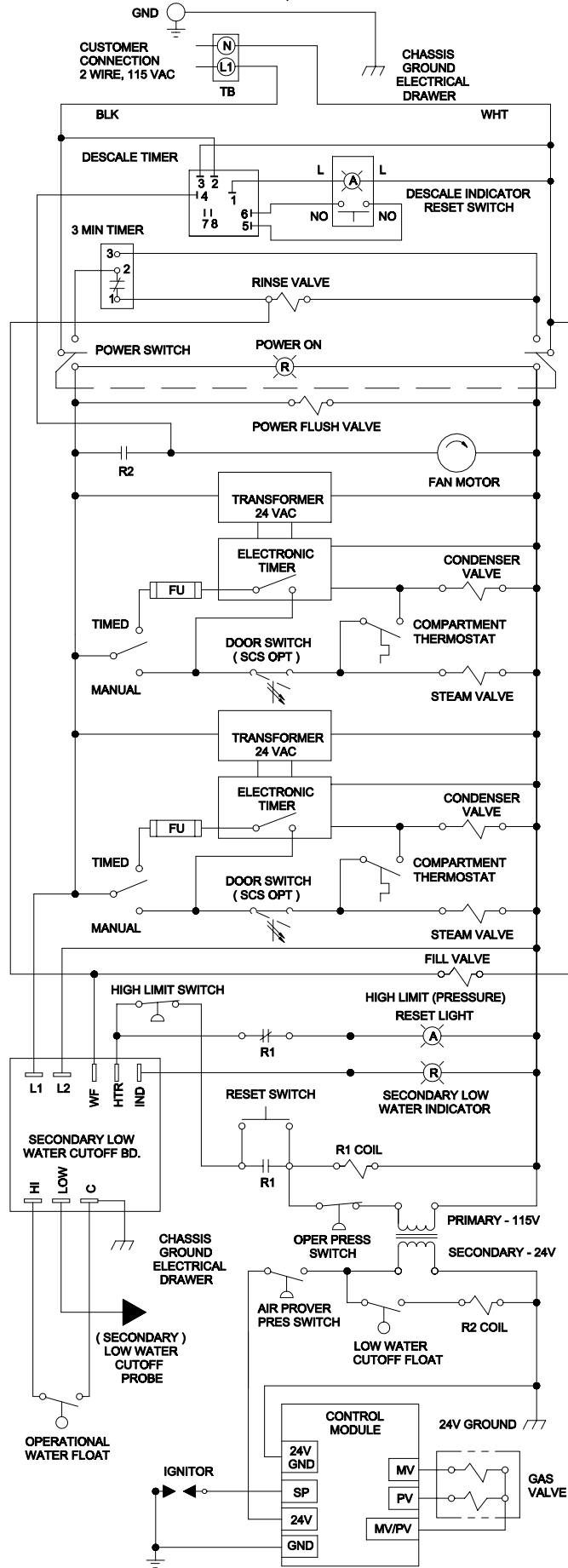

STEAMCRAFT 10 PRESSURE, GAS-ELECTRONIC TIMER

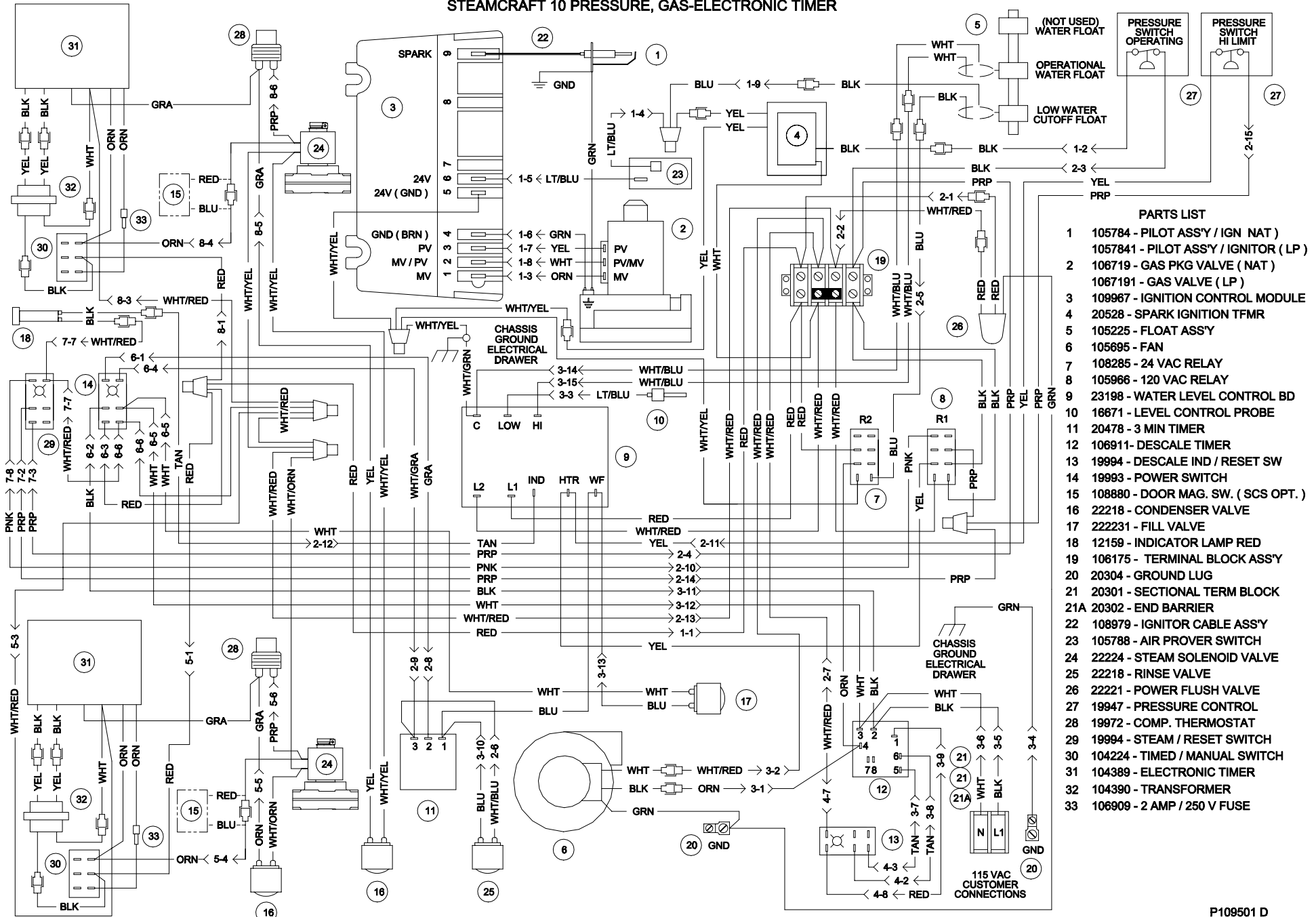

- ### PARTS LIST
- 1 105784 - PILOT ASSY / IGN NAT
 - 1057841 - PILOT ASSY / IGNITOR (LP)
 - 2 106719 - GAS PKG VALVE (NAT)
 - 1067191 - GAS VALVE (LP)
 - 3 109967 - IGNITION CONTROL MODULE
 - 4 20528 - SPARK IGNITION TFMR
 - 5 105225 - FLOAT ASSY
 - 6 105695 - FAN
 - 7 108285 - 24 VAC RELAY
 - 8 105966 - 120 VAC RELAY
 - 9 23198 - WATER LEVEL CONTROL BD
 - 10 16671 - LEVEL CONTROL PROBE
 - 11 20478 - 3 MIN TIMER
 - 12 106911-DESCALE TIMER
 - 13 19994 - DESCAL IND / RESET SW
 - 14 19993 - POWER SWITCH
 - 15 108880 - DOOR MAG. SW. (SCS OPT.)
 - 16 22218 - CONDENSER VALVE
 - 17 222231 - FILL VALVE
 - 18 12159 - INDICATOR LAMP RED
 - 19 106175 - TERMINAL BLOCK ASSY
 - 20 20304 - GROUND LUG
 - 21 20301 - SECTIONAL TERM BLOCK
 - 21A 20302 - END BARRIER
 - 22 108979 - IGNITOR CABLE ASSY
 - 23 105788 - AIR PROVER SWITCH
 - 24 22224 - STEAM SOLENOID VALVE
 - 25 22218 - RINSE VALVE
 - 26 22221 - POWER FLUSH VALVE
 - 27 19947 - PRESSURE CONTROL
 - 28 19972 - COMP. THERMOSTAT
 - 29 19994 - STEAM / RESET SWITCH
 - 30 104224 - TIMED / MANUAL SWITCH
 - 31 104389 - ELECTRONIC TIMER
 - 32 104390 - TRANSFORMER
 - 33 106909 - 2 AMP / 250 V FUSE

**PROBLEM:
24CGP10 Boiler
won't build
pressure**

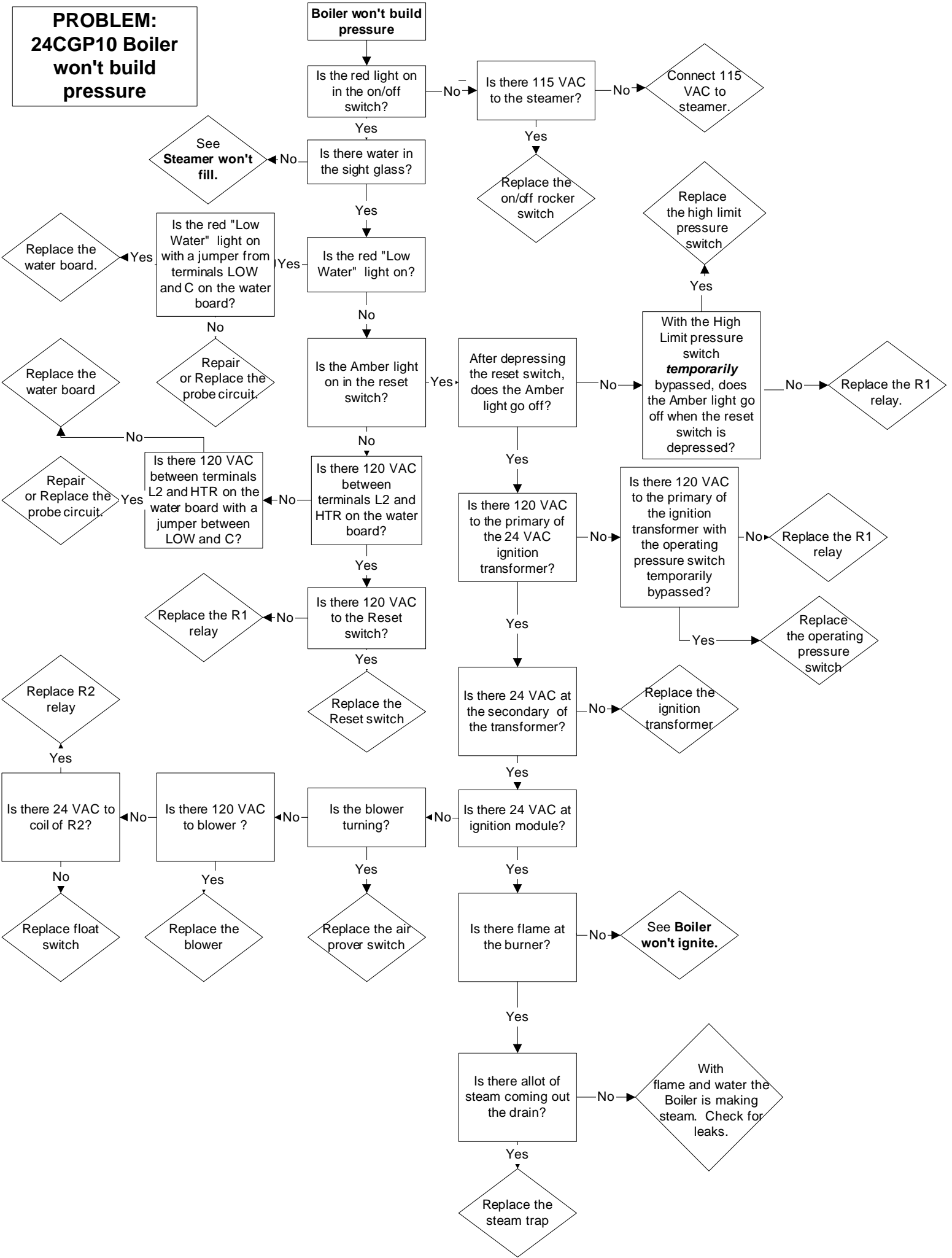

**PROBLEM:
24CGP10
Gas boiler
won't fill**

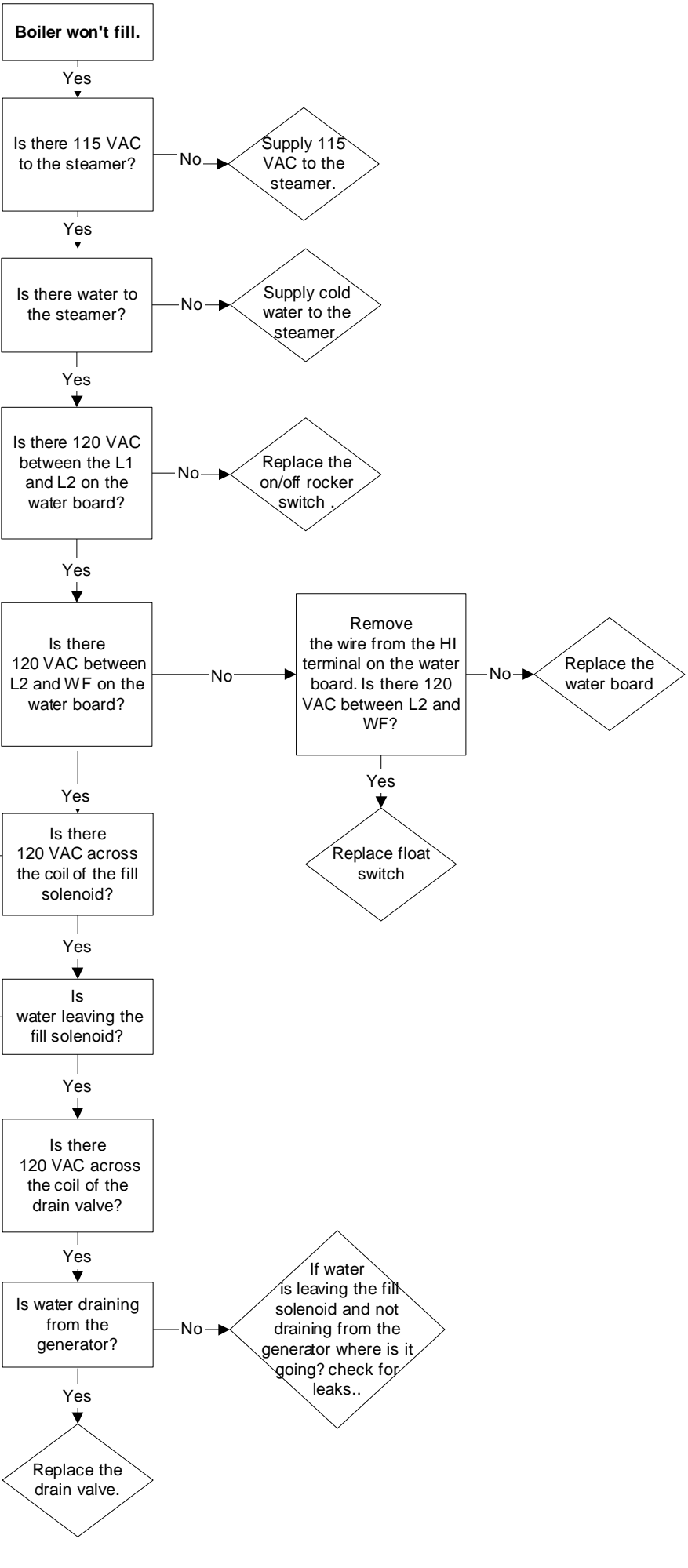

PROBLEM:
24CGP10
Gas boiler
won't ignite

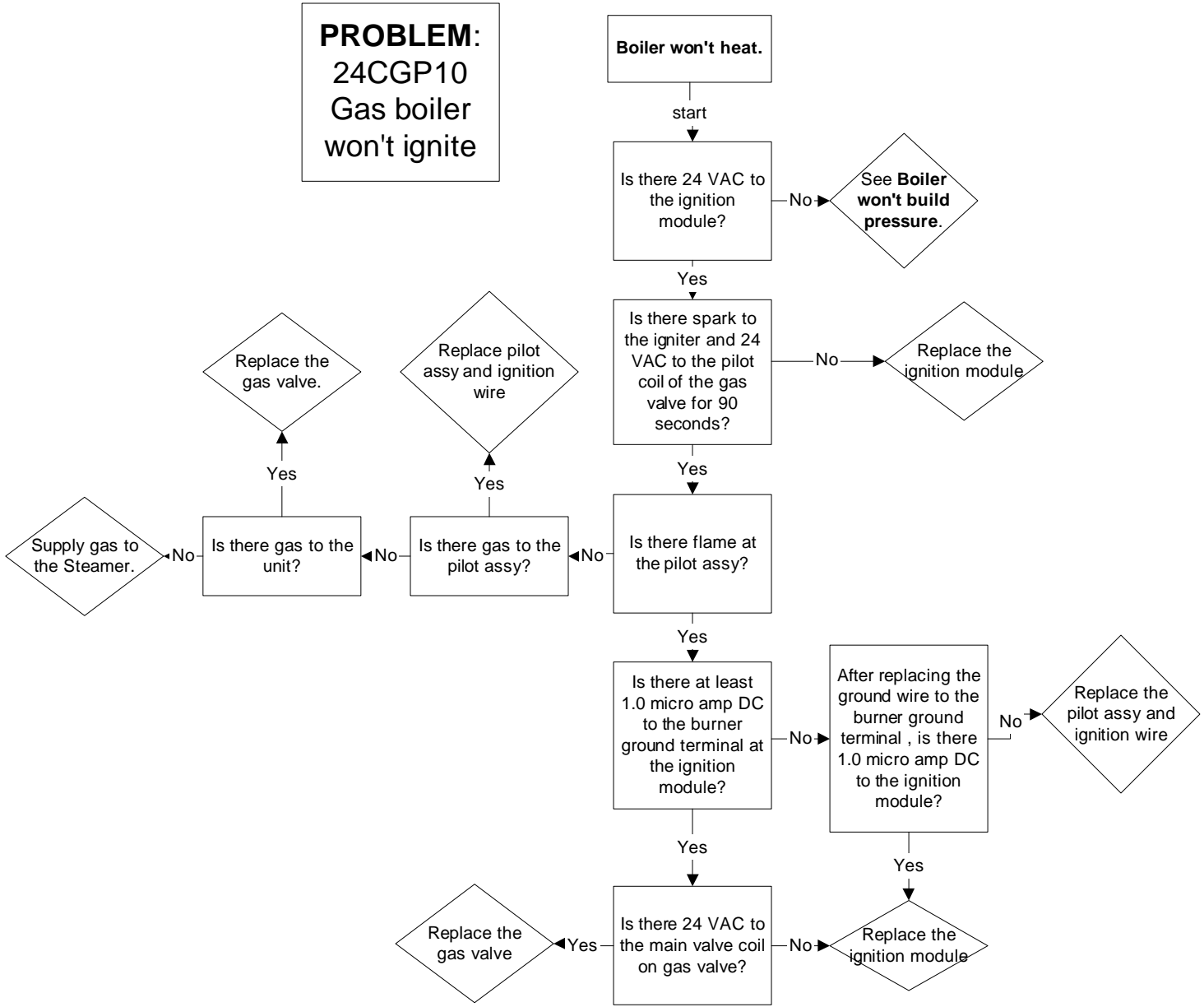

PROBLEM: 24CGP10 Gas Boiler Overfills

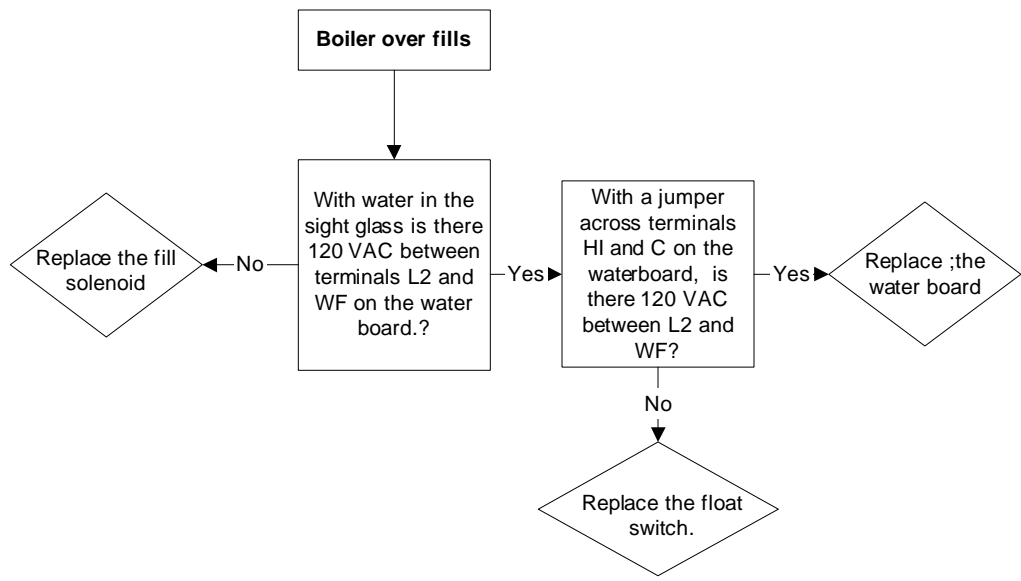

PROBLEM:
 24CGP10
 Gas Boiler Over
 Pressurizes
 (15# Safety
 valve opens)

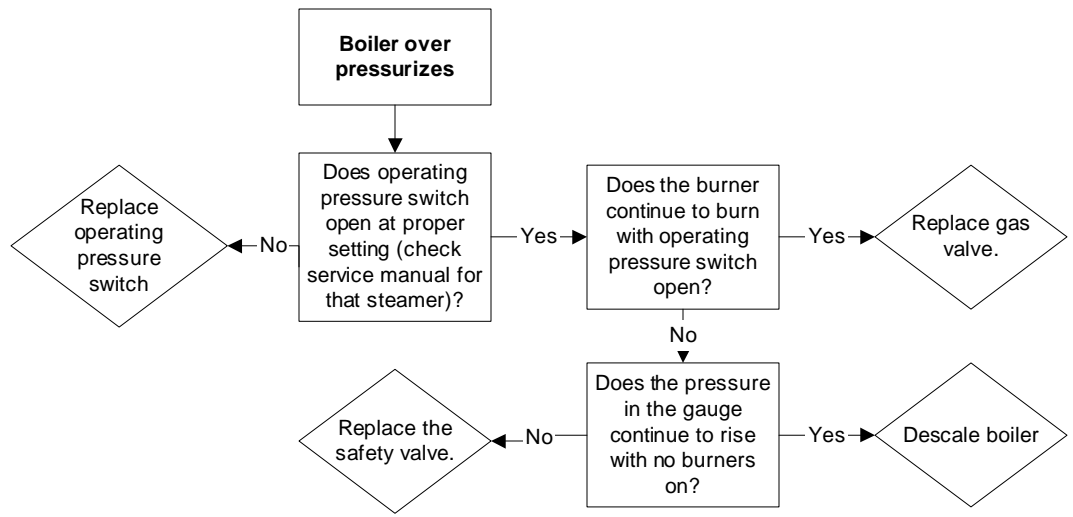

PROBLEM: 24CGP10 Stops Producing Steam

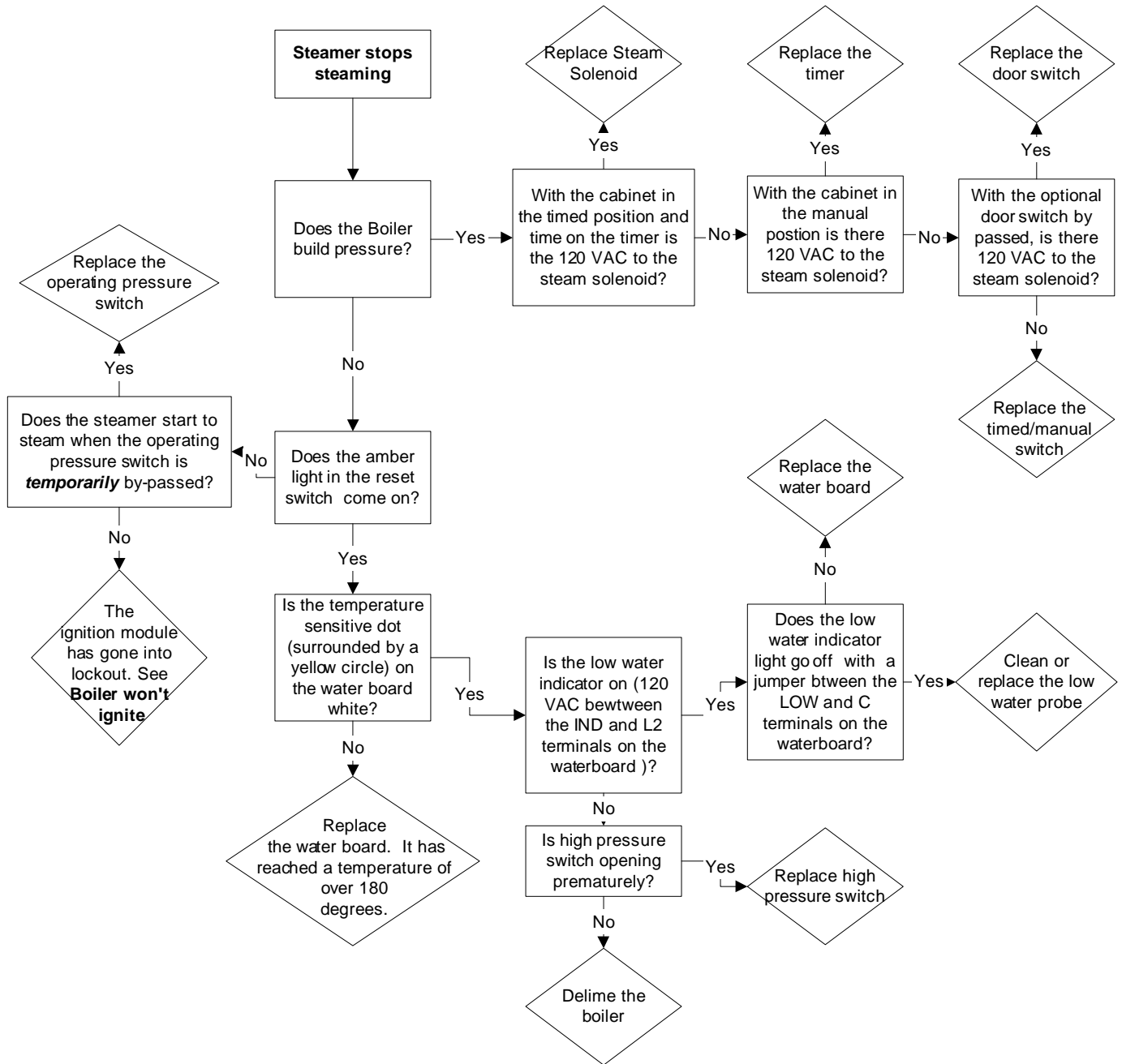

**PROBLEM:
24CGP10
Timer displays "PAUS" ("Sure Cook" light is on) and won't count down**

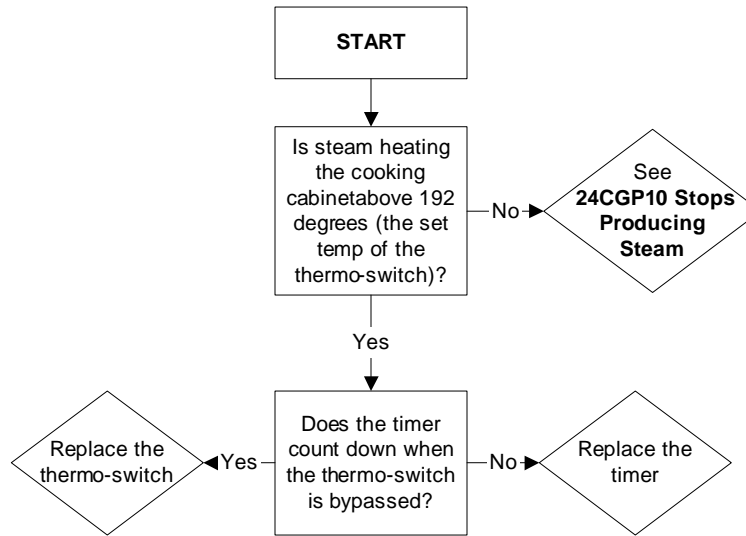

**PROBLEM:
24CGP10
Steam leaks around the door.**

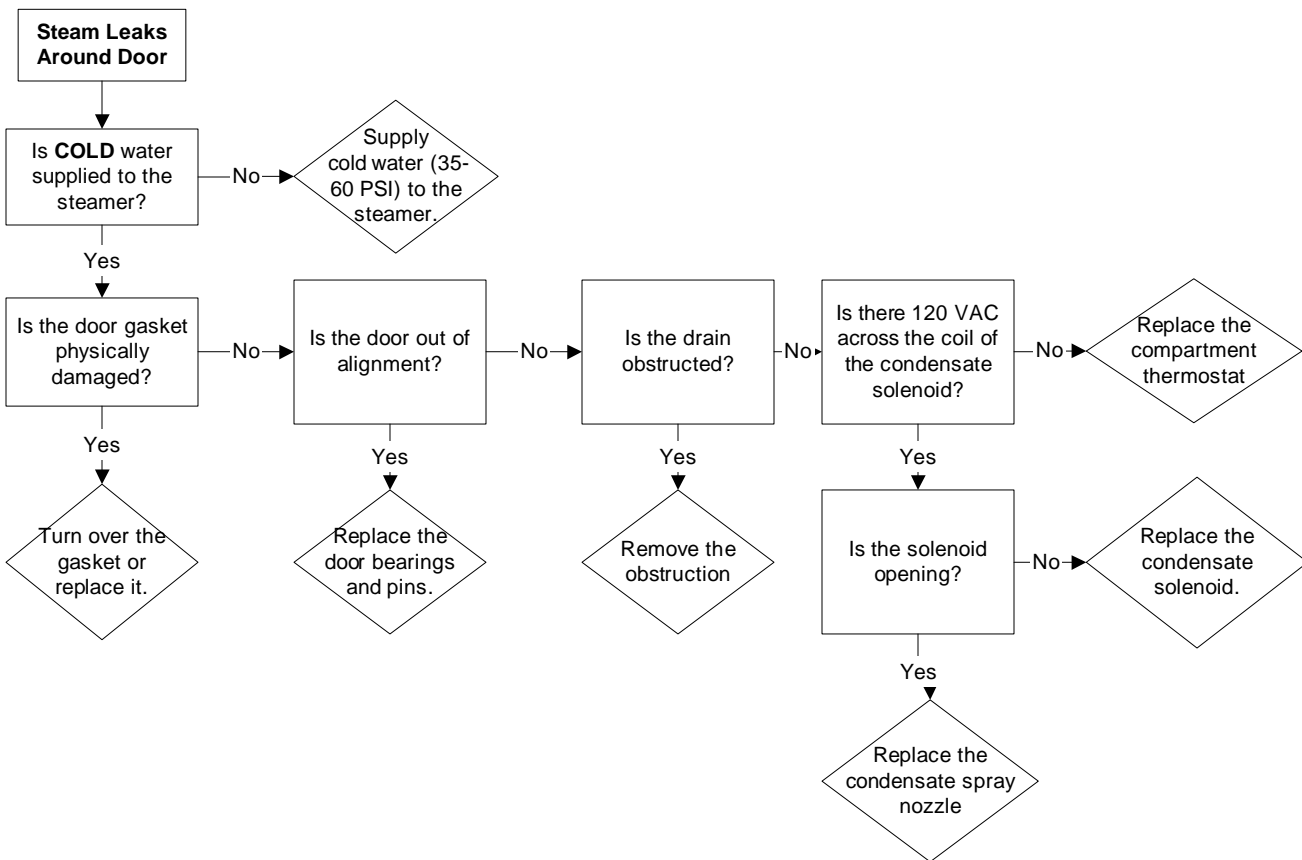

DESCALING INSTRUCTIONS

Steamcraft Power 10
uses Kit P/N: 107142

PRELIMINARY PROCEDURE

- 1) Start with the unit turned off & completely cool.
The boiler will drain for approximately 3 minutes.
- 2) Remove the lower front panel. There are 2 screws holding this panel in place.

GAS BOILER, ORIGINAL P10 (DETAIL "A")

- 1) Check that both ball valves are closed prior to removing the plug on both the inlet (left side) & outlet (right side) ports.
- 2) Attach the 3-inch nipples with attached unions to the inlet & outlet ports.
- 3) Install the 1/2 inch hose with the attached union to the inlet port.
- 4) Install the the 3/4 hose with the attached union to the outlet port.
- 5) Open the sliding view port on the right side panel of the unit. This will expose the float.
- 6) Fill the 5 gallon bucket with 2 gallons of descaler & 3 gallons of water.
- 7) Open the inlet & outlet ball valves attached to the unit. Turn the unit on.
- 8) Turn on the descaler pump & open the inlet valve to the boiler. Let the boiler fill with descaler just above the top of the float. This can be determined by watching the level rise in the float.

1333 East 179th Street
Cleveland, Ohio 44110

Phone: (216) 481- 4900
Fax: (216) 481- 3782



Part No. 260ALQ - E 4/03

9) As the descaler level in the bucket drops, add water so the pump remains submerged.

Note: Liquid level in the descaler bucket should not go below the pump.

10) When the descaler reaches the required level, open the exit valve. make sure the exit line is the bucket. The required level can be maintained by controlling the flow with the ball valves.

11) Let the pump operate for 1 hour.

12) After 1 hour, turn the pump off & close the inlet ball valve. Turn the main switch to off and let drain.

13) Flush the boiler with water when all of the descaler has drained.

14) Turn the unit on to fill with water.

-Fill the 5-gallon bucket with water.

-When the water level reaches the middle of the sight glass, turn on the pump & open the inlet valve.

-Make sure the outlet valve is closed.

15) Let the water level rise above the top of the float.

16) Open the outlet valve making sure the hose from the outlet valve is in the drain and not the bucket.

17) Continue flushing with water for 5 minutes.

Note: Additional water may have to be added to the bucket.

18) When flushing is complete, close the 2 ball valves attached to the unit and turn the unit off.

19) Replace the plugs in the ball valves & re-install the lower panel.

20) The unit is now ready for use.

GAS BOILER, CURRENT P10 (DETAIL "B")

1) Remove the plugs.

2) Attach the 3-inch nipples with attached unions to the inlet & outlet ports.

3) Install the 1/2 inch hose with the attached union to the inlet port.

4) Install the the 3/4 hose with the attached union to the outlet port.

5) Open the sliding view port on the right side panel of the unit. This will expose the float.

6) Fill the 5 gallon bucket with descaler.

7) Turn the unit on.

- 8) Turn on the descaler pump. Let the boiler fill with descaler just above the top of the float. This can be determined by watching the level rise in the float.
- 9) As the descaler level in the bucket drops, add water so the pump remains submerged.
Note: liquid level in the descaler bucket should not go below the pump.
- 10) When the descaler reaches the required level, make sure the exit line is in the bucket with the pump. The required level can be maintained by controlling the flow with the ball valves.
- 11) Let the pump run for 1 hour.
- 12) After 1 hour, turn the pump off. Also, turn the main switch to off and let drain.
- 13) Flush the boiler with water when all of the descaler has drained.
- 14) Turn the unit on to fill with water.
 - Fill the 5-gallon bucket with water.
 - When the water level reaches the middle of the sight glass, turn on the pump & open the inlet valve.
 - Make sure the outlet valve is closed.
- 15) Let the water level rise above the top of the float.
- 16) Open the outlet valve making sure the hose from the outlet valve is in the drain and not the bucket.
- 17) Continue flushing with water for 5 minutes.
Note: Additional water may have to be added to the bucket.
- 18) When flushing is complete, turn the unit off.
- 19) Replace the plugs & re-install the lower panel.
- 20) The unit is now ready for use.

REMOVE PLUGS BEFORE
INSTALLING BOILER KIT

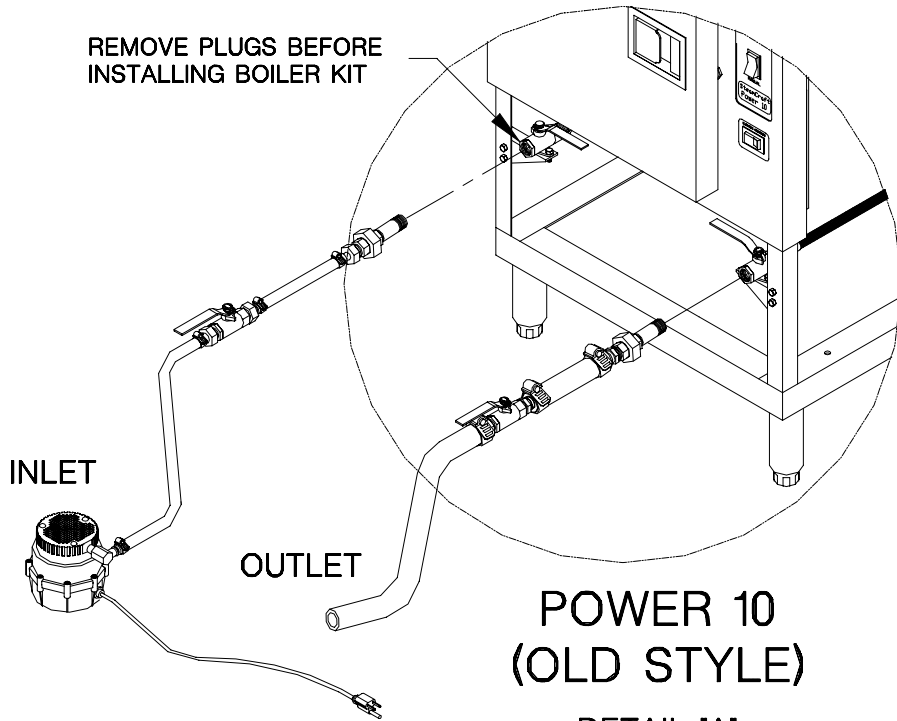

POWER 10 (OLD STYLE)

DETAIL 'A'

DESCALING KIT

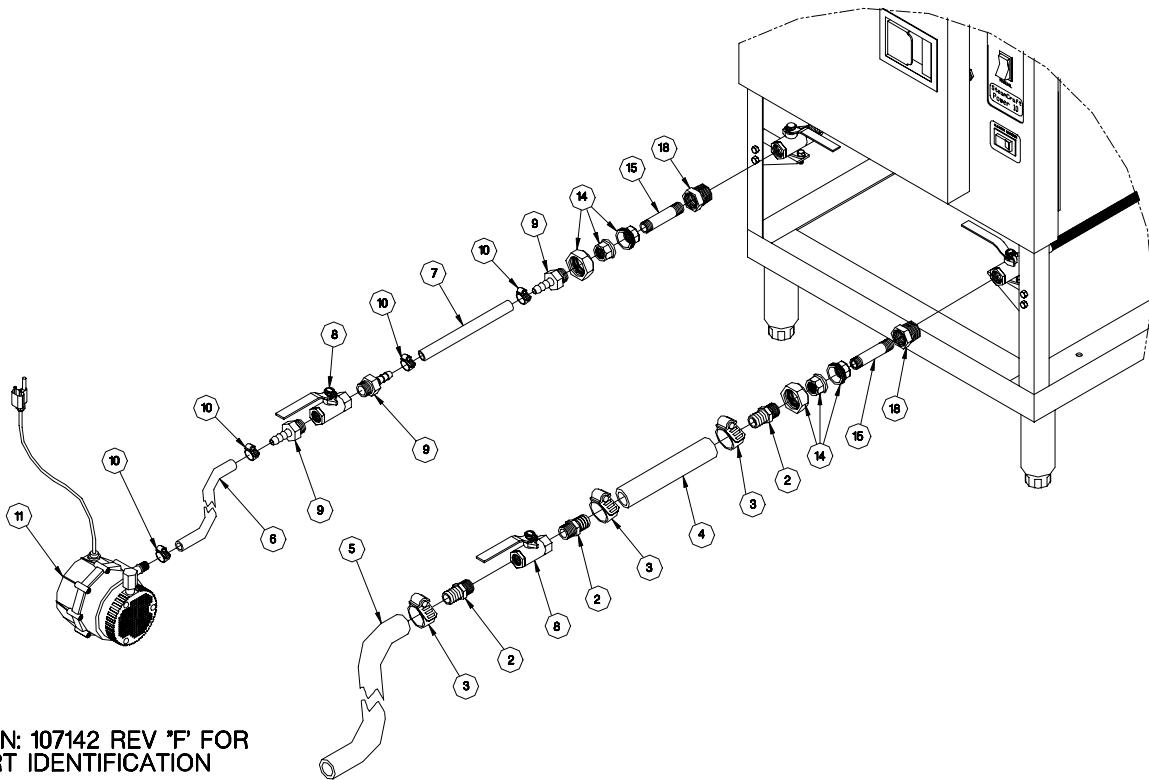

SEE P/N: 107142 REV 'F' FOR
PART IDENTIFICATION

REMOVE PLUGS BEFORE
INSTALLING BOILER KIT

INLET

OUTLET

POWER 10
(CURRENT)

DETAIL "B"

DESCALING KIT

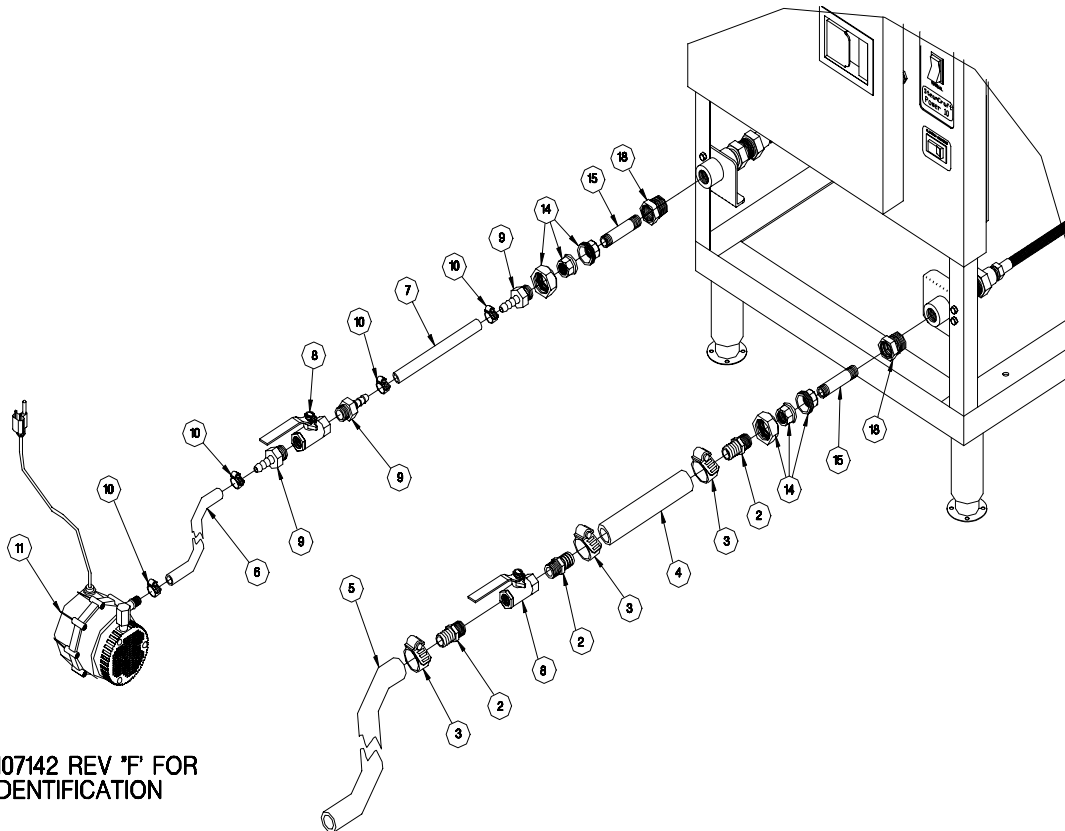

SEE P/N: 107142 REV 'F' FOR
PART IDENTIFICATION

STEAMCRAFT 10 DESCALING KIT PART LIST

(P/N: 107142)

ITEM	PART #	DESCRIPTION	QTY
1	437481	Plate Ass'y, Handhole w/Descaler Port	1
2	06241	Fitting, Hose Barb, 3/4 H x 1/2 MPT	3
3	03204	Clamp, Hose, Worm Drive	3
4	1088190600	3/4 Hose For Descaling Syst, 6.000" Lg	1
5	1088193600	3/4 Hose For Descaling Syst, 36.000" Lg	1
6	1088203600	1/2 Hose For Descaling Syst, 36.000" Lg	1
7	1088200600	1/2 Hose For Descaling Syst, 6.000" Lg	1
8	22212	Valve, Ball, 1/2 Female	2
9	06237	Fitting, Hose, Barb, 1/2H X 1/2 MPT	3
10	106219	Clamp, Hose Worm Drive	4
11	107131	Pump, Submersible, Boiler Descaler Kit	1
12	07106	Gasket, Handhole	1
13	107199	Bucket W/Lid, 5 Gallon	1
14	23103	Union, 0.500, Brass	2
15	14331	Nipple, 0.500 NPT x 2.500 Lg, Sch 40	2
16	108815	Label, Descaling System	1
17	108845	Envelope, Vinyl, 10" x 13", Short Side Opening	1
18	02566	Bushing, Reducing, 3/4 x 1/2	2
19	41943	Plate Ass'y, Mounting, Weldment	1
20	260 ALK	Instructions, Descaling Installation	1
21	260 ALP	Instructions, Piping Conversion	1