

Repair Manual

Pedestal Electric Self-Contained Kettle

Model KEP

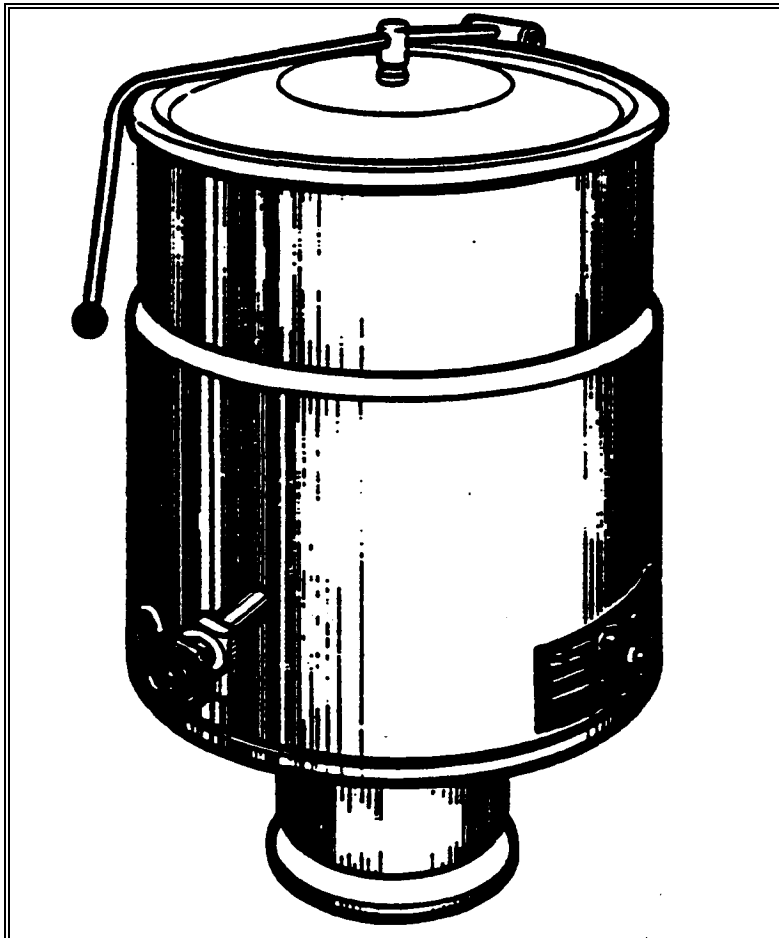

Cleveland Range, Inc.

UNITED STATES

1333 East 179th St., Cleveland, Ohio 44110

Phone: (216)481-4900 • Telex: 98-0546 • FAX: (216) 481-3782

CANADA

Garland Commercial Ranges

1177 Kamato Road

Mississauga, Ontario, Canada L4W7X4

Phone: (416) 624-0260 • FAX: (416) 624-0623

KET-13

Cleveland WARRANTY AND LIMITED EXTENDED WARRANTY COVERAGE

LIMITED WARRANTY

Cleveland Range products are warranted to the original purchaser to be free from defects in material and workmanship under normal use and service for the standard warranty period.

Cleveland Range agrees to repair or replace, at its option, f.o.b. factory, any pan which proves to be defective due to defects in material or workmanship during the warranty period, providing the equipment has been unaltered. and has been PROPERLY INSTALLED MAINTAINED, AND OPERATED IN ACCORDANCE WITH THE CLEVELAND RANGE OWNER'S MANUAL.

CLEVELAND RANGE agrees to pay any FACTORY AUTHORIZED EQUIPMENT SERVICE AGENCY (within the continental United States. Hawaii, and Canada) for reasonable labor required to repair or replace, at our option, f.o.b. factory, any part which proves to be defective due to defects in material or workmanship, during the labor warranty period. This warranty includes travel time not to exceed two hours and mileage not to exceed 50 miles (100 miles round-trip), but does not include post start-up, tightening loose fittings, minor adjustments, maintenance, cleaning or descaling.

The standard labor warranty allows factory payment of reasonable labor required to repair or replace such defective pans. Cleveland Range will not reimburse the expense of labor required for the repair or replacement of parts after the standard warranty period, unless an Extended Labor Warranty Contract has been purchased to cover the equipment for the balance of the warranty period from the date of equipment installation, start-up, or demonstration.

PROPER INSTALLATION IS THE RESPONSIBILITY OF THE DEALER. THE OWNER-USER, OR INSTALLING CONTRACTOR. AND IS NOT COVERED BY THIS WARRANTY. Many local codes exist, and it is the responsibility of the owner and installer to comply with these codes. Cleveland Range equipment is built to comply with applicable standards for manufacturers, including UL, A.G.A., NSF. ASME/Ntl. Bd., CSA. CGA, ETL. and others.

BOILER (Steam Generator) MAINTENANCE IS THE RESPONSIBILITY OF THE OWNER-USER. AND IS NOT COVERED BY THIS WARRANTY The use of good quality feed water is the responsibility of the Owner-User (see *Water Quality Requirements below*). THE USE OF POOR QUALITY FEED WATER *WILL VOID* EQUIPMENT WARRANTIES. Boiler maintenance supplies, including boiler hand gaskets, are not warranted beyond the first 90 days after the date the equipment is placed into service if no preventive maintenance records are available showing descaling every 90-120 days.

WATER QUALITY REQUIREMENTS

TOTAL DISSOLVED SOLIDS	less than 60 parts per million
TOTAL ALKALINITY	less than 20 parts per million
SILICA	less than 13 parts per million
CHLORIDE	less than 30 parts per million
pH FACTOR	greater than 75

The foregoing shall constitute the sole and exclusive remedy of original purchaser and the fun liability of Cleveland Range for any breach of warranty. THE FOREGOING IS EXCLUSIVE AND IN LIEU OF ALL OTHER WARRANTIES. WHETHER WRITTEN. ORAL, OR IMPLIED. INCLUDING ANY WARRANTY OF PERFORMANCE. MERCHANTABILITY, OR FITNESS FOR PURPOSE, AND SUPERSEDES AND EXCLUDES ANY ORAL WARRANTIES OR REPRESENTATIONS. OR WRITTEN WARRANTIES OR REPRESENTATIONS. NOT EXPRESSLY DESIGNATED IN WRITING AS A "WARRANTY" OR "GUARANTEE" OF CLEVELAND RANGE MADE OR IMPLIED IN ANY MANUAL. LITERATURE. ADVERTISING BROCHURE OR OTHER MATERIALS.

Cleveland Range's liability on any claim of any kind. including negligence, with respect to the goods or services covered here under. shall in no case exceed the price of the goods or services, or part thereof, which gives rise to the claim. IN NO EVENT SHALL CLEVELAND RANGE BE LIABLE FOR SPECIAL, INCIDENTAL. OR CONSEQUENTIAL DAMAGES. OR ANY DAMAGES IN THE NATURE OF PENALTIES.

LIMITED EXTENDED WARRANTY COVERAGE

The purchase of a Limited Extended Warranty Contract extends the standard warranty coverage to the purchased period of time (one to four years) from the date of installation, start-up, or demonstration, whichever is sooner.

MODEL KEP OPERATING CONTROLS AND INDICATORS

For your better understanding and confidence, the following explanation of the control system used on this kettle is offered.

Item No.	Description	Function
7	On-Off Toggle Switch (Kettle Bottom Dwg.)	Controls electrical power to the kettle.
2	Solid State Temperature Control (Control System Dwg.)	This control allows the operator to select kettle heat increments from Min. to Max. (see temperature setting chart in the operating instructions section of this manual).
8	Heat Indicator Light (Green) (Kettle Bottom Dwg.)	When lit, indicates that the kettle heating elements are on. Cycles On-Off with thermostat control.
12	Low Water Indicator Light (Red) (Kettle Bottom Dwg.)	When lit, indicates that the heating elements have cut out and the unit requires more water. (See Reservoir Fill procedure).
14	Vacuum/Pressure Guage (Kettle Bottom Dwg.)	Indicates steam pressure in PSI inside the steam jacket as well as vacuum in inches of mercury.
5	Pressure Relief Valve (Kettle Bottom Dwg.)	In the unlikely event that there is an excess steam build-up in the jacket, this valve opens automatically to relieve this pressure.
2	Chrome Plated Brass Vent (Kettle Bottom Dwg.)	This is used to vent the kettle if there is insufficient vacuum as well as for refilling the kettle with water. (See Venting Instruction and Reservoir Fill Procedures).
1-7	Draw-Off Valve (Draw-Off Valve Dwg.)	This valve is used to empty the kettle of either food product or wash water. It is supplied as standard equipment on Stationary models and is optional on Tilting kettles.
	Service Cover (Not Shown)	Located at the front of kettle support column. Remove this cover for easy access to contactors, kettle control box etc.

MODEL KEP KETTLE BOTTOM

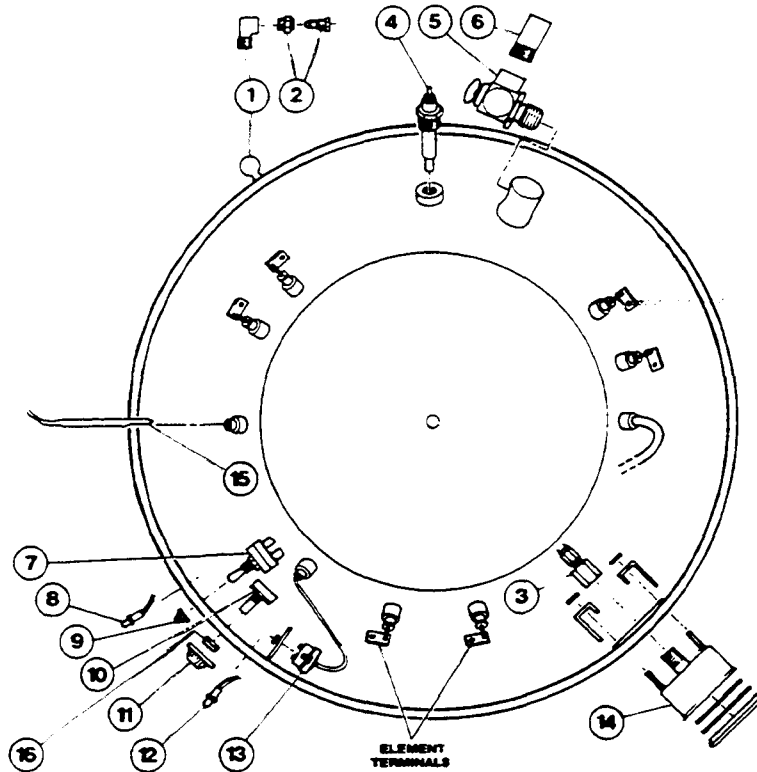

Item No.	Part No.	Description	Qty.
1	FI05025	Bleed Vent Elbow	1
2	KE50570	Bleed Vent Nut	1
3	FI05022	Connector	1
4	KE50556	Probe - Low Water	1
5	KE50998	Safety Valve 55 PSI.	1
6	KE50997	Blow Down Tube	1
7	KE50504	Toggle Switch	1
8	KE50568	L.E.D. Green	1
9	SK50062	Rubber Boot	1
10	KE50988	Potentiometer	1
11	KE50569	Knob	1
12	KE50567	L.E.D. Red	1
13	KE50558	Safety Thermostat	1
14	KE50429	Pressure Gauge	1
15	KE00515	Thermistor	1
16	KE51005	Rotary Seal	1

Use only replacement parts which are factory supplied as to preserve the certification of Underwriters Laboratories, American Gas Association, Canadian Standards Association or Canadian Gas Association (as applicable). The use of other than factory supplied replacement parts will void the warranty.

MODEL KEP CONTROL SYSTEM

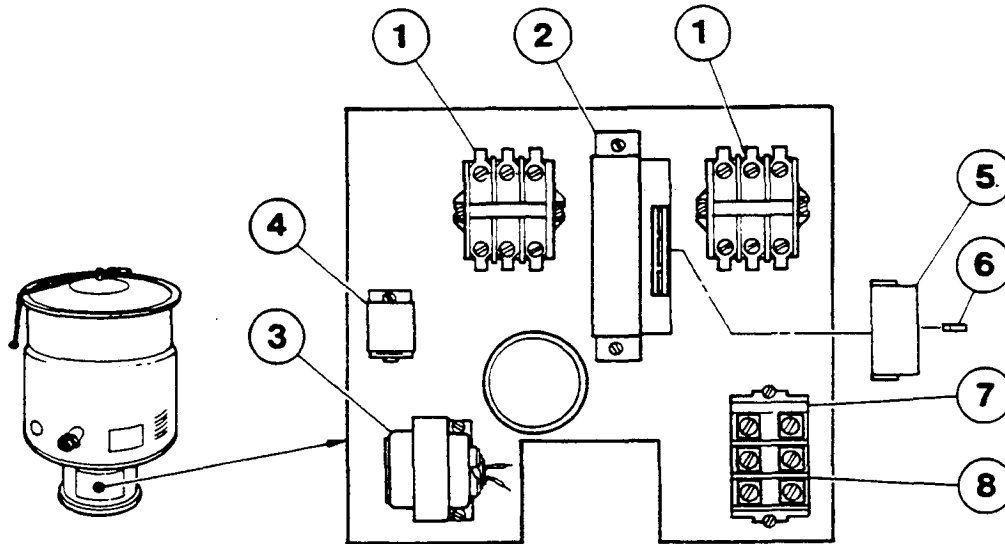

Item No.	Part No.	Description	Qty.
1	KE51322	Contactors (Furnas)	2
2	KE00458	Kettle Control Box	1
3	KE50752	Transformer	1
4	KE50753	Relay	1
5	KE51225	Edge Connector	1
6	KE51226	Connector Pin	1
7	KE50376	Terminal Block - End Section	1
8	KE50377	Terminal Block Section	3

Use only replacement parts which are factory supplied as to preserve the certification of Underwriters Laboratories, American Gas Association, Canadian Standards Association or Canadian Gas Association (as applicable). The use of other than factory supplied replacement parts will void the warranty.

HINGE ASSEMBLY FOR ALL KETTLES WITH HINGED LIDS

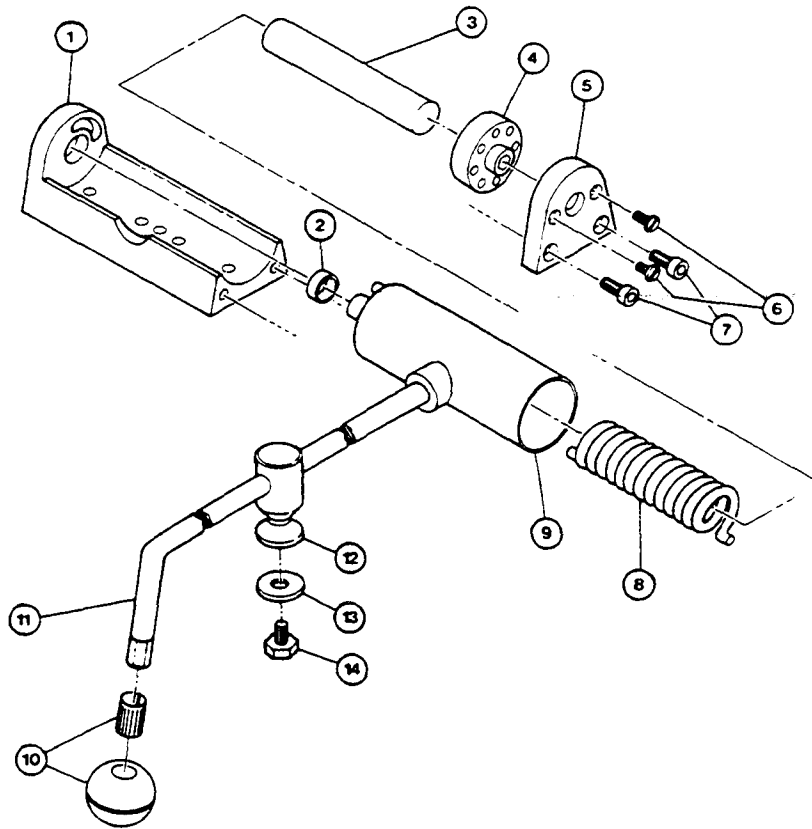

Item No.	Part No.	Description	Qty.
1-9	KE00598	Hinge Assembly	1
1	KE50822	Body Spring Assist Hinge	1
2	KE50824	Hinge Bearing	1
3	KE50823	Pin(Hinge)	1
4	KE50820	Insert Brass Adjust	1
5	KE50819	End Piece	1
6	FA11507	Screws Adjust	2
7	FA11284	Bolts End Block	2
8	KE50122	Spring (40 gal. and under)	1
	KE50121	Spring (60 gal. and over)	1
9	KE50821	Cylinder	1
10	KE50151	Knob Ball Type	1
11		Cover Handle (Specify Model)	1
12	KE00095	Lid Holder	1
13	FA30500	Washer Lid Holder	1
14	FA11223	Bolt Lid Holder	1

Use only replacement parts which are factory supplied as to preserve the certification of Underwriters Laboratories, American Gas Association. Canadian Standards Association or Canadian Gas Association (as applicable). The use of other than factory supplied replacement parts will void the warranty.

ALL KETTLES PARTS LIST - DRAW-OFF VALVE

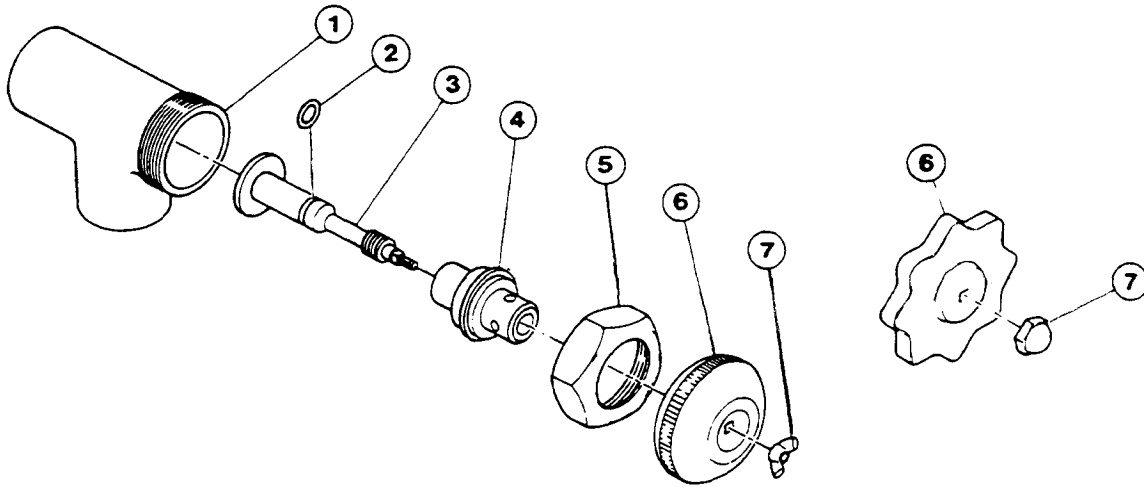

Item No.	Part No.	Description	Qty.
1-7	KE50219	1 1/2" Draw-off Valve Assy.	1
	KE50972	2" Draw-off Valve Assy.	1
	KE50973	3" Draw-off Valve Assy.	1
1		Body (1 1/2") (N/A, Please order Hem no. 1-7, Pan no. KE50219)	1
		Body (2") (N/A, Please order Item no. 1 -7, Part no. KE50972)	1
		Body (3") (N/A, Please order Item no. 1-7, Pan no. KE50973)	1
2	FA00111	"O"Ring(1 1/2",2")	1
	FA00210	"O" Ring (3")	1
3	SE50008	Stem (1 1/2")	1
	SE50009	Stem (2")	1
	SE50010	Stem (3")	1
4	SE50011	Bonnet (1 1/2")	1
	SE50012	Bonnet (2")	1
	SE50013	Bonnet (3")	1
5	SE50014	Hex Nut (1 1/2")	1
	SE50015	Hex Nut (2")	1
	SE50016	Hex Nut (3")	1
6	SE50017	Knob(1 1/2",2")	1
	SE50018	Knob(3")	1
7	SE50019	WingNut(1 1/2",2")	1
	SE50063	Acorn Nut (3")	1

Use only replacement parts which are factory supplied as to preserve the certification of Underwriters Laboratories, American Gas Association. Canadian Standards Association or Canadian Gas Association (as applicable). The use of other than factory supplied replacement parts will void the warranty.

KETTLE AND SKILLET FAUCET

Item No.	Part No.	Description	Qty.
1	SE50020	Hot Water Stem Assy.	1
2	SE50021	Cold Water Stem Assy.	1
3	SE50022	Yoke Connection Kit	1
4	FA00016	"0" Ring	1
5	FA95022	Retaining Ring	1
6	KE51404	Spout Nut	1
7	see chart	3/4" spout (please see 3/4" spout chart below)	1
8	N/A	3/4" spout with-Aerator (please order Item No. 4,5,6,7)	1
9	KE51401	Single Pantry Control Valve (incl. Item No. 2)	1
10	KE51403	Double Pantry Control Valve (incl. Item No. 1,2,3)	1
11	N/A	Old Style Single Pantry Control Valve (please order Item No 4.5.6.7,9)	1
	N/A	Old Style Double Pantry Control Valve (please order Item No. 4.5.6.7.10)	1
12	N/A	1" Spout (please order Item No. 4,5.6.7.14)	1
13	FA00115	"0" Ring	2
14	SE50061	Adapter (to adapt new style spout to old style control valve)	1

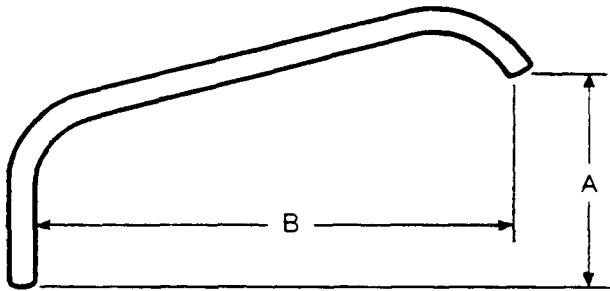

A	B	Part No.
4"	8"	KE50833
10"	9"	KE50832
6"	22"	KE50831
12 1/2"	14"	KE50830
10 3/4"	14"	KE50829
5"	14"	KE50828
24"	9"	KE50827
20"	9"	KE50826
12 1/2"	9"	KE50825

Use only replacement parts which are factory supplied as to preserve the certification of Underwriters Laboratories, American Gas Association. Canadian Standards Association or Canadian Gas Association (as applicable). The use of other than factory supplied replacement parts will void the warranty.

KETTLE AND SKILLET FAUCET

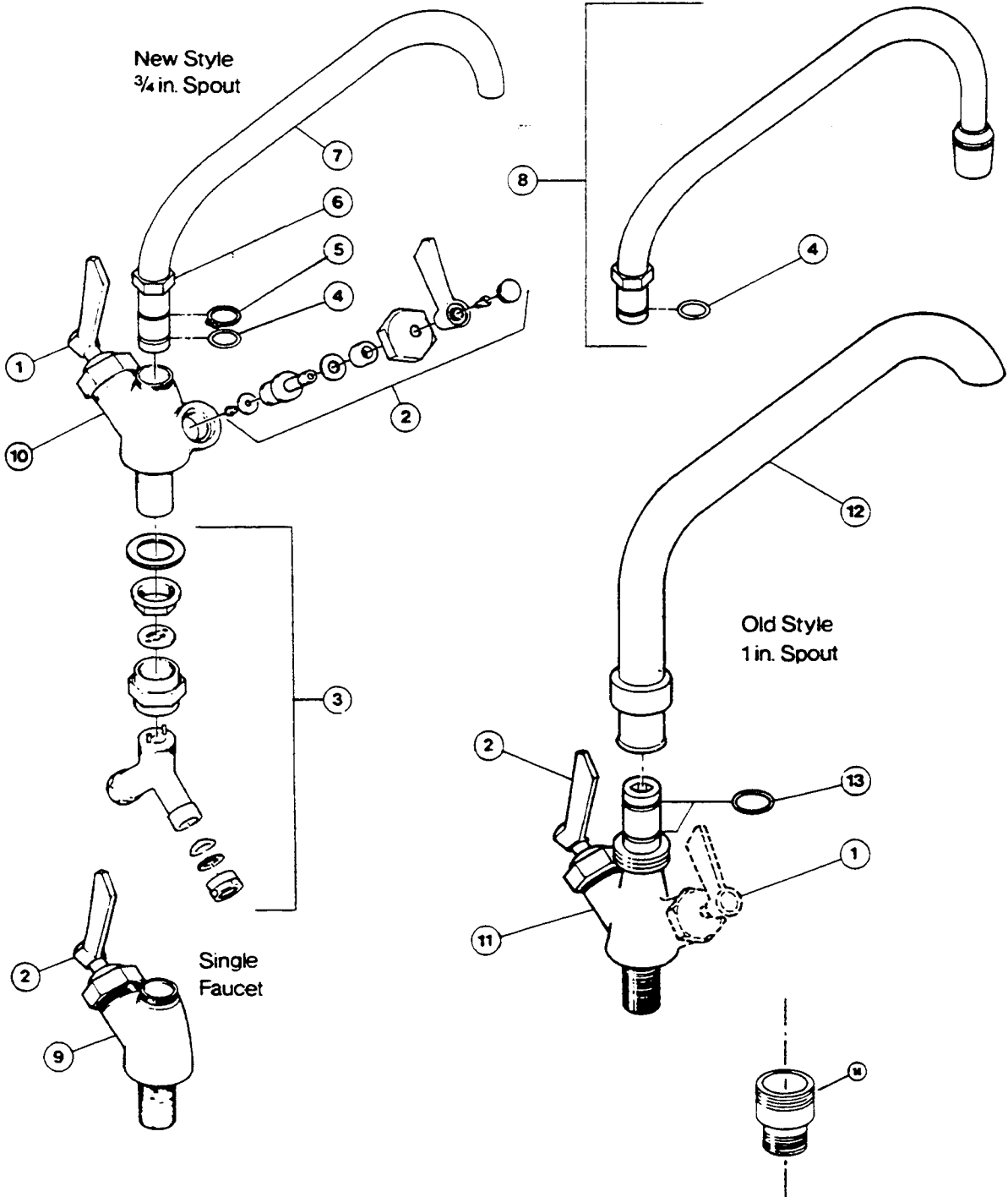

ALL ELECTRIC KETTLES SERVICING GUIDE

This section contains servicing information intended for use by Authorized Service Personnel.

Note 1: If Fault Isolation Procedure is required, be sure to start at step #1,

Note 2: On table top kettles the entire control mounting panel may be removed from kettle control housing for easier troubleshooting and parts replacement.

A/ Problem: Kettle is not heating at all. (Kettle must be on and temperature control set.)

Possible Causes

- | | |
|---------------------------------|---------------------------------------|
| 1. No incoming power. | 8. Defective potentiometer. |
| 2. Kettle is tilted. | 9. Defective low water level probe. |
| 3. Low water condition. | 10. Defective thermistor |
| 4. Defective on/off switch | 11. Defective 240/16 VAC transformer. |
| 5. Defective 12 VDC relay. | 12. Defective control box. |
| 6. Defective safety thermostat. | 13. Defective elements. |
| 7. Defective contactor/s. | |

Fault Isolation Procedure

Result Remedy

Step Test

1. Is there proper incoming voltage at terminal block"?	Yes	Go to step #2.
	No	Correct external power supply problem.
2. Is the red LED illuminated?	Yes	Follow Kettle Filling Procedure. If this does not correct the problem, go to PROBLEM D
	No	Go to step #3.
3. Is the green LED illuminated?	Yes	Go to step #4.
	No	Go to step #7.
4. Do both contactors energize?	Yes	Check contactor contacts for pitting Voltage across contactor terminals while in a closed position indicates a poor contact. Replace contactor/s as necessary. Check elements for short to ground or an open circuit. If element/s are defective contact the factory. Elements are not field replacable.
	No	Go to step #5.
5. Measure continuity across safety thermostat. Is it an open circuit?	Yes	Replace defective safety thermostat.
	No	Go to step #6.
6. Is there 120 VAC present across the coils of the contactors?	Yes	Replace defective contactor/s.
	No	Replace defective 12 VDC relay.

7. Remove wire from low water level probe and ground it to the body of the kettle. Do the contactors now energize?	Yes	Clean or replace defective low water level probe. Replace defective red LED.
	No	Go to step #8.
8. Is there 16 VAC present at output of 16 VAC transformer?	Yes	Go to step #9.
	No	Replace defective 240/16 VAC transformer.
9. Measure continuity of ON/OFF switch. Is it operating properly?	Yes	Go to step #10.
	No	Replace defective ON/OFF switch.
10. Unplug control box and measure the resistance across potentiometer. Is it approx. 0 ohms at max. and 50,000 ohms at min. settings?	Yes	Go to step #11.
	No	Replace defective potentiometer.
11. Remove edge connector from control box. While kettle is cold or thermistor is removed and allowed to cool, measure the resistance between edge connectors pins #2 and #7. Is it approx. 100,000 ohms?	Yes	Spray contact cleaner on control box terminals and edge connector. Try box again, if problem still exists, replace defective control box.
	No	Replace defective thermistor.

B/ Problem: Kettle heats too slowly or not hot enough.

(Note: normal max. operating pressure with an empty kettle is 30-35 psi.)

Possible Causes

- | | |
|---|---------------------------|
| 1. Air in kettle jacket - requires venting. | 5. Defective contactors. |
| 2. Defective safety thermostat. | 6. Defective control box. |
| 3. Defective potentiometer. | 7. Defective element/s. |
| 4. Defective thermistor. | |

Fault Isolation Procedure

	Result	Remedy
Step Test	Yes	Go to step #2.
1. In a cold state, does the pressure gauge read in the green zone?	No	There is air present in the jacket of the kettle. Follow Kettle Venting Procedure. If constant venting is required, there is a leak that should be corrected.
2. Do the contactors shut off too early? (before reaching normal max. operating pressure)	Yes	Go to step #3.
	No	Check contactor contacts for pitting. Voltage across terminals of contactor while energized signifies a poor contact. Replace contactor/s as necessary. Check elements for short to ground or open circuit. If elements are defective, contact the factory Elements are not field replaceable.
3. Does the green LED remain illuminated after the contactors shut off?	Yes	Replace defective safety thermostat.
	No	Go to step #4.

4. Unplug control box and measure the resistance across potentiometer. Is it approx. 0 ohms at max. and 50.000 ohms at min. settings?	Yes	Go to step #5.
	No	Replace defective potentiometer.
5. Remove kettle thermistor and allow to cool. Remove edge connector from control box. Test resistance across edge connectors pins #2. and #7. Is it approx. 100.000 ohms?	Yes	Go to step #6.
	No	Replace defective thermistor.
6 Turn the potentiometer on the control box clockwise to increase the max. operating temperature. Does the kettle now achieve max. operating pressure of 30-35 psi in an empty kettle?	Yes	Kettle is operating properly.
	No	Spray contact cleaner on control box terminals and edge connector; Try box again. If problem still exists, replace defective control box.

C/ Problem: Kettle is overheating.

Possible Causes

- 1 Defective thermistor.
- 2 Defective potentiometer.
3. Defective 12 VDC relay.
4. Defective control box.

Fault Isolation Procedure

Step Test	Result	Remedy
1. Does the green LED turn off even though the contactors remain energized?	Yes	Replace defective 12 VDC relay.
	No	Go to step #2.
2. Unplug the control box and measure the resistance across the potentiometer. Is the resistance approx. 0 ohms at max. and 50.000 ohms at mm. settings?	Yes	Go to step #3.
	No	Replace defective potentiometer.
3. Remove kettle thermistor and allow to cool. Remove edge connector from control box. Test resistance across edge connectors pins #2 and #7. Is it approx. 100,000 ohms?	Yes	Go to step #4.
	No	Replace defective thermistor.
4. Turn the potentiometer on the control box counter-clockwise to decrease the max. operating temperature. Does the kettle continue to overheat?	Yes	Spray contact cleaner on control box terminals and edge connector Try box again. If problem still exists, replace defective control box.
	No	Kettle is operating properly.

HINGE ADJUSTMENT INSTRUCTIONS

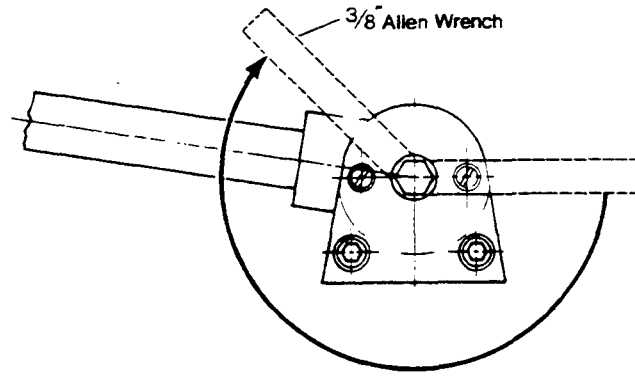

1. Insert 3/8" Allen wrench.
2. Turn clockwise to relieve tension on spring.
3. While tension is released remove one of the two slotted screws.
4. To prevent Allen wrench from springing back abruptly while the second slotted screw is removed, insert a pin (approximately 1/8") in the hole where the first slotted screw was removed from.
5. Remove second slotted screw.
6. While holding Allen wrench remove pin.
7. Turn Allen wrench clockwise to tighten or counter-clockwise to loosen tension to produce desired effect.
8. Re-insert pin in one of the two holes.
9. Tighten one slotted screw in the other hole (it may be necessary to turn Allen wrench slightly to align holes.)
10. Remove pin and repeat step number 9 for other slotted screw.

ELECTRIC KETTLE WIRING DIAGRAM

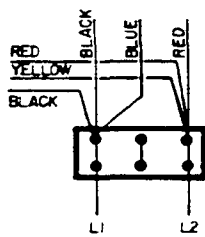
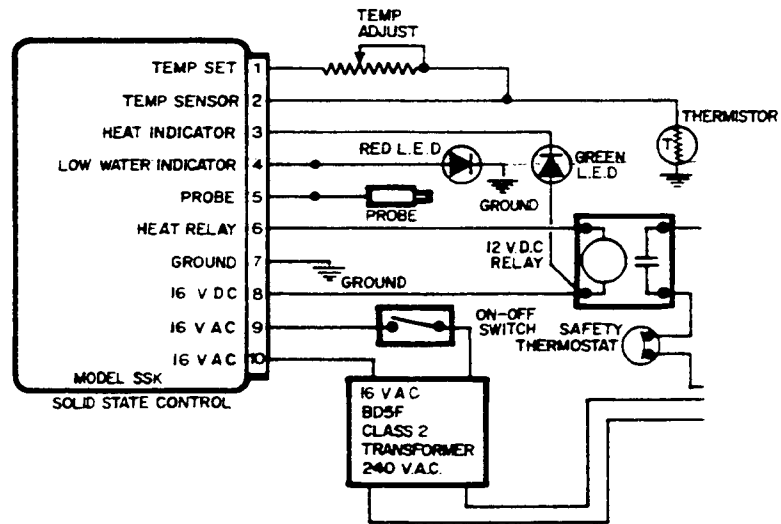

**Single
Phase**

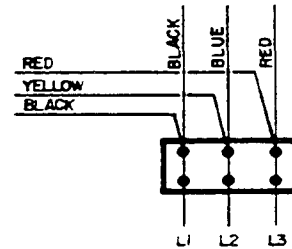

**Three
Phase**

PEDESTAL ELECTRIC STEAM KETTLES

MAINTENANCE

Draw-off Valve Maintenance:

To correct a leak at the draw-off valve, the source of the leak must first be determined. Leaks from around the valve stem are corrected by simply replacing the "O" ring. Faulty seating of the valve stem disc against the valve body seat may cause dripping from the valve even when the valve is tightly closed. This can often be corrected by cleaning any residue from the disc and seat with a piece of very fine emery cloth.

KETTLE VENTING INSTRUCTIONS

If the vacuum/pressure gauge reading is in the "vent air" zone, it means that air has entered the steam/water jacket, resulting in little or no vacuum. This reduces kettle efficiency by slowing its heating process, as the water cannot boil when air is present in the jacket. To remedy this situation, the following venting procedures should be followed:

1. With the temperature control knob set at number 6, heat the empty kettle until the vacuum / pressure gauge indicates 5-10 psi.
2. Release steam and air from the steam/water jacket by loosening, one-half turn, the 7/16" chrome-plated brass venting valve nut (located at the rear of the kettle) for 3-6 seconds.
3. Tighten the vent valve nut, being careful not to overtighten.

The kettle's steam/water jacket should now be free of air. At room temperature, the pressure gauge needle should rest in the green zone, indicating a vacuum in the kettle's jacket. To check the gauge for proper vacuum after venting, the temperature can be quickly reduced by filling the kettle with cold water.

If the kettle will not hold a vacuum, test for leaks at the vent valve, the safety valve, the probe, and the vacuum/pressure gauge fittings. We suggest mixing a 50/50 solution of liquid detergent and water while heating the kettle to at least 5 psi pressure. Then, shut off power to the kettle at the fused disconnect switch. The soapy solution should be applied to the suspected area while the gauge shows at least 5 psi pressure. Any bubbles which appear will indicate a leak.

WARNING: The fused disconnect switch must be switched off before removing the kettle's bottom cover, which exposes dangerous high voltage.

RESERVOIR FILL PROCEDURES

The reservoir's water level must be maintained at the proper level to submerge the heater elements. Under normal operating conditions, the sealed water reservoir should never require the addition of water. If the red "low water" light comes on during use (while the kettle is in an upright position), the water level has reached a critically low level. The low water protection control has automatically shut off the heater elements. The following procedure must be completed before further use:

NOTE: Ensure that the red "low water" light is on when the kettle is **upright**. On tilting kettles, it is normal for the red light to come on when the kettle is in a tilted position, as the elements are not submerged in water at this point.

- 1 Shut off power to the kettle at the fused disconnect switch.
- 2 Remove the bottom cover. (Tilting kettles can be tilted forward for easier access to the cover. Tilt the kettle back to the upright position once the cover has been removed).
- 3 Unscrew and remove the chrome-plated brass venting valve nut located on the back of the kettle.
- 4 Hold the safety valve open while adding distilled water through the vent hole, using a funnel.
- 5 Place the chrome-plated brass venting valve nut into the water fill hole and carefully tighten. Do not over-tighten. Replace the bottom cover.
- 6 Restore power to the kettle at the fused disconnect switch.
- 7 The kettle must now be vented. Refer to the "Kettle Venting Instructions".

Kettle Capacity	When Red "Low Water Light" Comes On, Add Distilled Water	When the Water Reservoir is Completely Empty, Add Formula*
2 gal	50 oz.	120oz.
5 gal	70 oz	160oz
10 gal	120oz	2 gal
20 gal.	1.0 gal.	3 gal.
30 gal	1.8 gal	4 1/4 gal
40 gal	2.0 gal	4 1/2 gal.
60 gal.	2.1 gal	5 1/2 gal.
80 gal	2.6 gal.	6 1/4 gal.
100 gal	2.8 gal	7 gal.

*Anti-freeze and rust Inhibitor formula:

CAUTION: Only distilled water should be used when adding water to a partially filled water reservoir. Local tap water conditions may cause kettle damage which is not covered under warranty.

Rust Inhibitor:	3 oz.	=	0.6%
Anti-Freeze:	64 oz.	(.5 gal.)	= 12.4%
Tap Water:	448 oz.	(3.5 gal.)	= 87.0%