



Visit www.clevelandrange.com to locate a service or sales representative in your area.

Cleveland

Electric Mixer Kettles – Potentiometer Controller

Operation, Installation & Maintenance Manual

This manual is updated as new information and models are released. Visit our website for the latest manual.

MODELS:

- MKEL-40-T
- MKEL-60-T
- MKEL-80-T
- MKEL-100T
- TMKEL-40-T
- TMKEL-60-T
- TMKEL-80-T
- TMKEL 100-T

For your future reference.

Model # _____

Serial # _____



Read the manual thoroughly. Improper installation, operation or maintenance can cause property damage, injury, or death.

Part # KE004011-2 Rev C
October 2025

TABLE OF CONTENTS

STATEMENT OF RESPONSIBILITIES	3
FOR YOUR SAFETY	5
NOTICE.....	8
FOR THE USER	8
INSTALLATION	9
GENERAL.....	9
RECEIVING INSPECTION	9
SHIPPING DAMAGE INSTRUCTIONS.....	9
UNCRATING.....	9
VENTILATION	9
POSITIONING	10
ELECTRICAL.....	11
CLEANING.....	11
INSTALLATION CHECKS.....	11
MIXER.....	11
OPERATING INSTRUCTIONS	12
OPERATING CONTROLS AND INDICATORS	12
OPERATING THE KETTLE	13
CLEANING INSTRUCTIONS.....	17
PREVENTATIVE MAINTENANCE	18
DAILY PRE-STARTUP INSPECTION.....	18
SIX MONTH SERVICE INSPECTION	18
YEARLY SERVICE INSPECTION	18
TROUBLESHOOTING AND MAINTENANCE PROCEDURES.....	19
DIAGNOSTIC GUIDE	19
SAFETY INSPECTION CHECKLIST	21
THERMISTOR REPLACEMENT	25
REPAIRING LEAKS IN STEAM	25
JACKETED KETTLE FITTINGS	25
KETTLE JACKET CLEANOUT AND PASSIVATION PROCEDURES	26
LUBRICATION PROCEDURE	Error! Bookmark not defined.
RESERVOIR FILL PROCEDURES	28
DRAINING PROCEDURE.....	28
HYDRAULIC OIL REPLACEMENT PROCEDURE.....	29
RE-INSTALLING SPEED CONTROL CABLE	29
AIR LINE LUBRICATOR OIL FILLING PROCEDURE	29

STATEMENT OF RESPONSIBILITIES / DÉCLARATION DE RESPONSABILITÉS / DECLARACIÓN DE RESPONSABILIDADES

This document is for use by experienced and trained Qualified Cleveland Range, LTD Authorized Service Representatives who are familiar with both the safety procedures, and equipment they service. Cleveland Range, LTD assumes no liability for any death, injury, equipment damage, or property damage resulting from use of, improper use of, or failure to use the information contained in this document. Cleveland Range, LTD has made every effort to provide accurate information in this document, but cannot guarantee that this document does not contain unintentional errors and omissions.

The information in this document may be subject to technical and technological changes, revisions, or updates. Cleveland Range, LTD assumes no liability or responsibility regarding errata, changes, revisions, or updates.

Qualified Cleveland Range, LTD Authorized Service Representatives are obligated to follow industry standard safety procedures, including, but not limited to, OSHA regulations, and disconnect / lock out / tag out procedures for all utilities including steam, and disconnect / lock out / tag out procedures for gas, electric, and steam powered equipment and / or appliances.

All utilities (gas, electric, water and steam) should be turned OFF to the equipment and locked out of operation according to OSHA approved practices during any servicing of Cleveland Range equipment

Qualified Cleveland Range, LTD Authorized Service Representatives are obligated to maintain up-to-date knowledge, skills, materials and equipment.

Ce document est destiné à l'usage des Représentants de Service qualifiés et autorisés de Cleveland Range, LTD qui possèdent l'expérience et la formation ainsi que la bonne connaissance des mesures de sécurité et du matériel qu'ils entretiennent.

Cleveland Range, LTD décline toute responsabilité pour tout cas de décès, blessure, dommage matériel ou dommage aux biens résultant de l'utilisation, de la mauvaise utilisation ou du manquement d'utilisation des renseignements contenus dans ce document.

Cleveland Range, LTD s'est efforcé à fournir des renseignements précis dans ce document mais ne peut garantir que ce document soit exempt d'erreurs et d'omissions non intentionnelles.

Les renseignements contenus dans ce document peuvent être assujettis à des changements techniques et technologiques, des révisions ou des mises à jour.

Cleveland Range, LTD décline toute obligation ou responsabilité concernant les errata, modifications, révisions ou mises à jour.

Les Représentants de Service qualifiés et autorisés de Cleveland Range, LTD sont tenus de se conformer aux mesures de sécurité normalisées de l'industrie, y compris, mais sans s'y limiter, les réglementations de l'OSHA, les procédures de débranchement / verrouillage / étiquetage relatives à tous les services publics, dont l'approvisionnement en vapeur, et les procédures de débranchement / verrouillage / étiquetage relatives aux équipements et/ou appareils fonctionnant au gaz, à l'électricité et à la vapeur.

Au cours de tout entretien d'un appareil Cleveland Range, tous les services publics (gaz, électricité, eau et vapeur) doivent être FERMÉS au niveau de l'appareil et le dispositif de fonctionnement doit être verrouillé suivant les pratiques approuvées de l'OSHA.

Les Représentants de Service qualifiés et autorisés de Cleveland Range, LTD sont tenus d'actualiser en permanence leurs connaissances, compétences, matériel et équipement.

Este documento está destinado para el uso de los Representantes de Servicio calificados y autorizados de Cleveland Range, LTD quienes cuentan con la experiencia y la capacitación así como el buen conocimiento de las medidas de seguridad y de los equipos que mantienen.

Cleveland Range, LTD, declina toda responsabilidad en caso de cualquier fallecimiento, lesiones, daños al equipo o daños a la propiedad resultantes de la utilización, del uso indebido o de la falta de utilización de la información provista en este documento.

Cleveland Range, LTD se ha esforzado en suministrar información precisa en este documento, pero no puede garantizar que este documento esté exento de errores y de omisiones no intencionales.

La información contenida en este documento podría estar sujeta a cambios técnicos o tecnológicos, revisiones o actualizaciones. Cleveland Range, LTD declina toda obligación o responsabilidad con respecto a erratas, modificaciones, revisiones o actualizaciones.

Los Representantes de Servicio calificados y autorizados de Cleveland Range, LTD tienen la obligación de seguir los procedimientos estándar de seguridad de la industria; los cuales incluyen pero no se limitan a los reglamentos de la OSHA (La Administración de la Seguridad y Salud Ocupacionales), los procedimientos de desconexión, cierre y etiquetado relativos a todos los servicios públicos incluyendo el suministro de vapor y los procedimientos de desconexión, cierre y etiquetado para los equipos y/o aparatos que funcionan a base de gas, electricidad o vapor.

Cuando se esté dando servicio o mantenimiento a un aparato de Cleveland Range, todos los servicios públicos (gas, electricidad, agua y vapor) deben estar APAGADOS para el equipo en cuestión y se debe seguir el procedimiento de cierre de operaciones de acuerdo con las prácticas aprobadas por la OSHA.

Los Representantes de Servicio calificados y autorizados de Cleveland Range, LTD tienen la obligación de actualizar constantemente sus conocimientos, destrezas, materiales y equipamiento.

WARRANTY DISCLAIMER

Our Kettles, Mixers, Skillets, and Steamers are designed for commercial kitchen environments. To ensure optimal performance, longevity, and safety, the following conditions must be maintained:

- **Humidity & Moisture:** The equipment is designed to operate within standard commercial kitchen humidity levels of **40% to 65%** relative humidity. Prolonged exposure to humidity levels exceeding **65%** may compromise electrical components, cause condensation-related issues, and reduce equipment lifespan. Proper ventilation is essential to maintaining safe conditions.
- **Steam, Condensate & Water Exposure:** While the equipment can withstand occasional water splashes and steam exposure, direct and prolonged contact with high-pressure steam or continuous water spray may cause damage and void the warranty. Effective ventilation is required to manage steam buildup.
- **Ambient Temperature:** The recommended operating temperature range is **13°C (55°F) to 39°C (102°F)**. Exposure to temperatures beyond this range may impact performance, lead to malfunctions, or pose safety risks.
- **Ventilation Requirements:** Proper ventilation must be maintained to prevent excessive heat and humidity buildup, which can lead to overheating, reduced efficiency, and premature wear. Gas-fired equipment must only be installed under a ventilation hood in a room with adequate makeup air. Always consult local regulations to ensure compliance with ventilation standards.
- **Water Quality:** Follow Cleveland Range's water quality guidelines to ensure optimal equipment performance. Softening hard water reduces deposits, and filtration removes corrosive elements. Regular descaling, as recommended, prevents scale buildup. Consult a water treatment specialist and follow local regulations for proper management.
- **Installation and Preventive Maintenance:** Follow Cleveland Range's installation and preventive maintenance guidelines to ensure proper functioning and longevity of the units. Regular upkeep prevents issues and ensures optimal performance. Failure to follow the schedule may lead to reduced efficiency and breakdowns.
- **Drainage System:** Failure to follow Cleveland Range specifications may result in damage. Do not place a drain beneath the unit, as excessive moisture can shorten the lifespan of electrical and gas components, leading to potential malfunctions or hazards.

Failure to adhere to these conditions may result in decreased efficiency, equipment damage, or safety hazards and may void the manufacturer's warranty.

**FOR YOUR SAFETY / POUR VOTRE SÉCURITÉ /
PARA SU SEGURIDAD**

FOR YOUR SAFETY

Do not store or use gasoline or any other flammable liquids and vapours in the vicinity of this or any other appliance.

WARNING: Improper installation, operation, adjustment, alteration, service or maintenance can cause property damage, injury or death. Read the installation and operating instructions thoroughly before installing, operating or servicing this equipment.

Do not spray aerosols in the vicinity of this appliance while it is in operation.

This appliance is not to be used by persons with reduced physical, sensory or mental capabilities, or lack of experience and knowledge, unless they have been given supervision or instruction concerning use of the appliance by a person responsible for their safety.

This appliance is not for use by children and they must be supervised not to play with it.

Retain this manual for your reference.

POUR VOTRE SÉCURITÉ

Ne pas entreposer ou utiliser d'essence ou d'autres liquides ou vapeurs inflammables à proximité de cet appareil ou de tout autre appareil.

AVERTISSEMENT: Toute mauvaise pratique en matière d'installation, de fonctionnement, de réglage, de modification, d'entretien ou de maintenance peut causer des dommages matériels, des blessures ou la mort. Lisez la totalité des instructions d'installation et d'utilisation avant d'installer, d'utiliser ou d'entretenir cet équipement.

Ne pas pulvériser des aérosols dans le voisinage de cet appareil alors qu'il est en fonctionnement.

Cet appareil ne doit pas être utilisé par des personnes dont les capacités physiques, sensorielles ou mentales sont réduites, ou des personnes dénuées d'expérience ou de connaissance, sauf si elles ont pu bénéficier, par l'intermédiaire d'une personne responsable de leur sécurité, d'une surveillance ou d'instructions préalables concernant l'utilisation de l'appareil.

Conservez ce manuel pour votre référence.

PARA SU SEGURIDAD

No guarde ni use gasolina o cualesquiera otros líquidos o vapores inflamables en las cercanías de éste o cualquier otro aparato.

















ADVERTENCIA: La indebida instalación, operación, ajuste, modificación, servicio o mantenimiento puede ocasionar daños a la propiedad, lesiones o muerte. Lea detenidamente las instrucciones de instalación y de operación antes de instalar, poner a funcionar o dar servicio a este equipo.





No pulverice aerosoles en las proximidades de este aparato mientras está en funcionamiento.

Este aparato no debe ser utilizado por personas con capacidades físicas, sensoriales o mentales reducidas, o que no tengan la experiencia y los conocimientos adecuados, a menos que estas personas hayan recibido supervisión e instrucciones en cuanto al uso del aparato por la persona responsable de la seguridad de ellas.

Guarde este manual para su referencia.

WARNING / AVERTISSEMENT / ADVERTENCIA

	<p>Inspect unit daily for proper operation. / Inspecter le bloc quotidiennement pour garantir le fonctionnement normal. / Inspeccione diariamente el funcionamiento correcto de la unidad.</p>		<p>Stand clear of product discharge path when discharging hot product. / Se tenir loin du chemin de purge des produits lors de la purge des produits chauds. / Manténgase alejado de la trayectoria de descarga del producto al descargar producto caliente.</p>
	<p>Heavy. / Lourd. / Pesado Team or mechanical lift. / Levage en équipe ou mécanique. / Levantamiento en equipo o mecánico.</p>		<p>Surfaces may be extremely hot! Use protective equipment. / Les surfaces peuvent être extrêmement chaudes ! Utiliser des équipements de protection. / ¡Las superficies pueden estar muy calientes! Utilice equipo protector.</p>
	<p>Keep clear of pressure discharge. / Se tenir hors de portée de la purge des soupapes de surpression. / Manténgase alejado de la descarga de presión.</p>		<p>Keep hands away from moving parts and pinch points. / Tenir les mains à l'abri des pièces mobiles et des angles. / Mantenga las manos lejos de las piezas móviles y los puntos de presión.</p>
	<p>Hot product and surfaces. / Produit et surfaces chaudes. / Producto y superficies calientes. Do not touch. / Ne pas toucher. / No la toque.</p>		<p>Do not fill kettle above recommended level marked on outside of kettle. / Ne pas remplir le chaudron au-delà du niveau indiqué à l'extérieur. / No llene la marmita por encima del nivel recomendado marcado en la parte exterior de la marmita.</p>
	<p>Unit must be anchored as per manual. / Unité doit être ancrée selon les directives du manuel.</p>		<p>Opening the drain cock will lead to the outflow of the hot contents of the boiling pan. Wear protective equipment when discharging hot product. / L'ouverture du robinet de vidange entraînera l'écoulement du contenu chaud de la marmite. Porter des équipements de protection lors de la purge des produits chauds. / La apertura de la llave de drenaje provocará la salida del contenido caliente de la marmita. Utilice equipo protector al descargar producto caliente.</p>
	<p>Floor may become slippery from product spillage. / Déversement de produit peut causer de plancher à être glissant. / Derrame de producto puede causar piso a ser resbaladizo.</p>		<p>In case of emergency or breakdown, refer to "Emergency" in OPERATING THE KETTLE section. / En cas d'urgence ou de panne, reportez-vous à « Urgence » dans la section FONCTIONNEMENT DE LA BOUILLIÈRE. / En caso de emergencia o avería, consulte "Emergencia" en la sección FUNCIONAMIENTO DEL HERVIDOR.</p>
	<p>Do not lean on or place objects on kettle lip. / Ne pas adosser ou placer des objets contre le bord de chaudron. / No se apoye en la tapa de la marmita ni coloque objetos sobre ella.</p>		<p>Do not remove guards or operate without them. / Ne pas supprimer les gardes ou fonctionner sans eux. / No retire los guardias ni funcionar sin ellos.</p>
	<p>Do not climb, sit or stand on equipment. / Il ne faut pas monter, s'asseoir ni se tenir debout sur l'équipement. / No subirse, ni sentarse ni pararse sobre el equipo.</p>		<p>Have a qualified service technician maintain your equipment. / Demandez à un technicien en entretien et en réparation qualifié d'effectuer l'entretien de votre équipement. / Haga que un técnico de servicio calificado mantenga su equipo.</p>

	<p>Keep appliance and area free and clear of combustibles. / Gardez l'appareil et son entourage libre de tous combustibles. / Mantenga el aparato y el área libres de combustibles.</p>		<p>Do not attempt to operate this appliance during a power failure. / N'essayez pas de faire fonctionner cet appareil lors d'une panne de courant. / No intente poner en marcha este aparato durante un fallo de suministro eléctrico.</p>
	<p>Shut off power at main fuse disconnect prior to servicing. / Couper l'alimentation sur le principal fusible sectionneur avant l'entretien. / Apague la alimentación eléctrica en el fusible desconector principal antes de darle servicio.</p>		<p>Ensure kettle is at room temperature and pressure gauge is showing zero or less prior to removing any fittings. / S'assurer que le chaudron se trouve dans une température ambiante et que le manomètre affiche zéro ou moins avant de déposer les raccords. / Asegúrese de que la marmita está a temperatura ambiente y el manómetro está mostrando cero o menos antes de quitar cualquier accesorio.</p>
POWER SUPPLY / SOURCE DE COURANT / FUENTE DE ALIMENTACIÓN			
	<p>Appliance must <u>not</u> be supplied through an external switching device that is regularly switched on and off. / L'appareil ne doit pas être alimenté par un interrupteur externe régulièrement allumé et éteint. / El aparato no debe ser alimentado a través de un dispositivo de conmutación externo que se encienda y apague periódicamente.</p>		
MAINTENANCE / ENTRETIEN / MANTENIMIENTO			
	<p>The pressure relief valve must be inspected every six months. / La soupape de décharge doit être inspectée à tous les six mois. / La válvula de descarga de presión debe ser inspeccionada cada seis meses.</p> <p>Have a qualified service technician inspect your unit yearly. / L'unité doit être inspectée annuellement par un technicien de service qualifié.</p>		
	<p>Greasing must be performed every six months, as outlined in the maintenance procedures, to prevent wear or damage. / La lubrification doit être effectuée tous les six mois, conformément aux procédures de maintenance, afin d'éviter l'usure ou les dommages.. / La lubricación debe realizarse cada seis meses, según los procedimientos de mantenimiento, para evitar el desgaste o los daños.</p>		

NOTICE

FOR THE USER

Read the Operating instructions thoroughly before using this equipment.

FOR THE INSTALLER

Read the Installation instructions thoroughly before installing or servicing this equipment.

Improper installation, adjustment, alteration, service or maintenance can cause property damage, injury or death.

This appliance is not to be used by persons with reduced physical, sensory or mental capabilities, or lack of experience and knowledge, unless they have been given supervision or instruction concerning use of the appliance by a person responsible for their safety.

This appliance is not for use by children, and they must be supervised not to play with it.

Any repairs to the pressure vessel must be done by a certified pressure vessel repair shop and all repair methods and materials must be approved by the manufacturer.

MODEL NUMBER LEGEND:

1	2	3	-	4	-	5
---	---	---	---	---	---	---

1 – Type of Equipment

MK = Mixer Kettle

TMK = Twin Mixer Kettle

2 – Type of Power

E = Electricity

G = Gas

D = Direct Steam

3 – Type of Mount

L = Legs or Frame

M = Modular (Cabinetized)

T = Table Top

4 – Designation of Capacity in Gallon

From 3 Gallon to 200 Gallon

5 – Tilting Options

Blank = Stationary

T = Tilting

PRODUCT RANGE:

The range of mixer kettles, along with their Pressure and Volume, in this manual is specified in the table below:

Style	Model Number	Canadian Registration Number	Pressure PSI (kPA)	Volume (Litres)	PV	Category
EK	MKEL-40-T, TMKEL-40-T	L6537.5	50 (345)	50	172.5	2
	MKEL-60-T, TMKEL-60-T	L6538.5	50 (345)	68	234.6	3
	MKEL-80-T, TMKEL-80-T	L6539.5	50 (345)	87	300.2	3
	MKEL-100-T, TMKEL-100-T	L6541.5	50 (345)	105	362.3	3

INSTALLATION

GENERAL

Operating Criteria	Acceptable Range
Ambient Air Temperature	15°C to 40°C / 59° F to 104° F
Relative Humidity	0-80%
Altitude	0 to 3000 meter / 0 to 9850 ft.
Voltage	See 'Electrical Connection'
Location	Inside building, under ventilation hood
Water Inlet Operating Pressure Range	275 Kpa to 1Mpa

Ensure electrical supplies match rating plate.

Installation of the kettle must be accomplished by qualified electrical installation personnel working to all applicable local and national codes. Improper installation of product could cause injury or damage.

This equipment is built to comply with applicable standards for manufacturers. Included among those approval agencies are UL, NSF, ASME/N.Bd., CSA, ETL, and others. Many local codes exist, and it is the responsibility of the owner/installer to comply with these codes.

Observe all clearance requirements. Do not obstruct the flow of combustion and ventilation air.

RECEIVING INSPECTION

Before unpacking visually inspect the unit for evidence of damage during shipping.

If damage is noticed, do not unpack the unit, follow Shipping Damage Instructions shown below.

SHIPPING DAMAGE INSTRUCTIONS

If shipping damage to the unit is discovered or suspected, observe the following guidelines in preparing a shipping damage claim.

1. Write down a description of the damage or the reason for suspecting damage as soon as it is discovered. This will help in filling out the claim forms later.
2. As soon as damage is discovered or suspected, notify the carrier that delivered the shipment.
3. Arrange for the carrier's representative to examine the damage.
4. Fill out all carrier claims forms and have the examining carrier sign and date each form.

APPROXIMATE WEIGHT

Model #	Unit	Unit with shipping box
MKEL40T	820 lbs.	890 lbs.
MKEL60T	870 lbs.	940 lbs.
MKEL80T	1,130 lbs.	1,200 lbs.
MKEL100T	1,285 lbs.	1,355 lbs.

Model #	Unit	Unit with shipping box
TMKEL40T	1,600 lbs.	1,670 lbs.
TMKEL60T	1,670 lbs.	1,740 lbs.
TMKEL80T	1,840 lbs.	1,910 lbs.
TMKEL100T	2,150 lbs.	2,220 lbs.

UNCRATING

Caution:

Straps under tension and will snap when cut.

Carton may contain staples and skid contains nails.

Use proper safety equipment and precautions.



If unit is heavy, use adequate help or lifting equipment as needed.

1. Carefully cut any straps from container.
2. Lift off carton.
3. Inspect for hidden damage. If found, refer to "SHIPPING DAMAGE INSTRUCTIONS."
4. Cut strap holding unit.
5. Remove lag bolts from feet.
6. Remove manual from kettle pot. Write down the model# and serial# of the unit onto the front of this manual.
7. Lift kettle off skid and move kettle to its installation location.
8. Discard packaging material according to local and or national requirements.



VENTILATION

Operation of these units can produce significant levels of steam and condensate, it is recommended they be installed under a ventilation hood in a room which has provisions for adequate make up air. Further information can be obtained by referring to the U.S.A. National Fire Protection Associations NFPA96 regulations. These standards have also been adopted by the National Building Code in Canada.

POSITIONING

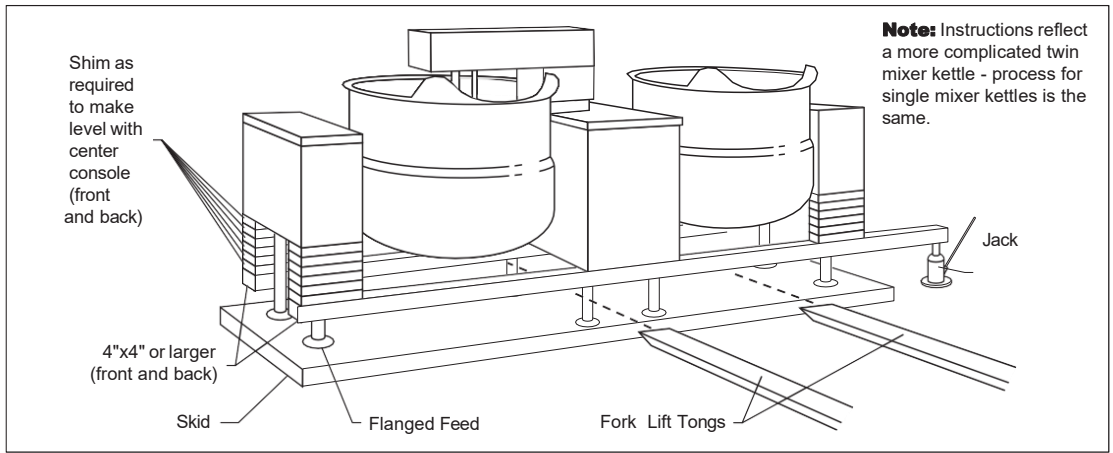

MOVING UNIT

1. While still on skid, move unit as close to final installation position as possible.
2. Prepare unit for lifting as shown in diagram.
3. Lift gently with a forklift or jacks and remove skid.
4. Lower gently to ground and remove forklift and blocking.
5. If unit has to be re-positioned, slide gently. Do not twist or push one side of unit excessively and cause binding on trunnions.

LEVELING

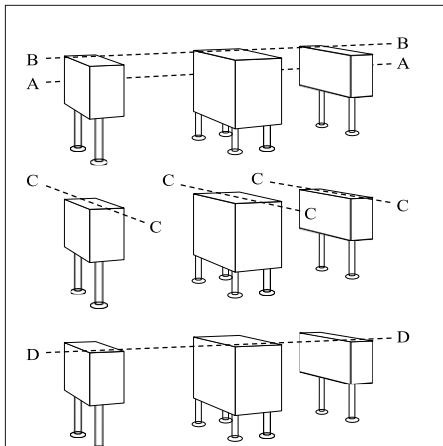

1. With straight-edge, line the backs of the consoles up with each other (dotted line **A**).
2. Level and straight-edge backs of consoles (dotted line **B**). Adjustments are made by turning flanges on back feet only.
3. Level consoles individually from front to back (dotted lines **C**). Adjustments are made by turning flanges on front feet only.
4. Re-check that the back is level (dotted line **B**) and then the front (dotted line **D**). Adjust if necessary.
5. Check that mixer bridge is level and guide pins (see illustration) lock smoothly without binding. If not repeat steps **1** through **4**.

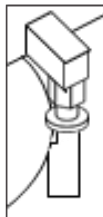

NOTE: See Operating Instructions before operating unit.

6. Make electrical connections (see electrical service connections) and test mixer bridge as follows:
 - A/** Raise mixer bridge: Move the bridge to its highest position.
 - B/** Swing bridge out over center console to far left and lower bridge.
 - C/** Bridge pins should enter pin hole on kettle perfectly. If not return to step 1 and repeat levelling steps

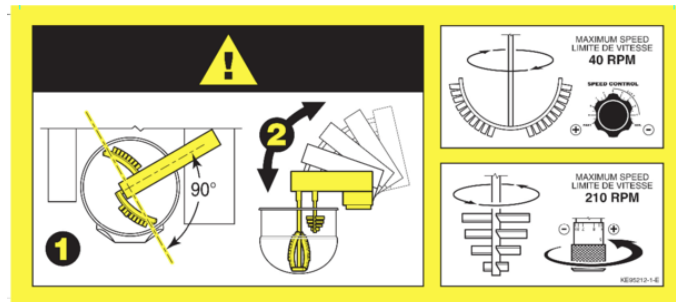

- D/** Raise bridge and swing to far right (for twin mixers only).
 - E/** Repeat steps **B** and **C** (for twin mixers only).
7. Once positioned and levelled, permanently secure the kettle's flanged feet to the floor using stainless steel lag bolts and floor anchors (supplied by the installer). Secure each of the flanged feet with one bolt in each hole. Seal joints of flanged feet with a silicone sealant.

ADDITIONAL TIPS:

- Verify that the hydraulic hoses are free from pinching and properly routed during movement of the arm.
- On twin mixer models, repeat all bridging and alignment checks for both sides.
- Ensure all electrical connections and safety systems are correctly installed before final operation.

ELECTRICAL

ELECTRICAL SERVICE CONNECTIONS

ENSURE THE ELECTRICAL SUPPLY MATCHES THE KETTLE'S REQUIREMENTS AS STATED ON THE RATING LABEL.

Install in accordance with local codes and/or the National Electric Code ANSI/NFPA No 70-1981 (USA) or the Canadian Electric Code CSA Standard C22.1 (Canada). A separate fused disconnect switch must be supplied and installed. The kettle must be electrically grounded by the installer. The electric supply must match the power requirements specified on the kettle's rating plate. The copper wiring must be adequate to carry the required current at the rated voltage. Refer to the specification sheet for electrical specifications.

NOTE: This appliance is not GFI (GFCI) compatible.

1. Ensure main power is turned off before connecting wires.
2. Remove the screws at the rear of the centre console cover and remove the cover. A wiring diagram is affixed to the underside of the console cover.
3. Feed permanent copper wiring 18" through the cut-out in the bottom of the console. Connect wiring in junction box in the bottom of the console.
4. Turn main power back on.
5. Check for correct rotation of electric motor (access by removing top front cover on centre console). Ensure motor rotation follows directional arrow on side of motor (anti-clockwise). If rotation is incorrect, disconnect main power and reverse any two of the three live lines.
6. Replace the console cover and secure it with screws.

WARNING: Do not wire to an external switching device that is regularly switched on and off.

CLEANING

After installation the kettle must be thoroughly cleaned and sanitized prior to cooking.

INSTALLATION CHECKS

Although the kettle has been thoroughly tested before leaving the factory, the installer is responsible for ensuring the proper operation of kettle once installed.

1. Before turning the kettle on, read the vacuum/pressure gauge. The gauge's needle should be in the green zone. If the needle is in the "VENT AIR" zone, follow air venting procedure.
2. Supply power to the kettle by placing the fused disconnect switch to the "ON" position.
3. Turn the temperature control knob to "1" (Min.). The green LED light should remain lit, indicating the burner is lit, until the set temperature is reached. Then the green light will cycle on and off, indicating the burner is cycling on and off to maintain temperature.
4. Tilt the kettle forward. After a few seconds the red "LOW WATER" light should be lit when the kettle is in a tilted position. This light indicates that the burner has automatically been shut off by the kettle's safety circuit. This is a normal condition when the kettle is in a tilted position.
5. Raise the kettle to the upright position. The red "LOW WATER" light should go out when the kettle is upright.
6. Turn the temperature control knob to "10" (Max.) and allow the kettle to preheat. The green light should remain on until the set temperature is reached. Then the green light will cycle ON and OFF, indicating the burner is cycling ON and OFF to maintain temperature.

MIXER

1. Raise Bridge - If bridge does not raise then check motor rotation. Bridge should not raise until speed control is turned to minimum and then adjusted back up.
2. Swing Bridge - Bridge when fully raised should swing without hitting any object, i.e. control housing, kettle lip. Check that hydraulic hoses are not being pinched by stops on swivel assembly.
3. Tilt Kettle - Kettle tilts smoothly both down and back up. If power tilt, check that micro switches are adjusted properly (kettle is level in upright position and drains fully when tilted) and are not being crushed by gear.
4. Lower Bridge - Raise bridge. Switch to mix. Turn speed control to zero to reset micro switch then set speed control to number four. Check that unit does not begin to mix until bridge has lowered part way into the kettle. Check that mixer bridge pin lowers into pin hole correctly
5. Speed Control - Main - Main agitator arm not rotating when set at "0" but will start to move slowly on "1". Speed control makes positive contact with micro switch.
6. Speed Control - Secondary - Set main speed control to five. Adjust secondary control from minimum to maximum. Look for considerable speed variance.
7. Water Faucets - Turn on hot water faucet. Turn off and check for leaks in piping and drips from faucet spout. Repeat above with cold water faucet.
8. Product Discharge - Add water to kettle. Check for leaks from valve. Open and close valve a few times and check for leaks again.

WARNING

If for any reason this unit is not functioning correctly DO NOT OPERATE. Contact your authorized service agent.

OPERATING INSTRUCTIONS



OPERATING CONTROLS AND INDICATORS

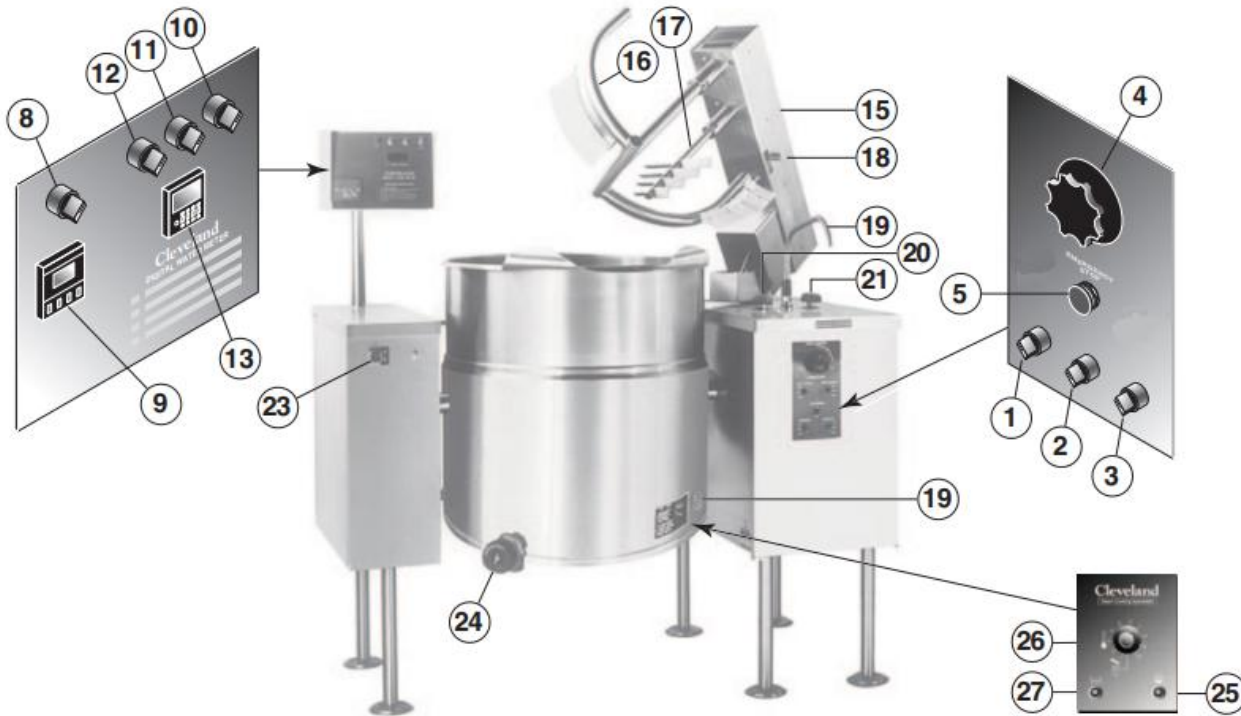

ITEM #	DESCRIPTION	FUNCTION
1.	MAIN POWER SWITCH	Power switch for unit.
2.	MIX/LIFT SWITCH	Sets hydraulics to mix or lift mode.
3.	UP/DOWN SWITCH	When unit is in lift mode, mixer bridge can be raised or lowered with this switch.
4.	MIXER SPEED CONTROL	Controls speed of agitators and mixer bridge lift.
5.	EMERGENCY STOP BUTTON	Stops hydraulic system (agitators and mixer bridge lift).
8.	ACTIVE/BYPASS SWITCH	Switch to activate or bypass (manual operation) the controller.
9.	TEMPERATURE CONTROLLER	Digital temperature control and indicator.
10.	WATER METER POWER SWITCH	Power switch for water meter.
11.	WATER METER START SWITCH	Starts water flow to kettle.
12.	WATER METER INTERRUPT SWITCH	Interrupts flow without resetting water meter.
13.	WATER METER CONTROL	Display and settings for water meter.
15.	MIXER BRIDGE	Encloses agitator motors.
16.	MAIN AGITATOR ARM	Provides most of the product movement.
17.	SECONDARY AGITATOR ARM	Provides reverse agitation and product lift in kettle.
18.	SECONDARY SPEED CONTROL KNOB	Controls speed of secondary agitator arm.
19.	FAUCET SPOUT	Delivers water to the kettle.
20.	HOT WATER VALVE	Turns on hot water.
21.	COLD WATER VALVE	Turns on cold water.
22.	VACUUM/PRESSURE GAUGE	Indicates steam pressure in PSI inside steam jacket as well as vacuum in inches of mercury
23.	POWER TILT CONTROL SWITCH	Used for tilting the kettle up or down. Replaced by hand tilt wheel on manual tilt units.
24.	DRAW OFF VALVE	Discharge valve for product in the kettle.
25.	HEAT INDICATOR LIGHT (GREEN)	When lit, indicates that the kettle burner is on. Cycles ON-OFF with elements.
26.	SOLID STATE TEMPERATURE CONTROL KNOB	This control allows the operator to adjust the kettle temperature in increments from 1 (Min.) to 10 (Max.). (see Temperature Range Chart).
27.	LOW WATER INDICATOR LIGHT	When lit, indicates that the kettle is low on water and will not operate in this (Red) condition. This will also light when the kettle is tilted.

OPERATING THE KETTLE



Intended Use:

Processing of food and pharmaceuticals in non-residential locations. Not for the making of dough or other heavy dough like products.

Intended Users:

- Supervised and trained staff during production periods.
- Trained maintenance and service personnel.

Removable component weights

Lbs (kg)	40 gal	60 gal	80 gal	100 gal
Main arm with blades	21 (9.5)	23 (10.4)	25 (11.3)	28 (12.7)
Baffle arm	7 (3.2)	7 (3.2)	8 (3.6)	10 (4.5)
Secondary arm	8 (3.6)	8 (3.6)	10 (4.5)	12 (5.4)
Screen	7 (3.2)	8 (3.6)	9 (4.1)	10 (4.5)
Air valve complete	12 (5.4)			
Air cylinder only	8 (3.6)			
Air valve body only	4 (1.8)			

Noise level

Noise level maximum 80 Decibels.

Mixing Arm Rotation Speeds

Arm	Speed (RPM)
Primary	0-40
Secondary	0-210

Rim (loading) heights

Rim heights are given below. It is up to owners of the equipment to ensure the operators are performing the loading in a safe and acceptable manner.

Size	Height - BV3 valve	Height - PVA3 valve
40	40.5 in (102.8 cm)	40.75 in (103.5 cm)
60	43.75 in (111.1 cm)	44.25 in (112.4 cm)
80	44.75 in (113.7 cm)	46.26 in (117.5 cm)
100	44.5 in (113.0 cm)	48.75 in (123.8 cm)

Emergency

In the event of a fire or other emergency:

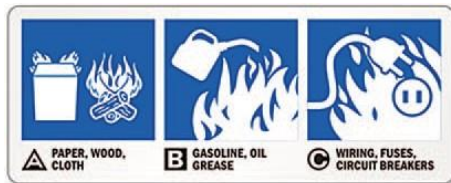

Turn off unit. Shut off power supplies including Electrical and Water (If safe to do so).

Using fire extinguishers is only recommended if you are trained and feel safe to do so. Use only Fire extinguishers rated ABC.

This is a pressure vessel and with a properly operating safety valve will not exceed rated pressures. Jacket contains water and trace amounts of rust inhibitor and/or antifreeze.

WARNING:



This unit has been fitted with a warning buzzer for bridge movement and a cover and screen to prevent contact with moving mixer arms. Do not remove or bypass these safeties.

1. Perform daily pre-startup inspection (See **Daily Pre-Startup Inspection** in **Preventive Maintenance**)
2. Preheat the kettle by turning the ON/OFF Temperature Control to the desired temperature setting. The Heat Indicator Light (Green) will remain lit, indicated the burner is on, until the temperature setting is reached. When the green light goes off, the burners are off, and preheating is complete.

NOTE: When cooking egg and milk products, the kettle should not be preheated, as products of this nature adhere to hot cooking surfaces.

3. Place food product into the kettle. The green Heat Indicator Light will cycle on and off indicating the burners are cycling on and off to maintain the set temperature.
4. When cooking is completed turn Temperature Control to the "OFF" position.
5. Pour the contents of the kettle into an appropriate container by tilting the kettle forward or using discharge valve.

NOTE: Cleaning should be completed immediately after cooked foods are removed.

Operating Suggestions

Cleveland Range Mixer Kettles are simple and safe to operate. The following tips will allow you to maximize the use of your new mixer.

If a mixer bridge is equipped with a temperature probe for a controller or thermometer, the probe must be submerged a minimum of 3" (8 cm) in the product for accurate readings.

Safety

As a safety precaution the MIXER SPEED CONTROL must first be turned to zero before unit will start to mix.

Always remember, like a cooking pot the kettles become very hot when cooking. Avoid contact with bare skin.

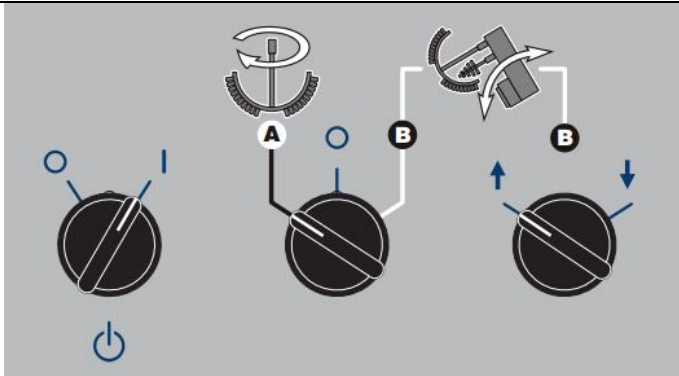

MAIN POWER SWITCH

MIX/LIFT SWITCH

UP/DOWN SWITCH

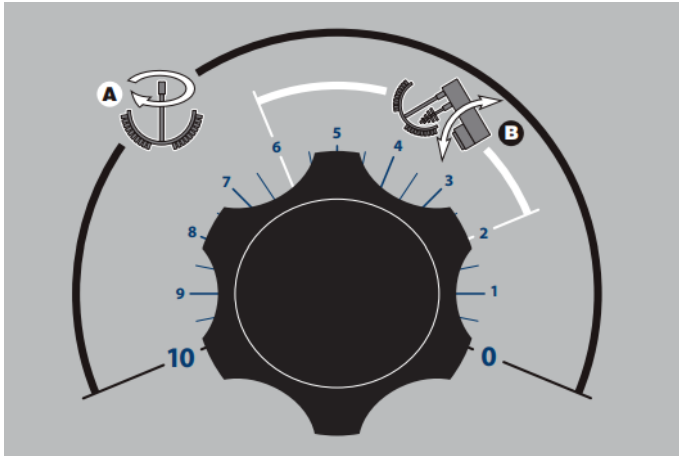

MIXER SPEED CONTROL SWITCH

GENERAL OPERATION

1. Turn MAIN POWER SWITCH on.
2. Turn Steam Control Valve to control heat kettle.

Lifting & Lowering Bridge

WARNING: Ensure FAUCET SPOUT is out of way before raising or lowering bridge.

1. Turn MIX/LIFT SWITCH to lift icon "B".
2. Turn MIXER SPEED CONTROL to "0" and back up to "5".
3. Turn and hold UP/DOWN SWITCH to up arrow to raise or down arrow to lower.

Mixing

1. Turn MIX/LIFT SWITCH to mix icon "A".
2. Turn MIXER SPEED CONTROL SWITCH to "0" and slowly adjust to desired speed.
3. Adjust SECONDARY SPEED CONTROL KNOB to desired speed.

Tilting Kettle

1. Raise MIXER BRIDGE and swing to side.
2. For manual tilt: Turn HANDWHEEL.
3. For power tilt: Turn POWER TILT CONTROL SWITCH.



WARNING: Do not tilt kettle when mixer agitators are in kettle bowl.

Product Discharge Valve

1. For butterfly valve: Push handle in and pull upwards to open.
2. For air valve: Turn Air Regulator Switch to open or close.

DIGITAL WATER METER OPERATING INSTRUCTIONS

(USED AFTER APRIL 2019)

NOTE: The digital counter has been pre-set at the factory and should operate satisfactory. If installing a new counter (or the configuration settings to your existing digital counter become corrupted) you must configure the digital counter as shown below (**Configuring a Digital Counter**) prior to operation.

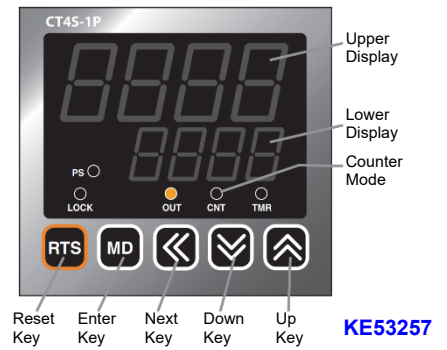

1. Turn POWER switch "ON".

2. Switch water to "Hot" or "Cold". (If option available).

3. To advance in setting value change mode, press key until the digit you want to change is flashing in the lower display window. Then use the or key to change the value of the flashing digit.

When all digits are selected (lower display window) for the required quantity of water press the **MD** key to complete the change of setting value and return to run mode. The selection will not be registered in the memory if **MD** is not pressed.



4. Locate delivery spout over desired kettle.

RESET CONTINUE



5. Turn START switch to **RESET**. Delivery will start at **0** and stop at preset volume.

INTERRUPT



6. To stop delivery at any time, turn INTERRUPT switch to ●.

RESET CONTINUE



7. To complete delivery after interrupting, turn START switch to **CONTINUE**.



8. Push **RST** button to reset counter to **0** without starting delivery.

Hot Cold



9. Select Hot or Cold water if this option is available.

Configuring a Digital Counter

This procedure is only necessary when installing a replacement counter or settings to existing counter become corrupted.

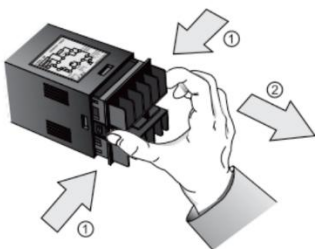

1. Power must be off.
2. Squeeze toward (1) and pull toward (2) as illustrated. (CTS/CTY Series)
3. Select input logic by using input logic switch (SW1) inside Counter/Timer.
4. Push case in opposite direction of (2).
5. Turn power on.

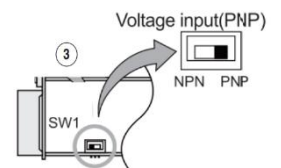

NOTE: Turn OFF the power before changing input logic. (PNP/NPN).



Editing Parameter Settings

After changing the switch position (see above instructions - **Configuring a Digital Counter**), edit the parameters as follows:

NOTE: The PS indicator light will turn off while the counter is in configuration mode.

1. Press and hold **MD** key for 3 seconds to enter parameter configuration mode. Use **MD** key to step through the parameters.
2. When the desired parameter description is shown in the upper display (see **Parameters Chart**), press  or  key to change the parameter.
3. When the desired setting is shown, press the **MD** key to move to the next parameter.
4. To exit configuration mode, press and hold **MD** key for 3 seconds.

Parameters Chart

Use **MD** key to step through Parameters



Parameter Description	Parameter Sign	Required Setting
Counter/Timer	[C-t]	CoUn
Input Mode	[In]	UP
Output Mode	[out.n]	C
Max. Counting Speed	[CPS]	30
Decimal Point	[dP]	----
Min. Reset Time	[rst]	20
Input Logic	[SIG]	PnP
Prescale Decimal Point	[SC.dP]	----.
Prescale Value	[SCL]	001.0
Start Point Value	[StPt]	0000
Memory Protection	[dAtA]	CLr
Key Lock	[LoCK]	L.oFF

Use  or  key to step to the Required Setting

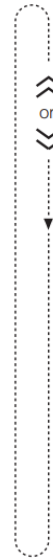

CLEANING INSTRUCTIONS

CARE AND CLEANING



Cooking equipment must be cleaned regularly to maintain its fast, efficient cooking performance and to ensure its continued safe, reliable operation. The best time to clean is shortly after each use (allow unit to cool to a safe temperature).

WARNINGS



Harsh Cleaners

Do not use harsh detergents or cleaners that are chloride-based, caustic, highly acidic, or contain quaternary salts.



Wire Brush & Scrapers

Do not use a metal bristle brush or scraper



Steel Pads

Steel wool shall never be used for cleaning the stainless steel.

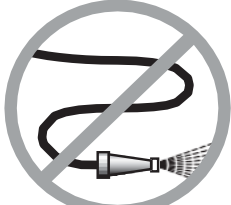

High Pressure Spray Hose

Unit should never be cleaned with a high pressure spray hose.



Stagnant Water

Do not leave water sitting in unit when not in use.

CLEANING INSTRUCTIONS

1. Turn unit off.
2. Remove drain screen (if applicable). Thoroughly wash and rinse the screen either in a sink or a dishwasher.
3. Prepare a warm water and mild detergent solution in the unit.
4. Remove food soil using a nylon brush.
5. Loosen food that is stuck to the kettle by allowing it to soak.
6. Drain unit.
7. Rinse interior thoroughly.
8. If the unit is equipped with a Tangent Draw-Off Valve, clean as follows:
 - a) Disassemble the draw-off valve first by turning the valve knob counter-clockwise, then turning the large hex nut counter-clockwise until the valve stem is free of the valve body.
 - b) In a sink, wash and rinse the inside of the valve body using a nylon brush.
 - c) Use a nylon brush to clean tangent draw-off tube.
 - d) Rinse with fresh water.
 - e) Reassemble the draw-off valve by reversing the procedure for disassembly. The valve's hex nut should be hand tight only.
9. If the unit is equipped with a Butterfly Valve, clean as follows:
 - a) Place valve in open position.
 - b) Wash using a warm water and mild detergent solution.
 - c) Remove food deposits using a nylon brush.
 - d) Rinse with fresh water.
 - e) Leave valve open when unit is not in use.
10. If the unit is equipped with an Air Valve, clean as follows:
 - a) Open product valve.
 - b) Disconnect air hoses.
 - c) Remove air cylinder.
 - d) Remove valve tee.
 - e) Remove all O-rings.
 - f) Clean air cylinder, do not submerge in water. Wipe clean and sanitize.
 - g) Clean and sanitize tee and O-rings.
 - h) Grease and reinstall O-rings.
 - i) Reinstall valve tee to kettle outlet.
 - j) Reinstall air cylinder to bottom of tee.
 - k) Reconnect air hoses.
 - l) Close valve and check for alignment.
11. Clean the scraper blades as follows:
 - a) Remove retaining ring and slide scraper blades off agitator arm.
 - b) Place parts in a pan of warm water to soak.
 - c) Clean in a sink, using a warm water and mild detergent solution.
 - d) Rinse with fresh water.
 - e) Allow to dry thoroughly on a flat, clean surface.
12. Using mild soapy water and a damp sponge, wash the exterior, rinse, and dry.

NOTES

- ⇒ For more difficult cleaning applications one of the following can be used: alcohol, baking soda, vinegar, or a solution of ammonia in water.
- ⇒ Leave the cover off when the kettle is not in use.
- ⇒ For more detailed instructions refer to Stainless Steel Equipment Care and Cleaning (www.nafem.org/resources/stainlesssteelfinal.doc) on Nafem's website (www.nafem.org).

DISPOSAL INSTRUCTIONS



This unit is recyclable. Do not dispose in landfill.

The unit may contain rust inhibitor and/or anti-freeze within the jacket. Drain unit and dispose following Federal, State, and local regulations.

The majority of the unit is composed of stainless steel. Other alloys and electrical components make up a small percentage of the total. Follow Federal, State, and local regulations for disposal.



PREVENTATIVE MAINTENANCE

FOR MAINTENANCE AND REPAIRS CONTACT YOUR AUTHORIZED MANITOWOC SERVICE AGENCY AND HAVE A QUALIFIED SERVICE TECHNICIAN MAINTAIN YOUR EQUIPMENT.



WARNING:



If for any reason this unit is not functioning correctly DO NOT OPERATE. Contact your authorized service agent.



DAILY PRE-STARTUP INSPECTION

1. Kettle tilts smoothly, handle is tight and kettle holds in any position (tilting models only).
2. Pressure gauge is in the green when unit is cold.
3. Green light comes on when unit is energized.
4. Red light comes on when unit is tilted (tilting models only)

SIX MONTH SERVICE INSPECTION

1. Perform daily startup inspection.
2. Gasket (G) around top cover is in good condition.
3. Tilt hand (H) wheel is tight.
4. **Grease bearings on both trunnions.**
5. Check for play in gears (adjust if required).
6. Fasteners securing panels are in place and tight.
7. **Perform pressure relief valve periodic test (see Pressure Relief Valve Testing).**
8. Adequate exhaust and makeup air is supplied to working area.
9. Check for hydraulic leaks.
10. Check safety systems have not been bypassed.

YEARLY SERVICE INSPECTION

1. Perform six month service inspection.
2. Replace hydraulic oil and filter.
3. Check kettle maximum temperature setting (see CALIBRATING PROCEDURE).
4. Perform safety inspection using SAFETY INSPECTION CHECKLIST found in the MAINTENANCE PROCEDURES.

TROUBLESHOOTING AND MAINTENANCE PROCEDURES



The following trouble shooting guide and maintenance procedures are meant to be used by qualified service technician.

ANY REPAIRS TO THE PRESSURE VESSEL MUST BE DONE BY A CERTIFIED PRESSURE VESSEL REPAIR SHOP AND ALL REPAIR METHODS AND MATERIALS MUST BE APPROVED BY THE MANUFACTURER.

For periodic maintenance recommendations see “Operators Manual”.

Extreme caution must be taken if unit is electrically energized for testing.

Remove power from the unit while servicing.

Ensure kettle is at room temperature and pressure gauge is showing zero or less pressure prior to removing any fittings.

DIAGNOSTIC GUIDE

This section contains servicing information intended for use by Authorized Service Personnel.

NOTE 1: If Fault Isolation Procedure is required, be sure to start at step #1.

NOTE 2: On table type kettles the entire control mounting panel may be removed from kettle control housing for easier troubleshooting and parts replacement.

PROBLEM A: Kettle is not heating at all (Kettle must be on and temperature control set).

Possible Causes:

- | | | |
|-----------------------------|------------------------------------|---------------------------------------|
| 1. No incoming power. | 5. Defective 12 VDC relay. | 10. Defective thermistor |
| 2. Kettle is tilted. | 6. Defective safety thermostat. | 11. Defective 240/16 VAC transformer. |
| 3. Low water condition. | 7. Defective contactor/s. | 12. Defective control box |
| 4. Defective ON/OFF switch. | 8. Defective potentiometer | 13. Defective elements. |
| | 9. Defective low water level probe | |

Fault Isolation Procedure

Step	Test
1	Is there proper incoming voltage at terminal block?
	Yes Go to step #2. No Correct external power supply problem.
2	Is the red LED illuminated?
	Yes Follow Reservoir Fill Procedure. If this does not correct the problem, go to Problem D. No Go to step #3.
3	Is the green LED illuminated
	Yes Go to step #4. No Go to step #7.
4	Do both contactors energize?
	Yes Check contactor contacts for pitting. Voltage across contactor terminals while in a closed position indicates a poor contact. Replace contactor/s as necessary. Check elements for short at ground or an open circuit. If element/s are defective contact the factory. Elements are not field replaceable. No Go to step #5.
5	Measure continuity across safety thermostat. Is it an open circuit?
	Yes Replace defective safety thermostat. No Go to step #6.

6	Is there 120 VAC present across the coils of the contactors?
	Yes Replace defective contactor/s. No Go to step #7.
7	Remove wire from low water level probe and ground it to the body of the kettle. Do the contactors now energize?
	Yes Clean or replace defective low water level probe. No Go to step #8.
8	Is there 16 VAC present at output of 16 VAC transformer?
	Yes Go to step #9. No Replace defective 240/16 VAC transformer.
9	Measure continuity of ON/OFF switch. Is it operating properly?
	Yes Go to step #10. No Replace defective ON/OFF switch.
10	Unplug control box and measure the resistance across potentiometer. Is it approximately 0 ohms at maximum setting and 50,000 ohms at minimum?
	Yes Go to step #11. No Replace defective potentiometer.
11	Remove edge connector from control box. While kettle is cold or thermistor is removed and allowed to cool, measure the resistance between edge connector's pin #2 and #7. Is it approximately 100,000 ohms?
	Yes Spray contact cleaner on control box terminal and edge connector. Try box again, if the problem still exists, replace defective control box. No Replace defective thermistor.

PROBLEM B: Kettle heats too slowly or not hot enough (NOTE: normal max operating pressure with an empty kettle is 30-35 psi.)

Possible Causes:

- | | | |
|------------------------------------|----------------------------|---------------------------|
| 1. Air in jacket requires venting. | 3. Defective potentiometer | 6. Defective control box. |
| 2. Defective safety thermostat. | 4. Defective thermistor | 7. Defective element/s. |
| | 5. Defective contactor/s. | |

Fault Isolation Procedure

Step	Test
1	In a cold state, does the pressure gauge read in the green zone?
	Yes Go to step #2. No There is air present in the jacket of the kettle. Follow Kettle Venting Procedure. If constant venting is required, there is a leak that should be corrected.
2	Do the contactors shut off too early? (before reaching normal maximum operating pressure)?
	Yes Go to step #3. No Check contactor contacts for pitting. Voltage across terminal of contactor while energized signifies a poor contact. Replace contactor/s as necessary. Check elements for short to ground or open circuit. If elements are defective, contact the factory. Elements are not field replaceable.
3	Does the green LED remain illuminated after the contactors shut off?
	Yes Replace defective safety thermostat No Go to step #4.
4	Unplug control box and measure the resistance across potentiometer. Is it approximately 0 ohms at maximum and 50,000 ohms at minimum setting?
	Yes Go to step #5. No Replace defective thermistor
5	Remove kettle thermistor and allow to cool. Remove edge connector from control box. Test resistance across edge connector's pins #2 and #7. Is it approximately 100,000 ohms?
	Yes Go to step #6. No Replace defective thermistor
6	Turn the potentiometer on the control box clockwise to increase the maximum operating temperature. Does the kettle now achieve maximum operating pressure of 3-35 psi in an empty kettle?

Yes	Kettle is operating correctly.
No	Spray contact cleaner on control terminals and edge connectors. Try box again. If problem still exists, replace defective control box.

PROBLEM C: Kettle is overheating.

Possible Causes:

1. Defective thermistor.
2. Defective potentiometer.
3. Defective 12 VDC relay.
4. Defective control box.

Fault Isolation Procedure

Step	Test
1	Does the green LED turn off even though the contacts remain energized? Yes Replace defective 12 VDC relay. No Go to step #2.
2	Unplug the control box and measure the resistance across the potentiometer. Is the resistance approximately 0 ohms at maximum and 50,000 ohms at minimum setting? Yes Go to step #3. No Replace defective thermistor.
3	Remove the kettle thermistor and allow to cool. Remove edge connector from control box. Test resistance across edge connector's pins #2 and #7. Is it approximately 100,000 ohms? Yes Go to step #4. No Replace defective thermistor.
4	Turn the potentiometer on the control box counter-clockwise to decrease the maximum operating temperature. Does the kettle continue to overheat? Yes Spray contact cleaner on control box terminal and edge connector. Try box again. If problem still exists, replace defective control box. No Kettle is operating correctly.

PROBLEM D: Red LED remains illuminated even though water has been added.

Possible Causes:

1. Defective low water level probe
2. Defective control box

Fault Isolation Procedure

Step	Test
1	Remove wire from low water level probe and ground the wire to the body of the kettle. Does the red LED turn off? Yes Replace or clean defective low water level probe. No Spray contact cleaner on control box terminals and edge connector. Try box again. If problem still exist, replace defective control box.

SAFETY INSPECTION CHECKLIST

NOTE: The following instructions are intended for use by qualified service personnel.

The following steps should be completed **IN SEQUENCE**.



A. KETTLE PREPARATION

1. Disconnect main power at fused disconnect switch.
2. Kettle must be cold. If necessary, add water to kettle pot to cool unit.
3. The pressure gauge should now show a vacuum and have no indication of leakage. If gauge looks damaged replace gauge.
4. Gauge must be showing a vacuum prior to proceeding. If not check for leaks, and repair kettle prior to proceeding. Refer to REFERENCE SECTION (KETTLE VENTING INSTRUCTIONS).



Pressure Gauge in Vacuum

B. MECHANICAL CHECKS

1. Inspect controls, replace damaged seals, switches, LED's etc..
2. Remove the console cover and check that the seal is not cracked or split. Replace seal, screws, missing or worn nylon anchor nuts. **Leave cover off.**
3. Remove the kettle bottom cover and check that the seal is not cracked or split. **Leave cover off.**
4. For units with tilt crank
 - a) Check that the kettle tilts smoothly. If there is excess play adjust the worm to gear clearance with Locking Nuts or Adjusting Screw as required.
 - b) Check that there is no excessive wear in the trunnion bearings.
 - c) Apply grease to gear teeth and bearings.

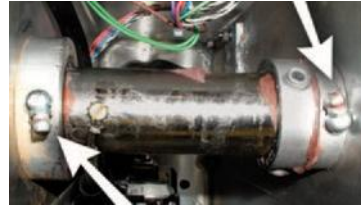

Grease Nipples

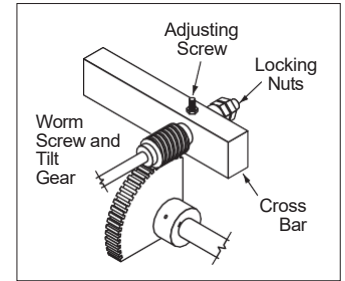

Illustrations Inverted for Clarity

C. CONTACTOR TEST

1. Remove power to unit.
2. Remove nut holding component mounting plate to console.
3. Pull plate out and place on top of console. (Depending on how the installer wired the kettle you may have to remove the supply wire and reconnect).
4. Physically push in on contacts of each contactor to check for free movement. Replace contactor(s) if required.



D. LOW WATER LEVEL PROBE – FUNCTIONAL TEST

1. Turn main power on at fused disconnect switch. **Installation Check**
2. Turn kettle on and set temperature to maximum.
3. Green light will come on and contactors close.
4. Tilt kettle over. After approximately a five-second delay the red light will come on, green light goes off and the contactors will disengage.
5. Turn kettle upright. Green light will come back on and contactors reengage.
6. Turn kettle off
7. If unit does not function as above, make required repairs.
8. Disconnect main power at fused disconnect switch.



✓ Probe properly attached

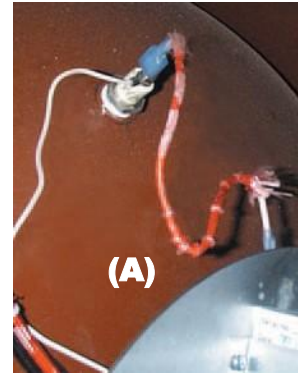

✗ Probe bypassed by (A) running an additional wire

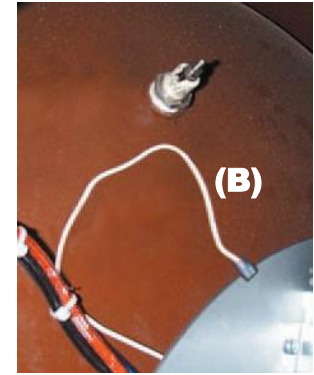

✗ Probe bypassed by (B) grounding the connecting wire

E. SAFETY THERMOSTAT

Installation Check:

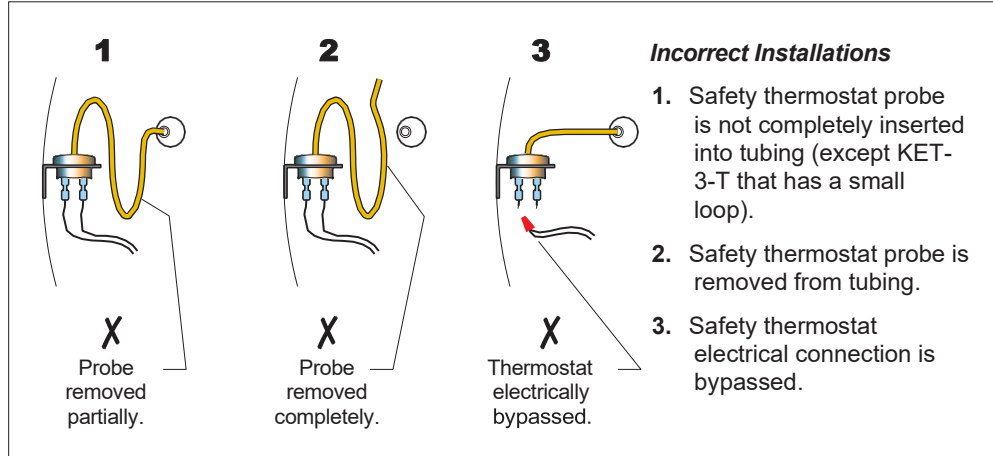
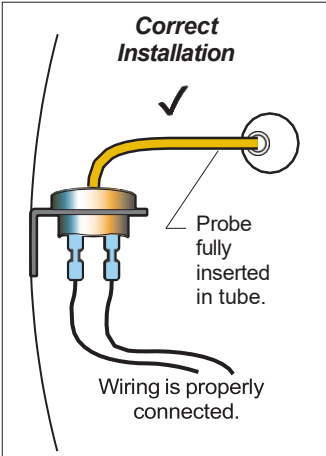

F. SAFETY VALVE

Installation Check:

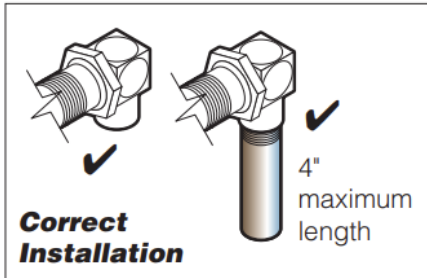

The above illustrations show the variations of factory installed Safety Valves. **Any modifications are unacceptable.**

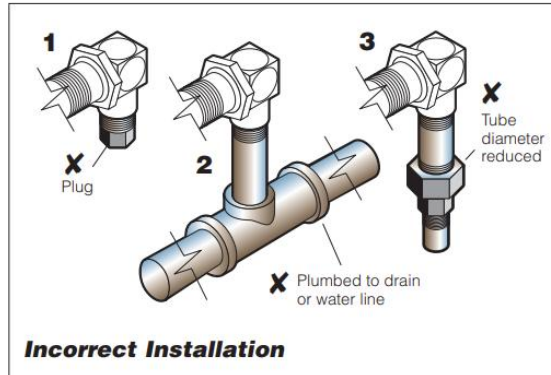

Physical Check:

1. Check that the PSI (kPa) rating on the valve matches MAWP (maximum allowable working pressure) on the plate welded to the kettle.
2. Check that the Safety Valve has a "UV" stamp.
3. Check that the valve is not damaged in any way.

If any of the above criteria is not met, replace valve.

Pressure Relief Valve Periodic Testing Procedure

1. With the kettle empty, set temperature to maximum 266°F (130°C). Allow the kettle to heat until the unit cycles off.
2. Turn the knob to set temperature to "0" (Off) and disconnect main power at fused disconnect switch.
3. Stand to the side of the pressure relief valve discharge tube and pull valve open for a maximum of one second. Repeat test three to four times. Each time the mechanism should move freely and be accompanied by a rapid escape of steam.

If valve appears to be sticking replace pressure relief valve.

If foreign material is discharged, then drain kettle and replace pressure relief valve.

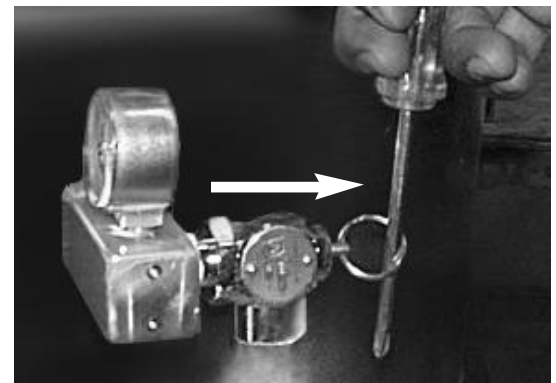

G. CALIBRATING PROCEDURE

1. Kettle must be empty when this procedure is executed.
2. Ensure the unit has a vacuum before you begin calibrating procedures. If unit requires venting see REFERENCE SECTION (KETTLE VENTING INSTRUCTIONS).
3. Turn kettle ON and set temperature to maximum 266°F (130°C).
4. Allow the unit to cycle twice (the green light must go on and off).
5. Check temperature of the inner kettle surface with a digital surface thermometer. For accurate readings move probe around bottom of kettle to locate the hottest location.
6. Temperature should be between 260°F (127°C) and 265°F (129°C). Pressure gauge should read between 20-28 PSI (138-193 kPa).
7. Using a screwdriver adjust temperature by turning the potentiometer on the black box. Turn very little. Turn clockwise to INCREASE and counter-clockwise to DECREASE temperature.

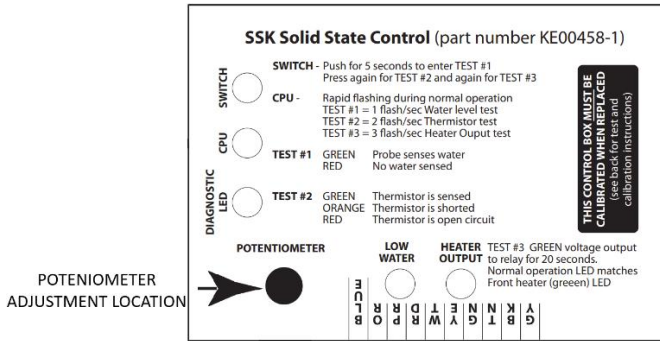
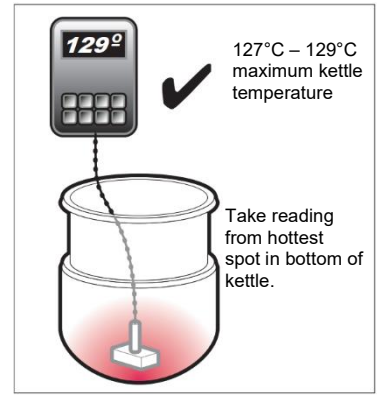

8. Allow the unit to cycle twice.
9. Re-check temperature.
10. Repeat steps 7 - 9 until unit is calibrated.

REPAIRING LEAKS IN STEAM JACKETED KETTLE FITTINGS

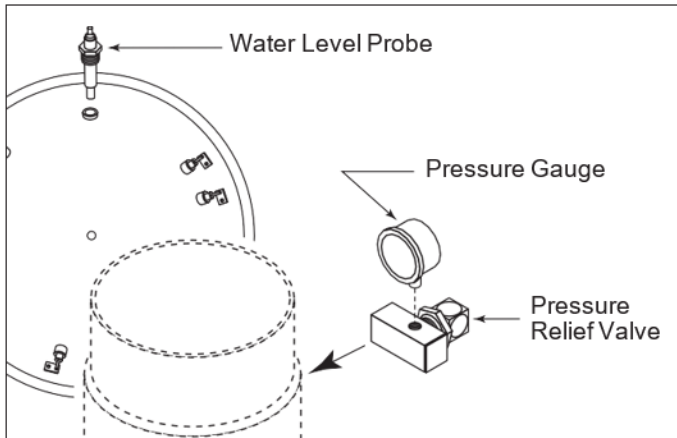

If unit will not hold a vacuum the most likely cause is a leak at one of the fittings. Often, the easiest way to eliminate a leak is reseal the suspect areas.

1. Water Level Probe Remove, clean threads, apply teflon thread sealant and reinstall.
2. Pressure Relief Valve **A/** Inspect for signs of leaks. Replace if required.
B/ Remove, clean threads, apply teflon thread sealant and reinstall.
3. Pressure Gauge **A/** Inspect face of gauge. If it contains moisture on the inside of face replace.
B/ Remove, clean threads, apply teflon thread sealant and reinstall.



5. Remove wire from ground lug.
6. Remove thermistor from tube.



7. Add new "eye" connector to one of the thermistor leads and fasten to ground lug.



8. Connect orange wire to the other thermistor lead and fasten with pigtail connector.



9. Insert thermistor as far as possible into tube and hold in place. While holding add silicon to secure thermistor into tube. Ensure silicon completely surrounds tube and thermistor.
10. Replace covers, reconnect power and test operation.

THERMISTOR REPLACEMENT

1. Disconnect main power at fused disconnect switch.
2. Remove bottom cover.



3. Locate thermistor.



4. Cut pigtail connection off.

KETTLE JACKET CLEANOUT AND PASSIVATION PROCEDURES

The following procedure should be performed at least once every three years to prevent possible corrosion and ensure the optimum life of the kettle.



DANGER:



Rust inhibitor can be dangerous. read label and follow safety instructions.

WARNING:



Improper refilling of kettle jacket will result in irreversible damage to unit.

RUST INHIBITOR

Use a "radiator rust inhibitor" that can be purchased at your local automotive centre. It should not contain any anti-freeze and preferably no lubricant.

To ensure satisfactory mixing follow the manufacturer's instructions.

DISPOSAL - Follow all Federal, State and local codes when disposing of product.

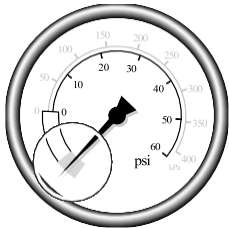

1. Ensure kettle is at room temperature and pressure gauge showing zero or less pressure.
2. Shut off power to the kettle at the fused disconnect switch.

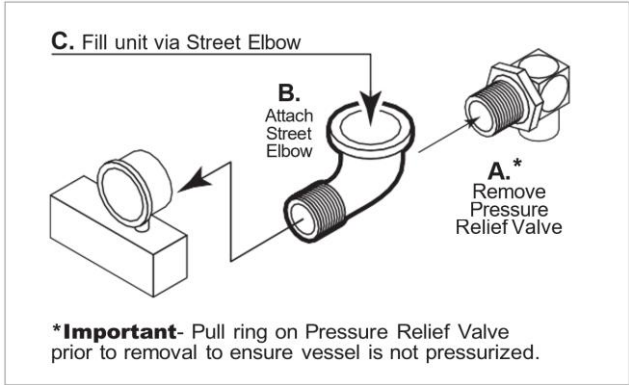

3. Pull Pressure Relief Valve (A) open to ensure vessel is not pressurized.
4. Remove Pressure Relief Valve (A).
5. Replace Pressure Relief Valve (A) with Street Elbow (B).
6. Add Spring Water (C) through the Street Elbow (B), using a funnel if necessary. Refer to SPRING WATER REQUIREMENTS chart for the proper amount required.
7. Apply a thread sealant (i.e. Teflon tape) to the Pressure Relief Valve's (A) thread and replace.
8. Restore power to unit at the fused disconnect switch.
9. The kettle must now be vented. (Refer to the KETTLE VENTING INSTRUCTIONS).

KETTLE VENTING INSTRUCTIONS

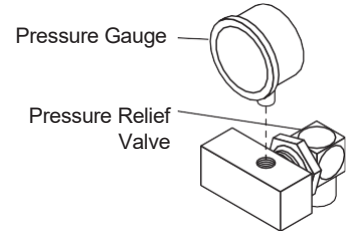
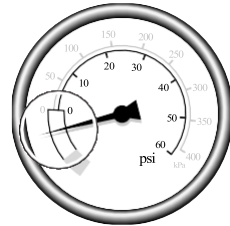

The following venting procedure should be followed when the Vacuum/Pressure Gauge needle is in the "VENT AIR" zone:

NOTE: Check for and eliminate leaks prior to venting (See REPAIRING LEAKS IN STEAM JACKETED KETTLE FITTINGS).

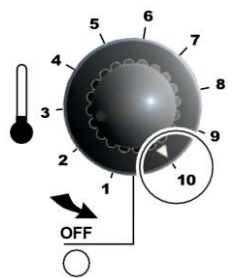

1. Set On-Off Switch/Temperature Control to "10" (Max.). Heat the empty kettle until unit cycles off.



2. Vent kettle by pulling safety valve ring 8-10 times in short 2-3 second blasts with a 5 second interval between pulls. **NOTE:** If unit cycles ON, stop venting and wait for kettle to cycle OFF before continuing.

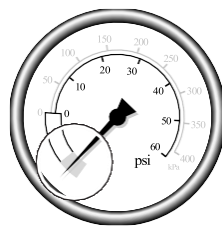

3. Turn kettle OFF. Add cold water to kettle until its surface temperature is below 100°F. The pressure gauge needle should be in the green zone, indicating a vacuum in the kettle's jacket.

HINGE ADJUSTMENT INSTRUCTIONS

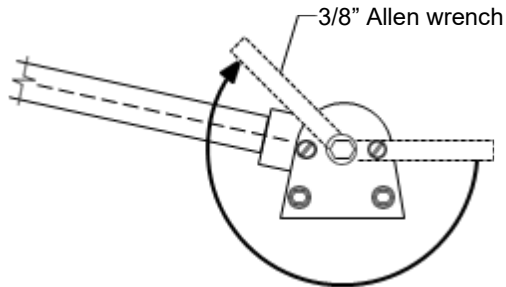

1. Insert 3/8" Allen wrench.
2. Turn clockwise to relieve tension on spring.
3. While tension is released remove one of the two slotted screws.
4. To prevent Allen wrench from springing back abruptly while the second slotted screw is removed, insert a pin (approximately 1/8") in the hole where the first slotted screw was removed from.
5. Remove second slotted screw.
6. While holding Allen wrench remove pin.
7. Turn Allen wrench clockwise to tighten or counter-clockwise to loosen tension to produce desired effect.
8. Re-insert pin in one of the two holes.
9. Tighten one slotted screw in the other hole (it may be necessary to turn Allen wrench slightly to align holes).
10. Remove pin and repeat step number 9 for other slotted screw.

SSK SOLID STATE CONTROL TEST INSTRUCTIONS

SSK Solid State Control (part number KE00458-1)

<p><input type="radio"/> SWITCH - Push for 5 seconds to enter TEST #1 Press again for TEST #2 and again for TEST #3</p> <p><input type="radio"/> CPU - Rapid flashing during normal operation TEST #1 = 1 flash/sec Water level test TEST #2 = 2 flash/sec Thermistor test TEST #3 = 3 flash/sec Heater Output test</p> <p><input type="radio"/> TEST #1 GREEN Probe senses water RED No water sensed</p> <p><input type="radio"/> TEST #2 GREEN Thermistor is sensed ORANGE Thermistor is shorted RED Thermistor is open circuit</p> <p>POTENTIOMETER</p> <p><input type="radio"/></p>	<p>LOW WATER</p> <p><input type="radio"/></p>	<p>HEATER OUTPUT</p> <p><input type="radio"/> TEST #3 GREEN voltage output to relay for 20 seconds. Normal operation LED matches Front heater (green) LED</p>
--	--	--

1. If required remove board from holding bracket for better access.
2. Turn unit on and set to 10 (maximum).
3. Push and hold the SWITCH button for approximately 5 seconds until the CPU starts to flash 1 flash/second. You are now in TEST #1. Output to 12v relay is disabled. With kettle upright the DIAGNOSTIC LED should be green, with kettle tilted it should be red.
4. Push SWITCH button. The CPU starts to flash 2 flash/second. You are now in TEST #2. Check the DIAGNOSTIC LED for indication of the temperature probe status.
5. Push SWITCH button. The CPU starts to flash 3 flash/second. You are now in TEST #3. The HEATER OUTPUT LED should light for 20 seconds and power to the relay should energize the 12v relay for the heat source.

After 20 seconds test mode is exited and unit reverts to normal operation

RESERVOIR FILL PROCEDURES

The kettle's water level must be maintained at the proper level to submerge the heater elements. Under normal operating conditions, the sealed water reservoir should never require the addition of water.

If the red "low water" light comes on during use (while the kettle is in an upright position), the water level has reached a critically low level. The low water protection control has automatically shut off the heater elements. The following procedure must be completed before further use:

NOTE: Have a qualified service technician repair the leakage problem and add water to the unit. Ensure that the red "low water" light is on when the kettle is upright. On tilting kettles, it is normal for the red light to come on when the kettle is in a tilted position, as the elements are not submerged in water at this point.

CAUTION: Only a mixture of distilled water and rust inhibitor should be used when adding water to a partially filled water reservoir. Local tap water conditions may cause kettle damage which is not covered under warranty. Rust inhibitor is purchased locally. Read directions and do not exceed manufacturer's recommendation (excessive rust inhibitor can also cause solidification).

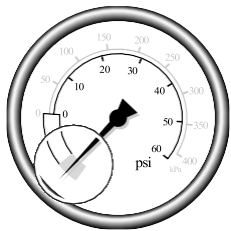

1. Ensure kettle is at room temperature and pressure gauge showing zero or less pressure.
2. Shut off power to the kettle at the fused disconnect switch.

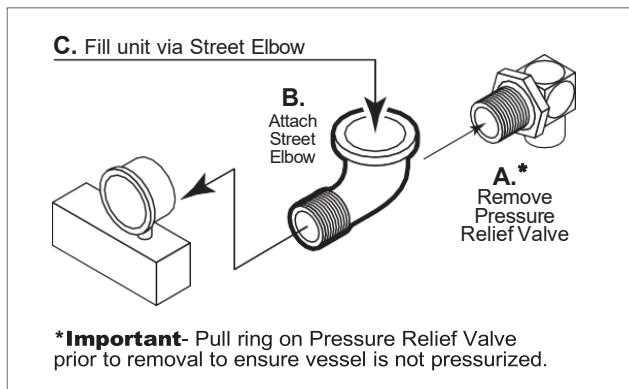

3. Pull Pressure Relief Valve (A) open to ensure vessel is not pressurized.
4. Remove Pressure Relief Valve (A).
5. Replace Pressure Relief Valve (A) with Street Elbow (B).
6. Add Spring Water (C) through the Street Elbow (B), using a funnel if necessary. Refer to SPRING WATER REQUIREMENTS chart for the proper amount required.
7. Apply a thread sealant (i.e. Teflon tape) to the Pressure Relief Valve's (A) thread and replace.
8. Restore power to unit at the fused disconnect switch.
9. The kettle must now be vented. (Refer to the KETTLE VENTING INSTRUCTIONS).

SPRING WATER REQUIREMENTS

Kettle Capacity	When Red "Low Water Light" comes on, add Distilled Water	When the Reservoir is Completely Empty, Add Distilled Water
3 gallon	50 ounces	120 ounces
6 gallon	70 ounces	160 ounces
12 gallon	120 ounces	2 gallon
20 gallon	1 gallon	3 gallon
25 gallon	1.0 gallon	3.8 gallon
30 gallon	1.5 gallon	4.3 gallon
40 gallon	2.0 gallon	4.8 gallon
60 gallon	2.1 gallon	5.8 gallon
80 gallon	2.6 gallon	6.5 gallon
100 gallon	2.8 gallon	7.3 gallon

DRAINING PROCEDURE



WARNING: THE FUSED DISCONNECT SWITCH MUST BE OFF BEFORE REMOVING THE KETTLES BOTTOM COVER.

Draining procedure

1. Pull pressure relief valve to ensure there is no pressure within the kettle jacket.
2. Remove bottom covers.
3. Remove low water level probe and allow water to drain.
4. To rinse kettle jacket:
 - a) On tilting kettles fill jacket from low water probe fitting.
 - b) On stationary kettles:
 1. Replace low water probe.
 2. Remove pressure relief valve and replace with street elbow.
 3. Using a small funnel (one made of paper works great) slowly pour water into the kettle.
5. Allow kettle to drain again.
6. Repeat until water drains clear.

REFILLING UNIT AFTER DRAINING

1. Apply a thread sealant (i.e. Teflon tape) to the water level probe threads and replace.
2. Follow RESERVOIR FILL PROCEDURES

LUBRICATION

Lubricate the following parts every three months to ensure smooth operation and reduce wear.

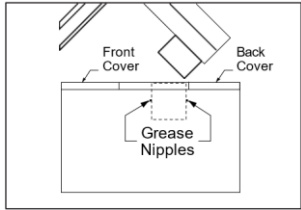

MIXER BRIDGE HOUSING

There are two grease nipples on the mixer bridge swivel housing which are accessed by removing the front and back covers on the 18" console.

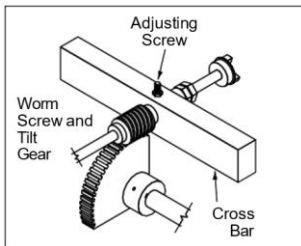

TRUNNION HOUSING, WORM SCREW AND TILT GEAR

These parts are accessed through the front cover on the 18" console.

Apply grease to gear teeth. Check for excessive play and adjust with adjusting screw located on top of cross bar.

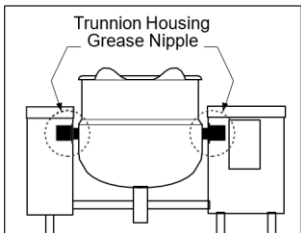

KETTLE TRUNNIONS

Accessed via the top covers on the 10" and 18" consoles. Each has two grease nipples.

HYDRAULIC OIL REPLACEMENT PROCEDURE

One of the most important maintenance tasks is to change the hydraulic oil yearly. Under heavy usage the oil should be changed every nine months. It is important to change the oil regularly to prevent its breakdown which leads to the damaging of components.

The oil filter should be changed at the same time as the hydraulic oil. A clean filter prevents particles from damaging the other components in the system.

Replace the hydraulic fluid as follows:

- ⇒ Disconnect power to unit.
- ⇒ Remove the front top panel on the main console.
- ⇒ Remove chrome vent cap from breather pipe located beside electric motor.
- ⇒ Remove plug bolt from bottom left front corner of main console to drain oil into your catch pail.
- ⇒ Remove oil filter.
- ⇒ Replace plug bolt.
- ⇒ Refill unit through breather pipe using approximately 12 U.S. gallons of Tellus 32 hydraulic oil (oil should be 6 1/2" deep in tank).
- ⇒ Install new oil filter (Part# SE50094).
- ⇒ Replace chrome vent cap and front top panel.
- ⇒ Reconnect power to unit.
- ⇒ Run unit to remove any air in the lines.

NOTE: Mixer may run rough and noisy for one or two hours if air has become trapped in the line.

RE-INSTALLING SPEED CONTROL CABLE

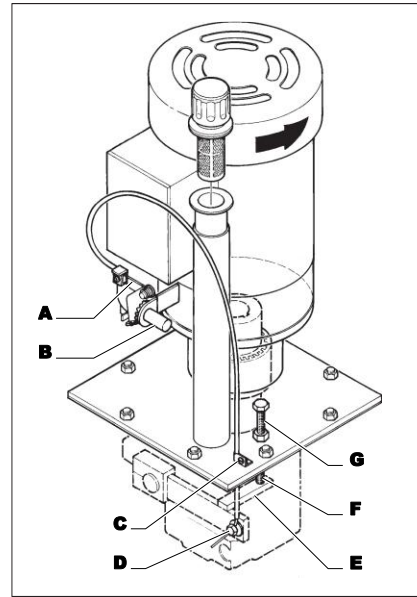

1. Turn sprocket of speed control so that wire "A" is fully extended towards shaft "B".
2. Insert end of cable through bracket "C".
3. Insert wire so it protrudes approximately 1/2" to 5/8" through hole in bolt "D". Tighten bolt and bend end of wire.
4. Bring pump arm "E" up until it hits stop bolt "F" and tighten screw "C".
5. Reassemble unit. Speed control knob will go on pointing toward minimum setting.
6. Turn mixer on with speed control set at minimum setting.
7. If scraper arm is turning, loosen nut "G" and back stop bolt "F" off a few turns. Next loosen screw "C" and slowly pull up cable until scraper arm stops turning. Retighten screw "C". Gently turn stop bolt "F" down until it hits arm. Lock in place by tightening nut "G".
8. Scraper arm should now go from no rotation to fast rotation by turning speed control knob.

NOTE: Mixer may run rough and noisy for one or two hours if air has become trapped in the line.

AIR LINE LUBRICATOR OIL FILLING PROCEDURE

1. Disconnect air supply and bleed system.
2. Remove cover on console
3. Check for oiler location.
4. Inspect oil level in bowl.
5. Remove filler cap.
6. Add mineral oil as required.
7. Replace filler cap and console cover.

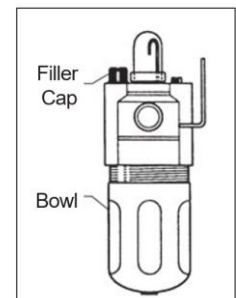

Every new piece of Welbilt Foodservice equipment comes with KitchenCare® and you choose the level of service that meets your operational needs from one restaurant to multiple locations

StarCare – Warranty & lifetime service, certified OEM parts, global parts inventory, performance audited

ExtraCare – CareCode, 24/7 Support, online/mobile product information

LifeCare – Install & equipment orientation, planned maintenance, KitchenConnect™, MenuConnect®

Talk with KitchenCare® • 1-844-724-CARE • www.mtwkitchencare.com



To learn how Welbilt Foodservice and its leading brands can equip you, visit our global web site at www.welbilt.com, then discover the regional or local resources available to you.