

Service Manual

Convotherm Combination Oven-Steamer

MODELS: Gas 20.20



OGS-20.20



OGB-20.20



Enodis

1333 East 179th St., Cleveland, Ohio, U.S.A. 44110

Phone: (216) 481-4900 Fax: (216) 481-3782
Visit our web site at www.clevelandrange.com

FOR THE INSTALLER

FOR YOUR SAFETY

Do not store or use gasoline or other flammable vapors or liquids in the vicinity of this or any other appliance.

WARNING

Improper installation, adjustment, alteration, service or maintenance can cause property damage, injury or death. Read the installation, operating and maintenance instructions thoroughly before installing or servicing this equipment.

NOTICE

Post instructions to be followed if the user smells gas.
Display the instructions in a prominent location.
All users of this equipment must understand the instructions.
Obtain the instructions from the local gas supplier.
Failure to follow the instructions if there is a gas leak can cause death, injury, and/or property damage.

WARNING

Disconnect power at the main external power switch before servicing or repairing a Combi. Failure to disconnect power can result in death, injury, and property damage.

ALL SERVICE MUST BE PERFORMED BY A QUALIFIED CLEVELAND RANGE AUTHORIZED TECHNICIAN.

WARNING

Do not connect the Combi Oven-Steamer drain connection to any drain material that cannot sustain 140° Fahrenheit. Using drain material that cannot withstand 140° Fahrenheit can result in injury, equipment damage, and property damage.

This Installation Manual is a part of your new Combi Oven-Steamer. You must keep and maintain it for the entire life span of your Combi and pass it on to the next owner of the Combi.

KEEP THIS MANUAL FOR REFERENCE

This manual may be subject to new technical developments, modifications, and unforeseen errors.

DO NOT OPERATE OR ATTEMPT TO OPERATE THIS APPLIANCE OR ANY ACCESSORIES WITHOUT READING COMPLETELY AND FULLY UNDERSTANDING THIS MANUAL

For caster equipped Combis: Per separate instructions, connect the strain relief (restraining device) and complete any remaining installation procedures BEFORE starting the Combi.

Convotherm by Cleveland Combi Oven-Steamers are intended for other than household use.

Cleveland STATEMENT OF POLICIES

LIMITED WARRANTY

CLEVELAND RANGE products are warranted to the original purchaser to be free from defects in materials and workmanship under normal use and service for the standard warranty period of one year from date of installation or 18 months from date of shipment, whichever comes first.

CLEVELAND RANGE agrees to repair or replace, at its option, f.o.b. factory, any part which proves to be defective due to defects in material or workmanship during the warranty period, providing the equipment has been unaltered, and has been PROPERLY INSTALLED, MAINTAINED, AND OPERATED IN ACCORDANCE WITH THE CLEVELAND RANGE OWNER'S MANUAL.

CLEVELAND RANGE agrees to pay any FACTORY AUTHORIZED EQUIPMENT SERVICE AGENCY (within the continental United States, and Hawaii) for reasonable labor required to repair or replace, at our option, f.o.b. factory, any part which proves to be defective due to defects in material or workmanship, during the labor warranty period. This warranty includes travel time not to exceed two hours and mileage not to exceed 50 miles (100 miles round-trip), BUT DOES NOT INCLUDE POST START-UP, TIGHTENING LOOSE FITTINGS, MINOR ADJUSTMENTS, MAINTENANCE, CLEANING OR DESCALING.

The standard labor warranty allows factory payment of reasonable labor required to repair or replace such defective parts. Cleveland Range will not reimburse the expense of labor required for the repair or replacement of parts after the standard warranty period, unless an Extended Labor Warranty Contract has been purchased to cover the equipment for the balance of the warranty period from the date of equipment installation, start-up, or demonstration.

PROPER INSTALLATION IS THE RESPONSIBILITY OF THE DEALER, THE OWNER-USER, OR INSTALLING CONTRACTOR, AND IS NOT COVERED BY THIS WARRANTY. Many local codes exist, and it is the responsibility of the owner and installer to comply with these codes. Cleveland Range equipment is built to comply with applicable standards for manufacturers, including UL, ANSI, NSF, ASME/Ntl. Bd., CSA, and others.

BOILER (Steam Generator) MAINTENANCE IS THE RESPONSIBILITY OF THE OWNER-USER AND IS NOT COVERED BY THIS WARRANTY. The use of good quality feed water is the responsibility of the Owner-User (see Water Quality Recommendations below). THE USE OF POOR QUALITY FEED WATER WILL VOID EQUIPMENT WARRANTIES. Boiler maintenance supplies, including boiler hand hole gaskets, are not warranted beyond the first 90 days after the date the equipment is placed into service. Preventive maintenance records must be available showing descaling per applicable Cleveland Operator Manual for Boiler Proration Program considerations.

WATER QUALITY RECOMMENDATIONS

TOTAL DISSOLVED SOLIDS	less than	60 parts per million
TOTAL ALKALINITY	less than	20 parts per million
SILICA	less than	13 parts per million
CHLORIDE	less than	30 parts per million
pH FACTOR greater	than	7.5

The foregoing shall constitute the sole and exclusive remedy of original purchaser and the full liability of Cleveland Range for any breach of warranty. THE FOREGOING IS EXCLUSIVE AND IN LIEU OF ALL OTHER WARRANTIES, WHETHER WRITTEN, ORAL, OR IMPLIED, INCLUDING ANY WARRANTY OF PERFORMANCE, MERCHANTABILITY, OR FITNESS FOR PURPOSE, AND SUPERSEDES AND EXCLUDES ANY ORAL WARRANTIES OR REPRESENTATIONS, OR WRITTEN WARRANTIES OR REPRESENTATIONS, NOT EXPRESSLY DESIGNATED IN WRITING AS A "WARRANTY" OR "GUARANTEE" OF CLEVELAND RANGE MADE OR IMPLIED IN ANY MANUAL, LITERATURE, ADVERTISING BROCHURE OR OTHER MATERIALS.

CLEVELAND RANGE'S liability on any claim of any kind, including negligence, with respect to the goods or services covered hereunder, shall in no case exceed the price of the goods or services, or part thereof, which gives rise to the claim. IN NO EVENT SHALL CLEVELAND RANGE BE LIABLE FOR SPECIAL, INCIDENTAL, OR CONSEQUENTIAL DAMAGES, OR ANY DAMAGES IN THE NATURE OF PENALTIES.

GENERAL INFORMATION ABOUT COMBIS

A. PRODUCT INFORMATION

Cleveland Range, LLC assigns two product identification numbers to each Combi: a model number and a serial number. The model number identifies the product characteristics. The serial number identifies the individual Combi.

1. Model Number

- This manual covers the installation of the OEB and OES model gas powered Combis.
- Model Number Key: "O" stands for the Combi series Oven, "E" or "G" designates Electric or Gas. "B" designates Steam Generator, and "S" designates Spritzer. The first number designates the number of shelves in the oven rack. The second number is either ".10" for 12" X 20" steam table pans or ".20" for 18" X 26" full size sheet pans. For further information, contact your Convotherm by Cleveland sales representative or Cleveland Range.

2. Serial Number and Equipment Record

During manufacture, Combis are assigned individual serial numbers. Please provide the following information when you contact Cleveland Range or a qualified Cleveland Range authorized service representative:

Serial Number _____
(Write the Serial Number of your Combi here.)

Model Number _____
(Write the Model Number of your Combi here.)

3. Product Information Plate

The Product Information Plate on the left side of the Combi lists the model, serial number, gas, electric, and wiring requirements of the Combi. Figure 1-1 illustrates a typical Product Information Plate.

GAS-FIRED	Enodis®	CLEVELAND RANGE, LLC
UL LISTED		CLEVELAND, OHIO
ANSI Z83.11 <input type="checkbox"/> a	MODEL NO	<input type="text" value="6.20 OGB"/>
• CSA 1.8 <input type="checkbox"/> a-2004	SERIAL NO	<input type="text" value="WC 62092-05F-02"/>
FOOD SERVICE EQUIPMENT 16SY	OVEN	<input type="text" value="68,000"/> BTU PER HR
	STEAM GENERATOR	<input type="text" value="61,000"/> BTU PER HR
	MANIFOLD PRESSURE	<input type="text" value="FACTORY SET"/> W.C.
	<input type="checkbox"/> NATURAL <input type="checkbox"/> GAS	<input type="text" value="1000"/> BTU PER CU FT
	FOR USE ON COMBUSTIBLE FLOORS, WITH THE FOLLOWING MINIMUM CLEARANCES TO COMBUSTIBLE AND NONCOMBUSTIBLE CONSTRUCTION.	
	BACK <input type="text" value="2"/> IN	RIGHT SIDE <input type="text" value="2 1/2"/> IN LEFT SIDE <input type="text" value="4"/> IN
	VOLTS <input type="text" value="120"/> PHASE <input type="text" value="1"/> HZ <input type="text" value="60"/> AMPS <input type="text" value="11.7"/>	
	CAUTION: FOR SUPPLY CONNECTION USE ONLY COPPER WIRE SUITABLE FOR AT LEAST <input type="text" value="160"/> °C	
	INTENDED FOR OTHER THAN HOUSEHOLD USE FOR INSTALLATION UNDER VENTILATION HOOD ONLY	

Figure 1-1
Typical Product Information Plate

INSTALLATION INSTRUCTIONS

A. GENERAL

This equipment should be installed only by qualified, professional plumbers, pipe fitters, and electricians.

1. The installation of this Combi must conform with:
 - a. The National Fuel Gas Code, ANSI Z223.1 / NFPA 54 (latest edition), or the Natural Gas and Propane Installation Code CSA B1 49.1 as applicable.
 - b. The National Electrical Code, ANSI/NFPA 70 (latest edition), or the Canadian Electrical Code, CSA C22.2 as applicable.
 - c. The Food Service Sanitation Manual of the Food and Drug Administration (FDA).
 - d. All applicable national, state, and local laws, codes, and regulations.
2. This equipment is to be installed to comply with the applicable federal, state, or local plumbing codes.
3. Installation instructions must be read in their entirety before starting installation of a Combi.
4. Install the Combi according to the policies and procedures outlined in this manual.

DANGER

Improper installation, adjustment, alteration, service, or maintenance of a Combi, or installation of a damaged Combi can result in DEATH, INJURY, EQUIPMENT DAMAGE, and void the warranty.

NEVER install damaged Combis.

ALWAYS have qualified Cleveland Range authorized personnel install and service Combis.

5. Inspect the Combi for shipping damage.
 - a. Check carton and packing for shipping damage.
 - b. Note any damage on the shipping paperwork as soon as the carton arrives.
 - c. Unpack the Combi and check for shipping damage.
 - d. If the Combi is damaged or damage is suspected:
 - 1) Inform your dealer at once.
 - 2) Inform Cleveland Range in writing within 3 days.
 - 3) Submit a Damage Claim to the Shipper.

. INSTALLATION OF THE COMBI – General Instructions

General Instructions:

1. Select the Combi's operating location.
2. Complete the water, drain, and electric lines before positioning and leveling the Combi.
3. Position and level the Combi.
4. Connect the utility lines after positioning and leveling the Combi.
5. Call Cleveland Range at 216-481-4900 for the Free Start-Up Program's Performance Checkout.
6. After Setup and Performance Checkout, the Combi should provide years of reliable operation.

DANGER

**Improper lifting can result in DEATH, INJURY, AND EQUIPMENT DAMAGE.
Use enough workers with training and experience lifting heavy equipment to place
Combis on supporting surfaces, and lift and handle Combis and accessories.**

DANGER

**Operating an out of level Combi can cause DEATH, INJURY, and EQUIPMENT DAMAGE.
Combis must be level both front-to-back and side-to-side in all installations.
NEVER operate an out of level Combi.
If a Combi is suspected to be out of level, shut it down at once and call you qualified
Cleveland Range authorized service agency at once.**

WARNING

All clearance requirements above, below, and around the Combi are the same for non-combustible locations as for combustible locations.
Failure to maintain required clearances and additional distances as needed can result INJURY and EQUIPMENT DAMAGE.
Consult manufacturers' literature, and sales and service agencies as needed.

C. SPECIAL INSTRUCTIONS FOR CASTER EQUIPPED COMBI STANDS AND COMBIS

1. Read all instructions before beginning installation.
2. Level the floor if needed.
3. **NOTE:** Combis on caster-equipped stands have less adjustment for level than adjustable foot equipped stands.
4. The front wheels of caster-equipped stands and Combis have locks. Check the caster locks for function and position before installation.
5. Follow the separate instructions included with the Stand, Stacking Kit, or Caster Kit.
6. Make sure the Stand, Stacking Kit, or Caster Kit matches the Combi(s).
7. Use only genuine Cleveland Range Stands, Stacking Kits, Caster Kits, and replacement parts.
8. Use of Stands, Stacking Kits, Caster Kits, and replacement parts other than genuine Cleveland Range Stands, Stacking Kits, and Caster Kits and replacement parts can result in injury and / or catastrophic equipment failure, and voids the Warranty.
9. The appliance must be secured to building structure, to prevent any strain on the utility connections, and to help reduce the risk of electric shock.
10. The strain relief (restraining device) must be installed to limit the movement of the appliance without depending on the connector and the quick-disconnect device or its associated piping (gas, water, or electric). See separate instructions for attachment location and other details.
11. Connect the strain relief (restraining device) BEFORE starting the Combi
12. If the strain relief (restraining device) must be disconnected, it must be reconnected after the Combi has been returned to its originally installed position BEFORE restarting the Combi.
13. Prepare the installation location as described in the Combi Installation Manual.
14. For GAS (OGB, OGS) Combis: The installation of the gas supply shall be made with a connector that complies with the Standard for *Connectors for Movable Gas Appliances*, ANSI Z21.69 / CSA 6.16, and a quick disconnect device that complies with the Standard for *Quick Disconnect Devices for Use With Gas Fuel*, ANSI Z21.41 / CSA 6.9.
15. The appliance shall be installed using flexible conduit.
16. Mechanically secure the flexible conduit to the Combi's electrical access hole.



COMBI OVEN-STEAMER



Featuring the
"Advanced Closed System +3"

GAS Fired – with Steam Generator**Cooking Modes:**

- Hot Air
- Retherm
- "Delta T" slow cooking
- Steam
- "Cook & Hold"
- "Crisp & Tasty"
- Combi

Cleveland Standard Features:

- "Advanced closed system" with "Crisp & Tasty" de-moisturizing feature
- High efficiency, power burner heating system for hot air and steam generator saves energy and provides fast heat up times
- Fully insulated steam generator and cooking compartment for maximum energy savings
- Polished cooking compartment with coved corners for easy cleaning
- Six (6) 26" x 20" wire shelves
- Hinged fan guard and hinged removable pan racks
- Two (2) speed auto reversing convection fan for even heat distribution
- Space saving, easy to close "Disappearing Door"
- Door latch with safety vent position and wear-free door switch
- Vented, double glass door with integrated door stop
- Trolley with self draining condensate drip pan
- Easy to change, press-fit door seal
- Oven light with shock resistant safety glass
- Multipoint core temperature probe
- Easy to use electronic controls for all operational functions
- Self diagnostic system with full text message display
- Easy to understand menu icons with bright graphics display
- User friendly selector dial
- Exclusive "Smart Key" for selecting option settings
- Digital controls for temperature, time and core probe settings
- Eight (8) "Press & Go" one step, recipe start buttons
- Cook book library for up to 250 stored recipe programs, each recipe capable of 20 steps
- RS 232 connection for controlling one unit with a PC (personal computer)
- Memory module automatically saves unit settings and recipes
- Manual program override feature for operational settings
- Smooth action hand shower for compartment cleaning

Gas Fired Steam Generator

- Quiet, high efficiency, power burner heating system
- Built-in automatic rinse system
- Automatic fill and water level control
- Automatic generator drain

MODEL: OGB-20.20

CAPACITY: Twenty (20) – 18" by 26" full size sheet pans or
Forty (40) – 12" by 20" by 2 1/2" steam table pans

ITEM NUMBER _____

JOB NAME / NUMBER _____

**Short Form Specifications**

Shall be Cleveland Model: OGB-20.20 Combination Convection Oven / Steamer with simple to operate electronic programmable controls for Hot Air, Convection Steam, and Combination cooking modes, "Cook & Hold" and "Delta T" slow-cooking capabilities, "Advanced Closed System" with "Crisp & Tasty" de-moisturizing feature. Multiple cooking stage programs, stored recipe library, multipoint core temperature probe, "Press & Go", one-step recipe start buttons, "Smart Key" for selecting option settings, Two (2) speed auto reversing convection fan. Quiet, high efficiency power burner heating system; steam generator with automatic drain. "Disappearing Door". Capacity for twenty (20) 18" x 26" full size sheet pans, or forty (40) 12" x 20" x 2 1/2" pans.

Options and Accessories

- ConvoClean automatic compartment washing system
- PC-HACCP software for establishing "HACCP controls" and automatic documentation of the cooking process
- Universal pan-rack system to hold full size sheet pans without the use of wire shelves
- Lockable cover over operating controls for prison installations
- USB or RS 485 connection for networking and controlling up to 32 units with a personal computer
- Propane gas option
- Flue diverter
- Pan rack with trolley
- Plate rack with trolley for banquet operations
- Thermal cover for plate or pan rack
- ConvoClean compartment cleaning solution
- ConvoCare concentrate for compartment rinse cycle
- "Dissolve" generator descaling solution
- Chicken Grill Rack
- 12" x 20" Wire Baskets for frying products
- Additional 26" x 20" Wire Shelves
- Pre-heat bridge

SECT. IIC PAGE 27
0406

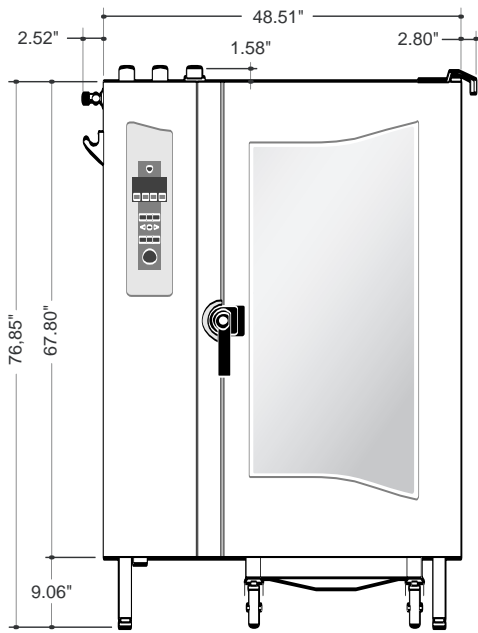

FRONT VIEW

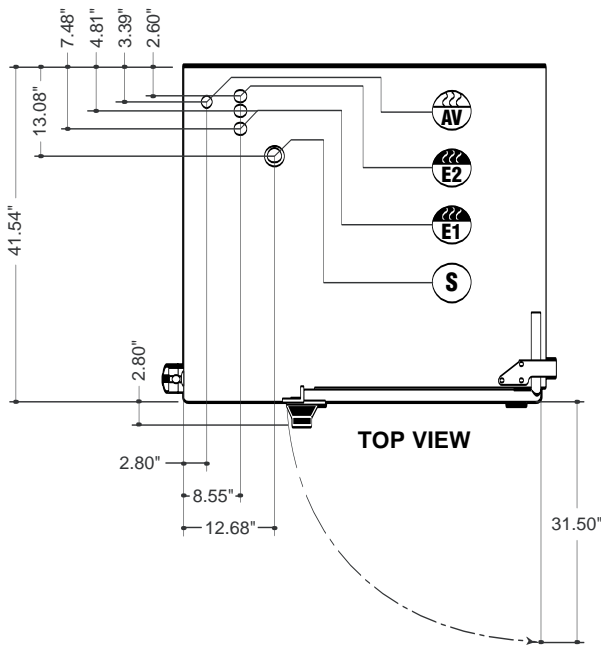

TOP VIEW

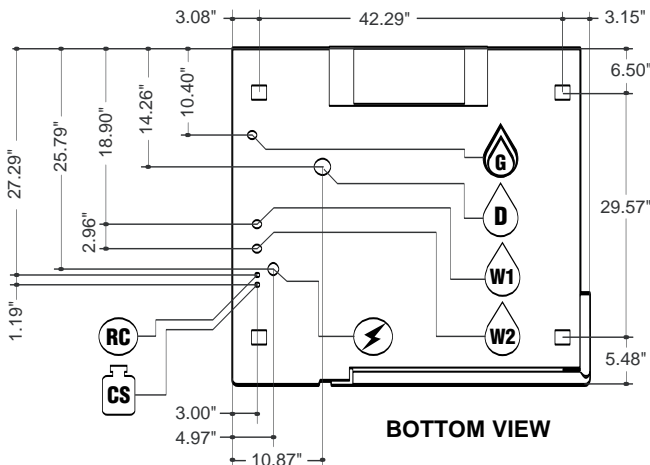

BOTTOM VIEW

NOTES:

Cleveland Range reserves right of design improvement or modification, as warranted.
 Many regional, state and local codes exist and it is the responsibility of the owner and installer to comply with the codes.
 Cleveland Range equipment is built to comply with applicable standards for manufacturers.

The "Advanced Closed System" offers the following advantages:

- Saves energy
- Automatic moisture level adjustment
- Low heat and steam emission to the kitchen
- Automatically regulated steam injection
- Enables immediate change into the steam mode
- "Crisp & Tasty" demisterizing function

Model: OGB-20.20

Pan Capacity [Unit (trolley) has 20 slide rails at 2.64" (67mm) apart]:

- 20 (20" x 26") full size wire racks
- 20 (18" x 26") full size sheet pans - **on wire racks**
- 40 (13" x 18") half size sheet pans - **on wire racks**
- 40 (12" x 20" x 2 1/2") steam table pans
- 40 (12" x 20" x 1") steam table pans
- 40 (12" x 20") frying baskets - (**no wire racks needed**)

For Banquet Operations: Optional Plate Rack holds 122 plates

Unit Dimensions: Width - 53.83", Depth - 44.34", Height - 78.43"

Shipping Dimensions: Width - 60", Depth - 50", Height - 86"
 (including packaging)

Shipping Weight: 970 Lbs (including trolley)

Required Clearances: Rear - 2", Left Side - 4", Right Side - 2 1/2"

- Allow for sufficient distance if a "high heat source" (i.e. Broiler) is located next to the unit.
- Allow for sufficient clearance on left side for service access (contact the factory service department for recommendations).
- Installation must comply with all local fire and health codes.

Agency Approvals: UL - Gas, UL - Sanitation (NSF Standards)



Electrical Requirements: 120 volt, 22.5 amps, 60 Hz, single phase
 Do not connect to a G.F.I. outlet



Gas Connection: 3/4" NPT
Gas Type: Natural Gas (Propane optional)
Gas Flow Pressure: Natural Gas - Min. 5.5" WC / Max. 14" WC
 Propane Gas - Min. 11" WC / Max. 14" WC
Total Connected Load: 265,500 BTU (239,000 BTU Propane)
Steam Generator: 132,700 BTU (119,000 BTU Propane)
Hot Air: 265,500 BTU (239,000 BTU Propane)

Water Connections: Cold Water (drinking water quality)
Flow Pressure: 30 - 60 PSI
Water Inlets: 3/4" GHT-F (Female Garden Hose Connection)



Treated Water for Steam Generator



Untreated Water for Condenser and Hand Shower



Drain Connection: 2" Tube

Venting: Exhaust Hood required



Gas Exhaust for Hot Air Heating



Gas Exhaust for Steam Generator



Air Vent



*Connection for Cleaning Solution



*Connection for Rinse Cycle



Low Pressure Safety Valve

*Available as an option



COMBI OVEN-STEAMER



Featuring the
"Advanced Closed System +3"

GAS Fired – Boilerless**Cooking Modes:**

- Hot Air
- Retherm
- "Delta T" slow cooking
- Steam
- "Cook & Hold"
- "Crisp & Tasty"
- Combi

Cleveland Standard Features:

- "Advanced closed system" with "Crisp & Tasty" de-moisturizing feature
- High efficiency, power burner heating system
- Fully insulated cooking compartment for maximum energy savings
- Polished cooking compartment with coved corners for easy cleaning
- Six (6) 26" x 20" wire shelves
- Hinged fan guard and hinged removable pan racks
- Two (2) speed auto reversing convection fan for even heat distribution
- Space saving, easy to close "**Disappearing Door**"
- Door latch with safety vent position and wear-free door switch
- Vented, double glass door with integrated door stop
- Trolley with self draining condensate drip pan
- Easy to change, press-fit door seal
- Oven light with shock resistant safety glass
- Multipoint core temperature probe
- Easy to use electronic controls for all operational functions
- Self diagnostic system with full text message display
- Easy to understand menu icons with bright graphics display
- User friendly selector dial
- Exclusive "**Smart Key**" for selecting option settings
- Digital controls for temperature, time and core probe settings
- Eight (8) "**Press & Go**" one step, recipe start buttons
- Cook book library for up to 250 stored recipe programs, each recipe capable of 20 steps
- RS 232 connection for controlling one unit with a PC (personal computer)
- Memory module automatically saves unit settings and recipes
- Manual program override feature for operational settings
- Smooth action hand shower for compartment cleaning
- Injection system for steam

Options and Accessories

- ConvoClean automatic compartment washing system
- PC-HACCP software for establishing "HACCP controls" and automatic documentation of the cooking process
- Universal pan-rack system to hold full size sheet pans without the use of wire shelves
- Lockable cover over operating controls for prison installations

MODEL: OGS-20.20

CAPACITY: Twenty (20) – 18" by 26" full size sheet pans or
Forty (40) – 12" by 20" by 2 1/2" steam table pans

ITEM NUMBER _____

JOB NAME / NUMBER _____

**Short Form Specifications**

Shall be Cleveland Model: OGS-20.20 Combination Convection Oven / Steamer with simple to operate electronic programmable controls for Hot Air, Convection Steam, and Combination cooking modes, "**Cook & Hold**" and "**Delta T**" slow-cooking capabilities, "**Advanced Closed System**" with "**Crisp & Tasty**" de-moisturizing feature. Multiple cooking stage programs, stored recipe library, multipoint core temperature probe, "**Press & Go**", one-step recipe start buttons, "**Smart Key**" for selecting option settings, two (2) speed auto reversing convection fan. Quiet, high efficiency power burner heating system; boilerless. "**Disappearing Door**". Capacity for twenty (20) 18" x 26" full size sheet pans, or forty (40) 12" x 20" x 2 1/2" pans.

- USB or RS 485 connection for networking and controlling up to 32 units with a personal computer
- Propane gas option
- Flue diverter
- Pan rack with trolley
- Plate rack with trolley for banquet operations
- Thermal cover for plate or pan rack
- ConvoClean compartment cleaning solution
- ConvoCare concentrate for compartment rinse cycle
- "Dissolve" generator descaling solution
- Chicken Grill Rack
- 12" x 20" Wire Baskets for frying products
- Additional 26" x 20" Wire Shelves
- Pre-heat bridge

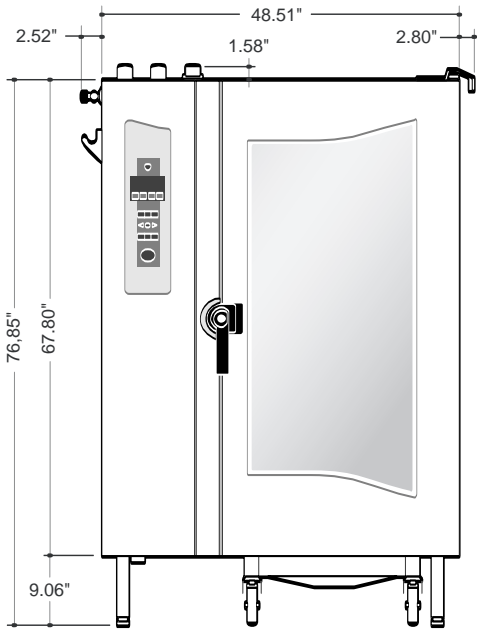

FRONT VIEW

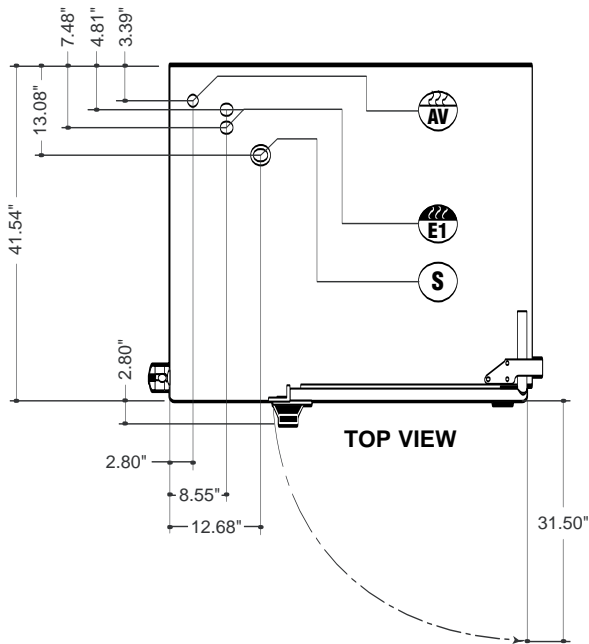

TOP VIEW

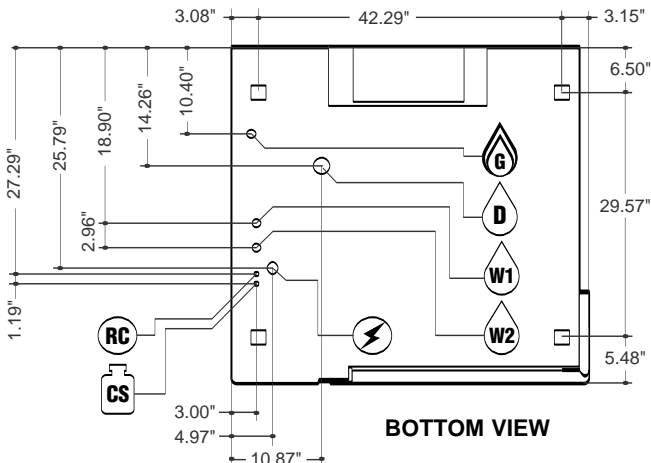

BOTTOM VIEW

NOTES:

Cleveland Range reserves right of design improvement or modification, as warranted.
 Many regional, state and local codes exist and it is the responsibility of the owner and installer to comply with the codes.
 Cleveland Range equipment is built to comply with applicable standards for manufacturers.

The "Advanced Closed System" offers the following advantages:

- Saves energy
- Automatic moisture level adjustment
- Low heat and steam emission to the kitchen
- Automatically regulated steam injection
- Enables immediate change into the steam mode
- "Crisp & Tasty" demisterizing function

Model: OGS-20.20

Pan Capacity [Unit (trolley) has 20 slide rails at 2.64" (67mm) apart]:

- 20 (20" x 26") full size wire racks
- 20 (18" x 26") full size sheet pans - **on wire racks**
- 40 (13" x 18") half size sheet pans - **on wire racks**
- 40 (12" x 20" x 2 1/2") steam table pans
- 40 (12" x 20" x 1") steam table pans
- 40 (12" x 20") frying baskets - (**no wire racks needed**)

For Banquet Operations: Optional Plate Rack holds 122 plates

Unit Dimensions: Width - 53.83", Depth - 44.34", Height - 78.43"

Shipping Dimensions: Width - 60", Depth - 50", Height - 86"
 (including packaging)

Shipping Weight: 970 Lbs (including trolley)

Required Clearances: Rear - 2", Left Side - 4", Right Side - 2 1/2"

- Allow for sufficient distance if a "high heat source" (i.e. Broiler) is located next to the unit.
- Allow for sufficient clearance on left side for service access (contact the factory service department for recommendations).
- Installation must comply with all local fire and health codes.

Agency Approvals: UL - Gas, UL - Sanitation (NSF Standards)



Electrical Requirements: 120 volt, 22.5 amps, 60 Hz, single phase
 Do not connect to a G.F.I. outlet



Gas Connection: 3/4" NPT
Gas Type: Natural Gas (Propane optional)
Gas Flow Pressure: Natural Gas - Min. 5.5" WC / Max. 14" WC
 Propane Gas - Min. 11" WC / Max. 14" WC
Total Connected Load: 265,500 BTU (239,000 BTU Propane)
Hot Air: 265,500 BTU (239,000 BTU Propane)

Water Connections: Cold Water (drinking water quality)
Flow Pressure: 30 - 60 PSI
Water Inlets: 3/4" GHT-F (Female Garden Hose Connection)



Treated Water for Steam Production



Untreated Water for Condenser and Hand Shower



Drain Connection: 2" Tube

Venting: Exhaust Hood required



Gas Exhaust for Hot Air Heating



Air Vent



*Connection for Cleaning Solution



*Connection for Rinse Cycle



Low Pressure Safety Valve

*Available as an option

CONTROL PANEL BASIC OPERATION

A. QUICK START GUIDE

ALWAYS PRE-HEAT THE OVEN CHAMBER!

1. Switch on with key (1).
2. Select cooking mode with keys (2-5).
3. Press key (6) to start.

OR

1. Press key (18) and rotate Selector Dial (23) to set oven temperature.
2. Press key (19) and rotate Selector Dial (23) to set cooking time.

OR

1. Press key (20) and rotate Selector Dial (23) to set core temperature.

ALL

1. Press key (6) to start the Combi.
2. To change the settings while cooking: press keys (18) OR (19) OR (20) and adjust the settings with the Selector Dial (23).
3. When the buzzer sounds press key (6) or open the door.

NOTES: See “CONTROL PANEL DETAIL VIEW” in Chapter 4, Section B for detailed descriptions of control panel functions.



**Figure 4-1a
Control Panel**

B. CONTROL PANEL DETAIL VIEW

Note: Item numbers correspond to numbers on the control panels in Figure 4-1b

1. ON/OFF

When the Combi is turned ON:

- Self-diagnosis is performed.
- Oven light turns on.
- Steam generator fills and heats (OEB and OGB models).

Cooking Modes

2. Steam

- Oven temperature is continuously variable between 86°F and 248°F.

3. Combi Hot Air and Steam

- Oven temperature is continuously variable between 212°F and 482°F.

4. Hot Air

- Oven temperature is continuously variable between 86°F and 482°F.

5. Retherm

- Oven temperature is continuously variable between 248°F and 320°F.

6. Start/Stop

- Start cooking modes and recipes.
- Stop the cooking activity.
- Escape or Exit Smart Key functions

Programming / Help

7. Cookbook

- Call up, exit cookbook.
- View a list of stored recipes in the display.

8. Smart Key

- Set Extra Functions.
- Set-Up the Combi.
- Enter Sub-Menus.

9. Edit

- Create, change, copy, and delete recipes.

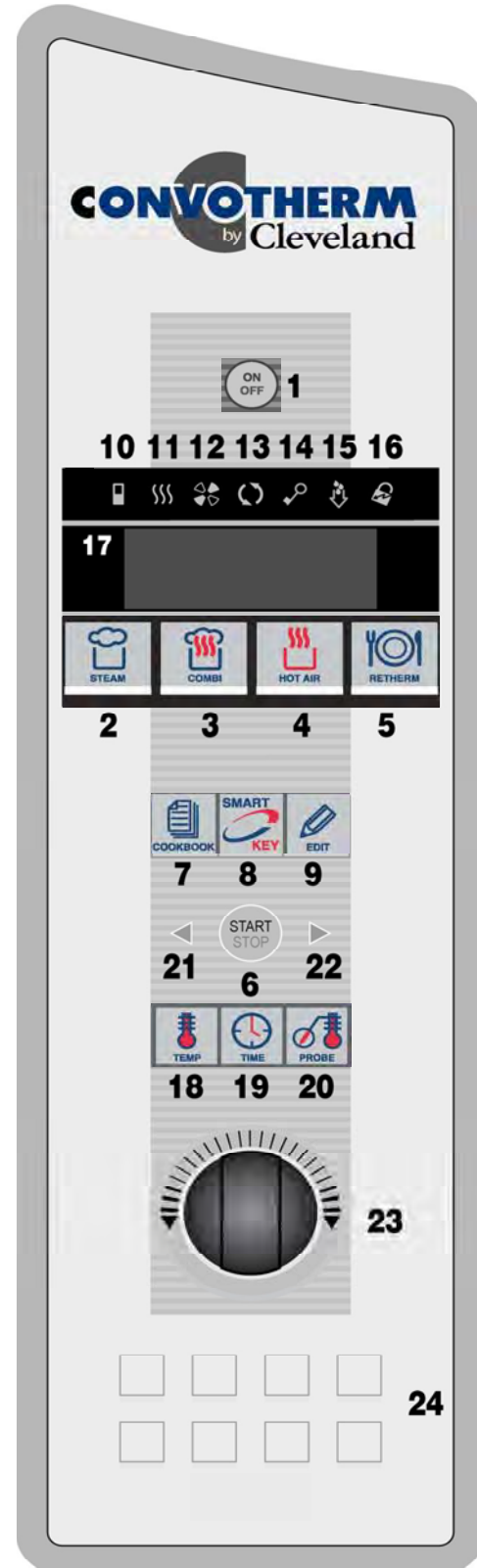

Figure 4-1b
Control Panel

Function Indicators

- Light up when function or activity is engaged:

10. Reduced Power

11. Burner or Electric Heating ON

12. Reduced Fan Speed

13. Cooking Mode Engaged

14. Button Lock

15. Crisp & Tasty Engaged

16. Program Protection

17. Display

- **Display in normal mode:**
 - Date.
 - Time.
 - Oven Temperature.
 - Cooking Time
 - Core Probe Temperature.
- **Display in programming mode:**
 - Clear text.
 - Memory.
 - Symbols.

Settings

18. Oven Temperature

- Set the nominal oven temperature.
- View the actual or nominal oven temperature.

19. Cooking Time

- Set the cooking time from 1 minute to 9 hours, 59 minutes using the Selector Dial.
- Set Continuous Mode
 1. At 9:59 or 0:01, release the Selector Dial.
 2. Turn the Selector Dial again to the left or right.
- See the actual or nominal cooking time.
- See elapsed cooking time when using Core Temperature mode.

20. Core Temperature

- Set the nominal core temperature.
- See the actual or nominal core temperature.
- See the actual core temperature during cooking time mode.

21 & 22. Scroll Left and Scroll Right

- Page / Scroll one step forward or back in programming mode.

23. Selector Dial

- Set: Oven temperature, cooking time, core temperature, recipe name, recipe number.
- Select Smart Key functions, editing functions and recipes in the cookbook.

24. Press & Go Keys

- Start saved recipes with one key.
- LED below key lights up when corresponding recipe is started.

Notes:

- **Magnetic door switch**

If the oven door is opened during operation, the magnetic door switch automatically interrupts the recipe. The timer stops. After closing the oven door, the Combi automatically continues the recipe. If the oven door is opened when the buzzer sounds at the end of a recipe, it automatically switches off.
- Operate controls with hands only!

AT THE END OF THE DAY OR SHIFT

A. Cleaning the Oven Chamber

 CAUTION
Clean the oven chamber at least once per day or more frequently as needed Failure to clean the Combi properly and regularly can cause equipment damage. Damage caused by improper cleaning will invalidate the Warranty!

1. Cleaning – General

- a. Regular cleaning of the Combi after use, inside and out, helps guarantee many years of satisfaction from your Combi.
- b. Clean and maintain the Combi ONLY when the Combi is cold.
- c. Use the hand shower only inside the oven chamber.
- d. Clean the outside the Combi by hand.
- e. Never use the hand shower, hose, pressure washer or similar device on the outside of the Combi.
- f. NEVER spray anything on or into the air intakes or outlets of the Combi.
- g. Do NOT use hoses, pressure washers, high-pressure cleaners, or water jets to clean inside the Combi oven chamber.
- h. Do NOT spray water into a hot oven chamber.
- i. Use only genuine Convotherm by Cleveland and Cleveland Range cleaning and descaling products. Follow the instructions and heed and obey the warnings on the labels. Other products can cause injury, present health hazards, and damage the Combi.
- j. Never use irritant, acidic, highly alkaline cleaners, high-alcohol, chlorine, chlorinated, or abrasive cleaning agents, scrapers, or abrasive materials to clean the Combi.
- k. Poor water quality can cause discoloration inside the oven chamber. Remove these discolorations with CONVOCare. Spray CONVOCare on the affected surfaces in a COLD oven chamber, wait 10 minutes, wipe off with a soft cloth or sponge, and begin cleaning as usual.
- l. Damage caused as a result of improper cleaning voids the warranty.

2. Semi-Automatic and Automatic Cleaning - General

- a. If the oven chamber is very heavily soiled, additional manual cleaning may be necessary.
- b. Depending on the level of soiling of the oven chamber, the engaging frames and grills may be left in the oven during the automatic cleaning process.
- c. Do NOT interrupt the semi-automatic or automatic cleaning process.

 **WARNING**

When working with cleaning agents, nozzle rinsing fluid and spray bottles: Wear suitable clothing, protective gloves and protective goggles to help protect from splashes and spills. Failure to do so can result in chemical burns on skin and in eyes.

 **WARNING**

Read, understand, and heed and obey all instructions and safety information found on cleaning agent labels, Material Safety Data Sheets, and related documents and sources. Failure to do so can result in death, injury, and equipment damage.

3. Manual Cleaning of the Oven Chamber

- a. Clean the Combi daily to prevent discoloration and corrosion of the stainless steel.
 - 1) Avoid scratching the oven chamber or engaging frame.**
 - 2) Scratches can collect soil and / or allow corrosion to begin.
 - 3) Do NOT use harsh or abrasive cleaning agents, scouring pads, or scrapers.
- b. Clean the fan guard and the fan area behind the fan guard at the same time.
 - 1) Release the quick-action locks on the oven racks and fan guard.
 - 2) Pivot the oven racks and fan guard out into the oven chamber.
 - 3) After cleaning, push the oven racks and fan guard closed and fix them in place with the quick-action locks.

 **CAUTION**

Do NOT use U-Shaped racks that are bent or otherwise damaged in any way. Pans and accessories placed in damaged racks can tip and spill, causing burns, injuries and/or equipment damage

- 4) Make sure that the U-Shaped racks do not become bent; otherwise grills, racks, containers and accessories will no longer be safely supported. If U-Shaped racks become bent then remove the Combi from service and contact your qualified Cleveland Range authorized service representative at once.
- c. Clean the interior of the of the double glass doors daily.
 - 1) Release the quick-action locks on the door glass.
 - 2) Clean the glass with a non-abrasive cleaner and a soft cloth.
 - 3) Do not use harsh or abrasive cleaning agents, scouring pads, or scrapers because they will damage the glass.
- d. Regular cleaning of the hygienic plug-in gasket (door gasket) increases service life.
 - 1) Wait for the gasket to cool.
 - 2) Clean the gasket with mild, scent free dish detergent and a soft cloth.
 - 3) Do not use harsh or abrasive agents, scouring pads or scrapers because they will damage the gasket.
 - 4) Air dry the gasket.

- e. Clean the Bypass Measuring Aperture. (Opening in the oven chamber on the left-hand side, slightly below the door latch. See diagram.)

- 1) Spray with CONVOClean.
- 2) Rinse clean with the hand shower.

- f. Remove and clean the drain cover.

- 1) Clean food residue and drippings from the tray and drain in the oven chamber.
- 2) Spray on original CONVOClean oven chamber cleaner and allow it to take effect.
- 3) Rinse thoroughly with the hand shower.

- g. Clean the drain and make sure that it is not blocked.

- h. Clean the demoinsturizing tray (trough shaped area under the drain cover).

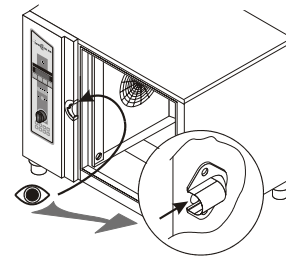

Bypass



Drain Cover and Drain

- i. Clean the door drip tray, appliance drip trays and accessory drip trays.

NOTES:

- If a white deposit forms inside the oven chamber, the water treatment system is not correctly set, or the addition of a water treatment system is required. To remove this deposit, use vinegar and a soft cloth.
- Ask your qualified Cleveland Range authorized service representative about adding or setting a water treatment system.



B. Semi-Automatic Cleaning of the Oven Chamber

NOTE: Do NOT press the Start/Stop key while using the Semi-automatic Cleaning process. This stops the cleaning process.

WARNING

The Semi-Automatic Cleaning process is designed to be started when the oven chamber temperature is at or below 158°F. Death, injury, and equipment damage can result from starting the Semi-Automatic Cleaning process when the oven chamber is above 158°F.

1. Before starting the Semi-Automatic Cleaning process, make sure the oven chamber is below 158°F by stopping all processes and pressing the Temperature key twice to view the actual temperature.
 - a. If the oven chamber is above 158°F then open the Combi door and wait 15 minutes.
 - b. Check the oven temperature again.
 - 1) If the oven temperature is at or below 158°F then go to Step 2.
 - 2) If the oven temperature is still above 158°F then wait 15 more minutes and check the oven chamber temperature. Repeat this step as needed until the oven chamber temperature is at or below 158°F and then go to Step 2.
2. See separate instruction sheet P/N 260AYM, "One-Hand Sprayer with Telescoping Wand," for safety information, detailed instructions for using the sprayer, P/N 111598, and other information.
3. Always wear appropriate protective clothing and equipment when using this Sprayer, including protective gloves and goggles.
4. Close and latch the Combi door.
5. If the Combi is OFF, turn it ON.
6. Press the Smart Key. Various options appear in the display.
7. Use the Selector Dial to select "Cleaning" .
8. Confirm by pressing the Smart Key.
9. Confirm "Yes" with the Smart Key. The semi-automatic cleaning process starts.
10. Semi-automatic cleaning uses cooking modes to assist the cleaning process. The display shows the nominal values for the cooking modes.
 - a. The first step is Hot Air mode at 158°F for 10 minutes, followed by a Signal Tone.
11. After the first Signal Tone, open the oven door, and follow instruction sheet in P/N 260AYM to spray the oven chamber, drain, grills, plates etc. with original Convotherm by Cleveland CONVOClean.
12. Close and latch the Combi door and allow the CONVOClean to take effect. The Semi-Automatic Cleaning mode continues to run.
 - a. The second step is Steam mode at 86°F for 10 minutes, followed by a Signal Tone.
13. After the second Signal Tone, clean behind the fan guard and the fan area.
 - a. Release the quick-action locks on the oven racks and fan guard.
 - b. Swing the oven racks and fan guard into the oven chamber.
 - c. After cleaning, swing the oven racks and fan guard closed and fix it in place with the quick-action locks.
14. Close and latch the Combi door. The Semi-Automatic Cleaning mode continues automatically.

- a. The third step is Steam mode at 86°F for 1 minute. No action is needed.
 - b. The fourth step is Steam at 212°F for 10 minutes, followed by a Signal Tone.
15. Turn OFF the Combi when the Signal Tone sounds.
 16. Use the hand shower to rinse thoroughly the oven chamber, accessories, and behind the fan guard.
 17. In the case of severe staining or soiling, repeat the cleaning process.
 18. After use or after cleaning, leave the Combi door open.



C. CONVOClean Automatic Cleaning System (optional):

NOTES:

- Do NOT interrupt the automatic cleaning process. Interrupting and restarting the Automatic Cleaning System with the ON/OFF key may start a 6 minute forced rinsing of the oven chamber to remove any CONVOClean and CONVOCare residue when the ON/OFF key is turned back ON. The Signal Tone sounds at the end of the forced rinsing cycle and the Combi is ON.
- Do not open the Combi door during the automatic cleaning process, unless the instruction “Open the door” and “close the door,” appears in the display.
- Pre-clean manually to save water and CONVOClean by selecting a lower cleaning setting.
- If the security questions are not answered within 5 seconds, the Combi resets itself to the query level and will not start.
- If the message “No cleaner pressure” appears, check that there is enough CONVOClean and/or CONVOCare in the correct containers. Refill them if necessary (red hose for CONVOClean, and blue or white hose for CONVOCare).

CAUTION

Always make sure the cleaning agent containers are correctly connected to the Combi

CONVOClean => RED

CONVOCare => BLUE or WHITE

- A. See P/N 260AZA, “Instructions for CONVOClean System Start-up Kit,” for hose attachment, solution mixing, and other information.
- B. The CONVOClean Automatic Cleaning Process
1. The oven chamber **must be cold** before starting this process. If the oven chamber is still hot, the error message, “oven temp too hi / please wait” appears in the display. If this error message appears, open the Combi door, wait 15 minutes and then try to start the automatic cleaning process. Repeat as needed.
 2. Before starting, remove large pieces food or cooking residue from the oven chamber to help prevent the drain from becoming blocked.
 3. Check the level of Convotherm by Cleveland CONVOClean and CONVOCare.
 - a. The containers **must** be full.
 - b. The suction pipes **must** be located in the fluid.
 - c. The hoses must be properly attached to the Combi.
 4. Press the Smart Key. Various options appear in the display.
 5. Use the Selector Dial to select “CONVOClean system” .
 6. Confirm by pressing the Smart Key.
 7. PRESS the Temperature key and select the cleaning level (1-4) with the Selector Dial. Approximate run times are listed to help plan use of the CONVOClean system. Times may vary by +/- 15 minutes.

1	“Light Soiling”	55	minutes.
2	“Medium Soiling”		1 hour and 30 minutes.

- 3 "Strong Soiling" 2 hours.
- 4 'Strong Soiling – Shining+' 2 hours and 45 minutes.

8. Press the Smart Key.
9. "Food inside oven?" appears in the display.
10. If the oven is empty, then answer "No."
11. Confirm by pressing the Smart Key.
12. "Start auto-cleaning?" appears in the display.
13. Answer "Yes."
14. Confirm by pressing the Smart Key.
15. The CONVOClean system starts.
16. The instruction "open the door" appears in the display to check the function of the magnetic door switch.
17. Open the Combi door.
18. The instruction "close the door," appears in the display to check the function of the magnetic door switch.
19. Close the door.
20. The self test "water supply open?" appears in the display. If the water supply is on (open), then the self test question disappears from the display.
 - a. If "water supply open?" does not disappear from the display, or "not enough water" appears in the display, then check the water supply.
 - b. The CONVOClean system resumes running after the water supply is restored.
21. "Cleaning in progress" appears in the display and the CONVOClean process runs.
22. The Signal Tone sounds at the end of the CONVOClean cycle and "end of cleaning" appears in the display.
23. Press the Start/Stop key to stop the Signal Tone and end the CONVOClean process.
24. The Combi is ON and ready to use.
25. After use or after cleaning, leave the Combi door open.

DESCALE STEAM GENERATOR

A. GENERAL INFORMATION

1. Steam generators should be descaled at least once a month, depending on scale buildup. If you have serious steam generator scale buildup, a water treatment system should be installed for the steamer. If this is not possible, the frequency of descaling should be increased.
2. Cleveland Range, recommends the use of ***DISSOLVE*[®] Descaler Solution, Cleveland Range Part Number 106174**. No other system of steamer descaling should be used.
3. **NOTE:** Part No. 106174 is the Part No. for a case (6 1-gallon containers) of *DISSOLVE*[®] descaler.
4. THESE INSTRUCTIONS ARE FOR USE WITH *DISSOLVE*[®] DESCALER SOLUTION Cleveland Range Part Number 106174 ONLY.
5. **Health Hazard Data, Effects of Overexposure** – This product may cause a burning sensation to eyes or skin.
6. **Emergency and First Aid Procedures** - In case of eye contact, immediately flush eyes with plenty of water. If irritation persists, seek medical attention. In case of skin contact: wash with soap and water. If inhaled, remove to fresh air. If burning persists, call a physician. If swallowed, drink 1 or 2 glasses of water and call a physician.
7. **Spill or Leak Procedures** – Rinse with plenty of water to dilute. Sodium carbonate or calcium carbonate may be used to soak up liquid. Spent material is considered non-hazardous and may be disposed of in a sewer system with water flush.

WARNING

The liquid solution in Cleveland Range Descaler Solution Part No. 106174, “*DISSOLVE*[®] Descaler Solution,” can be harmful if not handled properly.

Follow these basic safety rules for handling and using this product to help prevent death or injury:

- Wear protective clothing when mixing or applying chemical cleaners.
- Wear rubber gloves, and OSHA approved eye protection when descaling to help avoid injury.
- Avoid breathing fumes. If liquid comes in contact with skin, wash with soap and water.
- If chemical contacts eyes, flush with water. If irritation persists, seek medical attention
- If chemical is swallowed or ingested, drink 1 or 2 glasses of water and call a physician.

Failure to do so can result in death or injury.

CAUTION

Use ONLY the *DISSOLVE*[®] Descaler method using Part No. 106174 to descale the Combi.

Read, understand, and follow both the descaling procedure instructions and warnings, and the instructions and warnings on the *DISSOLVE*[®] label and MSDS.

Injury, equipment damage, and property damage can result from using other descaling systems and/or failing to follow the descaling procedure and *DISSOLVE*[®] instructions and warnings.

! DANGER

**Do NOT heat the Combi during descaling.
Death, injury, equipment and property damage can result.**

! WARNING

This procedure is slightly different depending on the model being descaled. This entire procedure should be read and fully understand as it applies to the model being descaled, before beginning the actual descaling operation.

B. GENERAL SAFETY FOR DESCALING

1. Always wear suitable protective clothing including appropriate gloves, and eye protection.
2. Read, understand, heed and obey and obey and obey, and follow all directions on the descaler label, MSDS, and related documents
3. Never operate the Combi when descaler has been applied or while descaling.
4. Descale only when the Combi is cold.
5. Immediately wipe up any leaked or spilled descaling fluid.

C. COMBI ATMOSPHERIC STEAM GENERATOR DESCALING PROCEDURE

(For *DISSOLVE*® Descaler Solution Part No. 106174)

This procedure takes approximately 3 hours to complete.

Do NOT heat the Combi during descaling.

1. Turn ON the Combi at the Control Power Service Disconnect switch located below the hand shower.
 2. Turn ON the Combi with the ON/OFF key.
 3. Open the door to the cooking compartment.
 4. Run a manual steam generator rinse cycle.
To Empty and Rinse the Steam Generator:
 - a. Press the Smart Key.
 - b. Select “Manual Steam Generator Rinse” with the Selector Dial.
 - c. Confirm “Yes” with the Smart Key.
 - d. Steam generator rinses and begins to refill to operating level.
 4. Remove the cap from the descale port located at the top of the Combi (See Figure 6-1).
 5. **While the steam generator is filling with water, use a funnel (NOT INCLUDED) to add 3/4 gallon of *DISSOLVE*® descaler solution into the descaling port of 20.20 Combis, and 1/2 gallon for all other models**



**Figure 6-1
Descaling Port
Located at Right Rear of the Combi**

- While adding liquid to the steam generator through the descaler inlets, pour slowly to avoid overflow.
 - Wipe up any spills at once to avoid etching.
6. After the automatic fill cycle has ended, turn OFF the Combi with the ON/OFF key, and at the Control Power Service Disconnect switch located below the hand shower. See Figure 6-2.
 7. Add cold tap water through the descale port until descaling solution enters the cooking compartment through the steam port or until the descaling port overflows (water required varies depending on the Model).
 - Wipe up any spills and overflows.
 8. Let the Descaler work for 1 hour.
 9. Turn the Combi ON at the Control Power Service Disconnect switch located below the hand shower. See Figure 6-2.
 10. Turn ON the Combi with the ON/OFF key.
 11. Run a manual steam generator rinse cycle (Step 4).
 12. After the automatic fill cycle has ended, turn OFF the Combi with ON/OFF key, and at the Control Power Service Disconnect switch located below the hand shower. See Figure 6-2.
 13. Add water through the descale port until water enters the cooking compartment through the steam port or until the descaling port overflows (water required varies depending on the Model) to rinse descaler from the area above the normal water fill level.
 14. Replace the descale port cap.
 15. Turn the Combi ON at the Control Power Service Disconnect switch located below the hand shower. See Figure 6-2.
 16. Turn ON the Combi with the ON/OFF key.
 17. After the Automatic Fill ends, run a manual steam generator rinse cycle (See Step 4).
 18. Run Combi mode for 30 minutes at 212° F with Crisp & Tasty function.
 19. Close the cooking compartment door.
 - a. Press Combi key.
 - b. Press Temperature key.
 - c. Set temperature with Selector Dial to 212° F.
 - d. Press Time key.
 - e. Set time with the Selector Dial for 30 minutes.
 - f. Press Smart Key Various options appear in the display.
 - g. Select “Crisp & Tasty” with the Selector Dial.
 - h. Select the Crisp & Tasty level to “high demoisturizing – continuous” with the Selector Dial.
 - i. Confirm “Yes” with Smart Key.
 - j. The Crisp & Tasty icon  appears in the display.
 - k. Press the Start/Stop key to start.
 - l. Signal Tone sounds and steaming stops after 30 minutes.
 - m. Press the Start/Stop key to end the Signal Tone.
 20. Run a manual steam generator rinse cycle. (See Step 4) This is the final rinse. The Combi is now ready for normal operation.

CLEVELAND RANGE OGB 20.20 SEQUENCE OF OPERATIONS

When using these instructions refer to the OGB 6.20 wiring schematic.

- 1 When 120 VAC is applied to the combi, it is sent to the Power Control Switch (S1).
- 2 When the Power Control Switch (S1) is closed
 - a The red light in the switch is energized.
 - b 120 VAC is sent through the line filter (Z1) then through the 20 amp fuse (F10.1) to terminal L1 on the Motor Drive (U10.1)
 - c 120 VAC is sent through the line filter (Z2) then through the 20 amp fuse (F10.2) to terminal L1 on the Motor Drive (U10.2)
 - d 120vac is sent through the 2 amp fuse (F1.1) to
 - To terminals 1 and 2 of connector X1 on the Upper Hot Air Power Burner Control (U20)
 - To terminals 1 and 2 of connector X1 on the Steam Power Burner Control (U21)
 - To terminals 1 and 2 of connector X1 on the Lower Hot Air Power Burner Control (U22)
 - The 12 VDC Power Supply (G1)
 - ◇ 12 VDC is sent to terminals 1 and 2 of connector X28 on the Gas Board (A20)
 - ◇ 12 VDC is sent to terminal 3 and 4 of connector X10 on the Control Board (A10)
 - To terminal 1 of connector X12 on the Control Board (A10)
 - e With 12 VAC to the Control Board (A10) The Operation Board (A11) is energized
 - An alarm will sound for one second
 - All the LED's and the display will energize one at a time.
 - "STARTING" will be displayed for 3 seconds
 - "Please wait" will be displayed
 - The international model number will be displayed
 - The time and date will be displayed and this will continue until the on/off switch is depressed.
- 3 When the ON/OFF is depressed with the combi in the steam mode
 - a After a date change (the first time the combi is turned on) the display will ask "Generator Flush?". If no answer is given in 10 seconds or a yes is indicated the flush will begin.
 - 120 VAC is sent from terminal 1 of connector X13 on the Control Board (A10) to the Generator Pump (M4).
 - As the water level drops below the probes the fill solenoid (Y3) will energize. This rocking of the water will help flush scale from the generator.

- If the condensate box is heated to 140 degrees F at the B3probe, 120 VAC is sent from terminal 5 of connector X12 to the condenser valve (Y1) until the temperature drops.
- b The display will show the set temperature and set time when the flush is done or a negative reply is made to the “Generator Flush?”.
- c The Control Board (A10) will check the water level by looking for a ground at terminals 1 and 2 on connector X15. These are connected to the high and low probes (B1) in the steam generator.
 - If the ground is not found 120 VAC is sent from terminal 7 on connector X12 on the Control Board (A10) to the fill solenoid (Y3)
 - The fill solenoid opens and the generator is filled until both probes are grounded.
 - ◊ If the top probe becomes ungrounded for more that 5 seconds the fill solenoid (Y3) will energize.
 - ◊ If the bottom probe becomes ungrounded the combi will fill immediately and the combi will not heat
- d When terminal 2 on connector X15 is grounded, the Control Board (A10) sends 120 VAC to
 - The primary of the Hot Air 24v Transformer (T1)
 - ◊ 24 VAC is sent from the secondary of the transformer to the Hot air Burner Control (N20)
 - The primary of the Steam 24v Transformer (T2)
 - ◊ 24 VAC is sent from the secondary of the transformer to the Steam Burner Control (N21)
 - Terminal 1 on connector X20 of the Gas Control Board (A20)
 - Terminal 12 on connector X1 of the Upper Hot Air Control Module (N20)
 - Terminal 12 on connector X1 of the Steam Control Module (N22)
 - Terminal 12 on connector X1 of the Lower Hot Air Control Module (N22)
- e If the Steam Generator temperature is less than 190 dgreees the Control board transmits and receives a signal from terminals 5,6,7 and 8 on connector X10 to terminals 3,4,5 and 6 of connector X28 on the Gas Board (A20)
 - The Gas Board (A20) begins the steam generator heat circuit
 - ◊ A signal is sent from terminal 8 of connector X24 to terminal 4 of connector X2 on the Steam Power Burner and Fan Control (U21) selecting the set speed of the combustion blower.
 - (a) When this speed is attained the signal is sent from terminal 2 of connector X2 on the Steam Power Burner and Fan Control (U21) to terminal 9 of connector X24 on the Gas Board (A20)
 - ◊ A request for heat is sent from terminal 3 of connector X21 on the Gas Board (A20) to terminal 10 on connector X1 on the Steam Burner Control Module (N21)
 - (a) 120 VAC is sent from terminal 8 of connector X1 of the Steam Burner Control Module through the high limit (B7.2) to terminal 7 of connector X1 of the Steam Burner Control Module

- (b) 24 VAC is sent from terminal 2 of connector X2 on the Steam Burner Control Module (N21) to the hot surface igniter (R20).
 - (c) The gas valve is energized allowing gas and air into the burner chamber to be ignited by the hot surface igniter.
 - (d) The Steam Burner Control Module (N21) senses between 0.5 and 4.0 micro-amps DC from the flame sensor (P1) at terminal 3 of connector X2 (within 4 seconds) and sends a signal from terminal 2 of connector X1 to terminal 11 of connector X25 on the Gas Board (A20)
 - The steam generator heat circuit continues until 190 degrees F is detected from the Steam Generator probe (B4) at terminals 1 and 2 of connector X17 on the Control Board (A10)
- 4 With the combi in the steam mode with time on the timer, the door closed and the start switch is depressed
- a The front display will include a lighted bar under the steam symbol
 - When the heat circuit is energized the heat symbol will be energized
 - The cooking mode symbol will be energized.
 - The time display will invert and begin to count down.
 - b The fan circuit is energized by the Control Board (A10) transmitting and receiving a signal from terminals 5,6,7 and 8 on connector X10 to terminals 3,4,5 and 6 of connector X28 on the Gas Board (A20)
 - The Gas board (A20) Transmits a signal from terminal 3 of connector X26 to terminal 3 of connector X12 the Upper Motor Drive (U10.1)
 - ◇ 240 VAC 3 phase is sent from the Motor board to the Oven Fan motor (M1)
 - ◇ Every 120 seconds the rotation of the motor reverses.
 - **NOTE:** If the temperature is less than 212 degrees F than fan will be pulsed on for 2 seconds every 60 seconds after the cabinet set temp (B6) and the bypass probe (B5) are satisfied.
 - The Gas board (A20) Transmits a signal from terminal 7 of connector X26 to terminal 3 of connector X12 the Lower Motor Drive (U10.1)
 - ◇ 240 VAC 3 phase is sent from the Motor board to the Oven Fan motor (M1)
 - ◇ Every 120 seconds the rotation of the motor reverses.
 - ◇ **NOTE:** If the temperature is less than 212 degrees F than fan will be pulsed on for 2 seconds every 60 seconds after the cabinet set temp (B6) and the bypass probe (B5) are satisfied.
 - c The steam generator heat circuit is energized after the signal is received from the motor board that the blower motor is turning
 - A signal is sent from terminal 8 of connector X24 on the Gas Board (A20) to terminal 4 of connector X2 on the Steam Power Burner and Fan Control (U21) selecting the set speed of the combustion blower.
 - ◇ When this speed is attained the signal is sent from terminal 2 of connector X2 on the Steam Power Burner and Fan Control (U21) to terminal 9 of connector X24 on the Gas Board (A20)

- A request for heat is sent from terminal 3 of connector X21 on the Gas Board (A20) to terminal 10 on connector X1 on the Steam Burner Control Module (N21)
 - ◇ 24 VAC is sent from terminal 2 of connector X2 on the Steam Burner Control Module (N21) to the hot surface igniter (R20).
 - ◇ The gas valve is energized allowing gas and air into the burner chamber to be ignited by the hot surface igniter.
 - ◇ The Steam Burner Control Module (N21) senses at least 1.5 micro amps DC from the flame sensor (P1) at terminal 3 of connector X2 and sends a signal from terminal 2 of connector X1 to terminal 11 of connector X25 on the Gas Board (A20).
 - The heat circuit continues until both the cabinet set temperature and the bypass probe (B5) are satisfied
 - ◇ **NOTE:** If the set temperature is above 212 degrees F the hot air circuit will be energized (after the bypass probe is satisfied) until the compartment setting is reached. The steam circuit always takes precedence.
 - d When the condensate box is heated to 140 degrees F at the B3 probe, 120 VAC is sent from terminal 5 of connector X12 to the condenser valve (Y1) until the temperature drops.
 - e When the timer counts to 0 or the core temp probe (B10) reaches the set amount the cycle send and the steam generator reverts to the standby temperature of 190 degrees F.
 - f
- 5 With the combi in the Hot Air mode with time on the timer, the door closed and the start switch is depressed
- a The front display will include a lighted bar under the Hot Air symbol
 - When the heat circuit is energized the heat symbol will be energized
 - The cooking mode symbol will be energized.
 - The time display will invert and begin to count down.
 - b The fan circuit is energized by the Control Board (A10) transmitting and receiving a signal from terminals 5,6,7 and 8 on connector X10 to terminals 3,4,5 and 6 of connector X28 on the Gas Board (A20)
 - The Gas board (A20) Transmits a signal from terminal 3 of connector X26 to terminal 3 of connector X12 the Upper Motor Drive (U10.1)
 - ◇ 240 VAC 3 phase is sent from the Motor board to the Oven Fan motor (M1)
 - ◇ Every 120 seconds the rotation of the motor reverses.
 - **NOTE:** If the temperature is less than 212 degrees F than fan will be pulsed on for 2 seconds every 60 seconds after the cabinet set temp (B6) and the bypass probe (B5) are satisfied.
 - The Gas board (A20) Transmits a signal from terminal 7 of connector X26 to terminal 3 of connector X12 the Lower Motor Drive (U10.1)
 - ◇ 240 VAC 3 phase is sent from the Motor board to the Oven Fan motor (M1)

- ◇ Every 120 seconds the rotation of the motor reverses.
- ◇ **NOTE:** If the temperature is less than 212 degrees F than fan will be pulsed on for 2 seconds every 60 seconds after the cabinet set temp (B6) and the bypass probe (B5) are satisfied.
- c Hot air heat circuit is energized
 - A signal is sent from terminal 2 of connector X24 on the Gas Board (A20) to terminal 4 of connector X2 on the Upper Hot Air Power Burner and Fan Control (U20) selecting the set speed of the combustion blower.
 - ◇ When this speed is attained the signal is sent from terminal 2 of connector X2 on the Upper Hot Air Power Burner and Fan Control (U20) to terminal 3 of connector X24 on the Gas Board (A20)
 - A request for heat is sent from terminal 3 of connector X20 on the Gas Board (A20) to terminal 10 on connector X1 on the Upper Hot Air Control Module (N20)
 - ◇ 24 VAC is sent from terminal 2 of connector X2 on the Upper Hot Air Control Module (N20) to the hot surface igniter (R20).
 - ◇ The gas valve is energized allowing gas and air into the burner chamber to be ignited by the hot surface igniter.
 - ◇ The Upper Hot Air Burner Control Module (N20) senses at least 1.5 micro amps DC from the Flame sensor (P1) at terminal 3 of connector X2 and sends a signal from terminal 2 of connector X1 to terminal 10 of connector X25 on the Gas Board (A20)
- d When the Upper Burner Assembly has proven flame, the Lower Hot Air heat circuit is energized
 - A signal is sent from terminal 8 of connector X24 on the Gas Board (A20) to terminal 4 of connector X2 on the Lower Hot Air Power Burner and Fan Control (U21) selecting the set speed of the combustion blower.
 - ◇ When this speed is attained the signal is sent from terminal 2 of connector X2 on the Hot Air Power Burner and Fan Control (U21) to terminal 8 of connector X24 on the Gas Board (A20)
 - A request for heat is sent from terminal 3 of connector X22 on the Gas Board (A20) to terminal 10 on connector X1 on the Hot Air Control Module (N22)
 - ◇ 24 VAC is sent from terminal 2 of connector X2 on the Hot Air Control Module (N20) to the hot surface igniter (R20).
 - ◇ The gas valve is energized allowing gas and air into the burner chamber to be ignited by the hot surface igniter.
 - ◇ The Hot Air Burner Control Module (N20) senses at least 1.5 micro amps DC from the Flame sensor (P1) at terminal 3 of connector X2 and sends a signal from terminal 2 of connector X1 to terminal 10 of connector X25 on the Gas Board (A20)
- e The heat circuit will remain energized until the cabinet set temperature is reached
- f When the condensate box is heated to 140 degrees F at the B3 probe, 120 VAC is sent from terminal 5 of connector X12 to the condenser valve (Y1) until the temperature drops.
- g If the “Crisp and Tasty” mode is selected

- 120 VAC is sent from terminal 6 of connector X12 on the Control Board (A10) to the Dehumidification Valve (Y2) to pull the humidity out of the cabinet down the drain.
 - ◇ In the light and medium modes (one and two drops in the display) the Y2 valve will be energized until the bypass probe (B5) is satisfied.
 - ◇ In the full mode (3 drops in the display) the Y2 valve will be energized continuously.
- h When the timer counts to 0 or the core temp probe (B10) reaches the set amount the cycle ends and the steam generator reverts to the standby temperature of 190 degree F.
 -
- i The heat circuit will remain energized until the cabinet set temperature is reached
- j When the condensate box is heated to 140 degrees F at the B3 probe, 120 VAC is sent from terminal 5 of connector X12 to the condenser valve (Y1) until the temperature drops.
- k If the “Crisp and Tasty” mode is selected
 - 120 VAC is sent from terminal 6 of connector X12 on the Control Board (A10) to the Dehumidification Valve (Y2) to pull the humidity out of the cabinet down the drain.
 - ◇ In the light and medium modes (one and two drops in the display) the Y2 valve will be energized until the bypass probe (B5) is satisfied.
 - ◇ In the full mode (3 drops in the display) the Y2 valve will be energized continuously.
- l When the timer counts to 0 or the core temp probe (B10) reaches the set amount the cycle ends and the steam generator reverts to the standby temperature of 190 degree F.
- 6 With the combi in the Combi mode with time on the timer, the door closed and the start switch is depressed
 - a The front display will include a lighted bar under the Combi symbol
 - When the heat circuit is energized the heat symbol will be energized
 - The cooking mode symbol will be energized.
 - The time display will invert and begin to count down.
 - b The fan circuit is energized by the Control Board (A10) transmitting and receiving a signal from terminals 5,6,7 and 8 on connector X10 to terminals 3,4,5 and 6 of connector X28 on the Gas Board (A20)
 - The Gas board (A20) Transmits a signal from terminal 4 of connector X26 to terminal 2 of connector X12 the Motor Drive (U10)
 - ◇ 240 VAC 3 phase is sent from the Motor board to the Oven Fan motor (M1)
 - ◇ Every 120 seconds the rotation of the motor reverses.
 - ◇ **NOTE:** If the temperature is less than 212 degrees F than fan will be pulsed on for 2 seconds every 60 seconds after the cabinet set temp (B6) and the bypass probe (B5) are satisfied.
- 7 With the combi in the Rethermalization mode with time on the timer, the door closed and the start switch is depressed
 - a The front display will include a lighted bar under the Retherm symbol

- When the heat circuit is energized the heat symbol will be energized
 - The cooking mode symbol will be energized.
 - The time display will invert and begin to count down.
- b The fan circuit is energized by the Control Board (A10) transmitting and receiving a signal from terminals 5,6,7 and 8 on connector X10 to terminals 3,4,5 and 6 of connector X28 on the Gas Board (A20)
- The Gas board (A20) Transmits a signal from terminal 4 of connector X26 to terminal 2 of connector X12 the Motor Drive (U10)
 - ◇ 220 VAC 3 phase is sent from the Motor board to the Oven Fan motor (M1)
 - ◇ Every 120 seconds the rotation of the motor reverses.
 - ◇ **NOTE:** If the temperature is less than 212 degrees F than fan will be pulsed on for 2 seconds every 60 seconds after the cabinet set temp (B6) and the bypass probe (B5) are satisfied.

PARTS LIST

LABEL	DESCRIPTION	PART NO.	LOCATION	LABEL	DESCRIPTION	PART NO.	LOCATION
-A10	CONTROL BOARD (SM 5010)	C5019100	3				
-A11	OPERATION BOARD (BM 5010)	C5019101	3	-U20	POWER BURNER ASSY, HOT AIR	-	5.D6
-A12	PICTO BOARD (OPTION)	C5019105	3.B1		FAN, BURNER, 120VAC	C5018007	
-A13	I.D. MODULE	C5019102	3.B8	-U21	POWER BURNER ASSY, GEN.	-	6.D6
-A20	GAS BOARD (GM5010)	C5019103	4		FAN, BURNER, 120VAC	C5018007	
-B1	WATER LEVEL PROBE	C5019003	3.A6	-U22	POWER BURNER ASSY, HOT AIR.	-	7.D6
-B3	CONDENSOR PROBE	C5016007	3.B4		FAN, BURNER, 120VAC	C5018007	
-B4	STEAM GEN PROBE	C5016007	3.B3	-W1	CABLE, 9 PIN COM.	300533	3.C3
-B5	BYPASS PROBE	C5016007	3.B4	-Y1	VALVE, CONDENSER, 120VAC	300455	3.E4
-B6	OVEN PROBE	C5016006	3.B4		NOISE FILTER (RC)	300407	3.E4
-B7.1	OVEN HI-TEMP THERMOSTAT	C5001041	5.B7	-Y10	VALVE ASSY, 2 WAY, 120VAC	300456	3.E
-B7.2	GEN. HI-TEMP THERMOSTAT	1089952	6.B4		-Y2 VALVE, DEHUMID.	-	3.E
-B8	GEN. HI-TEMP PROBE	C5016003	3.B3		-Y3 VALVE, GEN. FILL	-	3.E
-B10	CORE TEMP. PROBE (KTM CTC)	C5013001	3.B4		NOISE FILTER (RC)	-	3.E
-F1.1	FUSE, 3A	KE52936-6	2.B3		VALVE ASSY, 3 WAY, 120VAC(CLEANING OPTION)	300363	3
-F2.1	FUSE, 1A	300418	3.E3		-Y2 VALVE, DEHUMID.	-	3
-F10.1, -F10.2	FUSE, 20A	300471	2.B5, 2.B8		-Y3 VALVE, GEN. FILL	-	3
-G1	POWER SUPPLY, 12VDC	300350	2.C3		-Y21 VALVE, CLEAN/RINSE	-	3
-H5.1, -H5.2	OVEN LAMP	C5005043	3.E3, 3.E2		NOISE FILTER (RC)	-	
-K0	RELAY, 120VAC	03524	5.E7	-Y20	PUMP, RINSING AGENT, 120VAC(CLEANING OPTION)	300352	3.E7
	SOCKET	300473		-Y22	PUMP, CLEANING AGENT, 120VAC(CLEANING OPTION)	300352	3.E8
-M1, M2	MOTOR, CONVECTION	C50180221	2.E4, 2.E6	-Y23	PUMP, CLEANING AGENT, 120VAC(CLEANING OPTION)	300352	3.E8
-M3.1, -M3.2	COOLING FAN	C5018023	3.E1	-Z1, -Z2	LINE FILTER, 20A	300472	2.B1, 2.C1
-M4	PUMP, GEN.	300506	3.E6				
-N20	BURNER ASSY, HOT AIR	-	5.D3				
	VALVE, GAS, 120VAC	C6016009					
	CONTROL, BURNER, 120VAC	C6016023					
-N21	BURNER ASSY, GEN.	-	6.D3				
	VALVE, GAS, 120VAC	C6016009					
	CONTROL, BURNER, 120VAC	C6016023					
-N22	BURNER ASSY, HOT AIR	-	7.D3				
	VALVE, GAS, 120VAC	C6016009					
	CONTROL, BURNER, 120VAC	C6016023					
-P1, -P2, -P3	FLAME SENSOR	C4018000	5.D3, 6.D3, 7.D3				
-R20, -R21, -R22	IGNITOR, HOT SURFACE	C4018001	5.E4, 6.E3, 7.E3				
-S1	SWITCH, CONTROL POWER	300278	2.A1				
-S2	PRESSURE SWITCH	C5013051	3.A5				
-S7	DOOR SWITCH	C5003075	3.A6				
-T1	TRANSFORMER, 120V/24V	300419	5.C2				
-T2	TRANSFORMER, 120V/24V	300419	6.C2				
-T3	TRANSFORMER, 120V/24V	300419	7.C2				
-U10.1, -U10.2	AC DRIVE	300462	2.C5, 2.C7				

CONNECTION NUMBERING EXAMPLE

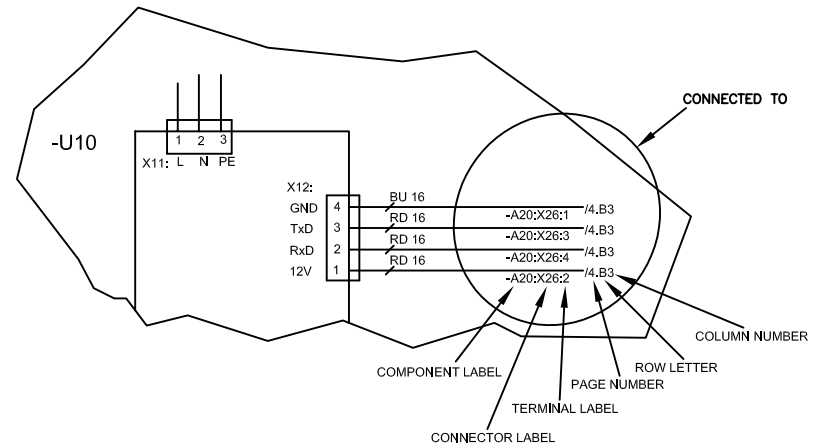

THIS DESIGN DESCRIBES A PROPRIETARY ITEM AND IS THE PROPERTY OF CLEVELAND RANGE. THIS DRAWING IS NOT TO BE COPIED OR USED WITHOUT THE APPROVAL OF CLEVELAND RANGE.

CLEVELAND RANGE, LLC
1333 East 179th St., Cleveland, Ohio 44110-2574

TITLE
WIRING DIAGRAM
OGB 20.20

VOLTAGE: 110-120
WATTAGE: -
CURRENT: 22.5A

DRAWN BY
DRL
DATE
9-20-05

DRAWING NO.
300497
SIZE
B

SHEET 1 OF 10

REV
E

WIRING DIAGRAM

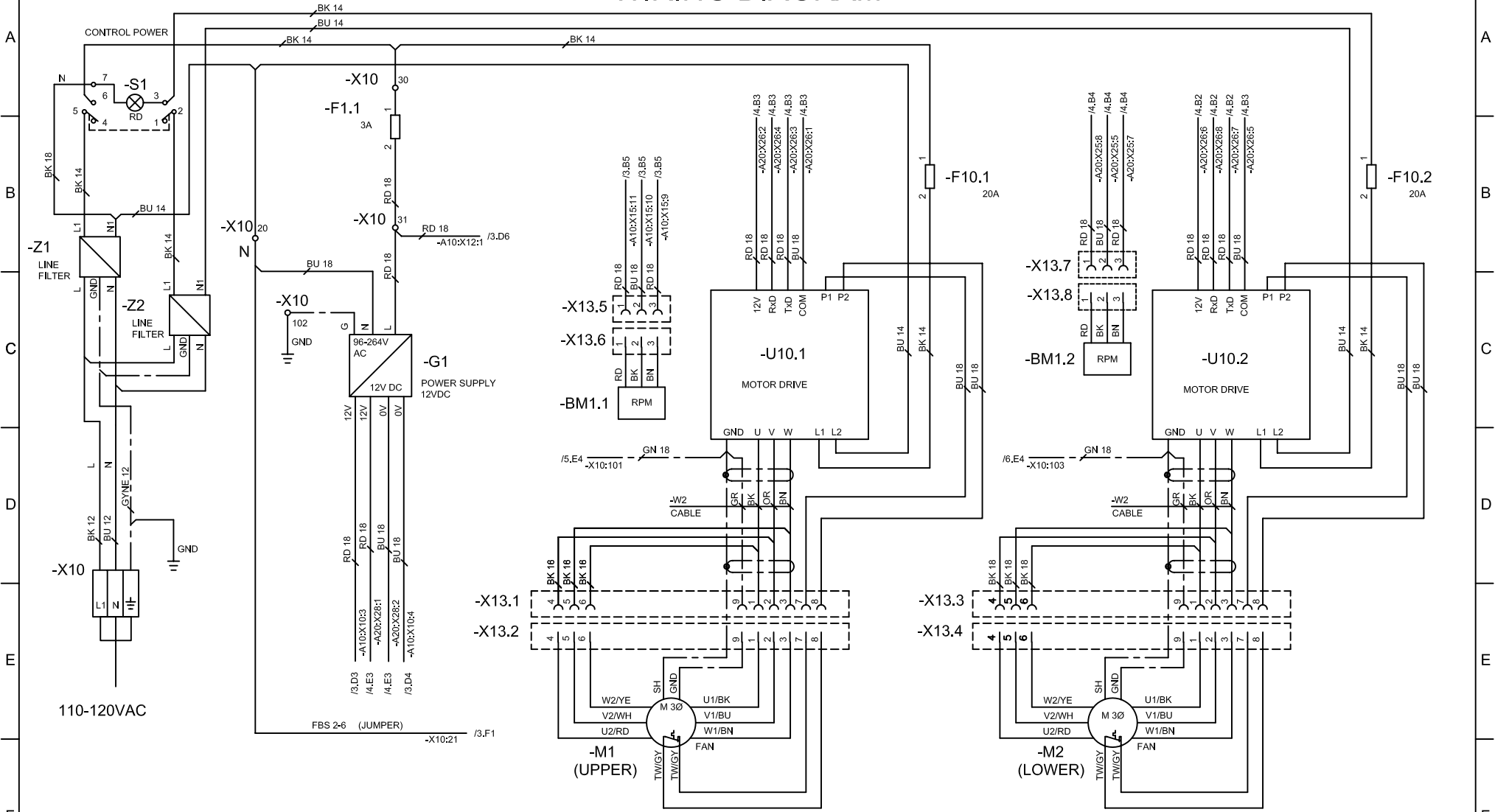

<p style="font-size: small;">THIS DESIGN DESCRIBES A PROPRIETARY ITEM AND IS THE PROPERTY OF CLEVELAND RANGE. THIS DRAWING IS NOT TO BE COPIED OR USED WITHOUT THE APPROVAL OF CLEVELAND RANGE.</p> <p style="text-align: center;">CLEVELAND RANGE, LLC 1333 East 179th St., Cleveland, Ohio 44110-2574</p>	<p style="text-align: center;">TITLE WIRING DIAGRAM OGB 20.20</p>	<p>VOLTAGE: 110-120 WATTAGE: - CURRENT: 22.5A</p>	<p style="font-size: small;">DRAWN BY DRL</p> <p style="font-size: small;">DATE 9-20-05</p>	<p style="font-size: small;">DRAWING NO. 300497</p> <p style="font-size: small;">SIZE B</p>	<p style="font-size: small;">REV E</p>
			<p style="font-size: small;">SHEET 2 OF 10</p>		

WIRING DIAGRAM

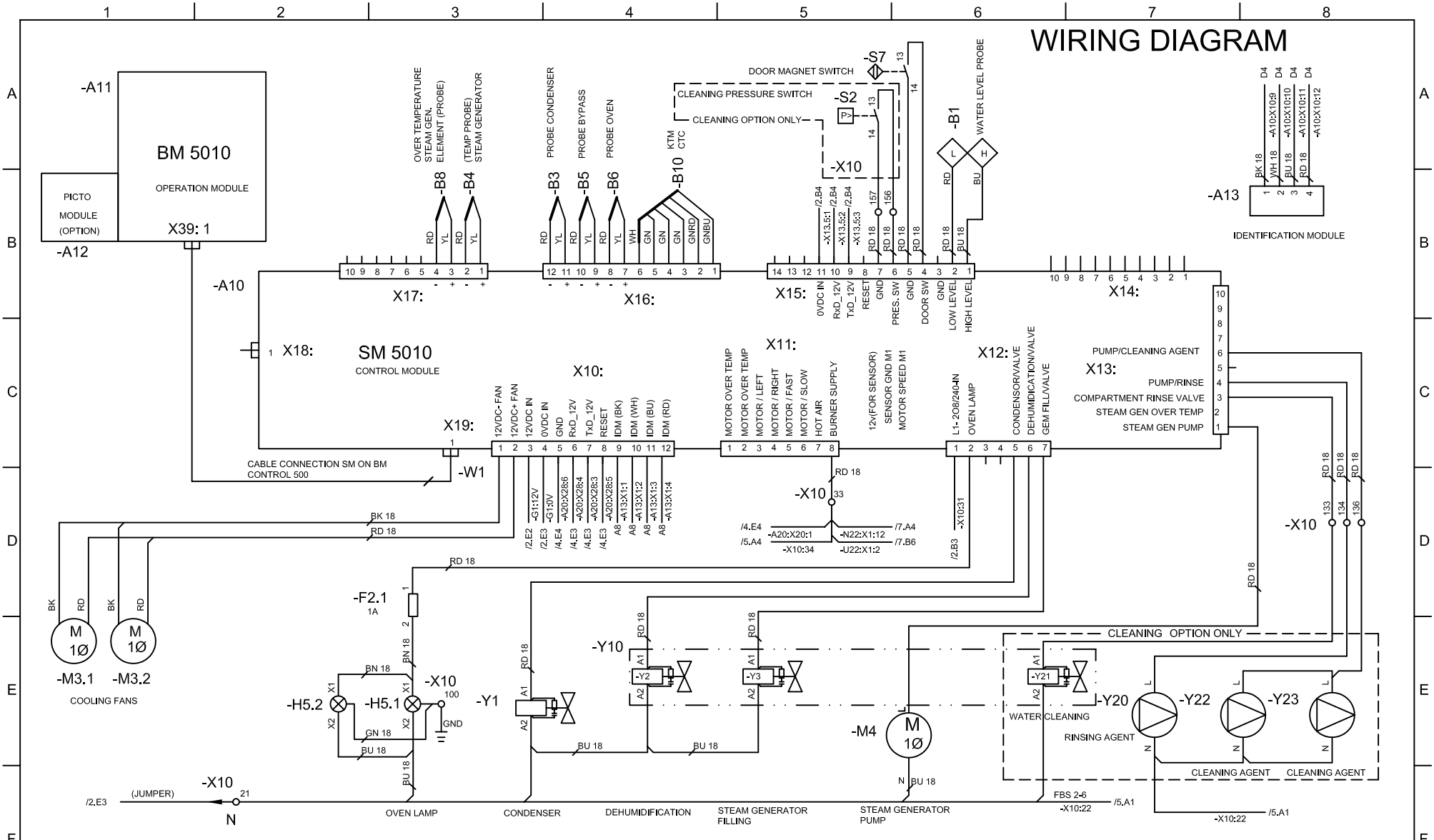

THIS DESIGN DESCRIBES A PROPRIETARY ITEM AND IS THE PROPERTY OF CLEVELAND RANGE. THIS DRAWING IS NOT TO BE COPIED OR USED WITHOUT THE APPROVAL OF CLEVELAND RANGE.

CLEVELAND RANGE, LLC
1333 East 179th St., Cleveland, Ohio 44110-2574

TITLE
WIRING DIAGRAM
OGB 20.20

VOLTAGE: 110-120
WATTAGE: -
CURRENT: 22.5A

DRAWN BY: DRL
DATE: 9-20-05

DRAWING NO.: 300497
SIZE: B

REV: E
SHEET 3 OF 10

WIRING DIAGRAM

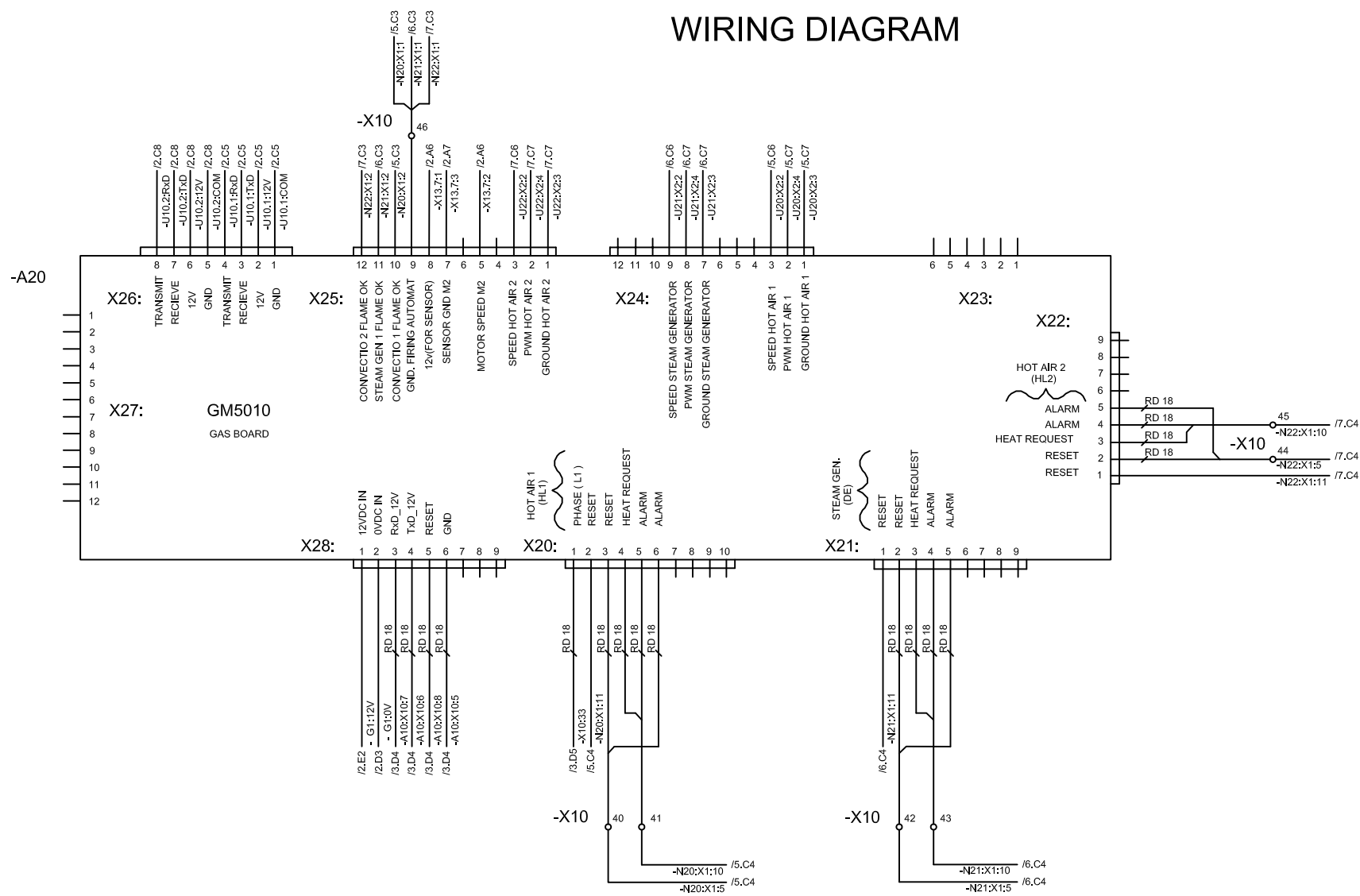

THIS DESIGN DESCRIBES A PROPRIETARY ITEM AND IS THE PROPERTY OF CLEVELAND RANGE. THIS DRAWING IS NOT TO BE COPIED OR USED WITHOUT THE APPROVAL OF CLEVELAND RANGE.	TITLE WIRING DIAGRAM OGB 20.20	VOLTAGE: 110-120 WATTAGE: - CURRENT: 22.5A	DRAWN BY DRL DATE 9-20-05	DRAWING NO. 300497 SIZE B SHEET 4 OF 10	REV E
CLEVELAND RANGE, LLC 1333 East 179th St., Cleveland, Ohio 44110-2574					

WIRING DIAGRAM

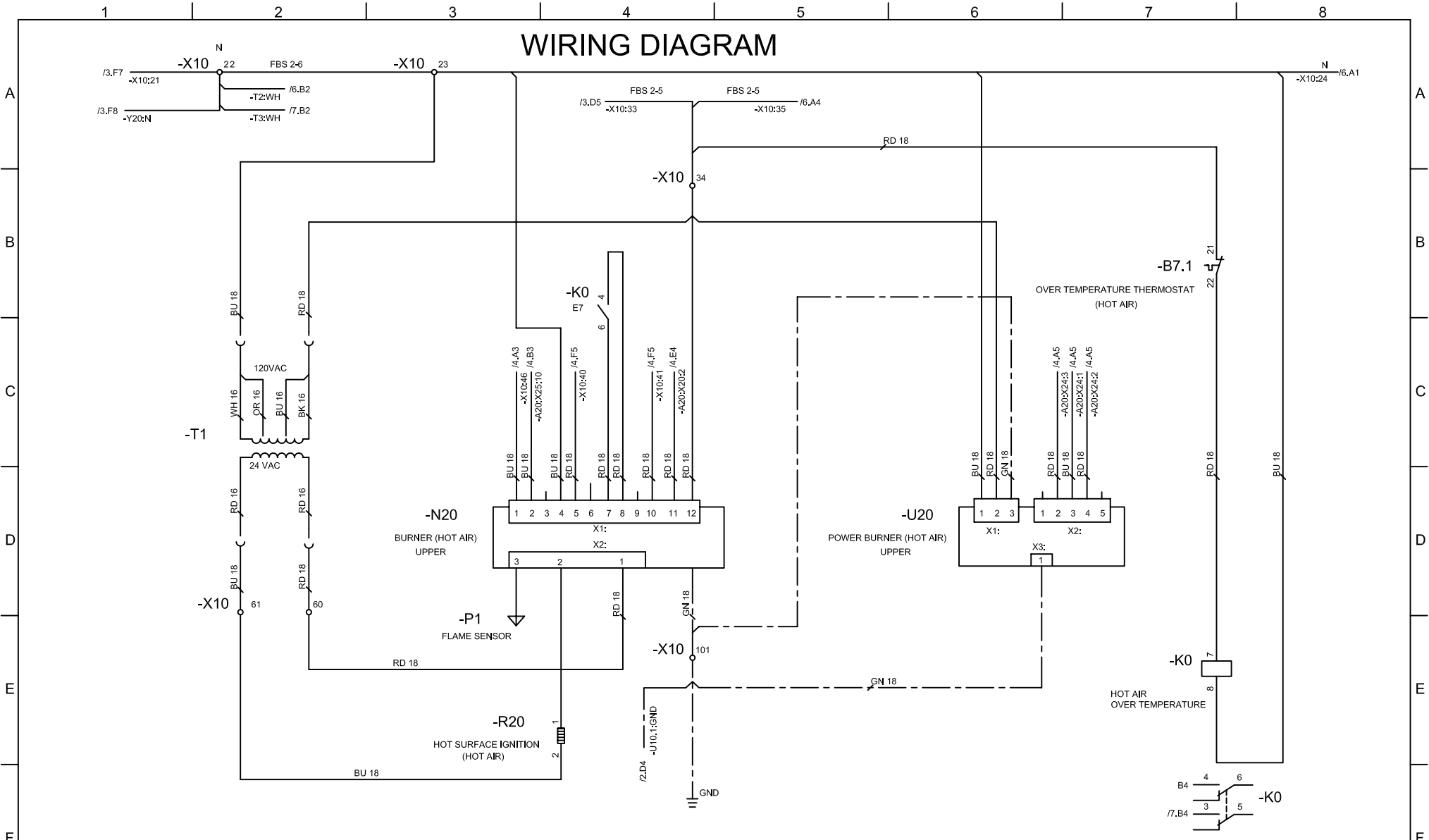

THIS DESIGN DESCRIBES A PROPRIETARY ITEM AND IS THE PROPERTY OF CLEVELAND RANGE. THIS DRAWING IS NOT TO BE COPIED OR USED WITHOUT THE APPROVAL OF CLEVELAND RANGE.	TITLE WIRING DIAGRAM OGB 20.20	VOLTAGE: 110-120 WATTAGE: - CURRENT: 22.5A	DRAWN BY DRL	DRAWING NO. 300497	REV E
CLEVELAND RANGE, LLC 1333 East 179th St., Cleveland, Ohio 44110-2574			DATE 9-20-05	SIZE B	SHEET 5 OF 10

WIRING DIAGRAM

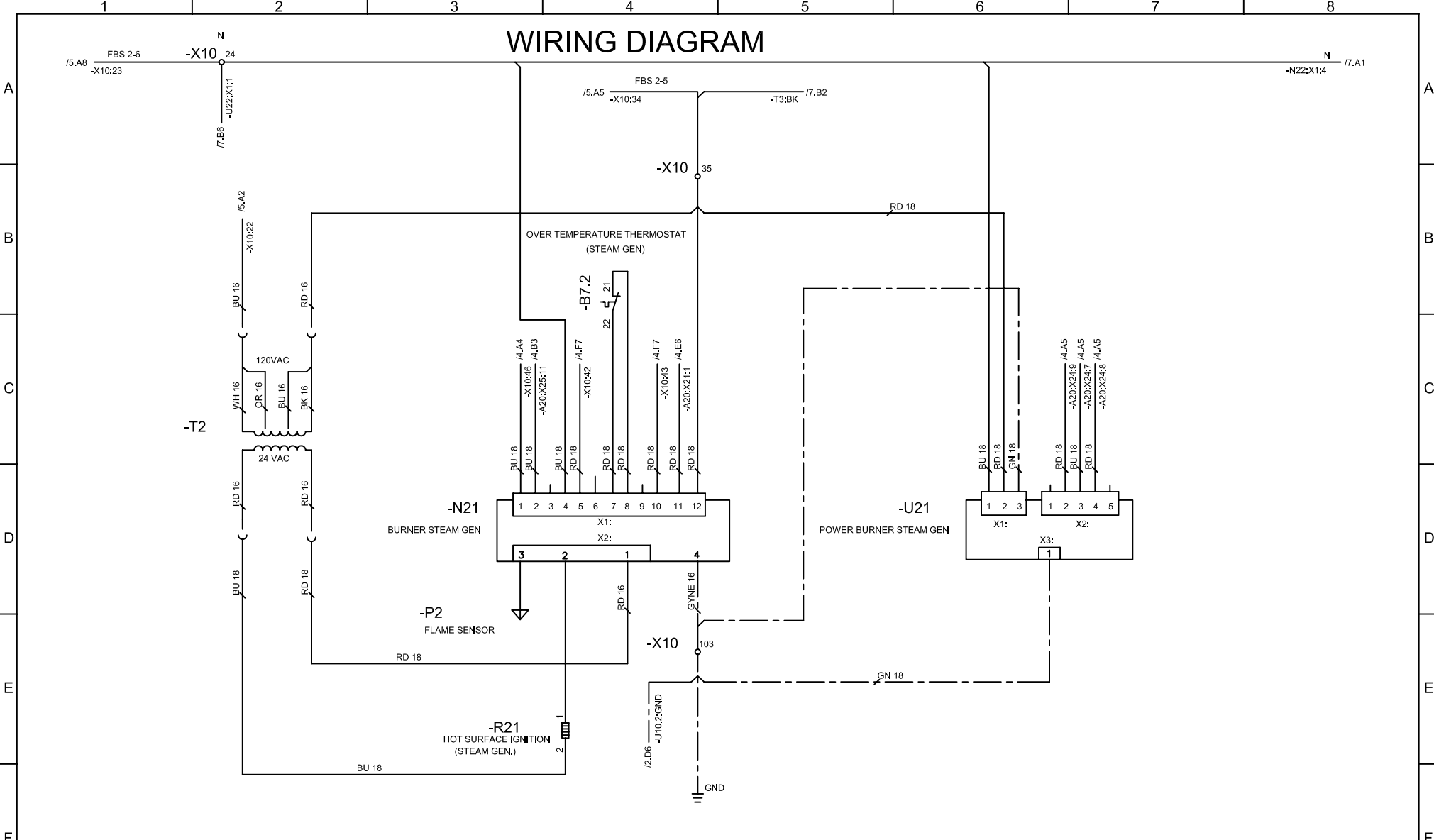

THIS DESIGN DESCRIBES A PROPRIETARY ITEM AND IS THE PROPERTY OF CLEVELAND RANGE. THIS DRAWING IS NOT TO BE COPIED OR USED WITHOUT THE APPROVAL OF CLEVELAND RANGE.	TITLE WIRING DIAGRAM OGB.20.20	VOLTAGE: 110-120 WATTAGE: - CURRENT: 22.5A	DRAWN BY DRL	DRAWING NO. 300497	REV E
CLEVELAND RANGE, LLC 1333 East 179th St., Cleveland, Ohio 44110-2574			DATE 9-20-05	SIZE B	SHEET 6 OF 10

WIRING DIAGRAM

1 2 3 4 5 6 7 8

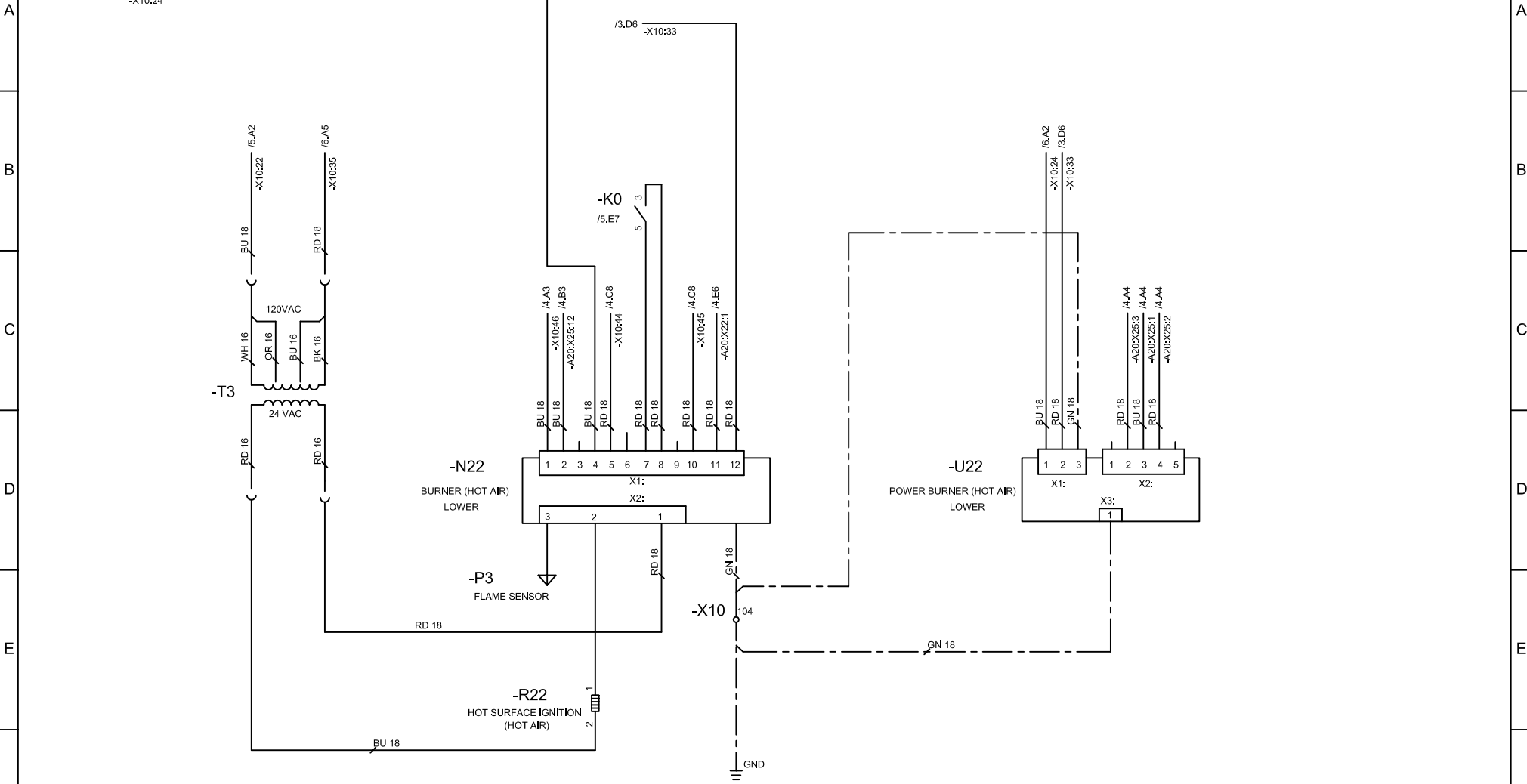

THIS DESIGN DESCRIBES A PROPRIETARY ITEM AND IS THE PROPERTY OF CLEVELAND RANGE. THIS DRAWING IS NOT TO BE COPIED OR USED WITHOUT THE APPROVAL OF CLEVELAND RANGE.	TITLE WIRING DIAGRAM OGB 20.20	VOLTAGE: 110-120 WATTAGE: - CURRENT: 22.5A	DRAWN BY DRL	DRAWING NO. 300497	REV E
CLEVELAND RANGE, LLC 1333 East 179th St., Cleveland, Ohio 44110-2574			DATE 9-20-05	SIZE B	SHEET 7 OF 10

1 2 3 4 5 6 7 8

LADDER DIAGRAM

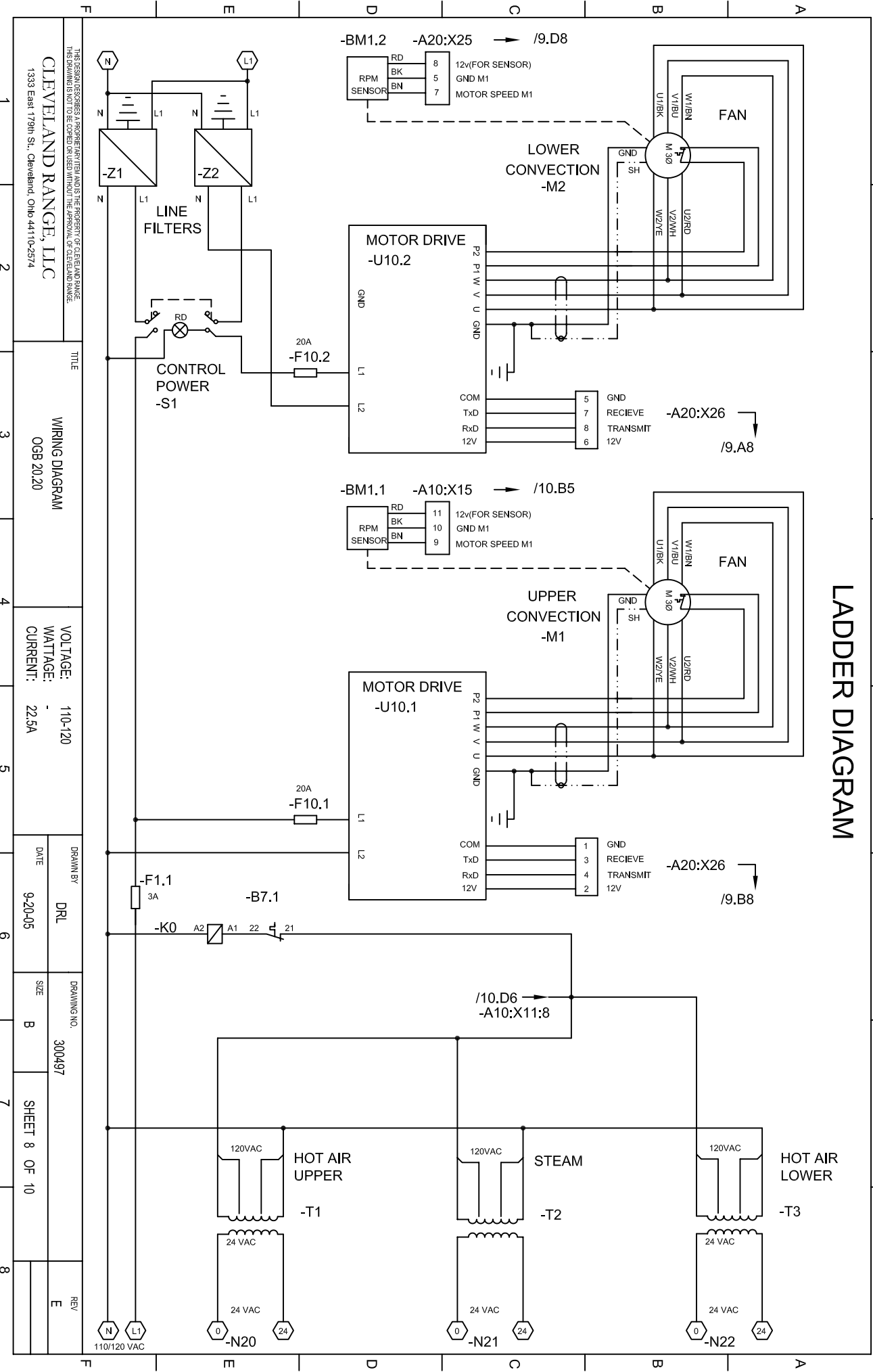

THESE DRAWINGS ARE A REPRESENTATION AND NOT THE PROPERTY OF CLEVELAND RANGE. THIS DRAWING IS NOT TO BE COPIED OR USED WITHOUT THE APPROVAL OF CLEVELAND RANGE.

CLEVELAND RANGE, LLC
 1333 East 179th St., Cleveland, Ohio 44116-2574

TITLE
WIRING DIAGRAM
 OGB 20.20

VOLTAGE: 110-120
 WATTAGE: -
 CURRENT: 22.5A

DRAWN BY
 DRL
 DATE
 9-20-05

DRAWING NO.
 300497

SIZE
 B

SHEET 8 OF 10

REV
 E

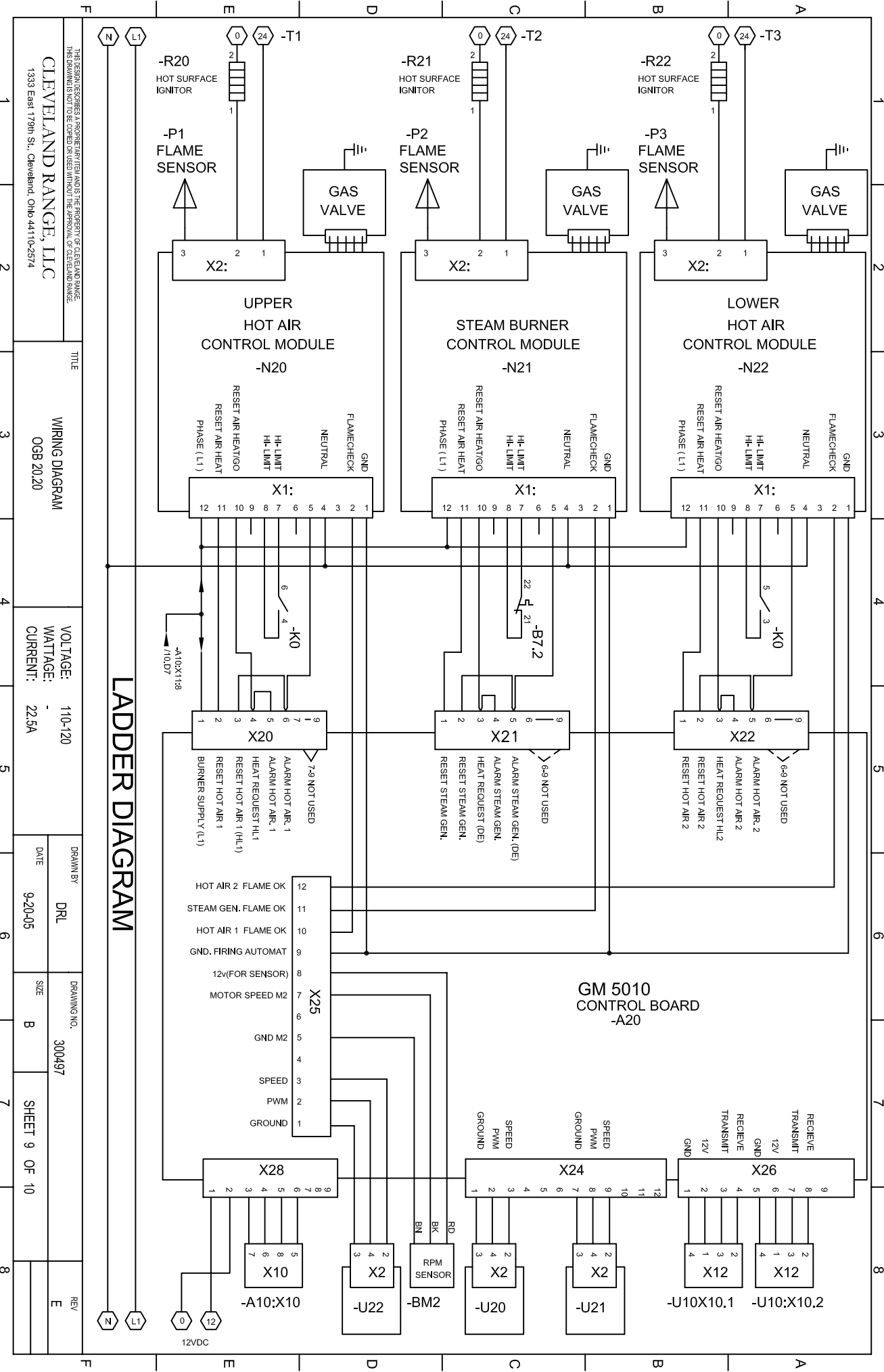

LADDER DIAGRAM

THE DESIGN DESCRIBES A PROPRIETARY AND IS THE PROPERTY OF CLEVELAND RANGE. THIS DRAWING IS NOT TO BE COPIED OR USED WITHOUT THE APPROVAL OF CLEVELAND RANGE.	
CLEVELAND RANGE, LLC 1333 East 179th St., Cleveland, Ohio 44110-2574	TITLE WIRING DIAGRAM QCB 20.20
VOLTAGE: 110-120 WATTAGE: - CURRENT: 22.5A	DRAWN BY: DRL DATE: 9-20-05 DRAWING NO.: 300497
REV	SHEET 9 OF 10

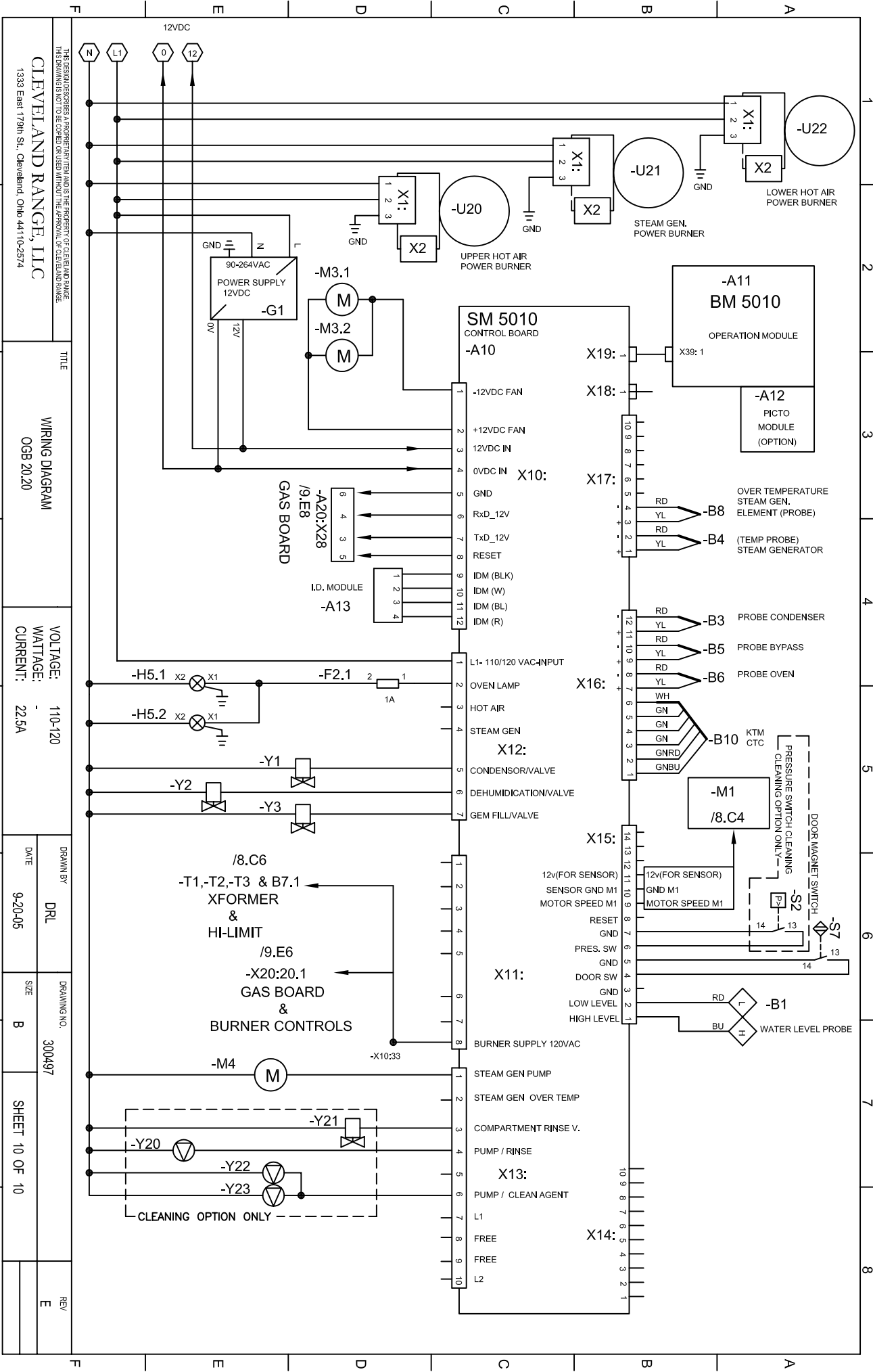

THE DESIGN DESCRIBES A PROPRIETARY AND IS THE PROPERTY OF CLEVELAND RANGE. THIS DRAWING IS NOT TO BE COPIED OR USED WITHOUT THE APPROVAL OF CLEVELAND RANGE.

CLEVELAND RANGE, LLC
1333 East 179th St., Cleveland, Ohio 44110-2574

TITLE
WIRING DIAGRAM
OGB 20/20

VOLTAGE: 110-120
WATTAGE: -
CURRENT: 22.5A

DRAWN BY: DRL
DATE: 9-20-05

DRAWING NO.: 300497
SIZE: B

SHEET 10 OF 10

REV: E

CLEVELAND RANGE OGS 20.20 SEQUENCE OF OPERATIONS

When using these instructions refer to the OGS 20.20 wiring schematic.

- 1 When 120 VAC is applied to the combi, it is sent to the Power Control Switch (S1).
- 2 When the Power Control Switch (S1) is closed
 - a The red light in the switch is energized.
 - b 120 VAC is sent through the Z1 Filter and the 20 amp fuse (F10.1) to L1 and L2 on the Motor Drive (U10.1)
 - c 120 VAC is sent through the Z2 Filter and the 20 amp fuse (F10.2) to L1 and L2 on the Motor Drive (U10.2)
 - d 120vac is sent through the 2 amp fuse (F1.1) to
 - The primary of the Upper Hot Air 24v Transformer (T1)
 - ◊ 24 VAC is sent from the secondary of the transformer to the Upper Hot Air Burner Control (N20)
 - The primary of the Lower Hot Air 24v Transformer (T3)
 - ◊ 24 VAC is sent from the secondary of the transformer to the Lower Hot Air Burner Control (N22)
 - To terminal 12 of connector X1 on the Hot Air Burner Control (N20)
 - To terminal 12 of connector X1 on the Lower Hot Air Burner Control (N22)
 - The 12 VDC Power Supply (G1)
 - ◊ 12 VDC is sent to terminals 1 and 2 of connector X20 on the Gas Board (A20)
 - ◊ 12 VDC is sent to terminal 3 and 4 of connector X10 on the Control Board (A10)
 - To terminal 2 of connector X1 on the Hot Air Power Burner and Fan Control (U20)
 - To terminal 2 of connector X1 on the Lower Hot Air Burner and Fan Control (U22)
 - To terminal 1 of connector X12 on the Control Board (A10)
 - e With 120 VAC to the Control Board (A10) The Operation Board (A11) is energized
 - An alarm will sound for one second
 - All the LED's and the display will energize one at a time.
 - "STARTING" will be displayed for 3 seconds
 - "Please wait" will be displayed
 - The international model number will be displayed
 - The time and date will be displayed and this will continue until the on/off switch is depressed.
- 3 When the ON/OFF is depressed with the combi in the steam mode
 - a The display will show the set temperature and set time.
- 4 With the combi in the steam mode with time on the timer, the door closed and the start switch is depressed

- a The front display will include a lighted bar under the steam symbol
 - When the heat circuit is energized the heat symbol will be energized
 - The cooking mode symbol will be energized.
 - The time display will invert and begin to count down.
- b The fan circuit is energized by the Control Board (A10) transmitting and receiving a signal from terminals 5,6, and 7 on connector X10 to connector X12 on the Motor Drive Board (U10).
 - The motor Drive Board sends a signal through the thermal switch in the motor from Terminal 5 and receives on terminal 6
 - If the thermal switch is not open the Motor Drive Board (U10) sends 240 VAC 3 phase to the motor.
 - The motor reverses direction every 120 seconds with a 15 second coast.
- c Hot air heat circuit is energized
 - A signal is sent from terminal 8 of connector X15 on the Control Board (A10) to terminal 4 of connector X2 on the Hot Air Power Burner and Fan Control (U20) selecting the set speed of the combustion blower.
 - ◇ When this speed is attained the signal is sent from terminal 2 of connector X2 on the Hot Air Power Burner and Fan Control (U20) to terminal 2 of connector X15 on the Control Board (A10)
 - A request for heat is sent from terminal 3 of connector X12 on the Control Board (A10) to terminal 10 on connector X1 on the Hot Air Control Module (N20)
 - ◇ 24 VAC is sent from terminal 2 of connector X2 on the Hot Air Control Module (N20) to the hot surface igniter (R20).
 - ◇ The gas valve is energized allowing gas and air into the burner chamber to be ignited by the hot surface igniter.
 - ◇ The Hot Air Burner Control Module (N20) senses at least 1.5 micro amps DC from the flame sensor (P1) at terminal 3 of connector X2 and sends a signal from terminal 2 of connector X1 to terminal 12 of connector X15 on the Control Board (A10)
 - The heat circuit will remain energized until the cabinet set temperature is reached as sensed at probe B6.
- d The steam circuit is energized
 - 120 VAC is sent from terminal 4 of connector X12 on the Control Board (A10) to the coil of the Y3 solenoid allowing water to be thrown against the element until the bypass probe (B5) senses 183 degrees F.
 - ◇ **NOTE:** If the set temperature is above 212 degrees F the hot air circuit will be energized (after the by pass probe is satisfied) until the compartment setting is reached.
- e When the condensate box is heated to 140 degrees F at the B3probe, 120 VAC is sent from terminal 5 of connector X12 to the condenser valve (Y1) until the temperature drops.
- f When the timer counts to 0 or the core temp probe (B10) reaches the set amount the cycle ends and the steam generator reverts to the standby temperature of 190-degree F.

- 5 With the combi in the Hot Air mode with time on the timer, the door closed and the start switch is depressed
 - a The front display will include a lighted bar under the Hot Air symbol
 - When the heat circuit is energized the heat symbol will be energized
 - The cooking mode symbol will be energized.
 - The time display will invert and begin to count down.
 - b The fan circuit is energized by the Control Board (A10) transmitting and receiving a signal from terminals 5,6, and 7 on connector X10 to connector X12 on the Motor Drive Board (U10).
 - The motor Drive Board sends a signal through the thermal switch in the motor from Terminal 5 and receives on terminal 6
 - If the thermal switch is not open the Motor Drive Board (U10) sends 240 VAC 3 phase to the motor.
 - The motor reverses direction every 120 seconds with a 15 second coast.
 - **NOTE:** If the set temperature is less than 212 degrees F than fan will be pulsed on for 2 seconds every 60 seconds after the cabinet set temp (B6).
 - c Hot air heat circuit is energized
 - A signal is sent from terminal 8 of connector X15 on the Control Board (A10) to terminal 4 of connector X2 on the Hot Air Power Burner and Fan Control (U20) selecting the set speed of the combustion blower.
 - ◇ When this speed is attained the signal is sent from terminal 2 of connector X2 on the Hot Air Power Burner and Fan Control (U20) to terminal 2 of connector X15 on the Control Board (A10)
 - A request for heat is sent from terminal 3 of connector X12 on the Control Board (A10) to terminal 10 on connector X1 on the Hot Air Control Module (N20)
 - ◇ 24 VAC is sent from terminal 2 of connector X2 on the Hot Air Control Module (N20) to the hot surface igniter (R20).
 - ◇ The gas valve is energized allowing gas and air into the burner chamber to be ignited by the hot surface igniter.
 - ◇ The Hot Air Burner Control Module (N20) senses at least 1.5 micro amps DC from the flame sensor (P1) at terminal 3 of connector X2 and sends a signal from terminal 2 of connector X1 to terminal 12 of connector X15 on the Control Board (A10)
 - The heat circuit will remain energized until the cabinet set temperature is reached as sensed at probe B6.
 - d When the condensate box is heated to 140 degrees F at the B3probe, 120 VAC is sent from terminal 5 of connector X12 to the condenser valve (Y1) until the temperature drops.
 - e If the “Crisp and Tasty” mode is selected
 - 120 VAC is sent from terminal 6 of connector X12 on the Control Board (A10) to the Dehumidification Valve (Y2) to pull the humidity out of the cabinet down the drain.
 - ◇ In the light and medium modes (one and two drops in the display) the Y2 valve will be energized until the bypass probe (B5) is satisfied.

- ◇ In the full mode (3 drops in the display) the Y2 valve will be energized continuously.
 - f When the timer counts to 0 or the core temp probe (B10) reaches the set amount the cycle .
- 6 With the combi in the Combi mode with time on the timer, the door closed and the start switch is depressed
 - a The front display will include a lighted bar under the Combi symbol
 - When the heat circuit is energized the heat symbol will be energized
 - The cooking mode symbol will be energized.
 - The time display will invert and begin to count down.
 - b The fan circuit is energized by the Control Board (A10) transmitting and receiving a signal from terminals 5,6, and 7 on connector X10 to connector X12 on the Motor Drive Board (U10).
 - The motor Drive Board sends a signal through the thermal switch in the motor from Terminal 5 and receives on terminal 6
 - If the thermal switch is not open the Motor Drive Board (U10) sends 240 VAC 3 phase to the motor.
 - The motor reverses direction every 120 seconds with a 15 second coast.
 - c Hot air heat circuit is energized
 - A signal is sent from terminal 8 of connector X15 on the Control Board (A10) to terminal 4 of connector X2 on the Hot Air Power Burner and Fan Control (U20) selecting the set speed of the combustion blower.
 - ◇ When this speed is attained the signal is sent from terminal 2 of connector X2 on the Hot Air Power Burner and Fan Control (U20) to terminal 2 of connector X15 on the Control Board (A10)
 - A request for heat is sent from terminal 3 of connector X12 on the Control Board (A10) to terminal 10 on connector X1 on the Hot Air Control Module (N20)
 - ◇ 24 VAC is sent from terminal 2 of connector X2 on the Hot Air Control Module (N20) to the hot surface igniter (R20).
 - ◇ The gas valve is energized allowing gas and air into the burner chamber to be ignited by the hot surface igniter.
 - ◇ The Hot Air Burner Control Module (N20) senses at least 1.5 micro amps DC from the flame sensor (P1) at terminal 3 of connector X2 and sends a signal from terminal 2 of connector X1 to terminal 12 of connector X15 on the Control Board (A10)
 - The heat circuit will remain energized until the cabinet set temperature is reached as sensed at probe B6.
 - d The steam circuit is energized.
 - 120 VAC is sent from terminal 4 of connector X12 on the Control Board (A10) to the coil of the Y3 solenoid allowing water to be thrown against the element until the bypass probe (B5) senses 183 degrees F.
 - The heat circuit will remain energized until the cabinet set temperature is reached

- If the bypass probe (B5) drops below the set level the steam circuit will start again.
 - e When the condensate box is heated to 140 degrees F at the B3probe, 120 VAC is sent from terminal 5 of connector X12 to the condenser valve (Y1) until the temperature drops.
 - f If the “Crisp and Tasty” mode is selected
 - 120 VAC is sent from terminal 6 of connector X12 on the Control Board (A10) to the Dehumidification Valve (Y2) to pull the humidity out of the cabinet down the drain.
 - ◇ In the light and medium modes (one and two drops in the display) the Y2 valve will be energized until the bypass probe (B5) is satisfied.
 - ◇ In the full mode (3 drops in the display) the Y2 valve will be energized continuously.
 - g When the timer counts to 0 or the core temp probe (B10) reaches the set amount the cycle ends and the steam generator reverts to the standby temperature of 190-degree F.
- 7 With the combi in the Rethermalization mode with time on the timer, the door closed and the start switch is depressed
- a The front display will include a lighted bar under the Retherm symbol
 - When the heat circuit is energized the heat symbol will be energized
 - The cooking mode symbol will be energized.
 - The time display will invert and begin to count down.
 - b The fan circuit is energized by the Control Board (A10) transmitting and receiving a signal from terminals 5,6,7 and 8 on connector X10 to terminals 3,4,5 and 6 of connector X28 on the Gas Board (A20)
 - c The Gas board (A20) Transmits a signal from terminal 4 of connector X26 to the Motor Drive.
 - The motor Drive Board sends a signal through the thermal switch in the motor from Terminal 5 and receives on terminal 6
 - If the thermal switch is not open the Motor Drive Board (U10) sends 220 VAC 3 phase to the motor.
 - The motor reverses direction every 120 seconds with a 15 second coast.
 - **NOTE:** If the set temperature is less than 212 degrees F than fan will be pulsed on for 2 seconds every 60 seconds after the cabinet set temp (B6).
 - d Hot air heat circuit is energized
 - A signal is sent from terminal 8 of connector X15 on the Control Board (A10) to terminal 4 of connector X2 on the Hot Air Power Burner and Fan Control (U20) selecting the set speed of the combustion blower.
 - ◇ When this speed is attained the signal is sent from terminal 2 of connector X2 on the Hot Air Power Burner and Fan Control (U20) to terminal 2 of connector X15 on the Control Board (A10)
 - A request for heat is sent from terminal 3 of connector X12 on the Control Board (A10) to terminal 10 on connector X1 on the Hot Air Control Module (N20)
 - ◇ 24 VAC is sent from terminal 2 of connector X2 on the Hot Air Control Module (N20) to the hot surface igniter (R20).

- ◇ The gas valve is energized allowing gas and air into the burner chamber to be ignited by the hot surface igniter.
- ◇ The Hot Air Burner Control Module (N20) senses at least 1.5 micro amps DC from the flame sensor (P1) at terminal 3 of connector X2 and sends a signal from terminal 2 of connector X1 to terminal 12 of connector X15 on the Control Board (A10)
 - The heat circuit will remain energized until the cabinet set temperature is reached as sensed at probe B6.
- e The steam circuit is energized.
 - 120 VAC is sent from terminal 4 of connector X12 on the Control Board (A10) to the coil of the Y3 solenoid allowing water to be thrown against the element until the bypass probe (B5) senses 183 degrees F.
 - The heat circuit will remain energized until the cabinet set temperature is reached
- f If the bypass probe (B5) drops below the set level the steam circuit will start again
- g When the condensate box is heated to 140 degrees F at the B3probe, 120 VAC is sent from terminal 5 of connector X12 to the condenser valve (Y1) until the temperature drops.
- h When the timer counts to 0 or the core temp probe (B10) reaches the set amount the cycle ends and the steam generator reverts to the standby temperature of 190-degree F.

PARTS LIST

LABEL	DESCRIPTION	PART NO.	LOCATION	LABEL	DESCRIPTION	PART NO.	LOCATION
-A10	CONTROL BOARD (SM 5010)	C5019100	3				
-A11	OPERATION BOARD (BM 5010)	C5019101	3	-U20	POWER BURNER ASSY, HOT AIR	-	5.D6
-A12	PICTO BOARD (OPTION)	C5019105	3.B1		FAN, BURNER, 120VAC	C5018007	
-A13	I.D. MODULE	C5019102	3.B8	-U22	POWER BURNER ASSY, HOT AIR.	-	7.D6
-A20	GAS BOARD (GM5010)	C5019103	4		FAN, BURNER, 120VAC	C5018007	
-B3	CONDENSOR PROBE	C5016007	3.B4	-W1	CABLE, 9 PIN COM.	300533	3.C3
-B4	STEAM GEN PROBE	C5016007	3.B3	-Y1	VALVE, CONDENSER, 120VAC	300455	3.E4
-B5	BYPASS PROBE	C5016007	3.B4		NOISE FILTER (RC)	300407	3.E4
-B6	OVEN PROBE	C5016006	3.B4	-Y10	VALVE ASSY, 2 WAY, 120VAC	300456	3.E
-B7.1	OVEN HI-TEMP THERMOSTAT	C5001041	5.B7		-Y2 VALVE, DEHUMID.	-	3.E
-B10	CORE TEMP. PROBE (KTM CTC)	C5013001	3.B4		-Y3 VALVE, GEN. FILL	-	3.E
-F1.1	FUSE, 3A	KE52936-6	2.B3		NOISE FILTER (RC)	-	3.E
-F2.1	FUSE, 1A	300418	3.E3		VALVE ASSY, 3 WAY, 120VAC(CLEANING OPTION)	300363	3
-F10.1, -F10.2	FUSE, 20A	300471	2.B5, 2.B8		-Y2 VALVE, DEHUMID.	-	3
-G1	POWER SUPPLY, 12VDC	300350	2.C3		-Y3 VALVE, GEN. FILL	-	3
-H5.1,-H5.2	OVEN LAMP	C5005043	3.E3, 3.E2		-Y21 VALVE, CLEAN/RINSE	-	3
-K0	RELAY, 120VAC	03524	5.E7		NOISE FILTER (RC)	-	
	SOCKET	300473		-Y20	PUMP, RINSING AGENT, 120VAC(CLEANING OPTION)	300352	3.E7
-M1, M2	MOTOR, CONVECTION	C50180221	2.E4, 2.E6	-Y22	PUMP, CLEANING AGENT, 120VAC(CLEANING OPTION)	300352	3.E8
-M3.1,-M3.2	COOLING FAN	C5018023	3.E1	-Y23	PUMP, CLEANING AGENT, 120VAC(CLEANING OPTION)	300352	3.E8
-N20	BURNER ASSY, HOT AIR	-	5.D3	-Z1,-Z2	LINE FILTER, 20A	300472	2.B1, 2.C2
	VALVE, GAS, 120VAC	C6016009					
	CONTROL, BURNER, 120VAC	C6016023					
-N22	BURNER ASSY, HOT AIR	-	6.D3				
	VALVE, GAS, 120VAC	C6016009					
	CONTROL, BURNER, 120VAC	C6016023					
-P1,-P3	FLAME SENSOR	C4018000	5.D3, 6.D3				
-R20,-R22	IGNITOR, HOT SURFACE	C4018001	5.E4, 6.E3				
-S1	SWITCH, CONTROL POWER	300278	2.A1				
-S2	PRESSURE SWITCH(PUMP)	C5013051	3.A5				
-S3	PRESSURE SWITCH(INJECTION)	C5009063	3.A6				
-S7	DOOR SWITCH	C5003075	3.A6				
-T1	TRANSFORMER, 120V/24V	300419	5.C2				
-T3	TRANSFORMER, 120V/24V	300419	6.C2				
-U10.1, -U10.2	AC DRIVE	300462	2.C5, 2.C7				

CONNECTION NUMBERING EXAMPLE

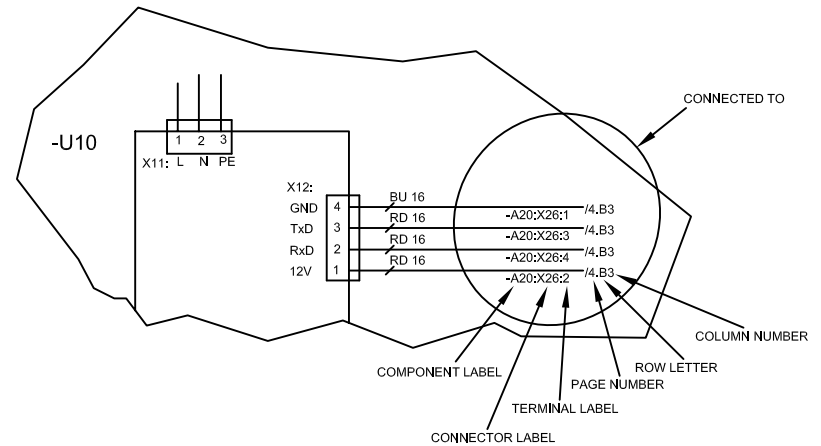

THIS DESIGN DESCRIBES A PROPRIETARY ITEM AND IS THE PROPERTY OF CLEVELAND RANGE. THIS DRAWING IS NOT TO BE COPIED OR USED WITHOUT THE APPROVAL OF CLEVELAND RANGE.

CLEVELAND RANGE, LLC
1333 East 179th St., Cleveland, Ohio 44110-2574

TITLE
WIRING DIAGRAM
OGS 20.20

VOLTAGE: 110-120
WATTAGE: -
CURRENT: 22.5A

DRAWN BY
DRL
DATE
12-02-05

DRAWING NO.
300498
SIZE
B

SHEET 1 OF 9

REV
D

WIRING DIAGRAM

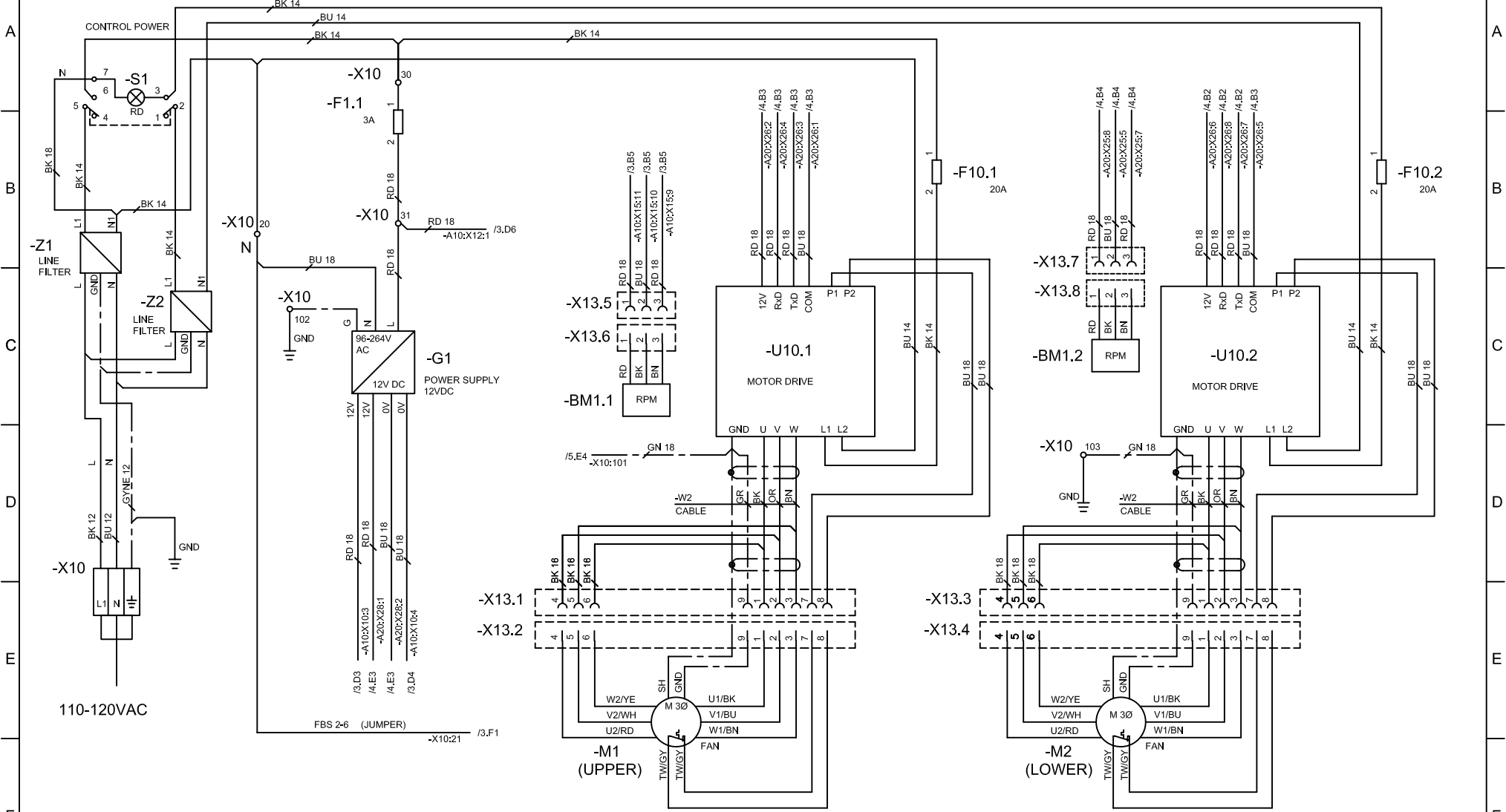

THIS DESIGN DESCRIBES A PROPRIETARY ITEM AND IS THE PROPERTY OF CLEVELAND RANGE.
THIS DRAWING IS NOT TO BE COPIED OR USED WITHOUT THE APPROVAL OF CLEVELAND RANGE.

CLEVELAND RANGE, LLC
1333 East 179th St., Cleveland, Ohio 44110-2574

TITLE
WIRING DIAGRAM
OGS 20.20

VOLTAGE: 110-120
WATTAGE: -
CURRENT: 22.5A

DRAWN BY
DRL

DATE
12-02-05

DRAWING NO.
300498

SIZE
B

SHEET 2 OF 9

REV
D

WIRING DIAGRAM

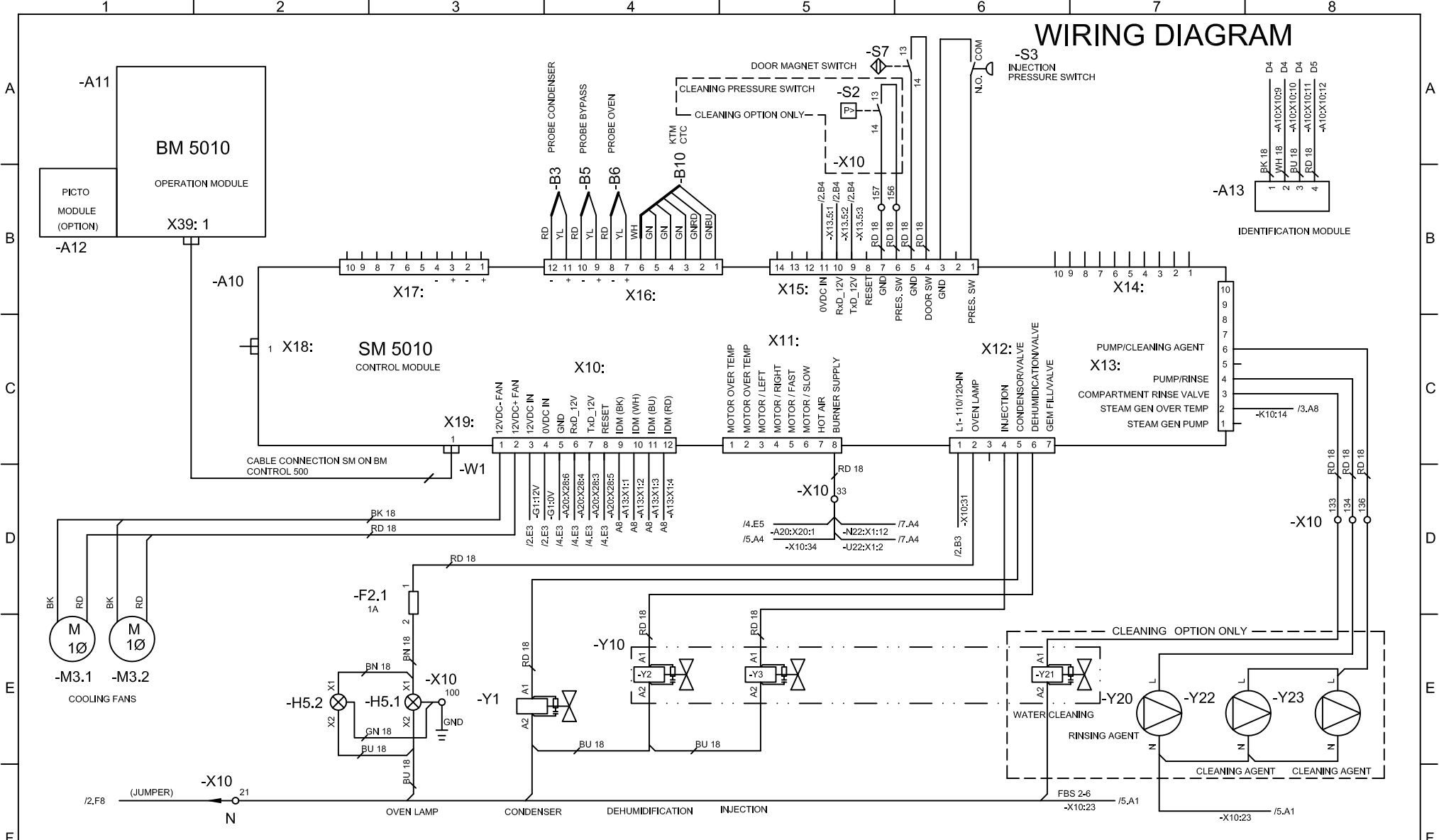

TITLE
WIRING DIAGRAM
OGS 20.20

VOLTAGE: 110-120
WATTAGE: -
CURRENT: 22.5A

DRAWN BY: DRL
DATE: 12-02-05

DRAWING NO.: 300498
SIZE: B
SHEET 3 OF 9

REV: D

WIRING DIAGRAM

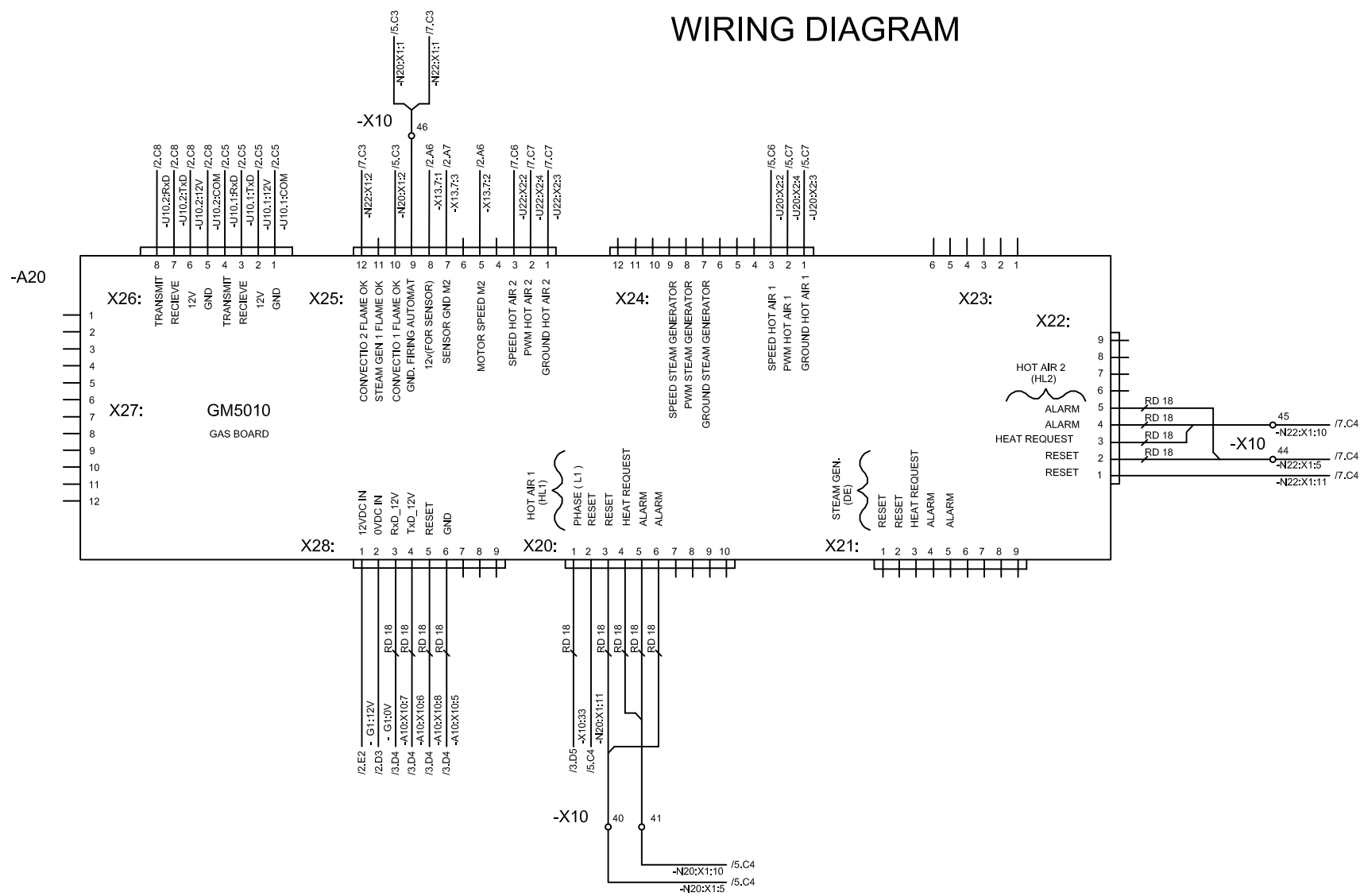

THIS DESIGN DESCRIBES A PROPRIETARY ITEM AND IS THE PROPERTY OF CLEVELAND RANGE. THIS DRAWING IS NOT TO BE COPIED OR USED WITHOUT THE APPROVAL OF CLEVELAND RANGE.	TITLE WIRING DIAGRAM OGS 20.20	VOLTAGE: 110-120 WATTAGE: - CURRENT: 22.5A	DRAWN BY: DRL DATE: 12-02-05	DRAWING NO.: 300498 SIZE: B	REV: D SHEET 4 OF 9
--------------------------------------------------------------------------------------------------------------------------------------------------------------------	---------------------------------------------	--------------------------------------------------	---------------------------------	--------------------------------	------------------------

CLEVELAND RANGE, LLC
1333 East 179th St., Cleveland, Ohio 44110-2574

WIRING DIAGRAM

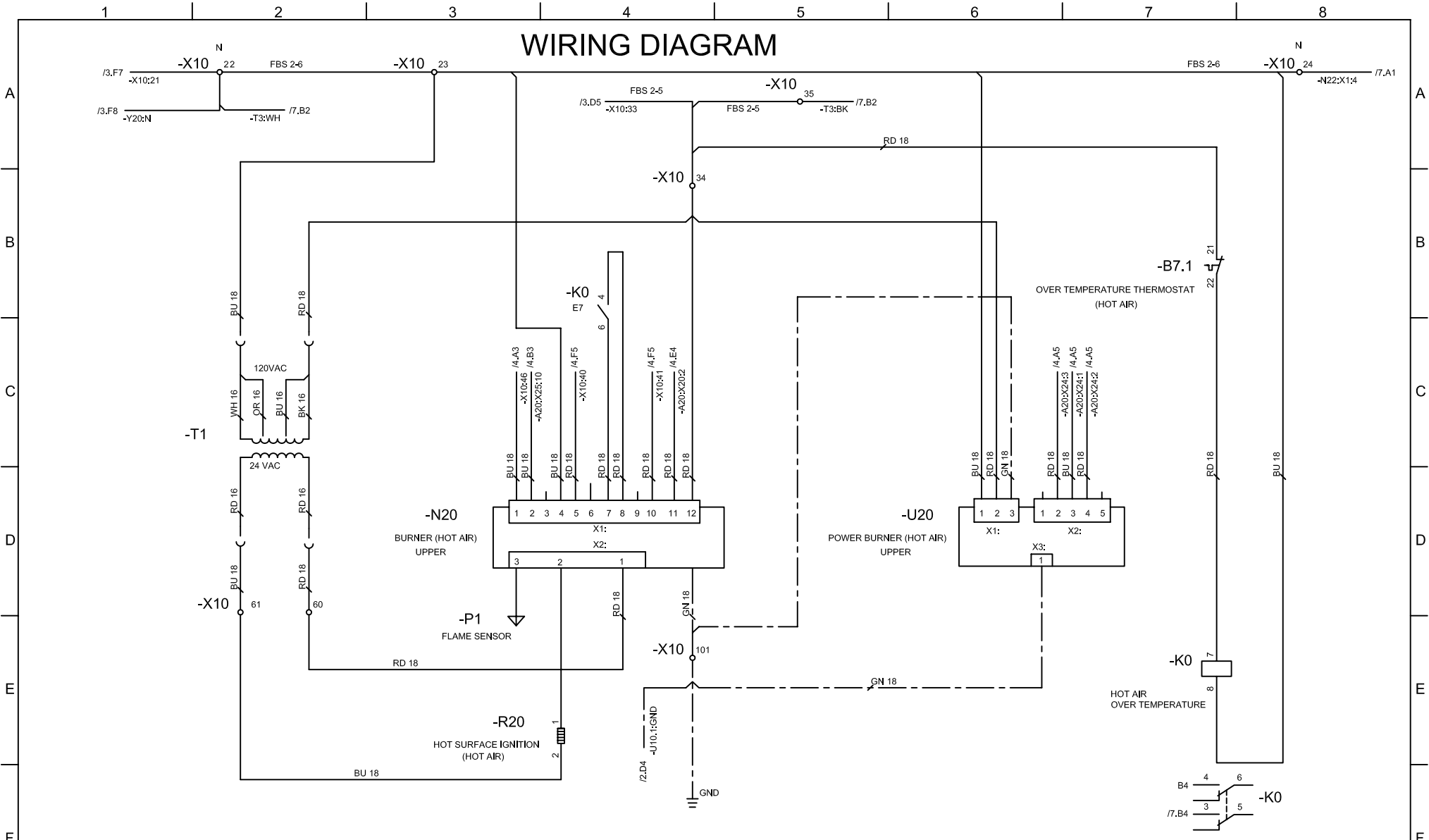

THIS DESIGN DESCRIBES A PROPRIETARY ITEM AND IS THE PROPERTY OF CLEVELAND RANGE. THIS DRAWING IS NOT TO BE COPIED OR USED WITHOUT THE APPROVAL OF CLEVELAND RANGE.	TITLE WIRING DIAGRAM OGS 20.20	VOLTAGE: 110-120 WATTAGE: - CURRENT: 22.5A	DRAWN BY DRL	DRAWING NO. 300498	REV D
CLEVELAND RANGE, LLC 1333 East 179th St., Cleveland, Ohio 44110-2574			DATE 12-02-05	SIZE B	SHEET 5 OF 9

WIRING DIAGRAM

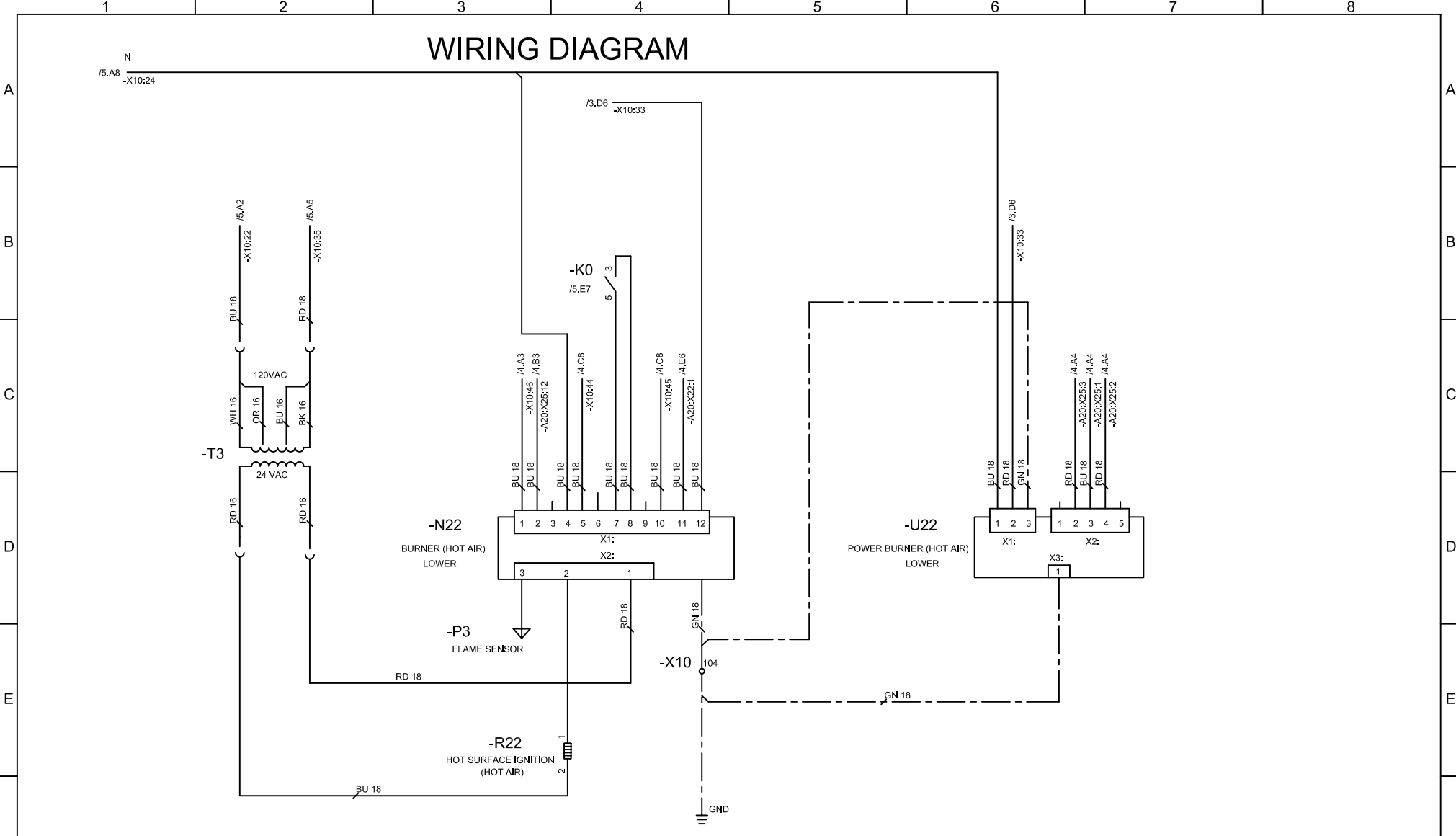

THIS DESIGN DESCRIBES A PROPRIETARY ITEM AND IS THE PROPERTY OF CLEVELAND RANGE.
THIS DRAWING IS NOT TO BE COPIED OR USED WITHOUT THE APPROVAL OF CLEVELAND RANGE.

CLEVELAND RANGE, LLC
1333 East 179th St., Cleveland, Ohio 44110-2574

TITLE
WIRING DIAGRAM
OGS 20.20

VOLTAGE: 110-120
WATTAGE: -
CURRENT: 22.5A

DRAWN BY
DRL

DATE
12-02-05

DRAWING NO.
300498

SIZE
B

REV
D

SHEET 6 OF 9

LADDER DIAGRAM

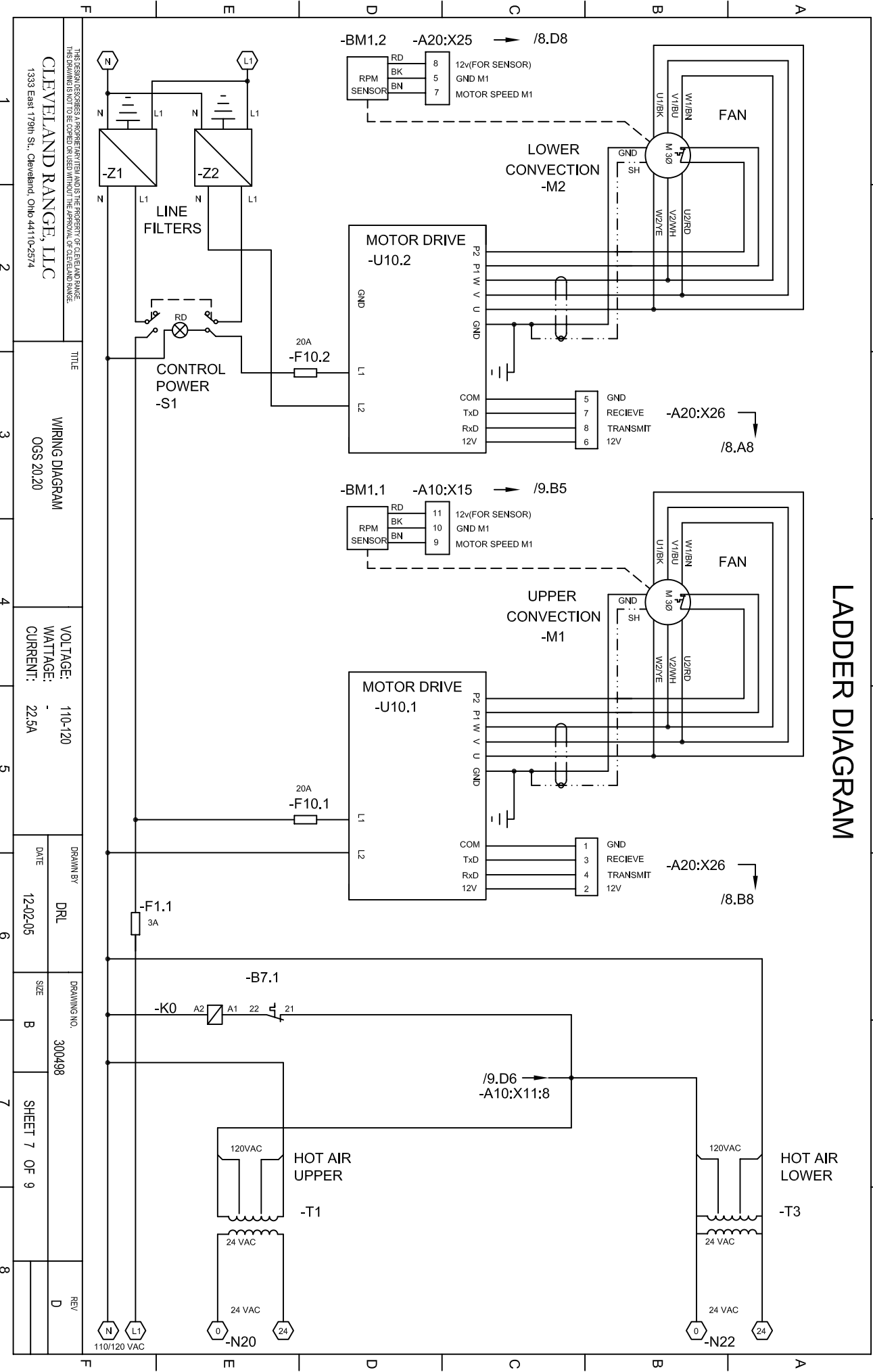

THE DESIGN DESCRIBES A REPRESENTATIVE UNIT AND IS THE PROPERTY OF CLEVELAND RANGE. THIS DRAWING IS NOT TO BE COPIED OR USED WITHOUT THE APPROVAL OF CLEVELAND RANGE.

CLEVELAND RANGE, LLC
1333 East 179th St., Cleveland, Ohio 44110-2574

TITLE
WIRING DIAGRAM
OCS 20.20

VOLTAGE: 110-120
WATTAGE: -
CURRENT: 22.5A

DRAWN BY: DRL
DATE: 12-02-05

DRAWING NO.: 300498
SIZE: B

SHEET 7 OF 9

REV: D

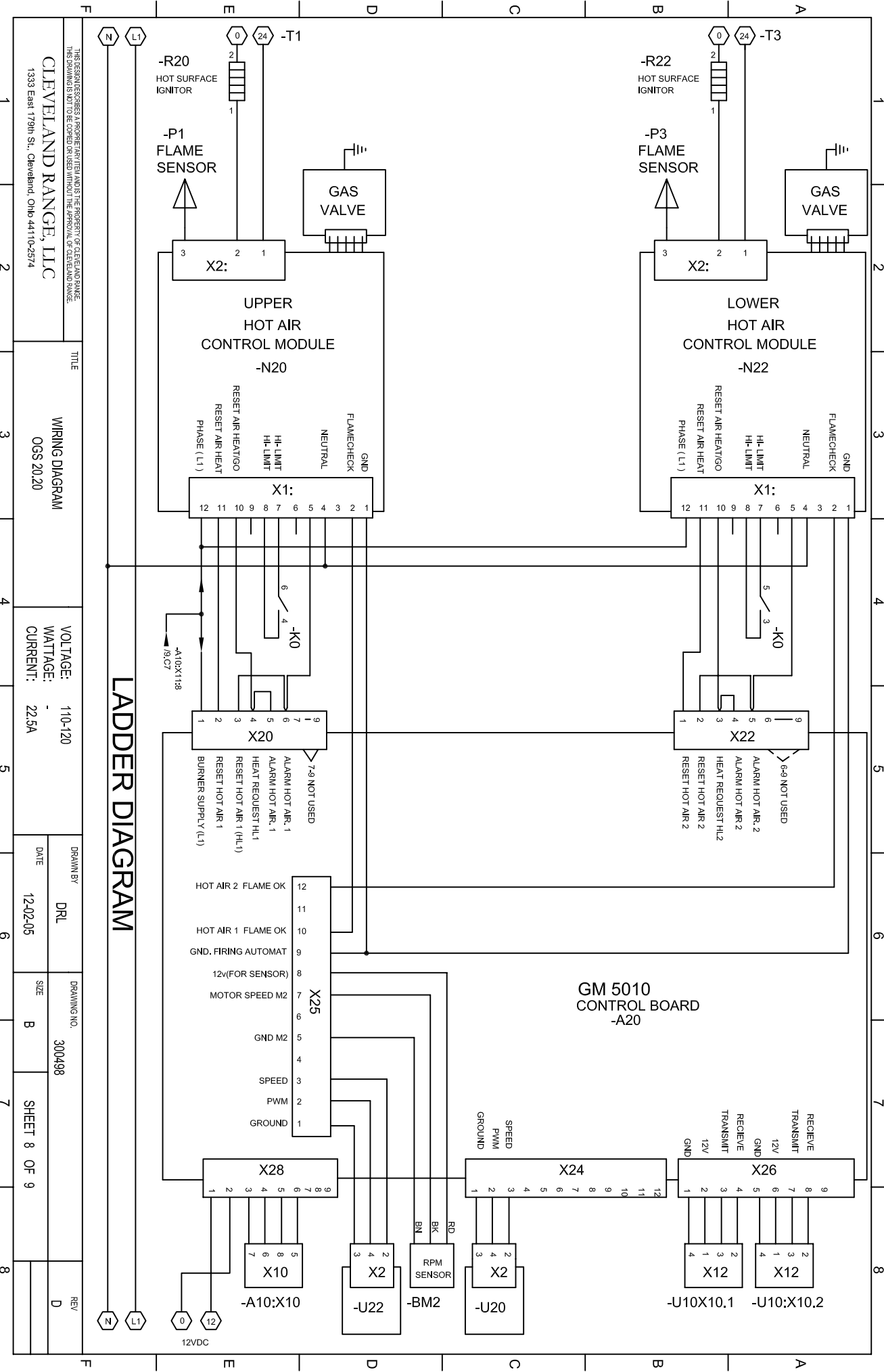

LADDER DIAGRAM

THE DESIGN DESCRIBES A PROPRIETARY DESIGN AND IS THE PROPERTY OF CLEVELAND RANGE. THIS DRAWING IS NOT TO BE COPIED OR USED WITHOUT THE APPROVAL OF CLEVELAND RANGE.	
CLEVELAND RANGE, LLC 1333 East 179th St., Cleveland, Ohio 44110-2574	TITLE WIRING DIAGRAM OCS 20.20
VOLTAGE: 110-120 WATTAGE: - CURRENT: 22.5A	DRAWN BY: DRL DATE: 12-02-05 DRAWING NO.: 300498 SIZE: B SHEET: 8 OF 9
	REV: D

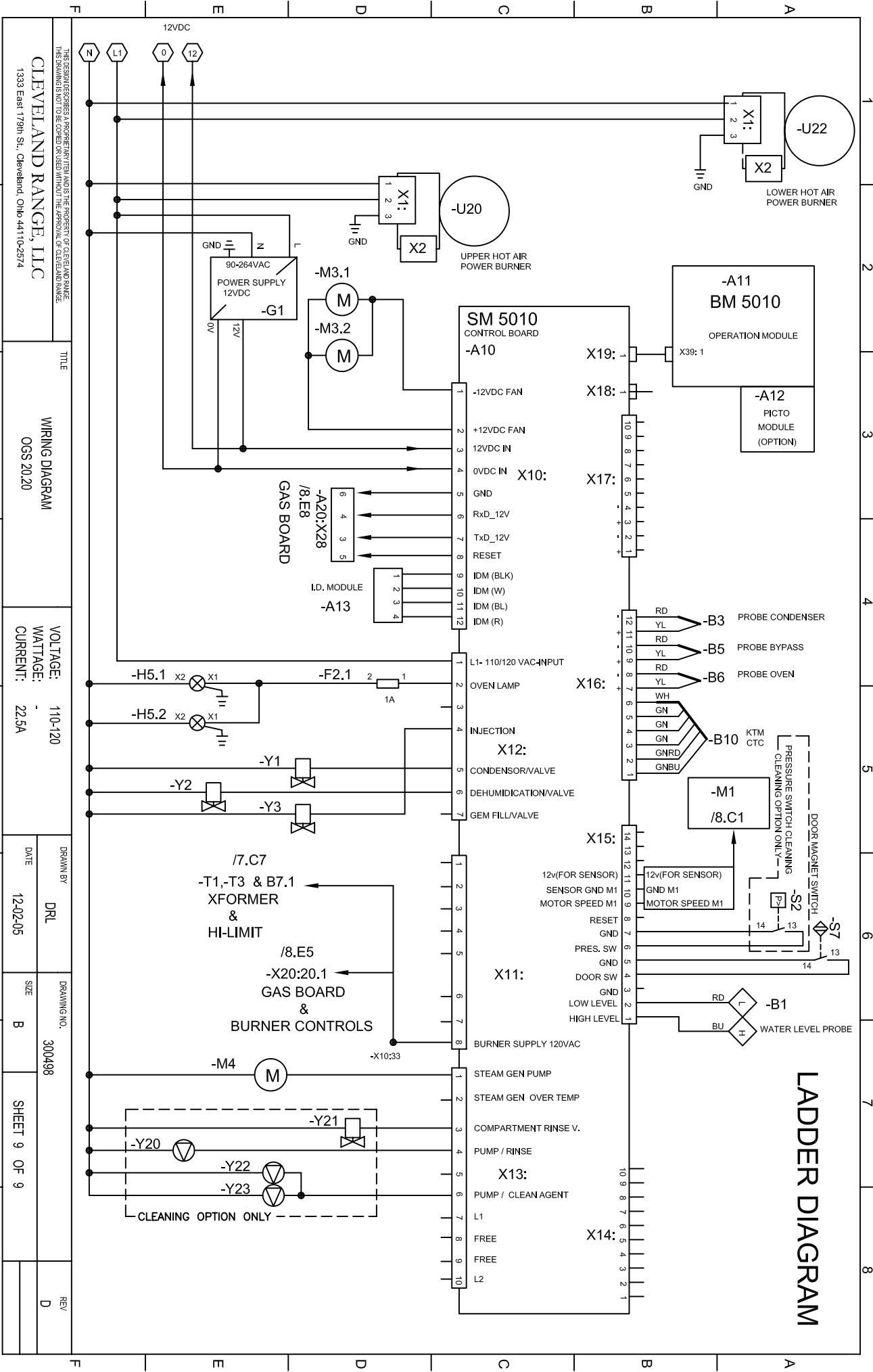

LADDER DIAGRAM

CLEVELAND RANGE, LLC
 1333 East 179th St., Cleveland, Ohio 44110-2574

TITLE
 WIRING DIAGRAM
 OCS 20.20

VOLTAGE:
 WATTAGE:
 CURRENT:
 110-120
 -
 22.5A

DATE
 12-02-05

SIZE
 B

SHEET 9 OF 9

REV
 D

DRAWN BY
 DRL

DRAWING NO.
 300498

Service Program

Information:

The unit's electronic control board offers the possibility of calling up various internal program parameters and operating states in order to detect possible faults.

Attention:

Any changes on the parameters in the Service program, other than the normal work adjustments (default values), could cause operation malfunctions.

Instructions: Calling up Customer Service program

1. Switch unit on with the ON/OFF key.
2. Press Service program key **1** on the back side of the control module **2**.
3. The display now shows the service number and the affiliated service value and a short explanation. The service number is selected on the display; this means that it is shown inverse.
4. By turning the selector dial, various service numbers can be called up.
5. With the Scroll key, the service number and the service value can be alternately shown (only with control and diagnostic values).
6. If the service value is selected (inverse), it can be adjusted with the selector dial. The changed service value is saved by the controls when the service number springs back via the Scroll left key.
7. The included service list gives comprehensive information about the meanings of the service numbers, the maximum and minimum adjustable values, the default values (standard setting) as well as the corresponding specifics.
8. Press the Service program key **1** or the START/STOP key in order to leave Customer Service.

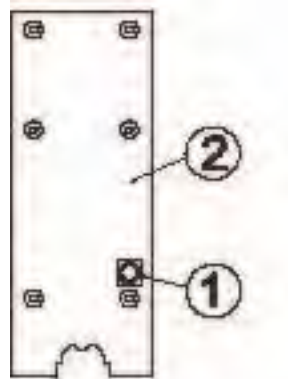

Advice:

The first letter of the service numbers indicates the following:

- ⌚ r-- = read value ↗ only for reading
- ⌚ c-- = control value ↗ for reading and writing (functions parameter)
- ⌚ d-- = diagnostic value ↗ for detecting errors and checking functions

Service No.:	Description	Connector	Pin	OEB	OES	OGB	OGS	Minimum Adjusted	Maximum Adjusted	Default Value	Specifics	Comments
r01	CTC 1 (Core Temp. Sensor 1)	X16	2+6	X	X	X	X				°C	Current temperature
r02	CTC 2 (Core Temp. Sensor2)	X16	3+6	X	X	X	X				°C	Current temperature
r03	CTC 3 (Core Temp. Sensor 3)	X16	4+6	X	X	X	X				°C	Current temperature
r04	CTC 4 (Core Temp. Sensor4)	X16	5+6	X	X	X	X				°C	Current temperature
r05	Oven-temp.	X16	7+8	X	X	X	X				°C	Current temperature
r06	Bypass-temp.	X16	9+10	X	X	X	X				°C	Current temperature
r07	Cond.-temp.	X16	11+12	X	X	X	X				°C	Current temperature
r08	Steamgen. Temp	X17	1+2	X		X					°C	Current temperature
r09	STB-temp. (=safety thermostat)	X17	3+4	X		X					°C	Current temperature
r10	Not Used											
r11	Not Used											
r12	Not Used											
r13	electronic-temp. (probe can be found on the electronic)			X	X	X	X				°C	Current temperature
r14	Ident gas					X	X			1		Saved in IDM
r15	Ident electric			X	X					1		Saved in IDM
r16	Not used											
r17	Not used											
r18	Cleaning Agent pressure	X15	6+7	X	X	X	X					Pressure switch S2 CONVOclean system 1 = pressure available
r19	Not used											
r20	Lower water level probe	X15	2	X		X						0 = Level not reached 1 = Level reached
r21	Upper water level probe	X15	1	X		X						0 = Level not reached 1 = Level reached
r22	motor thermo protection	X11	1+2	X	X	X	X					not in gas units
r23	Door switch	X15	4+5	X	X	X	X					0 = door open 1 = door closed
r24	FC1 Status											0= error free
r25	FC2 Status											0= error free
r26	Gas board Satus											0= error free
r27	Fan 1 speed											RPM
r28	Fan 2 speed											RPM
r29	Software operation board			X	X	X	X					
r30	Software control board			X	X	X	X					
r31	Software Gas board											
r32	Not used											

Service No.:	Description	Connector	Pin	OEB	OES	OGB	OGS	Minimum Adjusted	Maximum Adjusted	Default Value	Specifics	Comments
r33	Not used											
r34	Not used											
r35	Not used											
r36	Not used											
r37	Not used											
r38	Errors (last 10 error codes)			X	X	X	X					with Scroll key, call up the last 10 error codes
r39	Device no.			X	X	X	X					
r40	Part no.			X	X	X	X					
c01	Steam Generator standby temp.			X		X		50	95	88	°C	
c02	Condenser temp.			X	X	X	X	50	95	60	°C	
c03	Fan on cycle			X		X		1	20	2	s	Low temp fan on
c04	Fan off cycle			X		X		0	9	60	s	Low temp fan off
c05	Cont. steam			X	X	X	X	0	1	0		00 = regulated 01 = continuous steam
c06	Init			X	X	X	X	0	1	0		01 = All modules (BM, SM, KM) are initialized
c07	Humidity S (Steam)			X	X	X	X	50	95	87	°C	Bypass Probe Setting
c08	Humidity Super steam (combi)			X	X	X	X	50	96	90	°C	Bypass Probe Setting
c09	Humidity Quick (Steam > 212°F)			X	X	X	X	50	96	90	°C	Bypass Probe Setting
c10	Humidity Reg			X	X	X	X	5	20	12	s	Time for added steam
c11	Not Used							-	-	-		
c12	Bitfield1			X	X	X	X	-	-	-		Activate:300 Deactivate:305
c13	Bitfield2			X	X	X	X	-	-	-		Dummy Version=999
c14	Option1							-	-	-		Not used
c15	Option2							-	-	-		0=ID module is empty 1= ID module has recipes
c16	Restart time h			X	X	X	X	0	48	0	h	
c17	Restart time min			X	X	X	X	0	59	15	min	
c18	No. of ignition					X	X	1	5	2		
c19	PIN			X	X	X	X	0	999	001		Smart Key PIN #
c20	Sterilize			X	X	X	X	0	1	0		
c21	Shining from level			X	X	X	X	1	4	4		Convocare
c22	Cleaning Agent dosage			X	X	X	X	3	15	5	s	Convoclean
c23	Runtime right			X	X	X	X	0	250	120	s	only CONVOTHERM internal
c24	Runtime left			X	X	X	X	0	250	120	s	only CONVOTHERM internal
c25	Reverse wait time			X	X	X	X	0	250	15	s	only CONVOTHERM internal
c26	HL Nmin (HL=Convection)					X	X	1000	9000	****	rpm	Refer to Chapter 6.6
c27	HL N max (HL=Convection)					X	X	1000	9000	****	rpm	Refer to Chapter 6.6
c28	HL Nstart (HL=Convection)					X	X	1000	9000	****	rpm	Refer to Chapter 6.6

Service No.:	Description	Connector	Pin	OEB	OES	OGB	OGS	Minimum Adjusted	Maximum Adjusted	Default Value	Specifics	Comments
c29	HL-safety-Time					X	X	0	255	6	s	only CONVOTHERM internal
c30	HL-fore-run time					X	X	0	255	0	s	only CONVOTHERM internal
c31	HL1 actual rpm					X	X	-	-	-	rpm	only for reading value
c32	HL1 PWM (HL=Convection)					X	X	-	-	-	%	only CONVOTHERM internal
c33	HL1 (HL=Convection)					X	X	-	-	-		HFAR ^{*2}
c34	HL2 actual rpm					X	X	-	-	-		only for reading value
c35	HL2 PWM (HL=Convection)					X	X	-	-	-		only CONVOTHERM internal
c36	HL2 (HL=Convection)					X	X	-	-	-		HFAR ^{*2}
c37	DE Nmin blower (DE=Steam generator)					X		1000	9000	****	rpm	Refer to Chapter 6.6
c38	DE Nmax blower (DE=Steam generator)					X		1000	9000	****	rpm	Refer to Chapter 6.6
c39	DE Nstart blower (DE=steam generator)					X		1000	9000	****	rpm	Refer to Chapter 6.6
c40	DE-safety-Time (DE=Steam generator)					X		0	255	10	s	only CONVOTHERM internal
c41	DE-fore-run time (DE=Steam generator)					X		0	255	0	s	only CONVOTHERM internal
c42	DE actual rpm blower					X		-	-	-	rpm	only for reading value
c43	DE PWM (DE=Steam generator)					X		-	-	-	%	only CONVOTHERM internal
c44	DE (DE=Steam generator)					X		-	-	-		HFAR*2
d01	Delete Errors			X	X	X	X					*
d02	Key-lock (delete)			X	X	X	X					*
d03	Delete all recipese			X	X	X	X					*
d04	Selftest Operation Board			X	X	X	X					

* = activate with right Scroll key (shown inverse), then turn adjustable knob "1" and save by pressing and releasing the left Scroll key

*² = HFAR
- H = Heat demand (heat request)
- F = Valve open (flame ok)
- A = Alarm firing automatic
- R = Reset firing automatic

Testing the outputs

Information:

The electronic controls offer the possibility via the service numbers d04 - d24 to activate various outputs and various functions. Thereby checking the outputs and detecting any defects.

Safety:

When specific actuators (processes) are often tripped, one after the other, they can be destroyed!!!

Service No.:	Description	Contactors	Pin	OEB	OES	OGB	OGS	Comments
d04	Self testing of the control module			X	X	X	X	
d05	Testing steam generator 1	X12	4	X	X		X	In OES / OGS opens Y3
d06	Testing steam generator 2	X11	8	X				
d07	Testing convection heater 1	X12	3	X	X		X	
d08	Testing convection heater 2	X11	7	X	X			
d09	Testing the lamp	X12	2	X	X	X	X	
d10	Testing additional fan	X10	1+2	X	X	X	X	
d11	Testing main contactor	X13	2	X	X			
d12	Testing SV condenser cooling	X12	5	X	X	X	X	
d13	Testing SV St. gen. fill	X12	7	X		X		
d14	Testing St .gen. pump	X13	1	X		X		
d15	Testing SV demoisturizing	X12	6	X	X	X	X	
d16	Testing PFK-EOpt	X13	9+10	X	X			
d17	Testing motor fast right	X11	4+5	X	X	X	X	not in Gas units
d18	Testing motor slow right	X11	4+6	X	X	X	X	not in Gas units
d19	Testing motor fast left	X11	3+5	X	X	X	X	not in Gas units
d20	Testing motor slow left	X11	3+6	X	X	X	X	not in Gas units
d21	Testing water nozzles cleaning	X13	3	X	X	X	X	
d22	Testing nozzle rinsing cleaning	X13	4	X	X	X	X	
d23	Testing cleaner pump	X13	6	X	X	X	X	
d24	Testing ignition automat reset	X14	3				X	

Instruction:

1. The desired service point is called up from the selective service numbers with the selector dial.
2. Use this key Scroll right to change to service value.
3. Switch output on and off with selector dial.

Advice:

- When selecting D04, various functions and status displays light up in sequence, the display and the key frames. When a key is pressed, the position number is shown in the display.
- With d05 - d24 using the selector dial, the affiliated actuators (processes) can be activated for 5 Gas units seconds.

Error Codes

5. Troubleshooting list and error messages - Electronics

The last 10 error messages are stored in the service programme r38. In this service programme you can query the error messages with date and time (by pressing Mr. C) and delete them in the service programme d01.

OEB	OES	OGB	OGS	Error-message	Error description	possible cause or remedy
5.1 Error messages						
✓		✓		E01.0	Not enough water in the steam generator (water level could not be reached within 3 minutes)	<ul style="list-style-type: none"> • Tap closed • Soft water connection not connected to water supply • Dirt filter in the solenoid valve or in the mains water connection dirty • Water level sensor calcified (insulated) or defective • Through the use of non-original CONVOTHERM cleaners, foaming in the steam generator and insulating film on double level sensor • Filling gap in the steam generator is closed by calcium deposits • Water conductance too low through softening • Solenoid valve Y3 faulty • Injection nozzle in non-return device blocked • Steam generator calcified • Contact problems between steam generator and housing (earth connection) • Contact problems between water level sensor and terminal strip X15 of the control module
	✓		✓	E01.0	Not enough water (water pressure below 0.5 bar 3 seconds after valve switched through)	<ul style="list-style-type: none"> • Tap closed • Solenoid valve Y4 faulty • Pressure switch S1 defective • Dirt filter in the solenoid valve or in the mains water connection dirty • T-piece for pressure switch / manometer or injection nozzle in water supply blocked / dirty → clean with needle • Contact problems between pressure switch and terminal strip X15 of the control module • Appliance not connected to soft water and therefore inlet calcified



OEB	OES	OGB	OGS	Error-message	Error description	possible cause or remedy
✓	✓	✓	✓	E02.0	Excessive temperature in the wiring space At a temperature > 45°C the auxiliary fan is switched on. Error threshold at 80°C Fan runs permanently in the OGB and OGS.	<ul style="list-style-type: none"> • Vent slits blocked by an inadequate space between appliance and wall • Air supply blocked • Minimum distance to heat sources not observed • + and - of the 12 V auxiliary fan reversed
✓	✓			E03.0-0-0	Fan malfunction (Excessive temperature in the motor winding) → Thermoprotection contact has triggered (not with the OES 6.06)	<ul style="list-style-type: none"> • Fan motor has excessive temperature in the winding <ol style="list-style-type: none"> a) One phase is missing from the power connection b) Fan motor defective c) One phase is not connected through from the contactor d) Miniature fuse F10 (6.3 A or 10 A for floor models) has tripped e) Thermoprotection contact in the motor winding (bimetal) defective or interrupted
		✓	✓	E03.1-xxx-yyy	Temperature of the fan motor 1 (top) too high	<ul style="list-style-type: none"> • Fan motor has excessive temperature in the winding (over 165°C) <ol style="list-style-type: none"> a) One phase is missing from the power connection b) Fan motor defective c) One phase is not connected through from the contactor d) Miniature fuse F10 (6.3 A or 10 A for floor models) has tripped e) Thermoprotection contact in the motor winding (bimetal) defective or interrupted • For an explanation of the parameter xxx-yyy-zzz see the end of 5.1 → page 9
		✓	✓	E03.2-xxx-yyy	The speed sensor of the fan motor 1 (top) is no longer reporting a speed	<ul style="list-style-type: none"> • Motor speed not reached • Speed sensor on the motor defective • Mains voltage supply has faults, possibly also undervoltage • Frequency converter defective • FC dirty • For an explanation of the parameter xxx-yyy-zzz see the end of 5.1 → page 9
		✓	✓	E03.4-xxx-yyy	Error frequency converter 1 (for top motor)	<ul style="list-style-type: none"> • Mains voltage supply has faults, possibly also undervoltage • Frequency converter defective • FC dirty • Wiring space temp. too high (but E02 is not being displayed yet → check wiring space cooling)



OEB	OES	OGB	OGS	Error-message	Error description	possible cause or remedy
						<ul style="list-style-type: none"> • Check operation of auxiliary fan • Fan blocked or wrong motor • Motor defective • FC defective • For an explanation of the parameter xxx-yyy-zzz see the end of 5.1 → page 9
		✓	✓	E03.8-xxx-yyy	Temperature of the fan motor 2 (bottom) too high	<ul style="list-style-type: none"> • Fan motor has excessive temperature in the winding (over 165°C) <ul style="list-style-type: none"> a) One phase is missing from the power connection b) Fan motor defective c) One phase is not connected through from the contactor d) Miniature fuse F10 (6.3 A or 10 A for floor models) has tripped e) Thermoprotection contact in the motor winding (bimetal) defective or interrupted • For an explanation of the parameter xxx-yyy-zzz see the end of 5.1 → page 9
		✓	✓	E03.16-xxx-yyy	The speed sensor of the fan motor 2 (bottom) is no longer reporting a speed	<ul style="list-style-type: none"> • Motor speed not reached • Speed sensor on the motor defective • Mains voltage supply has faults, possibly also undervoltage • Frequency converter defective • FC dirty • For an explanation of the parameter xxx-yyy-zzz see the end of 5.1 → page 9
		✓	✓	E03.32-xxx-yyy	Error frequency converter 2 (for top motor)	<ul style="list-style-type: none"> • Mains voltage supply has faults, possibly also undervoltage • Frequency converter defective • FC dirty • Wiring space temp. too high (but E02 is not being displayed yet → Check wiring space cooling) • Check operation of auxiliary fan • Fan blocked or wrong motor • Motor defective • FC defective • For an explanation of the parameter xxx-yyy-zzz see the end of 5.1 → page 9
		✓	✓	E03.128	Communication failure between CM and GM or between GM and FC	<ul style="list-style-type: none"> • Check cable connection GM too FC • FC defective • GM defective • For an explanation of the parameter xxx-yyy-zzz see the end of 5.1 → page 9



OEB	OES	OGB	OGS	Error-message	Error description	possible cause or remedy
		✓	✓	E03.zzz -xxx-yyy	Other error variants	<ul style="list-style-type: none"> For an explanation of the parameter xxx-yyy-zzz see the end of 5.1 → page 9
		✓	✓	E03.1	Fan malfunction (Excessive temperature in the motor winding) → Thermoprotection contact has triggered	<ul style="list-style-type: none"> Fan motor has excessive temperature in the winding (over 165°C) <ul style="list-style-type: none"> a) One phase is missing from the power connection b) Fan motor defective c) One phase is not connected through from the contactor d) Miniature fuse F10 (6.3 A or 10 A for floor models) has tripped e) Thermoprotection contact in the motor winding (bimetal) defective or interrupted Burner speed (fan) not reached Motor speed not reached Speed sensor on the motor defective Frequency converter defective (with single phase) Frequency converter (FC) (=all 1 NPE appliances) <ul style="list-style-type: none"> - Old hardware FC (above all appliances before 1.10.04 without gas module!) - Replace FC (5014001) (current version HW 26.11.04 / SW 1.2!!) - Update CM and OM software to the current version (Install 3.14 or above)! Wiring space temp. too high (but E02 is not being displayed yet → Check wiring space cooling)
✓	✓	✓	✓	E04.0	Auxiliary fan fault Motor current too high etc.: threshold of 1.5A (V1-V2)	<ul style="list-style-type: none"> Auxiliary fan defective Auxiliary fan wiring interrupted Auxiliary fan blocked
		✓	✓	E05.0	No gas (after 2 ignition attempts no confirmed gas flame)	<ul style="list-style-type: none"> No gas or fault in burner system Glow igniter defective (measure current approx. 1.5A) Glow insert displaced in metal housing (replace glow igniter) Ionisation electrode defective <ul style="list-style-type: none"> - Short circuit monitoring electrode (observe ignition of the burner in the start phase; if flame was present: monitoring circuit is the cause!) Watch out for short circuit between cable and housing in particular! - Burner stocking braid has a short circuit to earth to the ionisation electrode - Ionisation electrode cable is resting on earth (in the burner or on motor cover) Air in gas pipe Gas tap closed



OEB	OES	OGB	OGS	Error-message	Error description	possible cause or remedy
						<ul style="list-style-type: none"> • Input undervoltage (< 195 V) (Gerät über Kabeltrommel angeschlossen) • OGS/OGB 10.20/12.20/20.20 (and 20.10 only SG) starts poorly/does not start after glow electrode replacement <ul style="list-style-type: none"> - Wrong glow igniter fitted: short instead of long; correct is 4018001 = long (Wrong is 4018002 = short) • STL has triggered (Test passage) • Burner fan is not running (visual inspection or in speed actual value in the service programmes) • Interruption in monitoring electrode wiring
		✓	✓	E05.1	No gas	<ul style="list-style-type: none"> • B7.1 Safety temperature limiter for hot air has triggered (Test passage) • No gas at the burner HA1 (Hot air1) • In addition same causes possible as with E05.0
		✓		E05.2	No gas	<ul style="list-style-type: none"> • B7.2 Safety temperature limiter for steam generator has triggered (Test passage) • No gas at the burner SG (steam generator) • In addition same causes possible as with E05.0
		✓	✓	E05.3	No gas	<ul style="list-style-type: none"> • No gas at the burner HA2 (Hot air2) • In addition same causes possible as with E05.0
		✓	✓	E05.4-1	No gas	<ul style="list-style-type: none"> • Start speed at the burner HA1 not reached → PWM signal interrupted
		✓	✓	E05.4-2	No gas	<ul style="list-style-type: none"> • Start speed at the burner HA1 not reached → Possibly voltage supply disturbed
		✓		E05.5-1	No gas	<ul style="list-style-type: none"> • Start speed at the burner SG not reached → PWM signal interrupted
		✓		E05.5-2	No gas	<ul style="list-style-type: none"> • Start speed at the burner SG not reached → Possibly voltage supply disturbed
		✓	✓	E05.6-1	No gas (only 20.10 / 20.20)	<ul style="list-style-type: none"> • Start speed at the burner HA2 not reached → PWM signal interrupted
		✓	✓	E05.6-2	No gas (only 20.10 / 20.20)	<ul style="list-style-type: none"> • Start speed at the burner HA2 not reached → Possibly voltage supply disturbed
		✓	✓	E05.7-1	No gas	<ul style="list-style-type: none"> • Full load speed at the burner HA1 not reached → PWM signal interrupted
		✓	✓	E05.7-2	No gas	<ul style="list-style-type: none"> • Full load speed at the burner HA1 not reached → Possibly voltage supply disturbed
		✓		E05.8-1	No gas	<ul style="list-style-type: none"> • Full load speed at the burner SG not reached → PWM signal interrupted



OEB	OES	OGB	OGS	Error-message	Error description	possible cause or remedy
		✓		E05.8-2	No gas	<ul style="list-style-type: none"> Full load speed at the burner SG not reached → Possibly voltage supply disturbed
		✓	✓	E05.9-1	No gas (only 20.10 / 20.20)	<ul style="list-style-type: none"> Full load speed at the burner HA2 not reached → PWM signal interrupted
		✓	✓	E05.9-2	No gas (only 20.10 / 20.20)	<ul style="list-style-type: none"> Full load speed at the burner HA2 not reached → Possibly voltage supply disturbed
		✓	✓	E05.10	No gas (as of Software Version 4.15) If within 20 sec. no „Flame OK-“ or „Alarm-Signal“	<ul style="list-style-type: none"> Interruption of Flame OK- or Alarm Signal between Flame controller – control module HA1. Check connection between FA and CM / GM: CM (Control Module): on OGS 6.10 to OGS 12.20: X14:1/2 and X15:12 (for units without GM) GM (Gas Module): Plug X20:5/6 and X25:10 FA (Flame controller): Terminals 1, 2, 5
		✓	✓	E05.11	No gas (as of Software Version 4.15) If within 20 sec. no „Flame OK-“ or „Alarm-Signal“	<ul style="list-style-type: none"> Interruption of Flame OK- or Alarm Signal between Flame controller – control module SG. Check connection between FA and GM: GM (Gas Module): Plug X21:4/5 and X25:11 FA (Flame controller): Terminals 1, 2, 5
		✓	✓	E05.12	No gas (as of Software Version 4.15) If within 20 sec. no „Flame OK-“ or „Alarm-Signal“	<ul style="list-style-type: none"> Interruption of Flame OK- or Alarm Signal between Flame controller – control module HA2. Check connection between FA and GM: GM (Gas Module): Plug X22:4/5 and X25:12 FA (Flame controller): Terminals 1, 2, 5
✓	✓	✓	✓	E11.0	Oven sensor (B6 thermoelement) excessive temperature (Temperature on the sensor >300°C)	<ul style="list-style-type: none"> Hot air contactors do not switch off (burnt together) Motor not operating (e.g. because of 2 defective miniature fuses F10, not with the 6.06 as F10 protects the CM).
✓		✓		E13.0	Steam generator (B4 thermoelement) Excessive temperature (if temperature measured in the SG >120°C)	<ul style="list-style-type: none"> Foaming in the steam generator when cooking (due to e.g. wrong, non-original CONVOTHERM cleaning agents) Calcification of the steam generator Boiling dry of the immersion heaters due to double level sensor's short circuit to earth
✓	✓	✓	✓	E15.0	Condenser sensor (B3- thermoelement) excessive temperature (if temperature in the condenser measured > 100°C)	<ul style="list-style-type: none"> Water reservoir in the condenser too hot: <ol style="list-style-type: none"> Water tap closed Appliance connected to hot water Solenoid valve “condenser cooling” defective Coil from the solenoid “condenser cooling” defective Inlet filter in the solenoid valve contaminated Quenching nozzle in the condenser/siphon blocked



OEB	OES	OGB	OGS	Error-message	Error description	possible cause or remedy
	✓			E16.0	Demoisturisation flap operating fault (only 6.06)	<ul style="list-style-type: none"> Demoisturisation flap faulty <ol style="list-style-type: none"> Stiff Motor contact Motor defective Flap blocked Cable defects (contact / motor) Micro switch not correct adjusted
✓	✓	✓	✓	E21.0	Oven sensor (B6-thermoelement) interruption	<ul style="list-style-type: none"> Sensor wiring interrupted (plug X16 of the control module) Oven sensor (B6) interrupted (defective)
✓	✓	✓	✓	E22.0	Core temperature sensor (B10- thermoelement) interruption (if more than 2 measuring points are interrupted)	<ul style="list-style-type: none"> Sensor wiring interrupted (plug X16 of the control module) CTS sensor (B10) interrupted (defective)
✓		✓		E23.0	Steam generator (B4 thermoelement) interruption	<ul style="list-style-type: none"> Sensor wiring interrupted (plug X17 of the control module) Steam generator (B4) interrupted (defective)
✓	✓	✓	✓	E24.0	Bypass sensor (B5-thermoelement) interruption (not with the 6.06)	<ul style="list-style-type: none"> Sensor wiring interrupted (plug X16 of the control module) Bypass sensor (B5) interrupted (defective)
✓	✓	✓	✓	E25.0	Condenser sensor (B3- thermoelement) interruption	<ul style="list-style-type: none"> Sensor wiring interrupted (plug X16 of the control module) Condenser sensor (B3) interrupted (defective)
✓		✓		E26.0	Safety temperature limiter (B8-thermoelement) interruption	<ul style="list-style-type: none"> Sensor wiring interrupted (plug X17 of the control module) CTS (SG) sensor (B8) interrupted (defective)
✓		✓		E27.0	STL (B8-thermoelement) excessive temperature (STL measures a temp. >130°C in the SG when SG heaters switched on)	<ul style="list-style-type: none"> Foaming in the steam generator when cooking (due to e.g. wrong, non-original CONVOTHERM cleaning agents) Calcification of the steam generator Boiling dry of the immersion heaters due to double level sensor's short circuit to earth
✓	✓	✓	✓	E29.0	Short circuit to earth of a thermoelement	<ul style="list-style-type: none"> A thermoelement sensor has contact with appliance housing Connection between sensor wire and sensor housing ➔ Test individual sensors for short circuit to earth (beginning with CTS)
✓		✓		E33.0	Steam generator operating fault (No	<ul style="list-style-type: none"> Immersion heater defective



OEB	OES	OGB	OGS	Error-message	Error description	possible cause or remedy
					temperature increase in the SG within 3 mins. by >5°C on the B3 sensor)	<ul style="list-style-type: none"> • Heater contactor defective • Calcified B3 sensor
✓		✓		E34.0	SG pump fault Pump does not start (double level sensor does not reach lower level within 20 secs.)	<ul style="list-style-type: none"> • Pump defective (M4) • Pump blocked / contaminated • Water level sensor has short circuit to earth due to calcification • Filling gap of the area touching the water is calcified together with the double level sensor
✓	✓	✓	✓	E80.0	ID error (identity error)	<ul style="list-style-type: none"> • It cannot be determined whether the appliance is gas or electric, therefore all outputs are switched off. • IDM module defective
✓	✓	✓	✓	E81.0	Programme memory error	<ul style="list-style-type: none"> • If the working parameters of a multi-step programme are not between min. and max. values • After saving a cooking plan in the cookbook the temperature display is changed from °C to °Fahrenheit
✓	✓	✓	✓	E82.0	WP error (working parameter error)	<ul style="list-style-type: none"> • If the working parameters of a cooking programme are not between min. and max. values • Invalid data stored in the cookbook
✓	✓	✓	✓	E83.0	Alg. error (invalid cooking algorithm)	<ul style="list-style-type: none"> • Incompatible software between operating module and control module
✓	✓	✓	✓	E89.0	External memory module defective	<ul style="list-style-type: none"> • The external memory module (IDM module) in the cable harness is defective • Contact problems of the X10 plug
✓	✓	✓	✓	E95.0	Software error	<ul style="list-style-type: none"> • Communication problems between software and hardware • Different hardware and software versions which cannot work together
✓	✓	✓	✓	E96.0 E96.1 E96.2	Connection faulty between control module and operating module	<ul style="list-style-type: none"> • Interface cable between control module and operating module interrupted • Plug on the control module or operating module loose • Communication between CM and OM disturbed briefly → Re-start appliance
✓	✓	✓	✓	Not enough cleaner pressure	Too little flow pressure on the pressure switch S2 (after 40 sec. still below 0.1 bar)	<ul style="list-style-type: none"> • Cleaner level/nozzle flushing agent level in the canister too low • Piping in the pump box is kinked • Suction hose not in the cleaner fluid / nozzle flushing agent



OEB	OES	OGB	OGS	Error-message	Error description	possible cause or remedy
						<ul style="list-style-type: none"> • Rotor nozzle worn or defective -> loses too much fluid in the middle • Cleaner nozzle behind suction plate is loose or missing • Piping in the pump box leaking • Cleaner pump without supply voltage • Cleaner pump overheated • Cleaner pump defective
✓	✓	✓	✓	Fatal IDM error	No viable record in the IDM module and control module	<ul style="list-style-type: none"> • When switching on and booting the appliance controller finds no viable record either in the control module itself or in the IDM <ul style="list-style-type: none"> a) due to overvoltage record in the IDM was destroyed b) IDM module defective c) contact problems of the X10 plug
✓	✓	✓	✓	IDM error	IDM module error	<ul style="list-style-type: none"> • When switching on and booting the appliance controller finds no viable record in the IDM. If there is a viable record in the CM itself, there is an attempt to transfer this to the IDM. If this works, the error disappears, if not, the error always appears briefly when switching on → fit new IDM or reprogram it with "IDM-Tool.exe"

■ Error variants to error 03.zzz-xxx-yyy

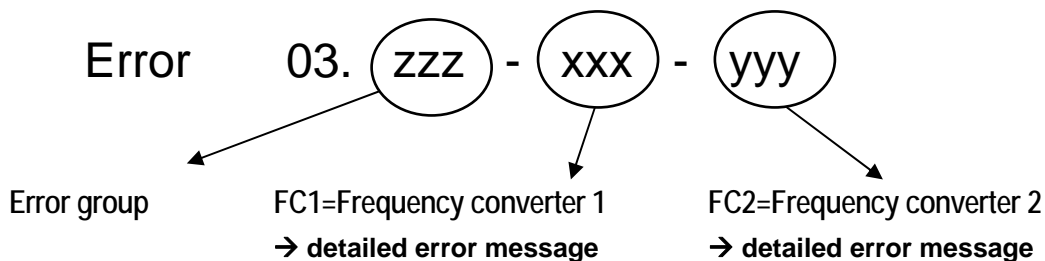

Error numbers "zzz", "xxx" and "yyy" are binary coded, i.e. the error numbers shown on the display must be converted with the use of the following tables.

Variants for zzz

128	64	32	16	8	4	2	1
Error on the gas module	not used	Error on the frequency converter 2	Speed sensor of the fan motor 2 is no longer reporting a speed	Temperature of the fan motor 2 too high	Error on the frequency converter 1	Speed sensor of the fan motor 1 is no longer reporting a speed	Temperature of the fan motor 1 too high



Error 03.zzz → Examples:

Error 03.128 → 128 = Error on the gas module

Error 03. 5 → 5 = 4 + 1 → Error on the frequency converter 1 and motor temperature too high

Variants for xxx (for FC1) and yyy (for FC2)

128	64	32	16	8	4	2	1
Motor was stopped (because of an error)	Inertia of motor and fan too great	Overcurrent recognition on the FC	(FC output current stays for a long time above the rated current) e.g. in the event of smaller	Motor temperature → Motor PTC not connected	Electronic temperature of the FC	temporary error on the FC	Error in the power module of the FC

Error 03.zzz - xxx - yyy → Examples:

Error 03. 5 - 36 - 0 →
 5 = Error on the frequency converter 1 and motor temperature too high
 36 = 32 + 4 → Overcurrent recognition on the FC1+ Electronic temperature of the FC1-
 0 = FC2 is OK

Error 03. 32 - 0 - 144 →
 32 = Error on the frequency converter 2 -
 0 = FU1 is OK -
 144 = 128 + 16 → Motor was stopped because of error + FC output current remains for a long time above the rated current