

Classic Steamer Pressure Steamers

Installation, Operation & Maintenance Manual

This manual is updated as new information and models are released. Visit our website for the latest manual.

MODELS:

PGM, PEM,
PSM, PDM,
PDL-2/3

For your future reference.

Model # _____

Serial # _____



**Read the manual thoroughly.
Improper installation, operation or
maintenance can cause property
damage, injury or death.**

Part # - KE004044 B

Safety Notices

As you work on Cleveland Range equipment, be sure to pay close attention to the safety notices in this handbook. Disregarding the notices may lead to serious injury and/or damage to the equipment.

Throughout this handbook, you will see the following types of safety notices:

DANGER

Text in a Danger box alerts you to an imminent personal injury situation. Be sure to read the Danger statement before proceeding, and work carefully.

Warning

Text in a Warning box alerts you to a potential personal injury situation. Be sure to read the Warning statement before proceeding, and work carefully.

Caution

Text in a Caution box alerts you to a situation in which you could damage the equipment. Be sure to read the Caution statement before proceeding, and work carefully.

Procedural Notices

As you work on Cleveland Range equipment, be sure to read the procedural notices in this handbook. These notices supply helpful information which may assist you as you work.

Throughout this handbook, you will see the following types of procedural notices:

Important

Text in an Important box provides you with information that may help you perform a procedure more efficiently. Disregarding this information will not cause damage or injury, but it may slow you down as you work.

NOTE: Text set off as a Note provides you with simple, but useful, extra information about the procedure you are performing.

Read These Before Proceeding

Warning

Improper installation, adjustment, alteration, service or maintenance can cause property damage, injury or death. Read the installation, operating and maintenance instructions thoroughly before installing or servicing this equipment.

DANGER

ELECTRIC SHOCK HAZARD

DEATH, INJURY, or EQUIPMENT DAMAGE can result from touching any component inside this appliance when the power is connected.

Whenever possible disconnect the power while installing, servicing, or testing. When installation, service, or tests require power to be connected; use extreme caution and every possible precaution and safety measure while installing, servicing, or testing this appliance.

Operational Safety

Minimum safety policies and procedures for operating one or more Cleveland Range appliances:

1. Do not store anything on top of the appliance.
2. KEEP THE APPLIANCE AREA FREE AND CLEAR OF COMBUSTIBLES.
3. Proper air supply for ventilation is REQUIRED for and CRITICAL to safe, efficient operation of this appliance.
4. Place non-slip draining anti-fatigue mats rated for use in wet, greasy, or dry work areas on the floor in front of the appliance and other locations as needed. Obtain the best mats for your needs from your local supplier.
5. Wear BOOTS appropriate to the work area to help protect feet, and to help prevent slips and falls.
6. Allow only qualified Cleveland Range authorized service representatives to service the appliance.
7. Use only factory authorized repair parts.
 - A. Maintain written records of appliance service, maintenance, and repair. See Section 4.

ALL SERVICE MUST BE PERFORMED BY A QUALIFIED CLEVELAND RANGE AUTHORIZED TECHNICIAN

KEEP THIS MANUAL FOR REFERENCE

This manual may be subject to new technical developments, modifications, and unforeseen errors.

DO NOT INSTALL OR OPERATE OR ATTEMPT TO INSTALL OR OPERATE THIS APPLIANCE OR ANY ACCESSORIES WITHOUT READING COMPLETELY AND FULLY UNDERSTANDING THIS MANUAL.

Cleveland Range appliances are intended for other than household use.

Warning

For Your Safety

Do not store or use gasoline or other flammable vapors or liquids in the vicinity of this or any other appliance.

Table of Contents

Section 1 General Information

Product Information	5
Model Numbers and Serial Numbers.....	5
Product Information Plate.....	5
Electrical Diagram Location.....	5

Section 2 Installation

Laws, Codes, and Regulations	7
Installation Details	7
Gas Leak Instructions – Gas Units.....	7
Installation Requirements	7
Free Start-Up Program.....	8

Section 3 Operation

Start-Up and Preheat	9
Cooking Operation.....	10
Boiler Shutdown.....	11
Cooking Guidelines.....	11
Meat	11
Vegetable Steaming.....	11
Desserts	11
Other Dishes.....	11
Vegetable Pressure Steam Cooking Chart	12

Section 4 Maintenance

General Information	13
Maintenance and Service Records	13
Preventive Maintenance.....	13
Inspection Requirements.....	13
Daily Maintenance	14
Boiler Blowdown	14
Cleaning Compartments.....	14
Exterior Care.....	14
Weekly Maintenance.....	14
Descaling Procedure	14
DISSOLVE Descaling Liquid.....	15
Overview of Pump Descaling Procedures.....	15
Equipment Setup	16
Descaling.....	16
Flushing	17
Takedown and Return to Service	17

**Section 5
Troubleshooting**

Troubleshooting Guide..... 19
Troubleshooting Notes 20

**Section 6
Service Record**

Section 1

General Information

Product Information

This manual covers the operation of Cleveland Range Pressure Steamers, Series PGM, PEM, PSM, PDM and PDL-2/3, and the standard features and options available on these models.

- Other than the selection of options, there are presently no significant design, parts, or operating differences among appliances with these model numbers.
- Instructions for the operation of boiler bases are separate. For details on installation, refer to 260BKT.
- For further information, contact your Cleveland Range sales representative or Cleveland Range.

MODEL NUMBERS AND SERIAL NUMBERS

1. Cleveland Range, LLC assigns two product identification numbers to each appliance: a model number and a serial number.
2. Please provide this information when you contact Cleveland Range or a qualified Cleveland Range authorized service representative:
 - Model Number _____
(Write the Model Number of your appliance here.)
 - Serial Number _____
(Write the Serial Number of your appliance here.)

PRODUCT INFORMATION PLATE

The Product Information Plate is located on the inside of the cabinet door of the boiler base.

ELECTRICAL DIAGRAM LOCATION

The Electrical Diagram is located on the inside of the cabinet door of the boiler base.

Section 2

Installation

Laws, Codes, and Regulations

The installation of this appliance must conform with:

- A. The National Fuel Gas Code, ANSI Z223.1/NFPA 54 (latest edition), or the Natural Gas and Propane Installation Code CSA B149.1, or local codes, as applicable.
- B. The National Electrical Code, ANSI/NFPA 70 (latest edition), or the Canadian Electrical Code, CSA C22.2, or local codes, as applicable.
 - When installed, the appliance must be electrically grounded in accordance with the above.
 - NOTE: This appliance is not GFI (GFCI) compatible.
- C. The Food Code (latest edition) of the Food and Drug Administration (FDA).

This equipment is to be installed to comply with the applicable federal, state, or local plumbing codes.

This equipment is used with a Boiler as defined by Section IV of the ASME Boiler and Pressure Vessel Code (latest edition). In addition to compliance with all applicable codes and regulations, compliance with all laws regarding Boilers and Pressure Vessels, including, but not limited to, operator training, and obtaining permits and licenses is required before starting the Boiler.

Instructions must be read in their entirety before starting this appliance.

Installation must comply with all local fire and health codes.

Warning

Do not connect the drain connection to any drain material that cannot sustain 180°F.

Using drain material that cannot withstand 180°F can result in injury, equipment damage, and property damage.

NOTE: The use of good quality feed water as listed in the Cleveland Range Limited Warranty is the responsibility of the Owner-User. See Water Quality Recommendations as listed in the Cleveland Range Limited Warranty. THE USE OF POOR QUALITY FEED WATER WILL VOID EQUIPMENT WARRANTIES.

Installation Details

For details on installation of Classic Steamer Pressure Steamers, refer to 260BKT.

GAS LEAK INSTRUCTIONS – GAS UNITS

Important

- Post instructions to be followed if the user smells gas.
- Display the instructions in a prominent location.
- Obtain the instructions from the local gas supplier.

INSTALLATION REQUIREMENTS

Warning

- This appliance is not GFI (GFCI) compatible.
- Do not use a GFI (GFCI) circuit.
- Using a GFI (GFCI) circuit can result in injury, equipment damage, and property damage.

WATER — The quality of water you put into the steam generator is important. Poor quality water will create steam generator problems.

Water used in the steam generator is no longer just plain water. Water has many natural impurities. These impurities are called Total Dissolved Solids (TDS). These TDS include calcium, iron, copper, and other minerals that will collect in the steam generator during operation. Water quality varies from area to area. If the water impurities are not filtered out or cleaned out with a regular preventive maintenance program, your steam generator could deteriorate and develop holes.

CHLORIDES are another chemical in water creating problems in all steam generators. When the generator separates the steam from the water it also carries the chloride with it. These chlorides begin to eat away the inside of the generator and follow the steam into the compartments, causing a rusting action called oxidation.

DO NOT install a water conditioner on your steamer. A softener uses salt to improve water quality. Poor softener operation can add chlorides to the steam generator.

A CARBON OR CHARCOAL FILTER must be installed on the incoming water line to the steamer if the chlorine is over 30 parts per million. These filters will remove most of the chlorine.

The **WATER QUALITY REQUIREMENTS** for your STEAMER are as follows:

Total Dissolved Solids	less than 60 parts per million
Total Alkalinity	less than 20 parts per million
Silica	less than 13 parts per million
Chloride	less than 30 parts per million
ph Factor	greater than 7.5

DRAIN LINE CONNECTION

A clean drain line connection is important. Check daily. If the drain line is not large enough, not open at the end, or does not have a gravity flow, pressure water will back up into the cooking compartments, which could cause serious injury.

An open and free flowing drain line IS REQUIRED for the proper cooking performance of a CONVECTION STEAMER. It helps create a swirling action around the products being cooked. This movement of hot steam around the product is your CONVECTION STEAM COOKING.

DO NOT INSTALL OVER A FLOOR DRAIN. If it becomes an absolute must, use an 18" stainless steel or aluminum pan. Turn it over and cut a notch in the side wall to fit over the drain line. Place the pan directly over the drain opening. **DO NOT SEAL TO THE FLOOR.** The steam from the drain line will collect on the under side and condense into the drain opening.

DO NOT INSTALL GAS UNITS ON FLAMMABLE FLOORS OR NEAR WALLS. A flammable floor or wall is any material such as wood, linoleum, or vinyl that is easily ignitable and burns rapidly.

Free Start-Up Program

Performance Check-Out: Contact your Cleveland Range maintenance and repair center for your Performance Check-Out before starting your new Cleveland Range Steamer.

The Performance Check-Out includes:

- Inspection of the Installation
- Review of Cleaning Procedures
- Review of Maintenance Procedures
- Start of Warranty Protection

Equipment Demonstration: After your Performance Check-Out, contact your Cleveland Range sales representative for your free Equipment Demonstration.

The Equipment Demonstration includes:

- Proper Operation
- Optimized Use
- Care, Cleaning, and Maintenance

To arrange for your free Start-Up Program appointment consult your Customer Service Directory or call Cleveland Range at:

216-481-4900

OR

1-800-338-2204

Ask your sales representative for more information about uses for your new appliance.

DANGER

Without power, there is NO safe method of operation of this appliance.

DO NOT ATTEMPT TO START OR OPERATE this appliance during a power failure. DEATH, INJURY, AND/OR EQUIPMENT DAMAGE may result.

Section 3 Operation

⚠ DANGER

BURN and SCALD HAZARD

Exposure to steam, condensate, and hot surfaces can cause death, burns, and scalds.

To help avoid injury:

- Do NOT breathe steam or condensate.
- Stand on the hinge side and away from the appliance and slowly open the cooking compartment door.
- Open the door slightly to allow steam, condensate, and heat to vent before looking or reaching into the cooking compartment.
- Always wear DRY heatproof gloves when reaching into the cooking compartment or handling hot items. Wet or damp gloves conduct heat and may cause burns when handling hot items.

Failure to follow these precautions can result in death, burns, and scalds.

Units with Gas Boilers only:

⚠ DANGER

DO NOT TRY TO LIGHT BURNERS WITH A FLAME.

This appliance has an electronic ignition system, which automatically lights burners, senses flame, and controls gas flow. Burners cannot be lit with a flame.

DEATH, INJURY, OR EQUIPMENT DAMAGE may result.

⚠ DANGER

DEATH, INJURY OR EQUIPMENT DAMAGE may result from an improperly adjusted gas control and ignition system. Do not alter any adjustments on the electronic control or gas valve.

If adjustment is required, contact an authorized service center. Cleveland Range is in no way responsible for the operation or safety of this equipment if the controller, valve, or igniter probe are adjusted by anyone other than a qualified Cleveland Range authorized service representative.

⚠ Caution

Press switches and keys with fingertips only.

Injury and equipment damage can result from pressing switches and keys with anything else.

Operation of the Cleveland Range Pressure Steamer is very easy. Each operator should read and understand the following procedures to effectively start, operate, and shut down the steamer each day. The owner(s) and operator(s) of this equipment should be aware that live steam could cause serious injuries. Pay particular attention to the WARNINGS in this text. These instructions are to be retained by the owner(s) and operator(s) for future reference.

NOTE: These instructions pertain to pressure steamers equipped with a steam generator (boiler). For pressure steamers direct-connected to a remote (in-house) steam source, disregard those instructions which pertain solely to a self-contained boiler.

Start-Up and Preheat

⚠ Warning

Do not attempt to start or operate the Pressure Steamers during a power failure. Critical safety circuits are not energized, and serious injury to personnel or damage to equipment may result.



Boiler Controls

1. Start the steam supply. The steam supply is either a steam generator boiler built into the base unit or an external steam supply.

For units without a built-in boiler, refer to the start-up procedures for the external steam supply and be sure it is running properly. As soon as the pressure gauge on the front console registers 10 psi, steamer preheating may begin. Skip the remainder of step 1, and begin step 2.

For units with a built-in boiler, fill the boiler with water and start the steam generator as described in step a. through d. below.

- a. Press the ON end of the POWER on-off rocker switch located next to the steam pressure gauge. The red indicator light in the POWER rocker switch turns on and the steam generator begins to fill with water, which takes about 5 minutes.
 - b. When the water level in the steam generator reaches a safe operating level, the amber light in the STEAM switch turns on. Whenever the amber light is on, the heaters, steam supply, or burners are off, and no steam is being generated. The energy source (electric, gas, etc.) cannot be activated until the boiler contains sufficient water, indicated by the amber light.
 - c. Press the STEAM (amber colored) momentary switch to produce steam in the boiler. This activates the energy source (electric heaters, gas burners, or steam solenoid valve) and the amber light turns off. The STEAM switch must be pressed to restart the steamer after it is shut off for any reason (including a brief power interruption). No attempt should be made to operate the equipment during a power failure.
NOTE: For steamers with built-in gas-fired boilers: If the burners fail to ignite in four seconds, a safety circuit energizes the system. In this event toggle the POWER rocker switch to the OFF position and back to the ON position. The amber light in the STEAM momentary switch lights. Wait five minutes, and then press the STEAM momentary switch to start the burner ignition cycle once again.
 - d. About 15 minutes after starting the boiler in step c, the steam pressure gauge on the unit base should register 10 psi.
2. To preheat, close and latch the door securely. Turn the bar handle clockwise until the gasket just touches the compartment face.
 3. Start the steam supply by pulling the steam valve handle out. The handle is located to the immediate left of the door latch. Set the time for 5 minutes. The standard mechanical timer must be turned past 10 minutes to wind the spring. Then set the timer for 5 minutes. This is not necessary with the optional automatic timer. At the start, the compartment thermostatic traps will release air and wet steam for about two minutes, then shut off. Throughout the preheating or cooking cycles, the traps will open and close periodically, venting cooler steam and condensate.

4. Seal the compartment door by turning the bar handle clockwise just until steam leakage stops. DO NOT OVERTIGHTEN.
5. At the completion of the 5-minute preheating cycle, the timer's bell will ring. If fitted with an optional automatic timer, turning the knob to OFF will stop the bell. Push the steam valve handle in slowly, all the way. This shuts off the steam supply and also depressurizes and drains the compartment, which takes about 2 minutes.

NOTE: The automatic timer shuts off the steam automatically; the mechanical timer does not. Neither timer depressurizes and drains the compartment.

⚠ Warning

Wait at least two minutes for the compartment(s) to depressurize and drain before opening the compartment door.

6. To open the compartment door, turn the bar handle counter-clockwise. Do not attempt to disengage the door arm latch. When the compartment has depressurized and drained completely, the door will open slightly and come to rest against the door arm latch.

⚠ Warning

If at this point the door does not open partially by itself, it is a sign that the drain line is blocked. Do not attempt to open the door. Retighten the bar handle and then call a serviceman to open the door and unblock the drain line.

Cooking Operation

Check the cooking compartment to ensure it is warm. If it is cool, perform the steps for preheating.

Place the pan(s) of food into the cooking compartment by sliding the pan(s) into the slide rack. For optimum steam heat transfer, and therefore, a higher quality food product, use shallow, perforated, uncovered pans. If pans must be covered, use only stainless steel pan lids designed for use with the pan racks. Do not cover pans with aluminum foil or plastic wrap, as they may fall out of the pan and clog the drain. A clogged drain may cause an accumulation of hot water in the cooking compartment which could cause injury when the door is opened.

Boiler Shutdown

The red-lighted power switch must be shut off for 3 minutes a minimum of once every 8 hours to automatically drain highly mineralized water from the boiler, which reduces the formation of scale. See Daily Maintenance in the *Maintenance* section.

Cooking Guidelines

Steam cooking is an excellent way to prepare countless foods. With large or small quantities you will find steam cooking to be efficient, economical, fast and convenient. Foods can never burn — pans will never boil over — there is no heavy lifting of water pots — no scouring of containers — no waiting for boiling to start.

MEAT

Steam provides an even, intense and penetrating heat, which, because of its nature, cooks meat with minimal shrinkage. The meat is tender, moist and flavorful. Stews, pot roasts, hams and corned beef are excellent when steam cooked.

Chickens, turkeys and other poultry items are steamed without any shrinkage. The meat is tender and juicy. The birds may be steamed whole, cut in half, or in pieces. Chicken pieces may be partially steam cooked and then finished in the skillet or fryer. The result is flavor and succulence.

Steam tenderizes stewing fowl. It produces excellent meat for sandwiches and salads, both moist and savory, and easily sliced.

VEGETABLE STEAMING

Vegetables should be crisp and fresh before cooking. They should be cooked al dente. This prevents over cooking, the most prevalent mistake in pressure steam cooking. The natural characteristic flavors are present when vegetables are cooked in this manner.

Cut vegetables to the same size pieces to assure uniform results. Vegetables should be washed before cooking. Removing tough stems and skins will shorten cooking times and improve results. Vegetables may be lightly seasoned before or after steaming. In general, use perforated pans for fastest results.

Frozen vegetables, in general, should be defrosted before pressure-cooking. Three vegetables can be pressure steamed from the frozen stage: carrots, peas and whole kernel corn.

Volume cooking of potatoes and other tuberous vegetables is an excellent application. 100 pounds of potatoes per compartment can be cooked in 40 minutes. Other tuberous vegetables include: sweet potatoes, carrots, beets, onions, kohlrabi, turnips and parsnips. Winter squash and cabbage can also be cooked in volume.

DESSERTS

Many kinds of cornstarch pudding and custard desserts are prepared by steaming. Any dish cooked in the double boiler may be successfully steamed. The steamer is ideal for heating or scalding milk, because the danger of scorching or burning is absent.

Fruit desserts such as steamed “baked” apples are another suggestion. Core the apples and arrange on a shallow pan. Fill the cored space with cinnamon and sugar, then steam. If desired, the apples may be finished by browning under the broiler. Applesauce is another steam application, as are stewed pears or peaches. Dried fruits, properly marinated, turn out beautifully.

OTHER DISHES

Under this heading comes a host of dishes not otherwise classified.

Cereals, eggs, noodles, spaghetti, rice, macaroni and dumplings, with variations of each, are just a few.

Cooked, frozen convenience foods, such as beef stroganoff, pot roast and noodles, chicken fricassee and rice, stuffed cabbage rolls, need only be brought up to serving temperature and then transferred from the pack directly onto the serving plate. The time required to heat these convenience foods is 5-10 minutes for the individual portion pack and 20-35 minutes for the 5-pound multi-serving pack. The cover of the packs should be perforated with a sharp fork to let the steam escape.

The disposable aluminum foil pans should be placed on a perforated stainless steel pan for support when steaming or carrying the hot product. Cover the pan with a stainless lid if a cover is not provided. Do not use plastic wrap or aluminum foil as a cover in the pressure steamer.

Vegetable Pressure Steam Cooking Chart

The cooking time for vegetables have wide limits due to several factors. Young or new vegetables cook in less time than the older ones. Freshly picked vegetables cook faster than those long stored. Different species of the same foods cook in varying time limits. The size of the vegetable or pieces affects the speed of cooking. The type of container also influences the length of the cooking period. Shallow pans are faster than deep ones, the perforated types are faster than the solid.

Suggested Time in Minutes	
Fresh Vegetables	
Asparagus	7-8
Beans, Green	8-10
Bean, Lima	15-17
Beets	20-40
Broccoli Spears	8-10
Brussels Sprouts	10-15
Cabbage, wedges	8-10
Carrots	8-10
Cauliflower	8-10
Corn	5-8
Onions	10-12
Parsnips	12-15
Peas	5-8
Peppers, stuffed	20-30
Potatoes, white	20-40
Potatoes, sweet	25-40
Rutabaga, cubed	8-10
Spinach	3-6
Squash, summer, cut	5-7
Squash, winter, half	10-15
Turnips, cubed	12-15
Frozen Vegetables	
Beans, Green, regular	4-5
Beans, Lima	4-5
Broccoli Spears	5-6
*Brussels Sprouts	2-3
Carrots, diced	5-6
Cauliflower	3-4
Corn, cut (Kernel)	3-4
Peas	4-5
*Mixed Vegetables	5-6

* Defrosted Only

Section 4

Maintenance

General Information

Follow the maintenance instructions and schedules to help keep the appliance working properly.

Increase the frequency of maintenance as needed depending on use and water quality.

Contact your qualified Cleveland Range authorized service agency or Cleveland Range for more information about maintenance scheduling, products, and services.

Maintenance and Service Records

1. Make a file just for maintenance records.
2. Keep a written record of daily, weekly, monthly, and yearly maintenance, descaling, service, and repair. Each record must include at least:
 - a. The date of the maintenance, descaling, service, or repair.
 - b. A description of the service, maintenance, or repair performed.
 - c. Copies of purchase order(s) and invoice(s) for repair parts and service, descaling, maintenance, and repair. Include part numbers, if applicable.
 - d. The name and signature of the person performing the service, maintenance, or repair.

Preventive Maintenance

PREVENTIVE MAINTENANCE is the key to keeping your equipment in top condition. There are certain cleaning procedures that should be performed on a regular schedule.

Daily

1. Using a NON-CHLORINE DETERGENT.
 - a. Wipe out the interior of the compartments.
 - b. Wipe the face of the compartments.
 - c. Rinse the pan slides.
 - d. When the steamer is not cooking, leave the door open resting against the door latch.
 - e. Wipe down the gaskets to prevent sticking.
 - f. Drain line openings inside and outside the cooker.

Weekly

1. Check the door gasket for wear and reverse it when needed.
2. Pour down the back of each compartment drain a liquid chemical descaler.

Monthly

1. Every 3 to 4 months the generator should be opened and checked for mineral buildup or chloride corrosion. Check for generator scale buildup greater than the thickness of a business card or if the scale is beginning to peel off in layers. If either one of these conditions is present, the generator needs to be chemically descaled by your CLEVELAND AUTHORIZED SERVICE AGENCY.
2. Check, clean, or replace the screen in the incoming water strainer.
3. Check and tighten all door fasteners.
4. Check all steam, water, and electrical connections. Contact your authorized Cleveland Range service agency to make the necessary repairs.

INSPECTION REQUIREMENTS

1. Inspect more frequently in areas where the water conditions do not meet our Water Quality Requirements.
2. A generator with a Reverse Osmosis (R.O.) System should be opened every six months to:
 - a. Check to make sure R.O. is working properly.
 - b. Change the boiler gasket for liability reasons.

Daily Maintenance

The Cleveland Pressure Steamer must be cleaned regularly to maintain its fast, efficient cooking performance, and to ensure its continued safe, reliable operation.

BOILER BLOWDOWN

The boiler must be drained (Blowdown) after a maximum of 8 hours of use. If the boiler feedwater contains more than 60 parts per million of total dissolved solids, the boiler must have a Blowdown more often, the frequency depending upon the mineral content of the feedwater. Blowdown means the boiler must be drained under pressure.

The boiler blowdown is performed by simply shutting off the steamer's red lighted power switch while the boiler is at normal 10 psi operating pressure. When the bottom of the power rocker switch is pressed, its red light goes out, and the drain valve automatically opens, draining the boiler. Automatically timed drain water condenser will flush the drain for 3 minutes then shut off. After 3 minutes the steamer is ready to be restarted.

When steam is produced, the water in the boiler is being distilled. During this process, the minerals that come into the boiler with the water remain in the boiler as the water boils away as steam. When allowed to accumulate, the water becomes highly mineralized, which results in erratic operation, lime build-up, corrosion and premature electric heater failures. In some cases, complete boiler replacement becomes necessary, which is extremely expensive. By draining the boiler under pressure, most sediment present will be flushed down the drain.

CLEANING COMPARTMENTS

With the steamer off, open the cooking compartment doors and allow the steamer to cool before cleaning the cooking compartments and their components.

At the end of each day's operation, wash the pan slides door gaskets and compartment interiors with mild detergent and warm water, either by hand or in a dishwasher. Rinse thoroughly with clear water. Rinse water should drain freely through the compartment drain openings. If it does not, the drain must be cleaned before using the steamer.

NOTE: To prolong door gasket life, always leave compartment door ajar when not in use.

EXTERIOR CARE

Allow steamer to cool before washing. Use the same cleaners and cleaning procedures as for other kitchen surfaces of stainless steel and aluminum. Mild soapy water, with a clear water rinse, is recommended. **DO NOT ALLOW WATER TO RUN INTO ELECTRICAL CONTROLS.** Always turn off equipment power before using water to wash equipment. Do not hose down the steamer!

Weekly Maintenance

The steamer is equipped with a drain in the back of the cooking compartment. No compartment should be operated without the drain screen in place. This screen prevents large food particles from entering and possibly plugging the drain line. Any restriction of the drain line may cause a slight buildup of back pressure in the compartment, resulting in steam leaks around the door gasket. It also may adversely affect the convection action of the steam in the compartment, which is critical to optimum performance. Pouring USDA approved drain cleaner through the compartment drains once a week will help to ensure an open drain. An auger or "snake" may be safely used to clear obstructions in the compartment drains. Do not use a power auger, as damage to the plastic drain system will result.

Descaling Procedure

Descaling is the most important maintenance you can perform on a steam cooker, and is required by the Cleveland Range warranty.

Cleveland Range has developed the Descaling Pump System for owners of the Classic Series Convection Steamers, Pressure Steamers and SteamPro/Convection Pro series steam cookers.

The Descaling Pump System circulates DISSOLVE descaling liquid through the boiler of the steamer. Recirculating the descaling liquid provides a faster and more thorough cleaning process than the conventional soaking process.

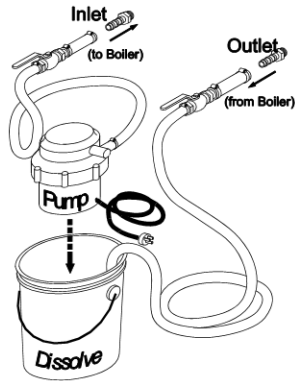

Descaling Pump System

The Pump System provides a fast, highly efficient way to descale Cleveland Steam Cookers. The descaling pump kit includes a temporary hand-hole plate that is equipped with two descaling ports, one for the inlet and one for the outlet. This is to be used only for the pump kit and replaced at the end of the procedure.

The Descaling Pump System consists of a submersible pump, a 5-gallon reservoir pail, hand-hole plate with ports, the feed and drain hoses, and the temporary hose couplings necessary to connect the system to the Classic Series Cleveland Steamers.

Important

Only service technicians authorized by Cleveland Range should perform the descaling procedure. Read and be familiar with the procedure before starting. Follow the procedure exactly as given.

DISSOLVE DESCALING LIQUID

Use only Cleveland Range DISSOLVE descaling product. Five gallons of descaling liquid will be needed during this procedure. Avoid unnecessary contact with the descaling product; read and follow safety precautions on the container label.



DISSOLVE Order Quantities		
Container Size	Qty	Part No.
1-gallon bottles	6	106174
5-gallon pail	1	1061741
5-gallon pails	12	10617411
5-gallon pails	24	10617412

OVERVIEW OF PUMP DESCALING PROCEDURES

Below is a summary of the descaling procedure using the Pump System. The detailed procedure is given on the following pages.

Descaling should be done as required by your maintenance schedule. The process takes about an hour and a half to complete.

PART A – EQUIPMENT SETUP

- Turn off the steamer to drain the boiler
- Remove the hand-hole plate of the boiler and attach the hand-hole plate with the descaling ports from kit
- Connect feed and drain hoses
- Fill reservoir pail with DISSOLVE descaling liquid and insert pump

PART B – DESCALING

- Turn on power to steamer; boiler will begin to fill
- Turn on pump
- Monitor liquid levels in boiler and pail — regulate level using hand valves
- Let liquid circulate for one hour
- Turn off steamer, pump; boiler will drain

PART C – CLEAN WATER FLUSH

- Turn on steamer; boiler will fill
- Empty the pail of spent solution, refill with fresh water
- Route drain hose to floor drain
- Turn pump on and circulate for 5 minutes, monitoring water levels
- Turn off pump; close all valves; turn off steamer; boiler will drain
- Replace hand-hole plate, check gasket

PART D – TAKE DOWN AND RETURN TO SERVICE

- Turn on steamer; boiler will fill
- Remove hoses and couplings
- Activate steam switch; unit ready to operate

EQUIPMENT SETUP

1. Turn the steamer off; the boiler will drain automatically.
2. Open the door at the base of the unit.
3. Remove the hand-hole plate and gasket. Discard old gasket.
4. Inspect the boiler for scale buildup.
5. Remove any loose scale within reach that is around the hand-hole plate.
6. Install hand-hole plate with the descaler ports from kit and a new gasket.
7. Attach the 3" feed and drain nipples with the attached unions to the INLET and OUTLET ports.
8. Connect the 1/2" feed hose with attached union to the bottom of the 3" nipple.
9. Connect the 3/4" drain hose with the attached union to the top 3" nipple.
10. Make sure both feed and drain valves are closed. Drop the open end of the drain hose into the reservoir pail.
11. Fill the reservoir pail with 5 gallons of DISSOLVE descaling liquid.
12. Lower the pump into the descaling liquid. Proceed to *Descaling*.

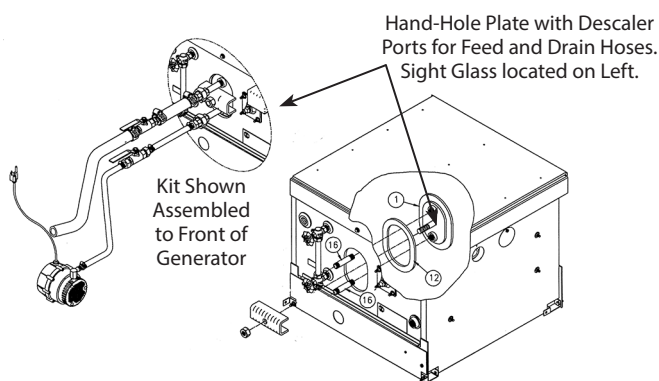

DESCALING

1. Turn the steamer power on.
 2. Turn the pump on and open the feed hose valve to the boiler. Let the boiler fill with descaler to just above the top of the sight glass before opening the drain hose valve. Make sure the drain line hose is in the pail with the pump.
- Do not allow the liquid to fall below the pump intake. Water may be added to reservoir pail to keep pump intake submerged.
- Watch for liquid at the sight glass.
3. Open the drain hose valve when the descaler reaches the level just above the top of the sight glass.
 4. While the descaler solution is circulating, keep an eye on the liquid level in the pail. Do not allow the level to fall below the pump intake or to overflow the pail. The required level can be maintained by controlling the flow with the feed hose valve.
 5. Let the pump circulate descaler for 1 hour.
 6. After 1 hour, turn the steamer power off; the boiler will automatically drain.
 7. Turn off the pump; close both the drain and feed hose valves. Proceed to *Flushing*.

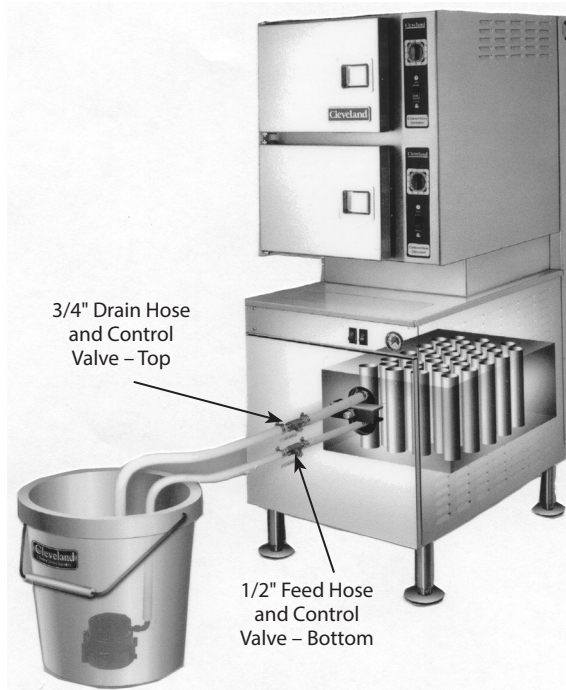

FLUSHING

1. After the boiler has drained completely, it must be flushed with water.
2. Turn the steamer back on; it will begin filling.
3. Remove the pump from the pail. Remove the drain hose from the pail.
4. Empty the spent descaling solution, refill it with fresh water and put the pump back in.
5. Do not put the drain hose back in the pail; instead, route it to a floor drain.
6. While the boiler is refilling, observe the water level in the sight glass.
7. When the level reaches the middle of the sight glass, turn on the pump and open the feed valve of the steamer.
8. When the level reaches the top of the sight glass, open the drain valve of the steamer.
9. Let the pump run 5 minutes; keep an eye on the water level in the pail; additional water may be added to keep the pump submerged.
10. After 5 minutes, turn off the pump, close the feed and drain line valves, turn off the steamer power; the boiler will automatically drain. Proceed to *Takedown and Return to Service*.

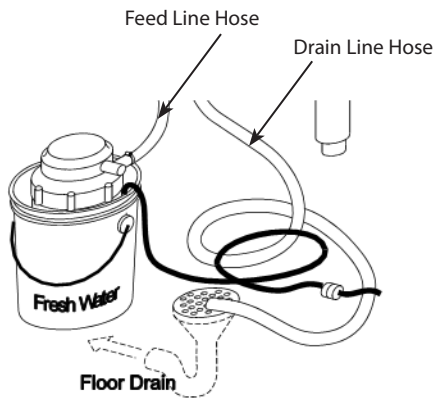
**TAKEDOWN AND RETURN TO SERVICE**

1. The steamer descaling procedure is complete; loosen the hose clamps, remove the hoses.
2. Replace the hand-hole plate with the original.
3. Turn the steamer back on; the boiler will refill.
4. When the amber steam light comes on, activate the STEAM switch to bring the unit back to operating temperature.
5. Record the current date in your descaling maintenance records.

Section 5 Troubleshooting

The Troubleshooting Guide is a list of symptoms of problems that may occur during routine operation.

- “Problem” (left column) lists common operating problems.
- “Possible Cause” (center column) lists causes of problems in the order they should be checked.
- “Remedy / Reference” (right column) lists fixes for problems from easiest to hardest.
- “Notes” in “Remedy / Reference” column are at end of the Troubleshooting Guide.

ATTEMPTING TO REPAIR OR CORRECT PROBLEMS REQUIRING A QUALIFIED CLEVELAND RANGE AUTHORIZED SERVICE REPRESENTATIVE VOIDS THE WARRANTY

Troubleshooting Guide

Problem	Possible Cause	Remedy/Reference
Switch light does not turn on when POWER switch is pressed.	Power turned off at main disconnects.	Turn on power at main disconnect switch.
POWER switch light on and steam generator does not fill.	Water supply to steamer shut off.	Open water supply valves.
	Water line strainer is clogged.	Clean water supply strainer.
	Water sensors shorted by scale, deposits.	Descalate steam generator with USDA approved descaler.
	Inoperative controls or solenoid.	See note #1.
Steam generator does not make any steam.	No water in steam generator.	See steam generator does not fill (above).
	<i>Gas models only</i> Gas supply valve closed.	Turn off steam generator and open gas supply valve. Refer to Service Manual.
	<i>Electric models only</i> Heating elements covered with scale.	Descalate steam generator with USDA approved descaler.
	<i>Electric models only</i> Heating elements damaged.	See note #1.
	Water sensors covered by scale deposits.	Descalate steam generator with USDA approved descaler.
	Inoperative controls.	See note #1.
Abnormal amount of steam coming from drain.	Hot water instead of cold water connected to condenser fitting.	Make proper connections. Refer to Installation Manual.
	Water supply to condenser turned off.	Open water supply valve.
	Condenser water line strainer is clogged.	Clean out condenser water supply line. See note #1.
	Water supply line to the condenser blocked, broken, or leaking.	Repair or replace solenoid. See note #1.
	Inoperative condenser solenoid.	Replace solenoid. See note #1.
	Inoperative controls.	Turn off electricity at main disconnect switch. See note #1.
Steam and/or water draining around compartment door	Drain clogged or covered.	Clean drain with USDA approved drain cleaner.
	Door gasket or door parts worn.	See note #1.
	Steamer not level.	See note #2.
	Hot water to condenser.	See note #2.
Reduced steam flow into cooking compartment.	Steam generator scale buildup.	Descalate steam generator with approved descaler.
	Steam nozzle scale buildup.	See note #1.
	Steam solenoids scale buildup	See note #1.
	<i>Electric models only</i> Voltage too low for unit.	See note #4.
	<i>Electric models only</i> Faulty heating element or controls.	See note #1.
Steam flow does not stop when timer stops.	Operating in manual mode.	Switch to timed mode for timer to be effective.
	Stuck open steam valve.	See note #1.
	Inoperative controls inside cabinet.	Turn off electricity at main disconnect switch. See note #1.

Problem	Possible Cause	Remedy/Reference
Water leaking from bottom of cabinet.	Broken or loose plumbing inside steamer cabinet.	Turn off electricity at main disconnect switch and close water supply valve(s). See note #1.
Water leaking from water pipes or drain lines.	Plumbing needs repair.	See note #3.
Food takes too long to cook. (Cook in perforated pans when possible.)	Not enough steam movement in compartment. Hot water connected to condenser line.	Make proper connections. Refer to Installation Manual.
	Pans too close to the bottom of cabinet.	Put pans in racks near top of cabinet.
	Steam generator scale buildup.	Descale steam generator with USDA approved descaler.
	Compartment overloaded with too much food.	Put less food in pan. Use fewer pans.
	Voltage too low for unit.	See note #4.
	Suggested cooking times are usually listed for cooking at sea level.	Extend cooking times for altitudes above 2500 feet.
Compartment bottom dirty with food drippings.	Juices and /or food leaking from pans	Put a solid pan under perforated pans to catch drippings, or put less food in pan.

TROUBLESHOOTING NOTES

1. If problem is inside the steamer, call an authorized service representative. Cleveland Range will not pay for non-warranty repair centers. For more information on products and services, contact your nearest Authorized Service Representative.
2. Proper installation of the Pressure Steamer is the responsibility of the owner or installer. Refer to Cleveland.
3. A licensed electrician should do repair to external wiring.
4. Repairs to external wiring should be done by a licensed electrician.

Every new piece of Welbilt Foodservice equipment comes with KitchenCare® and you choose the level of service that meets your operational needs from one restaurant to multiple locations

StarCare – Warranty & lifetime service, certified OEM parts, global parts inventory, performance audited

ExtraCare — CareCode, 24/7 Support, online/mobile product information

LifeCare – Install & equipment orientation, planned maintenance, KitchenConnect™, MenuConnect®

Talk with KitchenCare® • 1-844-724-CARE • www.mtwkitchencare.com



To learn how Welbilt Foodservice and its leading brands can equip you, visit our global web site at www.welbilt.com, then discover the regional or local resources available to you.