



Visit [www.clevelandrange.com](http://www.clevelandrange.com) to locate a service or sales representative in your area.

## T1 Gas Braising Pan

### Installation, Operation, Maintenance, Parts & Service

This manual is updated as new information and models are released. Visit our website for the latest manual.

**MODELS:**

- SGL-30-T1
- SGL-40-T1

*For your future reference.*

Model # \_\_\_\_\_

Serial # \_\_\_\_\_



← Model # & Serial #.



**Read the manual thoroughly.**  
**Improper installation, operation or maintenance can cause property damage, injury or death.**

**TABLE OF CONTENTS**

Statement of Responsibilities ..... 1

For your safety ..... 2

Installation ..... 4

Operating Instructions ..... 6

Cleaning Instructions ..... 7

Preventative Maintenance ..... 8

Trouble Shooting & Maintenance ..... 9

Service Parts ..... 14



# **STATEMENT OF RESPONSIBILITIES / DÉCLARATION DES RESPONSABILITÉS / DECLARACIÓN DE RESPONSABILIDADES**

This document is for use by experienced and trained Qualified Cleveland Range, LLC Authorized Service Representatives who are familiar with both the safety procedures, and equipment they service. Cleveland Range, LLC assumes no liability for any death, injury, equipment damage, or property damage resulting from use of, improper use of, or failure to use the information contained in this document. Cleveland Range, LLC has made every effort to provide accurate information in this document, but cannot guarantee that this document does not contain unintentional errors and omissions.

The information in this document may be subject to technical and technological changes, revisions, or updates. Cleveland Range, LLC assumes no liability or responsibility regarding errata, changes, revisions, or updates.

Qualified Cleveland Range, LLC Authorized Service Representatives are obligated to follow industry standard safety procedures, including, but not limited to, OSHA regulations, and disconnect / lock out / tag out procedures for all utilities including steam, and disconnect / lock out / tag out procedures for gas, electric, and steam powered equipment and / or appliances.

All utilities (gas, electric, water and steam) should be turned OFF to the equipment and locked out of operation according to OSHA approved practices during any servicing of Cleveland Range equipment

Qualified Cleveland Range, LLC Authorized Service Representatives are obligated to maintain up-to-date knowledge, skills, materials and equipment.

Ce document est destiné à l'usage des Représentants de Service qualifiés et autorisés de Cleveland Range, LLC qui possèdent l'expérience et la formation ainsi que la bonne connaissance des mesures de sécurité et du matériel qu'ils entretiennent.

Cleveland Range, LLC décline toute responsabilité pour tout cas de décès, blessure, dommage matériel ou dommage aux biens résultant de l'utilisation, de la mauvaise utilisation ou du manquement d'utilisation des renseignements contenus dans ce document.

Cleveland Range, LLC s'est efforcé à fournir des renseignements précis dans ce document mais ne peut garantir que ce document soit exempt d'erreurs et d'omissions non intentionnelles.

Les renseignements contenus dans ce document peuvent être assujettis à des changements techniques et technologiques, des révisions ou des mises à jour.

Cleveland Range, LLC décline toute obligation ou responsabilité concernant les errata, modifications, révisions ou mises à jour.

Les Représentants de Service qualifiés et autorisés de Cleveland Range, LLC sont tenus de se conformer aux mesures de sécurité normalisées de l'industrie, y compris, mais sans s'y limiter, les réglementations de l'OSHA, les procédures de débranchement / verrouillage / étiquetage relatives à tous les services publics, dont l'approvisionnement en vapeur, et les procédures de débranchement / verrouillage / étiquetage relatives aux équipements et/ou appareils fonctionnant au gaz, à l'électricité et à la vapeur.

Au cours de tout entretien d'un appareil Cleveland Range, tous les services publics (gaz, électricité, eau et vapeur) doivent être FERMÉS au niveau de l'appareil et le dispositif de fonctionnement doit être verrouillé suivant les pratiques approuvées de l'OSHA.

Les Représentants de Service qualifiés et autorisés de Cleveland Range, LLC sont tenus d'actualiser en permanence leurs connaissances, compétences, matériel et équipement.

Este documento está destinado para el uso de los Representantes de Servicio calificados y autorizados de Cleveland Range, LLC quienes cuentan con la experiencia y la capacitación así como el buen conocimiento de las medidas de seguridad y de los equipos que mantienen.

Cleveland Range, LLC, declina toda responsabilidad en caso de cualquier fallecimiento, lesiones, daños al equipo o daños a la propiedad resultantes de la utilización, del uso indebido o de la falta de utilización de la información provista en este documento.

Cleveland Range, LLC se ha esforzado en suministrar información precisa en este documento, pero no puede garantizar que este documento esté exento de errores y de omisiones no intencionales.

La información contenida en este documento podría estar sujeta a cambios técnicos o tecnológicos, revisiones o actualizaciones. Cleveland Range, LLC declina toda obligación o responsabilidad con respecto a erratas, modificaciones, revisiones o actualizaciones.

Los Representantes de Servicio calificados y autorizados de Cleveland Range, LLC tienen la obligación de seguir los procedimientos estándar de seguridad de la industria; los cuales incluyen pero no se limitan a los reglamentos de la OSHA (La Administración de la Seguridad y Salud Ocupacionales), los procedimientos de desconexión, cierre y etiquetado relativos a todos los servicios públicos incluyendo el suministro de vapor y los procedimientos de desconexión, cierre y etiquetado para los equipos y/o aparatos que funcionan a base de gas, electricidad o vapor.

Cuando se esté dando servicio o mantenimiento a un aparato de Cleveland Range, todos los servicios públicos (gas, electricidad, agua y vapor) deben estar APAGADOS para el equipo en cuestión y se debe seguir el procedimiento de cierre de operaciones de acuerdo con las prácticas aprobadas por la OSHA.

Los Representantes de Servicio calificados y autorizados de Cleveland Range, LLC tienen la obligación de actualizar constantemente sus conocimientos, destrezas, materiales y equipamiento.

# **FOR YOUR SAFETY / POUR VOTRE SÉCURITÉ / PARA SU SEGURIDAD**

## **FOR YOUR SAFETY**

**Do not store or use gasoline or any other flammable liquids and vapours in the vicinity of this or any other appliance.**

## **POUR VOTRE SÉCURITÉ**

**Ne pas entreposer ou utiliser d'essence ou d'autres liquides ou vapeurs inflammables à proximité de cet appareil ou de tout autre appareil.**

## **PARA SU SEGURIDAD**

**No guarde ni use gasolina o cualesquiera otros líquidos o vapores inflamables en las cercanías de éste o cualquier otro aparato.**

**WARNING: Improper installation, operation, adjustment, alteration, service or maintenance can cause property damage, injury or death. Read the installation and operating instructions thoroughly before installing, operating or servicing this equipment.**

**AVERTISSEMENT : Toute mauvaise pratique en matière d'installation, de fonctionnement, de réglage, de modification, d'entretien ou de maintenance peut causer des dommages matériels, des blessures ou la mort. Lisez la totalité des instructions d'installation et d'utilisation avant d'installer, d'utiliser ou d'entretenir cet équipement.**

**ADVERTENCIA: La indebida instalación, operación, ajuste, modificación, servicio o mantenimiento puede ocasionar daños a la propiedad, lesiones o muerte. Lea detenidamente las instrucciones de instalación y de operación antes de instalar, poner a funcionar o dar servicio a este equipo.**

Do not spray aerosols in the vicinity of this appliance while it is in operation.

This appliance is not to be used by persons with reduced physical, sensory or mental capabilities, or lack of experience and knowledge, unless they have been given supervision or instruction concerning use of the appliance by a person responsible for their safety.

This appliance is not for use by children and they must be supervised not to play with it.

Post in a prominent location, instructions to be followed in the event the user smells gas. This information shall be obtained by consulting your local gas supplier.

Do not obstruct the flow of combustion and ventilation air.

Retain this manual for your reference.

Ne pas pulvériser des aérosols dans le voisinage de cet appareil alors qu'il est en fonctionnement.

Cet appareil ne doit pas être utilisé par des personnes dont les capacités physiques, sensorielles ou mentales sont réduites, ou des personnes dénuées d'expérience ou de connaissance, sauf si elles ont pu bénéficier, par l'intermédiaire d'une personne responsable de leur sécurité, d'une surveillance ou d'instructions préalables concernant l'utilisation de l'appareil.

Cet appareil n'est pas destiné à être utilisé par des enfants et ils doivent être surveillés pour s'assurer qu'ils ne jouent pas avec l'appareil.

Affichez à un endroit bien visible les instructions à suivre dans le cas où l'utilisateur sent une odeur de gaz. Ces informations seront obtenues auprès de votre fournisseur de gaz local.

Ne pas obstruer le flux d'air de combustion et de ventilation.

Conservez ce manuel pour votre référence.

No pulverice aerosoles en las proximidades de este aparato mientras está en funcionamiento.

Este aparato no debe ser utilizado por personas con capacidades físicas, sensoriales o mentales reducidas, o que no tengan la experiencia y los conocimientos adecuados, a menos que estas personas hayan recibido supervisión e instrucciones en cuanto al uso del aparato por la persona responsable de la seguridad de ellas.

Este aparato no debe ser usado por los niños y ellos deben ser supervisados para que no jueguen con el aparato.

No obstruya el flujo del aire combustión y de ventilación.

Guarde este manual para su referencia.



## WARNING / AVERTISSEMENT / ADVERTENCIA



Improper installation, operation, adjustment, alteration, service or maintenance can cause property damage, injury or death. Read the installation and operating instructions thoroughly before installing, operating or servicing this equipment. / Toute mauvaise pratique en matière d'installation, de fonctionnement, de réglage, de

modification, d'entretien ou de maintenance peut causer des dommages matériels, des blessures ou la mort. Lisez la totalité des instructions d'installation et d'utilisation avant d'installer, d'utiliser ou d'entretenir cet équipement. / La indebida instalación, operación, ajuste, modificación, servicio o mantenimiento puede ocasionar daños a la propiedad, lesiones o muerte. Lea detenidamente las instrucciones de instalación y de operación antes de instalar, poner a funcionar o dar servicio a este equipo.



Keep hands away from moving parts and pinch points. / Gardez les mains loin des pièces mobiles et des points de pincement. / Mantenga las manos lejos de piezas móviles y puntos de presión muy localizada.



Surfaces and product may be hot! Wear protective equipment. / Les surfaces et le produit peuvent être chauds! Portez un équipement de protection. / ¡Las superficies y el producto pueden estar calientes! Utilice equipo protector.



Hot product and surfaces. / Produit et surfaces chaudes. / Producto y superficies calientes.

Do not touch. / Ne pas toucher. / No la toque



Do not climb, sit or stand on equipment. / Il ne faut pas monter, s'asseoir ni se tenir debout sur l'équipement. / No subirse, ni sentarse ni pararse sobre el equipo.



Stand clear of product discharge path when discharging hot product. / Écartez-vous du chemin de décharge d'un produit chaud. / Permanezca alejado de la ruta de descarga del producto al vaciar producto caliente.



Do not lean on or place objects on lip. / Ne vous penchez pas sur ou ne placez pas des objets sur la lèvres. / No se apoye ni coloque objetos en el labio.



Inspect unit daily for proper operation. / Inspectez l'unité tous les jours pour son bon fonctionnement. / Inspeccione diariamente el funcionamiento correcto de la unidad.



Keep appliance and area free and clear of combustibles. / Gardez l'appareil et son entourage libre de tous combustibles. / Mantenga el aparato y el área libres de combustibles.



Do not attempt to operate this appliance during a power failure. / N'essayez pas de faire fonctionner cet appareil lors d'une panne de courant. / No intente poner en marcha este aparato durante un fallo de suministro eléctrico.



Unit exhaust contains carbon monoxide. Operate only under a properly functioning hood with adequate make-up air. / L'échappement de l'unité émet du monoxyde de carbone. Exploiter uniquement sous une hotte fonctionnant correctement avec une source adéquate d'air d'appoint. / El escape de la unidad contiene monóxido de carbono. Operar solamente bajo una campana en buen funcionamiento con aire de relleno adecuado.



Floor may become slippery from product spillage. / Déversement de produit peut causer de plancher à être glissant. / Derrame de producto puede causar piso a ser resbaladizo.



Unit must be anchored as per manual. / Unité doit être ancrée selon les directives du manuel. / Unidad debe estar fijado según el manual.



Heavy / Lourd / Pesado

Team or mechanical lift. / Équipe ou remontée mécanique. / Equipo o elevador mecánico.

## IMPORTANT / IMPORTANT / IMPORTANTE

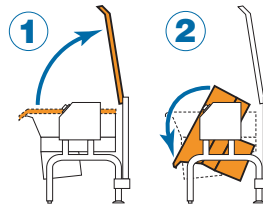

Lift lid before tilting skillet.

Ôtez le couvercle avant d'incliner la chaudière à frire.

Levante la tapa antes de inclinar la sartén.

## SERVICING / ENTRETIEN / SERVICIO



Shut gas supply off prior to servicing. / Fourniture de gaz fermée au loin avant d'entretenir. / Suministro de gas cerrado apagado antes del mantenimiento.



Remove electrical power prior to servicing. / Coupez l'alimentation électrique avant l'entretien. / Desconnecte la energía eléctrica antes de darle servicio.

Risk of electric shock. / Risque de choc électrique. / Riesgo de choque eléctrico.



Have a qualified service technician maintain your equipment. / Demandez à un technicien en entretien et en réparation qualifié d'effectuer l'entretien de votre équipement. / Haga que un técnico de servicio calificado mantenga su equipo

# INSTALLATION

## GENERAL

Insure gas and electrical supplies match rating plate. The rating plate is located on the right side of the unit.

Installation of the unit must be accomplished by qualified installation personnel working to all applicable local and national codes.

This equipment is built to comply with applicable standards for manufacturers. Included among those approval agencies are: UL, A.G.A., NSF, ASME/N.Bd., CSA, CGA, ETL, and others. Many local codes exist, and it is the responsibility of the owner/installer to comply with these codes.

Observe all clearance requirements. Do not obstruct the flow of combustion and ventilation air.

## RECEIVING INSPECTION

Before unpacking visually inspect the unit for evidence of damage during shipping.

If damage is noticed, do not unpack the unit, follow shipping damage instructions.

## SHIPPING DAMAGE INSTRUCTIONS

If shipping damage to the unit is discovered or suspected, observe the following guidelines in preparing a shipping damage claim.

1. Write down a description of the damage or the reason for suspecting damage as soon as it is discovered. This will help in filling out the claim forms later.
2. As soon as damage is discovered or suspected, notify the carrier that delivered the shipment.
3. Arrange for the carrier's representative to examine the damage.
4. Fill out all carrier claims forms and have the examining carrier sign and date each form.

## APPROXIMATE WEIGHTS

Model #	Unit	Unit with shipping box
SGL-30-T1	520 lbs.	560 lbs.
SGL-40-T1	610 lbs.	650 lbs.



## UNCRATING

### CAUTION:

Straps under tension and will snap when cut. Carton may contain staples and skid contains nails. Use proper safety equipment and precautions. Unit is heavy. Use adequate help or lifting equipment as needed.



1. Cut straps and remove box.



2. Cut straps on unit.



3. Remove screws from back of flanged feet (x6).



4. Remove nails to free blocks on front legs.

## VENTILATION

Gas fired units are only to be installed under a ventilation hood in a room which has provisions for adequate make up air. Further information can be obtained by referring to the U.S.A. National Fire Protection Associations NFPA96 regulations. These standards have also been adopted by the National Building Code in Canada.



## CLEARANCE REQUIREMENTS/ DRAIN LOCATIONS

This unit must be installed in accordance with the clearances shown on the rating label which is adhered to the unit.

**FOR YOUR SAFETY.** Keep the appliance area free and clear of combustible materials.

## POSITIONING

This unit must be installed in accordance with the clearances shown on the rating label which is adhered to the unit.

1. Position the unit in its permanent location.
2. Level skillet by means of adjustable stainless steel feet. Use a spirit level and level unit four ways; across front and back and down left and right edges.
3. Once positioned and leveled, permanently secure the unit's flanged feet to the floor using 5/16" lag bolts and floor anchors (supplied by the installer). Three bolts are required to secure each of the flanged feet.
4. Seal joints of flanged feet with a silicone sealant.
5. Remove any protective material covering stainless steel panels.

## GAS

### **ENSURE THE GAS SUPPLY MATCHES THE KETTLE'S REQUIREMENTS AS STATED ON THE RATING PLATE.**

Installation must conform, with local codes or in the absence of local codes, with the National Fuel Gas Code ANSI Z223.1/NFPA 54, or the Natural Gas and Propane Installation Code, CSA B149.1 and B149-2 (Canada).

The appliance and its individual shut-off valve must be disconnected from the gas supply piping system during any pressure testing of that system at test pressures in excess of 1/2 psi (3.45 kPa).

The appliance must be isolated from the gas supply piping system by closing its individual manual shut-off valve during any pressure testing of the gas supply piping system at test pressures equal to or less than 1/2 psi (3.45 kPa).

It is recommended that a sediment trap (drip leg) be installed in the gas supply line. If the gas pressure exceeds 1/2 psi (3.45 kPa), a pressure regulator must be installed, to provide a maximum of 1/2 psi (3.45 kPa) gas pressure to the gas control valve.

Connect the gas line to the manual valve located at the rear left hand side. Use pipe joint sealant that is approved for use with liquefied petroleum gas.

Use a gas pipe joint compound which is resistant to L.P. gas. Test all pipe joints for leaks with soap and water solution. Ensure that the gas pressure regulator is set for the manifold pressure indicated on the gas rating plate.

## CASTERS (OPTIONAL)

Units supplied with casters must be installed using connector complying with ANSI Z21.69 ·CGA 6.16 and quick-disconnect device complying with ANSI Z21.41 ·CGA 6.9. It must also be installed with a restraining means to guard against transmission of strain to the connector as specified in the appliance manufacturer's instructions.

1. Add restraint cable to unit as shown.
2. Fasten other end of restraint cable to guard against transmission of strain to the gas connector or electrical connection.
3. For gas units install gas connections using a connector complying with ANSI Z21.69 \* CGA6.16 and a quick disconnect device complying with ANSI Z21.41 \* CGA6.9.
4. When properly installed the strain relief will become tight and stop movement of the unit before strain is put on gas plumbing or electrical connection.



## ELECTRICAL

### **ENSURE THE ELECTRICAL SUPPLY MATCHES THE UNIT'S REQUIREMENTS AS STATED ON THE RATING LABEL.**

#### **⚠ WARNING:**

##### *Electrical Grounding Instructions.*

This unit is equipped with a three-prong (grounding) plug for your protection against shock hazard and should be plugged directly into a properly grounded three-prong receptacle. Do not cut or remove the grounding prong from this plug.

A cord and plug are supplied with the 115 volt unit. Simply plug the unit into any grounded outlet rated for a minimum of 10 amps.

Standard supply voltage is 115 volts A.C., however, optional A.C. voltages can be supplied on special order. A separate fused disconnect switch must be supplied and installed in the high voltage electrical supply line. The unit when installed, must be electrically installed and grounded in accordance with local codes, or in the absence of local codes, with National Electrical Code, ANSI/NFPA 70-1990 (USA) or the Canadian Electrical Code, CSA C22.2, Part 1 (Canada)

When a unit is ordered and built for 208/240 volt, the supply line must be connected to the wiring terminations located inside the console. Wiring diagram is located on the bottom side of component enclosure cover..

The wiring diagram is located on the back of the console access panel.

## WATER CONNECTION

(OPTIONAL)

A 1/2" NPT cold water line and/or a 1/2" NPT hot water line are required if unit is equipped with a single or double pantry faucet.

## INSTALLATION CHECKS

Although the unit has been thoroughly tested before leaving the factory, the installer is responsible for ensuring the proper operation of unit once installed.

1. Supply power to the unit by placing the fused disconnect switch to the "ON" position.
2. Turn on main gas supply to unit. Open the unit's shut-off valve (located at lower rear left).
3. Toggle Switch to the "HI" or "LO" position.
4. For your safety the unit is equipped with a power interrupter which automatically shuts off the gas supply to the burners whenever the unit is raised more than 8°.
5. Turn temperature control to maximum. Tilt pan until heat indicator light turns off and heating system shuts down. The pan should be on a 5-10° angle.
6. Lower pan. Heat indicator light will re-light and heating system will re-energize.
7. Unit will continue to heat, heat indicator light will remain on until temperature is reached. Then the heat indicator light will cycle OFF indicating the heating system has shut off. The heat indicator light will continue to cycle ON and OFF as the heating system cycles ON and OFF maintaining the desired temperature.
8. Toggle HI / OFF / LO Switch to the "OFF" position.
9. Check carbon monoxide is less than 0.08 percent in an air-free sample of the flue gases. See FREE AIR CALCULATION procedure in "Maintenance Procedures & Parts Lists" manual.

## CLEANING

After installation the unit must be thoroughly cleaned and sanitized prior to cooking

# OPERATING INSTRUCTIONS

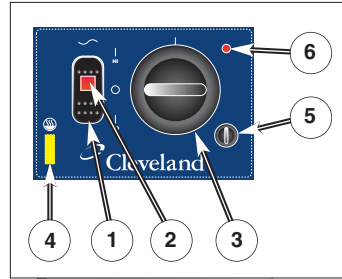

## # DESCRIPTION

1. HI / OFF / LO Switch
2. Power Indicator Light (red)
3. Temperature Dial
4. Heat Indicator Light (yellow)
5. Power Tilt Switch (location may vary)
6. Reset Button (location may vary)
7. Manual Tilt Override
8. Gas Shut Off Valve

## POWER TILT MANUAL OVERRIDE

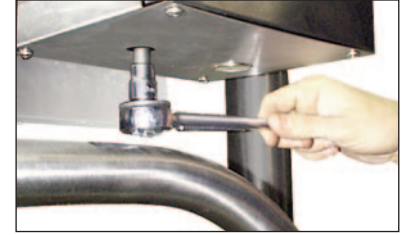

In case of power failure or malfunction the skillet pan can be tilted manually following these instructions.

1. (prior to May 2006) - Fit a 10mm SIX point socket over the Manual Tilt Shaft as shown above.  
(after May 2006) - Fit a 1/2" SIX point socket over the Manual Tilt Shaft as shown above.
2. Turn socket wrench clockwise to empty contents.

## OPERATING THE UNIT

1. Perform daily startup inspection.



### FOR YOUR SAFETY:

This unit will automatically shut off the gas supply when pan is raised more than 8°.

Before commencing to cook, ensure pan is in the lowered position.

2. **MANUAL TILT:** Cleveland braising pans are equipped with a manual tilt mechanism for raising and lowering the pan. To raise pan, raise the cover and turn the crank clockwise. To lower pan, turn counterclockwise.

**POWER TILT:** Cleveland braising pans can also be equipped with an optional electric power tilt mechanism for raising and lowering the pan. To raise pan, raise the cover and press up on the tilt switch. To lower pan, press down on the tilt switch.

3. Toggle HI / OFF / LO Switch to the "HI" or "LO" position. The red Power Indicator Light indicates power is on. The yellow Heat Indicator Light indicates burners are on.
4. To preheat, set Temperature Dial to desired cooking temperature. Unit is preheated when the yellow light goes out.
5. Insert product in pan.
6. If desired, once product has cooked, it can be held prior to serving at a lower temperature setting.
7. When cooking is completed, set Temperature Dial and HI / OFF / LO Switch to the OFF position.
8. The best time to clean the unit is immediately after use, once unit has cooled down. Refer to section titled "CLEANING INSTRUCTIONS" for details.



### OPEN COVER BEFORE TILTING PAN

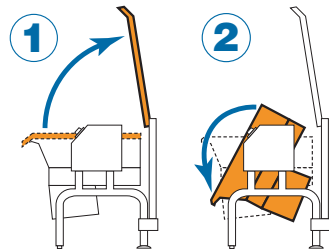

### FOR YOUR SAFETY:

If ignition fails and/or the control system goes into lockout, set power switch to the "OFF" position.

Wait 5 minutes then repeat steps 1 through 3. If the problem persists, have a qualified serviceman check the system.



### ⚠️ WARNINGS:

If for any reason this unit is not functioning correctly **DO NOT OPERATE**. Contact your authorized service agent.

- Casters must be locked at all times (unless unit is being moved). Check before use.
- Roll unit only on hard and smooth surfaces.
- DO NOT move unit with product in pan.
- DO NOT place unit on incline greater than 5 degrees. Failure to follow these rules can cause serious injury or death.

## OPERATING SUGGESTIONS

1. Turn power switch to the "OFF" position when unit is not in use.
2. Allow unit to preheat before adding product.
3. Always lift the spring assist cover before activating the tilt mechanism.
4. During an electrical power interruption, turn Power Switch to the OFF position. This unit cannot be made to operate without electrical power.

# CLEANING INSTRUCTIONS



DO NOT HOSE  
DOWN THIS  
AREA

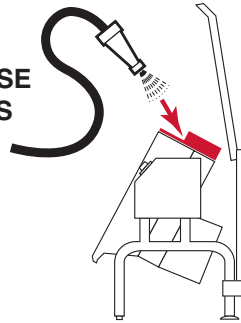

## CARE AND CLEANING

Cooking equipment must be cleaned regularly to maintain its fast, efficient cooking performance and to ensure its continued safe, reliable operation. The best time to clean is shortly after each use (allow unit to cool to a safe temperature).

## WARNINGS



Chloride Cleaners

Do not use detergents or cleansers that are chloride based or contain quaternary salt.



Wire Brush & Scrapers

Do not use a metal bristle brush or scraper.



Steel Pads

Steel wool should never be used for cleaning the stainless steel.

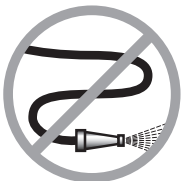

High Pressure Spray Hose

Unit should never be cleaned with a high pressure spray hose.



Stagnant Water

Do not leave water sitting in unit when not in use.

## CLEANING INSTRUCTIONS

1. Turn unit off.
2. Remove drain screen (if applicable). Thoroughly wash and rinse the screen either in a sink or a dishwasher.
3. Prepare a warm water and mild detergent solution in the unit.
4. Remove food soil using a nylon brush.
5. Loosen food which is stuck by allowing it to soak at a low temperature setting.
6. Drain unit.
7. Rinse interior thoroughly.
8. If the unit is equipped with a **Tangent Draw-Off Valve**, clean as follows:
  - a) Disassemble the draw-off valve first by turning the valve knob counter-clockwise, then turning the large hex nut counter-clockwise until the valve stem is free of the valve body.
  - b) In a sink, wash and rinse the inside of the valve body using a nylon brush.
  - c) Use a nylon brush to clean tangent draw-off tube.
  - d) Rinse with fresh water.
  - e) Reassemble the draw-off valve by reversing the procedure for disassembly. The valve's hex nut should be hand tight only.
9. Using mild soapy water and a damp sponge, wash the exterior, rinse, and dry.

## NOTES

- ⇒ For more difficult cleaning applications one of the following can be used: alcohol, baking soda, vinegar, or a solution of ammonia in water.
- ⇒ Leave the cover off when the kettle is not in use.
- ⇒ For more detailed instructions refer to Stainless Steel Equipment Care and Cleaning ([www.nafem.org/resources/stainlesssteelfinal.doc](http://www.nafem.org/resources/stainlesssteelfinal.doc)) on Nafem's website ([www.nafem.org](http://www.nafem.org)).

## DISPOSAL INSTRUCTIONS

This unit is recyclable. Do not dispose in landfill.

The majority of the unit is composed of stainless steel. Other alloys and electrical components make up a small percentage of the total. Follow Federal, state and local regulations for disposal.





# PREVENTATIVE MAINTENANCE

FOR MAINTENANCE AND REPAIRS CONTACT YOUR AUTHORIZED  
MANITOWOC SERVICE AGENCY AND HAVE A QUALIFIED  
SERVICE TECHNICIAN MAINTAIN YOUR EQUIPMENT.



Cleveland Range equipment requires little preventative maintenance. We do however provide the following guidelines for inspection and maintenance to keep your unit functioning at 100%.



## DAILY PRE-STARTUP INSPECTION

1. Cover tilts up and down freely and is held in place when fully open.
2. Draw-Off Valve (if equipped) is installed and handle is in place.
3. Tilt hand wheel is tight (if equipped).
4. Tilt switch (if equipped) (5) is not broken and is functioning properly.
5. Pan tilts up and down correctly.
6. Temperature dial (3) is in place and functioning properly.
7. Red Light (2) comes on when unit is turned on.
8. Orange Light (4) is on when unit is heating.
9. Orange Light (4) is off when unit is tilted.
10. If unit is equipped with casters ensure they are functional and in a locked position.

**WARNING:**



If for any reason this unit is not functioning correctly **DO NOT OPERATE**. Contact your authorized service agent.

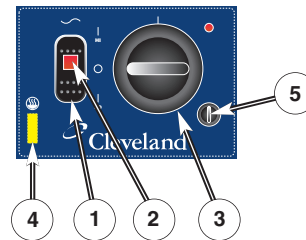

## SIX MONTH SERVICE INSPECTION

1. Perform daily startup inspection.
2. There are no hydraulic oil leaks.
3. Adequate exhaust and makeup air is supplied to working area.
4. Console cover is in place and securely fastened.
5. All panels are in place and securely fastened.
6. If unit is equipped with casters check that caster locks are functional and caster wheels and bearings are not damaged.

## YEARLY SERVICE INSPECTION

1. Perform six month service inspection.
2. Inspect safety thermostat for proper connections.
3. Clean blower.
4. Perform free air calculation (see FREE AIR CALCULATION).
5. Inspect burner gasket (see BURNER GASKET INSPECTION).

# TROUBLESHOOTING AND MAINTENANCE PROCEDURES

The following trouble shooting guide and maintenance procedures are meant to be used by Qualified Service Technician



For periodic maintenance recommendations see “Operators Manual”.

## SEQUENCE OF OPERATIONS

When using these instructions refer to the SGL-TI wiring schematic.

- 115 VAC is sent through the 3 amp fuse to
  - The primary of the 24 VAC transformer
  - 24 VAC is sent from the secondary of the 24VAC transformer to the Hi/Off/Low Switch.
  - Contacts of the RI Blower Relay
  - The optional Power Tilt Circuit
- With the Hi/Off/Low switch in the Low position.
  - 24 VAC is sent through the normally closed high limit switch to the mercury switch.
  - If the unit is in the down position then 24 VAC is sent through mercury switch to pin 9 on the thermostat.
- With the Hi/Off/Low Switch in the Hi position 24 VAC is also sent to the Hi terminal on the gas valve.
  - Gas will not leave the valve until the main gas valve opens (see step 7).
- If the steamer is calling for heat the 24 VAC is sent from pin number 10 to R1 Blower Relay.
  - The normally open contacts of the blower relay close sending 115 VAC to the blower.
  - The blower turns closing the air switch.
  - 24 VAC is sent through the now closed air switch to the ignition module.
- Ignition module sends spark from terminal SP to the igniter.
- Ignition module also sends 24 VAC from pins PV and MV/PV to the pilot coil of the gas valve pins P and C.
  - Pilot valve opens sending gas to the Pilot assembly.
  - Spark and gas meet and pilot is ignited.
  - AC current is passed through the flame and rectified then sent back to the ignition module.
- If the ignition module reads a minimum of 1.0 micro-amps through the burner ground then 24 VAC is sent from pins MV and MV/PV of the ignition module to pins M and C on the Gas valve.
  - The main (low) gas valve opens and gas (3.0" W.C. natural gas or 8.0" W.C. LP) is sent to the burner.
  - If the unit is in the Hi position (see step 3) 24VAC will be at the HI terminal and the gas pressure will be 3.5" W.C. natural or 10.0" W.C. LP.
  - Burner ignites until thermostat is satisfied.
- When thermostat is satisfied, 24 VAC is removed from pin 10 on the thermostat and the heat circuit is de-energized
- If the unit has the optional Power Tilt option and is in the down position, 115 VAC is sent from the customer connect through the circuit breaker and the up limit switch to the tilt switch.
- With the tilt switch in switch in the Up position
  - 115 VAC is sent to the Bridge Rectifier
  - 115 VDC is sent from the rectifier through the 30-ohm resistor to the normally open RY10 and RY11 relay contacts.
  - 115 VAC is sent to the RY 10 relay coil.
  - The normally open RY10 contact close and 90 VDC is sent to the DC motor
  - The DC motor is energized and the unit tilts until the switch is released or the up limit switch opens.
- With the Tilt switch in the Down position
  - 115 VAC is sent to the Bridge Rectifier
  - 115 DC is sent from the rectifier through the 30-ohm resistor to the normally open RY10 and RY11 relay contacts.
  - 115 VAC is sent to the RY 11 relay coil.
  - The normally open RY 11 contact close and the polarity of the 90 VDC is reversed.
  - The DC motor is energized and the unit lowers until the switch is released or the Down limit switch opens.

# BURNER ASSEMBLY INSPECTION

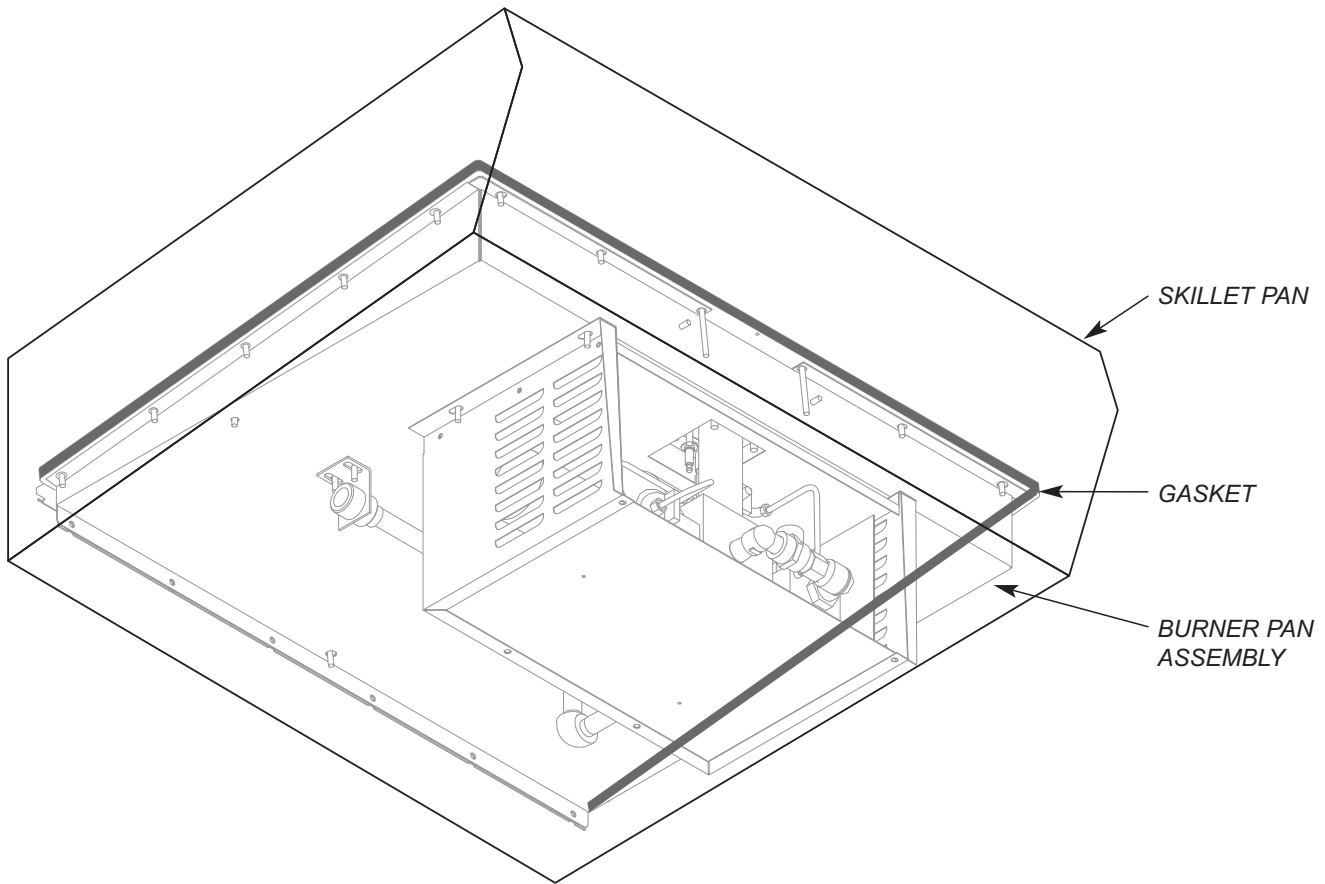

1. Turn unit to ON. The burner must be firing during this procedure.
2. Using a stainless steel extension mirror, inspect gasket between burner pan assembly and skillet pan (sides and front only).
3. Replace gasket if a flame can be seen coming through the gasket

## GASKET PART #s

	30 GALLON	40 GALLON
<b>SIDES</b>	SK2472402	SK2472402
<b>FRONT</b>	SK2472400	SK2472401

## HINGE ADJUSTMENT INSTRUCTIONS

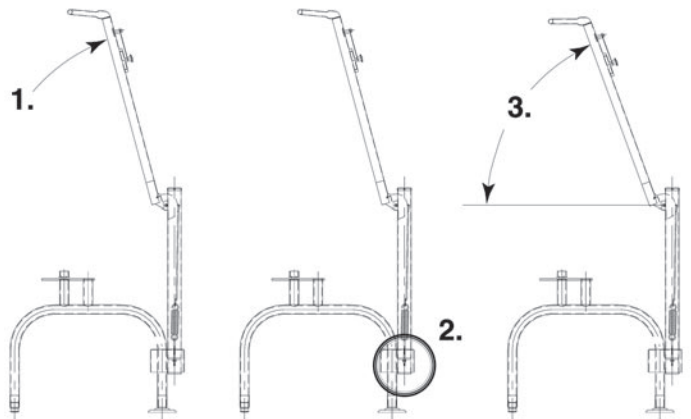

1. Fully lift cover to release spring tension.
2. Using a 7/16" deep socket adjust left and right bolts evenly.
3. When properly adjusted, cover should rest at 70°.

## LUBRICATION PROCEDURE

Lubricate the following parts every three months to insure smooth operation and reduce wear.

The worm screw and tilt gear are accessed through the top cover of the console. Apply grease to gear teeth. Check for excessive play and adjust with adjusting screw located on top of cross bar.

On the left hand side of the skillet there are two grease nipples on the top back portion of the trunnion housing.

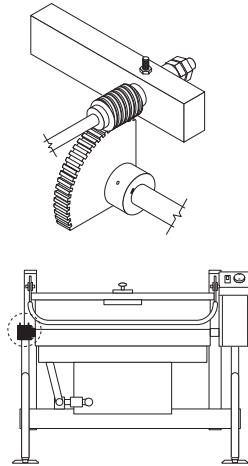

## FREE AIR CALCULATION

Insert drager pump tube 4" down the center of the flue and take one sample each of Carbon Dioxide (CO<sub>2</sub>) and Carbon Monoxide (CO) and record results.

With results obtained for CO<sub>2</sub> use chart to determine dilution factor for gas type used.

Enter these numbers in the following formula to determine the concentration of carbon monoxide in an air free sample of flue gas.

% CO (PPM)	% CO <sub>2</sub>
Dilution Factor	

$$\text{Dilution Factor} \times \frac{\text{CO (PPM)}}{10,000} = \frac{\quad}{\quad} \text{ \% Carbon Monoxide}$$

Result must not exceed 0.08% carbon monoxide.

CARBON DIOXIDE IN SAMPLE (PERCENT)	FACTOR PROPANE GAS	FACTOR NATURAL GAS
4.0	3.50	3.05
4.2	3.33	2.90
4.4	3.18	2.77
4.6	3.04	2.65
4.8	2.92	2.54
5.0	2.80	2.44
5.2	2.69	2.34
5.4	2.59	2.26
5.6	2.50	2.18
5.8	2.41	2.10
6.0	2.33	2.03
6.2	2.26	1.97
6.4	2.19	1.91
6.6	2.12	1.85
6.8	2.06	1.80
7.0	2.00	1.74
7.2	1.94	1.70
7.4	1.89	1.65
7.6	1.84	1.61
7.8	1.79	1.56
8.0	1.75	1.53
8.2	1.71	1.49
8.4	1.67	1.45
8.6	1.63	1.42
8.8	1.59	1.39
9.0	1.56	1.36
9.2	1.52	1.33
9.4	1.49	1.30
9.6	1.46	1.27
9.8	1.43	1.24
10.0	1.40	1.22

## SPARE PARTS LIST

PART NO.	DESCRIPTION	QTY.
SK2474500	SWTCH, TILT LIMIT	1
KE53838-25	TRANSFORMER	1
KE52936-8	FUSE, 1.25 AMP	1
KE52936-6	FUSE, 3 AMP	1
SK00397-1	GAS IGNITION CONTROL ASSEMBLY	1
SK50933-1	TEMPERATURE SENSOR (RTD)	1
SK2488200	GAS VALVE, NATURAL GAS	1
SK2488201	GAS VALVE, LP	1
FA15019-6	SHOULDER BOLT	1
FA21024	5-16 HEX NUT, 18-8 S.S.	1
SK2498399	POTENTIOMETER SHAFT ASSEMBLY	1
<i>INCLUDES:</i>		
SK2166800	POTENTIOMETER SHAFT	1
SK2167000	TENSION PIN	1
SK2167100	WASHER, BOWED/SPRING	1
SK2167200	RETAINING RING, SP-NR #R1000-25	1
SK2167300	PANEL BEARING	1
SK2382800	RETAINING RING CLIP	1
SK50905-1	INDICATOR LIGHT CLEAR, 28V	1
SK2142002	THERMOSTAT	1
SK2477000	IGNITOR/PILOT ASSEMBLY	1
SK2488300	GAS REGULATOR	1
SK2475300	GAS CONTROL MODULE	1
KE55069-7	SAFETY THERMOSTAT	1
SK2475500	RELAY	1
SK2474102	SWITCH, ON/OFF/ON, DUAL FIRING	1
<b>POWER TILT ONLY</b>		
KE53137-3	TILT SWITCH, ON/OFF/ON	1
KE53184	CONTACT SECTION HOLDER (LATCH)	1
KE53138-1	CONTACT BLOCK	4
KE50579-2	CIRCUIT BREAKER	1
FA05002-34	"O" RING, CIRCUIT BREAKER	1
KE50580	WATER RESISTANT BOOT	1

# WIRING DIAGRAMS

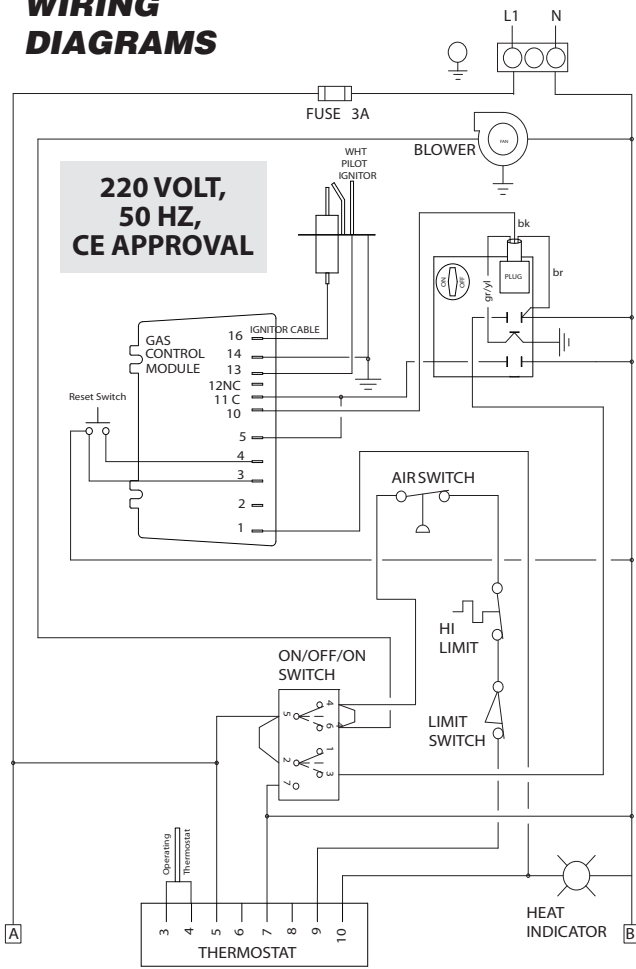

**220 VOLT,  
50 HZ,  
CE APPROVAL**

POWER TILT OPTION

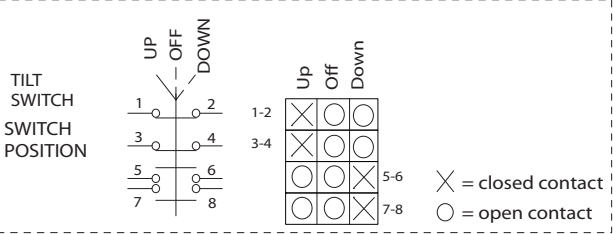
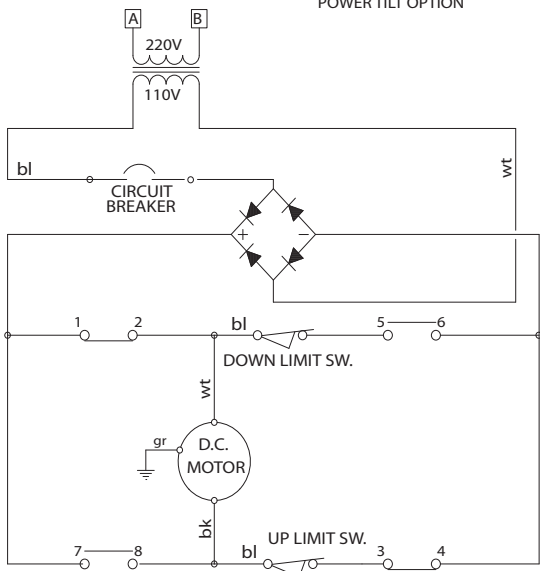

SK90125-8 REV. A

**110-120 VOLT, 60HZ,  
UL, CSA APPROVALS**

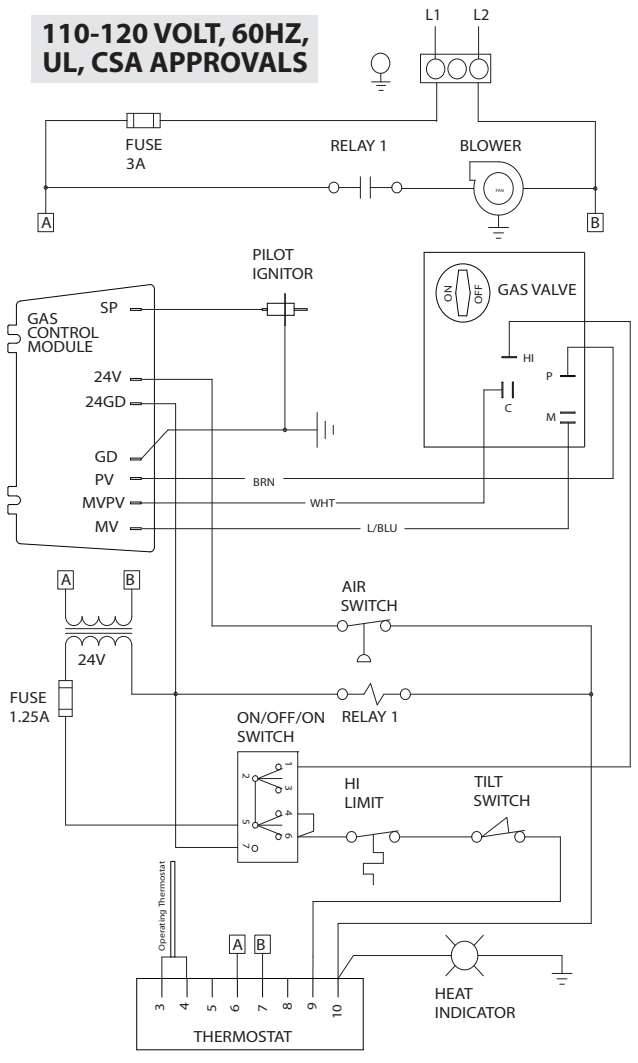

POWER TILT OPTION

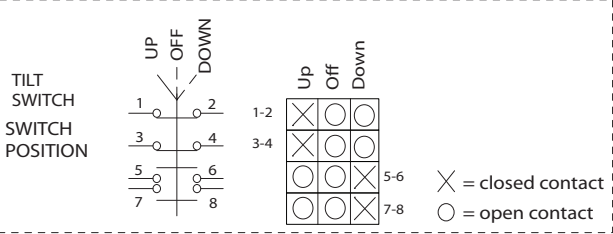
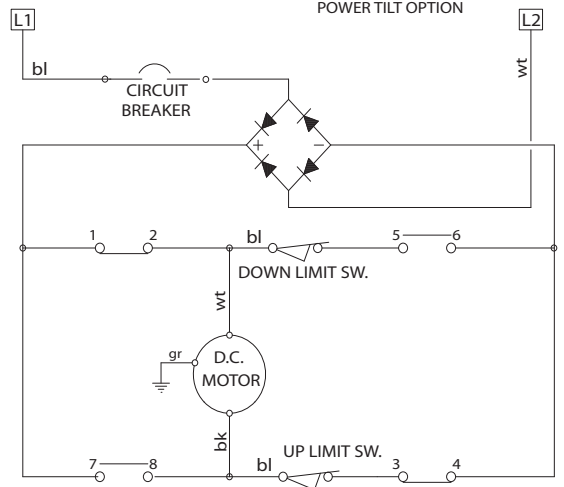

SK90125-9 Rev. A

# WIRING DIAGRAMS

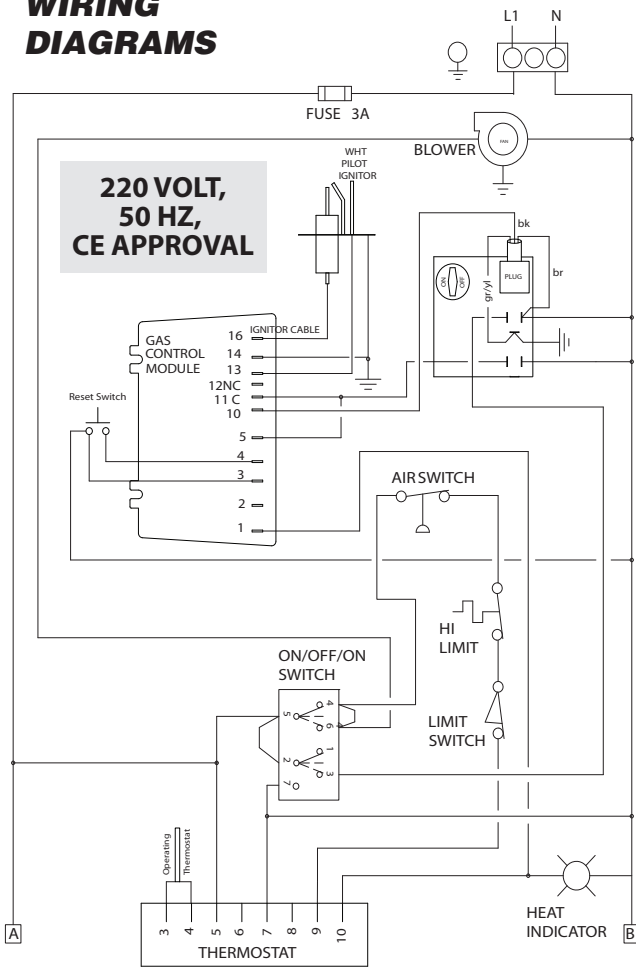

**220 VOLT,  
50 HZ,  
CE APPROVAL**

POWER TILT OPTION

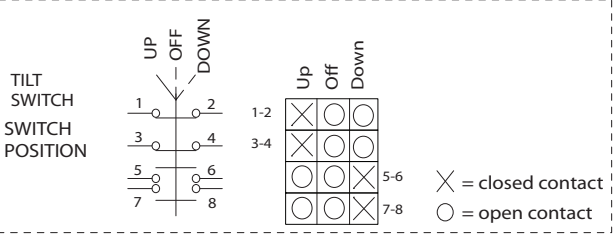
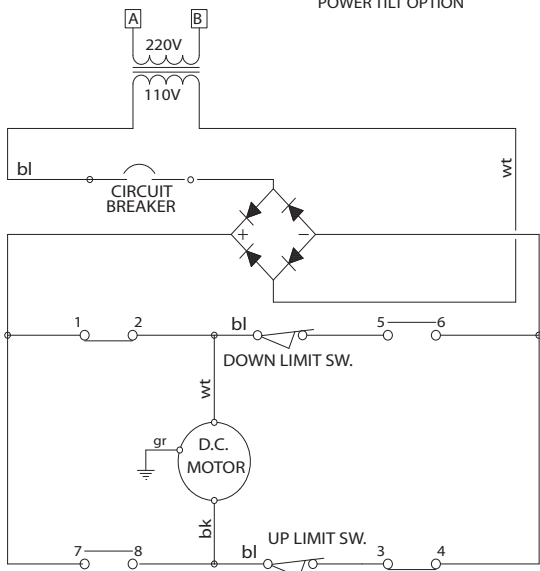

SK90125-8 REV. A

**110-120 VOLT, 60HZ,  
UL, CSA APPROVALS**

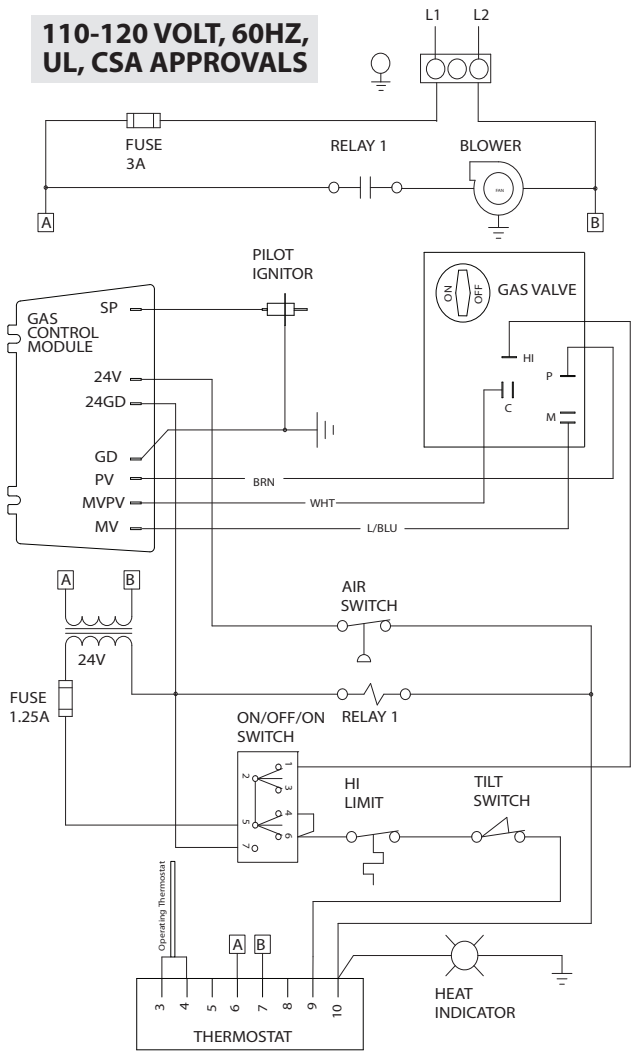

POWER TILT OPTION

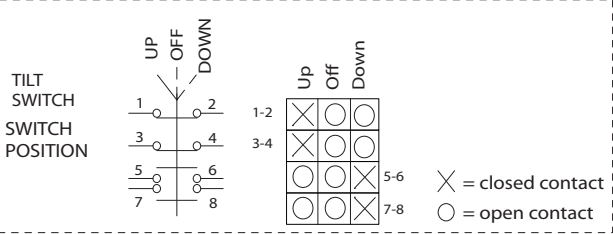
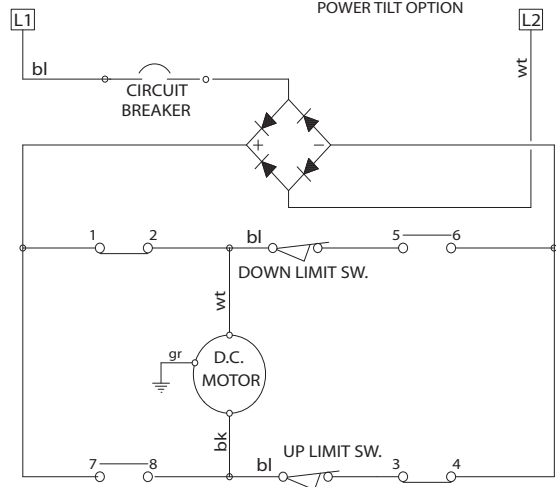

SK90125-9 Rev. A

# SERVICE PARTS

## WARRANTY

Our Company supports a worldwide network of Maintenance and Repair Centers. Contact your nearest Maintenance and Repair Centre for replacement parts, service, or information regarding the proper maintenance and repair of your cooking equipment.

In order to preserve the various agency safety certification (UL, NSF, ASME/Ntl. Bd., etc.), only factory-supplied replacement parts should be used. The use of other than factory supplied replacement parts will void warranty.

## TANGENT DRAW-OFF VALVES

### 1.5" & 3" TANGENT DRAW-OFF VALVE

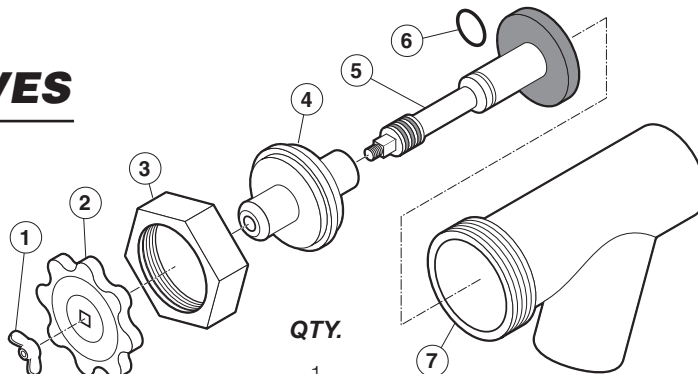

ITEM NO.	PART #	DESCRIPTION	QTY.
1. - 7.	KE50219	1.5" DRAW-OFF ASSEMBLY	1
	KE50973	3" DRAW-OFF ASSEMBLY	1
1.	SE50019	WING NUT, TD-1.5	1
	FA21501-1	ACCORN NUT, TD-3	1
	FA11511-1	SCREW (CORRECTIONAL PACKAGE)	1
	FA30505-1	WASHER (CORRECTIONAL PACKAGE)	1
2.	SE50017	KNOB, TD-1.5	1
	SE50018	KNOB, TD-3	1
3.	FI05180-3	HEX NUT, TD-1.5	1
	FI05180-2	HEX NUT, TD-3	1
4.	SE50011	RETAINER, TD-1.5	1
	SE50013	RETAINER, TD-3	1
5.	SE50008	PISTON, TD-1.5	1
	SE50010-1	PISTON, TD-3	1
	KE53290-4	PISTON, TD-3, MODIFIED (CORRECTIONAL PACKAGE)	1
6.	FA05002-24	"O" RING, TD-1.5	1
	FA05002-38	"O" RING, TD-3	1
7.	SE50005	VALVE BODY, TD-1.5	1
	KE50973	VALVE BODY, TD-3	1

### 2" TANGENT DRAW-OFF VALVE

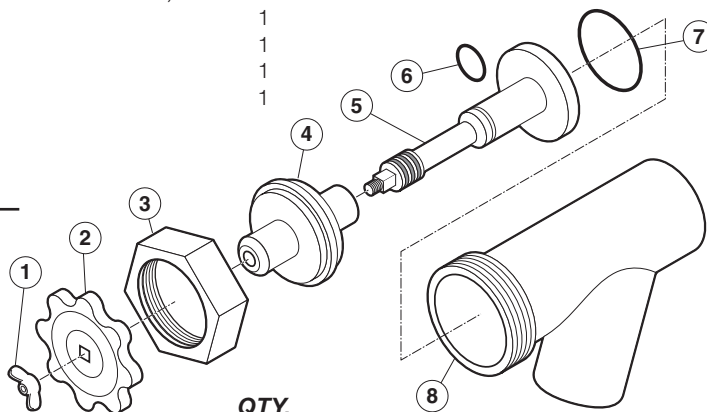

ITEM NO.	PART #	DESCRIPTION	QTY.
1. - 7.	KE50972-B	2" DRAW-OFF ASSEMBLY	1
1.	FA95049	WING NUT, TD-2	1
	FA511511-5	SCREW, TD-2 (CORRECTIONAL PACKAGE)	1
2.	KE52755	KNOB, TD-2	1
3.	FI05180-1	HEX NUT, TD-2	1
4.	KE52753	RETAINER, TD-2	1
5.	KE52752-1	PISTON, TD-2	1
	KE53290-3	PISTON, TD-2 (CORRECTIONAL PACKAGE)	1
6.	FA05002-24	"O" RING, BUNA-N (A-111), TD-2	1
7.	FA05002-55	"O" RING, VITON (AS568A-322), TD-2	1
8.	KE52751	VALVE BODY, TD-2	1

# FAUCETS

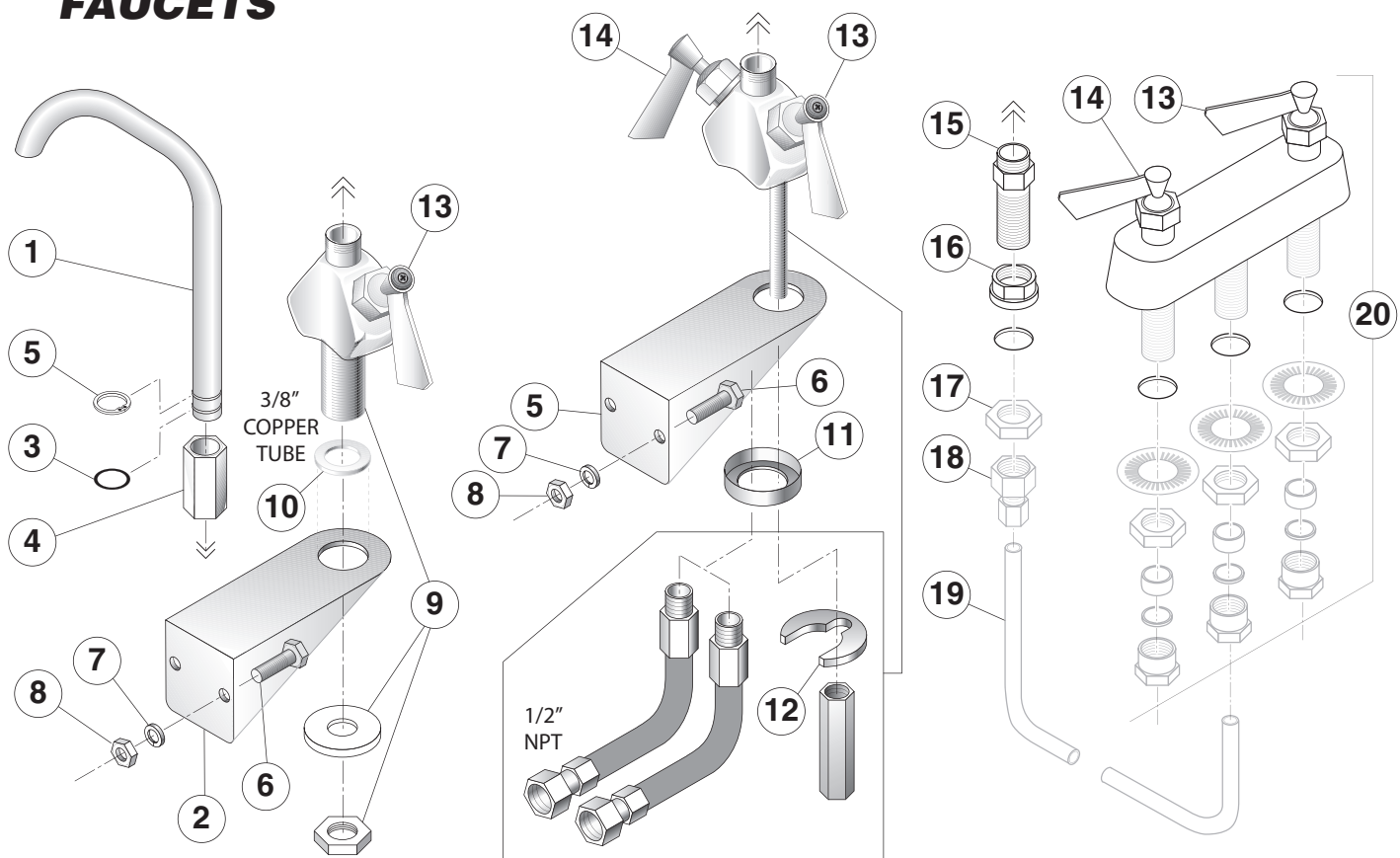

## Common Parts

ITEM #	PART #	DESCRIPTION	QTY.
	<b>SPK</b> _____	<b>SINGLE PANTRY FAUCET KIT</b> , (includes items 1-10) see page 2 for ordering information	
	<b>DPK</b> _____	<b>DOUBLE PANTRY FAUCET</b> , (includes items 1-8 & 11) see page 2 for ordering information	
1.	<a href="#">KE50825-</a> _____	<b>SPOUT</b> , see page 2 for ordering information	
2.	_____	<b>FAUCET MOUNTING BRACKET</b> , see page 2 for ordering information	1
3.	<a href="#">FA05002-19</a>	"O" RING	1
4.	<a href="#">KE51736</a>	LONG FAUCET NUT	1
5.	<a href="#">FA95007-10</a>	RETAINING RING	1
6.	<a href="#">FA11258</a>	HEX CAP SCREW	2
7.	<a href="#">FA31029</a>	LOCK WASHER	2
8.	<a href="#">FA21008</a>	HEX NUT	2
9.	<a href="#">KE51401</a>	SINGLE PANTRY BODY (c/w item 13)	1
10.	<a href="#">KE50335</a>	ADAPTER WASHER	1
11.	<a href="#">KE51403</a>	DOUBLE PANTRY BODY (c/w item 13 & 14)	1
12.	<a href="#">SE50447</a>	REPLACEMENT HORSESHOE WASHER	1
13.	<a href="#">SE50021</a>	REPLACEMENT STEM ASSEMBLY, COLD WATER	1
14.	<a href="#">SE50020</a>	REPLACEMENT STEM ASSEMBLY, HOT WATER	1
15.	<a href="#">SD50097</a>	FLANGED NUT, 3/4" NPT, CHROME PLATED	1
16.	<a href="#">KE51585</a>	FAUCET SPOUT FITTING	1
17.	<a href="#">SD50098</a>	LOCKNUT, 3/4" NPT	1
18.	<a href="#">FI00266</a>	COUPLING, 1/2" NPT	1
19.	<a href="#">SD50100</a>	COPPER TUBE	1
20.	<a href="#">KE51899</a>	REMOTE VALVE (c/w item 13 & 14)	1

# FAUCETS

## Models

	<b>FAUCET KIT</b>	<b>BRACKET</b>	<b>SPOUT</b>
KDT12/20 ON SD TABLE	SPK1 DPK1		KE50825-1
KDL60/80/100T KEL40/60/80/100T KET20 KGT,MKET, KDP60-100/T	SPK2 DPK2	KE54159 KE02071-1 (CP)	KE50825-2
KDL25/40T KEL25T,KDP25/40T	SPK3 DPK3	KE54159	KE50825-3
KDM60/T	SPK-KDM60 DPK-KDM60		KE50825-2
KDM25/40/T	SPK6 DPK6		KE50825-6
KDL40/60/80TSH KEL40/60TSH	SPK7 DPK7	KE54159	KE50825-7
KDT6 ON SD OR ST	SPK8 DPK8		KE50825-8
TKET, KET3/6/12	SPK9 DPK9	KE54159	KE50825-9
KDL125/150T KGL40/60/80T KGL40TSH	SPK10 DPK10	KE54159	KE50825-10
HAMKGL60/80/100T	SPK11 DPK11	KE54159	KE50825-11
KGL25T, T1	SPK13 DPK13	SK00395-1 KE02071-2 (CP)	KE50825-7
TR	SPK14 DPK14	SK2382300 SK2382400 (SPACER)	KE50825-6
SET10	DPK15 SPK15	SK2308800	KE50825-6
SET15	SPK16 DPK16	SK2302200	KE50825-6
HAMKGL60/80/100	DPK17 SKP17		KE50825-12
ALL STATIONARY KETTLES	DPK5 SPK5		KE50825-5

# FRAME / LID ASSEMBLY

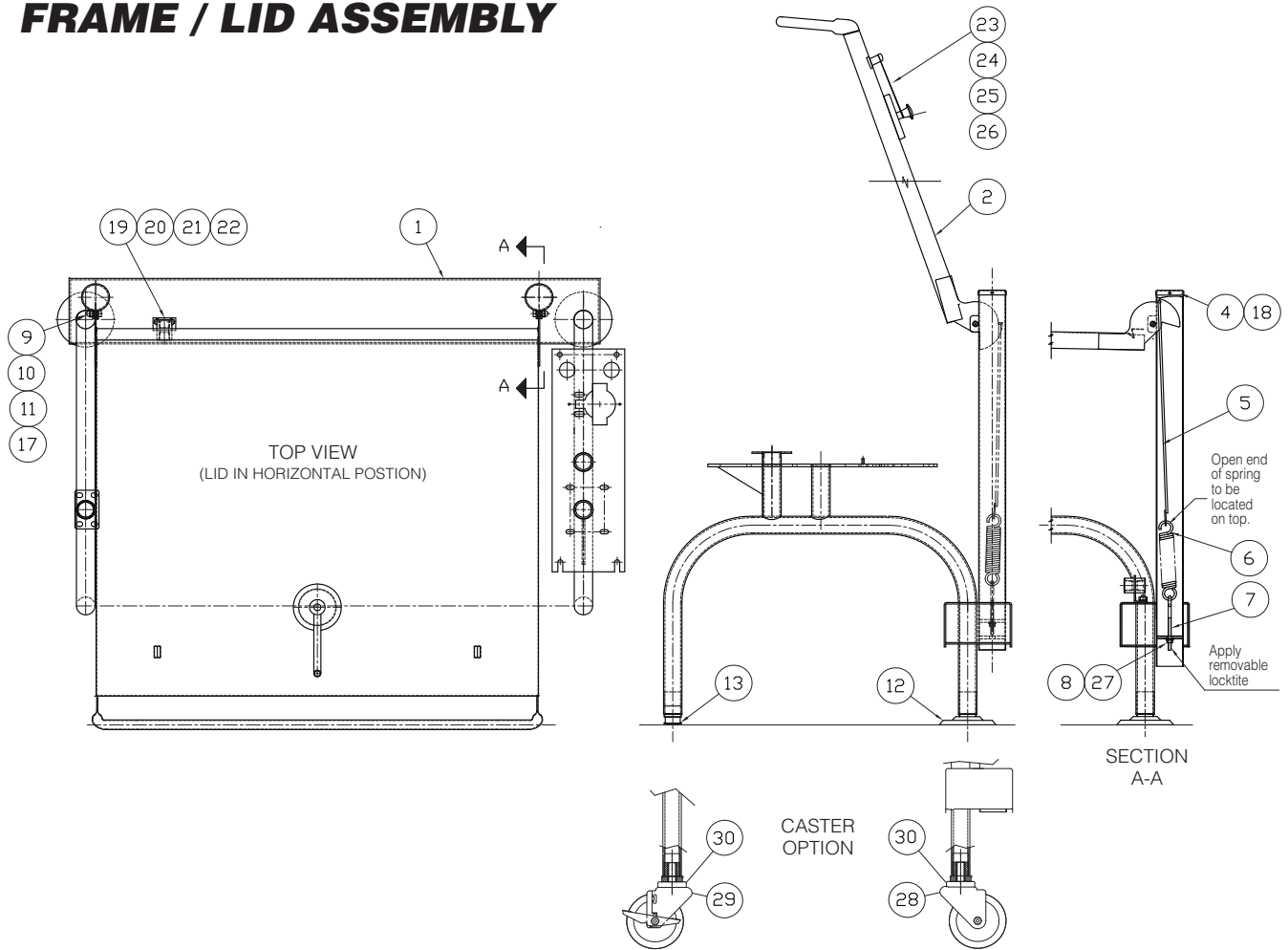

COMMON PARTS			
ITEM#	PART#		QTY
4	KE50187-1	CAP	2
5	SK00394-1	HOOK WELDMENT	2
6	SK2452300	SPRING	2
7	FA95087-1	EYE BOLT	2
8	FA20008	HEX NUT	2
9	KE53573-1	BEARING	2
10	FA15019-4	SHOULDER BOLT	2
11	FA21501-2	ACORN NUT	2
12	KE00099	ADJUSTABLE FOOT (FLANGE)	2
13	KE50249-2	FOOT ADJUSTOR (W/D FLANGE)	2
17	FA31029	LOCKWASHER	2
18	FA11054	SCREW	4
19	SK2459299	COUPLING ASSY	1
20	FA21024	HEX NUT (5/16-18)	2
21	FA31030	LOCKWASHER	2
22	FA30055	FLAT WASHER	2
23	SK00054	VENT COVER ASSY	1
24	SK2211200	SPACER	1
25	FA95081-1	BOLT, MODIFIED	1
26	SK50179	WASHER	1
27	FA30504	WASHER	2

SK00393-7 (SEL/SGL-30-T1)			
ITEM#	PART#	DESCRIPTION	QTY
1	SK00392-7	FRAME WELDMENT	1
2	SK2457192	LID ASSY	1

SK00393-8 (SGL-40-T1)			
ITEM#	PART#	DESCRIPTION	QTY
1	SK00392-8	FRAME WELDMENT	1
2	SK2457193	LID ASSY	1

SK00393-9 (SEL-40-T1)			
ITEM#	PART#	DESCRIPTION	QTY
1	SK00392-9	FRAME WELDMENT	1
2	SK2457193	LID ASSY	1

CASTER OPTION			
ITEM#	PART#	DESCRIPTION	QTY
28	KE53068-3	SWIVEL CASTER W/O BRAKE	2 2
29	KE53068-4	SWIVEL CASTER WITH BRAKE	2 2
30	KE53046-1	CASTER SLEEVE	4 4

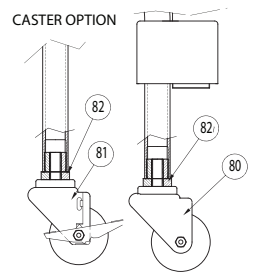
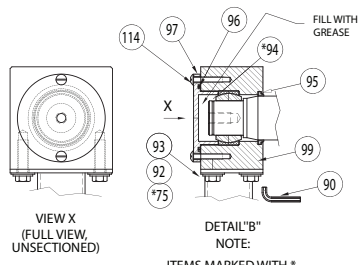
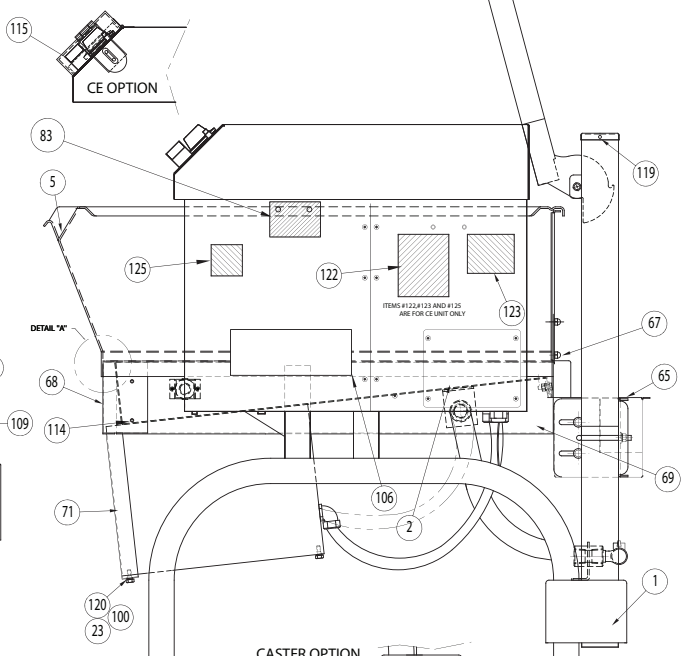
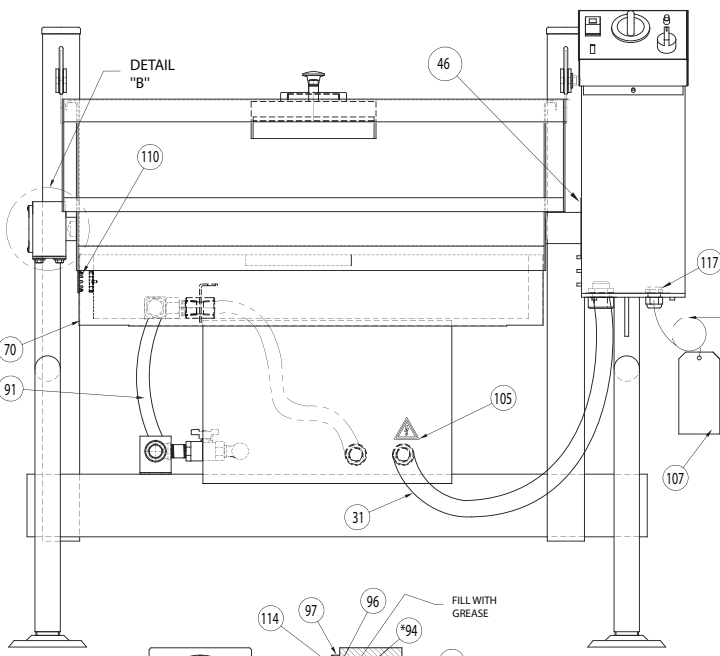
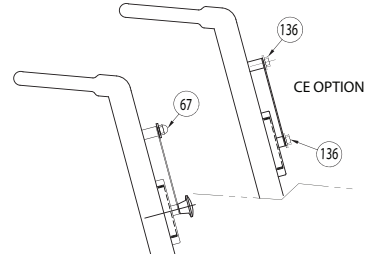
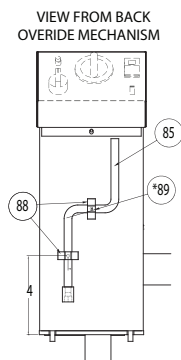
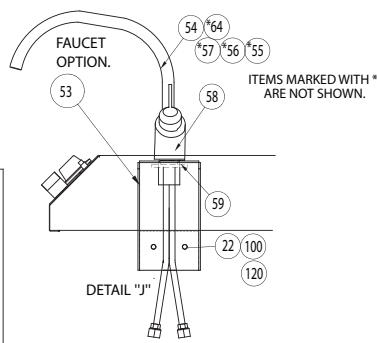
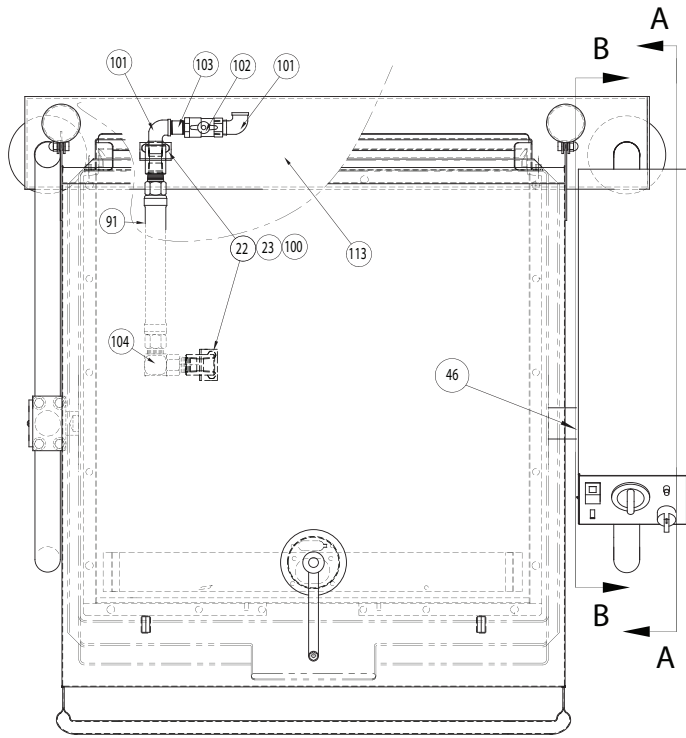

# GENERAL ASSEMBLY COMPONENTS

COMMON PARTS										
BILL OF MATERIALS										
KE003714-18		SGL-40-T1 CE OPTION LP GAS								▼
KE003714-17		SGL-30-T1 CE OPTION LP GAS								▼
KE003714-16		SGL-40-T1 LP GAS								▼
KE003714-15		SGL-30-T1 LP GAS								▼
KE003714-14		SGL-40-T1 CE OPTION NATURAL GAS								▼
KE003714-13		SGL-30-T1 CE OPTION NATURAL GAS								▼
KE003714-12		SGL-40-T1 NATURAL GAS								▼
KE003714-11		SGL-30-T1 NATURAL GAS								▼
ITEM	PART#	DESCRIPTION	QTY	QTY	QTY	QTY	QTY	QTY	QTY	QTY
1	SK00393-7	FRAME ASSEMBLY	1	-	1	-	1	-	1	-
	SK00393-8	FRAME ASSEMBLY	-	1	-	1	-	1	-	1
	SK00388-1	BURNER UNIT ASSEMBLY, 30 GAL. NAT. GAS.	1	-	-	-	-	-	-	-
	SK00388-2	BURNER UNIT ASSEMBLY, 40 GAL. NAT. GAS.	-	1	-	-	-	-	-	-
	SK00388-3	BURNER UNIT ASSEMBLY, 30 GAL. LP.	-	-	-	-	1	-	-	-
	SK00388-4	BURNER UNIT ASSEMBLY, 40 GAL. LP.	-	-	-	-	-	1	-	-
	SK00388-5	CE BURNER UNIT ASSEMBLY, 30 GAL. NAT. GAS.	-	-	1	-	-	-	-	-
	SK00388-6	CE BURNER UNIT ASSEMBLY, 40 GAL. NAT. GAS.	-	-	-	1	-	-	-	-
	SK00388-7	CE BURNER UNIT ASSEMBLY, 30 GAL. LP.	-	-	-	-	-	-	1	-
	SK00388-8	CE BURNER UNIT ASSEMBLY, 40 GAL. LP.	-	-	-	-	-	-	-	1
5	SK00385-7	PAN WELDMENT; NO TD VALVE	1	-	1	-	1	-	1	-
	SK00385-8	PAN WELDMENT; LH TD VALVE	-	1	-	1	-	1	-	1
	SK00386-7	PAN WELDMENT; NO TD VALVE	-	1	-	1	-	1	-	1
	SK00386-8	PAN WELDMENT; LH TD VALVE	-	1	-	1	-	1	-	1
11	FA95055-16	KEY 8mm X 8mm X 107mm	1	1	1	1	1	1	1	1
12	FA15019-7	SHOULDER BOLT	1	1	1	1	1	1	1	1
13	FA21008	1/4-20 HEX NUT, 18-8 S.S.	3	3	3	3	3	3	3	3
17	FA11325	HEX. CAP SCREW 5/16-18 X 1-1/4" S.S.	4	4	4	4	4	4	4	4
18	FA31030	5/16 SPLIT LOCKWASHER 5/16 S.S.	9	9	9	9	9	9	9	9
19	FA21024	NUT, 5/16-18 S.S. 18-8	8	8	8	8	8	8	8	8
23	FA31029	SPLIT LOCKWASHER 1/4	3	3	3	3	3	3	3	3
24	FA11286	SHCS 1/4-20 X 3/4" LONG S.S.	2	2	2	2	2	2	2	2
26	KE600284-6	GASKET, SILICONE GRAY	1	1	1	1	1	1	1	1
31	WHSGLT1	HARNESS FOR SGL T1	1	1	1	1	1	1	1	1
46	KE51084-2	WASHER	1	1	1	1	1	1	1	1
65	KE002486-1	FLUE DEFLECTOR ASSEMBLY	1	-	1	-	1	-	1	-
	KE002486-2	FLUE DEFLECTOR ASSEMBLY	-	1	-	1	-	1	-	1
67	FA21501-2	ACORN NUT 1/4-20, S.S.	4	4	4	4	4	4	4	4
68	SK50942-1	FRONT COVER	1	-	1	-	1	-	1	-
	SK50942-2	FRONT COVER	-	1	-	1	-	1	-	1
69	SK50943-1	SIDE COVER, R.H.	1	1	1	1	1	1	1	1
70	SK50943-2	SIDE COVER, L.H.	1	1	1	1	1	1	1	1
71	SK50946-1	FRONT BOX COVER	1	1	1	1	1	1	1	1
72	SK50918-1	COVER FOR SAFETY THERMOSTAT	1	1	1	1	1	1	1	1
73	SK50940	THERMOCOUPLE INSULATION	2	2	2	2	2	2	2	2
74	SK50932-1	BRACKET FOR THERMOCOUPLE	1	1	1	1	1	1	1	1
91	SK2472701	GAS CONNECTOR HOSE	1	1	1	1	1	1	1	1
92	KE55445	WASHER, HIGH STRENGTH ULTRA-COATED	4	4	4	4	4	4	4	4
93	FA31031	SPLIT LOCK WASHER, S.S., Ø3/8	4	4	4	4	4	4	4	4
94	FA95007-12	RETAINING RING, Ø1 3/16	1	1	1	1	1	1	1	1
95	KE55440	WIPER SEAL	1	1	1	1	1	1	1	1
96	FA05002-47	O-RING, Ø2 X Ø2 3/16	1	1	1	1	1	1	1	1
97	KE55446	PLATE, BEARING RETAINING	1	1	1	1	1	1	1	1
99	KE02383	HOUSING ASSEMBLY, TRUNNION	1	1	1	1	1	1	1	1
100	FA30505-1	FLAT WASHER 1/4	9	9	9	9	9	9	9	9
101	FI00134	ELBOW	2	2	2	2	2	2	2	2
102	F01518-1	SHUT OFF VALVE	1	1	1	1	1	1	1	1
103	N0640C2	NIPPLE	1	1	1	1	1	1	1	1
104	SK2472702	SWIVEL CONNECTOR	1	1	1	1	1	1	1	1
105	KE95497	RISK OF ELECTRIC SYMBOL	1	1	1	1	1	1	1	1
106	KE95552	LABEL, GAS RATING	1	1	-	-	1	-	1	-
	KE95552-2	LABEL, GAS RATING	-	-	1	-	-	1	-	-
107	KE95533-9	TAG	1	1	1	1	1	1	1	1
109	KE54821-8	ELECTRIC CORD	1	1	1	1	1	1	1	1
110	KE54907-16	PLUG BUTTON	1	1	1	1	1	1	1	1
112	SK2496600	WARNING LABEL	1	1	-	-	1	-	1	-
117	SK2147402	FITTING; LIQUID TIGHT	1	1	1	1	1	1	1	1
122	KE95476-2	GAS LABEL	-	-	-	-	1	-	-	-
	KE95476-3	GAS LABEL	-	-	1	-	-	-	1	-
123	KE95468-2	CONTAINER LABEL	-	-	1	1	-	-	1	1
125	S111900	LABEL; ELECTRICAL EQUIPMENT DISPOSAL	-	-	1	1	-	-	1	1
133	FA10772	3/8-16 X 1 1/2 HEX BOLT	1	1	1	1	1	1	1	1
134	FA21026	3/8-16 HEX NUT, S.S.	2	2	2	2	2	2	2	2
141	KE602239-4	STOP ARM	1	1	1	1	1	1	1	1
142	FA95052-9	THREADED ROD 3/8-16UNC x 4 5/8" LG.	1	1	1	1	1	1	1	1

OPTION PARTS										
BILL OF MATERIALS										
KE003714-18		SGL-40-T1 CE OPTION LP GAS								▼
KE003714-17		SGL-30-T1 CE OPTION LP GAS								▼
KE003714-16		SGL-40-T1 LP GAS								▼
KE003714-15		SGL-30-T1 LP GAS								▼
KE003714-14		SGL-40-T1 CE OPTION NATURAL GAS								▼
KE003714-13		SGL-30-T1 CE OPTION NATURAL GAS								▼
KE003714-12		SGL-40-T1 NATURAL GAS								▼
KE003714-11		SGL-30-T1 NATURAL GAS								▼
ITEM	PART#	DESCRIPTION	QTY	QTY	QTY	QTY	QTY	QTY	QTY	QTY
NO FAUCET OPTION										
83	KE95447	LABEL; TO COVER FAUCET MTG. HOLES	1	1	1	1	1	1	1	1
FAUCET OPTION (COMMON PARTS)										
22	FA21008	HEX. NUT 1/4-20	2	2	2	2	2	2	2	2
23	FA31029	SPLIT LOCKWASHER 1/4	2	2	2	2	2	2	2	2
53	SK00395-1	FAUCET BRACKET WELDMENT	1	1	1	1	1	1	1	1
54	KE50825-7	FAUCET SPOUT	1	1	1	1	1	1	1	1
55	FA95007-10	RETAINING RING	1	1	1	1	1	1	1	1
56	FA05002-19	O-RING	1	1	1	1	1	1	1	1
57	KE51736	FAUCET NUT	1	1	1	1	1	1	1	1
100	FA30505-1	FLAT WASHER 1/4	4	4	4	4	4	4	4	4
120	FA11258	1/4-20 X 3/4 HEX HEAD CAP SCREW	2	2	2	2	2	2	2	2
SINGLE PANTRY FAUCET OPTION										
58	KE51401	SINGLE PANTRY FAUCET BODY	1	1	1	1	1	1	1	1
59	KE50335	ADAPTER WASHER	1	1	1	1	1	1	1	1
DOUBLE PANTRY FAUCET OPTION										
58	KE51403	DOUBLE PANTRY FAUCET BODY	1	1	1	1	1	1	1	1
PRE-RINSE SPRAY HEAD										
64	PRSS-T1	PRE-RINSE SPRAY HEAD	1	1	1	1	1	1	1	1
SINGLE PANTRY FILLER										
64	SKFS-T1	SINGLE PANTRY FAUCET FILLER	1	1	1	1	1	1	1	1
DOUBLE PANTRY FILLER										
64	DKFS-T1	DOUBLE PANTRY FAUCET FILLER	1	1	1	1	1	1	1	1
PAN CARRIER OPTION.										
66	SK2499999	PAN CARRIER ASSEMBLY	-	1	-	1	-	1	-	1
POURING LIP STRAINER OPTION										
*78	SK2390802	STRAINER FOR POUR LIP	1	1	1	1	1	1	1	1
TD VALVE STRAINER OPTION										
*78	SK2390803	STRAINER FOR TD VALVE	1	1	1	1	1	1	1	1
FBS-F-T1										
53	SK00395-2	FAUCET BRACKET, FRANCE	1	1	1	1	1	1	1	1
FLANGED FEET OR CASTER MOUNT OPTIONS										
CASTER MOUNT OPTION										
80	KE53068-3	SWIVEL CASTER W/O BRAKE	2	2	2	2	2	2	2	2
81	KE53068-4	SWIVEL CASTER WITH BRAKE	2	2	2	2	2	2	2	2
82	KE53046-1	CASTER SLEEVE	4	4	4	4	4	4	4	4
113	KE55407	EQUIPMENT INSTALLATION LABEL	1	1	1	1	1	1	1	1
FLANGED FEET OPTION										
80	KE00099	FOOT ASSY; FORMED FLANGE	2	2	2	2	2	2	2	2
81	KE50249-2	ADJUSTOR; FLANGED FOOT	2	2	2	2	2	2	2	2
NO CP OPTION										
67	FA21501-2	ACORN NUT 1/4-20, S.S.	1	1	1	1	1	1	1	1
75	KE55443	CAP SCREW, 3/8-16, HIGH STRENGTH	4	4	4	4	4	4	4	4
114	F182	10-32 X 1/2 SLOTTED HEAD S.S. SCREW	8	8	8	8	8	8	8	8
116	FA11145	10-32 X 3/8 PAN HEAD TORX SCREW	2	2	2	2	2	2	2	2
119	FA11054	6-32 X 3/8 S.S. MACHINE SCREW	2	2	2	2	2	2	2	2
120	FA11511-11	1/4-20 X 3/4 PAN HEAD TORX SCREW	2	2	2	2	2	2	2	2
121	KE602946	PLUG (MANUAL TILT ONLY)	1	1	1	1	1	1	1	1
135	FA11511-1	1/4-20 X 1/2 PAN HEAD TORX SCREW	2	2	2	2	2	2	2	2
136	FA20502	1/4-20 18-8SS; NUT- SERRATED-FLANGE	2	2	2	2	2	2	2	2

## Safety Thermostat Installation Procedure (Detail A)

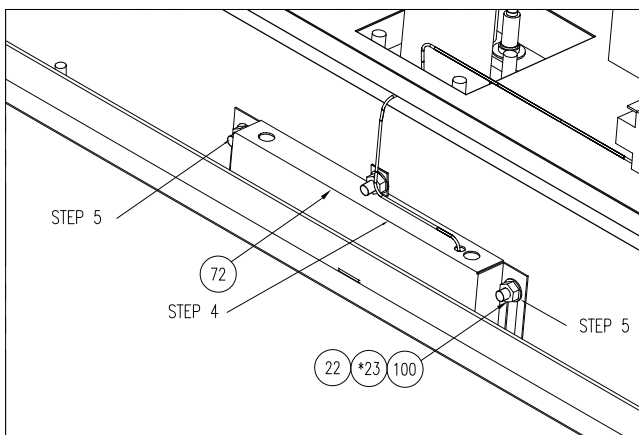
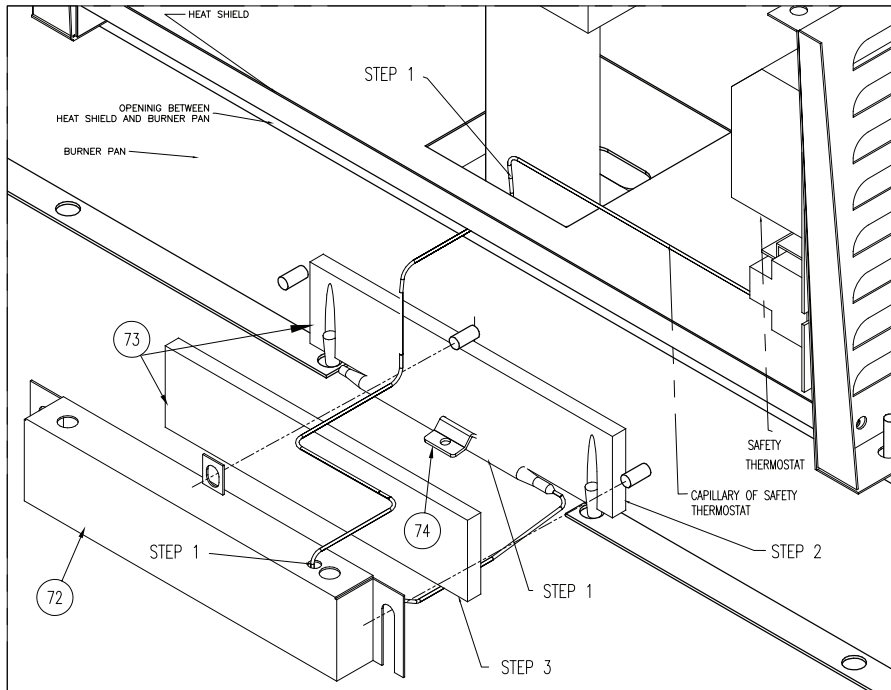

- STEP 1: - RUN CAPILLARY OF SAFETY THERMOSTAT THROUGH OPENING BETWEEN HEAT SHIELD AND BURNER PAN  
 - RUN CAPILLARY OF SAFETY THERMOSTAT THROUGH HOLE OF COVER FOR SAFETY THERMOSTAT, ITEM # 72  
 - INSTALL THE BRACKET FOR THERMOSTAT ( ITEM # 74 ), INSURE THE BULB IS CENTRED BETWEEN FRONT STUDS.
- STEP 2: - INSTALL INSULATION ITEM # 73 BEHIND STUDS, PUSH INSULATION UP BEHIND BULB
- STEP 3: - INSTALL INSULATION ITEM # 73 IN FRONT OF STUDS.
- STEP 4: - INSTALL COVER FOR SAFETY THERMOSTAT ITEM # 72, PUSH INSULATION DOWN TIGHT AGAINST BURNER PAN AND AROUND BULB.
- STEP 5: - INSTALL NUTS & WASHERS AND TIGHTEN TO PULL COVER AGAINST FACE OF BURNER PAN AND SEAL WITH THE INSULATION UNDER ITS EDGES.

### POWER TILT

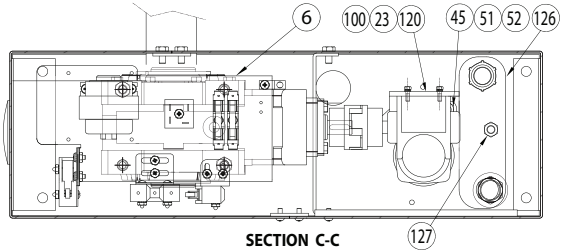

SECTION C-C

### MANUAL TILT OPTION

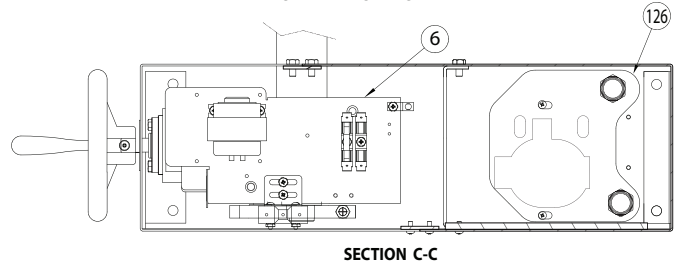

SECTION C-C

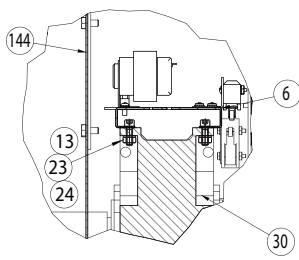

SECTION F-F

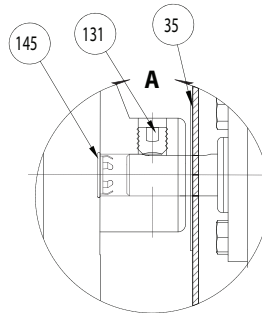

DETAIL A

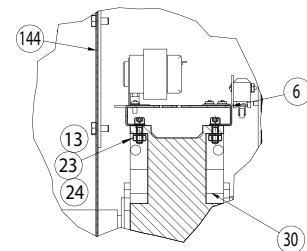

SECTION F-F

### 2 SIDES & BACK (26)

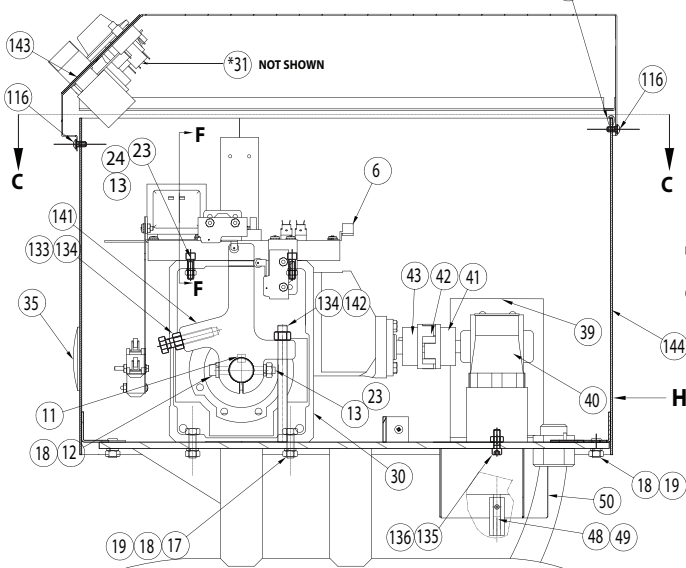

SECTION A-A

### 2 SIDES & BACK (26)

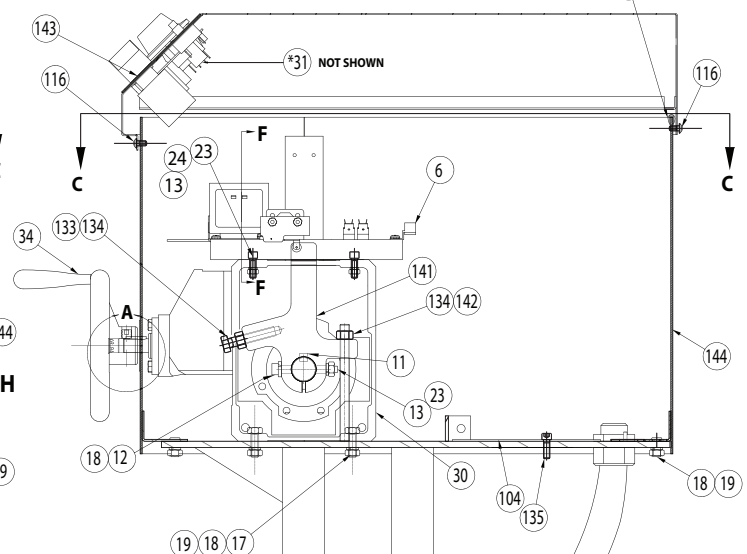

SECTION A-A

**POWER TILT**

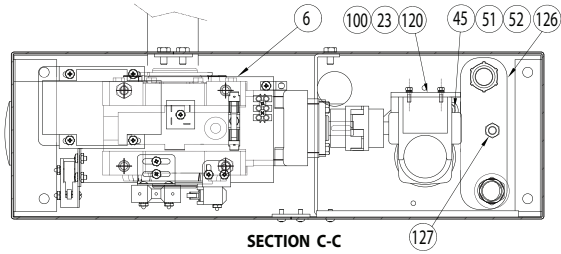

**MANUAL TILT**

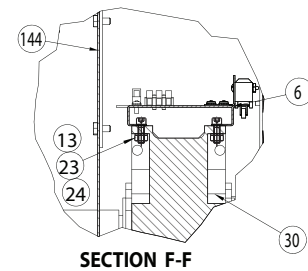
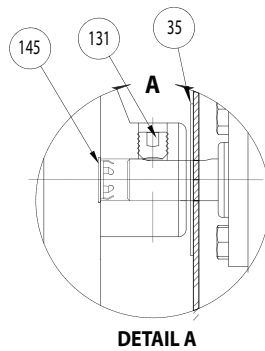
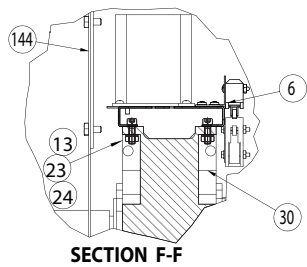
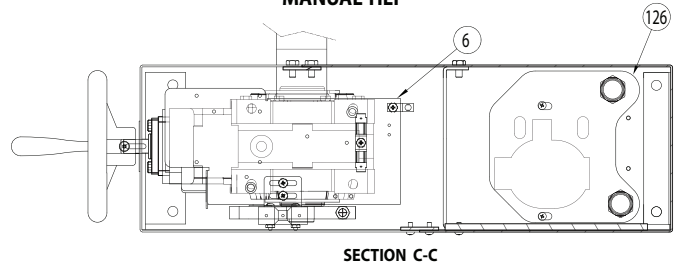

**2 SIDES & BACK**

**2 SIDES & BACK**

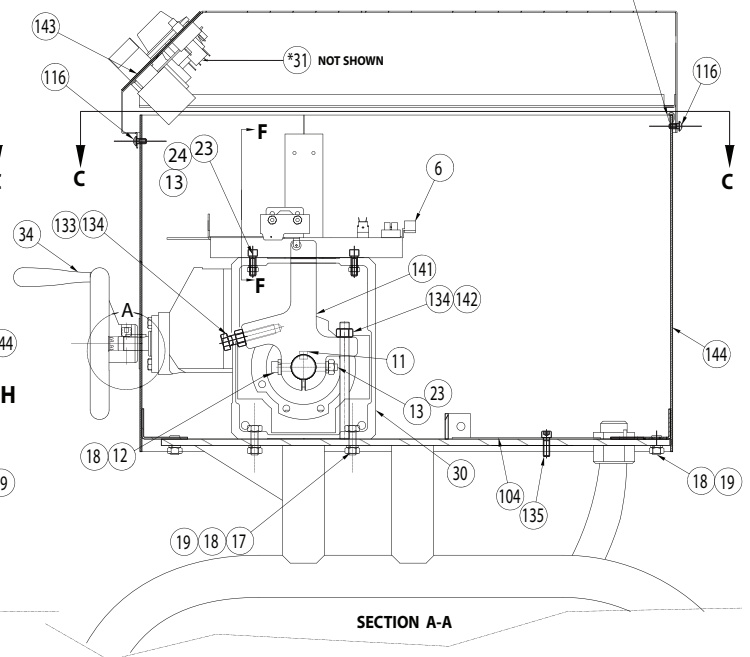
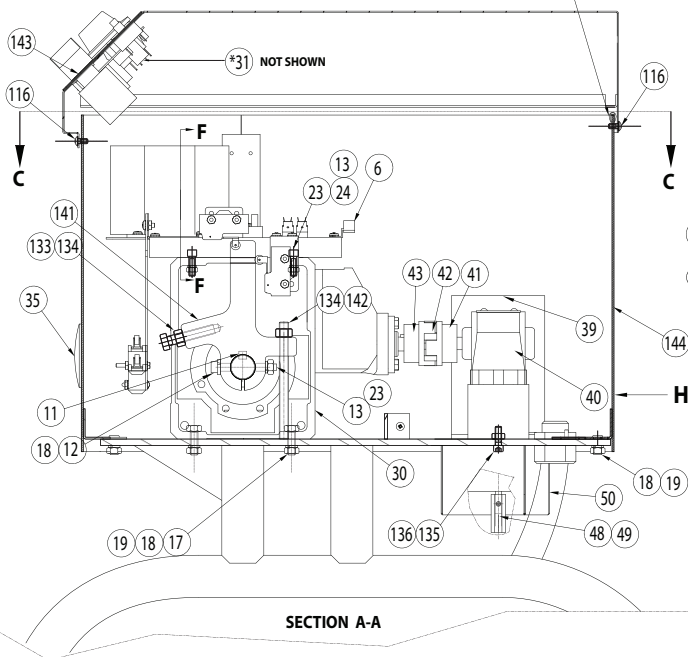

OPTION PARTS									
BILL OF MATERIALS									
KE003714-18	SGL-40-T1 CE OPTION LP GAS								▼
KE003714-17	SGL-30-T1 CE OPTION LP GAS								▼
KE003714-16	SGL-40-T1 LP GAS								▼
KE003714-15	SGL-30-T1 LP GAS								▼
KE003714-14	SGL-40-T1 CE OPTION NATURAL GAS								▼
KE003714-13	SGL-30-T1 CE OPTION NATURAL GAS								▼
KE003714-12	SGL-40-T1 NATURAL GAS								▼
KE003714-11	SGL-30-T1 NATURAL GAS								▼
ITEM	PART#	DESCRIPTION	QTY	QTY	QTY	QTY	QTY	QTY	QTY
MANUAL TILT OPTION 2 (SEE SHEET 3)									
6	KE003877-1	COMPONENT PLATE ASSY, MT, 110-120V							
	KE003877-3	COMPONENT PLATE ASSY, MT, 220-240 V, 60 Hz	1	1	-	-	1	1	-
	KE003877-5	COMPONENT PLATE ASSY, MT, 220-240 V, 50 Hz							
	KE003877-7	COMPONENT PLATE ASSY, MT, CE OPTION	-	-	1	1	-	-	1
30	KES5513-3	GEAR UNIT	1	1	1	1	1	1	1
34	KE603904-1	HAND WHEEL	1	1	1	1	1	1	1
35	KES4738-7	WASHER, FLAT	1	1	1	1	1	1	1
131	FA19505	SET SCREW 3/8-24 X 3/8	2	2	2	2	2	2	2
126	KE603929-1	BOTTOM PLATE MIT T1 SKILLET	1	1	1	1	1	1	1
143	SK00387-51	GEARBOX COVER ASSY; SGL-T1, MT °F OPTION; 110-120V			-	-			-
	SK00387-52	GEARBOX COVER ASSY; SGL-T1, MT °C OPTION; 110-120V	1	1	-	-	1	1	-
	SK00387-59	GEARBOX COVER ASSY; SGL-T1, MT °F OPTION; 220-240V			-	-			-
	SK00387-60	GEARBOX COVER ASSY; SGL-T1, MT °C OPTION; 220-240V			-	-			-
	SK00387-63	GEARBOX COVER ASSY; SGL-T1, MANUAL TILT °C OPTION	-	-	1	1	-	-	1
144	KE002590-6	WRAP WELDMENT FOR GEAR	1	1	1	1	1	1	1
145	KES4907-22	PLUG BUTTON	1	1	1	1	1	1	1

OPTION PARTS									
BILL OF MATERIALS									
KE003714-18	SGL-40-T1 CE OPTION LP GAS								▼
KE003714-17	SGL-30-T1 CE OPTION LP GAS								▼
KE003714-16	SGL-40-T1 LP GAS								▼
KE003714-15	SGL-30-T1 LP GAS								▼
KE003714-14	SGL-40-T1 CE OPTION NATURAL GAS								▼
KE003714-13	SGL-30-T1 CE OPTION NATURAL GAS								▼
KE003714-12	SGL-40-T1 NATURAL GAS								▼
KE003714-11	SGL-30-T1 NATURAL GAS								▼
ITEM	PART#	DESCRIPTION	QTY	QTY	QTY	QTY	QTY	QTY	QTY
POWER TILT (SEE SHEET 3)									
6	KE003877-2	COMPONENT PLATE ASSY, PT, 110-120 V							
	KE003877-4	COMPONENT PLATE ASSY, PT, 220-240 V, 60 Hz	1	1	-	-	1	1	-
	KE003877-6	COMPONENT PLATE ASSY, PT, 220-240 V, 50 Hz							
	KE003877-8	COMPONENT PLATE ASSY, PT, CE OPTION	-	-	1	1	-	-	1
16	FA31030	SPLIT LOCKWASHER 5/16 S.S.	1	1	1	1	1	1	1
23	FA31029	SPLIT LOCKWASHER 1/4	4	4	4	4	4	4	4
29	WHST1-PTA	POWER TILT HARNESS FOR T1	1	1	1	1	1	1	1
30	KES5513-3	GEAR UNIT	1	1	1	1	1	1	1
35	KES4907-16	PLUG BUTTON	1	1	1	1	1	1	1
39	KE601725-2	SUPPORT	1	1	1	1	1	1	1
40	KES2832-5	MOTOR, POWER TILT	1	1	1	1	1	1	1
41	KE0582-5	COUPLING HUB, 1/2 BORE	1	1	1	1	1	1	1
42	KE50583-1	COUPLING SPIDER	1	1	1	1	1	1	1
43	KE0582-6	COUPLING HUB, 14mm BORE	1	1	1	1	1	1	1
45	FA11384	HEX. CAP SCREW 3/8-16 X 1"	2	2	2	2	2	2	2
48	KE602542	EXTENSION FOR SHAFT	1	1	1	1	1	1	1
49	KE602543	SOCKET SET SCREW, CONE POINT	1	1	1	1	1	1	1
50	KE602507-1	BOTTOM COVER	1	1	1	1	1	1	1
51	FA21026	3/8 HEXAGON NUT	2	2	2	2	2	2	2
52	FA31031	3/8 SPLIT LOCKWASHER S.S.	2	2	2	2	2	2	2
85	KE003160	HANDLE WELDMENT	1	1	1	1	1	1	1
88	SK2473800	SPRING CLIP	2	2	2	2	2	2	2
89	F10	SCREW: PAN QUAD8-32 X 3/8	2	2	2	2	2	2	2
100	FA30505-1	FLAT WASHER 1/4	4	4	4	4	4	4	4
101	FA11258	1/4-20 x 3/4 BOLT, 18-8 S.S.	4	4	4	4	4	4	4
126	KE603929-2	BOTTOM PLATE PT T1 SKILLET	1	1	1	1	1	1	1
127	FA21008	HEX NUT; 1/4-20 18-8 S/S	2	2	2	2	2	2	2
143	SK00387-53	GEARBOX COVER ASSY; SGL-T1, MT °F OPTION; 110-120 V			-	-			-
	SK00387-54	GEARBOX COVER ASSY; SGL-T1, MT °C OPTION; 110-120 V	1	1	-	-	1	1	-
	SK00387-61	GEARBOX COVER ASSY; SGL-T1, MT °F OPTION; 220-240 V			-	-			-
	SK00387-62	GEARBOX COVER ASSY; SGL-T1, MT °C OPTION; 220-240 V			-	-			-
SK00387-64	GEARBOX COVER ASSY; SGL-T1, MANUAL TILT °C OPTION	-	-	1	1	-	-	1	
144	KE002590-6	WRAP WELDMENT FOR GEAR	1	1	1	1	1	1	1

# CONTROL BOX ASSEMBLY

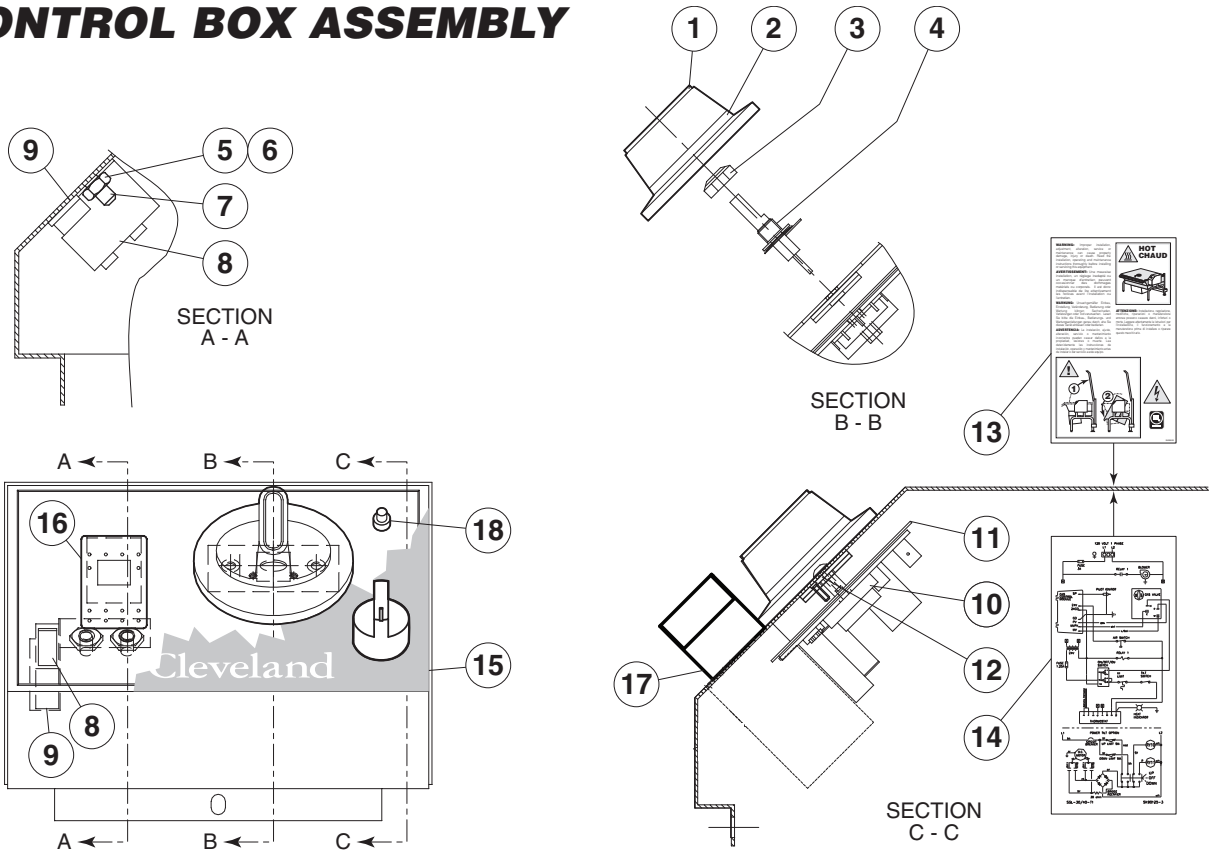

ITEM NO.	PART NO.	DESCRIPTION	QTY.
1.	SK2138700	KNOB ASSEMBLY	1
2.	SK2360700	DIAL INSERT °F	1
	SK2360701	DIAL INSERT °C	1
3.	KE51005	RUBBER BOOT. #N9030 X 1/4	1
4.	SK2498399	POTENTIOMETER SHAFT ASSEMBLY	1
INCLUDES	SK2166800	POTENTIOMETER SHAFT	1
	SK2167000	TENSION PIN	1
	SK2167100	WASHER, BOWED/SPRING	1
	SK2167200	RETAINING RING, SP-NR #R1000-25	1
	SK2167300	PANEL BEARING	1
	SK2382800	RETAINING RING CLIP	1
	5.	FA21006	NUT, S.S. F#10-24
6.	FA32022	TOOTH LOCK WASHER #10 S.S.	2
7.	FA40000-6	#10-24 X 3/8 S.S. WELD STUD	2
8.	SK50903-1	BRACKET, INDICATOR LIGHT	1
9.	SK50905-1	HEAT INDICATOR, 28V	1
10.	SK2142002	THERMOSTAT	1
11.	SK2159300	THERMOSTAT INSULATOR	1
12.	SK2491500	STOP PLATE ASSEMBLY	1
13.	SK95063	CAUTION LABEL	1
14.	SK90125-3	WIRING DIAGRAM	1
15.	KE95604-5	CONTROLS LABEL, MANUAL TILT	1
	KE95604-6	CONTROLS LABEL, POWER TILT	1
16.	SK2474102	SWITCH, ON/OFF/ON, DUAL FIRING	1
17.	SE003687	SWITCH ASSEMBLY REPLACEMENT KIT	1
INCLUDES	KE603208-4	SWITCH	1
	KE603208-7	LATCH	1
	KE603208-9	CONTACT	4
	KE603747	LABEL	2
	18.	KE50579-2	CIRCUIT BREAKER
	FA05002-34	"O" RING, CIRCUIT BREAKER	1
	KE50580	WATER RESISTANT BOOT	1

# SUPPORT PLATE ASSEMBLY

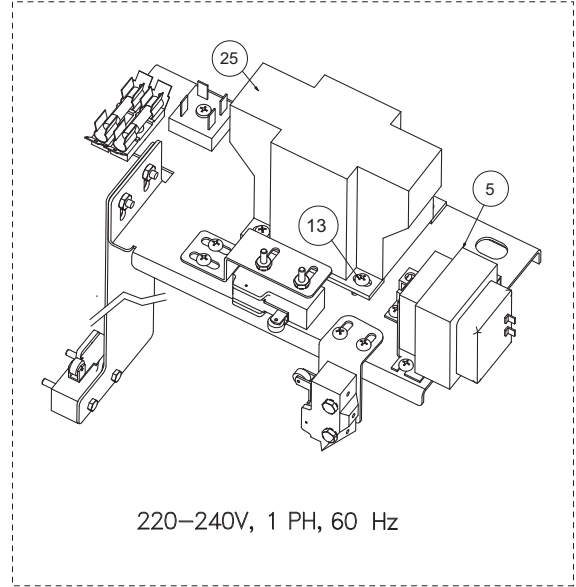
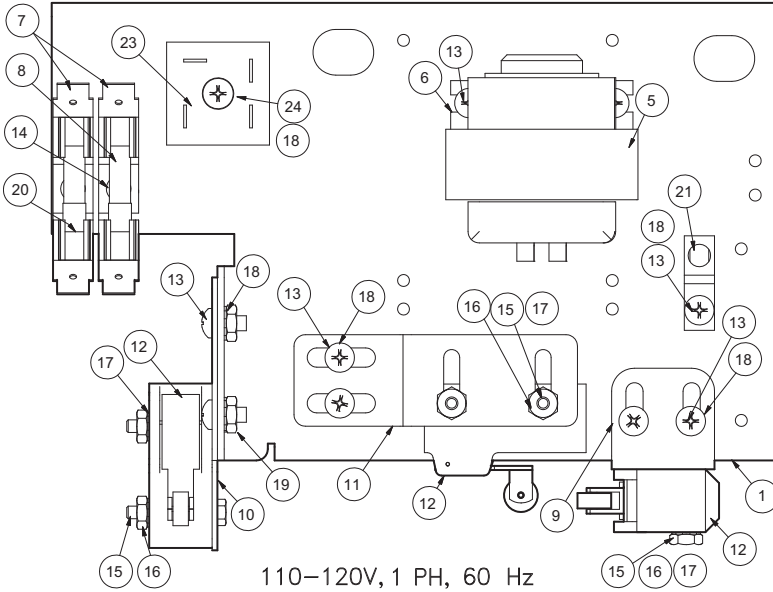

ITEM NO.	PART NO.	DESCRIPTION	QTY.
<b>COMMON PARTS:</b>			
1	KE602587-1	SUPPORT PLATE	.1
5	KE53838-25	TRANSFORMER	.1
6	KE53444	BRACKET, TRANSFORMER MOUNTING	.1
7	KE51139	FUSE HOLDER	.2
8	KE52936-6	FUSE 3.00 AMP, 250V	.1
11	KE602598-1	MOUNTING BRACKET; 5° TILT	.1
12	SK2474500	SWITCH, TILT LIMIT	.1/3
13	FA11091	#8-32 X 3/8 S.S. MACHINE SCREW	5/7/9/11
14	FA11054	#6-32 X 3/8 S.S. MACHINE SCREW	.9
15	FA11060	#6-32 X 1 S.S. MACHINE SCREW	.2
16	FA21002	#6-32 HEX MACHINE SCREW NUT S.S.	.9
17	FA32004	#6 EXTERNAL TOOTH LOCK WASHER	.4
18	FA32005	#8 EXTERNAL TOOTH LOCK WASHER	.1
20	KE52936-8	FUSE 1.25 AMP, 250V	.2
21	KE50473	GROUND LUG	.1
<b>110-120V, POWER TILT MODELS:</b>			
9	KE602573-1	BRACKET, LIMIT SWITCH MOUNTING	.1
10	KE602571	MOUNTING BRACKET: FULL TILT	.1
19	FA21004	#8-32 HEX MACHINE SCREW NUT S.S.	.2
23	KE50581	BRIDGE RECTIFIER	.1
24	FA15018-8	8-32 X 1 SEMS SCREW	.1
<b>220-240V, MANUAL TILT MODELS:</b>			
25	KE53838-10	TRANSFORMER	1
<b>20-240V, POWER TILT MODELS:</b>			
9	KE602573-1	BRACKET, LIMIT SWITCH MOUNTING	.1
10	KE602571	MOUNTING BRACKET: FULL TILT	.1
19	FA21004	#8-32 HEX MACHINE SCREW NUT S.S.	.2
23	KE50581	BRIDGE RECTIFIER	.1
24	FA15018-8	8-32 X 1 SEMS SCREW	.1
25	KE53838-10	TRANSFORMER	.1

# BURNER ASSEMBLY

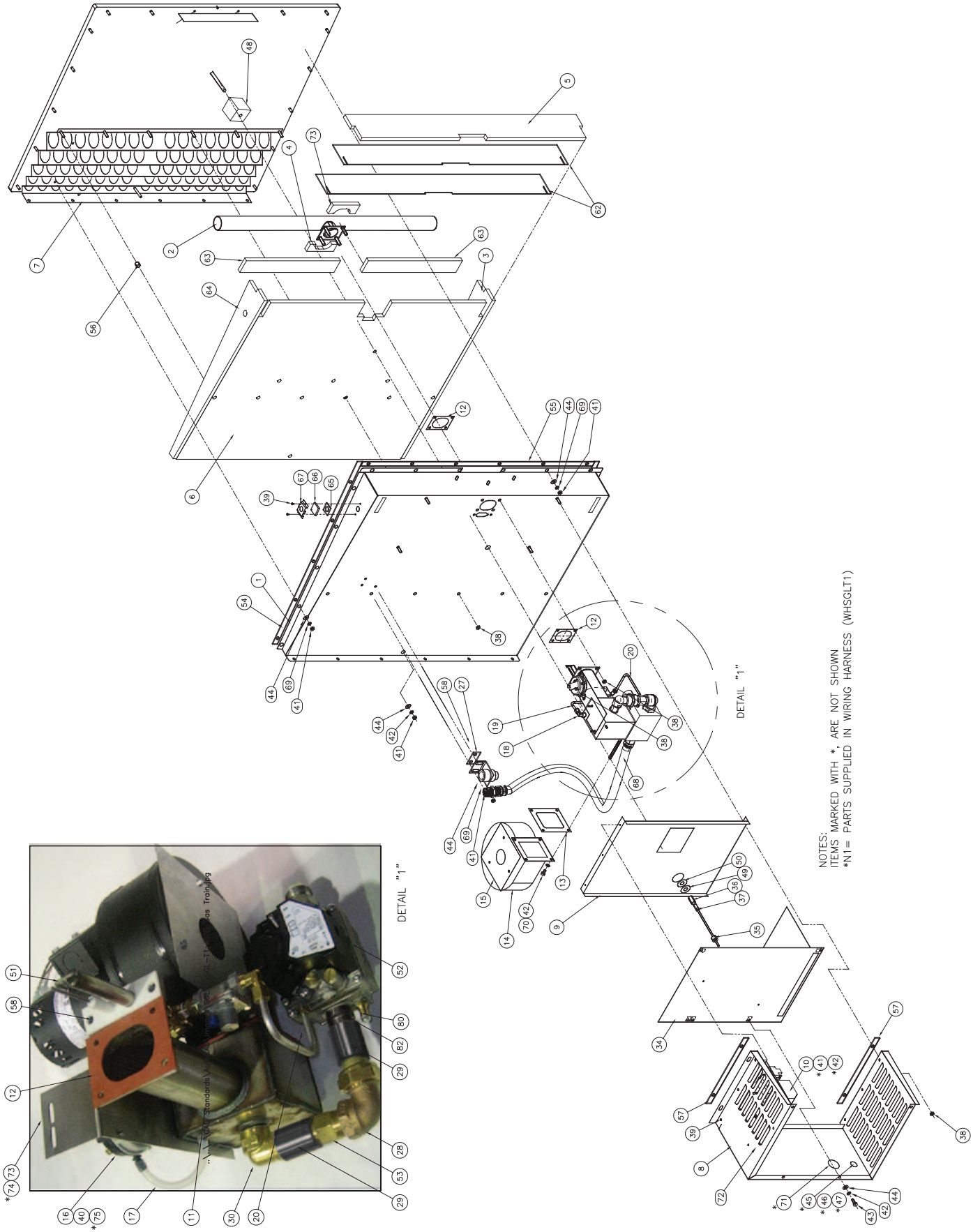

# BURNER ASSEMBLY

ITEM	PART#	DESCRIPTION	QTY	QTY	QTY	QTY	QTY
-	SK00388-4	BURNER UNIT ASSEMBLY, 40 GAL. LP.					▼
-	SK00388-3	BURNER UNIT ASSEMBLY, 30 GAL LP.					▼
-	SK00388-2	BURNER UNIT ASSEMBLY, 40 GAL. NAT. GAS					▼
-	SK00388-1	BURNER UNIT ASSEMBLY, 30 GAL NAT GAS					▼
43	FA11258	HEX. SCREW, 1/4-20 X 3/4	4	4	4	4	4
44	FA30505-1	WASHER, 1/4	21	23	21	23	23
45	SK50399	CONNECTOR 1/2 LIQUIDTIGHT	*N1	*N1	*N1	*N1	*N1
46	KE54617-1	CONNECTOR, 45 DEG. 1/2 TIGHT	*N1	*N1	*N1	*N1	*N1
47	KE51916-2	1/2 LIQUIDTIGHT	*N1	*N1	*N1	*N1	*N1
48	SK50941-1	PROBE INSULATION	1	-	1	-	-
.	SK50941-2	PROBE INSULATION	-	1	-	1	-
49	FA30505-3	WASHER	1	1	1	1	1
50	SK2460900	GASKET	1	1	1	1	1
51	SK00398-1	PILOT ASSEMBLY, NATURAL GAS	1	1	-	-	-
.	SK00398-2	PILOT ASSEMBLY, LP.	-	-	1	1	1
52	SK24882-1	STANDARD GAS VALVE FOR NATURAL GAS	1	1	-	-	-
.	SK24882-2	STANDARD GAS VALVE FOR LP	-	-	1	1	1
53	REF.KE55278	GAS ORIFICE.REF. TO DWG. FOR SELECTION	1	1	1	1	1
54	SK2472402	GASKET, PAN TO BURNER PAN ( SIDE)	2	2	4	4	4
55	SK2472400	GASKET, PAN TO BURNER PAN ( FRONT)	1	-	2	-	-
.	SK2472401	GASKET, PAN TO BURNER PAN ( FRONT)	-	1	-	2	-
56	SK2463800	SPACER	4	6	4	6	6
57	SK2461000	GASKET, COMPONENT MOUNTING	2	2	2	2	2
58	SK2498500	GASKET, GAS LINE MOUNT	1	1	1	1	1
62	SK600116-1	INSULATION BURNER, FRONT THIN	2	-	2	-	-
.	SK600116-2	INSULATION BURNER, FRONT THIN	-	2	-	2	-
63	SK600117-1	INSULATION UNDER BURNER	2	-	2	-	-
.	SK600117-2	INSULATION UNDER BURNER	-	2	-	2	-
64	KE600641-2	INSULATION, SIDE	1	1	1	1	1
65	KE53618	SIGHT GLASS GASKET	1	1	1	1	1
66	KE53617	SIGHT GLASS	1	1	1	1	1
67	KE53619	SIGHT GLASS RETAINER	1	1	1	1	1
68	KE603155	FLEXIBLE S.S. GAS HOSE	1	1	1	1	1
69	FA32008	TOOTH LOCK WASHER	14	16	14	16	16
70	FA11256	BOLT 1/4"-20, 1/2"	4	4	4	4	4
71	KE50555-7	GROMMET RUBBER	1	1	1	1	1
72	FA20504-3	10-24 LOCK NUT, ZINK COATED	1	1	1	1	1
73	KE602274	BRACKET, AIR SWITCH MOUNTING	1	1	1	1	1
74	SK2460701	INSULATION, BURNER/IGNITOR	1	1	1	1	1
75	FA11092	PAN HEAD PHILLIPS S.S. SCREW #8-32 X 1/2	2	2	2	2	2
80	G02251-1	GAS SP'GOT	1	1	1	1	1
82	N06400C1-5	NIPPLE 3/4 X 1 1/2 LG, BLACK PIPE	1	1	1	1	1

ITEM	PART#	DESCRIPTION	QTY	QTY	QTY	QTY	QTY
-	SK00388-4	BURNER UNIT ASSEMBLY, 40 GAL. LP.					▼
-	SK00388-3	BURNER UNIT ASSEMBLY, 30 GAL LP.					▼
-	SK00388-2	BURNER UNIT ASSEMBLY, 40 GAL. NAT. GAS					▼
-	SK00388-1	BURNER UNIT ASSEMBLY, 30 GAL NAT GAS					▼
1	SK00399-1	BURNER PAN ASSEMBLY	1	-	1	-	-
.	SK00399-1	BURNER PAN ASSEMBLY	-	1	-	1	-
2	SK2478801	BURNER ASSEMBLY	1	-	1	-	-
.	SK2478800	BURNER ASSEMBLY	-	1	-	1	-
3	KE600641-1	INSULATION, SIDE	1	1	1	1	1
4	SK2460700	INSULATION, BURNER/IGNITOR	1	1	1	1	1
5	SK2460500	INSULATION FRONT	1	-	1	-	-
.	SK2460400	INSULATION FRONT	-	1	-	1	-
6	SK50939-1	INSULATION BOTTOM	1	-	1	-	-
.	SK50919-1	INSULATION BOTTOM	-	1	-	1	-
7	SK2494999	BAFFLE ASSEMBLY	1	-	1	-	-
.	SK2471099	BAFFLE ASSEMBLY	-	1	-	1	-
8	SK00396-1	BOX ASSEMBLY	1	1	1	1	1
9	SK50927-1	HEAT SHIELD	1	1	1	1	1
10	SK00397-1	GAS IGNITION CONTROL ASSY (STANDARD SKILLETS).	1	1	1	1	1
11	KE02411	AIR MIX CHAMBER ASSEMBLY	1	1	1	1	1
12	SK2460000	GASKET: BURNER MOUNTING	2	2	2	2	2
13	SK2460200	GASKET: PAN MOUNTING	1	1	1	1	1
14	SK2476000	BLOWER FAN (STANDARD SKILLETS)	1	1	1	1	1
15	SK2480102	AIR ORIFICE: BLOWER	1	-	1	-	-
.	SK2480100	AIR ORIFICE: BLOWER	-	1	-	1	-
16	KE55453-1	AIR PRESSURE SWITCH	1	1	1	1	1
17	KE55501	TUBE, AIR SWITCH FLEXIBLE	1	1	1	1	1
18	FI05198-1	ELBOW; COMPRESSION 1/4 TUBEX1/8 MPT	1	1	1	1	1
19	SK2491200	1/4 TUBE AIR MIX - IGNITOR	1	1	1	1	1
20	SK24913-2	1/4 TUBING COMP; T1 GAS VALVE	1	1	1	1	1
27	SK2459299	COUPLING ASSEMBLY	1	1	1	1	1
28	SK076015-2	ELBOW: 3/4 UNION	1	1	1	1	1
29	SK076010-4	PIPE COUPLING - WS TYPE; 3/4	2	2	2	2	2
30	SK2489700	STREET ELBOW	1	1	1	1	1
34	SK2462899	COVER ASSEMBLY,GAS COMP.BOX	1	1	1	1	1
35	SK50933-1	OPERATING THERMOSTAT	1	1	1	1	1
36	SK2490600	COUPLING, 1/8 NPT SS	1	1	1	1	1
37	SK2487800	BAYONET, ADAPTOR	1	1	1	1	1
38	FA20502	FLANGED NUT	14	16	14	16	16
39	F10	THREAD-CUTTING SCREW, 8-32 X3/8"	8	8	8	8	8
40	F900	K-LOCK NUT, 10-24	3	3	3	3	3
41	FA21008	HEX. NUT, 1/4 -20 S.S.	23	25	23	25	25
42	FA31029	SPLIT LOCKWASHER, 1/4-S.S.	11	11	11	11	11

# GAS TRAIN, TRUNNION ASSEMBLIES

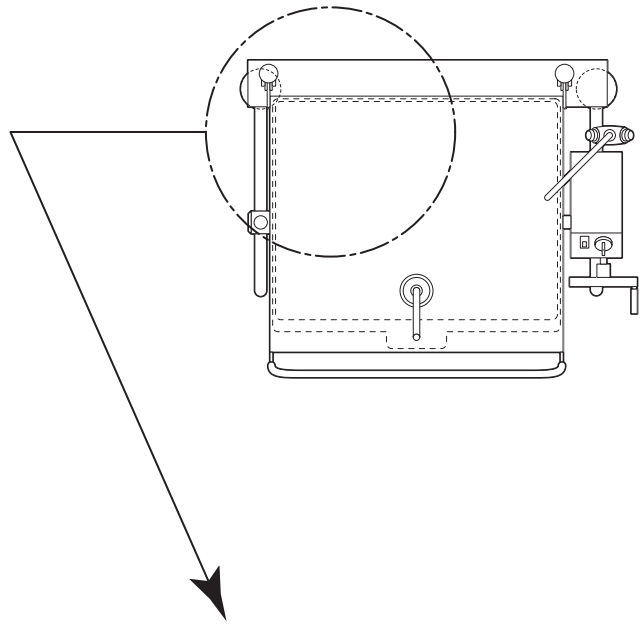

ITEM NO.	PART NO.	DESCRIPTION	QTY.
----------	----------	-------------	------

## GAS TRAIN

1.	FI00134	ELBOW .....	2
2.	F01518-1	SHUT OFF VALVE .....	1
3.	FI00607	NIPPLE .....	1
4.	SK2472702	SWIVEL CONNECTOR .....	1
5.	SK2472701	GAS CONNECTOR HOSE .....	1
6.	SK2459299	BRACKET ASSEMBLY, GAS LINE ...	1

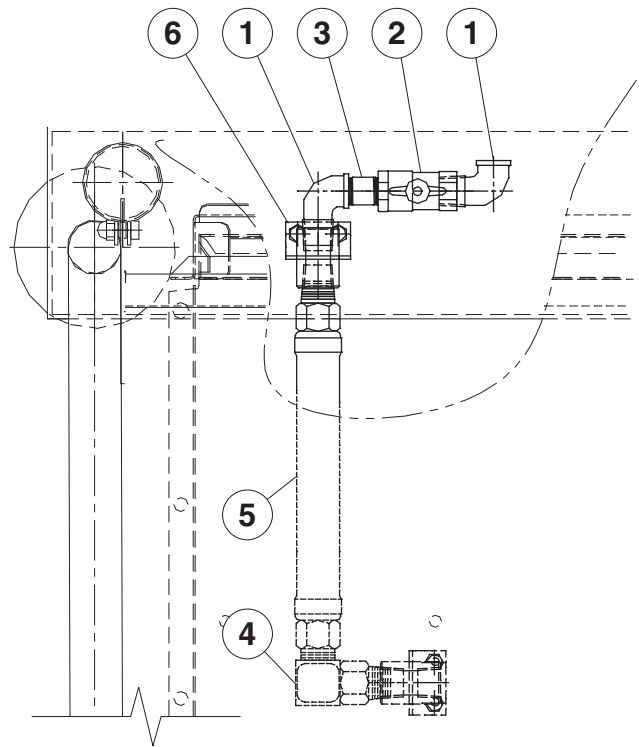

# PILOT ASSEMBLY

ITEM NO.	PART NO.	DESCRIPTION	QTY.
1	SK00398-1	PILOT ASSEMBLY, NATURAL GAS	1
	SK00398-2	PILOT ASSEMBLY, LP	1
2.	SK2460100	GASKET	1
3.	SK2477000	IGNITOR/PILOT ASSEMBLY	1
4.	SK2488300	GAS REGULATOR	1
5.	SK2489800	TEE, 1/8	1
6.	FI05198-1	ELBOW, 1/8	2
7.	SK2488400	VARIABLE ORIFICE NATURAL GAS	1
	SK2488401	VARIABLE ORIFICE PROPANE	1

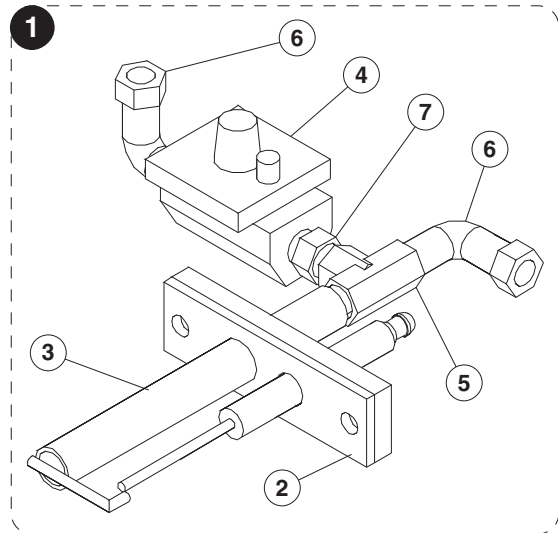

# GAS IGNITION CONTROL SYSTEM

ITEM NO.	PART NO.	DESCRIPTION	QTY.
1	SK00397-1	GAS IGNITION CONTROL ASSEMBLY	1
1.	SK50931-1	MOUNTING PLATE	1
2.	SK2475300	GAS CONTROL MODULE	1
4.	KE55069-7	HIGH LIMIT (INCLUDES MOUNTING BRACKET SK50931)	1
5.	FA12	SCREW, 10-24 X 3/8	8
6.	SK2475600	HOLDER	1
7.	SK2475500	RELAY	1
	SK2475700	SPRING	1

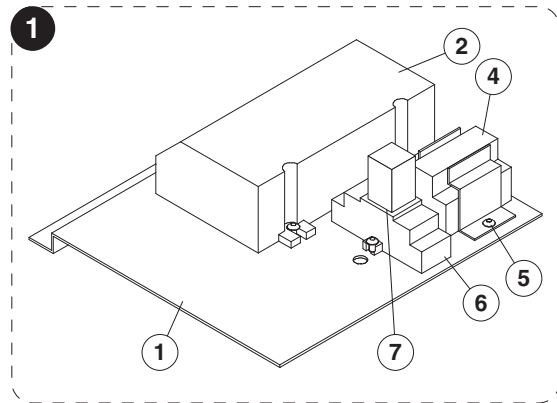

# STOP ARMS

<p><b>KE602239:</b> For units built prior to - August 2006.</p>	<p><b>KE602239-1:</b> For units built from - August 2006 to July 2011.</p>	<p><b>KE602239-3:</b> For units built from - July 2011 to October 2013.</p>	<p><b>KE602239-4:</b> For units built after - October 2013.</p>
---	--	---	---

# FLUE DIVERTER ASSEMBLY

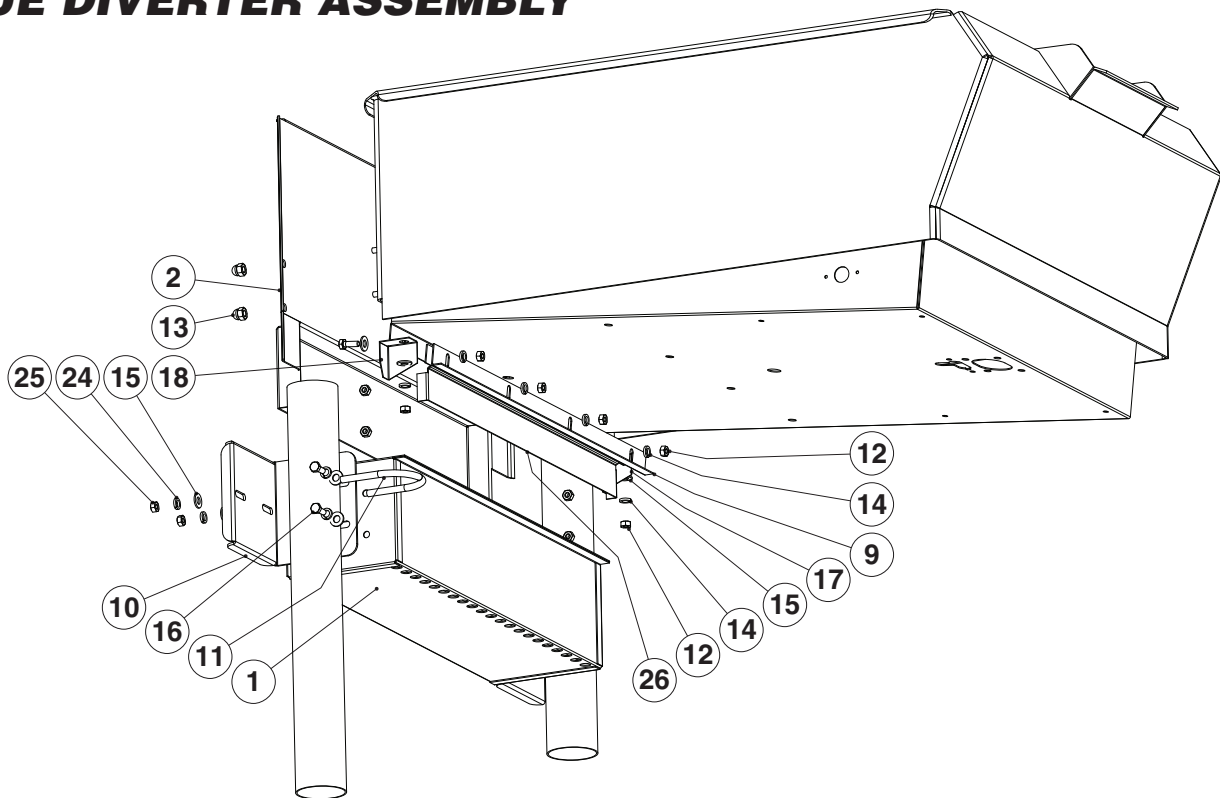

ITEM NO.	PART NO.	DESCRIPTION	QTY
1.	KE002440-1	CHANNEL WLD'T ASS'Y; 30	.1
	KE002440-2	CHANNEL WLD'T ASS'Y; 40	.1
2.	KE602434-1	FLUE FRONT; 30	.1
	KE602434-2	FLUE FRONT; 40	.1
9.	KE602438-1	ANGLE; 30	.1
	KE602438-1	ANGLE; 30	.1
10.	KE602444	BRACKET; FRAME CLAMP	.2
11.	FA95092-3	U; 3" FRAME CLAMP	.2
12.	FA21008	HEX NUT; S.S.; 1/4-20	.6/8
13.	FA21501-2	HEX HEAD DOMED NUT; S.S.; 1/4-20	.4
14.	FA31029	SPRING LOCK WASHER; 1/4 I.D.	10/12
15.	FA30505-1	FLAT WASHER; S.S.; 1/4 I.D.	14/16
16.	FA11258	HEX HEAD SCREW; S.S.; 1/4-20 X3/4	8/10
17.	KE602373-1	FILLER PIECE; R.H.	.1
18.	KE602373-2	FILLER PIECE; L.H.	.1
19.	SK2330100	SILICONE (NOT SHOWN)	.1
22.	SK2472405	GASKET, PAN TO FLUE (NOT SHOWN); 30	.1
	SK2472406	GASKET, PAN TO FLUE (NOT SHOWN); 40	.1
23.	KE602382	INSULATION (NOT SHOWN)	.1
24.	FA31030	SPRING LOCK WASHER, 5/16" I.D.	.4
25.	FA21024	HEX NUT, S.S. 5/16"-18	.4
26.	KE602568-1	FLUE BACK; 30	.1
	KE602568-2	FLUE BACK; 40	.1
27.	KE802607	INSTALLATION INSTRUCTIONS FOR SERVICE (NOT SHOWN)	.1

Every new piece of Welbilt Foodservice equipment comes with KitchenCare® and you choose the level of service that meets your operational needs from one restaurant to multiple locations

**StarCare** – Warranty & lifetime service, certified OEM parts, global parts inventory, performance audited

**ExtraCare** — CareCode, 24/7 Support, online/mobile product information

**LifeCare** – Install & equipment orientation, planned maintenance, KitchenConnect™, MenuConnect®

**Talk with KitchenCare®** • 1-844-724-CARE • [www.mtwkitchencare.com](http://www.mtwkitchencare.com)



To learn how Welbilt Foodservice and its leading brands can equip you, visit our global web site at [www.welbilt.com](http://www.welbilt.com), then discover the regional or local resources available to you.