



# Owner's Manual

## MODEL CMA-180UC-3

### INSTALLATION & OPERATION

Rev 1.00C 10-01-25



COMMERCIAL WAREWASHING  
EQUIPMENT  
NSF/ANSI 3  
<S445466>



**CMA DISHMACHINES**

17707 VALLEY VIEW AVE

CERRITOS, CALIFORNIA 90703

**800-854-6417**

FAX 714-895-2141

[www.cmadishmachines.com](http://www.cmadishmachines.com)

# Specifications

<b>CMA-180UC-3</b>	<b>METRIC EQUIVALENT</b>	
<b>WATER CONSUMPTION</b>		
PER RACK	.68 GAL.	(2.57 L)
PER HOUR	19.0 GAL.	(72.1 L)
<b>OPERATING CYCLE</b>		
WASH TIME-SEC	99	99
RINSE TIME-SEC	11	11
DWELL TIME-SEC	10	10
TOTAL CYCLE	2 MIN.	2 MIN.
<b>OPERATING CAPACITY</b>		
RACKS PER HOUR	28	28
WASH TANK CAPACITY	2.5 GAL.	(9.46 L)
PUMP CAPACITY	38 GPM	(144 LPM)
<b>WATER REQUIREMENTS</b>		
REQUIRED MINIMUM TEMP.	120°F	(49°C)
RECOMMENDED TEMP. *	140°F	(60°C)
WATER INLET	½"	1.27cm
DRAIN CONNECTION	1"	2.54cm
RINSE PRESSURE SET	20 PSI±5 PSI	1.41 kg/cm <sup>2</sup>
<b>CYCLE TEMPERATURES</b>		
WASH	160°F Minimum	(70°C)
RINSE	180°F -195°F	(82°C/90°C)
<b>FRAME DIMENSIONS</b>		
DEPTH	25"	(63.5 cm)
WIDTH	24"	(60.96 cm)
HEIGHT	33 ¼"	(84.45 cm)
MAX CLEARANCE FOR DISHES	14.5"	(36.8 cm)
<b>ELECTRICAL RATING</b>		
	<b>208 VOLTS</b> 1 PH—60 Hz	<b>240 VOLTS</b> 1 PH—60 Hz
	30 AMPS	32 AMPS
BOOSTER HEATER	5.3 kW	6.5 kW
WASH TANK HEATER	2.2 kW	2.9 kW
WASH PUMP MOTOR	3/4 HP	3/4 HP
THIS SYSTEM REQUIRES TWO POWER WIRES, NO NEUTRAL NEEDED. AN ADDITIONAL THIRD WIRE MUST BE PROVIDED FOR MACHINE GROUND. GFCI BREAKER IF REQUIRED.		
<b>SHIPPING WEIGHT</b>	234#	(106 kg)

\* For faster heat recovery.

\*\* Plus 7 seconds load time.

# Specifications

---

**Note:** The required flowing water pressure to the dishwasher is 15-65 PSIG. If pressures higher than 65 PSIG are present, a pressure regulating valve must be installed in the water line to the dishwasher (by others). If flowing pressure is lower than 15 psi, improper machine operation may result.

## **CMA-180UC-3 Operational Cycle**

The CMA-180UC-3 Operational Cycle has a total cycle time of 2 minutes (120 seconds). The steps listed below detail the individual functions that are executed during each Operational Cycle.

1. With the machine powered up toggling the START switch begins a cycle.
  - a) Toggling the START switch energizes both the Cam Timer motor and the Instant Start Relay. The Instant Start Relay latches ON the power to the Cam Timer motor so that the START switch can be released a moment after it has been toggled without the Cam Timer motor losing power.
  - b) After about 1.5 seconds the Cam Timer's first cam—the Cam Timer Motor Cam—latches ON the power to the Cam Timer motor and drops out the Instant Start Relay. The Cam Timer motor continues to run for a total of 2 minutes, at which time it switches OFF—resetting the Cam Timer—and waits for the next START command.
2. The Cam Timer's third cam controls the Wash Pump. The Wash Pump comes ON about 3 seconds into the Operational Cycle and continues to run for 94 seconds. This 94-second period is the Wash Cycle.
3. About 3 seconds after the Wash Cycle has completed the Cam Timer's second cam, which controls the Rinse Cycle, turns ON—energizing the Water Solenoid—and stays ON for 16 seconds. This 11-second period is the Rinse Cycle.
4. When the cam timer assembly approaches the final rinse portion of the cycle, the “Safe-T-Temp” fifth micro switch will pause cam timer assembly if the booster heater has not reached 180 degrees. Machine will remain in wash cycle mode until 180-degree rinse temperature is reached, and at this time the cam timer will advance automatically into the rinse cycle and dispense 180 degrees rinse water over the dishes.
5. The 4th cam controls the drain. The drain comes on before the Rinse Cycle ends and stays on until the proper water level is reached.
6. Cam switches 6 and 7 control the detergent and rinse pumps respectively. They turn ON at the beginning of the wash and rinse cycle respectively and run for a few seconds to provide sufficient detergent and rinse aid. These cams can be adjusted as necessary for proper chemical dosage. See section 4.1.1 Cam Adjustment

**Note:** Use only commercial-grade high temperature detergents and rinse additives recommended by your chemical professional. Do not use detergents and rinse additives formulated for residential dishwashers.

## CMA-180UC-3 Installation Guidelines

Improper installation of this product may void the warranty on this machine. Please follow these guidelines for recommended installation and to ensure the warranty of this model is authorized by CMA Dishmachines.

### Dishmachine Installation Requirements

1. Machine **must** be level. Adjust leveling feet to accommodate uneven floor surfaces.
2. Stand pipe drain height should not exceed maximum height of 22". Installation with air gap is recommended.
3. Approximately 4-feet of  $\frac{3}{4}$ " flexible conduit with power leads (L-1, L-2 and Ground) extending out of the conduit are provided for easily connecting the power at installation. CMA recommends a minimum 40-amp dedicated circuit, you should consult your local building code requirements for proper breaker size.

## Introduction to CMA-180UC-3

The CMA-180UC-3 is a hot water sanitizing, single rack, under-counter dishmachine. It is a standalone machine featuring a self-contained booster heater. The only external connections necessary are power supply, water supply and drainpipe. The machine uses re-circulated wash water and fresh water final-rinse.

Operation of the CMA-180UC-3 is extremely user friendly. To initially fill the machine each day, push the Power switch to the "ON" position. The machine will automatically fill to the correct level.

The wash tank heater will maintain the wash water temperature at 160°F minimum. The booster heater will produce a minimum of 180°F final rinse water each cycle.

The supply water to the CMA-180UC-3 must be a minimum of 120°F at 24 PSI (Pounds per Square Inch) with a 6 GPM (Gallons per Minute) flow rate and 60 GPH (Gallons per Hour) recovery rate. The pipe supplying the water must be ½" minimum. The plumbing connection is located at the back of the machine.

This manual is structured to provide a complete reference guide to the CMA-180UC-3. It is presented in a manner that all users will be able to comprehend and use as an effective tool in supporting the operation and maintenance of the dishmachine. The first section explains how the machine is packaged and what to look for when receiving the machine.

After unpacking the machine, this manual explains how to install and set up the machine for use. Requirements are given for plumbing, wiring, and space considerations. *These attributes of the machine are always taken into consideration by our well-trained sales representatives prior to the order being placed.* In the manual, guidance is also given for installation to ensure that the machine will be able to run at optimum conditions. The Operation Section of the manual may be used for instruction and procedures when required. We make this portion of the manual easy to understand so that all levels of operators may be able to read and comprehend the operation of the machine. The function of the machine itself is mostly automatic and takes little training to put into full operation. The Operation Section also includes diagnostic considerations for the machine should problems occur.

### DISCLAIMERS

CMA expressly disclaims any and all warranties, express or implied, relating to the installation of any and all CMA equipment that is installed by chemical dealers, contracted servicers or third party servicers to CMA equipment. If the installation instructions are not followed exactly (to the letter), or, if any person or company conducting the installation of the CMA equipment, revise the installation procedures or alter the instructions in any manner, the CMA warranty becomes void. If, due to the improper installation of CMA equipment, this equipment ceases to operate properly or affects other parts of the CMA dishwashing equipment, in that the other parts become defective, the CMA warranty becomes void. CMA will not be liable or responsible or warrant CMA equipment, due to improper installation of any CMA model dishwasher.

CMA does **NOT** endorse "Tankless On-Demand" water heaters for use on CMA Dishmachine products. On most applications, the volume of hot water required for commercial dishmachines exceeds the capacity of these types of heating sources. You will find that most, if not all, commercial dishmachines have been programmed with auto-filling features that require quick filling, with a designated limited time.

CMA **DOES** endorse, and highly recommends, the standard "tank" style water heaters, sized properly to handle each particular facility with their water heating requirements. A "tank" style water heater stores and supplies a large capacity of preheated water before providing hot water to the dishmachine. To meet required health codes, there must be a reliable and consistent flow of adequate hot water supplied to the dishmachine. If the facilities' "tank" style water heater is marginal in size, CMA recommends installing a proper size Hatco Booster Heater, a CMA's E-Temp 40 or 70-degree-rise Booster Heater (that can be installed on CMA Conveyors), or a CMA Temp-Sure Booster Heater (for door and undercounter dishmachines). All are designed to adequately achieve results.

Warning: cancer and reproductive harm – [www.P65Warnings.ca.gov](http://www.P65Warnings.ca.gov)

## Receiving and Installation

The dishwasher is shipped from the factory in a corrugated box on a wooden pallet. The installation guidelines give a systematic procedure for setting up the machine.

Start by removing the packaging material. Unwrap the machine and check for the following component parts:

The Wash Tank Scrap Screen is shipped inside the wash cavity of the machine. This screen must be in place during operation. It has been designed to perform two basic functions:

1. Strain water that is circulating through the spray arms and pump assembly.
2. A basket to catch broken glass, or heavy solids that may plug the impeller.

Set the machine in place, and level from side-to-side and front-to-back to prevent door leaks.

Steam generated from normal operation may escape from door. Wood, laminates, veneers, etc. are unsuitable materials for use in areas exposed to dishwasher steam and detergents. Stainless steel or other moisture-resistant shields are recommended for surfaces adjacent to sides and tops of under counter dishwashers.

### Electrical<sup>1</sup>

Prior to installation make sure the electrical supply is compatible with the specifications on the machines data plate.

Single-phase 208/240 volt, 60 Hz dedicated circuit should be used to supply electrical energy to the CMA-180UC-3 dishwasher (see specification sheet page 2). This system requires two power wires. An additional third wire must be provided for ground. Approximately 4-feet of ¾" flexible conduit with power leads (L-1, L-2 and Ground) extending out of the conduit are provided for easily connecting the power at installation. The power connection must be located such that there is sufficient length of the flexible conduit remaining to permit the machine to be moved for cleaning.

**WARNING:** Electrical and grounding connections must comply with the applicable portions of the National Electrical Code and/or other local electrical codes.

**Note:** For supply connections, use copper wire only rated at 90 degree C minimum.

**Advisory:** CMA Dishmachines does NOT endorse GFCI outlets. CMA does endorse hard wiring this machine (UL921 standard requirement) to a dedicated, properly sized GFCI breaker.

### Plumbing<sup>2</sup>

**Notice to Plumber:** The plumber connecting this machine is responsible for making certain that the water lines are THOROUGHLY FLUSHED OUT BEFORE connecting to the dishwasher.

The machine is equipped with a ½" NPT connection located at the lower left-hand corner (facing the back) of the machine. A 140°F water line should be plumbed to this point (see specification sheet page 2). The water line used must be of sufficient length and flexibility to permit the machine to be moved for cleaning.

The supply water to the CMA-180UC-3 must be a minimum of 120°F at 24 PSI (Pounds per Square Inch) with a 6 GPM (Gallons per Minute) flow rate and 60 GPH (Gallons per Hour) recovery rate. The pipe supplying the water must be ½" minimum. The plumbing connection is located at the back of the machine. (See specification sheet on page 2).

**Note:** high iron levels in the water supply can cause staining and may require an iron filter. High chlorine levels in the water supply can cause pitting and may require a chloride removal system. If an inspection of the dishwasher or booster heater reveals lime buildup after the equipment has been in service, water treatment is recommended. If water softener is already in place, ensure there is a sufficient level of salt.

<sup>1,2</sup>All electrical and plumbing connections must be made by a qualified person who will comply with all available Federal, State, and Local Health, Electrical, Plumbing and Safety codes

# Getting Started

---

**Warning:** If water pressure exceeds 50 PSI, pressure reducing valve (PRV) is recommended. The CMA-180UC-3 is manufactured with a pumped drain. The drain pump can not be removed.

**Caution:** CMA recommends utilizing a water softening system to maintain water hardness measurements of 3.5 gpg (grains per gallon) or less. This will assure maximum results and optimum operation of the dishmachine.

## Detergent And Rinse Chemical Dispenser

The built-in chemical dispenser assembly has easy access for chemical settings on the cam timer.

**Note:** Use only commercial-grade detergents and rinse aids recommended by your chemical professional. Do not use detergents and rinse aids formulated for residential dishwashers.

## Safe-T-Temp Feature

The CMA “Safe-T-Temp” feature assures the final rinse cycle is always at a consistent minimum of 180 degrees.

**How it works:** the “Safe-T-Temp” function operates off the 5<sup>th</sup> cam (labeled “Safe-T-Temp”) on the timer assembly. When the cam timer assembly completes the wash cycle, and approaches the final rinse portion of the cycle, the “Safe-T-Temp” micro switch will drop into the cam slot and pause cam timer assembly if the booster heater has not reached 180 degrees. Machine will remain in wash cycle mode until 180 degree rinse temperature is met, and at this time the cam timer will advance automatically into the rinse cycle and dispense 180 degrees rinse water over the dishes.

---

<sup>1</sup> All electrical and plumbing connections must be made by a qualified person who will comply with all available Federal, State, and Local Health, Electrical, Plumbing and Safety codes

## Installers Checklist

- Dishmachine checked for concealed damage
- Hot water supply is 120° F (60 C) — minimum
- Incoming water supply line is ½" — minimum
- Incoming water supply is 6 GPM minimum at 24 PSI
- Supply circuit breaker for machine is properly sized (40 amp)
- Service voltage and phase type are correct to machine data plate
- Drain hose is installed with air gap (discharge 1" above drain)
- Dishmachine is properly grounded
- Dishmachine is properly leveled
- Machine circuit breaker is labeled "DISHWASHER"
- Machine has been "hard-wired" with correctly sized wire

## ***Initial Setup***

### **Rinse and Wash Temperatures<sup>3</sup>**

1. Turn the Power switch to the "ON" position.
2. After the machine has warmed up for 10-15 minutes, note the wash temperature. The wash temperature must be 160°F minimum. The rinse temperature must be 180°F minimum<sup>3</sup>.
3. The wash tank digital thermostat has been factory set to 160°F, no adjustment should be necessary. If necessary adjust the wash tank thermostat up using the ^ button. If necessary, adjust the booster temperatures by removing the lower front panel and turning the booster heater thermostat adjustments clockwise to increase, counterclockwise to decrease.

### **Post Instructions**

1. Install wall chart and instruct machine operator on proper cleaning and operation of the CMA-180UC-3.

## ***Startup Procedures***

1. Open the door of the machine and check that the scrap screen is in place, and that the spray arms and end plugs are secure.
2. Close the door of the machine and press the Power switch to the "ON" position.
3. The machine will automatically fill to the correct level. The fill timer in the upper control drawer may be adjusted as needed.
4. Allow the machine 10-15 minutes to heat up, 160°F on the "WASH" temperature display before continuing.
5. Press the rocker switch marked "START" – the machine will automatically begin its cycle.
6. Check machine's operating temperatures — Adjust thermostats if necessary.
7. At the end of the meal period, drain the machine by pressing and holding the rocker switch marked "DRAIN" till empty. Clean the wash tank screen and scrap tray screen. Remove and clean the spray arms. (See wall chart instructions).
8. To prime chemical dispensers press and hold down the prime switch until product is discharging into machine.
9. Drain machine and power machine off at end of day.

---

<sup>3</sup> Rinse cycle temperature must be observed during a rinse cycle while the machine is in operation.

## Trouble Shooting guide

MODEL: CMA 180UC -3HIGH TEMP UNDER COUNTER

TECHNICAL ISSUE	CAUSE	SOLUTION
Door leaks	Machine not level	Adjust machine legs to level
	Machine is leaning forward	Adjust machine legs to level
	Wash arm end cap missing	Replace end cap, P/N 00308.20
	Door gasket	Replace gasket, P/N 14506.60
Thermometer failure	Loose wire at display, board or transformer	Secure connectors
	Faulty temperature sensing wire	Correct, replace, P/N 03202.66
	Faulty temperature sensing unit	Replace unit, P/N 03203.01
	Faulty transformer	Replace transformer, P/N 03202.55
Rinse water temperature low /high	Scaled heating element	Clean scale from heater
	Booster heater's thermostat not properly set	Adjust thermostat
	Incoming water temperature to booster heater below 140 F	Adjust external water heater in the facility
Pump motor not running	Loose lead connections	Check and crimp connectors
	Faulty # 3 micro switch	Replace micro switch, P/N 00411.00
	Faulty contactor	Replace contactor, P/N 00404.81
	Faulty wash pump motor	Replace wash pump motor, P/N 00201.67
Pump motor runs continuously	Faulty # 3 micro switch	Replace micro switch, P/N 00411.00
	Faulty contactor	Replace contactor, P/N00404.81
	Water regulator not adjusted properly	Adjust regulator to 15-25 PSI
Low water pressure at the final rinse	Clogged final rinse spray jets	Clean jets
	Missing final rinse spray end cap	Replace end cap, P/N 00308.17
	Low incoming water pressure from facility	Increase pressure to 15-25 psi
	Faulty water solenoid diaphragm	Clean or replace diaphragm, P/N 00706.00
Machine overflows over night	Low wash or rinse water temp.	Check temperature settings
	Wash arm bearing or jets	Clean bearing and arm jets
	Rinse arm bearing or jets	Clean bearing and arm jets
Wash tank will not drain.	Drain switch not working	Replace drain switch
	Drain pump not operating	Check power to drain pump
	Drain pump faulty	Replace Drain pump

## Trouble Shooting guide

PROBLEM	LIKELY CAUSE	SOLUTION
Machine inoperative	Power off at circuit breaker	Reset circuit breaker
	Defective power switch	Replace power switch P/N: <a href="#">00421.83</a>
Motor inoperative	Door is open	Close door
	Control panel is pulled out	Secure control panel
	Defective reed switch	Replace reed switch P/N: <a href="#">00558.11</a>
	Defective timer assembly	Replace timer assembly* P/N: <a href="#">14408.89</a>
	Defective pump motor contactor	Replace contactor P/N: <a href="#">00404.81</a>
	Defective motor	Replace motor P/N: <a href="#">00201.67</a>
Motor runs with door open	Defective reed switch	Replace reed switch P/N: <a href="#">00558.11</a>
	Defective pump motor contactor	Replace contactor P/N: <a href="#">00404.81</a>
Heaters (no heat)	High limit switch opened or defective	Reset or replace switch P/N: <a href="#">17523.51</a>
	Defective thermostat	Replace thermostat <a href="#">13417.92</a> Booster & <a href="#">13440.00</a> Wash
	Defective heater contactor	Replace heater contactor <a href="#">15504.55</a> Booster & <a href="#">13012.26</a> Wash
	Defective element	Replace element <a href="#">15518.00</a> Booster & <a href="#">13415.48</a> Wash
Heaters (never turns off)	Defective thermostat	Replace thermostat <a href="#">13417.92</a> Booster & <a href="#">13440.00</a> Wash
	Defective heater contactor	Replace heater contactor <a href="#">15504.55</a> Booster & <a href="#">13012.26</a> Wash

\*The timer assembly motor (P/N: [00501.10](#)) or micro switches (P/N: [00411.00](#)) can be replaced independently if that's the only component that's failed.

# Operation

PROBLEM	LIKELY CAUSE	SOLUTION
Low heat during operation	Low incoming water temperature (below 140° F)	Turn up supply water heater Insulate supply water pipe
	Thermostat out of adjustment	Adjust thermostat
	Cold water mixing with supply	Isolate hot water from cold water
	Defective element	Replace heater <a href="#">15518.00</a> Booster & <a href="#">13415.48</a> Wash
Low rinse water pressure	Pressure regulator out of adjustment	Adjust pressure regulator
	Defective pressure gauge (actual pressure is okay)	Replace pressure gauge P/N: <a href="#">13605.45</a>
Regulator at maximum but rinse pressure still low	Insufficient water supply flow	Supply larger supply line
	Defective water solenoid valve	Replace water solenoid valve P/N: <a href="#">00705.05</a>
Low rinse water flow	Low rinse water pressure	See “Low rinse water pressure” in <b>PROBLEM</b> column
	Limed up rinse arm spray nozzles	De-lime rinse arm nozzles
No rinse water flow	Defective water solenoid valve	Replace water solenoid valve P/N: <a href="#">00705.05</a>
	Defective (Rinse Relay) ice cube relay	Replace ice cube relay P/N: <a href="#">00631.05</a>
Rinse water runs with door open	Defective reed switch	Replace reed switch P/N: <a href="#">00558.11</a>
With power on, activating start switch does not begin cycle	Defective start switch (cycle light will not light either)	Replace start switch P/N: <a href="#">00421.35</a>
	Defective timer assembly	Replace timer assembly* P/N: <a href="#">14408.89</a>

\*The timer assembly motor (P/N: [00501.10](#)) or micro switches (P/N: [00411.00](#)) can be replaced independently if that's the only component that's failed.

# Operation

PROBLEM	LIKELY CAUSE	SOLUTION
Start switch requires > 3 second activation to run cycle	Defective (Instant Start) ice cube relay	Replace ice cube relay P/N: <a href="#">00631.05</a>
Fill (rinse water) won't shut off	Defective water solenoid valve	Replace water solenoid valve P/N: <a href="#">00705.05</a>
	Defective air pressure switch	Replace air pressure switch P/N: <a href="#">02100.41</a>
	Defective timer assembly	Replace timer assembly* P/N: <a href="#">14408.89</a>
	Defective (Rinse Relay) ice cube relay	Replace ice cube relay P/N: <a href="#">00631.05</a>
Pressing and holding drain switch does not drain machine	Drain hose is kinked	Un-kink drain hose
	Defective drain switch	Replace drain switch P/N: <a href="#">00421.89</a>
	Defective drain pump	Replace drain pump P/N: <a href="#">02100.17</a>
Wash tank or final rinse temperature does not display	Defective digital thermometer	Replace digital thermometer P/N: <a href="#">03203.01</a>
Both the wash tank temperature and the final rinse temperature do not display	Defective thermometer transformer	Replace thermometer transformer P/N: <a href="#">03202.55</a>
Wash tank or final rinse displays wrong temperature	Defective digital thermometer	Replace digital thermometer P/N: <a href="#">03203.01</a>
	Defective thermister	Replace thermister P/N: <a href="#">03202.66</a>



# OPERATING AND CLEANING INSTRUCTIONS FOR MODEL CMA-180UC-3 INSTRUCCIONES DE LIMPIEZA Y OPERACION DE MODELO CMA-180UC-3

**1** Turn on power and machine will fill automatically to correct level.  
*Prenda la maquina y automaticamente va a llenar al nivel correcto.*

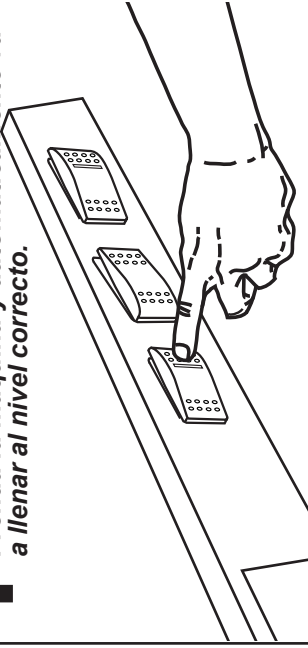

**2** Start machine by pushing start button.  
*Para empezar la maquina, cierre la puerta y oprima el boton de encendido.*

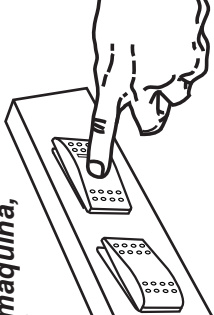

**160°** °F  
WASH TEMP 160°

**CAUTION: DO NOT START until wash temperature reads 160°.**  
*No empiece el ciclo hasta que la temperatura sea 160°.*

**3** Drain machine by pressing drain button.  
*Para vaciar la maquina: Oprima el boton de drenaje.*

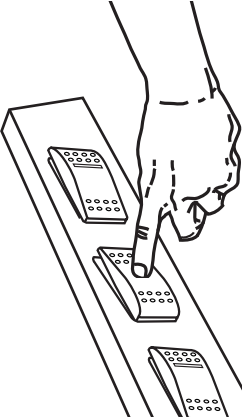

**4** Turn off power.  
*Apague La Maquina*

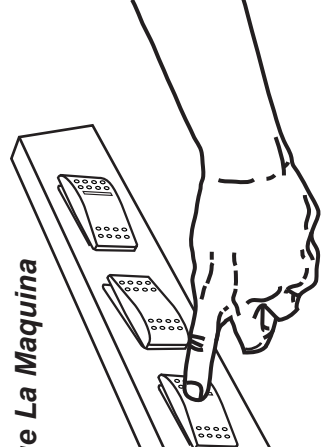

**5** If spray arms are clogged remove by turning bearings counter clockwise.  
*Si los brazos de rociado se tapan, sera necesario sacarlos desenroscandolos para el lado izquierdo.*

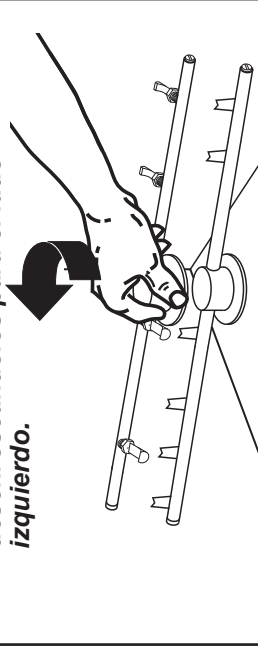

**6** Inspect top and bottom spray arm jets daily. Use toothpick and push trash into spray arm. Remove end plugs and flush with water.  
*Use un palillo para abrir los orificios. Destapar por las puntas, removiendo el tapon y enjuagelos con agua.*

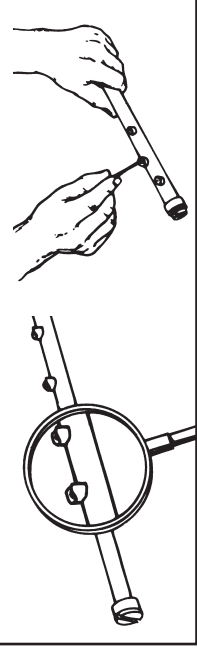

**7** Hand remove and thoroughly clean scrap screen under faucet or Pre-Rinse Hose every shift.  
*Remueva el filtro de el interior de el tanque de desperdicios. Lave el filtro con el rociador de agua cada turno.*

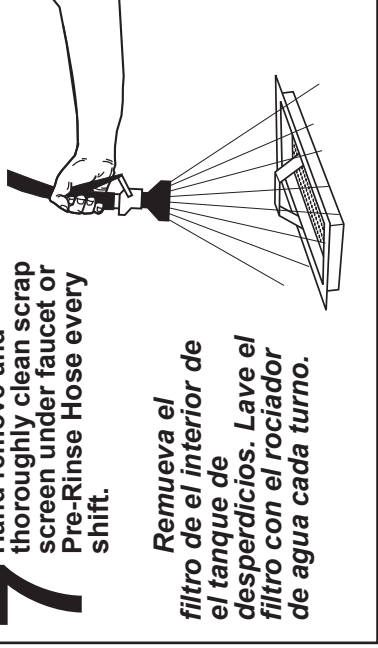

**8** Replace all scrap screen back into position.  
*Regrese el filtro a su lugar.*

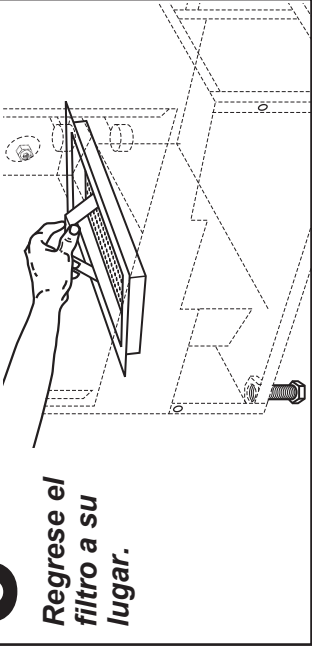

# CMA 180UC-3 ELECTRICAL DIAGRAM POWER BOX

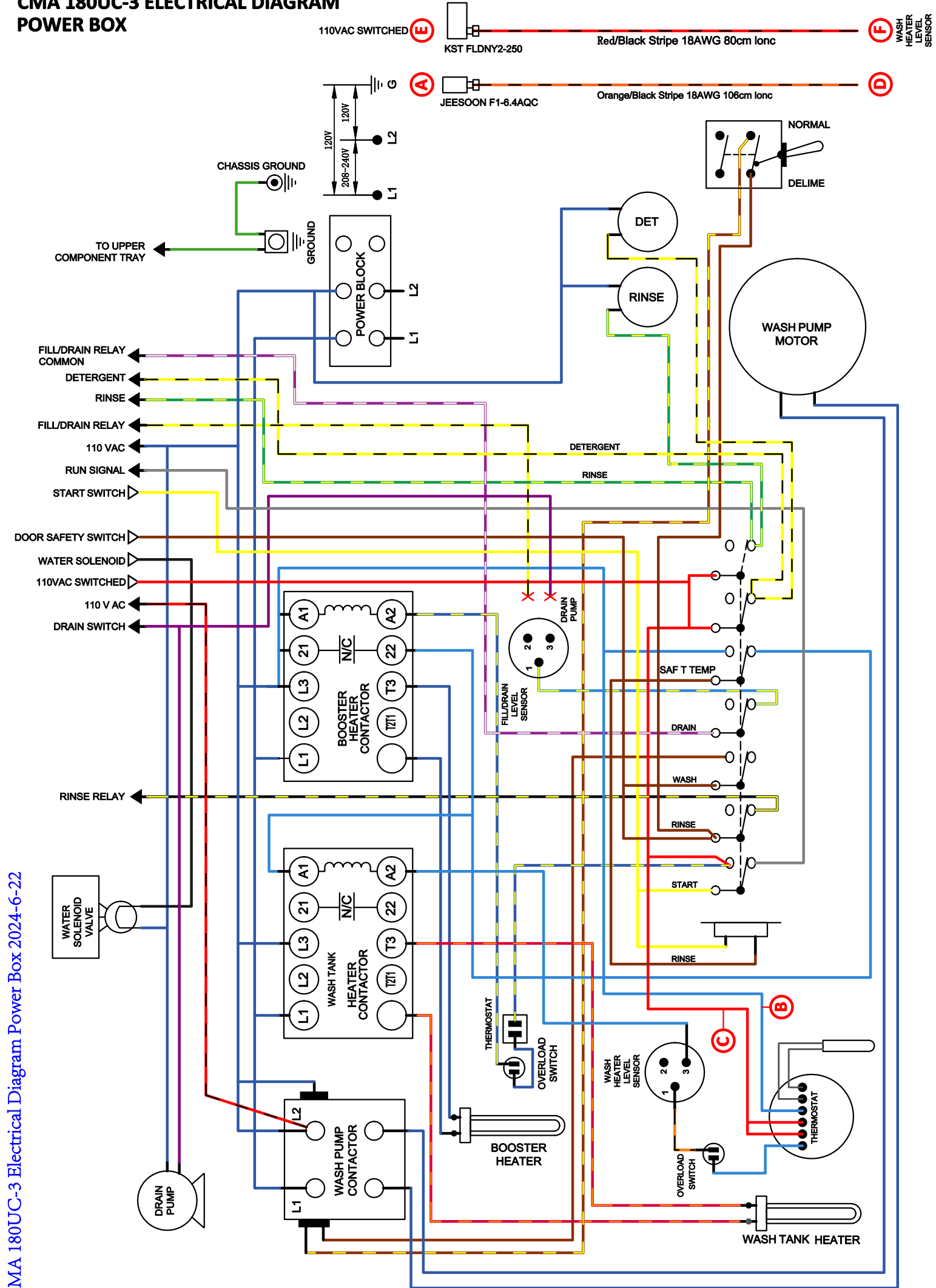

# 180UC-3 CONTROL DRAWER

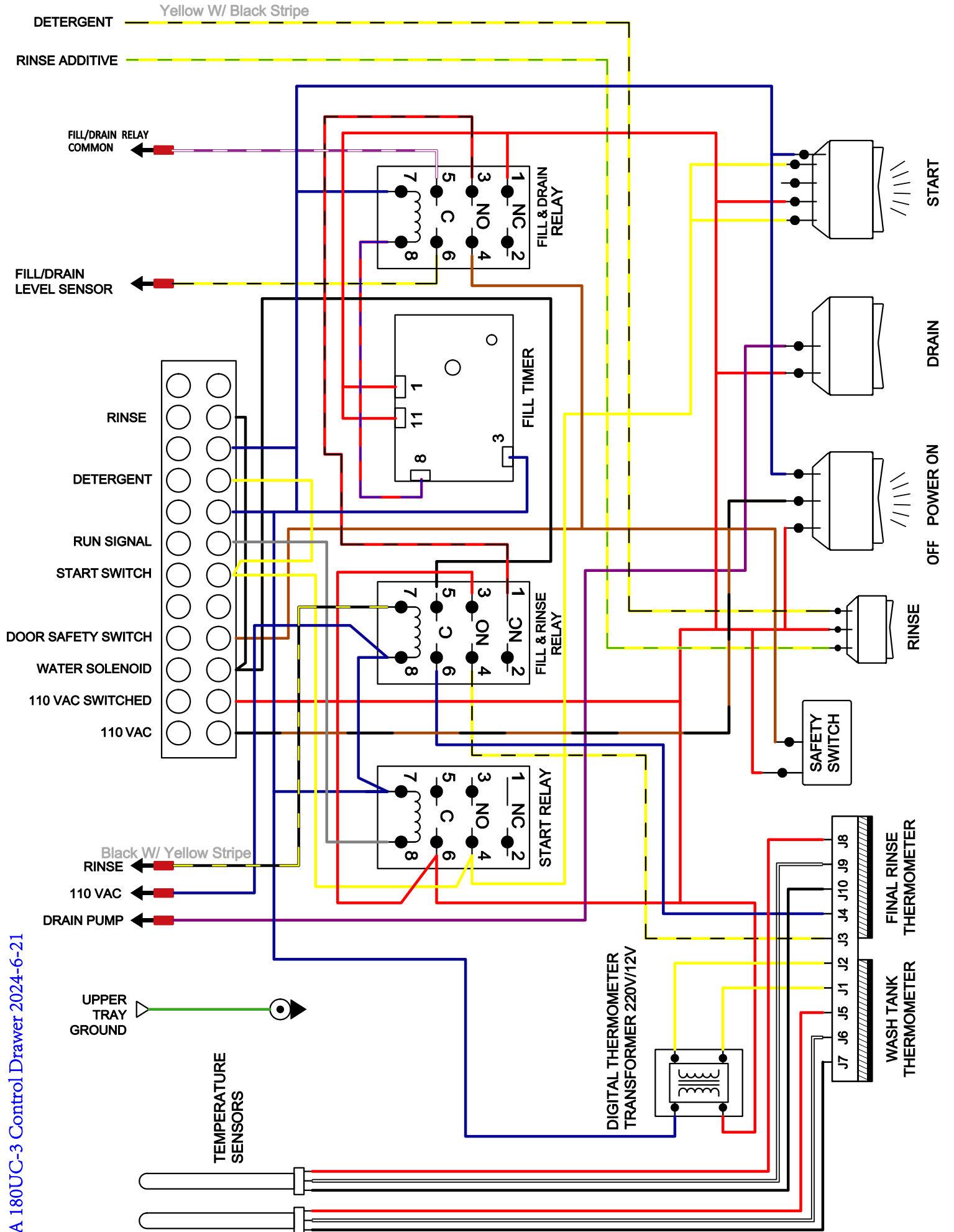

# CMA 180UC-3 ELECTRICAL DIAGRAM POWER BOX

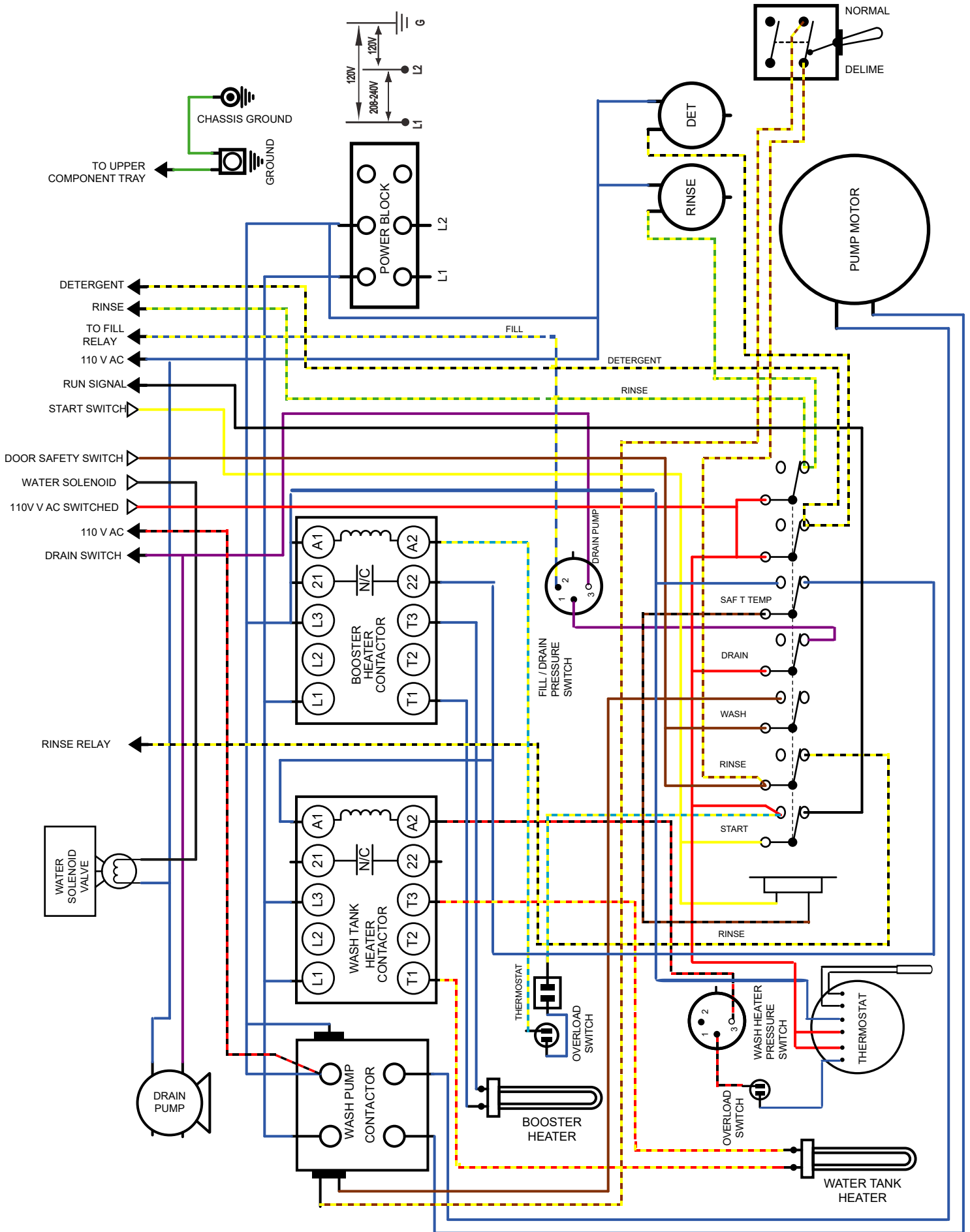

# 180UC-3 CONTROL DRAWER

