



Owner's Manual

MODEL CMA-180UC

INSTALLATION & OPERATION

Rev 1.20 03-01-2022



CMA DISHMACHINES
12700 KNOTT STREET
GARDEN GROVE, CALIFORNIA 92841

800-854-6417

FAX 714-895-2141

www.cmadishmachines.com

TABLE OF CONTENTS

MODEL CMA-180UC

1. SPECIFICATIONS	2
1.1. CMA-180UC	2
1.2. CMA-180UC OPERATIONAL CYCLE.....	3
2. GETTING STARTED.....	5
2.1. INTRODUCTION TO CMA-180UC	5
2.2. RECEIVING AND INSTALLATION.....	6
2.2.1. Electrical	6
2.2.2. Plumbing.....	6
2.2.3. Detergent And Rinse Chemical Dispenser (Optional).....	7
2.2.4. External Detergent and Rinse Dispenser (Optional).....	8
2.2.5. Safe-T-Temp Feature	10
2.2.6. Drain Water Tempering Kit	11
2.2.7. Booster Heater Setup.....	12
2.2.8. Installers Checklist	12
3. OPERATION	13
3.1. INITIAL SETUP	13
3.1.1. Rinse Pressure Regulator (Models manufactured prior to January 2008 and starting April 2018).....	13
3.1.2. Flow Disc (Models manufactured between January 2008 and April 2018).....	13
3.1.3. Rinse and Wash Temperatures	13
3.1.4. Post Instructions	13
3.2. STARTUP PROCEDURES.....	13
3.3. OPERATING AND CLEANING INSTRUCTIONS	15 & 16
3.4. PREVENTIVE MAINTENANCE CHART	17
3.5. QUICK SERVICE GUIDE.....	18
3.6. TROUBLESHOOTING.....	19
4. PARTS KIT	22
4.1. INITIAL PARTS KIT (P/N 1100.66).....	22
4.2. DRAIN PUMP	23
4.3. DRAIN PUMP REMOVAL INSTRUCTIONS	24
5. CUSTOMER NOTICE	25
6. ELECTRICAL DIAGRAMS	26

Specifications

1. Specifications

1.1. CMA-180UC	METRIC EQUIVALENT	
WATER CONSUMPTION		
PER RACK	.75 GAL.	(2.83 L)
PER HOUR	17.9 GAL.	(67.6 L)
OPERATING CYCLE		
WASH TIME-SEC	94	94
RINSE TIME-SEC	16	16
DWELL TIME-SEC	10	10
TOTAL CYCLE	2 MIN.	2 MIN.
OPERATING CAPACITY		
RACKS PER HOUR	30	30
WASH TANK CAPACITY	2.5 GAL.	(9.46 L)
PUMP CAPACITY	38 GPM	(144 LPM)
WATER REQUIREMENTS		
REQUIRED MINIMUM TEMP.	120°F	(49°C)
RECOMMENDED TEMP.	140°F	(60°C)
WATER INLET	½"	1.27cm
DRAIN CONNECTION	1"	2.54cm
RINSE PRESSURE SET	20 PSI±5 PSI	1.41 kg/cm ²
CYCLE TEMPERATURES		
WASH-°F	150°F -160°F	(65.5°C/71°C)
RINSE-°F	180°F -195°F	(82°C/90°C)
FRAME DIMENSIONS		
DEPTH	25"	(63.5 cm)
WIDTH	24"	(60.96 cm)
HEIGHT	33 ¼"	(84.45 cm)
MAX CLEARANCE FOR DISHES	14.5"	(36.8 cm)
ELECTRICAL RATING*	208 VOLTS 1 PH—60 Hz	230 VOLTS 1 PH—60 Hz
	33 AMPS	35 AMPS
BOOSTER HEATER	5.3 kW	6.5 kW
WASH PUMP MOTOR	1 HP	1 HP
THIS SYSTEM REQUIRES THREE POWER WIRES, WHICH INCLUDES A CURRENT CARRYING NEUTRAL. AN ADDITIONAL FOURTH WIRE MUST BE PROVIDED FOR MACHINE GROUND. GFCI BREAKER IF REQUIRED IS OK. HARDWIRE ONLY, NO OUTLET.		
SHIPPING WEIGHT	234#	(106 kg)

Note: The required water pressure to the dishwasher is 15-65 PSI. If pressure is lower than 15 psi, improper machine operation may result.

Specifications

1.2. CMA-180UC Operational Cycle

The CMA-180UC Operational Cycle has a total cycle time of 2 minutes (120 seconds). The Timing Diagram and the steps listed below detail the individual functions that are executed during each Operational Cycle.

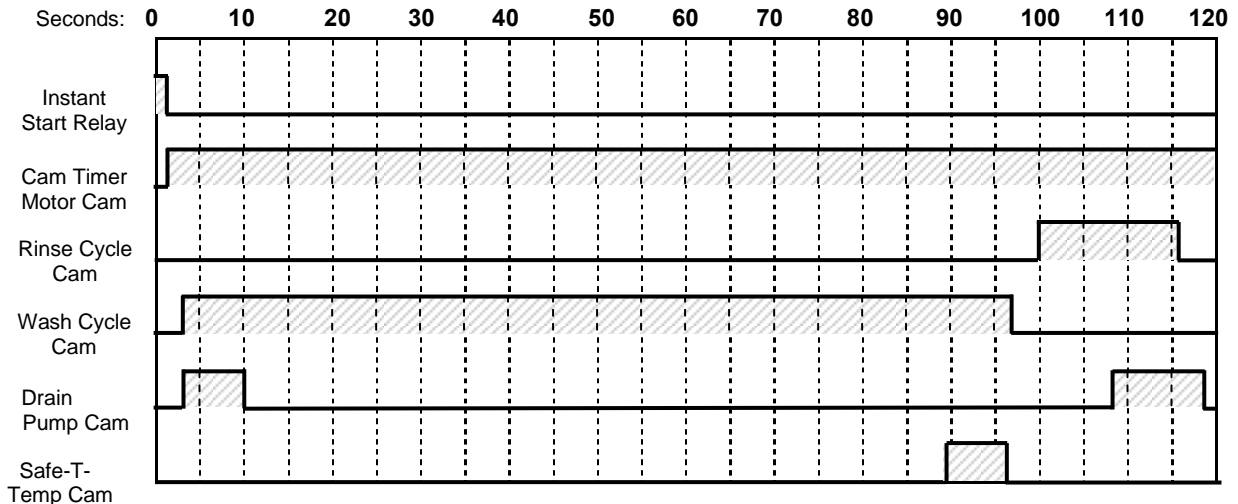

1. With the machine powered up toggling the START switch begins a cycle.
 - a) Toggling the START switch energizes both the Cam Timer motor and the Instant Start Relay. The Instant Start Relay latches ON the power to the Cam Timer motor so that the START switch can be released a moment after it has been toggled without the Cam Timer motor losing power.
 - b) After about 1.5 seconds the Cam Timer's first cam—the Cam Timer Motor Cam—latches ON the power to the Cam Timer motor and drops out the Instant Start Relay. The Cam Timer motor continues to run for a total of 2 minutes, at which time it switches OFF—resetting the Cam Timer—and waits for the next START command.
2. The Cam Timer's third cam controls the Wash Pump. The Wash Pump comes ON about 3 seconds into the Operational Cycle and continues to run for 94 seconds. This 94-second period is the Wash Cycle.
3. At the same time that the Wash Pump comes ON the Cam Timer's fourth cam powers ON the Drain Pump—if one is present—and keeps it running for about 7 seconds before powering OFF. This cam turns ON again midway through the Rinse Cycle and stays ON for 10 seconds, turning OFF 2 seconds after the Rinse Cycle has completed.

Specifications

4. About 3 seconds after the Wash Cycle has completed the Cam Timer's second cam, which controls the Rinse Cycle, turns ON—energizing the Water Solenoid—and stays ON for 16 seconds. This 16-second period is the Rinse Cycle.
5. When the cam timer assembly approaches the final rinse portion of the cycle, the “Safe-T-Temp” fifth micro switch will pause cam timer assembly if the booster heater has not reached 180 degrees. Machine will remain in wash cycle mode until 180-degree rinse temperature is reached, and at this time the cam timer will advance automatically into the rinse cycle and dispense 180 degrees rinse water over the dishes.
6. Cam switches 6 and 7 (not shown) found on machines built after January 2020 control the detergent and rinse pumps respectively. They turn ON at the beginning of the wash and rinse cycle respectively and run for a few seconds to provide sufficient detergent and rinse additive. These cams can be adjusted as necessary for proper chemical dosage. See section 4.1.1 Cam Adjustment

Note: Use only commercial-grade detergents and rinse additives recommended by your chemical professional. Do not use detergents and rinse additives formulated for residential dishwashers.

2. Getting Started

2.1. Introduction to CMA-180UC

This manual is structured to provide a complete reference guide to the CMA-180UC. It covers every version produced so some items may not be applicable to your 180UC.

The CMA-180UC is a hot water sanitizing, single rack, under-counter dishmachine. It is a standalone machine featuring a self-contained booster heater. The only external connections necessary are power supply, water supply, drainpipe, and optional chemical dispensers for machines made before 2019. The machine uses re-circulated wash water and fresh water final-rinse.

Operation of the CMA-180UC is extremely user friendly. To initially fill the machine each day, push the Power switch to the "ON" position. Press and hold the "Fill" button for 25 seconds. Machines built prior to January 2020 will automatically fill to the correct level when powered "ON".

The 180UC has one heater located in the booster tank that heats the wash tank too. It will maintain the wash water temperature at 155°F. The booster heater will produce a minimum of 180°F final rinse water each cycle.

The supply water to the CMA-180UC must be a minimum of 120°F with a 4 GPM (Gallons per Minute) flow rate. The supply line must be ½" minimum. The plumbing connection is located at the back of the machine.

The machine retains the features of the standard CMA-180 Series in that it has a scrap tray and the manner in which the tank is filled ensures that the dishes are always rinsed with fresh water instead of re-circulated water. The CMA-180UC is the first under-counter dishmachine of its kind to discharge soil from the wash tank into a scrap tray outside of the wash chamber. This feature keeps the wash water much cleaner over long periods of time. The scrap tray may be emptied on a periodic basis without interruption of the flow of work, thereby providing a much cleaner environment for the wash and rinse cycle.

The first section explains how the machine is packaged and what to look for when receiving the machine. After unpacking the machine, this manual explains how to install and set up the machine for use. Requirements are given for plumbing, wiring, and space considerations. *These attributes of the machine are always taken into consideration by our well-trained sales representatives prior to the order being placed.* In the manual, guidance is also given for installation to ensure that the machine will be able to run at optimum conditions. The Operation Section of the manual may be used for instruction and procedures when required. We make this portion of the manual easy to understand so that all levels of operators may be able to read and comprehend the operation of the machine. The function of the machine itself is mostly automatic and takes little training to put into full operation. The Operation Section also includes diagnostic considerations for the machine when problems occur.

DISCLAIMERS

CMA expressly disclaims any and all warranties, express or implied, relating to the installation of any and all CMA equipment that is installed by chemical dealers, contracted servicers or third party servicers to CMA equipment. If the installation instructions are not followed exactly (to the letter), or, if any person or company conducting the installation of the CMA equipment, revise the installation procedures or alter the instructions in any manner, the CMA warranty becomes void. If, due to the improper installation of CMA equipment, this equipment ceases to operate properly or affects other parts of the CMA dishwashing equipment, in that the other parts become defective, the CMA warranty becomes void. CMA will not be liable or responsible or warrant CMA equipment, due to improper installation of any CMA model dishwasher.

CMA does NOT endorse "Tankless On-Demand" water heaters for use on CMA Dishmachine products. On most applications, the volume of hot water required for commercial dishmachines exceeds the capacity of these types of heaters. CMA DOES endorse, and highly recommends, the standard "tank" style water heaters, sized properly to handle each particular facility with their water heating requirements. A "tank" style water heater stores and supplies a large capacity of preheated water before providing hot water to the dishmachine. To meet required health codes, there must be a reliable and consistent flow of adequate hot water supplied to the dishmachine.

Warning: cancer and reproductive harm – www.P65Warnings.ca.gov

2.2. Receiving and Installation

The dishwasher is shipped from the factory in a corrugated box on a wooden pallet. The installation guidelines give a systematic procedure for setting up the machine.

Start by removing the packaging material. Unwrap the machine and check for the following component parts:

The Wash Tank Scrap Screen is shipped inside the wash cavity of the machine. This screen must be in place during operation. It has been designed to perform two basic functions:

1. Strain water that is circulating through the spray arms and pump assembly.
2. A basket to catch broken glass, or heavy solids that may plug the impeller.

Set the machine in place, and level from side-to-side and front-to-back to prevent door leaks.

Steam generated from normal operation may escape from door. Wood, laminates, veneers, etc. are unsuitable materials for use in areas exposed to dishwasher steam and detergents. Stainless steel or other moisture-resistant shields are recommended for surfaces adjacent to sides and tops of under counter dishwashers.

2.2.1. Electrical¹

Prior to installation make sure the electrical supply is compatible with the specifications on the machines data plate.

Single-phase 230 volt, 60 Hz hard-wired dedicated circuit should be used to supply electrical energy to the CMA-180UC dishwasher (see specification sheet page 2). This system requires three power wires, which include a current carrying neutral. An additional fourth wire must be provided for ground. Approximately 4-feet of ¾" flexible conduit with power leads (L-1, L-2, Neutral and Ground) extending out of the conduit are provided for easily connecting the power at installation. The power connection must be located such that there is sufficient length of the flexible conduit remaining to permit the machine to be moved for cleaning.

WARNING: Electrical and grounding connections must comply with the applicable portions of the National Electrical Code and/or other local electrical codes.

Note: For supply connections, use copper wire only rated at 90 degree C minimum.

2.2.2. Plumbing²

Notice to Plumber: The plumber connecting this machine is responsible for making certain that the water lines are THOROUGHLY FLUSHED OUT BEFORE connecting to the dishwasher.

The supply water to the CMA-180UC must be a minimum of 120°F with a 4 GPM (Gallons per Minute) flow rate. The pipe supplying the water must be ½" minimum. The plumbing connection is located at the back of the machine. The machine is equipped with a connection located at the lower left-hand corner (facing the back) of the machine. A 120°F minimum water line should be plumbed to this point (see specification sheet page 2). The water line used must be of sufficient length and flexibility to permit the machine to be moved for cleaning.

Note: high iron levels in the water supply can cause staining and may require an iron filter. High chlorine levels in the water supply can cause pitting and may require a chloride removal system. If an inspection of the dishwasher or booster heater reveals lime buildup after the equipment has been in service, water treatment is recommended. If water softener is already in place, ensure there is a sufficient level of salt.

^{1,2}All electrical and plumbing connections must be made by a qualified person who will comply with all available Federal, State, and Local Health, Electrical, Plumbing and Safety codes

Getting Started

Warning: If water pressure exceeds 50 PSI, pressure reducing valve (PRV) is recommended.

The CMA-180UC is supplied with a drain pump for elevated drains. For floor gravity drain applications the drain pump should not be used and a good commercial grade hose needs to be connected to the discharge side of the diverter valve (drain valve) and run to the floor drain. If removing a drain pump, safe-end (insulate electrically) the white and purple wires and secure them out of the way. If a drain pump is used with a floor drain, the drain hose must rise 12 to 16" before dropping to the floor drain (to reduce any chance of the pump cavitations).

Caution: CMA recommends utilizing a water softening system to maintain water hardness measurements of 3.5 gpg (grains per gallon) or less. This will assure maximum results and optimum operation of the dishmachine.

2.2.3. Detergent And Rinse Chemical Dispenser (Prior to January 2020)

Optional built-in chemical dispenser Assembly (CMA P/N 14585.00) has easy access for chemical settings behind the front kick panel. Both initial charge and recharge is factory pre-set. Basic settings for both detergent and rinse speed are 50%. Operating fine-adjustment screws on the dispenser can control the amount of chemicals drawn into chemical lines.

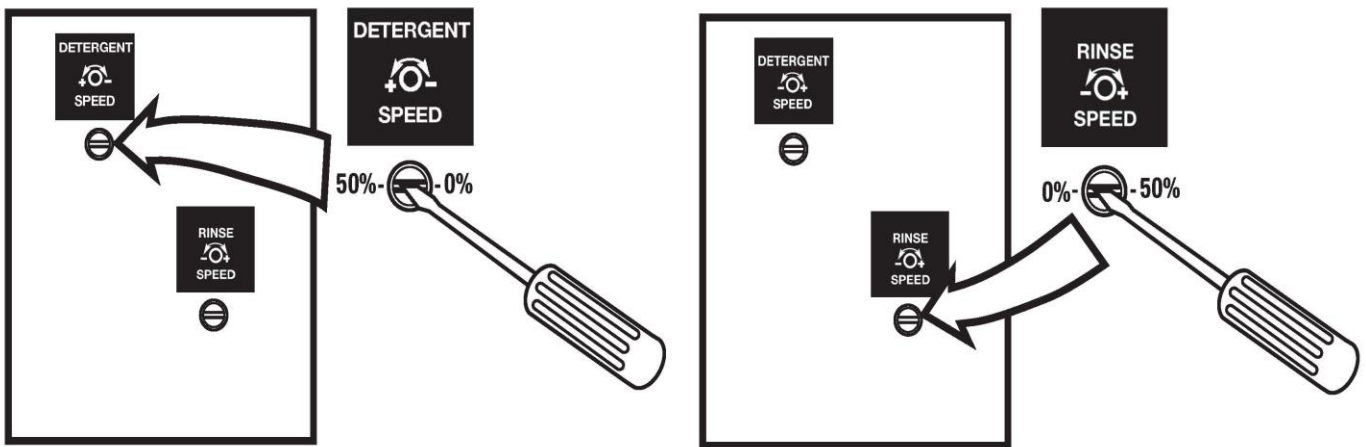

Undercounter machine with the optional dispenser must be ordered separately, as option at time of order. Optional dispenser has to be pre-wired prior to shipment (see electrical diagram for wiring options). CMA Dishmachines chemical dispenser for detergent and rinse additive has been added to all 180UC's built after January 2020.

Note: Use only commercial-grade detergents and rinse aids recommended by your chemical professional. Do not use detergents and rinse aids formulated for residential dishwashers.

¹ All electrical and plumbing connections must be made by a qualified person who will comply with all available Federal, State, and Local Health, Electrical, Plumbing and Safety codes

2.2.4. External Detergent and Rinse Dispenser (Optional)¹.

The NOVA Detergent and Rinse Dispenser has its own reference manual. Familiarize yourself with the dispenser's reference manual before proceeding with installation.

1. The NOVA dispenser is pre-wired with a multi-conductor electrical cable that is to be run through a conduit to the power block inside the control panel drawer. Use a ½" watertight conduit meeting all local and national codes. A conduit fitting is present on the bottom of the dispenser where the power cable exits. A mounting plate to receive the ½" conduit is provided on the top right-hand corner (facing the back) of the machine.
 - i. Run an appropriate length of ½" conduit from your dispenser to the mounting plate where it will be secured. The conduit needs to be of sufficient length and flexibility to permit the machine to be moved for cleaning without having to disconnect any wiring.
 - ii. Run your dispenser wires through the conduit and through the enclosed area across the top of the machine and then feed them through the access hole provided in the back of the control panel drawer.
 - iii. With the machine's power "OFF", connect your detergent and rinse dispenser wires to the power block supplied and labeled ("DISPENSER 110V - 3 AMPS MAX") inside the control panel drawer. The table that follows lists the function of each conductor of the multi-conductor electrical cable.

Wire Colors	Circuit Voltage	Function
Gray/Violet	90 VAC-130 VAC 50/60 Hz	Main AC Power
Black	90 VAC-130 VAC 50/60 Hz	Main AC Power
Brown	No Connection. Insulate this wire!	This wire is LIVE!
Yellow	90 VAC-130 VAC 50/60 Hz	Detergent Signal
White/Yellow	90 VAC-130 VAC 50/60 Hz	Detergent Signal
Violet	90 VAC -130 VAC 50/60 Hz	Rinse Signal
White/Violet	90 VAC -130 VAC 50/60 Hz	Rinse Signal

The individual conductors need to be connected as shown in Figure 2.2.4 and as described on next page.

¹ All electrical and plumbing connections must be made by a qualified person who will comply with all available Federal, State, and Local Health, Electrical, Plumbing and Safety codes

Getting Started

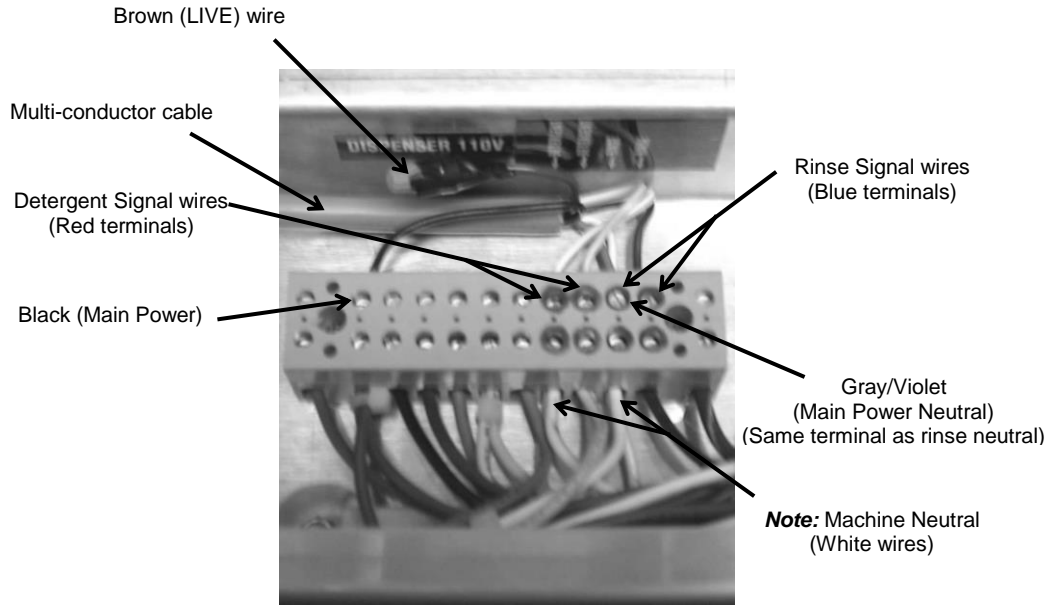

Figure 2.2.4

Note: In Figure 2.2.4 the machine's wire harness was left out of the back of the power block to more clearly show the dispenser wires.

2. Remove the plug from the mixing chamber located by the vacuum breaker on the back of machine; and install the rinse injection fitting (supplied with your dispenser). See Figure 2.2.4.

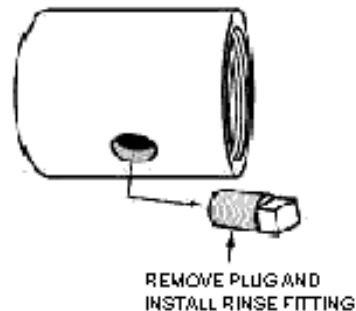

Figure 2.2.4.

3. A 7/8" detergent injection hole is provided in the back of the wash tank. Remove the S.S. plug and install the detergent fitting (supplied with your dispenser).
4. The final step of installing the CMA supplied Detergent and Rinse Dispenser is programming it to your specific application. The reference manual supplied with the dispenser shows you how to program it.
 - Keep in mind while reading the reference manual that the CMA-180UC operates in "probe-less" mode. (This mode is selected by setting a value of "2" in screen 21).
 - Screen 22 must be set to "1" (Door).

2.2.5. Safe-T-Temp Feature

The CMA “Safe-T-Temp” feature assures the final rinse cycle is always at a consistent minimum of 180 degrees.

How it works: the “Safe-T-Temp” function operates off the 5th cam (labeled “Safe-T-Temp”) on the timer assembly. When the cam timer assembly completes the wash cycle, and approaches the final rinse portion of the cycle, the “Safe-T-Temp” micro switch will drop into the cam slot and pause cam timer assembly if the booster heater is still heating. Machine will remain in wash cycle mode until the rinse temperature is met, and at this time the cam timer will advance automatically into the rinse cycle and dispense fresh water final rinse water over the wares.

Note: if Safe-T-temp cam is not to be used, it becomes a spare cam.

CMA -180UC “Safe-T-Temp” Installation Instructions:

- 1) Remove the 4cam timer assembly (note wire colors and wire placement for all 4cam timer micro switches) and install 5cam timer in its place.
- 2) Place all wires removed from 4cam timer assembly in exact position on 5cam timer assembly.
- 3) The cam timer motor receives (1) yellow wire and (1) white wire (re-connect the yellow wire only from dishmachine harness to the motor).
- 4) The “SafeTemp” 5 cam timer assembly kit includes a two white harness – connect white wire with female bullet connector to the timer motor, stripped end to #22/NC on contactor, and spade end to center terminal 5th micro switch.
- 5) Connect white wire with male bullet connector from the kit to the white wire with female bullet connector coming from dishmachine harness, stripped end to #21/NC on contactor, and spade end to top terminal on 5th micro switch.

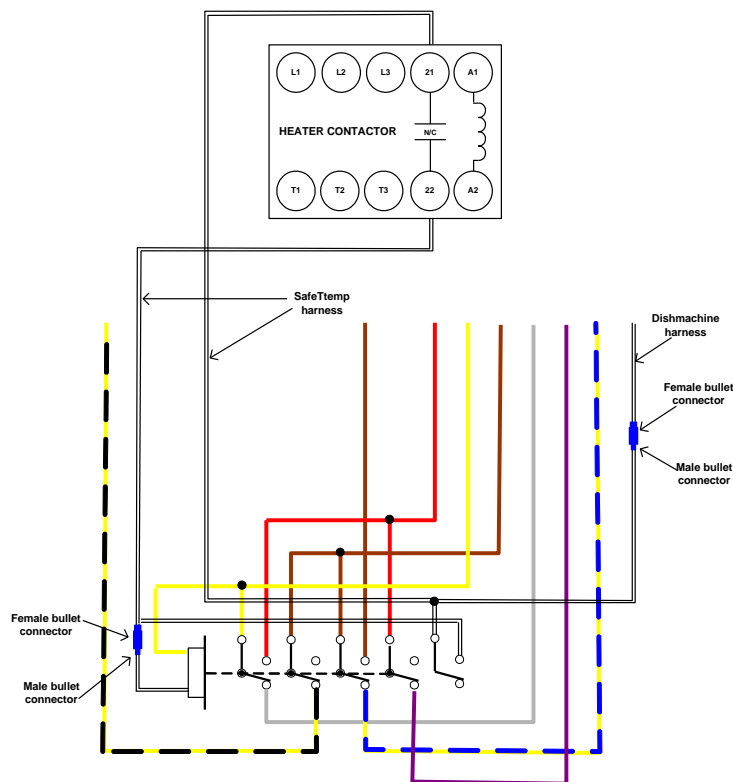

2.2.6. Drain Water Tempering Kit

180UC Water Tempering Valve Kit

P/N 13470.50

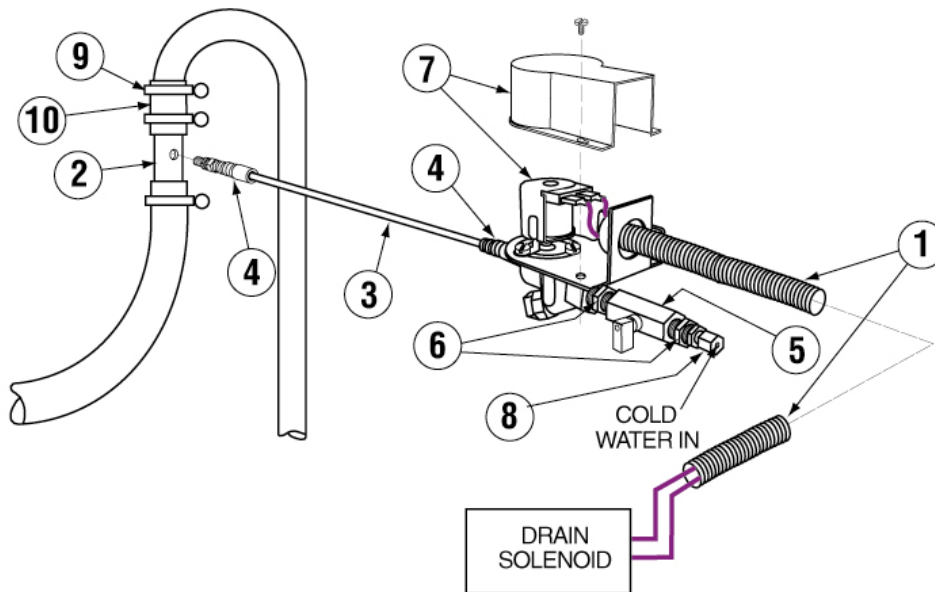

INSTALLATION INSTRUCTIONS TO DRAIN TEMPERING KIT

NOTE: Turn the dishwasher's wall breaker to "OFF" position before this installation.

1. Undo the drain hose clamp connecting the drain line gooseneck to drain hose leading to floor drain.
2. Install the water junction tee as shown on drain line gooseneck and tighten clamp.
3. Connect the drain hose to lower port of water injection tee and tighten hose clamp.
4. Insert the provided white chemical tube into compression nut of water injection tee and tighten compression nut.
5. Connect the provided cold-water solenoid's power leads to the drain solenoid.
6. Connect the water injection assembly's ball valve to a cold water supply.
7. Run the dishwasher through a few cycles and make sure the cold water is injected and check for any possible leaks.

ITEM NO.	P/N	NO REQ'D	DESCRIPTION
1.	15400.17	2.5	3/8" SLIT RIBBED TUBING
2.	15603.50	1	GOOSE NECK PIPE ADAPTER TEE
3.	00425.54	2	CHEMICAL TUBING WHITE
4.	03415.50	2	FLEX-TIGHT FITTING
5.	41014.49	1	3/8" BALL VALVE
6.	40015.00	2	3/8"X1/4" HEX BUSHING
7.	41015.00	1	SOLENOID VALVE 1/4" W/COVER 115V
8.	40116.00	1	1/4" COMP X 1/4" MIP FTG
9.	03101.00	2	HOSE CLAMP #16 1"
10.	03108.60	.25	TRANSFER HOSE 1" REINFORCED

2.2.7. Booster Heater Setup (After Jan 2020)

Activating/Adjusting the Booster Heater

1. Booster heater **must** be filled with water prior to connecting the blue wire from high limit switch. The high limit switch can be found by removing the front panel and locating the red button on the front of the heater tank.
2. Once the booster has been connected, the thermostat should be adjusted to maintain 180°F during the final rinse cycle. The thermostat is located on the front of the booster tank and is accessible by removing the front panel on the machine.

2.2.7. Booster Heater Setup (Prior to Jan 2020)

The booster tank must be filled with water before the heating element is energized. For this reason the "High Limit Switch" has intentionally been disconnected at the factory and will require re-connection before the heating element will turn on.

Follow the procedure below to complete the initial installation:

1. Close the door on the machine.
2. Turn the Power switch to the "ON" position.
3. On initial setup push Booster Fill button to fill the booster heater.
4. Turn Power switch OFF and On.
The machine will be automatically filled to the correct level.
5. Turn the Power switch to the "OFF" position.
6. Connect blue wire with disconnect, identified by red tag, to the High Limit Switch which is located below the thermostat behind the front kick panel.

2.2.8. Installers Checklist

- Dishmachine checked for concealed damage
- Hot water supply is 120° F (49 C) — minimum
- Incoming water supply line is ½" — minimum
- Supply circuit breaker for machine is properly sized
- Service voltage and phase type are correct to machine data plate
- If drain pump is used, stand pipe drain should not exceed 22" maximum height from the floor
- Drain hose is installed with air gap (discharge 1" above drain)
- Optional detergent and rinse dispenser (if present) is properly installed
- Dishmachine is properly grounded
- Dishmachine is properly leveled
- Machine circuit breaker is labeled "DISHWASHER"
- Machine has been "hard-wired" with correctly sized wire
- Booster tank has been filled with water (before High Limit Switch is reset)
- High Limit Switch for heater has been reset (after Booster Tank has been filled)

3. Operation

3.1. *Initial Setup*

3.1.1. Rinse Pressure Regulator (Models manufactured prior to January 2008 and starting April 2018 to current).

The CMA-180UC requires a supply water input pressure of 24 PSI minimum. This pressure is then reduced by the supply water regulator. Use the following procedure to adjust the rinse pressure to 20 PSI:

1. Close the door on the machine. Turn the Power switch to the "ON" position.
2. Machines built prior to January 2020 will be automatically filled to the correct level.
3. Machines built after January 2020 press and hold the "FILL" button for 25 seconds.
4. Adjust the pressure regulator until the gauge the gauge reads 20 PSI. Regulator is located behind the front kick panel.

3.1.2. Flow Disc (Models manufactured between January 2008 and April 2018).

Flow Disc has been placed on the exit side of the water valve. The Flow Disc reduces pressure to the standard recommended 20 PSI.

3.1.3. Rinse and Wash Temperatures³

1. Turn the Power switch to the "ON" position.
2. After the machine has warmed up for 10-15 minutes, note the wash temperature. The wash temperature must be 155°F minimum. The rinse temperature must be 180°F minimum. Rinse temperature will only display during RINSE section of cycle. If necessary, adjust the temperatures by removing the front kick panel and turning the thermostat adjustment clockwise to increase, counterclockwise to decrease. This one adjustment controls both temperatures.

3.1.4. Post Instructions

1. Install wall chart and instruct machine operator on proper cleaning and operation of the CMA-180UC.

3.2. *Startup Procedures*

1. Open the door of the machine and check that the scrap screen is in place, and that the spray arms and end plugs are secure.
2. Close the door of the machine and turn the Power switch to the "ON" position. The machine will be automatically filled to the correct level for machines built prior to Jan 2020. Press and hold the "FILL" button for 25 seconds for machines built after Jan 2020.
3. Press the rocker switch marked "START" – the machine will automatically begin its cycle.
4. Check machine's operating temperatures — Adjust if necessary. See section 3.1.3 Rinse and Wash Temperatures.

Operation

5. At the end of the wash period, drain the machine by pressing and holding the rocker switch marked "DRAIN". Clean the wash tank screen and scrap tray screen. Remove and clean the spray arms. (See wall chart instructions).
6. To prime chemical dispensers press and hold down prime switch until product is discharged into dishmachine.



OPERATING AND CLEANING INSTRUCTIONS FOR MODEL CMA-180UC

OPERACION DE MODELO CMA-180UC

3.3. Operating and Cleaning Instructions

1 Turn on power, press and hold FILL button for 25 seconds
Prenda la maquina y presione el boton de llenar por 25 segundos

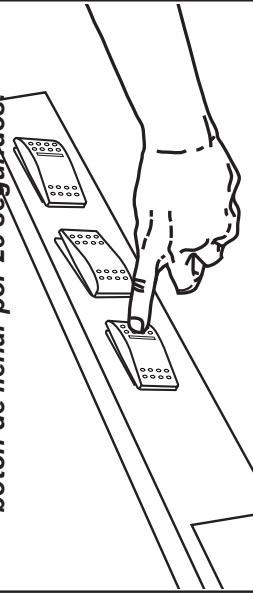

2 Start machine by pushing start button.
Para empezar la maquina, cierre la puerta y oprima el boton de encendido.

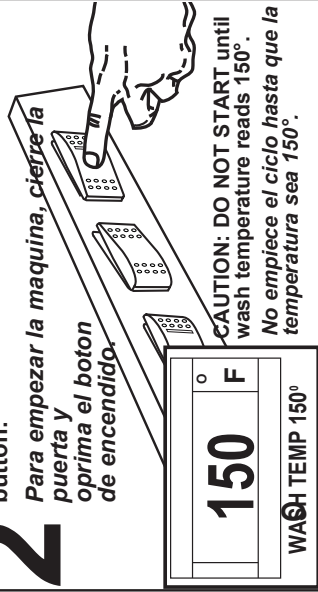

CAUTION: DO NOT START until wash temperature reads 150°.
No empiece el ciclo hasta que la temperatura sea 150°.

150 ° F
WASH TEMP 150°
-160°

3 Drain machine by pressing drain button.
Para vaciar la maquina: Oprima el boton de drenaje.

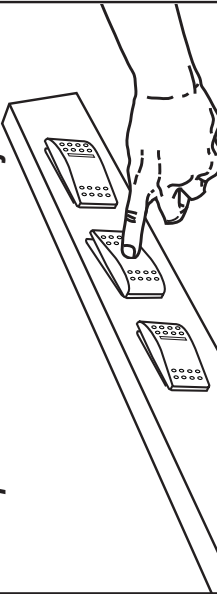

4 Turn off power.
Apague la maquina.

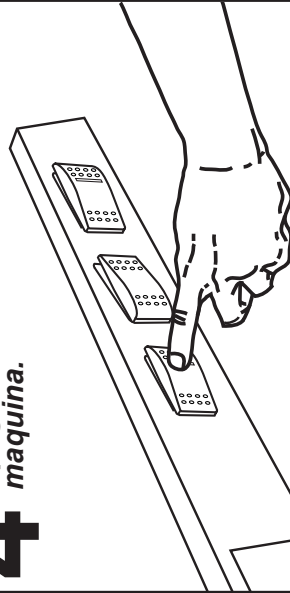

5 If spray arms are clogged remove by turning bearings counter clockwise.
Si los brazos de rociado se tapan, sera necesario sacarlos desenroscandolos para el lado izquierdo.

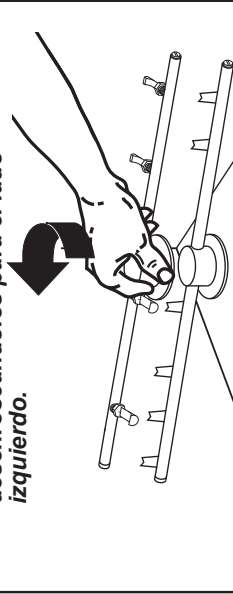

6 Inspect top and bottom spray arm jets daily. Use toothpick and push trash into spray arm. Remove end plugs and flush with water.
Use un palillo para abrir los orificios. Destapar por las puntas, removiendo el tapon y enjuagelos con agua.

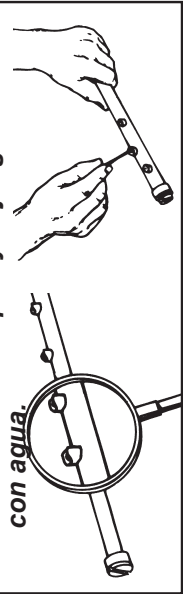

7 Hand remove and thoroughly clean filter, scrap screen and scrap basket under faucet or Pre-Rinse Hose every shift.
Remueva el filtro de el interior de el tanque de desperdicios. Lave el filtro y los dos cedazos con el rociador de agua cada turno.

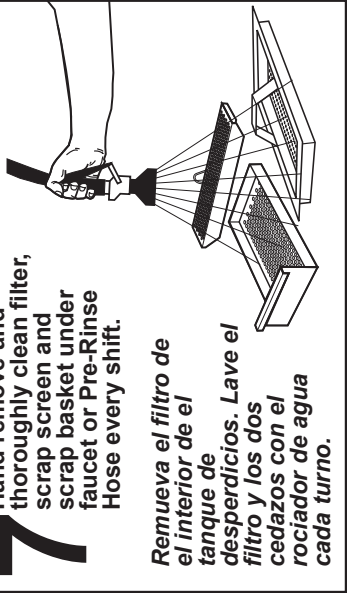

8 Replace all (3) screens back into position.
Regrese filtro y los cedazos a su lugar.

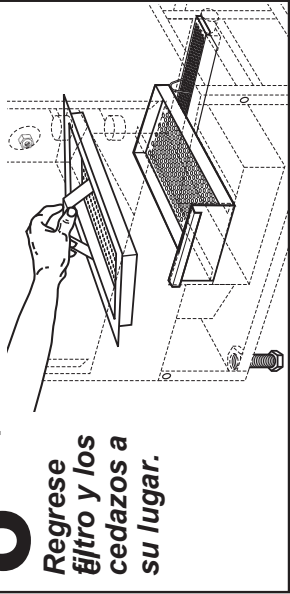

3.3. Operating and Cleaning Instructions



OPERATING AND CLEANING INSTRUCTIONS FOR MODEL CMA-180UC INSTRUCCIONES DE LIMPIEZA Y OPERACION DE MODELO CMA-180UC

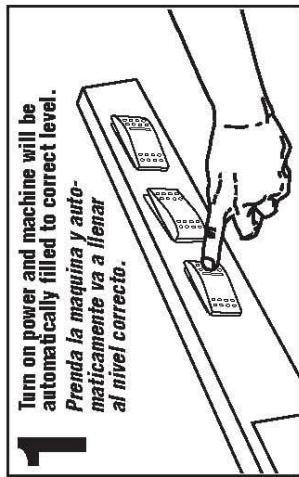

1 Turn on power and machine will be automatically filled to correct level.
Prenda la maquina y automaticamente va a llenar al nivel correcto.

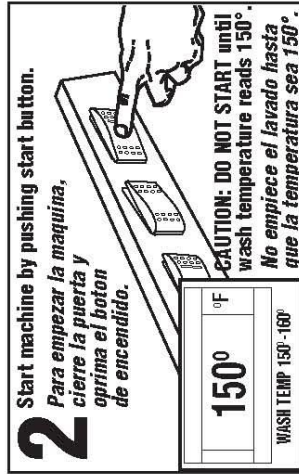

2 Start machine by pushing start button.
Para empezar la maquina, cierre la puerta y oprima el boton de encendido.

CAUTION: DO NOT START until wash temperature reads 150°.
No empiece el lavado hasta que la temperatura sea 150°.

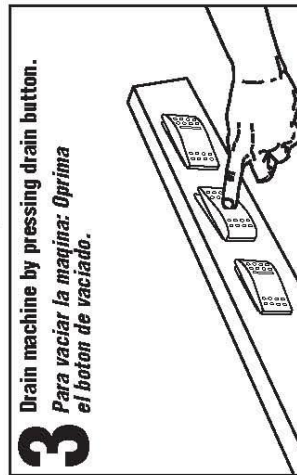

3 Drain machine by pressing drain button.
Para vaciar la maquina: Oprima el boton de vaciado.

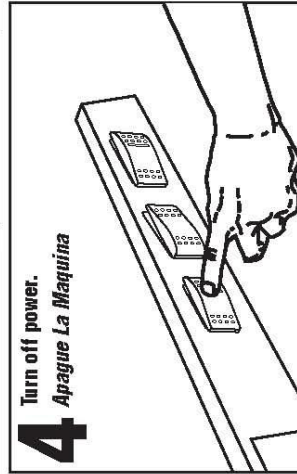

4 Turn off power.
Apague La Maquina

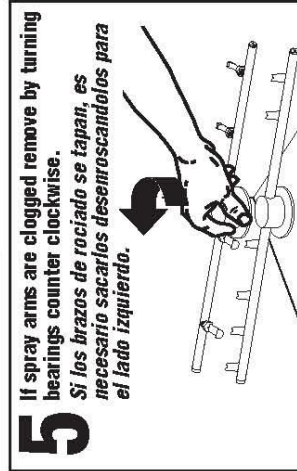

5 If spray arms are clogged remove by turning bearings counter clockwise.
Si los brazos de rociado se tapan, es necesario sacarlos desatorascandolos para el lado izquierdo.

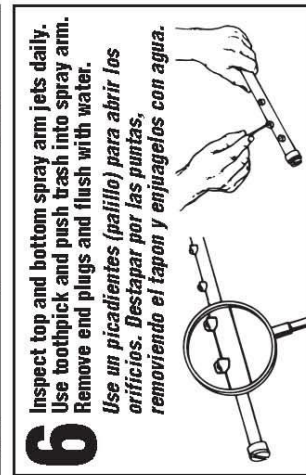

6 Inspect top and bottom spray arm jets daily. Use toothpick and push trash into spray arm. Remove end plugs and flush with water.
Use un picadientes (patillo) para abrir los orificios. Destapar por las puntas, removiendo el tapon y enjuagelos con agua.

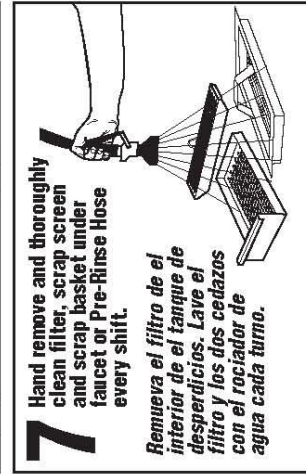

7 Hand remove and thoroughly clean filter, scrap screen and scrap basket under faucet or Pre-Rinse Hose every shift.
Remueva el filtro de el interior de el tanque de desperdicios. Lave el filtro y los dos cedazos con el rociador de agua cada turno.

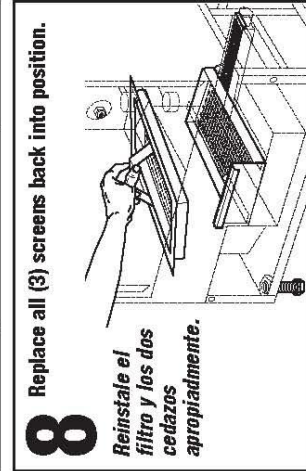

8 Replace all (3) screens back into position.
Reinstale el filtro y los dos cedazos apropiadamente.

CMA PN: 06265.10

1-2017

3.4. Preventive Maintenance Chart



PREVENTIVE MAINTENANCE FOR MODEL CMA-180UC

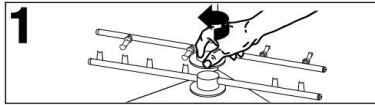

1 If rinse arm jets are clogged, remove rinse arm (by turning bearing counter clockwise) and clean out rinse jets with paper clip or small pointed object.

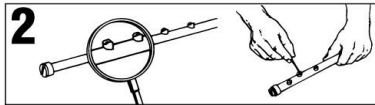

2 Inspect top and bottom spray arms daily. Use toothpick to push debris into spray arm. Remove end plugs and flush with water.

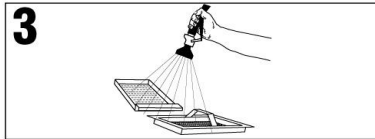

3 Remove and thoroughly clean scrap tray, and scrap drawer daily.

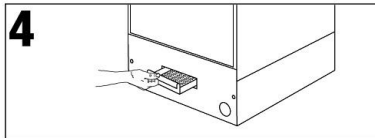

4 Replace screens after cleaning.

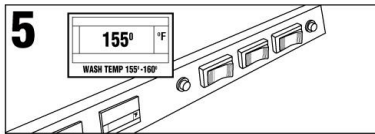

5 Confirm wash temperature is 155°F.

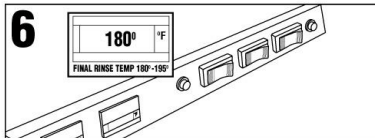

6 Check rinse temperature minimum 180°F. Notify supervisor if rinse temperature is below 180°F.

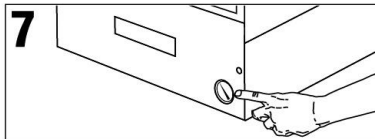

7 Check rinse pressure 15-22 psi.

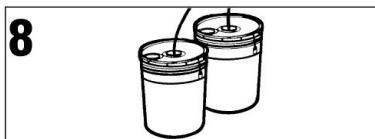

8 Check chemical containers for product. Confirm correct product line is in the bucket.
RED - Detergent
BLUE - Rinse Aid



9 Check machine for leaks.

1-28-05

3.5. Quick service guide

MODEL: CMA 180UC HIGH TEMP UNDER COUNTER

TECHNICAL ISSUE	CAUSE	SOLUTION
Scrap trap over flows	Pressure regulator is not set properly	Set regulator to 15-25 psi
	Faulty rinse micro switch	Replace micro switch, P/N 00411.00
	Drain hose elevated too high	Must be lowered to goose neck level
	Obstruction in drain hose	Check hose & clean
	Scrap exit screen	Clean exit screen
	Faulty drain pump	Replace pump, P/N 15503.00
Door leaks	Machine not level	Adjust machine legs to level
	Machine is leaning forward	Adjust machine legs to level
	Wash arm end cap missing	Replace end cap, P/N 00308.20
	Door gasket	Replace gasket, P/N 14506.60
Thermometer failure	Loose wire at display, board or transformer	Secure connectors
	Faulty temperature sensing wire	Correct, replace, P/N 03202.66
	Faulty temperature sensing unit	Replace unit, P/N 03203.00
	Faulty transformer	Replace transformer, P/N 03202.60
Rinse water temperature low /high	Scaled heating element	Clean scale from heater
	Booster heater's thermostat not properly set	Adjust thermostat
	Incoming water temperature to booster heater below 140 F	Adjust external water heater in the facility
Pump motor not running	Loose lead connections	Check and crimp connectors
	Faulty # 3 micro switch	Replace micro switch, P/N 00411.00
	Faulty contactor	Replace contactor, P/N 15504.00
	Faulty wash pump motor	Replace wash pump motor, P/N 00201.00
Pump motor runs continuously	Faulty # 3 micro switch	Replace micro switch, P/N 00411.00
	Faulty contactor	Replace contactor, P/N015504.00
Low water pressure at the final rinse	Water regulator not adjusted properly	Adjust regulator to 18-20 PSI
	Clogged final rinse spray jets	Clean jets
	Missing final rinse spray end cap	Replace end cap, P/N 00308.17
	Low incoming water pressure from facility	Increase pressure to 18-20 psi
Scrap trap overflows over night	Faulty water solenoid diaphragm	Clean or replace diaphragm, P/N 00706.00
Poor cleaning results	Low wash or rinse water temp.	Check temperature settings
	Wash arm bearing or jets	Clean bearing and arm jets
	Rinse arm bearing or jets	Clean bearing and arm jets
Wash tank will not drain.	Tank discharge screen dirty	Clean screen
	Drain valve not operating	Check power to drain valve
	Drain valve faulty	Replace Drain valve, P/N 04103.00

3.6. Troubleshooting

PROBLEM	LIKELY CAUSE	SOLUTION
Machine inoperative	Power off at circuit breaker	Reset circuit breaker
	Defective power switch	Replace power switch P/N: 15521.50
Motor inoperative	Door is open	Close door
	Control panel is pulled out	Secure control panel
	Defective reed switch	Replace reed switch P/N: 00557.55
	Defective timer assembly	Replace timer assembly* P/N: 14408.80
	Defective pump motor contactor	Replace contactor P/N: 15504.00
	Defective motor	Replace motor P/N: 00201.66
Motor runs with door open	Defective reed switch	Replace reed switch P/N: 00557.55
	Defective pump motor contactor	Replace contactor P/N: 15504.00
Heater (no heat)	High limit switch opened or defective	Reset or replace switch P/N: 17523.51
	Defective thermostat	Replace thermostat P/N: 13417.89
	Defective heater contactor	Replace heater contactor P/N: 15504.50
	Defective heater	Replace heater P/N: 15517.00
Heater (never turns off)	Defective thermostat	Replace thermostat P/N: 13417.89
	Defective heater contactor	Replace heater contactor P/N: 15504.50

*The timer assembly motor (P/N: [00501.00](#)) or micro switches (P/N: [00411.00](#)) can be replaced independently if that's the only component that's failed.

Operation

PROBLEM	LIKELY CAUSE	SOLUTION
Low heat during operation	Low incoming water temperature (below 140° F)	Turn up supply water heater Insulate supply water pipe
	Thermostat out of adjustment	Adjust thermostat
	Cold water mixing with supply	Isolate hot water from cold water
	Defective heater	Replace heater P/N: 15517.00
Low rinse water pressure	Pressure regulator out of adjustment	Adjust pressure regulator
	Defective pressure gauge (actual pressure is okay)	Replace pressure gauge P/N: 13605.45
Regulator at maximum but rinse pressure still low	Insufficient water supply flow	Supply larger supply line
	Defective water solenoid valve	Replace water solenoid valve P/N: 00705.00
Low rinse water flow	Low rinse water pressure	See “Low rinse water pressure” in PROBLEM column
	Limed up rinse arm spray nozzles	De-lime rinse arm nozzles
No rinse water flow	Defective water solenoid valve	Replace water solenoid valve P/N: 00705.00
	Defective (Rinse Relay) ice cube relay	Replace ice cube relay P/N: 00631.00
Rinse water runs with door open	Defective reed switch	Replace reed switch P/N: 00557.55
Water overflows scrap tray onto floor	Drain hose is kinked	Un-kink drain hose
	Drain hose is not properly elevated before dropping to drain (if drain pump is used)	Elevate drain hose 12 to 16” above pump before dropping to drain
	Defective timer assembly	Replace timer assembly* P/N: 14408.80
	Defective drain pump (if drain pump is used)	Replace drain pump P/N: 15503.00
With power on, activating start switch does not begin cycle	Defective start switch (cycle light will not light either)	Replace start switch P/N: 15521.00
	Defective timer assembly	Replace timer assembly* P/N: 14408.80

*The timer assembly motor (P/N: [00501.00](#)) or micro switches (P/N: [00411.00](#)) can be replaced independently if that’s the only component that’s failed.

Operation

PROBLEM	LIKELY CAUSE	SOLUTION
Start switch requires > 3 second activation to run cycle	Defective (Instant Start) ice cube relay	Replace ice cube relay P/N: 00631.00
Pressing and holding fill switch does not fill machine	Defective drain/fill switch	Replace drain/fill switch P/N: 15522.00
	Defective water solenoid valve	Replace water solenoid valve P/N: 00705.00
Fill (rinse water) won't shut off	Defective water solenoid valve	Replace water solenoid valve P/N: 00705.00
	Defective drain/fill switch	Replace drain/fill switch P/N: 15522.00
	Defective timer assembly	Replace timer assembly* P/N: 14408.80
	Defective (Rinse Relay) ice cube relay	Replace ice cube relay P/N: 00631.00
Pressing and holding drain switch does not drain machine	Drain hose is kinked	Un-kink drain hose
	Defective drain/fill switch	Replace drain/fill switch P/N: 15522.00
	Defective drain valve	Replace drain valve P/N: 04103.00
Cycle light does not light while cycle runs	Defective cycle light	Replace cycle light (green) P/N: 00406.60
Power light does not light but machine runs	Defective power light	Replace power light (red) P/N: 00406.00
Wash tank or final rinse temperature does not display	Defective digital thermometer	Replace digital thermometer P/N: 03202.45
Both the wash tank temperature and the final rinse temperature do not display	Defective thermometer transformer	Replace thermometer transformer P/N: 03202.60
Wash tank or final rinse displays wrong temperature	Defective digital thermometer	Replace digital thermometer P/N: 03202.45
	Defective thermister	Replace thermister P/N: 03202.65

4. Parts Kit

4.1. Initial Parts Kit (P/N 1100.66)

P/N	DESCRIPTION	Qty
15504.00	Motor Contactor, 2-Pole 20 Amp	1
15504.50	Heater Contactor, 2-Pole 35 Amp	1
00501.00	2-Minute Timer Motor	1
00631.00	Ice Cube Relay 120 V	1
00707.00	½ Water Solenoid Repair Kit JE	1
00738.15	Solenoid Coil JE 220V	1
15523.00	Rocker Switch Start Momentary	1
15523.50	Rocker Switch Drain/Fill	1
15524.00	Rocker Switch Power Maintained	1
00556.10	Reed Switch	1
03623.00	1/2" Vacuum Breaker Repair Kit – Watts	1
00707.00	1/2" Water Solenoid Repair Kit – J/E	1
04113.00	L1X/L1-C Drain Valve 120V	1
00206.70	Pump Seal Kit	1
13417.89	Heater Thermostat	1
17523.60	High Limit Switch 200°F	1
00411.00	Microswitch	1
03203.01	Dual Temperature Display Kit	1
00738.15	Solenoid Coil JE 115V/60Hz	1

4.2. Drain Pump

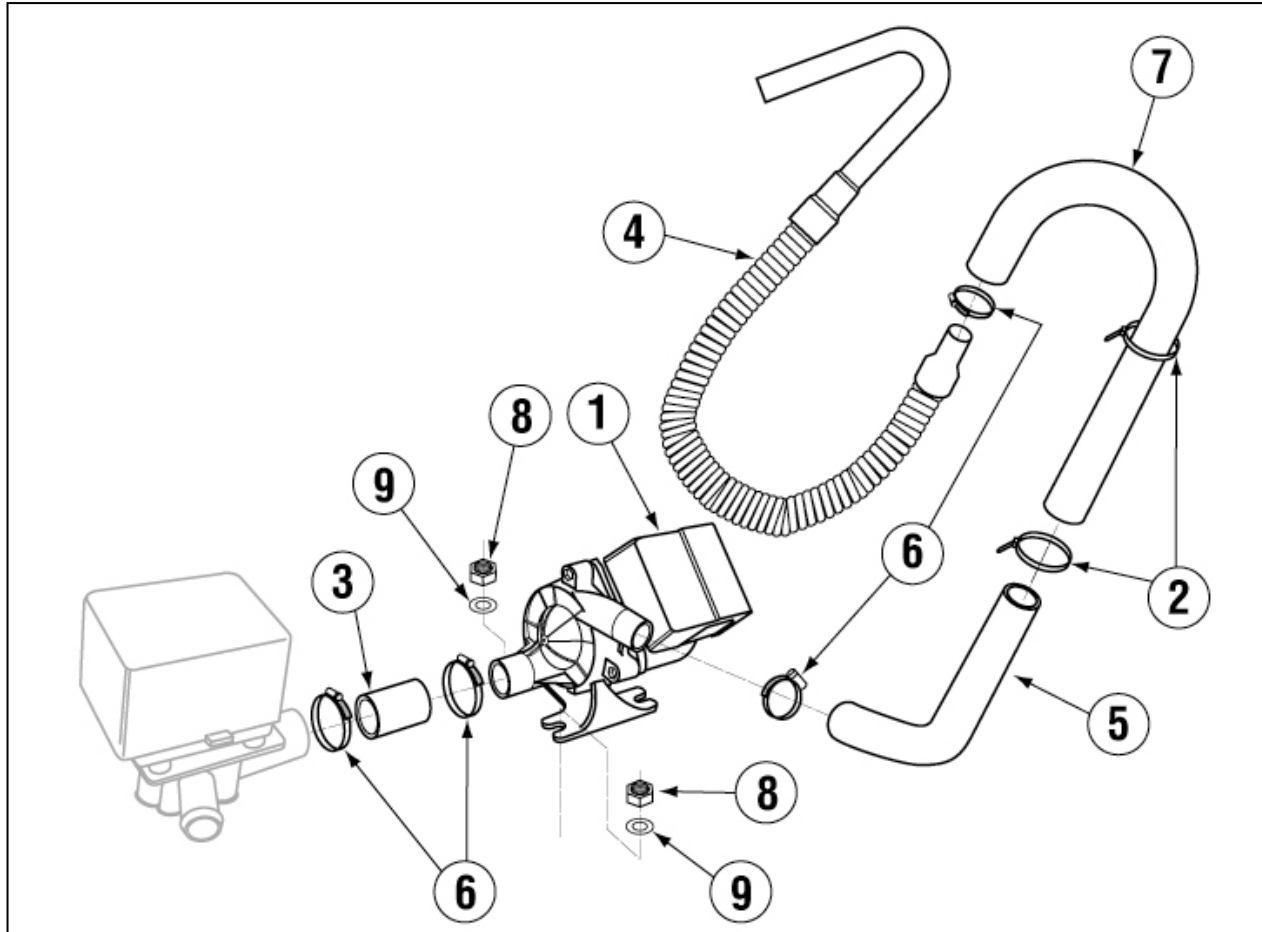

ITEM NO.	NO. REQ'D	P/N	DESCRIPTION
1	1	15503.00	Drain Motor Ultra Jet for CMA-180UC
2	2	00932.50	Twist Tie
3	1	15601.10	Black Drain Hose 1" ID X 3 1/2"
4	1	15605.00	Drain Hose with Goose Neck
5	1	15601.60	Robber Hose 90 Deg.

ITEM NO.	NO. REQ'D	P/N	DESCRIPTION
6	4	03101.00	Hose Clamp 1"
7	1	15603.00	Drain Line Gooseneck
8	2	03801.10	10-32 SS Nut
9	2	04806.00	#10 Brass Washer

4.3. Drain Pump Removal Instructions

Drain Pump (P/N 15503.00) should only be used if a floor drain is not accessible to the machine at installation.

When converting the UC-180 dishwasher to a gravity drain unit, remove the drain pump assembly as shown in **Figure 1**. Re-route the 6Ft drain hose to the center port were the drain pump was located, moving the displaced line to the open port of the valve. Insure there is a 1" air gap between the discharge and floor drain as shown in **Figure 2**.

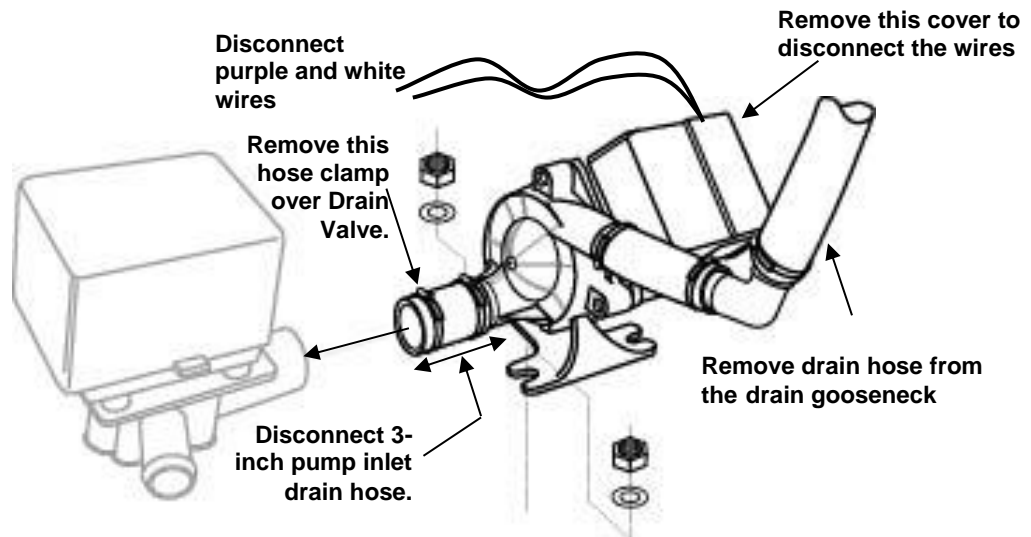

Figure 1

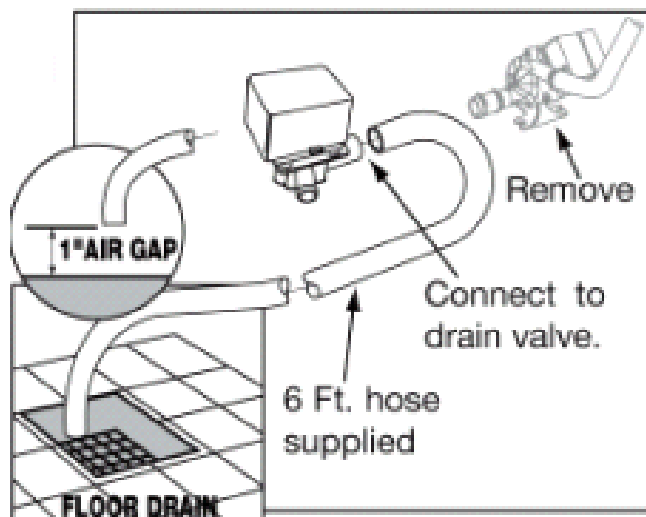

Figure 2

5. Customer Notice

CMA-180UC Installation Guidelines

Improper installation of this product may void the warranty on this machine. Please follow these guidelines for recommended installation and to ensure the warranty of this model is authorized by CMA Dishmachines.

Dishmachine Installation Requirements

1. Machine **must** be level. Adjust leveling feet to accommodate uneven floor surfaces.
2. Stand pipe drain height should not exceed maximum height of 22". If there is a floor drain, it is highly recommended the pump drain be removed. Connect supplied drain line to 3-way valve on back of machine and gravity feed to the floor drain.
3. Approximately 4-feet of $\frac{3}{4}$ " flexible conduit with power leads (L-1, L-2, Neutral and Ground) extending out of the conduit are provided for easily connecting the power at installation. CMA recommends a minimum 50-amp dedicated circuit, but you should consult your local building code requirements for proper breaker size.

Activating/Adjusting the Booster Heater

1. Booster heater **must** be filled with water prior to connecting the blue wire from high limit switch. The high limit switch can be found by removing the front panel and locating the red button on the front of the heater tank.
2. Once the booster has been connected, the thermostat should be adjusted to maintain 180°F during the final rinse cycle. The thermostat is located on the front of the booster tank and is accessible by removing the front panel on the machine.

Automatic Dispensing Equipment

Applications utilizing automated dispensers for administering warewash chemicals must use 110v dispenser equipment. There is a 110v power block for installing this equipment inside the control panel.

Diagrams

6. Electrical Diagrams

CMA-180UC ELECTRICAL DIAGRAM
POWER BOX

7-24-08

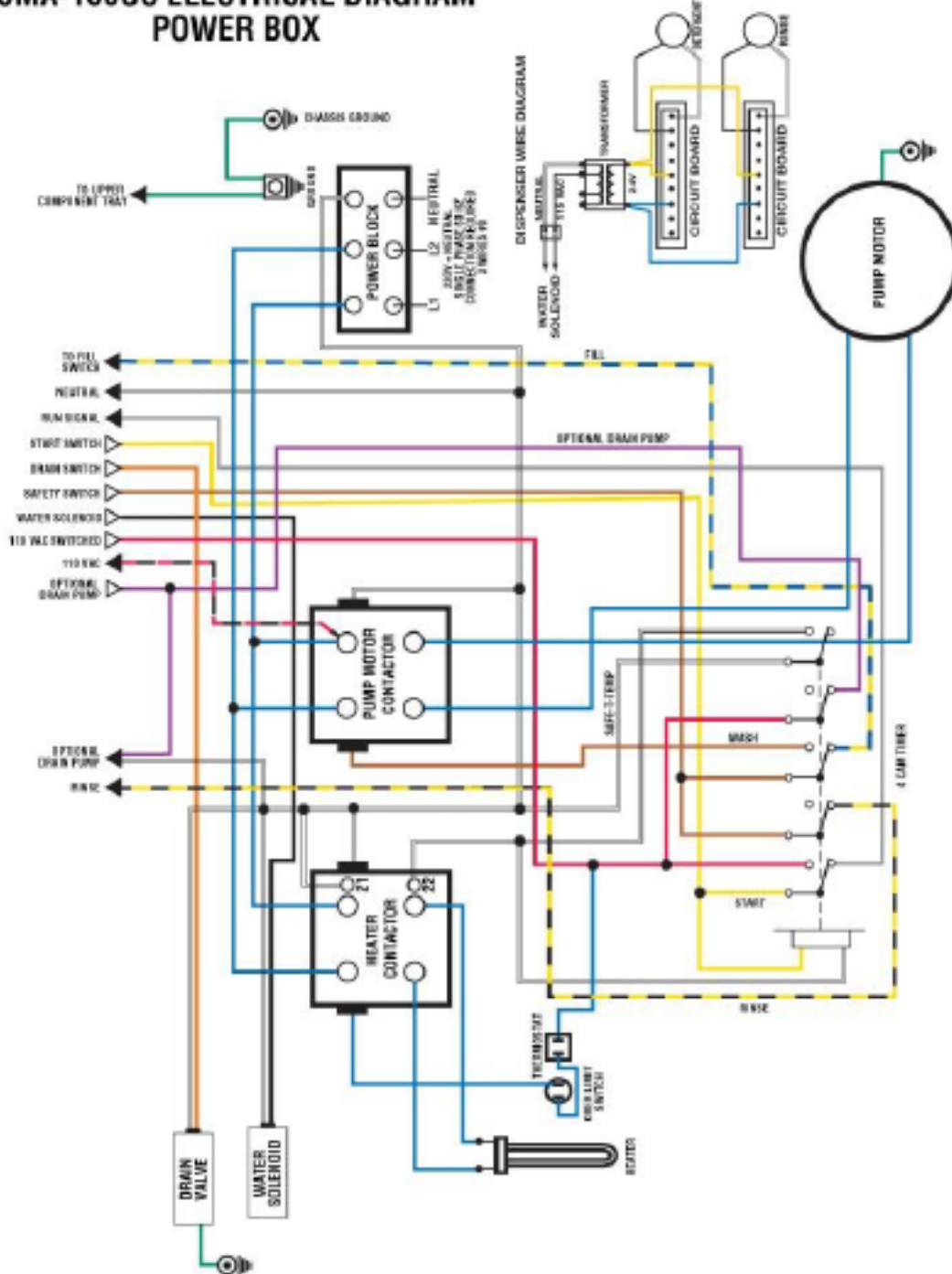

Diagrams

CMA-180UC ELECTRICAL DIAGRAM CONTROL PANEL

Rev.12-2016

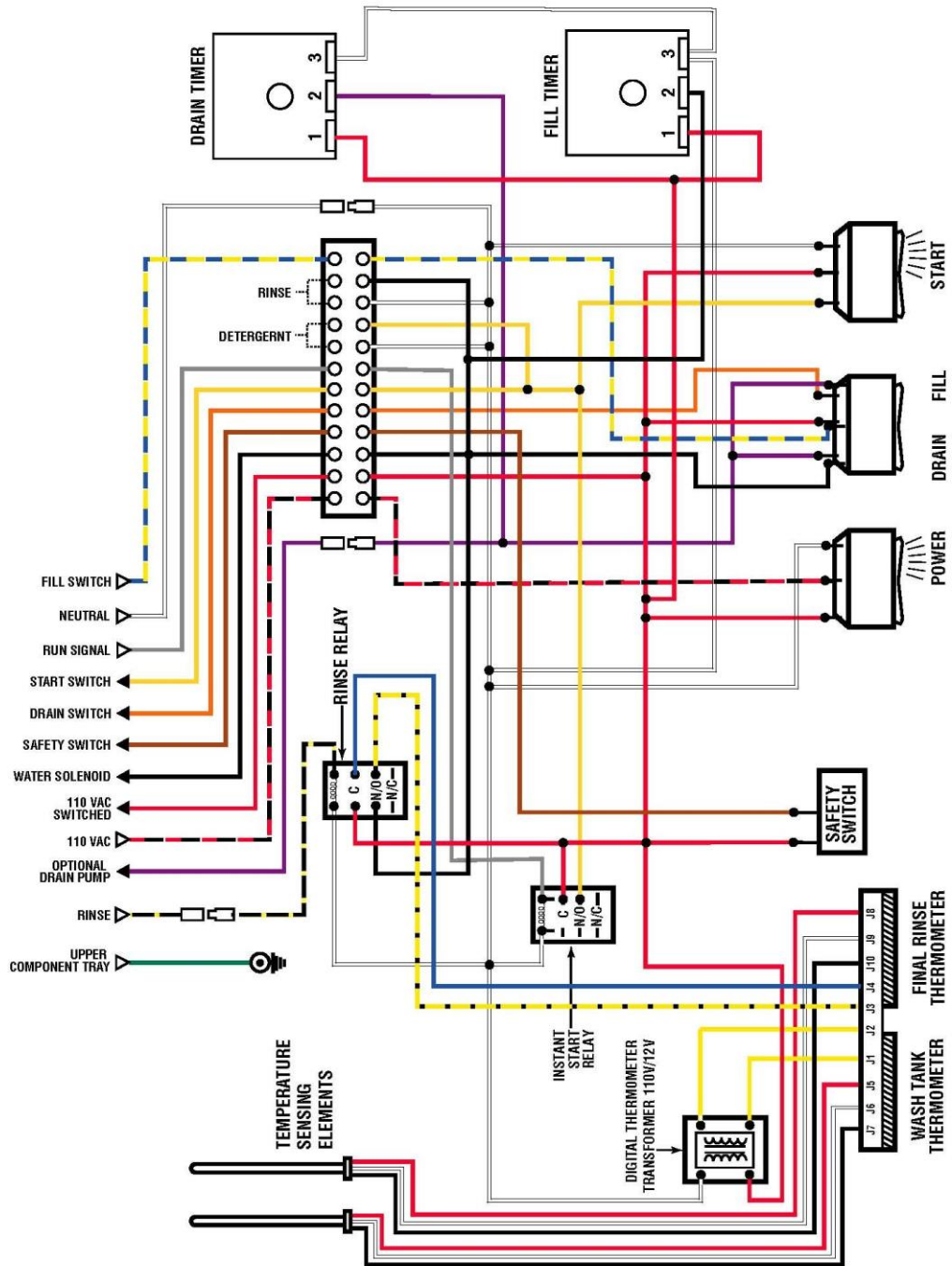

Diagrams

CMA-180 UC ELECTRICAL DIAGRAM
POWER TRAY

Rev. 3.00
10/28/19

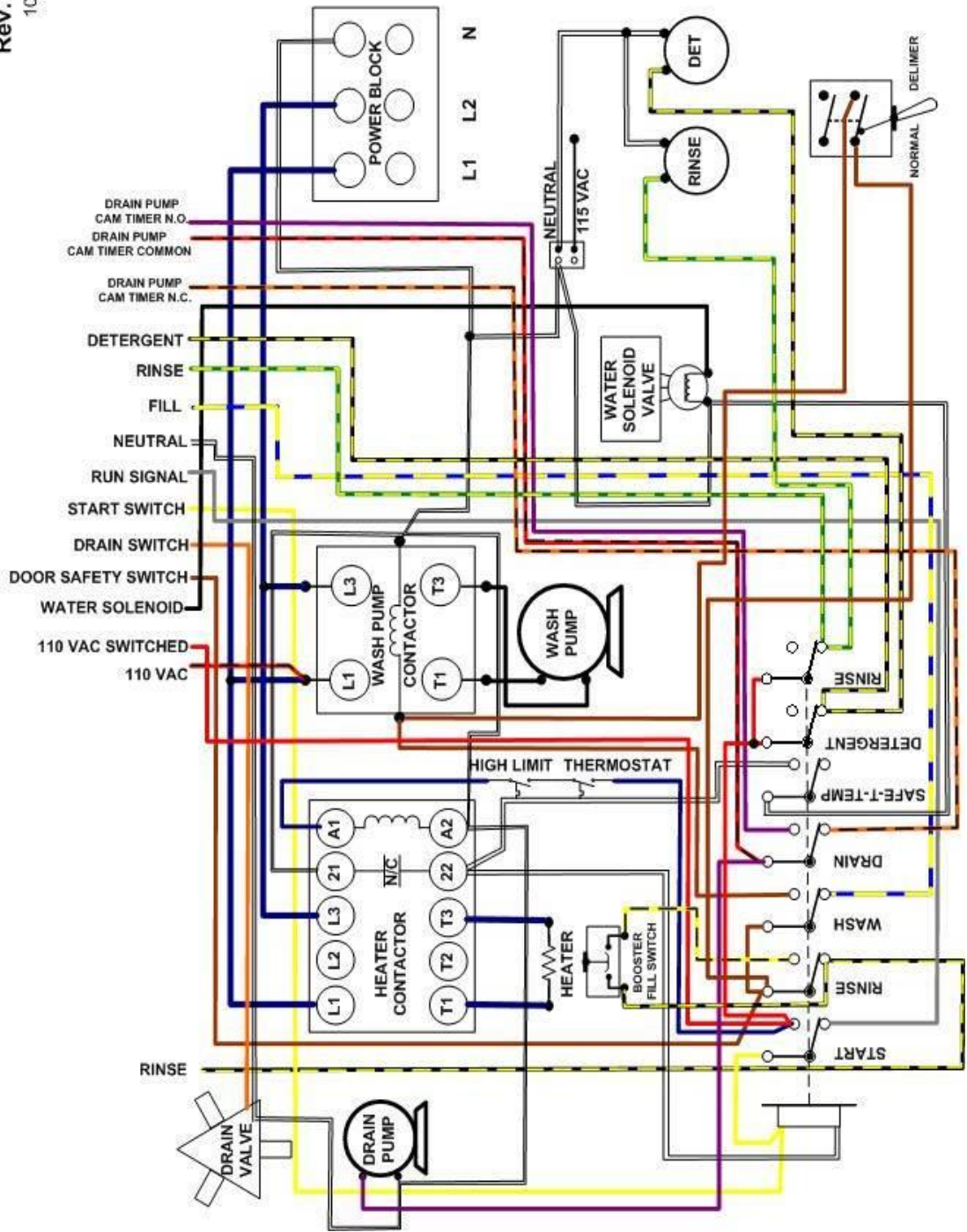

Diagrams

Effective January 2018 to January 2020.

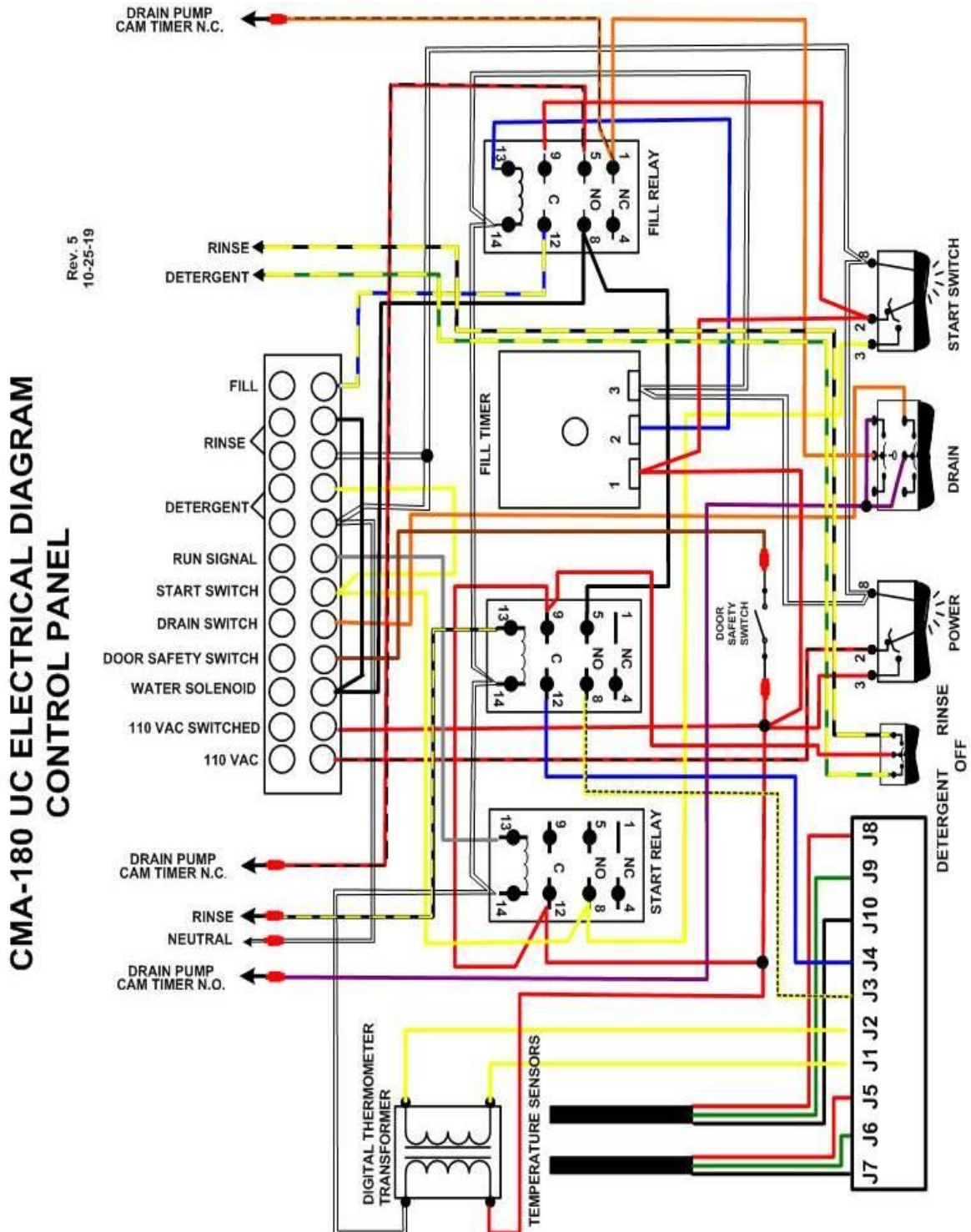

Diagrams

Rev. 4.00
12/11/19

Effective January 2020.

CMA-180 UC ELECTRICAL DIAGRAM
POWER TRAY

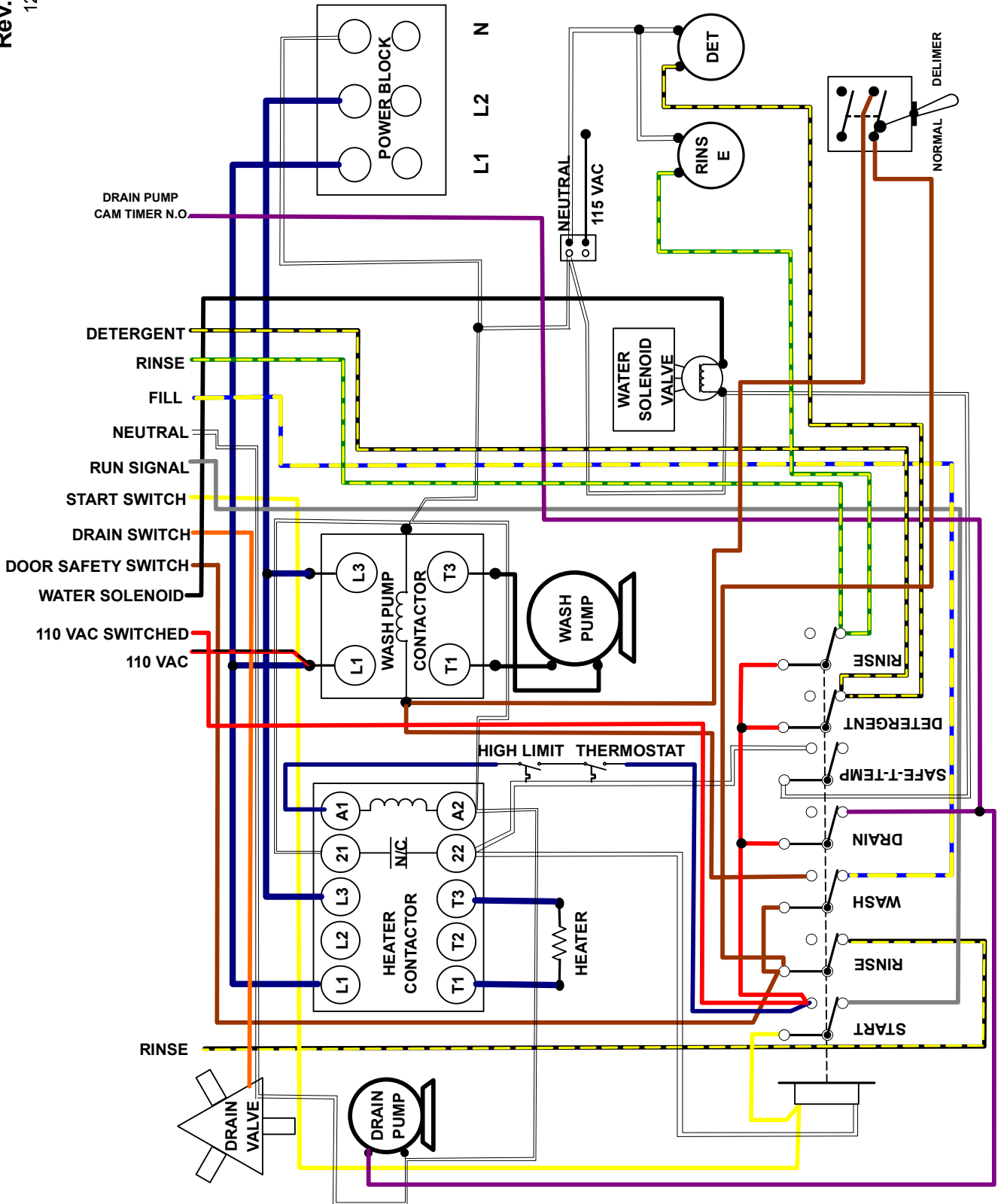

Diagrams

Effective January 2020.

CMA-180 UC ELECTRICAL DIAGRAM CONTROL PANEL

Rev. 7
12-12-19

