

MODEL EST44

SERVICE AND PARTS MANUAL

Rev.2.08A
12-17-19



CMA DISHMACHINES
12700 KNOTT STREET
GARDEN GROVE
CALIFORNIA 92841

800-854-6417

FAX 714-895-2141



Table of Contents

EST-44

1. SPECIFICATIONS.....	2
1.1. EST- 44.....	2
2. GETTING STARTED	3
2.1. Introduction to CMA Model EST -44.....	3
2.2. Receiving and Installation	4
2.2.1. <i>Box Item List</i>	4
2.2.2. <i>Electrical</i>	5
2.2.2.1. Control Box Components	6
2.2.3. <i>Plumbing</i>	7
2.2.4. <i>Scrap Tray Assembly Installation</i>	9
2.2.5. <i>Conveyor Drive/ Rack Speed</i>	10
2.2.6. <i>Wash Pump Assembly and Impeller</i>	11
2.2.7. <i>Table Limit Switch Installation</i>	12
2.2.8. <i>Optional Vent Hood Adapter's Installation</i>	13
2.2.9. <i>Chemical Dispenser Connection</i>	14
2.2.10. <i>Optional Exhaust Fan Control P/N 13578.00</i>	14
2.2.11. <i>(Optional) E-Temp Booster Heater</i>	15
2.3. EST-44 Safety Tips	16
3. OPERATION	17
3.1. Beginning Operation.....	17
3.2. Cleaning Instructions	19
3.3. Regular Service and Maintenance Checklist	20
3.4. Trouble Shooting	21
4. EST-44/66 CUSTOMER NOTICE.....	3
5. PARTS MANUAL	5
5.1. Initial Parts Kit	5
5.2. Exploded View Drawings.....	6
5.2.1. <i>Cabinet Assembly</i>	6
5.2.2. <i>Control Box Assembly (3 Phase)</i>	7
5.2.1. <i>Control Box Assembly (1 Phase)</i>	8
5.2.2. <i>480V Control Box Assembly (480V machines only)</i>	9
5.2.3. <i>Curtain and Optional Vent System</i>	10
5.2.4. <i>Old Wash Temperature Control System (Square Flange)</i>	11
5.2.5. <i>New Wash Temperature Control System (Triangular Flange)</i>	12
5.2.6. <i>Rinse Temperature Control System</i>	13

5.2.7.	Wash Pump Assembly (3 Phase).....	14
5.2.8.	Wash Pump Assembly (1 Phase).....	15
5.2.9.	Power Rinse Pump Assembly.....	16
5.2.10.	Drain System Assembly.....	17
5.2.11.	Plumbing System Assembly (Auto-Fill)	18
5.2.12.	Plumbing System Assembly (Final Rinse).....	19
5.2.13.	Wash System Assembly	20
5.2.14.	Rocker Arm Assembly	21
5.2.15.	Start Switch and Rinse Switch Assembly (Effective May 2014)	22
5.2.15.1.	Right-to-Left Assembly	22
5.2.15.2.	Left-to-Right Assembly	23
5.2.16.	Start Switch and Rinse Switch Assembly	24
5.2.17.	Door Switch Assembly (Effective August, 2014).....	25
5.2.18.	Optional E-Temp Heater (Effective September 1, 2018).....	26
5.2.19.	Optional E-Temp Heater	27
5.2.20.	Unique Parts For EST-44 Tall machines.....	28
6.	TABLE LIMIT SWITCH (P/N 13469.20)	29
7.	DRAIN WATER TEMPERING KIT (OPTIONAL)	30 & 31
8.	ELECTRICAL DIAGRAM FOR 240V, 3 PHASE EST-44	32
9.	ELECTRICAL DIAGRAM FOR E-TEMP HEATER ONLY.....	33
10.	ELECTRICAL DIAGRAM FOR 480V EST-44.....	34
11.	ELECTRICAL DIAGRAM FOR 240V,1 PHASE EST-44	34 & 35

1. Specifications

1.1. EST- 44

	Low Temp	High temp		
WATER CONSUMPTION				
PER RACK (FINAL RINSE)	.46 GAL.	.46 GAL.		
PER HOUR (FINAL RINSE)	114 GAL.	114 GAL.		
CONVEYOR SPEED				
FEET PER MINUTE	6.75	6.75		
OPERATING CAPACITY				
RACKS PER HOUR (NSF rated)	249	249		
OPERATING TEMPERATURE				
WASH RECOMMENDED	140° - 150° F	150° - 160° F		
PUMPED RINSE RECOMMENDED	140° - 150° F	150° - 160° F		
FINAL RINSE RECOMMENDED	140° - 150° F	180° - 195° F		
WATER REQUIREMENTS				
INLET TEMPERATURE (MIN)	140° F	180° F		
WATER INLET SIZE		1/2"		
FINAL RINSE SIZE		1/2"		
DRAIN SIZE		2"		
FINAL RINSE PRESSURE		20 PSI		
HEATERS				
WASH HEATER	13.3 KW/240V(1 phase) 13KW/208V(3 phase)			
RINSE HEATER	3KW/240V, 2.25KW/208V			
MOTORS				
WASH PUMP		1 HP		
RINSE PUMP		1/3 HP		
CONVEYOR		1/8 HP		
DIMENSIONS				
DEPTH		25-1/8"		
WIDTH		44"		
HEIGHT		55 -1/2"-56-1/2"		
STANDARD TABLE HEIGHT		32 1/2" adjusts to 34"		
MAX CLEARANCE FOR DISHES		19"		
VENTILATION REQUIREMENTS CFM	600 Total, 400 clean side, 200 soil side			
STANDARD RACKS				
	VOLTS	PHASE	AMPS	AMPS(Tall)
ELECTRICAL RATING	208	1	71	N/A
	240	1	80	N/A
	208	3	55	60.5
	240	3	62.5	69
	480	3	24	27
SHIPPING WEIGHT		662#		(300kg)



2. Getting Started

2.1. Introduction to CMA Model EST -44

The **EST** is designed to give maximum cleaning in 44 inches. It represents the cleaning power of machines twice its length. The curtains incorporated in the dishwasher minimize the transfer of water from tank to tank during the wash and sanitizing procedures.

The energy costs for running the **new EST-44** have been greatly reduced, by the introduction of our **new Stage Washing Process**. The EST-44 Conveyor dishwasher lowers gallon/rack ratings and is directly related to CMA's **new Power-Rinse Stage** that has been introduced. The EST-44 **new Re-circulating Wash** and **new Power-Rinse Stage** greatly reduce the amount of chemicals being used, thus adding a significant cost reduction and energy efficiency to its' operation.

The EST-44 can be used as a high or low temperature dishwasher, with the new wash tank and power rinse tank designs, both having their own re-circulating pumps. The Power Rinse Stage provides a fresh cleansing rinse, before the dish rack advances into the *Power Rinse and Fresh Water* and Sanitizing Rinse Stages.

The initial-fill water and the final rinse water that is supplied to the EST-44 must be a minimum of 140°F, in low-temperature applications, while high-temperature machines will require two water lines; one at a minimum water temperature of 140°F to fill the dishwasher, and the second with a minimum of 180°F for the final rinse. With the introduction of the **new optional E-Temp Booster Heater**, it will be offered fully integrated to the dishwasher.

The EST-44 also features a stainless steel scrap accumulator tank and tray, which must be emptied on a periodic basis, as necessary. The EST machine is designed to deliver 0.49 gallons of fresh rinse water for each rack. This water flows from the rinse and power-rinse tanks into the wash tank, and then overflows into the scrap tray, carrying any debris that may have fallen into the wash tank, thereby providing a much cleaner environment for the washed and rinsed dishes. If preferred, there are also options such as a Corner Feed System, optional Vent Hood Adapters, Exhaust Fan Control Circuits and a Drain Tempering Kit. CMA also offers a full line of other machine accessories, including stainless steel dishtables. (See equipment catalog)

DISCLAIMERS

CMA expressly disclaims any and all warranties, express or implied, relating to the installation of any and all CMA equipment that is installed by chemical dealers, contracted servicers or third party servicers to CMA equipment. If the installation instructions are not followed exactly (to the letter), or, if any person or company conducting the installation of the CMA equipment, revise the installation procedures or alter the instructions in any manner, the CMA warranty becomes void. If, due to the improper installation of CMA equipment, this equipment ceases to operate properly or affects other parts of the CMA dishwashing equipment, in that the other parts become defective, the CMA warranty becomes void. CMA will not be liable or responsible or warrant CMA equipment, due to improper installation of any CMA model dishwasher.

CMA does **NOT** endorse "Tankless On-Demand" water heaters for use on CMA Dishmachine products. On most applications, the volume of hot water required for commercial dishmachines exceeds the capacity of these types of heating sources. You will find that most, if not all, commercial dishmachines have been programmed with auto-filling features that require quick filling, with a designated limited time.

CMA **DOES** endorse, and highly recommends, the standard "tank" style water heaters, sized properly to handle each particular facility with their water heating requirements. A "tank" style water heater stores and supplies a large capacity of preheated water before providing hot water to the dishmachine. To meet required health codes, there must be a reliable and consistent flow of adequate hot water supplied to the dishmachine. If the facilities' "tank" style water heater is marginal in size, CMA recommends installing a proper size Hatco Booster Heater, a CMA's E-Temp 40 or 70-degree-rise Booster Heater (that can be installed on CMA Conveyors), or a CMA Temp-Sure Booster Heater (for door and undercounter dishmachines). All are designed to adequately achieve results.

Important: Make sure incoming power supply corresponds to the voltage listed on the data plate. If the voltage is too low (206V or less), the heating elements will not reach desired temperature specified by manufacturer, and performance will be compromised. The heating element needs to be sized according to the facilities available voltage, which must be noted on your purchase order to CMA for a special dishmachine. Special lower voltage higher kilowatt heaters are available upon request. Make sure a fused disconnect switch or circuit breaker (not supplied) is installed in the electrical service lines supplying this dishwasher and should meet the requirements of your local electrical code.

2.2. Receiving and Installation

2.2.1. Box Item List

When you receive your new EST-44, prior to installation of the dishwasher, remove the box containing the all items needed for the installation. (See item list below)

- Literature & Manuals
- Instructional Operation Video
- Scrap Tank Assembly, w/Mounting Bracket
- Curtains Interior and Exterior, w/Rods
- Exterior Wrapper Shields
- Installation Hardware
- Operation Wall Chart
- Optional Vent Hood Adapters when ordered.

Start by first installing the Scrap Tray Assembly (see **Scrap Tray Assembly, Section 2.2.4**), along with the Overflow Chute, then the two wrapper shields and the exterior and interior curtains and rods, which are shipped inside the machine. All of the wash-arms are fully installed over the wash and power-rinse tanks. There are a total of three curtains used in the EST-44: two long-exterior curtains and one short-interior curtain, all with their own curtain rods. (See Figure 2.2-1, below)

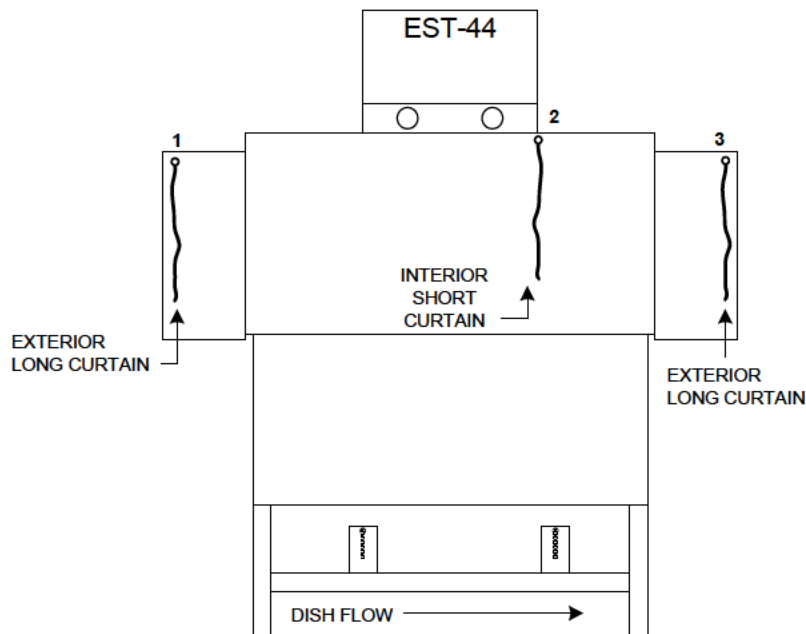

DISHMACHINE FRONT VIEW

Figure 2.2.1

2.2.2. Electrical*

The CMA Model EST-44 Conveyor can be ordered as Single-Phase or Three-Phase, using 208v to 240v. The machine **must** be connected to a dedicated circuit. (See Figure 2.2.2 below for amp draw). When installing a Three-Phase machine, check the voltage on all three incoming lines, and place the highest leg on the **L2** terminal. (This is called a high-leg, stinger-leg, or Wild-leg.)

Prior to installation make sure the electrical supply is compatible with the specifications on the machines data plate.

WARNING: Electrical and grounding connections must comply with the applicable portions of the National Electrical Code and/or other local electrical codes.

Note: For supply connections, use copper wire only rated at 90 degree C minimum.

Warning: To prevent excessive overloads and component damages, it is essential for the Dispenser Power Supply to be wired to the supplied Power Block on all conveyors. The CMA-supplied power block has been pre-wired to the wash heater contactor L1 and L3 terminals, to assure a correctly balanced power, as well as accurate surrounding components.

Only for dispensers requiring constant power, connect to **L1** and **L3** of main contactor; otherwise, use the Dispenser Power Block that has been provided.

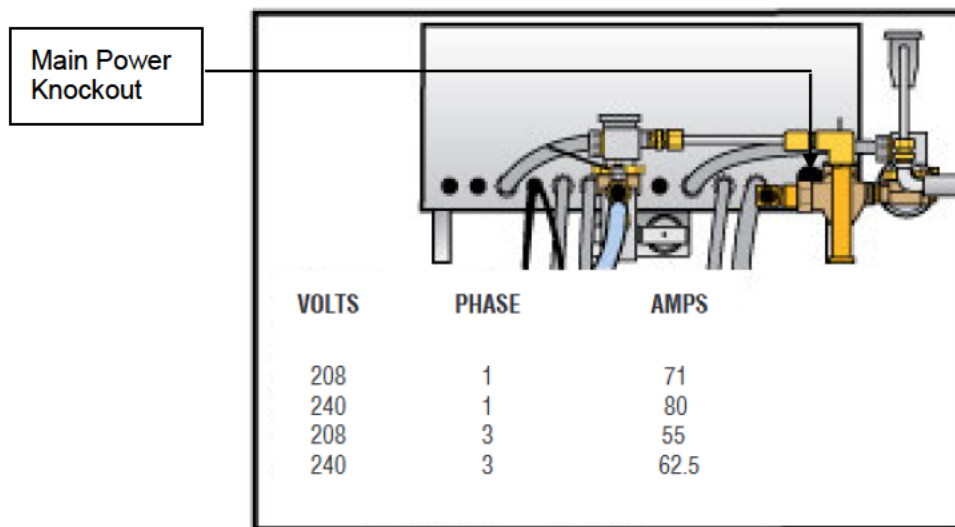

Figure 2.2.2

On a 3-phase machine the water pump motors are also 3-phase and, depending on the terminal that each phase is connected to, the motor can rotate in either direction. Check the direction of rotation by removing the dust cap on the back of the motor. The motors must turn clockwise, when looking at the shaft from the back of each motor. To change the direction of rotation, switch any two power lead wires at the motor.

DANGER: ALWAYS TURN OFF THE DISHWASHER'S MAIN POWER SUPPLY BEFORE SERVICING THE DISHWASHER. ALTHOUGH THE MACHINE'S MAIN POWER SWITCH IS "OFF", THE MAIN CONTACTOR LEADS WILL STILL HOLD VOLTAGE.

* Electrical and plumbing connections must be made by a qualified person who will comply with all available Federal, State, and Local Health, Electrical, Plumbing and Safety codes

2.2.2.1. Control Box Components

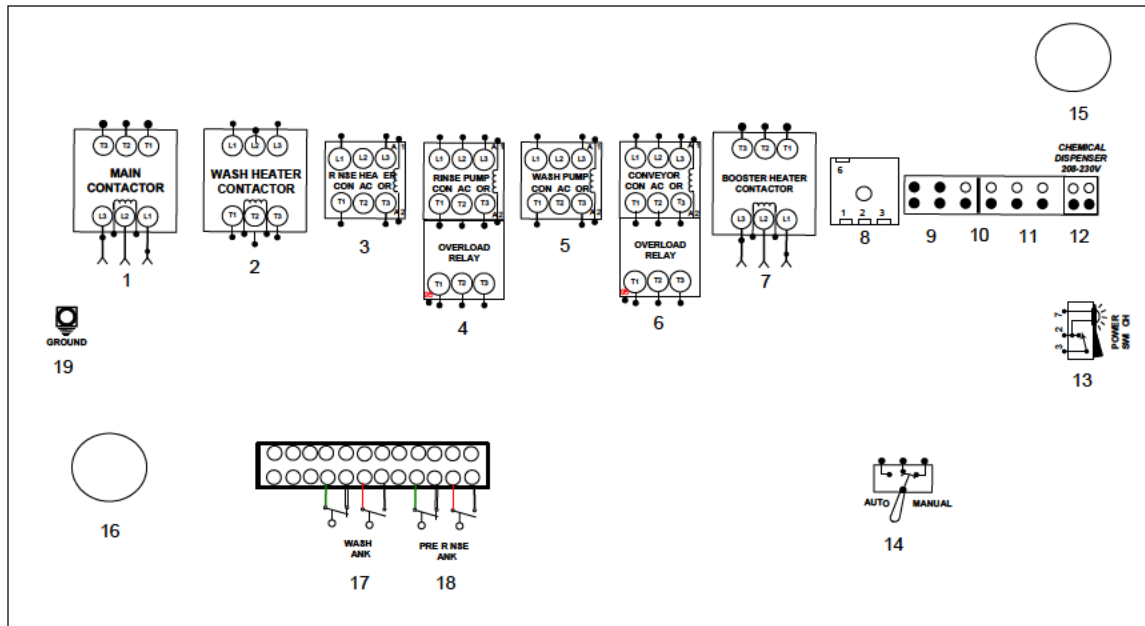

- | | |
|---|--------------------------------------|
| 1. Main Contactor | 11. Detergent Terminals |
| 2. Wash Tank Heater Contactor | 12. Dispenser Power Supply Terminals |
| 3. Power Rinse Heater Contactor | 13. On-Off Power Switch |
| 4. Power Rinse Motor Contactor w/overload | 14. Auto/Manual Switch |
| 5. Wash Pump Contactor | 15. E-Temp Power Cable Knockout |
| 6. Conveyor Contactor w/overload | 16. Main Power Knockout |
| 7. E-Temp Heater Contactor (Optional) | 17. Wash Tank Float Terminals |
| 8. Conveyor Timer | 18. Power Rise Float Terminals |
| 9. Table Limit Switch Terminals | 19. Ground Terminal |
| 10. Sanitizer/Rinse Terminal Terminals | |

2.2.3. Plumbing*

Note: The required flowing water pressure to the dishwasher is 15-65 PSIG. If pressures higher than 65 PSIG are present, a pressure regulating valve must be installed in the water line to the dishwasher (by others). If flowing pressure is lower than 15 psi, improper machine operation may result.

Notice to Plumber: The plumber connecting this machine is responsible for making certain that the water lines are THOROUGHLY FLUSHED OUT BEFORE connecting to the dishwasher.

Ask your municipal water supplier for details about your local water conditions prior to installation. Recommended water hardness is 3 grains per gallon or less.

Note: high iron levels in the water supply can cause staining and may require an iron filter. High chlorine levels in the water supply can cause pitting and may require a chloride removal system. If an inspection of the dishwasher or booster heater reveals lime buildup after the equipment has been in service, water treatment is recommended. If water softener is already in place, ensure there is a sufficient level of salt.

The water supply connection is made with two ½" hot water lines; the valves are located at the top of the machine, behind the main control box. The water supplied to the machine must be a minimum of 140° F to the main fill valve and a minimum of 180° F to 195° F for a high temperature final rinse, with no more than 140° F for a lower temperature final rinse. (See Figure 2.2.3a below)

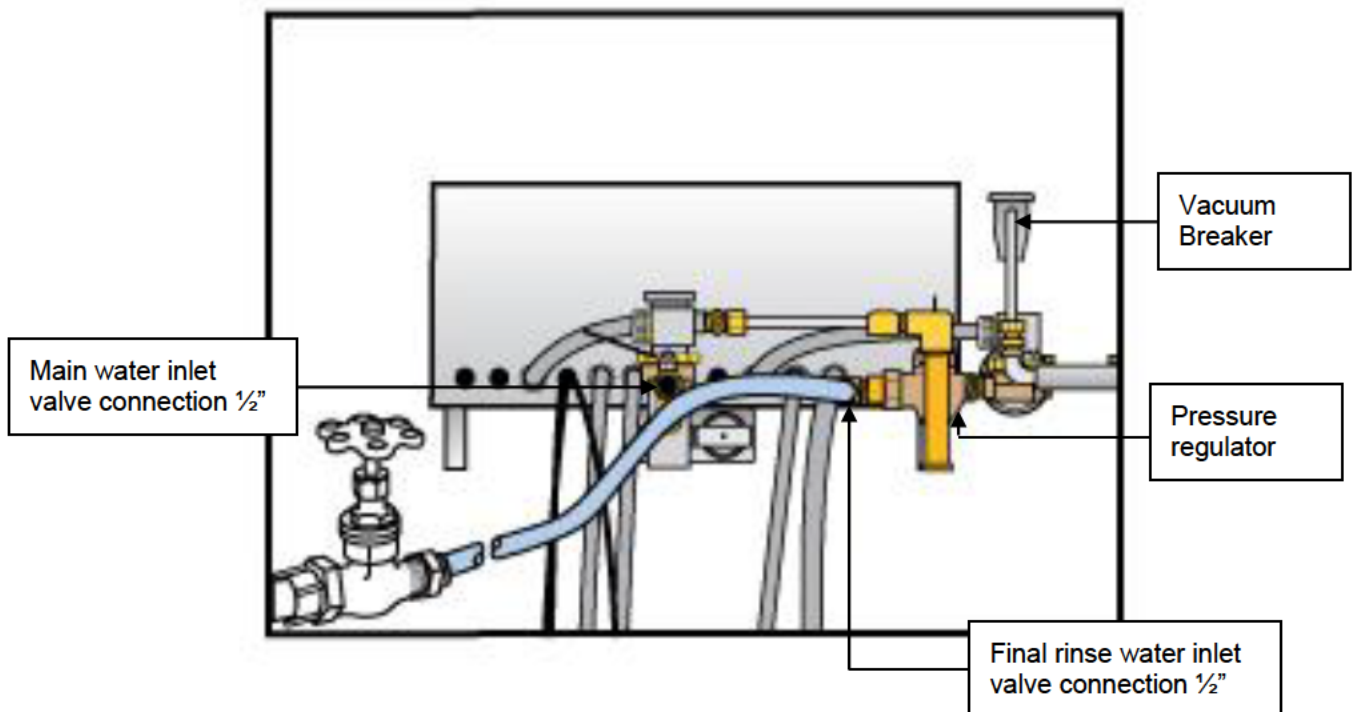

Figure 2.2.3a

To set the final rinse pressure, the final rinse must be running. Turn the adjustment screw clockwise to increase final rinse pressure; and counter-clockwise to decrease the pressure set the final rinse pressure to 20-psi ±5 psi. (Set to 22 - 23 psi for optimum running pressure)

* Electrical and plumbing connections must be made by a qualified person who will comply with all available Federal, State, and Local Health, Electrical, Plumbing and Safety codes

Getting Started

There are two 2" drain openings off both ends of the dishwasher, however only one connection is on the horizontal drainpipe. Place the 2" drain plug, supplied in the end of the pipe not being connected to the drain line (See Figure 2.2.3.b below).

Note: One of the ends of the horizontal drainpipe has a stopper cap on it – simply move the cap to the other end, if it's currently on the end needed for the drain connection.

The Scrap Tray Assembly is placed inside the machine for shipping. Follow the instructions provided in 2.2.4 Scrap Tray Assembly to properly install to the dishmachine.

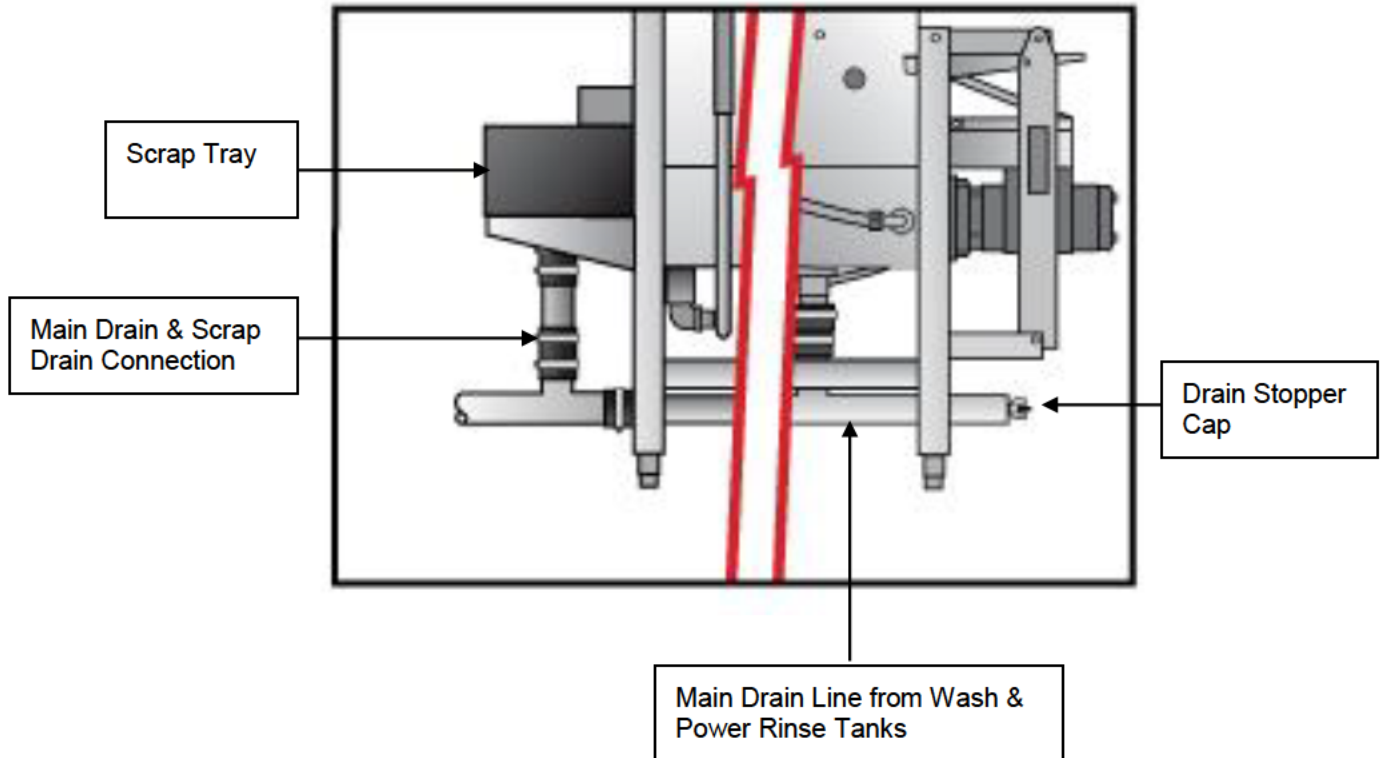

Figure 2.2.3b

2.2.4. Scrap Tray Assembly Installation

The Scrap Tray Assembly and Overflow Chute, which were shipped inside the machine, can easily be installed by executing the following steps: **Figure 2.2.4** below illustrates the assembly, as it would appear for a Left-to-Right machine – (a Right-to-Left machine would simply be the mirror image).

Caution:

1. For proper spacing, the SS flat washer must *not* be located between the head of the truss head bolt and the inside of the machine.
2. The illustration below shows the correct placements of the scrap trap holder. Do not install upside down, otherwise water deflection takes place.

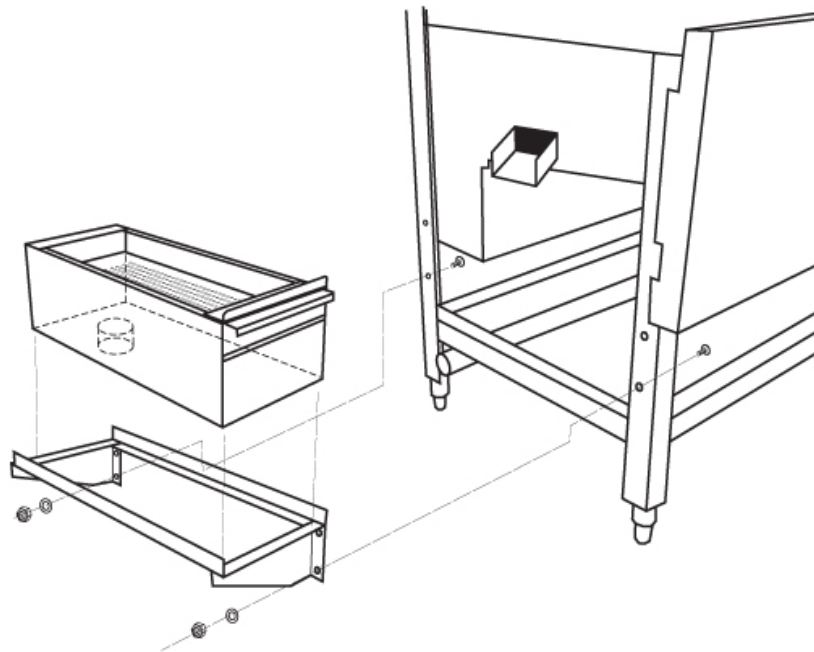

Figure 2.2.4

1. Remove items from their packaging and verify that all “installation hardware” was included.
2. Secure the scrap trap holder to the dishmachine by using the four ¼-20 X ½” Hex Head Bolts, the ¼” SS Flat Washers, and the ¼”-20 Nylon Lock Nuts that were provided.
3. Set the scrap trap body—with the scrap trap drawer inserted—into position on the scrap trap holder. (Attach the drain as specified in Section 2.2.3)

2.2.5. Conveyor Drive/ Rack Speed

The Conveyor Drive Cam below shows the two different conveyor drive cam speed settings; for standard 243 Racks/Hour and a slower 205 Racks/Hour (See Figure 2.2.5). By changing the Drive Cam Bearing location, the racks will travel through the machine slower.

Note: If the dishwasher is being used in a very heavy soil environment, changing the rack speed to 205 racks/hour will slow down the racks as they pass-through the dishwasher, allowing them to receive more chemical and water “contact time”.

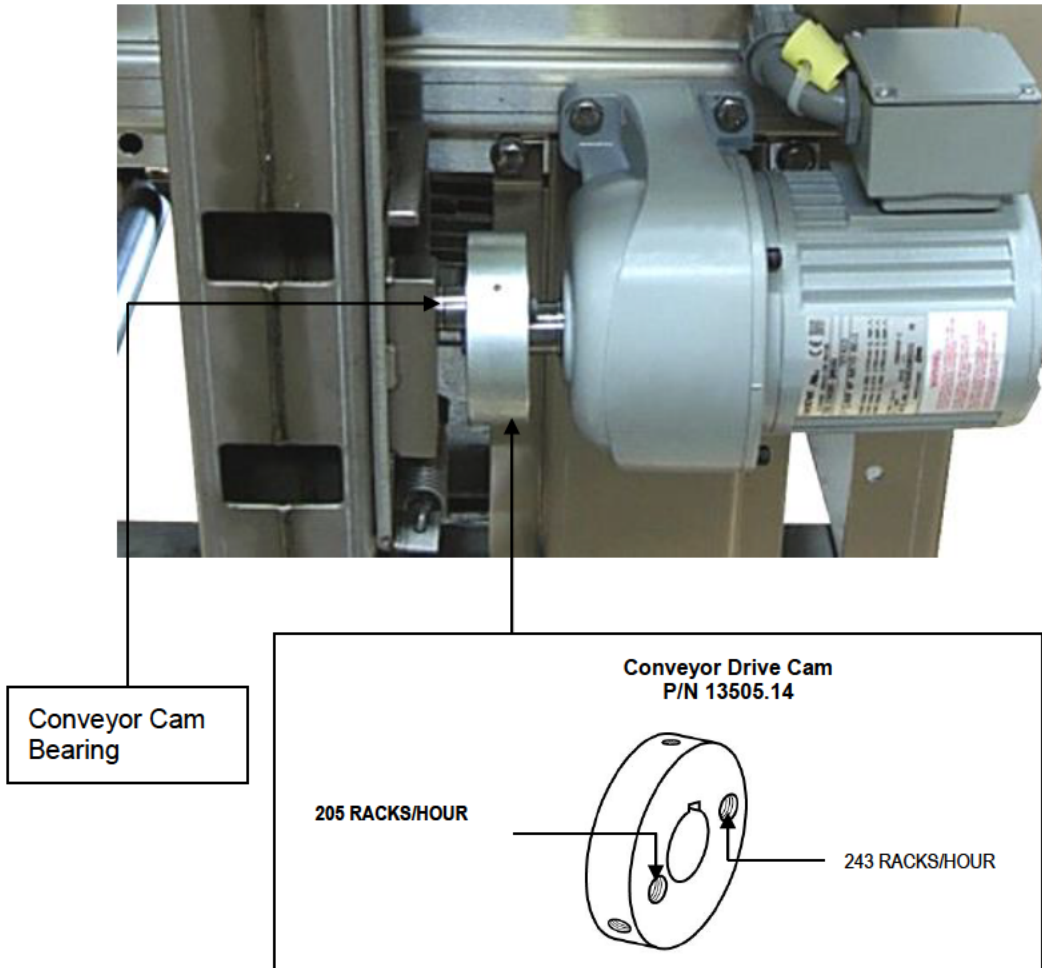

Figure 2.2.5

Caution: DO NOT GET IN THE PATH OF THE CONVEYER DRIVE ASSEMBLY, ROCKER ARM, OR CONVEYOR BAR, WHILE MACHINE IS IN OPERATION. DO NOT REACH INTO THE ROCKER ARM ASSEMBLY WITHOUT FIRST MAKING SURE THE DISHWASHER IS TURNED “OFF” AT THE MAIN PANEL. EVEN WITH THE MACHINE’S POWER SWITCH “OFF”, THE MAIN CONTACTOR LEADS WILL STILL CARRY VOLTAGE.

2.2.6. Wash Pump Assembly and Impeller

The standard wash pump motor is three-phase and can operate clockwise, as well as counter-clockwise; the **Nylon Lock Nut** used to hold the impeller in place (See Figure 2.2.6), is very important. When servicing the Wash Pump Assembly and replacing the seals, make sure it is secured properly; otherwise, if the motor turns the wrong direction, the impeller may spin-off the motor shaft causing damage to the impeller.

Note: ALWAYS CHECK THAT THE DIRECTION OF THE MOTOR ROTATION IS CLOCKWISE, WHEN REINSTALLING THE WASH PUMP. IF THE MOTOR IS TURNING COUNTER-CLOCKWISE, EXCHANGE L1 AND L3 WIRES ON MAIN CONTACTOR

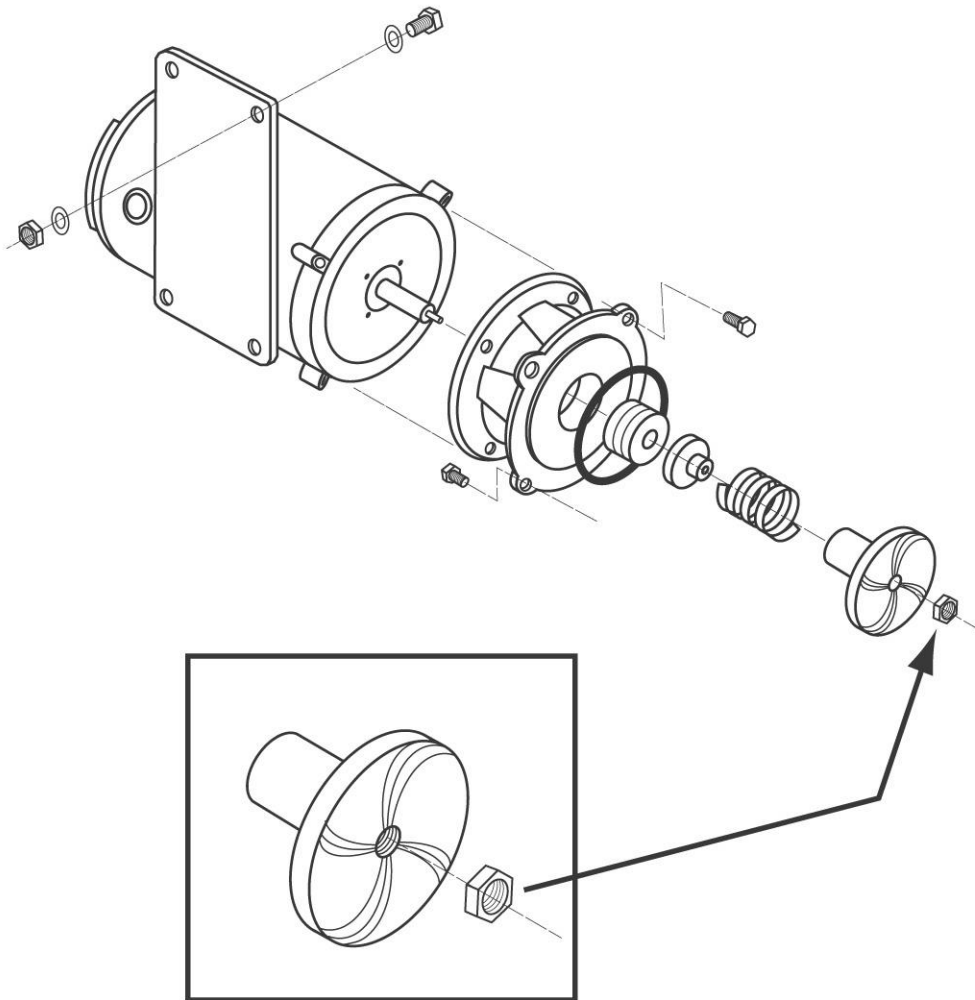

Figure 2.2.6

Note: The **Nylon Lock Nut** indicated by the arrow in **Figure 2.2.6** must be removed before attempting to remove the water pump impeller.

2.2.7. Table Limit Switch Installation

The Model EST-44 is shipped with a Table Limit Switch fully wired and connected in the main control box, ready to be installed on the clean side of the dishtable. The Table Limit Switch **MUST** be installed to prevent dishrack and Conveyor Drive damage.

1. Remove the template that was shipped to hold the table-limit switch assembly together.
2. Remove the activator bar (Figure 2.2.7a).
3. Position the template in the middle of the clean side of the dishtable.
4. Mark the end of the table, where the holes need to be drilled (Figure 2.2.7b).
5. Drill the holes.
6. Attach the Table Limit Switch, using the hardware supplied.
7. Reattach the activator bar removed earlier.
8. Test that it functions properly (Figure 2.2.7c).

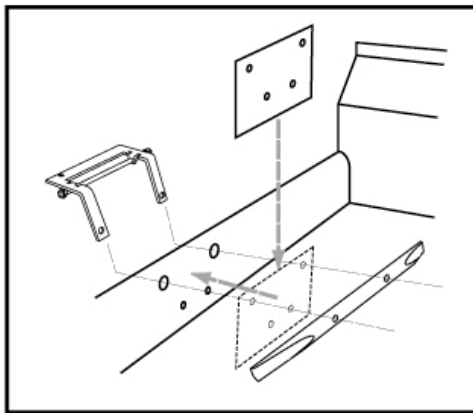

Figure 2.2.7a

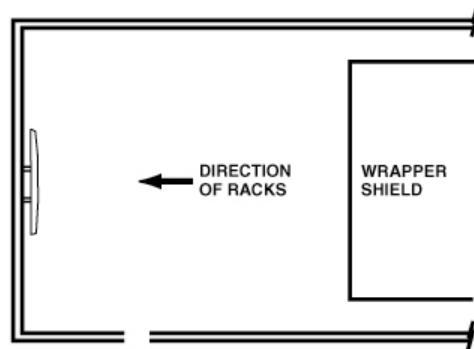

Figure 2.2.7b

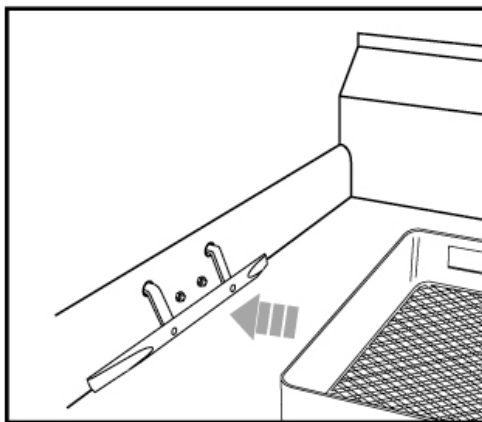
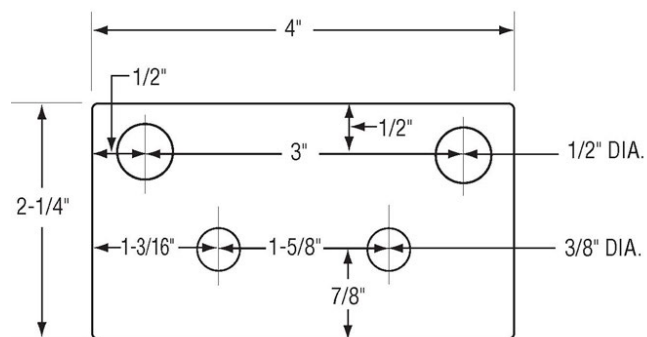

Figure 2.2.7c



Note: This terminal is not actual size, not to be used for installation!

2.2.8. Optional Vent Hood Adapter's Installation

CMA Vent Hood Adapters have been designed and engineered to draw *only* the steam that is released from underneath the curtains at the entrance and exit of the EST-44 conveyor dishwasher. This will allow the dishwasher to retain the heat within the machine, reducing the energy consumption of the dishwasher. To maintain proper CFM's (600), and not evacuate the heat from the dishwasher tanks, CMA Vent Hood Adapters (PN # 13901.82) **MUST be used**.

Note: ON ALL PANT-LEG-STYLE VENT SYSTEMS, BY MODIFYING OR INSTALLING AN UNAUTHORIZED BRAND OF VENT HOOD ADAPTER, IT WILL VOID THE CMA MANUFACTURERS' WARRANTY.

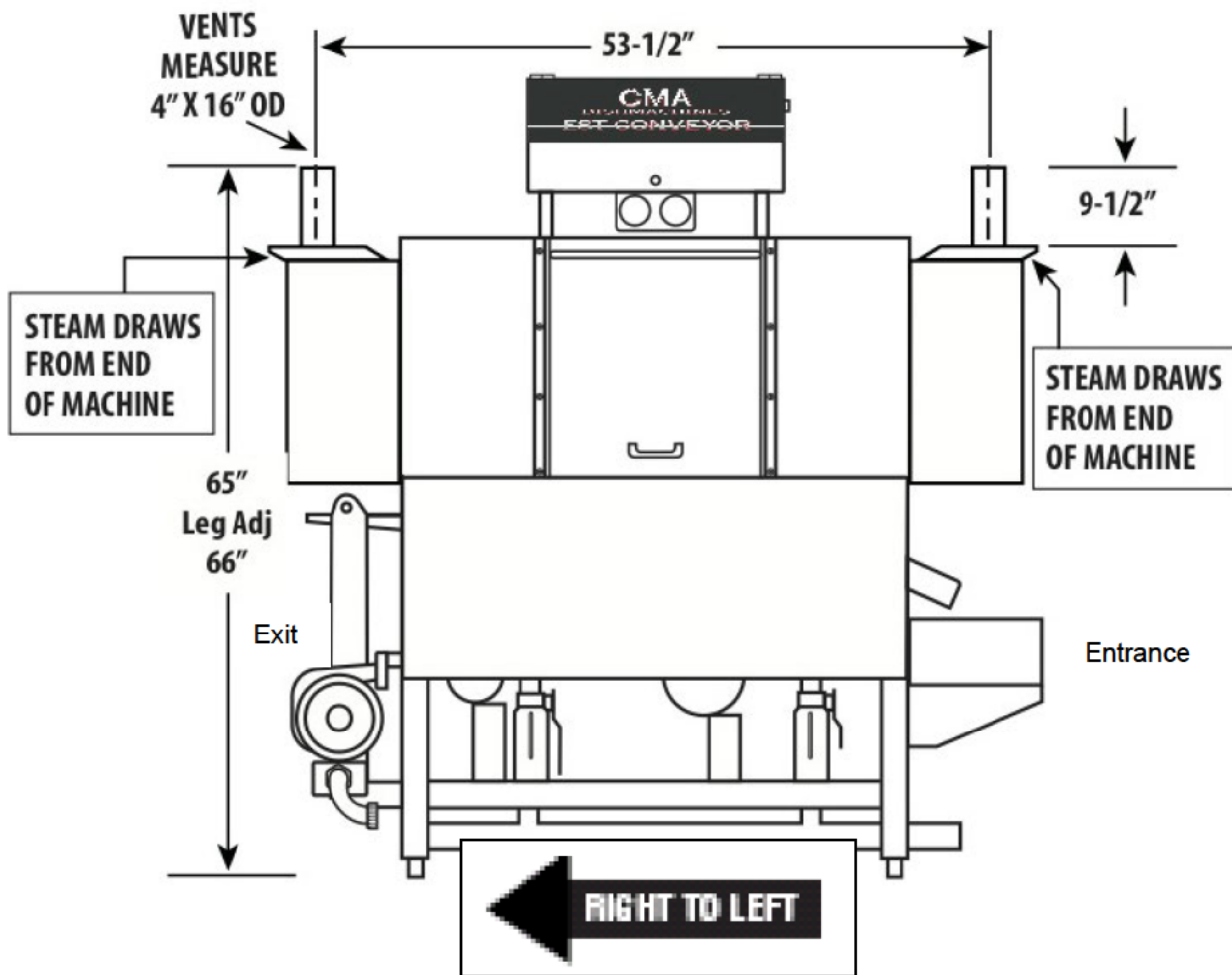

Adjusting the internal baffles of the Vent Hood Adapters:

Once the vent hood adapters have been installed, completely close the internal baffle using two 7/16" wrenches. Run the dishwasher to create heavy steam buildup; start at the exit end of the dishwasher, open the baffle enough to draw the steam into the vent system. Then repeat the same process on the entrance side of the dishwasher.

Note: ONLY ONE OF THE TWO NUTS ON EACH BAFFLE IS USED TO TIGHTEN AND KEEP THE INTERNAL BAFFLE FROM BEING REPOSITIONED.

2.2.9. Chemical Dispenser Connection*

The Model EST-44 will supply both the main power and the signals for the Detergent and Sanitizer/Rinse Aid. Connect the chemical dispenser main power leads, to the supplied power terminals. (See Figure 2.2.9)

Connect the Detergent and Rinse Aid signal wires to the supplied signal terminals (See Figure 2.2.9)

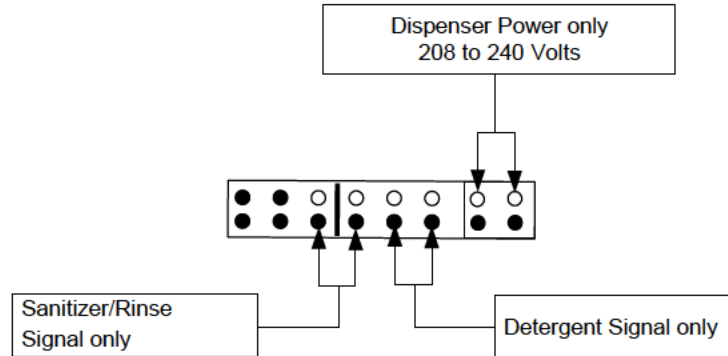

Figure 2.2.9

Note: Sanitizer/Rinse and Detergent signals can draw more than 0.5 Amps.

Note: Use only commercial-grade detergents and rinse aids recommended by your chemical professional. Do not use detergents and rinse aids formulated for residential dishwashers.

Low Temperatures chemical-sanitizing dishmachines must not exceed 6% sodium hypochlorite solution (bleach) as the sanitizing agent. Higher levels may damage stainless or components. Follow the directions precisely that are on the litmus paper vial and test the water on the surface of the bottom of the glasses.

2.2.10. Optional Exhaust Fan Control P/N 13578.00

First, when field-installing the Optional Exhaust Fan Control, locate the detergent signal terminals on the dispenser terminal block; mount the contactor, that was supplied with the kit, securely to the control box; connect the Blue and Yellow wires, also supplied in the kit, to the rinse signal terminals; attach the power for the exhaust fans to the L1 and L2 incoming terminals of the contactor, and the T1 and T2 terminals, to the exhaust fan.

Note: Wires for exhaust fan to be supplied by electrician. (See Figure 2.2.10)

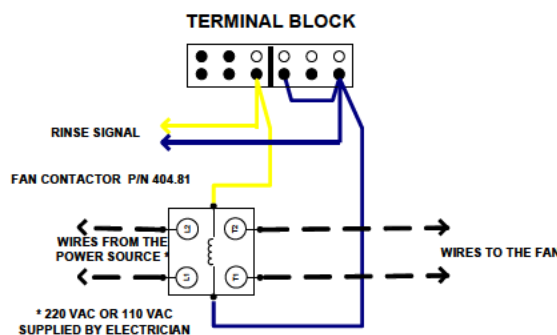

Figure 2.2.10

* Electrical and plumbing connections must be made by a qualified person who will comply with all available Federal, State, and Local Health, Electrical, Plumbing and Safety codes

2.2.11. (Optional) E-Temp Booster Heater*

The Optional E-Temp Booster Heater can only be ordered with a dishwasher, already installed at the factory; it **cannot** be installed in the field. The E-Temp Booster heater will be fully integrated into the EST-44 conveyors' plumbing system. It will require its' own power supply of 208 volts to 240 volts, in single-phase or three-phase. The unit can be specially ordered as a 480-volt unit, in three-phase only; temperature is available in a 40° rise or 70° rise. The E-Temp Booster heater contactor is located in the EST-44 Main Control Box (See item 7, page 6).

Note: E-Temp heater is shipped on the machine empty to prevent freezing. When machine is powered up for the first time, the booster heater must be filled by pressing and holding rinse switch to prevent heater damage.

Note: 70° degree rise E-temp Booster Heater is only available in Three-Phase.



AVAILABLE HOT WATER HEATER TANK CAPACITY	119 GPH 3.9 GAL	(450 LPH) 40
9kW @ 208V, 12kW @ 40°F RISE BOOSTER HEATER (ONE HEATING ELEMENT) OR 12kW @ 480V 40° RISE		
MIN. INCOMING WATER TEMP. RISE	140°F(60°C) 40°F	(22°C)
ELECTRICAL RATING	VOLTS	PHASE
	208	1
	240	1
	208	3
	240	3
	43	43
	50	50
	25	25
	29	29
	15	15

15kW @ 208V, 20kW @ 240V, 70°F RISE BOOSTER HEATER (TWO HEATING ELEMENTS) OR 18kW @ 480V 70° RISE			
MIN. INCOMING WATER TEMP. RISE	110°F 70° F	(43° C) (39° C)	
ELECTRICAL RATING*	VOLTS	PHASE	AMPS
	208	3	42
	240	3	48
	480	3	22
*THE TWO ELEMENTS, 70°F RISE WILL BE AVAILABLE IN 3 PHASE ONLY.			

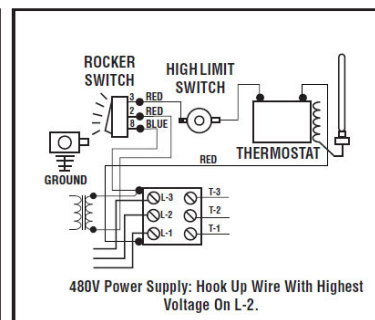
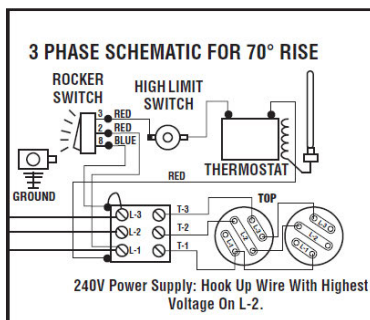
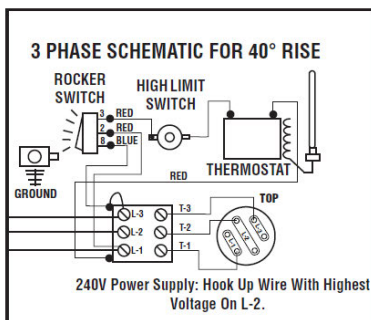

* Electrical and plumbing connections must be made by a qualified person who will comply with all available Federal, State, and Local Health, Electrical, Plumbing and Safety codes

2.3. EST-44 Safety Tips

- DANGER:** Always turn off the **main** circuit breaker at the wall when installing or servicing this dishmachine and/or an E-Temp Booster Heater. Even with the machine's power switch "off", there is a live connection being carried to the switch from the dishmachine contactor.
- CAUTION:** **Do not** get in the path of the Conveyor Rocker Arm or the conveyor's moving bar. **Do not** reach into the rocker arm area without first making sure the dishmachine is turned "off" at the circuit breaker.
- CAUTION:** **Do not** open the front door when the machine is in operation.
- CAUTION:** Avoid spraying water on or around the electrical control box located on the top of the machine. When cleaning, **do not** spray water directly on the motors.
- CAUTION:** When removing the Final Rinse Arms for cleaning, **exercise caution**. The Final Rinse Arms may be filled with chemicals or have additional pressure applied.

3. Operation

3.1. Beginning Operation

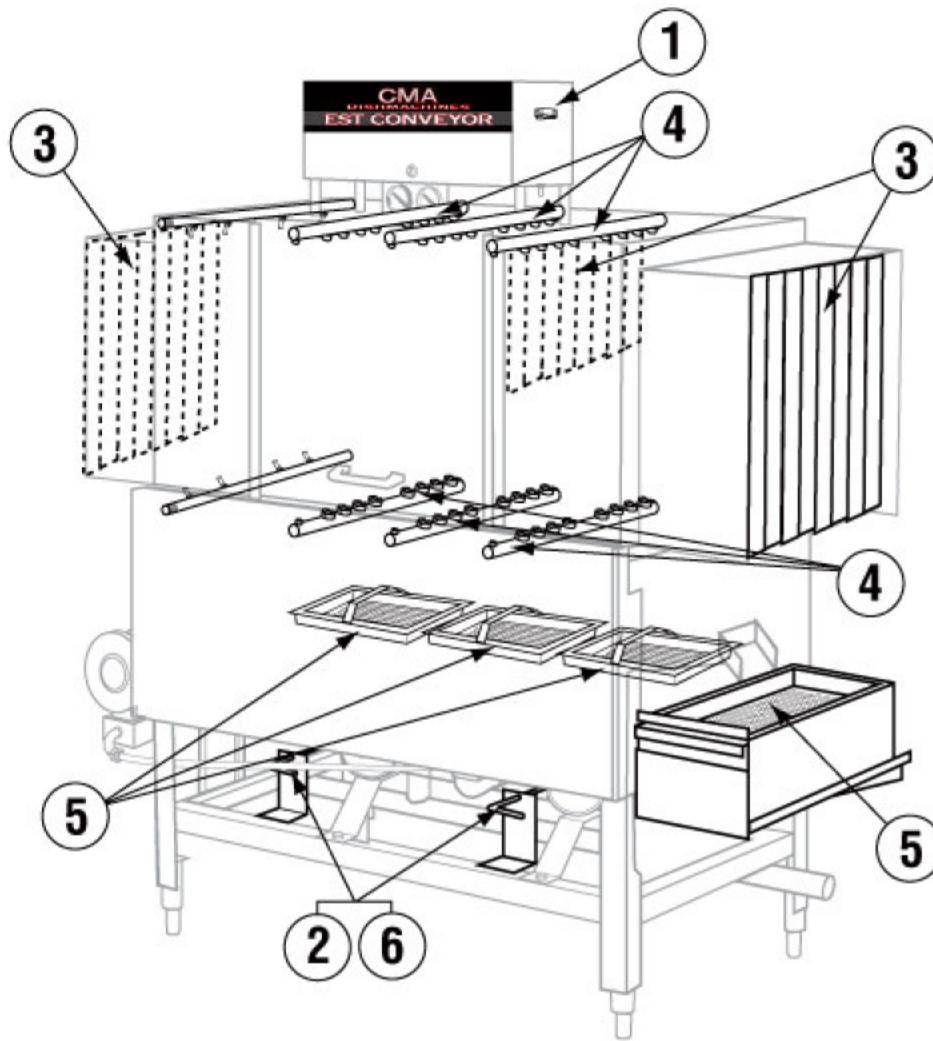
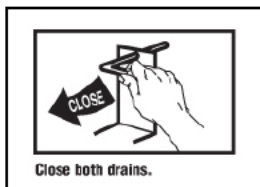
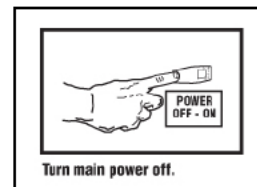

Figure 3.1

Step 1. Close both drains at the bottom of machine (see Fig.3.1 items 2,6 above)



Step 2. Turn on main power and machine will fill with water (see Fig.3.1 item 1 above)



Operation

Step 3. Allow machine to come to temperature

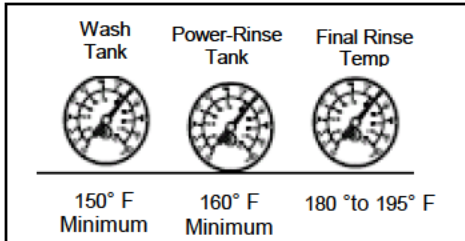

Step 4. Rinse rack thoroughly

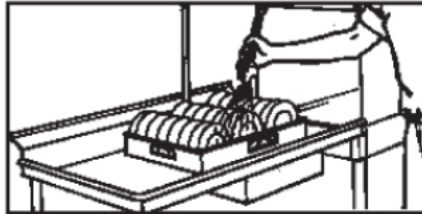

Step 5. Place rack in entrance

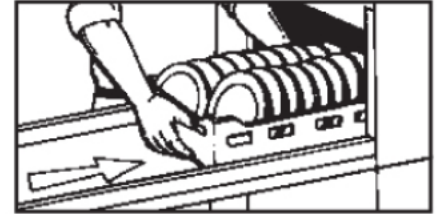

Step 6. Remove dishes from rack

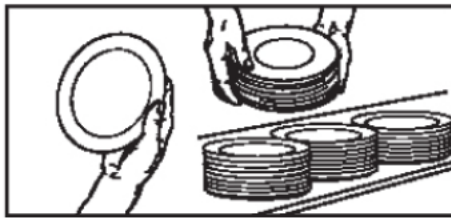

Step 7. Place properly in rack



Step 8. Pre-soak flatware



Step 9. Wash flatware

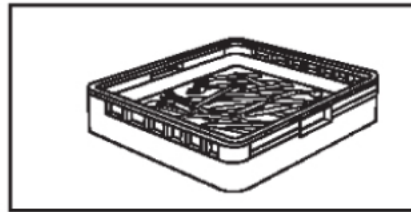

Step 10. Place flatware in containers with handles down; wash a second time

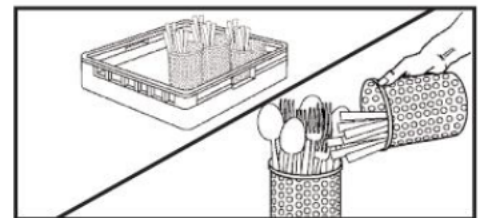

3.2. Cleaning Instructions



Drain dishmachine tanks.

See Fig.3.1, Items 2,6

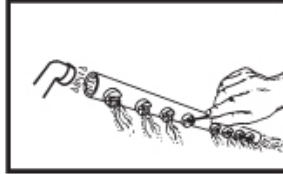

Inspect and clean wash arms.

See Fig.3.1, Items 4



Remove and clean scrap trays and scrap drawer.

See Fig.3.1, Items 5



Remove, clean and re-install the curtains paying attention to location.

See Fig.3.1, Items 3

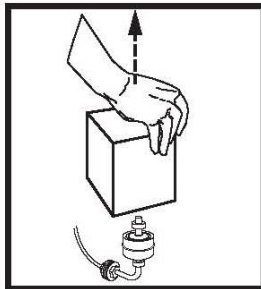

Remove cover, rinse and clean float switch.

3.3. *Regular Service and Maintenance Checklist*

- Check all electrical connections, assuring they are tight and secure.
- Check all Water, Drain, and Plumbing connections for leaks; tighten if needed.
- Check Final Rinse Arms: the Rinse Jet Spray should be straight up & down.
- Check Wash Pump motor rotation, making sure it is turning clockwise.
- Check Dish rack Movement, Conveyor Arm & Bar, and Conveyor Dog Alignment.
- Check Tray Track Guide and Rail & Table Alignment throughout dishwasher.
- Check Timer Dipswitch Setting; only switch 6 should be in “on” position (32 seconds)
- Check Wash-Tank Temperature 150° F Minimum.
- Check Power-Rinse Tank Temperature 160° F Minimum.
- Check Final-Rinse Temperature 180° to 195° F (High-Temp)
(140° F for Low Temp)
- Check Final Rinse Pressure 20 psi, ±5 psi
- Check Table-Limit Switch operation (If not installed, Warranty will be voided)
- Check Vent Hood adapter baffle position to draw steam. (Optional)
(Keep baffles open to a minimum)
- Check and make sure the dishwasher is level.
- Check to make sure all curtains are in place.
- Read all labeling and follow procedures.

Review installation section before beginning the installation of the Model EST-44 Conveyor Dishwasher. All installation procedures and guidelines **MUST BE** followed precisely.

Operation

3.4. Trouble Shooting

PROBLEM	LIKELY CAUSE	SOLUTION
Wash or power rinse motor not running	<i>Bad motor or capacitor</i> <i>Faulty contactor</i>	<i>Replace defective motor or</i> <i>Replace contactor</i>
Machine inoperative	<i>Fuse is burned out</i>	<i>Replace fuse</i>
	<i>Table limit switch</i>	<i>Remove dish rack at switch</i>
	<i>Defective door reed switch</i>	<i>Replace reed switch</i>
	<i>Defective start reed switch</i>	<i>Replace reed switch</i>
	<i>Defective auto/manual switch</i>	<i>Replace switch</i>
	<i>Defective Conveyor Timer</i>	<i>Replace timer</i>
Machine runs continuously	<i>Timer or settings@ 60 Sec</i>	<i>Replace timer or change settings</i>
	<i>Contactor stuck</i>	<i>Replace contactor</i>
Heater (no heat)	<i>Float switch</i>	<i>Check movement-replace it</i>
	<i>Defective thermostat or setting</i>	<i>Replace thermostat or adjust</i>
	<i>Defective heater contactor</i>	<i>Replace heater contactor</i>
	<i>Defective heater</i>	<i>Replace heater</i>
	<i>Wire connections</i>	<i>Check and correct</i>
Racks stuck	<i>Old or broken rack</i>	<i>Replace rack</i>
	<i>Tray track alignment</i>	<i>Adjust track to table properly</i>
Wash & Power rinse tank temperature low	<i>Incoming water supply</i> <i>(Low temp 120°F-Recommend 140°F;</i> <i>High temp 180°F minimum)</i>	<i>Check hot water supply</i>
	<i>Thermostat setting</i>	<i>Adjust thermostat to mach NSF label</i>
	<i>Vent hoods baffle setting</i>	<i>Set CMA Vent hood adapter baffles as instructed on page 13</i>
Low final rinse pressure or no rinse pressure	<i>Plugged rinse jets</i>	<i>Remove and clean</i>
	<i>Pressure regulator out of adjustment</i>	<i>Adjust pressure regulator 20psi to 23psi</i>
	<i>Water sol. valve coil or diaphragm</i>	<i>Replace or clean</i>
	<i>Dirty rinse jets</i>	<i>Remove and clean jets</i>
	<i>Defective rinse reed switch</i>	<i>Replace reed switch</i>
Machine using too much chemical	<i>Quick drain on wash end</i>	<i>Plumb quick drain back into wash tank</i>
	<i>Dispenser or settings</i>	<i>Check dispenser troubleshooting guide</i>
	<i>Rinse pressure</i>	<i>Set 20 psi.</i>
	<i>Soil</i>	<i>Check scrap basket sand float function</i>
Machine loosing water	<i>Quick drain on dirty side table</i>	<i>Check quick drain connections</i>
	<i>Sheet pans</i>	<i>Use CMA sheet pan rack</i>
	<i>Drain valves open</i>	<i>Close completely</i>
Low wash arm pressure	<i>Debris In wash & power rinse arm manifolds</i>	<i>Remove arm, check & clean debris from manifolds</i>
	<i>Clogged jets</i>	<i>Clean jets</i>
	<i>Motors connected wrong</i>	<i>Connect motors to reverse impeller direction</i>

4. EST-44/66 Customer Notice

IMPORTANT NOTICE **INSTALLATION INSTRUCTIONS** **ON NEW STYLE EST-44 and EST-66 Conveyors**

SOIL PURGING SYSTEM: The EST-44 and EST-66 conveyors are multi-tank dishmachines. These conveyors use very little rinse water, less than one gallon per rack of dishes. The rinse water enters the wash and overflows into the pre-wash tank. As water rises in the pre-wash tank it will overflow from the conveyor (carrying soil) to be discharged into the scrap accumulator. *For optimum performance of equipment, it is critical that these installation and set-up instructions be followed precisely.*

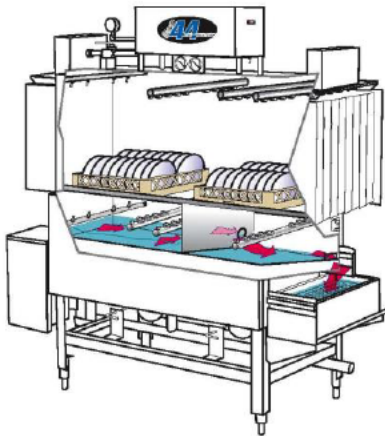

DISHTABLES WITH SCRAP TROUGHS

VERY IMPORTANT: Some dishtables have scrap troughs just prior to entering or exiting conveyor.

Please call "CMA Customer Service" at 800-854-6417 for important installation instruction relating to table scrap troughs or see Customer Notice Section 4 in Installation & Operation Manual.

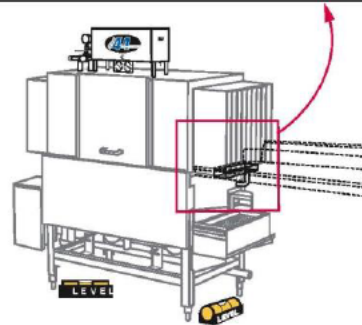
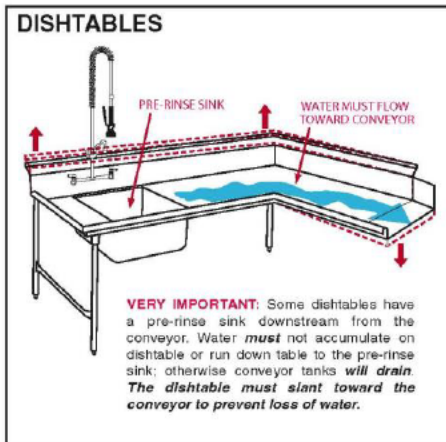

VERY IMPORTANT: These units *must* be installed *level* to the floor, and all the rinse water must be processed through the conveyor and exit the scrap accumulator via the *overflow*. If *any* water is allowed to discharge by other means, the conveyor tanks *will drain*. If the tanks *drain*, there will be *substantial loss* in spray arm pressure, and dishes and utensils will not be cleaned and sanitized properly.

8-19-09

TIPS TO SAVE A SERVICE CHARGE

If the Lessee of this equipment initiates a service call and it is subsequently determined that the problem does not relate to part failure or out of chemicals, there will be a minimum service charge for a service person to respond.

It is recommended that you check the following items before initiating a service call:

- Circuit breaker position. Should be “ON”.
- Clogged drains (at any point in drain line).
- Lack of soft water (check salt level in brine tank).
- Lack of hot water due to valves shut off or incorrect thermostat settings.
- Failure of equipment unrelated to the machine.
- Abuse to equipment or failure to perform minimum cleaning requirements as outlined at time of installation.
 - a. Rinse and wash arm tips clean and free of debris.
 - b. Strainer trays clean and free of debris.
 - c. Water tank drains clean and free of debris.
- Trip switch blocked or held from free movement due to a lodged utensil or dish.
- Lines to chemical buckets found in wrong containers or empty. (Lines to the buckets are color-coded.)

Lessee's service responsibility shall be limited to its initial orientation, delivery of chemicals, adjustment of chemical injection system, and replacement of parts found to be worn or defective.

5. Parts Manual

5.1. Initial Parts Kit

P/N	DESCRIPTION	Qty
00120.02	Bi Metal Thermometer	1
00201.85	Pump Motor, 1HP, 3Ph, 60 Hz, 220V	1
00206.30	Pump Seal Kit	1
00208.21	Slip Joint Nut Friction Ring Plastic	1
00208.40	Slip Joint Nut Gasket	1
00421.83	Power Rocker Switch, Red	1
00562.00	Door Roller Switch	1
00631.05	Ice Cube Relay 220V 12Amp	1
00707.00	½" Water Solenoid Repair Kit JE	1
00738.15	Solenoid Coil JE 220V	1
03202.00	Thermometer (Capillary)	1
03226.00	Pump O-Ring Gasket	1
03623.00	½ Vac Breaker Repair Kit Watts	1
13003.17	Contactora, 60-Amp	1
13003.50	Contactora, 30-Amp	1
13003.70	Toggle Switch SPDT 20AMP	1
13012.26	Motor Contactora, 220V	1
13013.45	Conveyor Motor Overload Relay	1
13014.40	Power Rinse Overload Relay	1
13403.26	Fuse, 3-Amp/250V Slow Blow	2
13408.64	Table Limit Switch Bracket Spring	1
13415.47	Heater 3kW (GL-C & EST-66)	1
13417.92	Heater Thermostat	1
13418.60	Dip Switch Timer 230V	1
13422.83	Immersion Heater, 3Ph/1Ph, 208, 13kW	1
13427.10	Table Limit Switch	1
13465.00	Dual Float Switch, SS	1
13503.60	Power Rinse Pump - 1ph 208-240v 60HZ	1
13503.06	EST-44 Gear Motor Assy	1
13507.65	Cam Bearing Assy (New Dec 2007)	1
13508.70	Heavy Duty Clutch Spring	1

Parts Manual

5.2. Exploded View Drawings

5.2.1. Cabinet Assembly

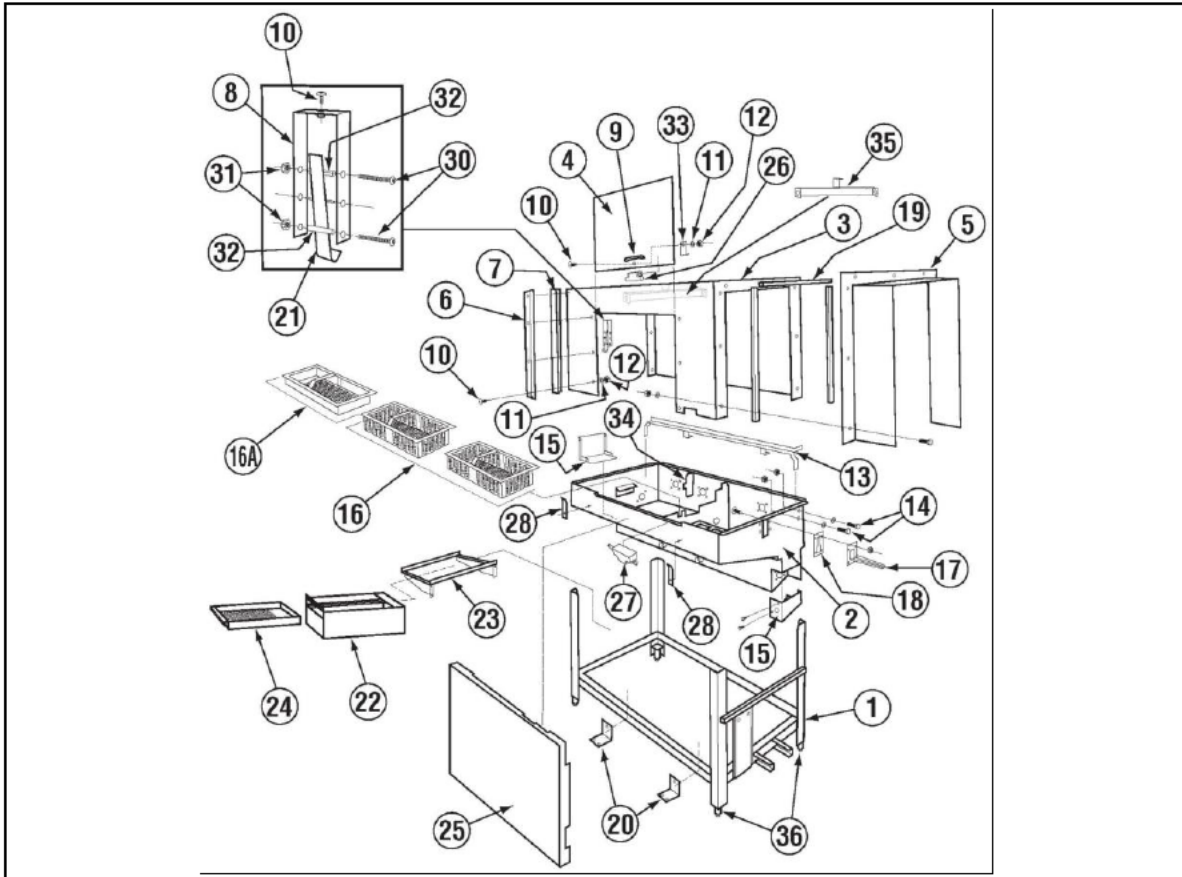

ITEM NO.	NO. REQ'D	P/N	DESCRIPTION
1	1	13939.22	Universal CMA-44/EST Stand
2	1	13969.36	EST-44 Pan L-R
		13969.26	EST-44 Pan R-L
3	1	13939.09	EST-44 Wrapper L-R
		13939.19	EST-44 Wrapper R/L
4	1	01506.54	EST-44 Door L-R
		01506.52	EST-44 Door R-L
5	2	13901.10	Wrapper Shield
6	2	01554.30	Door Guide
7	2	00636.10	Door Guide Plastic
8	1	13915.60	Door Latch Bracket Single Piece
9	1	00535.30	Door Handle
10	28	00905.00	1/4-20 x 1/2" Trusshead Bolt
11	61	00924.00	1/4" Washer, SS
12	53	00912.00	1/4-20 Nylon Lock Nut
13	2	13906.17	EST-44 Tray Track RH
		13906.19	EST-44 Tray Track LH
14	8	00914.10	1/4-20 x 5/8" Hex Head Bolt
		13939.50	EST-44 Heater Cover
15	2	13939.50	EST-44 Heater Cover
16	2	13942.30	Strainer Basket EST44 (3" deep)
16A	1	13942.00	Strainer Basket, Wash/Rinse EST44/66

ITEM NO.	NO. REQ'D	P/N	DESCRIPTION
17	1	13913.10	Drip Chute
18	1	13542.10	Drip Chute Gasket
19	4	03705.00	Foam Tape
20	2	13010.06	Drain Valve Handle Support
21	1	13701.00	Door Latch
22	1	01579.10	Scrap Trap Body (Univ)
23	1	17579.20	EST Scrap Trap Holder
24	1	01579.20	Scrap Trap Drawer (Univ)
25	1	13912.14	CMA 44 Splash Shield (09)
26	1	00556.60	Reed Switch Magnet -ISI
27	1	00556.10	Reed Switch-ISI
28	2	13912.81	Splash Shield Clip
29	1	01577.36	Scrap Trap Cover SS (Hi Temp)
30	1	00960.00	8-32x1-1/2" Panhead Screw
31	1	00927.00	8-32 Nylon Lock Nut
32	2	13915.30	Door Latch Bracket Spacer
33	1	13701.30	Door Stop Bracket
34	2	01505.15	EST-44 Support Bracket Tray Track
35	1	13949.10	EST-44/66 Wrapper Brace
36	4	01310.30	Adjustable Foot w/ SS Toe

Parts Manual

5.2.2. Control Box Assembly (3 Phase)

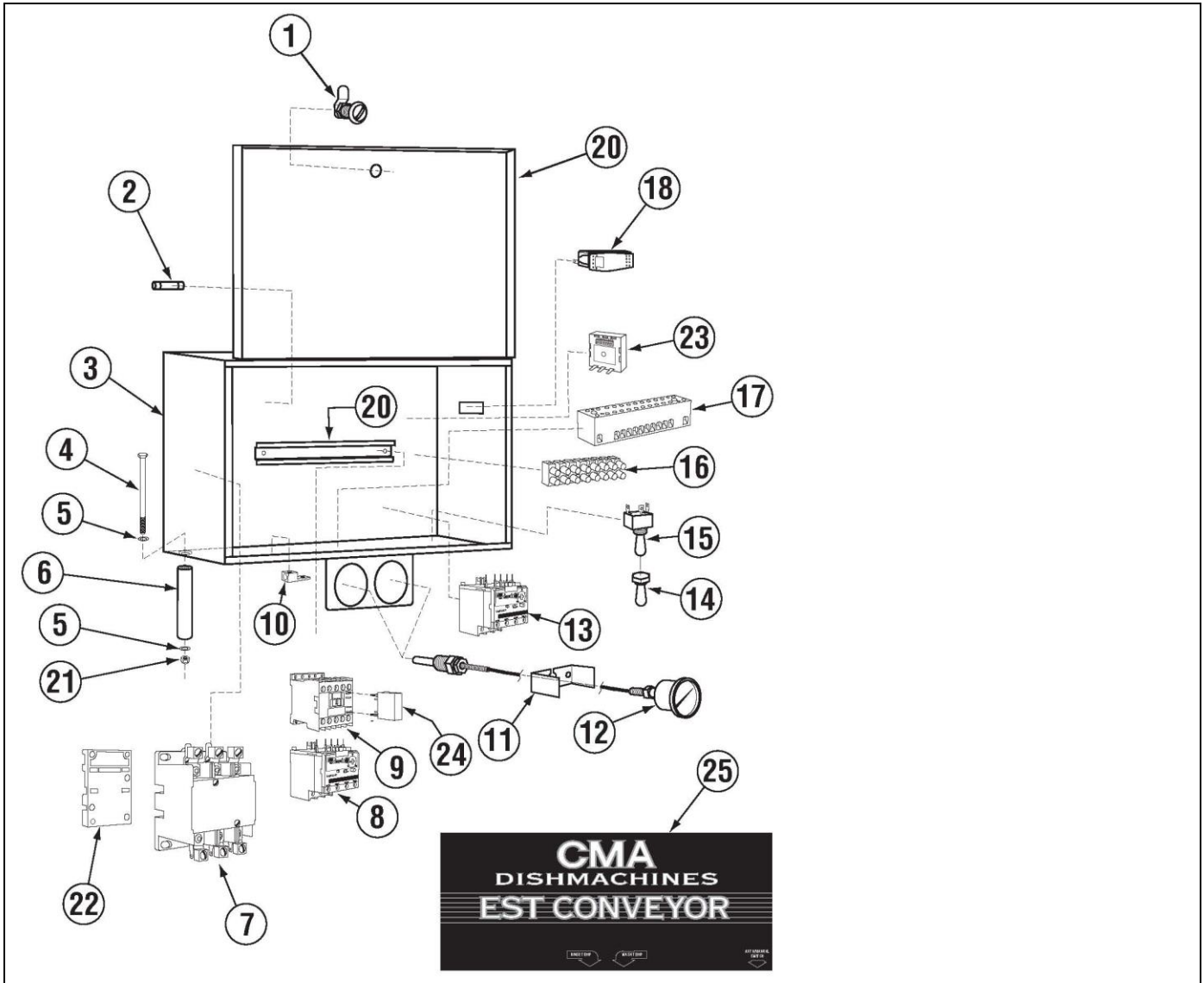

ITEM NO.	NO. REQ'D	P/N	DESCRIPTION
1	1	00449.50	Lock, Keyless
2	2	13403.26	Fuse, 3-Amp/250V Slow Blow
3	1	13941.12	EST-44 Control Box Body
4	4	00909.00	¼"-20x3 ¼" SS Hexhead Bolt
5	8	00924.00	¼" SS Washer
6	4	13941.20	EST-44 Control Box Legs
7	2	13003.17	Contactor 60 Amp 3 Pole
8	1	13013.45	Overload Relay 0.4 to 0.63 Conveyor
9	4	13012.26	Motor Contactor, 220V
10	1	13426.50	Ground Block
11	2	03202.08	Thermometer Bracket
12	2	03202.00	Thermometer
13	1	13014.40	Overload Relay 1.6 to 2.5 Power Rinse

ITEM NO.	NO. REQ'D	P/N	DESCRIPTION
14	1	00470.10	Toggle Switch Rubber Boot
15	1	13003.70	Toggle Switch SPDT 20AMP
16	1	00454.20	8-Pole Terminal Block
17	1	15520.00	Power Block 12-Position
18	1	00421.83	Power Rocker Switch, Red
19	1	13003.60	Starter DIN Rail
20	1	13941.22	EST-44 Control box lid
21	4	00912.00	¼"-20 Nylon Lock Nut
22	2	13003.62	Din Rail Mounting Bracket
23	1	13418.60	Dip Switch Timer 230 V
24	3	13012.29	Surge Absorber
25	1	06232.20	EST Conveyor Label Full Size label

Parts Manual

5.2.1. Control Box Assembly (1 Phase)

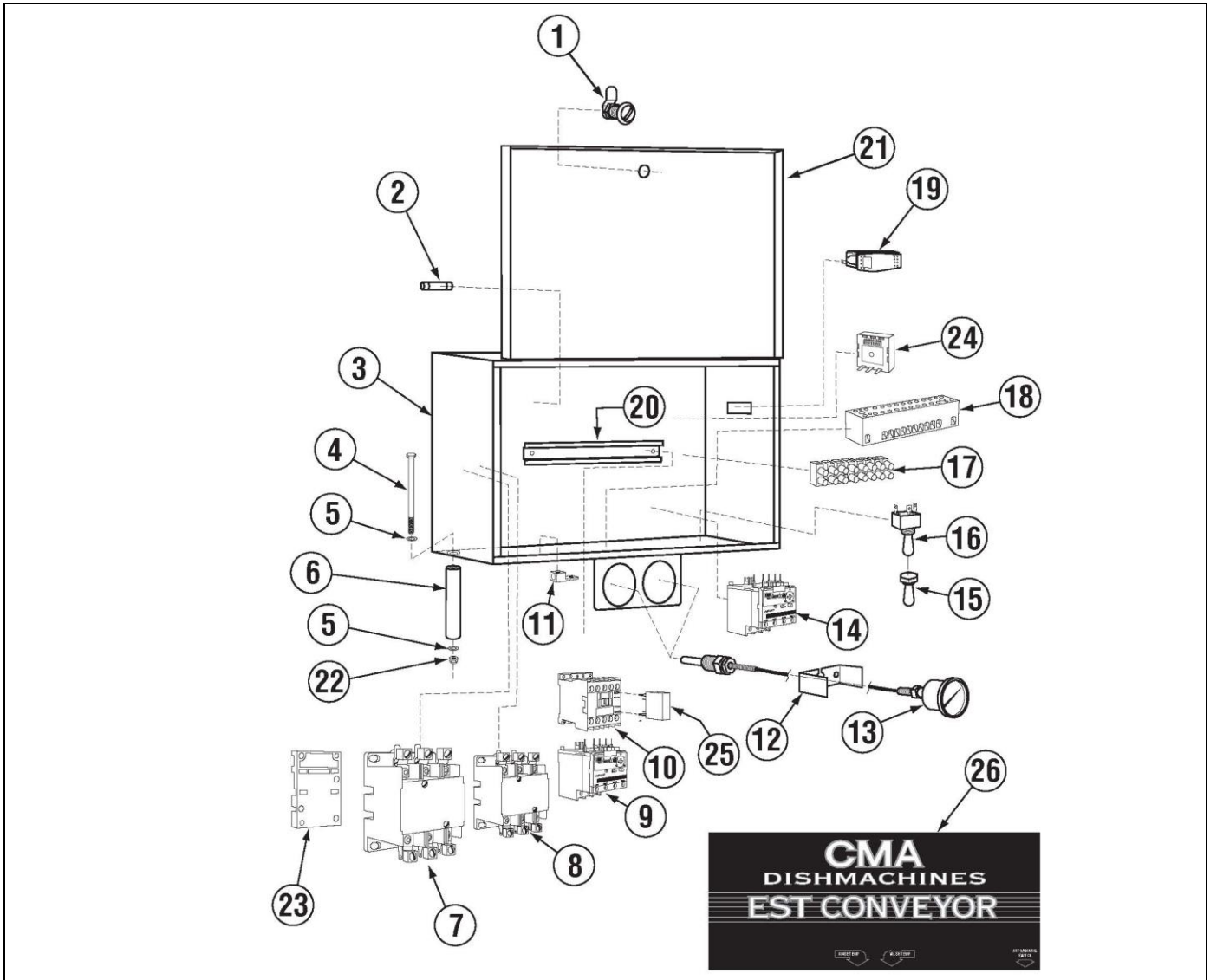

ITEM NO.	NO. REQ'D	P/N	DESCRIPTION
1	1	00449.50	Lock, Keyless
2	2	13403.26	Fuse, 3-Amp/250V Slow Blow
3	1	13941.12	EST-44 Control Box Body
4	4	00909.00	¼-20x3 ¼ SS Hexhead Bolt
5	8	00924.00	¼ SS Washer
6	4	13941.20	EST-44 Control Box Legs
7	1	13003.18	Contacteur 75 Amp 3 Pole
8	1	13003.17	Contacteur 60 Amp 3 Pole
9	1	13014.48	Overload Relay 0.63 to 1.0 Conveyor
10	4	13012.26	Motor Contactor, 220V
11	1	13426.50	Ground Block
12	2	03202.08	Thermometer Bracket
13	2	03202.00	Thermometer

ITEM NO.	NO. REQ'D	P/N	DESCRIPTION
14	1	13014.40	Overload Relay 1.6 to 2.5 Power Rinse
15	1	00470.10	Toggle Switch Rubber Boot
16	1	13003.70	Toggle Switch SPDT 20AMP
17	1	00454.20	8-Pole Terminal Block
18	1	15520.00	Power Block 12-Position
19	1	00421.83	Power Rocker Switch, Red
20	1	13003.60	Starter DIN Rail
21	1	13941.22	EST-44 Control box lid
22	4	00912.00	¼-20 Nylon Lock Nut
23	2	13003.62	Din Rail Mounting Bracket
24	1	13418.60	Dip Switch Timer 230 V
25	3	13012.29	Surge Absorber
26	1	06232.20	EST Conveyor Label Full Size label

Parts Manual

5.2.2. 480V Control Box Assembly (480V machines only)

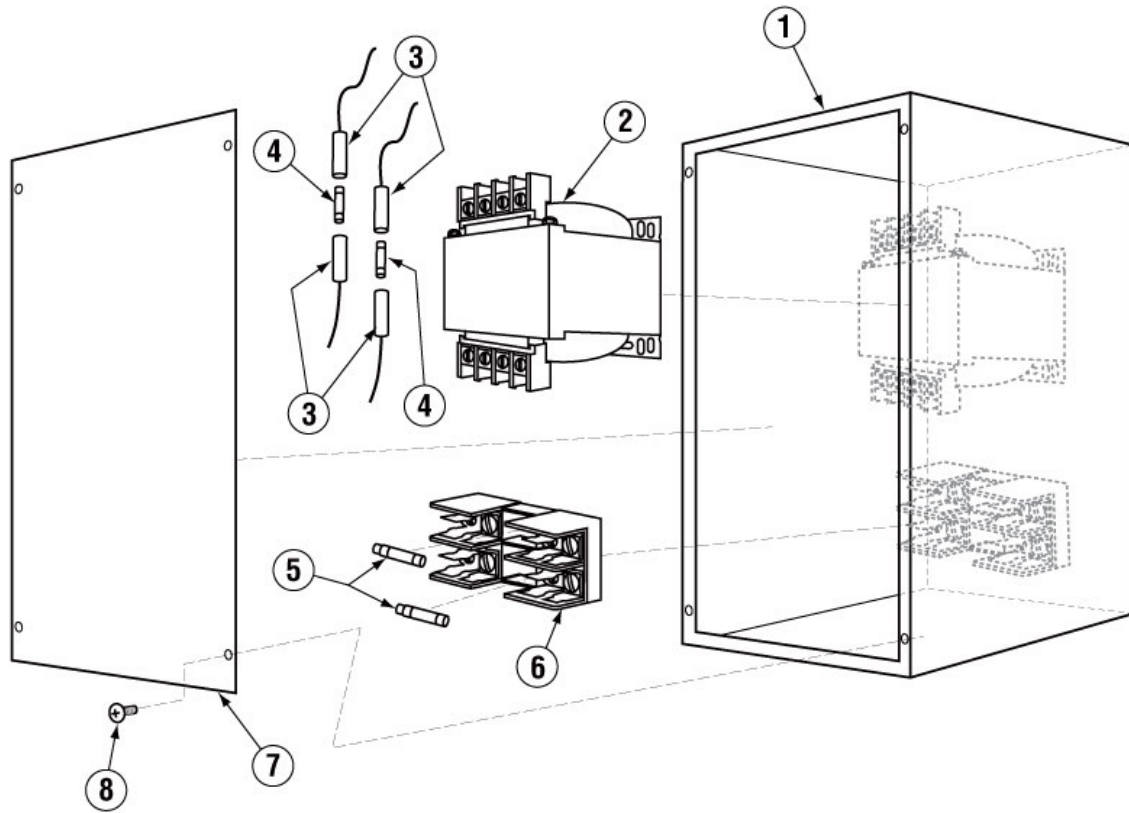

ITEM NO.	NO. REQ'D	P/N	DESCRIPTION
1	1	13905.13	Transformer Box
2	1	13423.82	Transformer 480V - 240V
3	2	13403.21	Fuse Holder - Inline
4	2	13403.40	Fuse 1.25 Amp 230V Slow Blow
5	2	13402.10	Fuse 1.50 Amp 600V Slow Blow
6	1	13420.10	Fuse Clip 2-Poll, Pressure Plate
7	1	13905.23	Transformer Box Lid
8	4	00940.50	10-32 X 3/8 Truss Head Screw

Parts Manual

5.2.3. Curtain and Optional Vent System

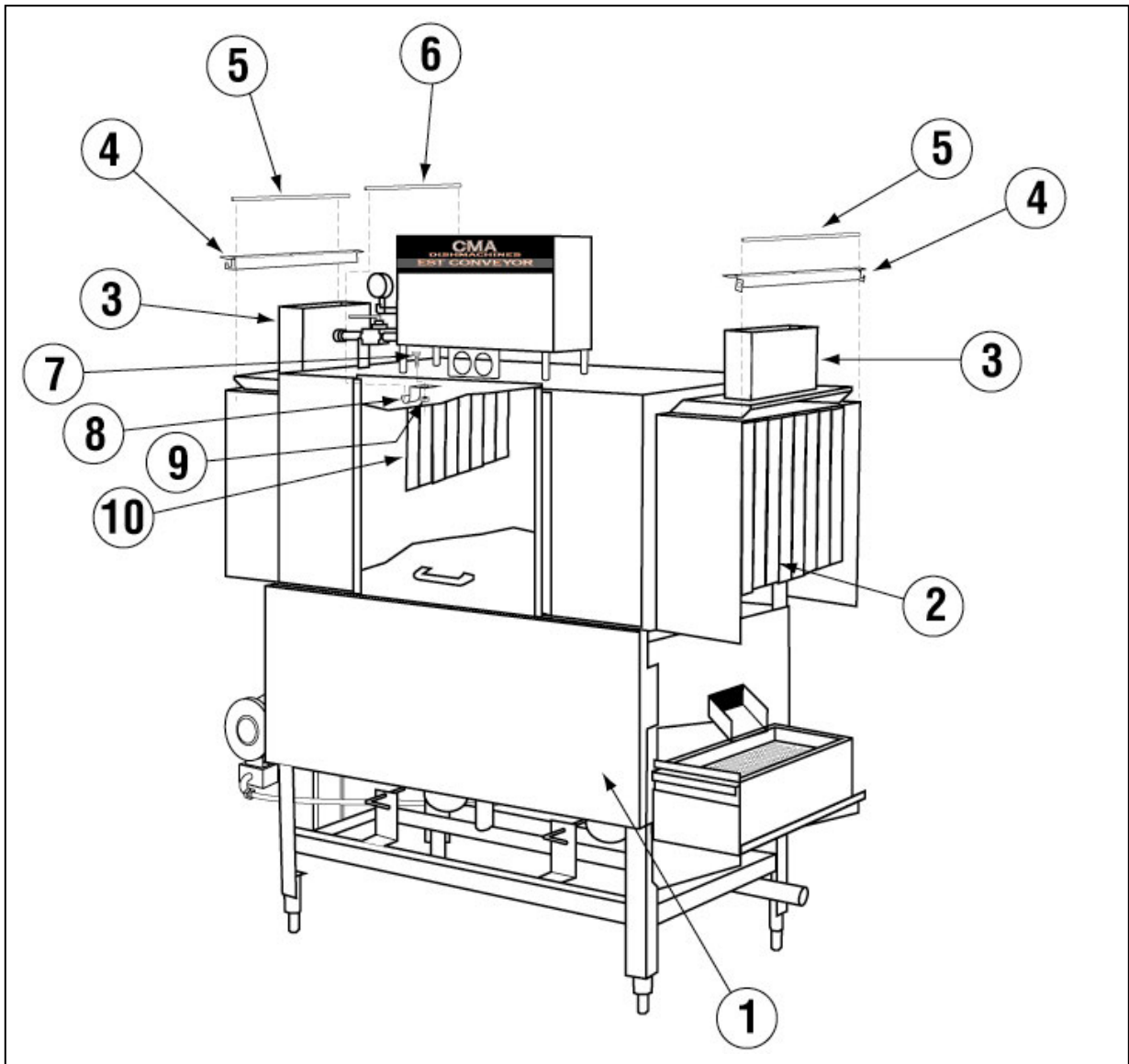

ITEM NO.	NO. REQ'D	P/N	DESCRIPTION
1	1	13912.14	CMA 44 Splash Shield (09)
2	2	13702.25	Curtain CMA-44(20-5/8" x 15")
3	2	13901.82	Hood Adapter EST-44 (2 pc set)
4	2	13901.30	Outer Wrap Shield Curtain Support
5	2	13705.00	Curtain Rod Short

ITEM NO.	NO. REQ'D	P/N	DESCRIPTION
6	2	13705.10	Curtain Rod Long
7	4	00914.10	1/4-20 X 5/8 Hexhead Bolt
8	2	13901.12	CMA 44 Wash Curtain Support ('07)
9	4	00912.00	1/4-20 Nylon Lock Nut
10	1	13702.35	Curtain CMA-44 (24 5/8" x 11-1/2")

Parts Manual

5.2.4. Old Wash Temperature Control System (Square Flange)

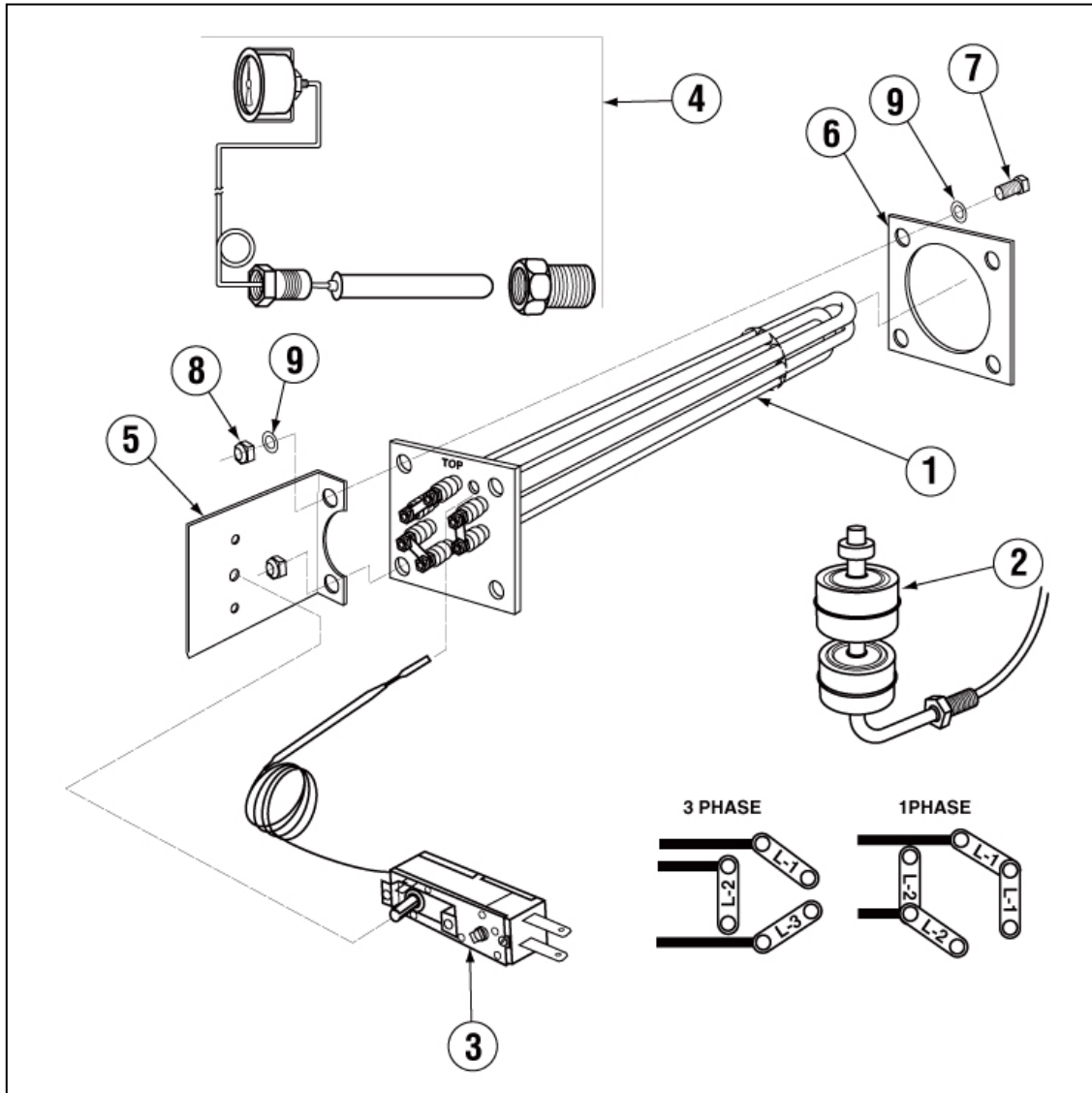

ITEM NO.	NO. REQ'D	P/N	DESCRIPTION
1	1	13417.75	Immersion Heater 3hp/1PH 380V 10kW
	1	13417.80	Immersion Heater 3Ph/1PH 240V 10kW
2	1	13465.00	EST-44/66 Dual Float Switch
3	1	13417.92	Thermostat (EGO)
4	1	03202.00	Thermometer

ITEM NO.	NO. REQ'D	P/N	DESCRIPTION
5	1	13416.10	Thermostat Bracket
6	1	13417.45	Heater Gasket
7	4	00901.00	5/16 – 18 x 1" Hexhead Bolt
8	4	13805.00	5/16 – 18 Nylon Nut
9	8	00926.00	5/16" SS washer

Parts Manual

5.2.5. New Wash Temperature Control System (Triangular Flange)

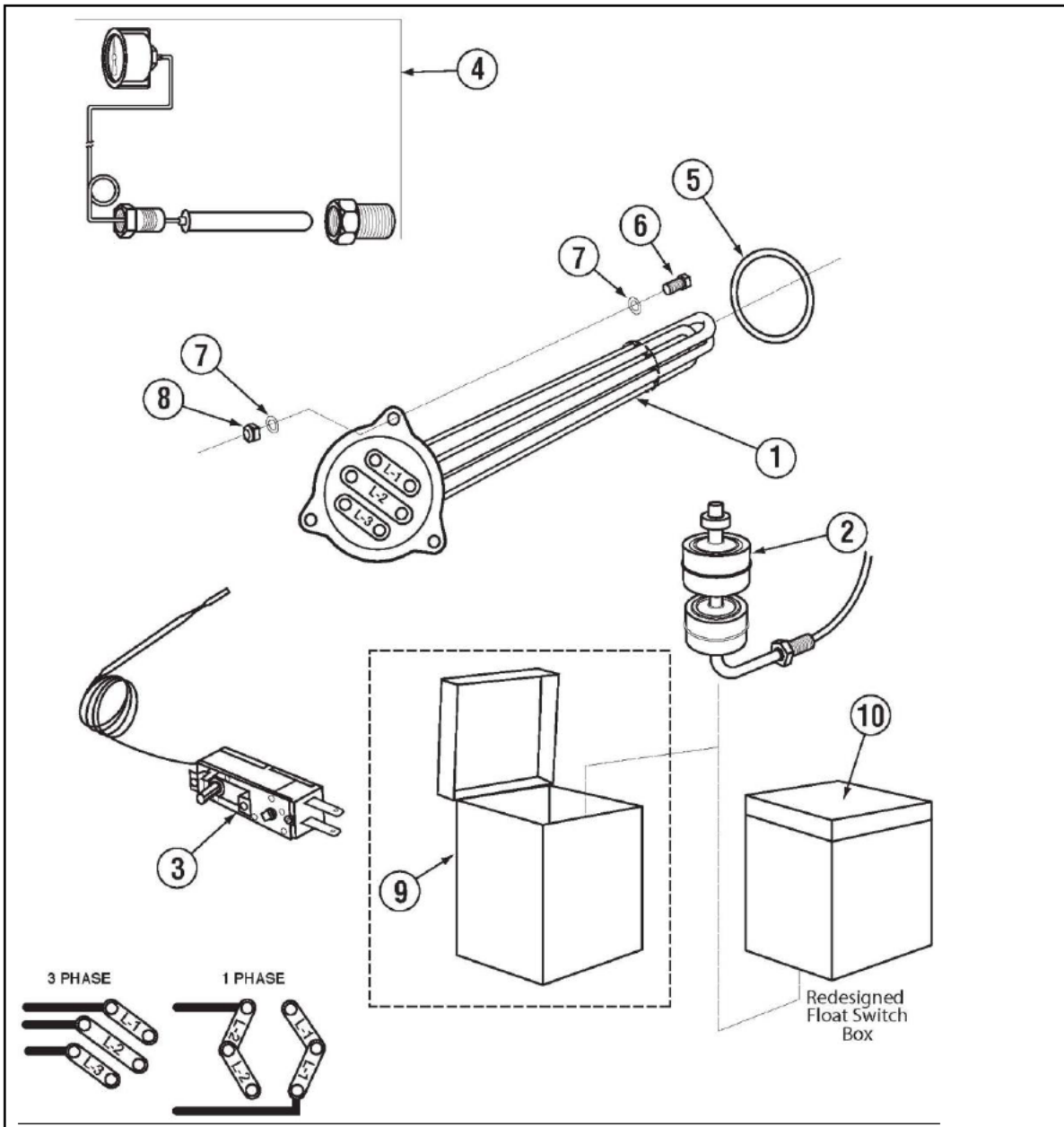

ITEM NO.	NO. REQ'D	P/N	DESCRIPTION
1	1	13422.75	480V 12KW Triangular Immersion Htr.
	1	13422.80	208V 10KW Triangular Immersion Htr.*
	1	13422.83	208V 13KW Triangular Immersion Htr.**
2	1	13465.00	EST-44/66 Dual Float Switch
3	1	13417.92	Thermostat (EGO)
4	1	03202.00	Thermometer

ITEM NO.	NO. REQ'D	P/N	DESCRIPTION
5	1	15518.11	Heater Gasket
6	4	00914.00	1/4-20 X 3/4 Hexhead Bolt
7	4	00914.00	1/4-20 X 3/4 Hexhead Bolt
8	8	00924.00	1/4" SS washer
9	1	13943.00	Float Switch Box
10	1	13946.00	Float Switch Box (comes with # 13946.50)

* For single phase machines ** For three phase machines.

5.2.6. Rinse Temperature Control System

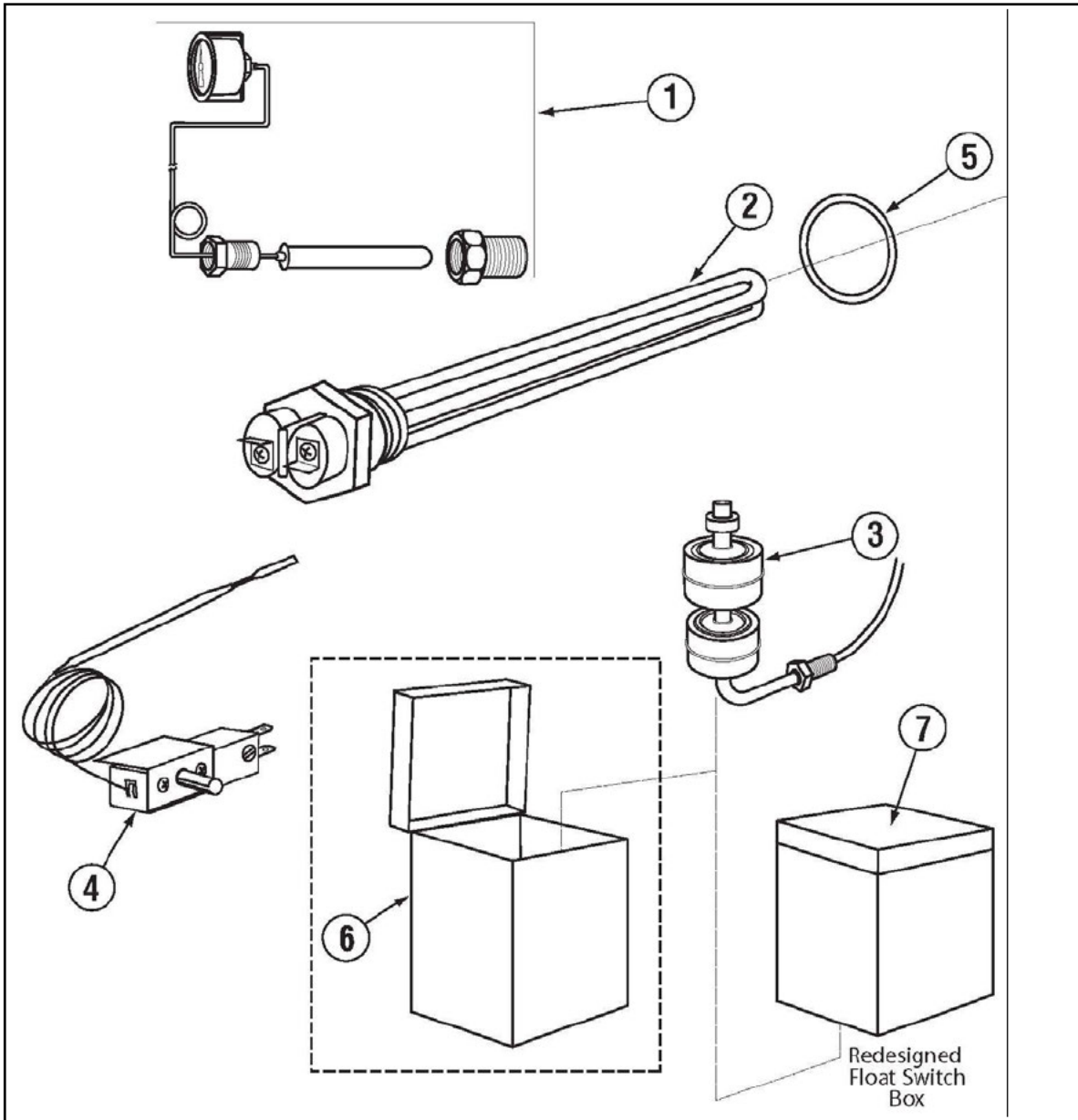

ITEM NO.	NO. REQ'D	P/N	DESCRIPTION
1	1	03202.00	Thermometer
2	1	13415.47 13955.00	Heater 3kW (GL-C & EST-66) Immersion Heater 3kW 480V
3	1	13465.00	Float Switch
4	1	13417.92	EST-66 Heater Thermostat (EGO)
5	1	00703.00	O-Ring Gasket
6	1	13943.00	Float Switch Box
7	1	13946.00	Float Switch Box (comes with # 13946.50)

Parts Manual

5.2.7. Wash Pump Assembly (3 Phase)

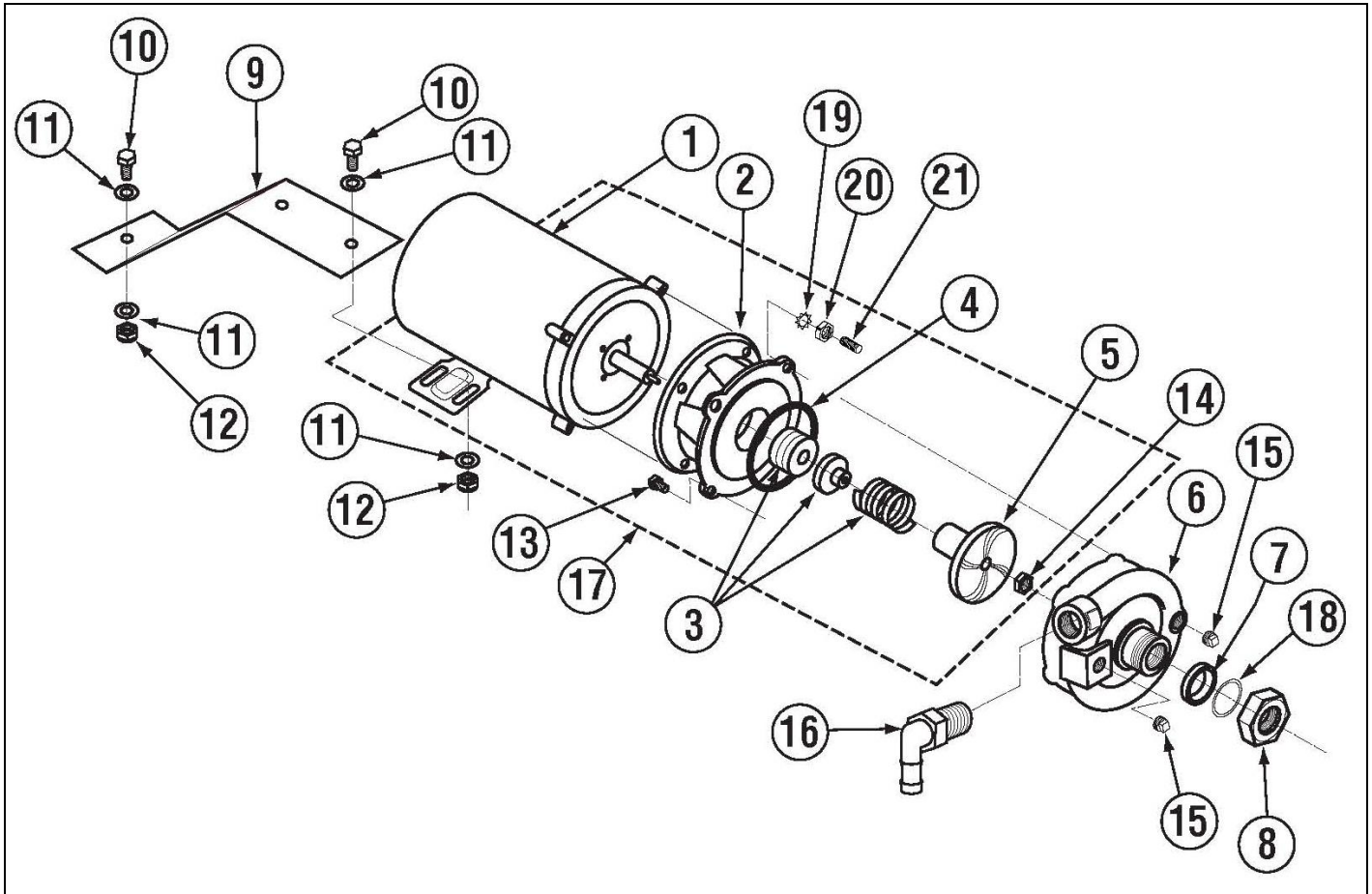

ITEM NO.	NO. REQ'D	P/N	DESCRIPTION
1	1	00201.85	Pump Motor, 1HP, 60 Hz, 220/460V
2	1	04207.10	Pump Base Mount
3	1	00206.30	Pump Seal Kit New
4	1	03226.00	Pump O-Ring Gasket
5	1	03222.10	Impeller (Open) SS
6	1	04207.20	Pump Cover
7	1	00208.40	Slip Joint Nut Gasket
8	1	00207.00	Compression Nut, 2.5"
9	1	13916.40	Motor Support Bracket
10	3	00906.00	1/4-20 x 1/2" Hex Bolt
11	6	00922.00	1/4" Lock Star Washer

ITEM NO.	NO. REQ'D	P/N	DESCRIPTION
12	3	00912.00	1/4-20 Nylon Lock Nut
13	8	00921.00	3/8-16 x 3/4" SS Hex Head Bolt
14	1	13829.00	7/16-20 Thin Nylon Lock Nut
15	2	00238.00	3/8" Male Plug
16	1	04604.00	^35 Deg Elbow MIP X Barb SS
17	1	00200.85	Pump Assembly, 1HP, 3Ph, 220V, 60 Hz*
18	1	00208.21	Slip Joint Nut Friction Ring
19	2	03807.50	3/8 External Lock Star Washer
20	2	03810.00	3/8-16 Thin Nut
21	2	00975.00	3/8"-16 x 1 1/2" SS Stud

*Includes Items 1, 2, 3, 4, 5 and 14.

Parts Manual

5.2.8. Wash Pump Assembly (1 Phase)

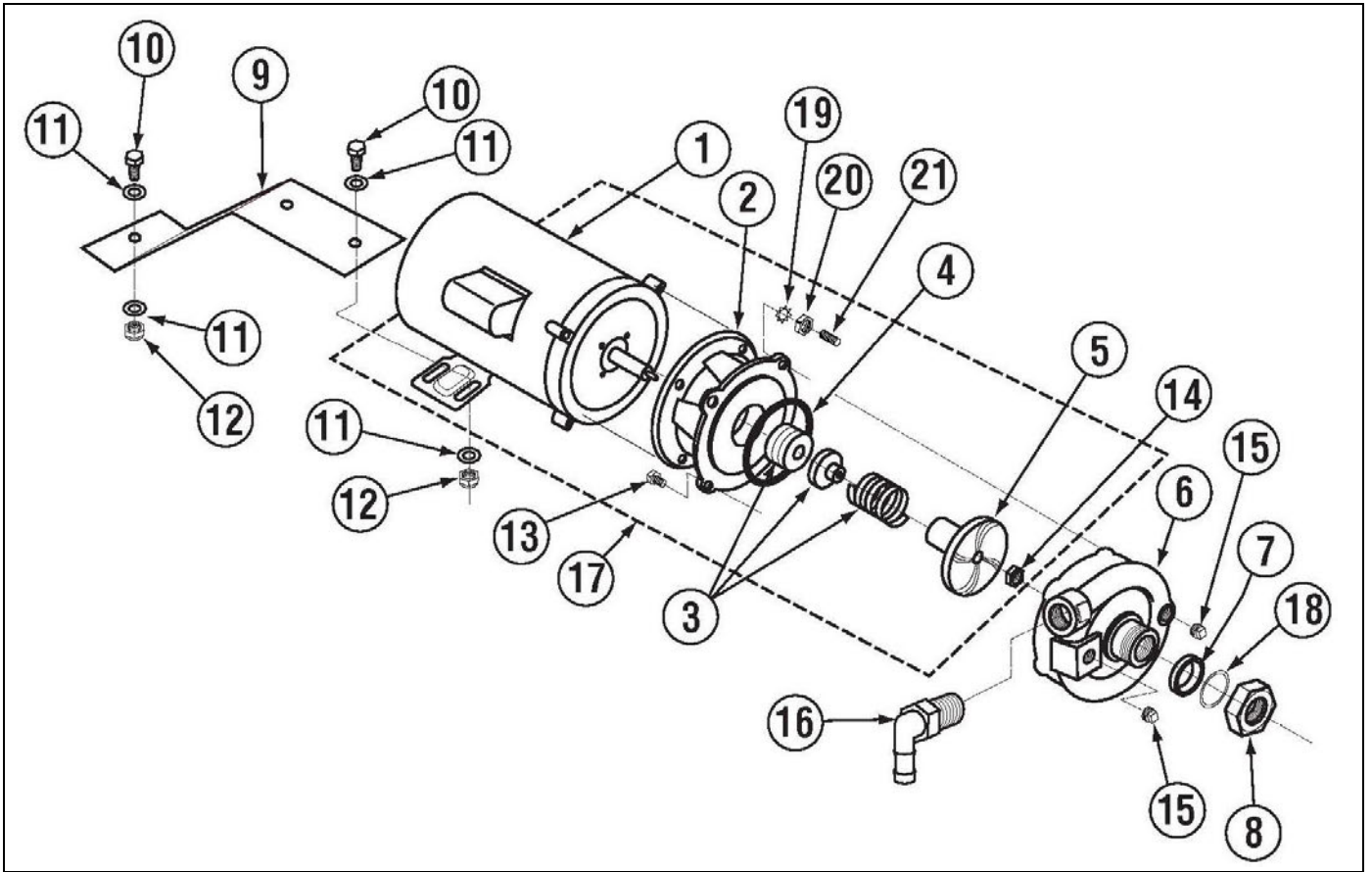

ITEM NO.	NO. REQ'D	P/N	DESCRIPTION
1	1	00201.00	Pump Motor 1 Hp,115/220V ,60Hz
2	1	04207.10	Pump Base Mount
3	1	00206.30	Pump Seal Kit New
4	1	03226.00	Pump O-Ring Gasket
5	1	03222.10	Impeller (Open) SS
6	1	04207.20	Pump Cover
7	1	00208.40	Slip Joint Nut Gasket
8	1	00207.00	Compression Nut, 2.5"
9	1	13916.40	Motor Support Bracket
10	3	00906.00	1/4-20 x 1/2" Hex Bolt
11	6	00922.00	1/4" Lock Star Washer

ITEM NO.	NO. REQ'D	P/N	DESCRIPTION
12	3	00912.00	1/4-20 Nylon Lock Nut
13	8	00921.00	3/8-16 x 3/4" SS Hex Head Bolt
14	1	13829.00	7/16-20 Thin Nylon Lock Nut
15	2	00238.00	3/8" Male Plug
16	1	04604.00	^35 Deg Elbow MIP X Barb SS
17	1	00201.10	Pump Assy 115/220V ,60Hz*
18	1	00208.21	Slip Joint Nut Friction Ring
19	2	03807.50	3/8 External Lock Star Washer
20	2	03810.00	3/8-16 Thin Nut
21	2	00975.00	3/8"-16 x 1 1/2" SS Stud

*Includes Items 1, 2, 3, 4, 5 and 14.

Parts Manual

5.2.9. Power Rinse Pump Assembly

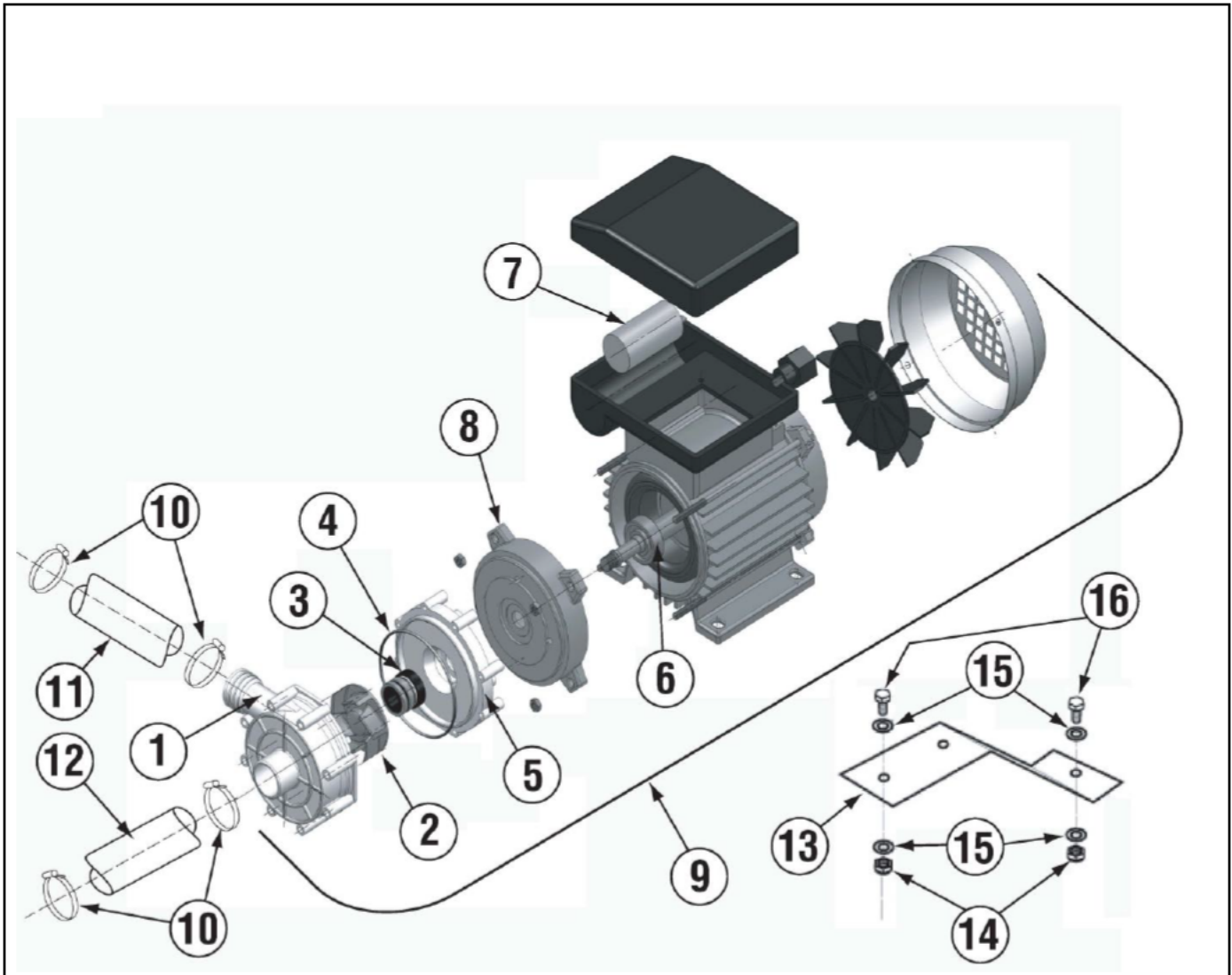

ITEM NO.	NO. REQ'D	P/N	DESCRIPTION
1	1	13503.70	Pump Head
2	1	13503.71	Impeller
3	1	13503.72	Seal Kit
4	1	13503.73	Pump O-Ring
5	1	13503.74	Back Plate
6	1	13503.75	Motor
7	1	13503.76	Capacitor
8	1	13503.77	Cover

ITEM NO.	NO. REQ'D	P/N	DESCRIPTION
9	1	13503.60 13503.80	Olympia Pump - 1ph 208-240v 60HZ Olympia Pump - 3ph 480v, 60HZ
10	4	03101.00	Hose Clamp # 16 1"
11	1	03108.66	Transfer Hose 1" - 35"
12	1	03108.65	Transfer Hose 1" - 3-1/2"
13	1	13916.45	EST-44 Final Rinse Motor Bracket
14	3	00906.00	1/4-20x1/2" Hex Bolt
15	6	00922.00	1/4-20 Lock Star Washer
16	3	00912.00	1/4-20 Nylon Nut

Parts Manual

5.2.10. Drain System Assembly

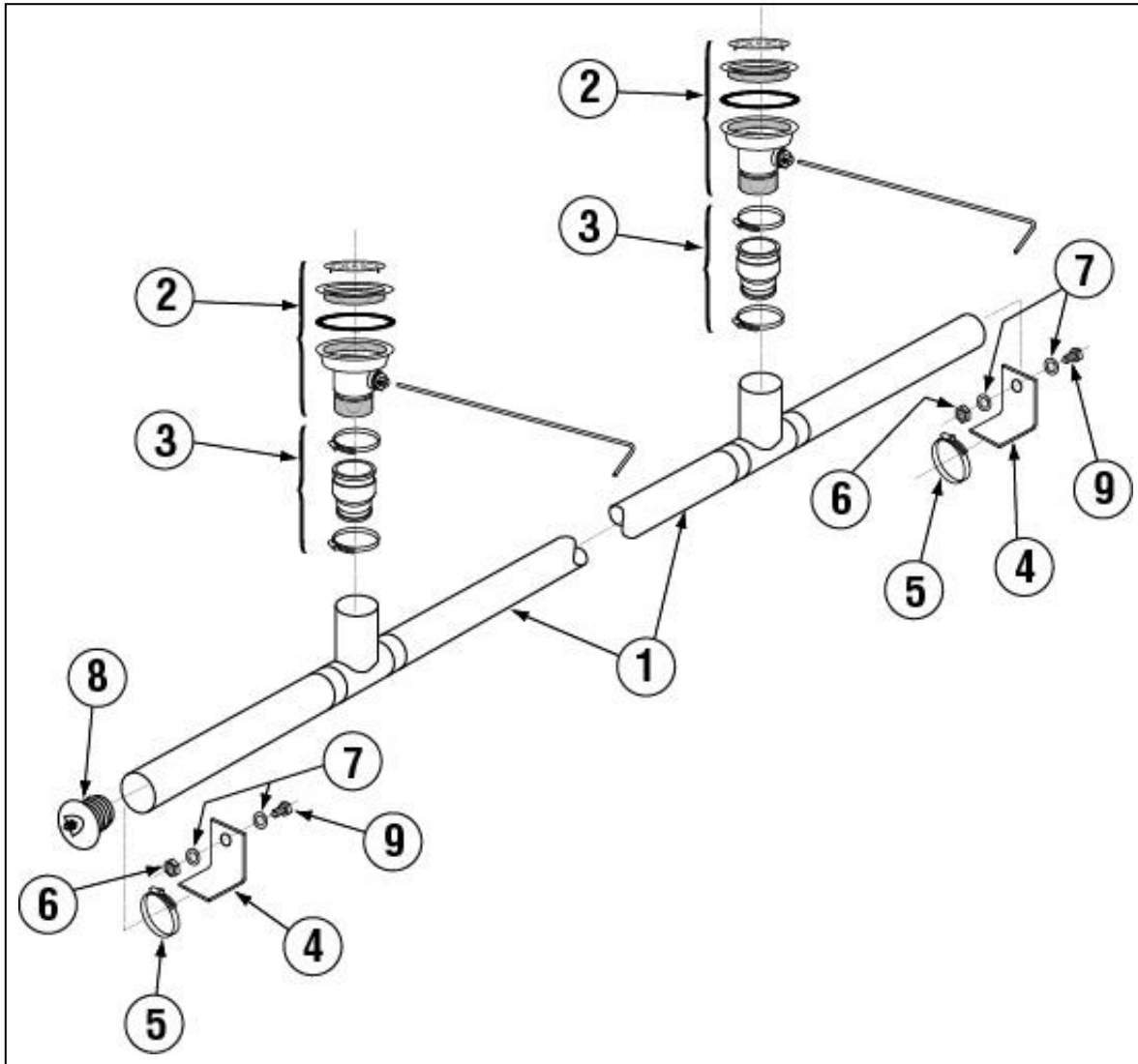

ITEM NO.	NO. REQ'D	P/N	DESCRIPTION
1	1	13001.85	Drain Manifold
2	2	20500.06	Waste Drain Valve
3	2	01317.17	1-1/2" x 2" No Hub
4	2	13001.26	Drain Support Bracket
5	2	50109.00	Hose Clamp

ITEM NO.	NO. REQ'D	P/N	DESCRIPTION
6	2	00912.00	1/4-20 Lock Nut
7	4	00924.00	1/4" Washer, SS
8	1	13024.00	Dynamite Plug, 2"
9	2	00906.0	1/4-20 x 1/2" Hex Head Bolt

Parts Manual

5.2.11. Plumbing System Assembly (Auto-Fill)

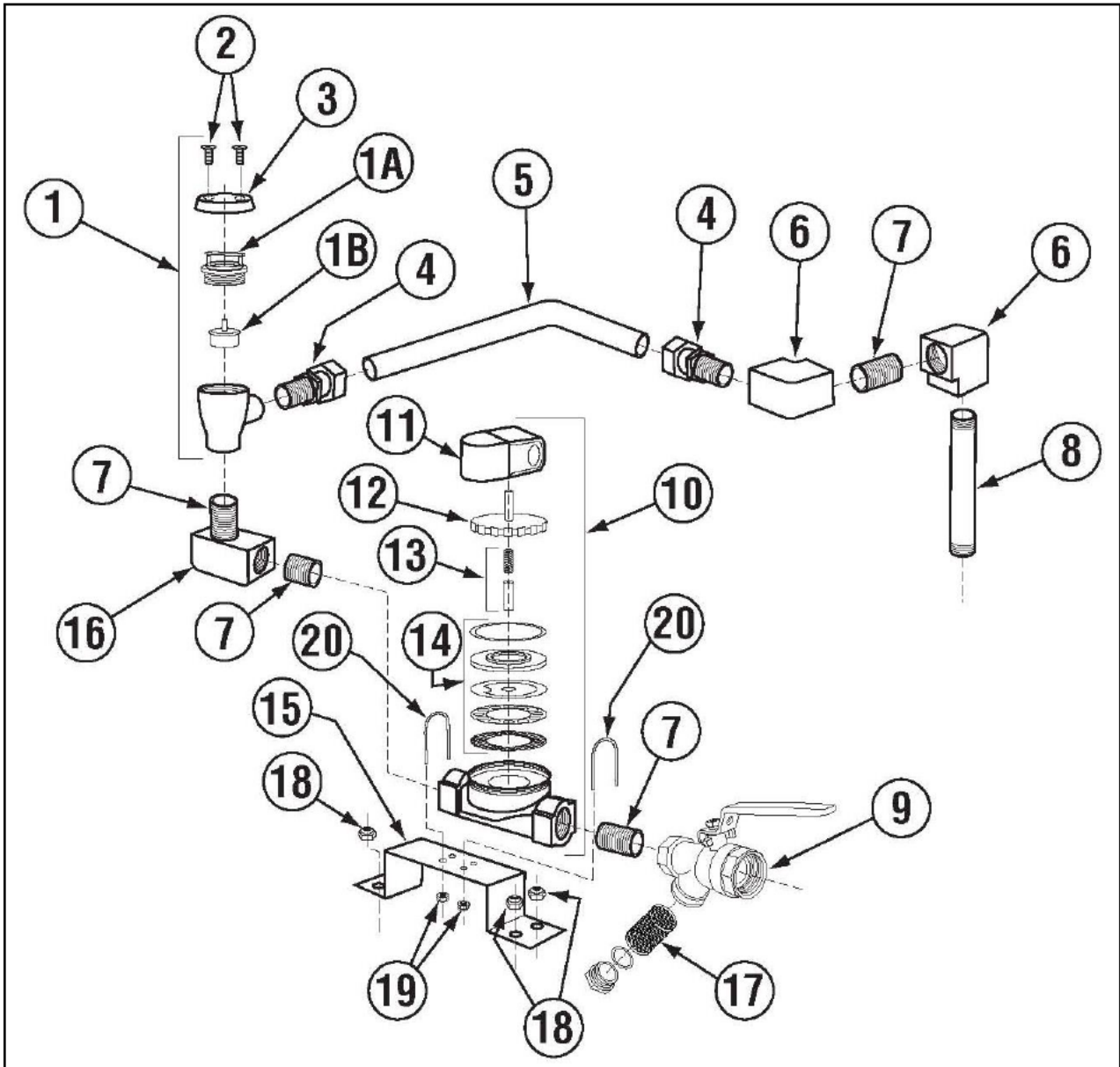

ITEM NO.	NO. REQ'D	P/N	DESCRIPTION
1	1	03624.00	1/2" Vacuum Breaker, Watts**
1A	1	03624.25	1/2" Vacuum Breaker Bonnet
1B	1	03623.00	1/2" Vacuum Breaker Repair Kit
2	2	00421.51	6-32 x 1/4" SS Panhead Screw
3	1	00739.50	Vacuum Breaker Cap
4	2	00760.00	5/8 Comp x 1/2 MIP Adapter
5	1	13608.00	EST-44 Water Inlet Tube SS
6	2	41030.10	1/2 90 Deg Ell Fx F Brass
7	3	00742.00	Nipple Brass 1/2 x 1 1/2
8	1	00747.10	Nipple Brass 1/2 x 5
9	1	41062.00	1/2 Strainer Ball Valve*

ITEM NO.	NO. REQ'D	P/N	DESCRIPTION
10	1	03603.15	1/2" Water Solenoid Valve 220V, JE
11	1	00738.15	Water Solenoid Valve Coil, 220V, 3/4" & 1/2"
12	1	03603.20	1/2" Water Solenoid Valve Bonnet
13	1	00786.00	Water Solenoid Plunger with Spring
14	1	00707.00	1/2" Water Solenoid Valve Repair Kit
15	1	01525.06	Plumbing Support Bracket
16	1	00745.00	1/2 90 Deg Street E bow
17	1	41062.10	1/2 Ball Valve Strainer
18	4	00912.00	1/4-20 Nylon Lock Nut
19	4	00912.00	1/4-20 Nylon Lock Nut
20	2	01526.10	Plumbing Bracket Strap

Parts Manual

5.2.12. Plumbing System Assembly (Final Rinse)

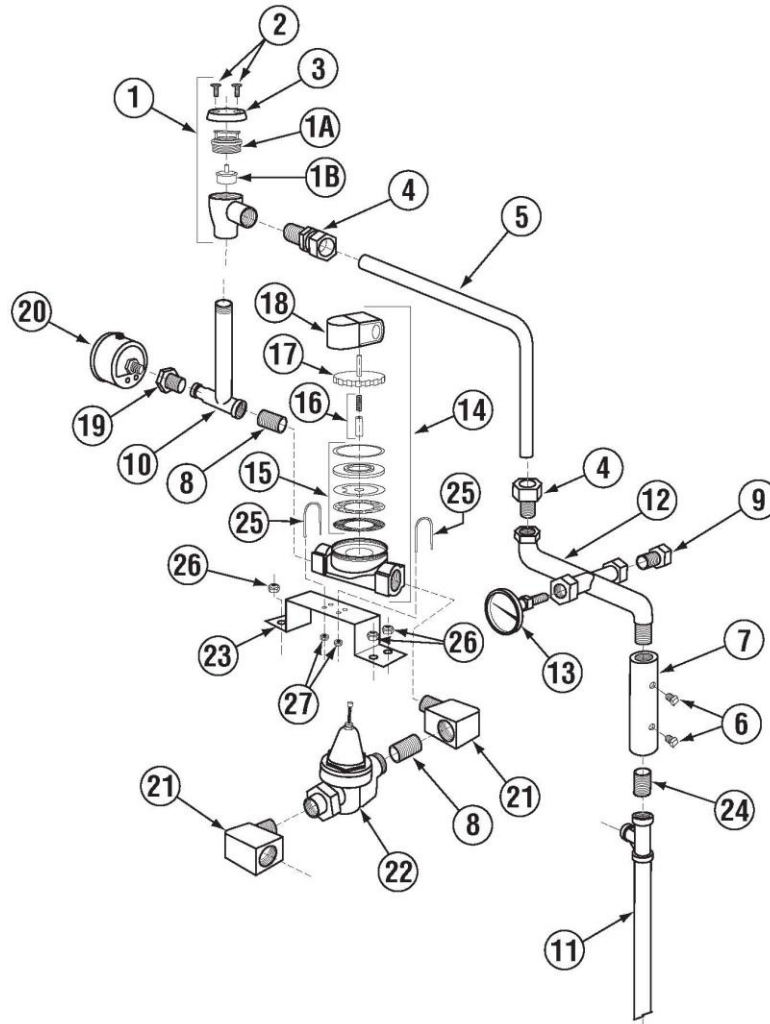

ITEM NO.	NO. REQ'D	P/N	DESCRIPTION
1	1	03624.00	1/2" Vacuum Breaker, Watts**
1A	1	03624.25	1/2" Vacuum Breaker Bonnet
1B	1	03623.00	1/2" Vacuum Breaker Repair Kit
2	2	00421.51	6-32 x 1/4" SS Panhead Screw
3	1	00739.50	Vacuum Breaker Cap
4	2	00760.00	5/8 Comp x 1/2 MIP Adapter
5	1	13608.50	44 Final Rinse Plumbing Tube
6	2	03232.00	1/8 Male Plug
7	1	13669.21	Mixing Chamber SS
8	3	00742.00	Nipple Brass 1/2 x 1 1/2
9	1	13631.50	Plumbing Connection Plug
10	1	13644.00	EST Vacuum Breaker Conn.
11	1	13307.30	EST44/66 Final Rinse Tube Assy.
12	1	13631.00	Mixing Chamber Plumbing Connect
13	1	00120.02	Bi Metal Thermometer

ITEM NO.	NO. REQ'D	P/N	DESCRIPTION
14	1	03603.15	1/2" Water Solenoid Valve 220V, JE*
15	1	00707.00	1/2" Water Solenoid Valve Repair Kit
16	1	00786.00	Water Solenoid Plunger with Spring
17	1	03603.20	1/2" Water Solenoid Valve Bonnet
18	1	00738.15	Water Solenoid Valve Coil, 220V, 3/4" & 1/2"
19	1	13604.00	1/2 x 1/4 Bushing Brass
20	1	13605.45	Pressure Gauge (CMA-180)
21	3	00745.00	1/2 90 Deg Street Elbow
22	1	13602.20	1/2" Pressure Regulator
23	1	01525.06	Plumbing Support Bracket
24	3	13629.00	Nipple SS 1/2 x Close
25	2	01526.10	Plumbing Bracket Strap
26	4	00912.00	1/4-20 Nylon Lock Nut
27	4	00912.00	1/4-20 Nylon Lock Nut

Parts Manual

5.2.13. Wash System Assembly

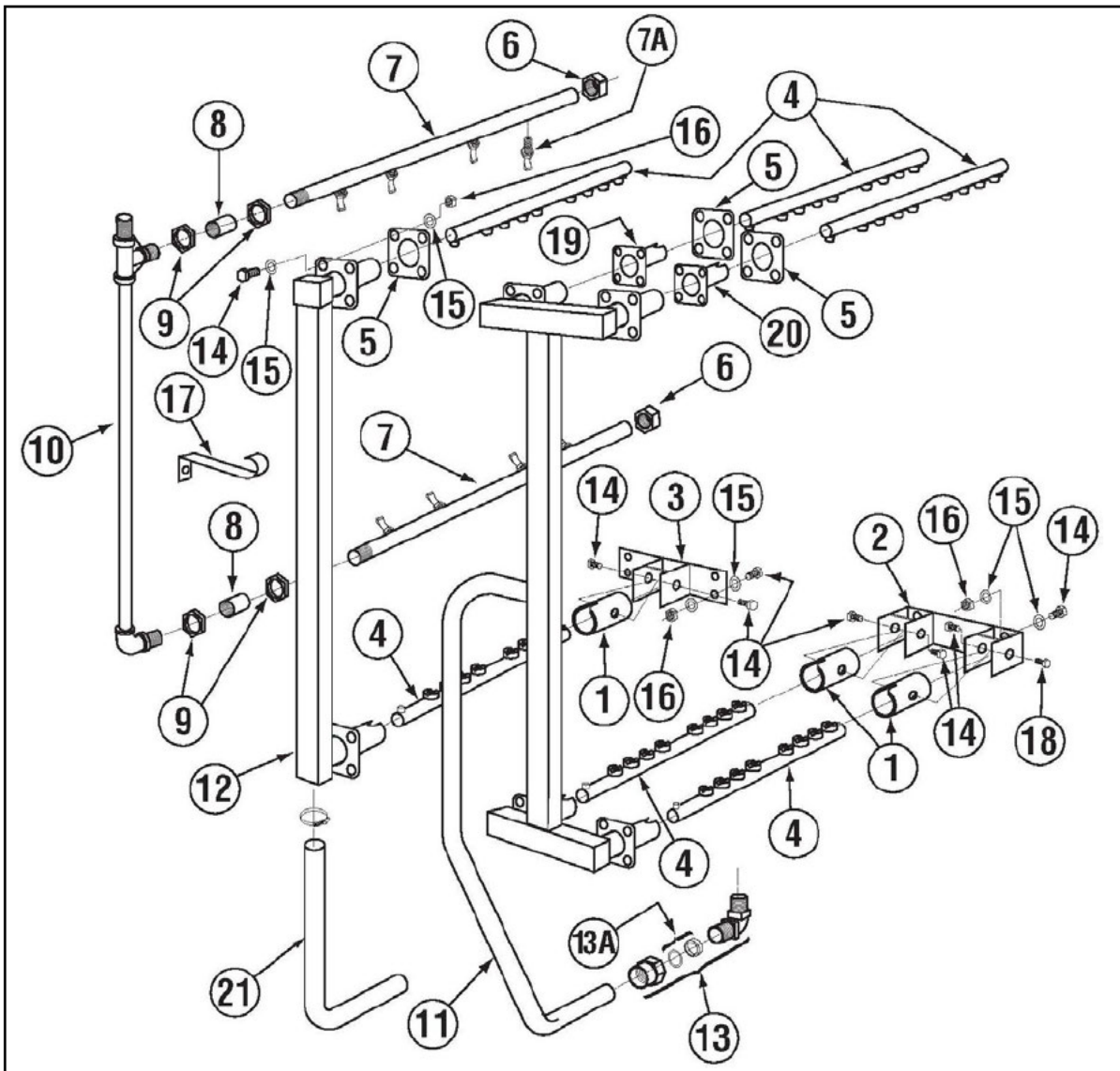

ITEM NO.	NO. REQ'D	P/N	DESCRIPTION
1	6	13305.06	Spray Arm End Cap
2	2	13327.06	Socket Bracket, Double
3	2	13327.26	Socket Bracket, Single
4	6	13303.17	Spay Arm
5	6	04306.10	Square Manifold Gasket
6	2	13310.00	1/2" Cap, Brass
7	2	13304.83	Final Rinse Spay Arm*
7A	8	13304.66	Final Rinse Spray Jets, SS
8	2	13618.00	1/2" Coupling
9	4	00721.20	1/2" Jamb Nut, Brass
10	1	13307.30	EST44/66 Final Rinse Tube Assy.
11	1	13301.16	Wash Manifold 03/15

ITEM NO.	NO. REQ'D	P/N	DESCRIPTION
12	1	13301.39	Rinse Manifold
13	1	00213.00	1" Ford Adapter, MIP x PJ Tube**
13A	1	00225.00	1" Compression Gasket
14	36	0914.10	1/4-20 x 5/8 Hexhead Bolt 304SS
15	36	00924.00	1/4" SS Washer
16	36	00912.00	1/4-20 Nylon Lock Nut
17	1	13304.53	Long Support Bracket
18	12	13305.40	Shoulder Bolt
19	1	13301.32	Upper Wash Arm Socket Left
20	1	13301.33	Upper Wash Arm Socket Right
21	1	03108.66	Transfer Hose 1" - 35"

Parts Manual

5.2.14. Rocker Arm Assembly

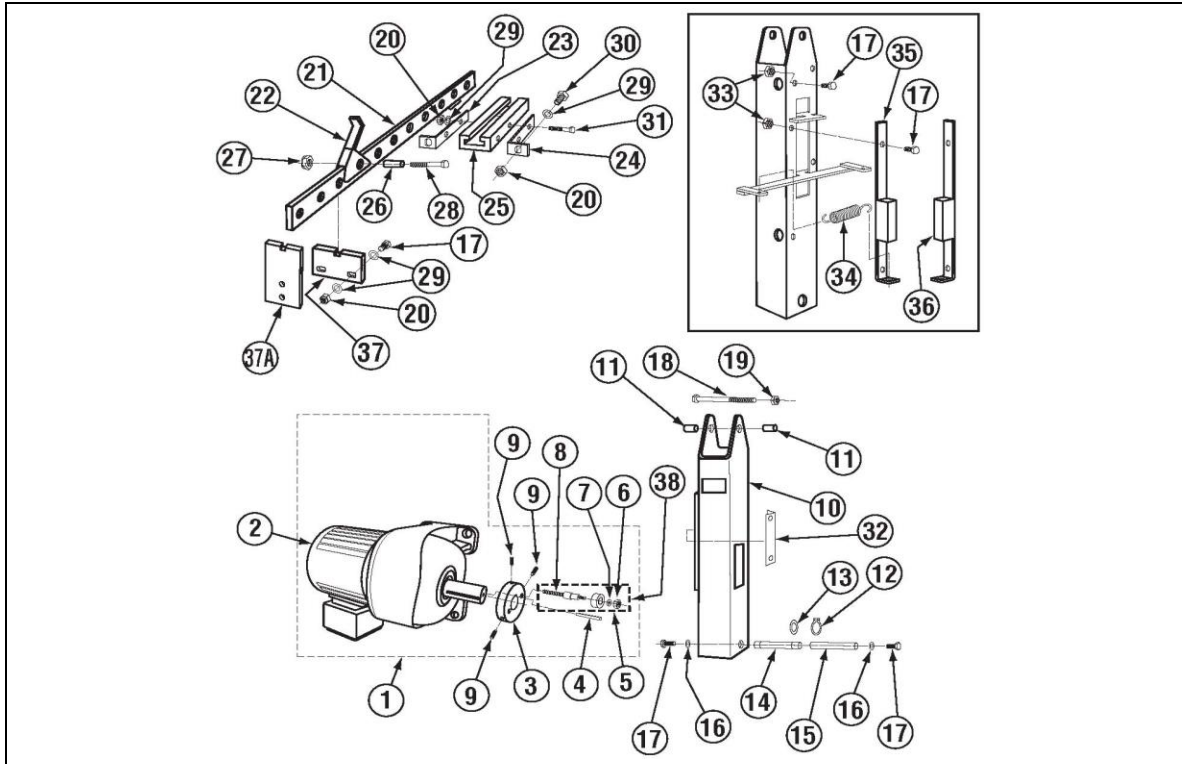

ITEM NO.	NO. REQ'D	P/N	DESCRIPTION
1	1	13571.00	EST Conveyor Drive Assy.3ph,230V
		13571.25	EST Conveyor Drive Assy.1ph,230V
2	1	13503.06	EST-44 Gearbox Motor Assy.3ph,230V
		13503.08	EST-44 Gearbox Motor Assy.1ph,230V*
3	1	13505.14	EST-44 Drive Cam
4	1	13505.22	Keyway (Cam)
5	1	13507.20	Cam Bearing Only
6	1	13805.00	5/16-18 Nylon Insert Lock Nut
7	1	13507.11	Cam Bearing Shaft Spacer
8	1	13507.12	Cam Bearing Shaft
9	3	00935.22	1/4-20 x 1/2" Set Screw
10	1	13508.12	CMA 44 Rocker Arm
11	2	13513.10	Rocker Arm Spacer
12	2	13509.52	7/8" ID External Lock Ring
13	2	13509.53	1" ID Brass Washer
14	1	13509.12	CMA 44 Rocker Shaft Bearing
15	1	13510.10	Bearing Shaft
16	2	00922.00	1/4" Lock Star Washer
17	4	00914.00	1/4-20 x 3/4" Hex Head Bolt
18	1	13808.00	1/2-13 x 3-1/2"
19	1	13809.00	1/2-13 Nylon Lock Nut

ITEM NO.	NO. REQ'D	P/N	DESCRIPTION
20	1	00912.00	1/4-20 Nylon Lock Nut
21	1	13514.87	Conveyor Bar (11 Dogs)
22	11	13515.00	Conveyor Dog, SS
23	1	13514.82	Left Conveyor Bar Bracket
24	1	13514.84	Right Conveyor Bar Bracket
25	1	13521.50	Conveyor Bar Slide Bearing
26	11	13520.00	Conveyor Dog Bearing
27	11	13806.00	3/8" Nylon Lock Nut
28	11	13818.00	3/8-16 x 1-3/4" Hex Head Bolt
29	2	00924.00	1/4" SS Washer
30	2	00914.10	1/4-20 x 5/8" Hex Head Bolt
31	1	00903.00	1/4-20 x 1-3/4" Hex Head Bolt
32	1	13505.06	Cam Guide
33	4	00912.00	1/4-20 Nylon Lock Nut**
34	1	13508.70	Heavy Duty Clutch Spring
35	1	13508.22	Rack Saver Clutch Bar L>R (2 Spring)
36	1	13508.28	Rack Saver Clutch Bar R>L (2 Spring)
37	1	13522.00	Conveyor Bar Guide Starting 11/02
37A	1	13522.10	Conveyor Bar Guide Starting 01/11
38	1	13507.65	Cam Bearing Assy. (12/07)

* Comes with capacitor P/N 13503.03

Parts Manual

5.2.15. Start Switch and Rinse Switch Assembly (Effective May 2014)

5.2.15.1. Right-to-Left Assembly

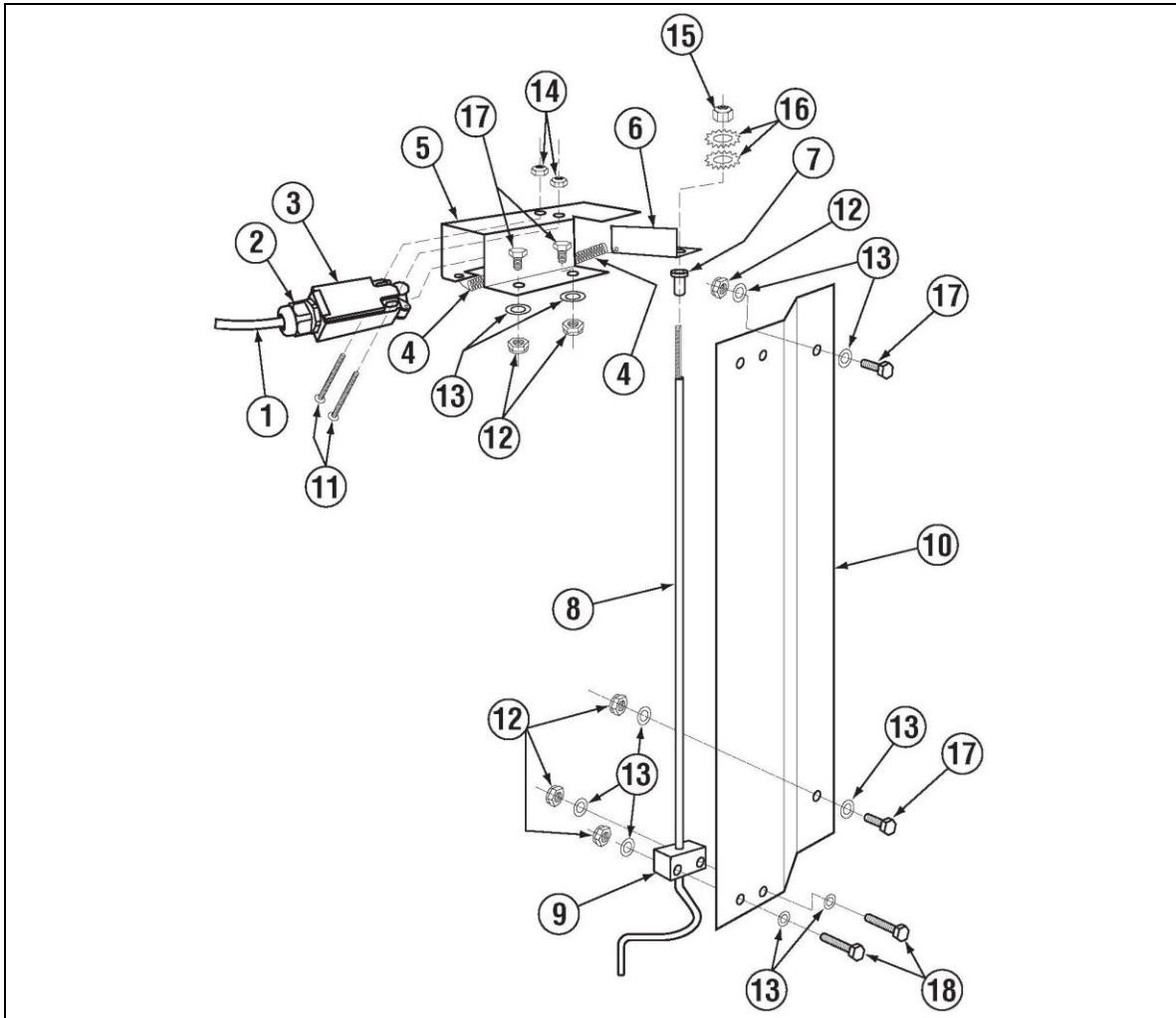

ITEM NO.	NO. REQ'D	P/N	DESCRIPTION
1	8'	00547.00	Switch Cord 18 AWG SOOW
2	2	00562.60	Connector-#562 Door Roller Switch
3	2	00562.00	Roller Door Switch
4	2	13408.64	Table Limit Switch Bracket Spring
5	2	13975.00	Conveyor Switch Housing R-L
6	2	13976.00	Conveyor Switch Activator Brkt R-L
7	2	13972.10	Conveyor Switch Rod Sleeve
8	2	13972.00	Conveyor Switch Rod R-L
9	2	13974.00	Conveyor Switch Rod Block UHMW

ITEM NO.	NO. REQ'D	P/N	DESCRIPTION
10	1	13973.00	Final Rinse Rod Shield (final rinse only)
11	2	00960.00	8-32 X 1 1/2 Panhead Screw
12	10	00912.00	1/4-20 Nylon Lock Nut
13	20	00926.00	5/16 SS Washer
14	4	00927.00	8-32 Nylon Lock Nut
15	2	00913.00	5/16-18 SS Nut
16	4	03807.30	5/16 External Lock Washer
17	6	00914.10	1/4-20 x 5/8 Hexhead Bolt 304SS
18	4	00910.00	1/4-20 x 1 1/2 SS Hexhead Bolt

Parts Manual

5.2.15.2. Left-to-Right Assembly

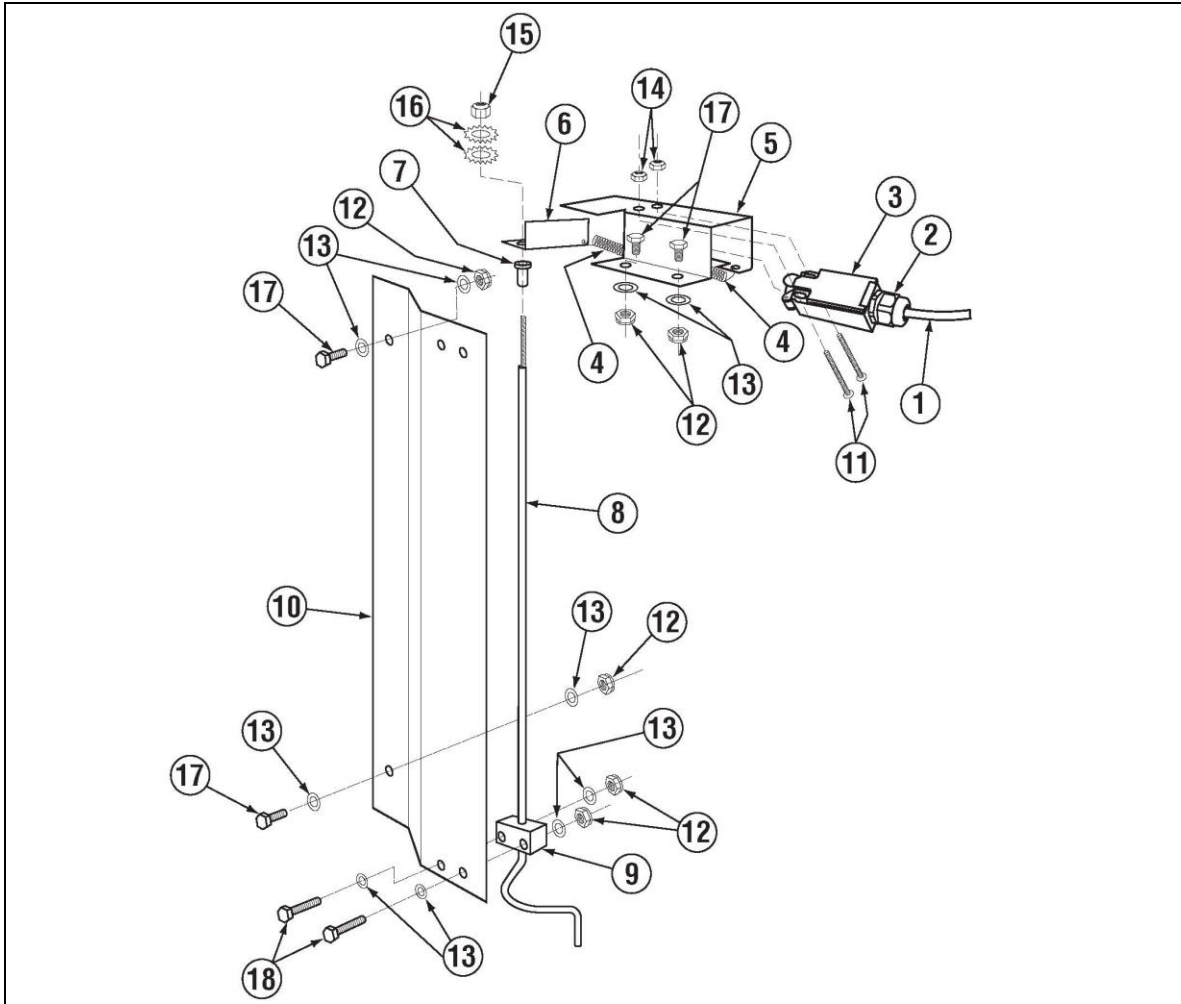

ITEM NO.	NO. REQ'D	P/N	DESCRIPTION
1	8'	00547.00	Switch Cord 18 AWG SOOW
2	2	00562.60	Connector-#562 Door Roller Switch
3	2	00562.00	Roller Door Switch
4	2	13408.64	Table Limit Switch Bracket Spring
5	2	13975.50	Conveyor Switch Housing L-R
6	2	13976.50	Conveyor Switch Activator Brkt L-R
7	2	13972.10	Conveyor Switch Rod Sleeve
8	2	13972.50	Conveyor Switch Rod L-R
9	2	13974.00	Conveyor Switch Rod Block UHMW

ITEM NO.	NO. REQ'D	P/N	DESCRIPTION
10	1	13973.00	Final Rinse Rod Shield (final rinse only)
11	2	00960.00	8-32 X 1 1/2 Panhead Screw
12	10	00912.00	1/4-20 Nylon Lock Nut
13	20	00926.00	5/16 SS Washer
14	4	00927.00	8-32 Nylon Lock Nut
15	2	00913.00	5/16-18 SS Nut
16	4	03807.30	5/16 External Lock Washer
17	6	00914.10	1/4-20 x 5/8 Hexhead Bolt 304SS
18	4	00910.00	1/4-20 x 1 1/2 SS Hexhead Bolt

5.2.16. Start Switch and Rinse Switch Assembly

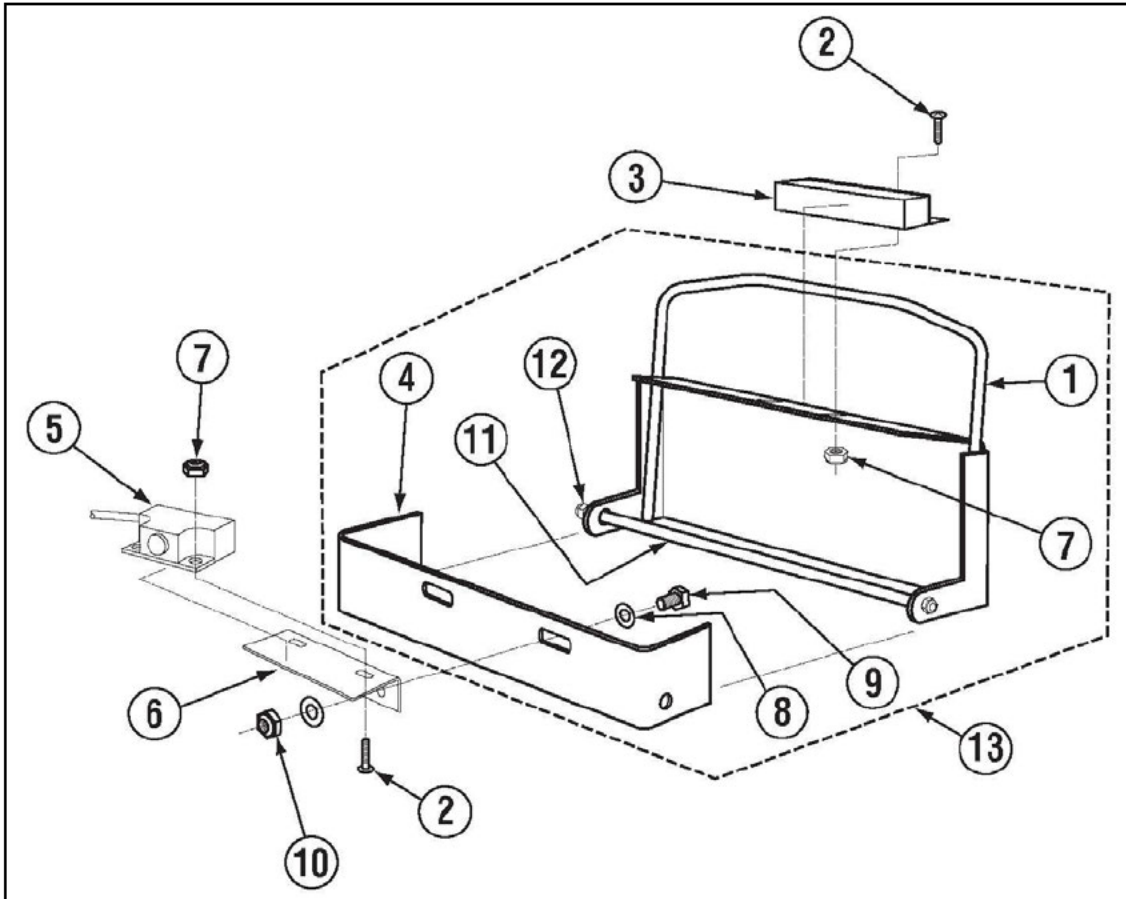

ITEM NO.	NO. REQ'D	P/N	DESCRIPTION
1	1	13408.61	Actuator Arm
2	4	00907.50	6-32 x 3/8" Pan Head Screw
3	1	00556.60	Reed Switch Magnet-ISI
4	1	13408.62	Actuator Bracket
5	1	00556.10	Reed Switch-ISI
6	1	13409.31	Reed Switch Bracket
7	4	00965.00	6-32 Nylon Lock Nut
8	4	00924.00	1/4" SS Washer
9	4	00906.00	1/4" -20 x 1/2" Hex Head Bolt
10	4	00912.00	1/4" - 20 Nylon Lock Nut
11	1	13408.59	Actuator Arm Shaft
12	2	13805.00	5/16" Nylon Lock Nut
13	1	13408.60	Actuator Assy.

5.2.17. Door Switch Assembly (Effective August, 2014)

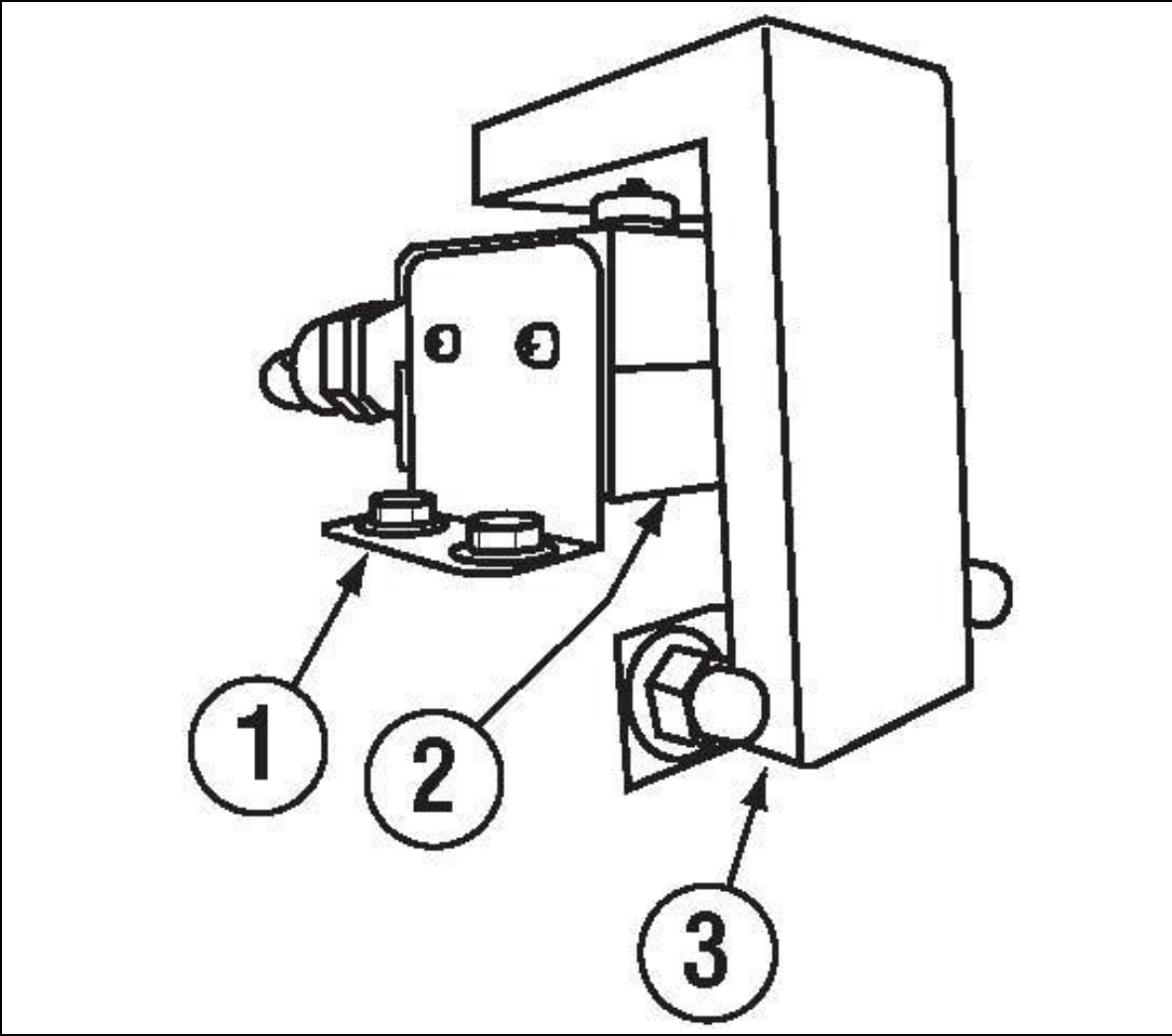

ITEM NO.	NO. REQ'D	P/N	DESCRIPTION
1	1	00471.87	Est44/66 Door Safety Switch Brkt
2	1	13427.10	Table Limit Switch (Push Button)
3	1	00471.88	Est44/6 Door Switch Actuator Bracket

Parts Manual

5.2.18. Optional E-Temp Heater (Effective September 1, 2018)

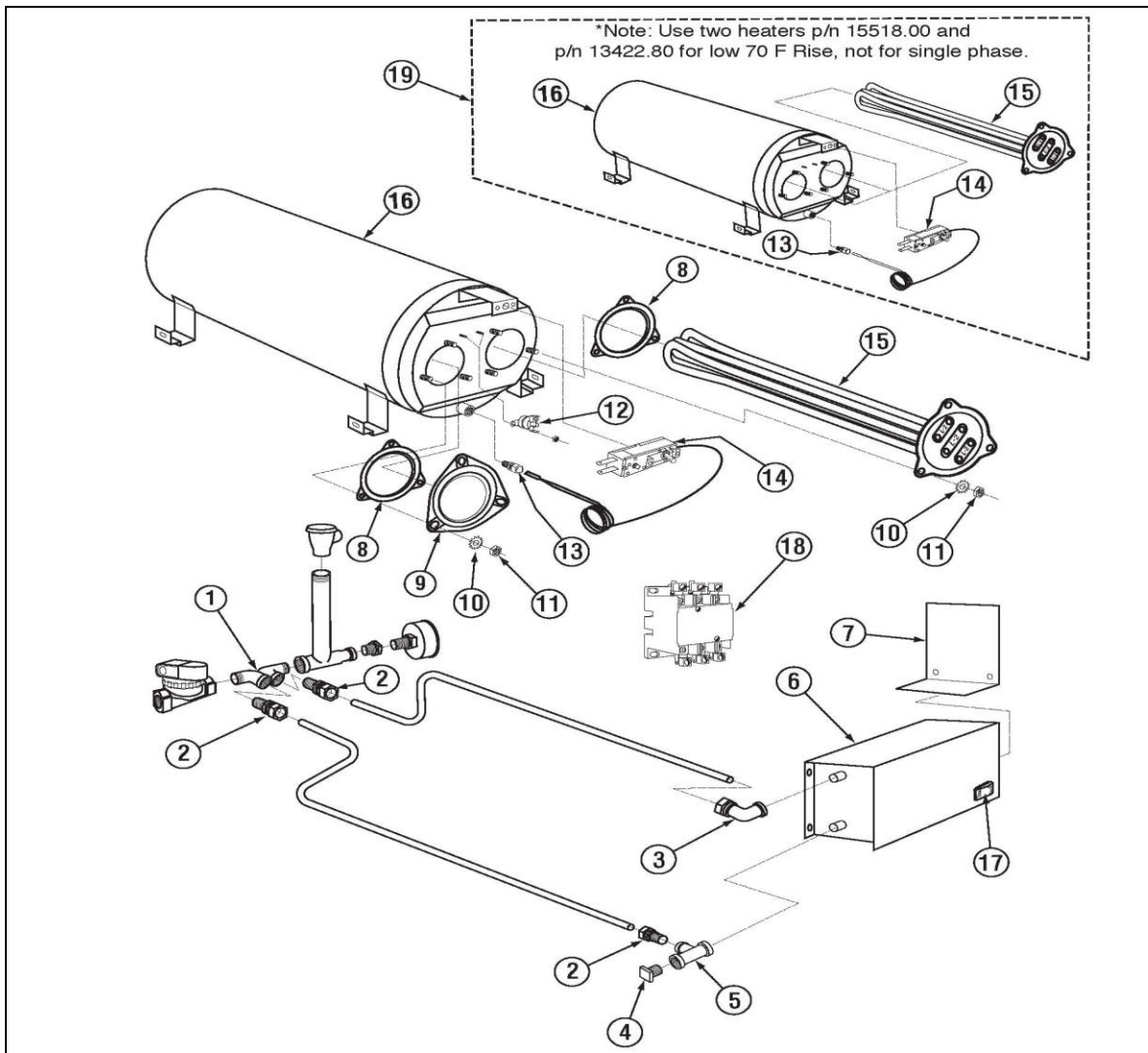

ITEM NO.	NO. REQ'D	P/N	DESCRIPTION
1	1	13620.20	Booster Heater 1/2 In/Out Adapter
2	3	00760.00	5/8 Comp x 1/2 MIP Adapter
3	1	17550.10	Inlet Booster Heater Plumbing Connt
4	1	13642.00	1/2" MIP Plug Brass Sq. Head
5	1	00743.10	1/2 Tee F x F x F Brass
6	1	13951.10	E-Temp Booster Shroud - Zoppas
7	1	13951.12	E-Temp Booster Access Cover
8	2	15518.11	Gasket for Triangular Flange Heater
9	1	13950.20	E-Temp Tank Plug for 40F Rise.
10	6	00924.00	1/4 SS Washer

ITEM NO.	NO. REQ'D	P/N	DESCRIPTION
11	6	00912.00	1/4-20 Nylon Lock Nut
12	1	17523.51	Hi Limit Switch 250Deg
13	1	40116.00	1/4 Comp x 1/4 MIP Ftg
14	1	13417.89	Heater Thermostat
15	1	13422.71	240V 12KW Trianguler Immersion Htr*
16	1	13422.76	480V 6KW Trianguler Immersion Htr*
17	1	13951.20	E-Temp Heater Tank
18	1	00421.83	Power Rocker Switch, Red
19	1	13003.17	Contactur 60 Amp 3 Pole
20	1	13951.60	E-Temp Tank Assy 70Deg Rise

* Note : Use two heaters p/n [15518.00](#) and [13422.80](#) for 70 F Rise., not for single phase.

Parts Manual

5.2.19. Optional E-Temp Heater

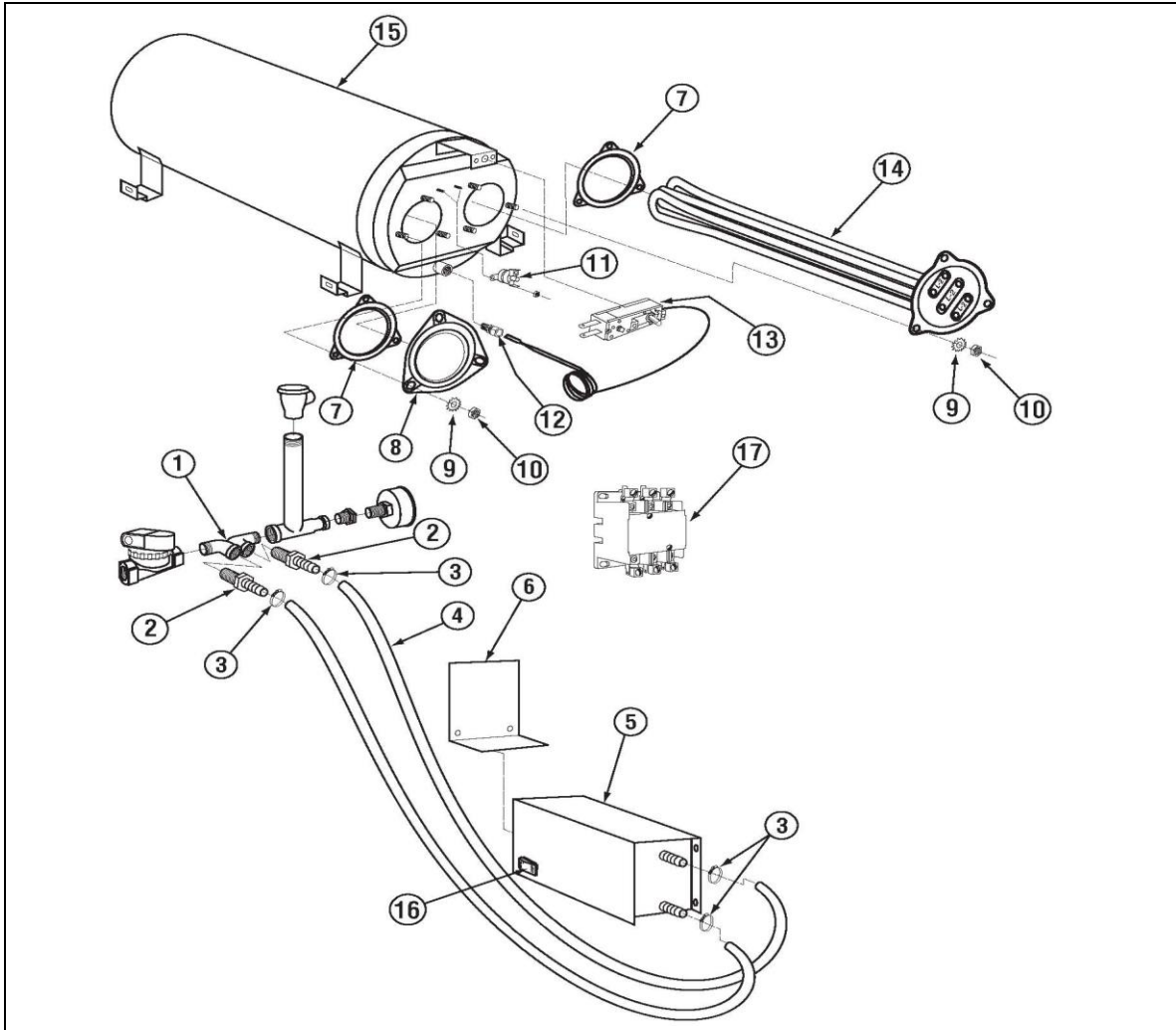

ITEM NO.	NO. REQ'D	P/N	DESCRIPTION
1	1	13620.20	Booster Heater 1/2 In/Out Adapter
2	2	40014.00	1/2m x 1/2 Barb Straight
3	4	03101.47	Hose Clamp # 6 size # 003
4	2	03107.62	Flexible Hose 1/2" X5 Ft
5	1	13951.10	E-Temp Booster Shroud - Zoppas
6	1	13951.12	E-Temp Booster Access Cover
7	2	15518.11	Gasket for Triangular Flange Heater
8	1	13950.20	E-Temp Tank Plug for 40F Rise.
9	6	00924.00	1/4 SS Washer

ITEM NO.	NO. REQ'D	P/N	DESCRIPTION
10	6	00912.00	1/4-20 Nylon Lock Nut
11	1	17523.51	Hi Limit Switch 250Deg
12	1	40116.00	1/4 Comp x 1/4 MIP Ftg
13	1	13417.89	Heater Thermostat
14	1	13422.71	240V 12KW Triangular Immersion Htr*
15	1	13951.20	E-Temp Heater Tank
16	1	00421.83	Power Rocker Switch, Red
17	1	13003.17	Contactors 60 Amp 3 Pole

* Note : Use two heaters p/n [15518.00](#) and [13422.80](#) for 70 F Rise., not for single phase.

Parts Manual

5.2.20. Unique Parts For EST-44 Tall machines.

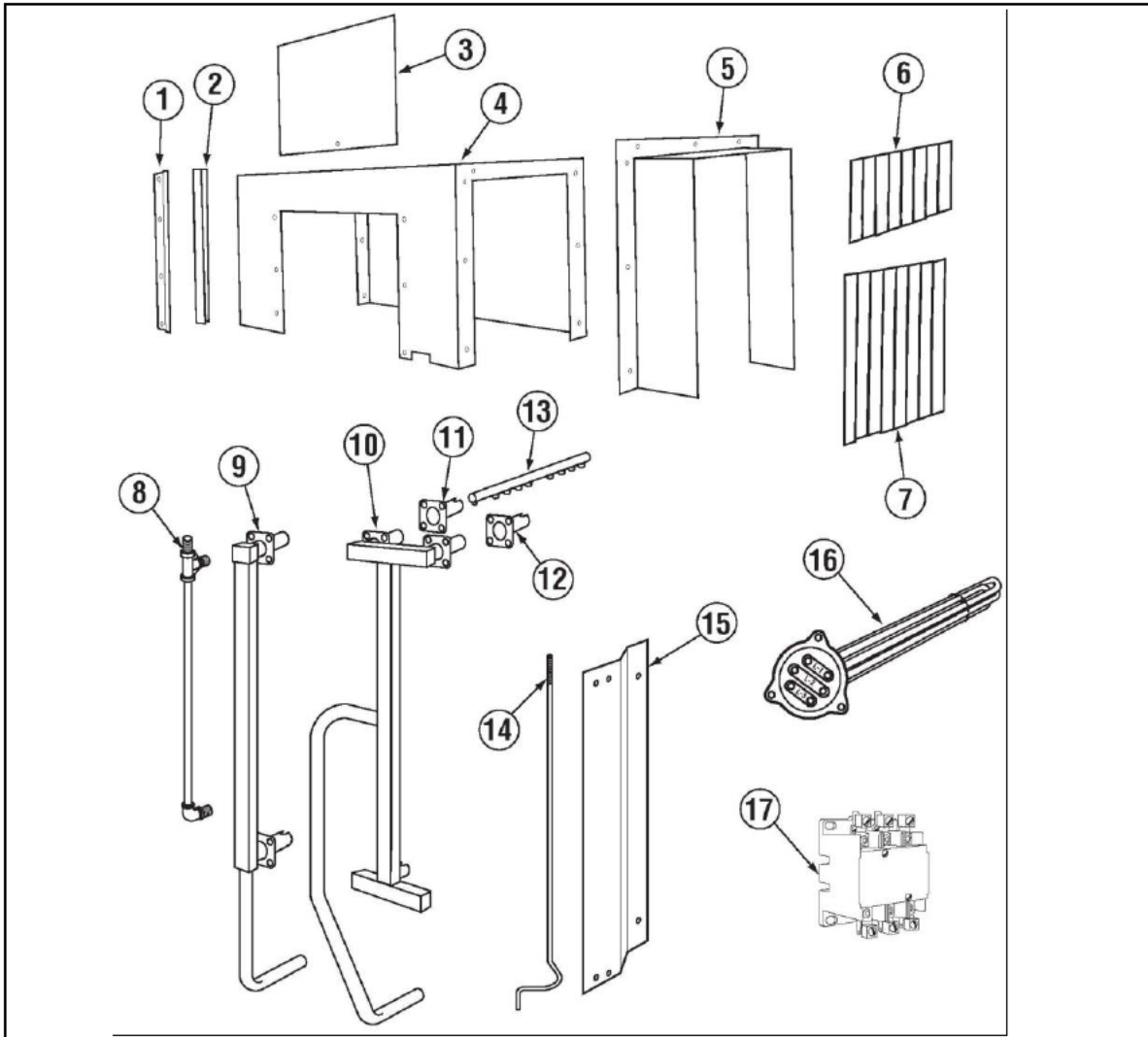

ITEM NO.	NO. REQ'D	P/N	DESCRIPTION
1	2	13936.50	Conveyor Door Guide 6" Taller
2	2	00636.30	EZ Glide Door Guide 32 1/4"
3	1	13936.00	Conveyor Door 6" Taller
4	1	13935.00	EST- 44 Wrapper L-R 6" Taller
	1	13935.50	EST- 44 Wrapper R-L 6" Taller
5	2	13938.00	Conveyor Wrapper Shield 6" Taller
6	1	13702.30	Curtain CMA-44 24 5/8" x 15
7	2	13703.61	Curtain CMA-44/66 20 5/8 x 21
8	1	13307.32	^EST-44/66 Final Rinse Tube Tall
9	1	13937.57	Conveyor Rinse Mani L-R 6" Taller
	1	13937.58	Conveyor Rinse Mani R-L 6" Taller

ITEM NO.	NO. REQ'D	P/N	DESCRIPTION
10	1	13938.16	Conveyor Wash Manifold Tall 03/16
11	1	13301.35	Upper Wash Arm Socket Left Tall
12	1	13301.36	Upper Wash Arm Socket Right Tall
13	6	13303.26	^Spray Arm CMA-44P (Special) .175
14	2	13972.60	Conveyor Switch Rod L-R Tall
	2	13972.20	Conveyor Switch Rod R-L Tall
15	1	13973.50	Final Rinse Rod Shield Tall
16	1	13422.84	Immersion Heater 15Kw 208V T-Flange
17	1	13003.17	Contactor 60 Amp 3 Pole

6. Table Limit Switch (P/N 13469.20)

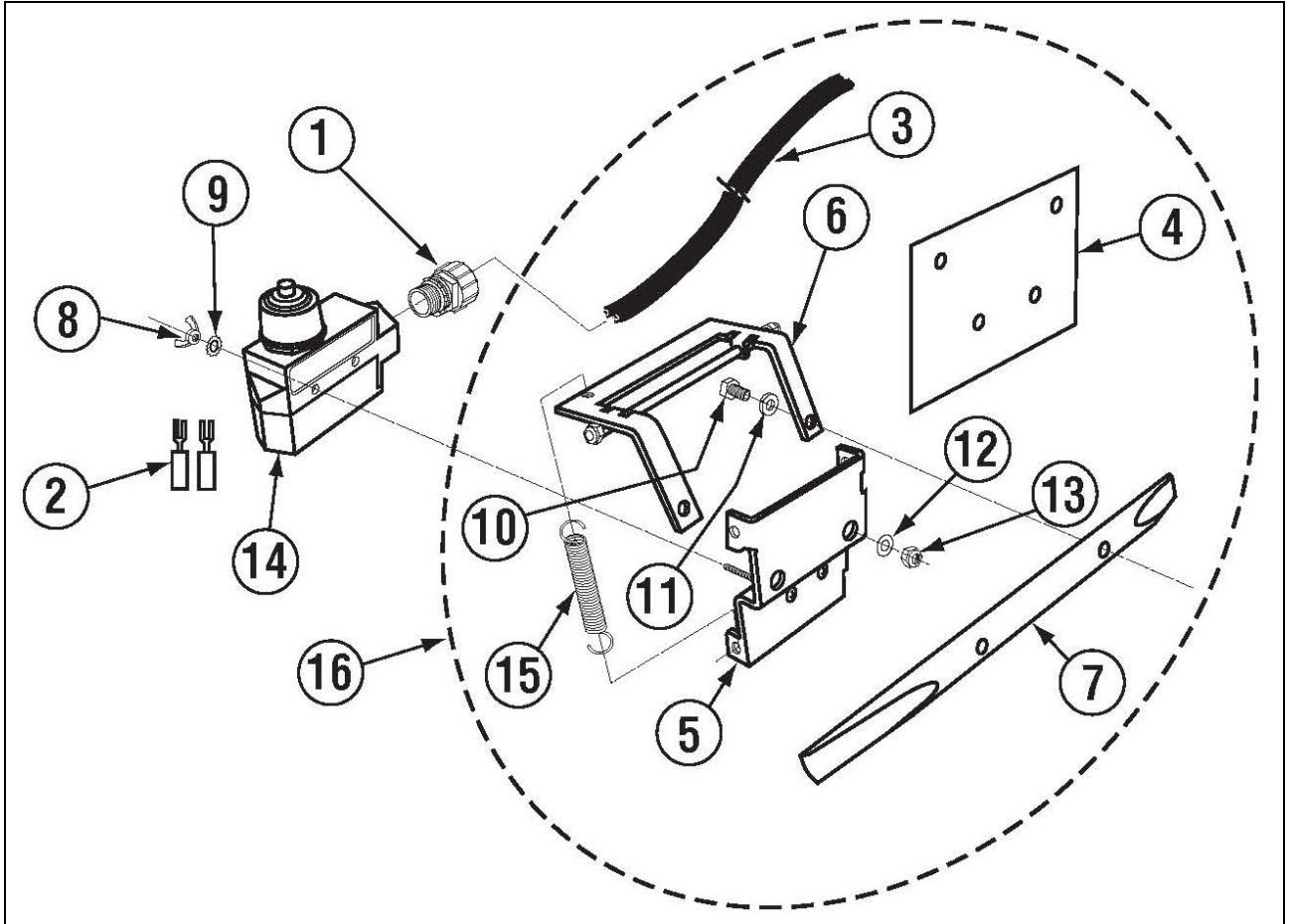

ITEM NO.	NO. REQ'D	P/N	DESCRIPTION
1	1	13427.12	Connector for Table Limit Switch
2	2	00446.60	Ring Eyelet Connector 14-16 #8
3	14 FT	00547.00	Switch Cord 18 AWG SOOW
4	1	13427.60	Template kit
5	1	13427.61	Mounting bracket
6	1	13427.62	Actuator
7	1	13427.63	Bumper
8	2	03817.00	6-32 wing nut
9	2	03814.10	Lock star washer
10	2	00914.10	1/4-20 x 5/8 hexhead bolt
11	2	00968.00	1/4 split lock washer
12	2	00924.00	1/4 ss washer
13	2	00912.00	1/4-20 nylon lock nut
14	1	13427.10	Limit switch
15	1	13408.64	Switch Bracket Spring
16	1	13427.50	Table Limit Switch Bracket Ass'y

7. Drain Water Tempering Kit (Optional)

CMA-180, EST-44, EST-66 WATER TEMPERING VALVE KIT P/N 13470.10

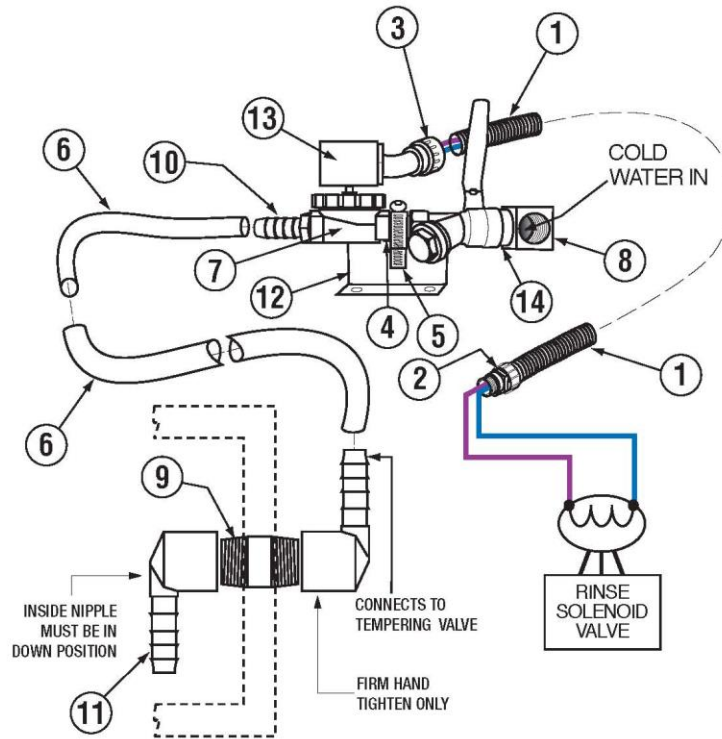

ITEM NO.	P/N	NO REQ'D	DESCRIPTION
1.	00400.00	2	CONDUIT 3/8" SEALTITE
2.	00401.00	1	ST-3/8" STRAIGHT CONNECTOR
3.	00402.00	1	ST-90 DEG 3/8" COONNECTOR
4.	00742.00	1	NIPPLE BRASS 1/2X1-1/2"
5.	03101.00	1	HOSE CLAMP #16 1"
6.	03106.45	5	BRAIDED HOSE 1/2"
7.	03603.15	1	WATER SOLENOID VALVE 1/2"
8.	41030.10	1	1/2" 90 DEG. ELL X F BRASS
9.	13472.00	1	NIPPLE PVC 1/2"X CLOSE
10.	13472.40	1	ADAPTER PVC 1/2" MALE X 1/2" BARB
11.	13472.50	2	ELBOW PVC 90 DEG F X BARB
12.	14508.50	1	PLUMBING BRACKET (180-UC)
13.	00738.15	1	SOLENOID VALVE COIL 220V
14.	41062.00	1	1/2" STRAINER BALL VALVE

2-2013

Parts Manual

Drain Water Tempering Valve Assembly (Effective 03-2023)

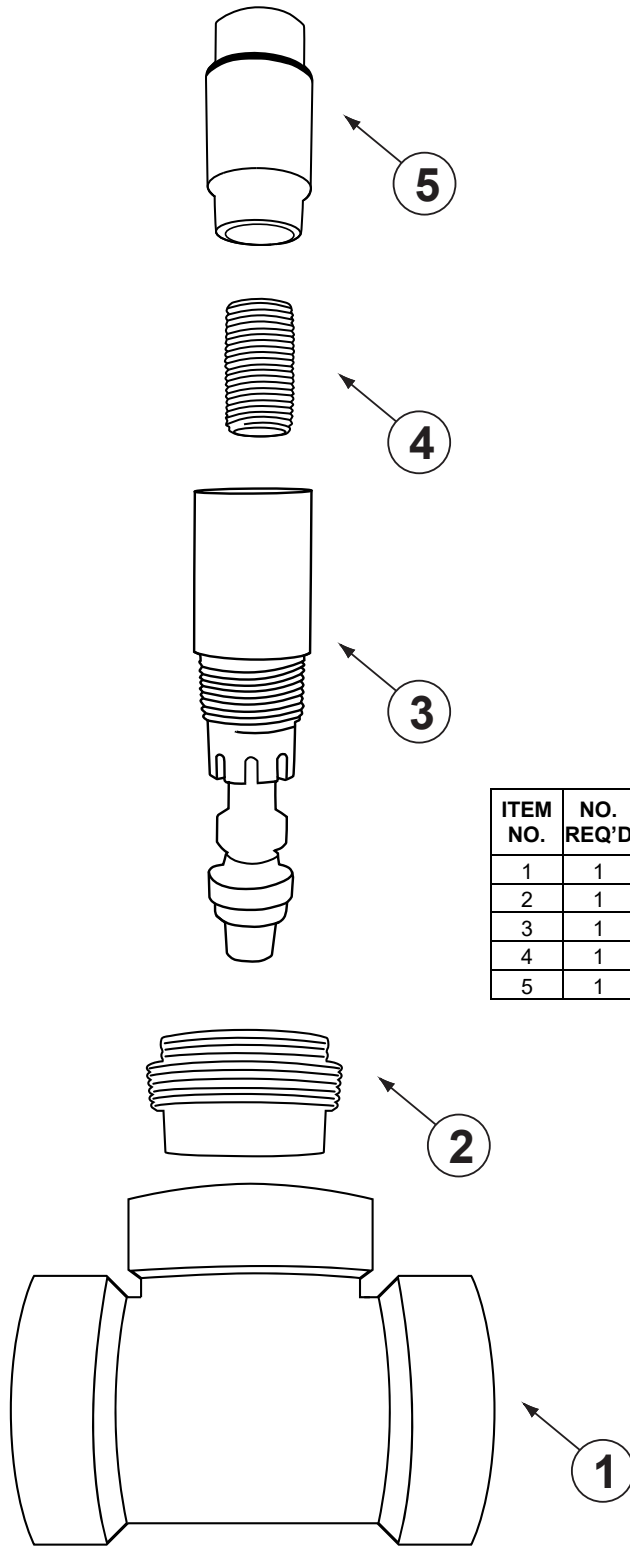

ITEM NO.	NO. REQ'D	P/N	DESCRIPTION
1	1	13470.88	2 ABS Tee S x S x MIP
2	1	13470.87	DTV Adapter 2" X 3/4"
3	1	13470.85	Drain Water Tempering Valve
4	1	00742.00	Nipple Brass 1/2 x 1-1/2
5	1	00715.00	1/2 Ball Check Valve

8. Electrical Diagram For 240V, 3 phase EST-44

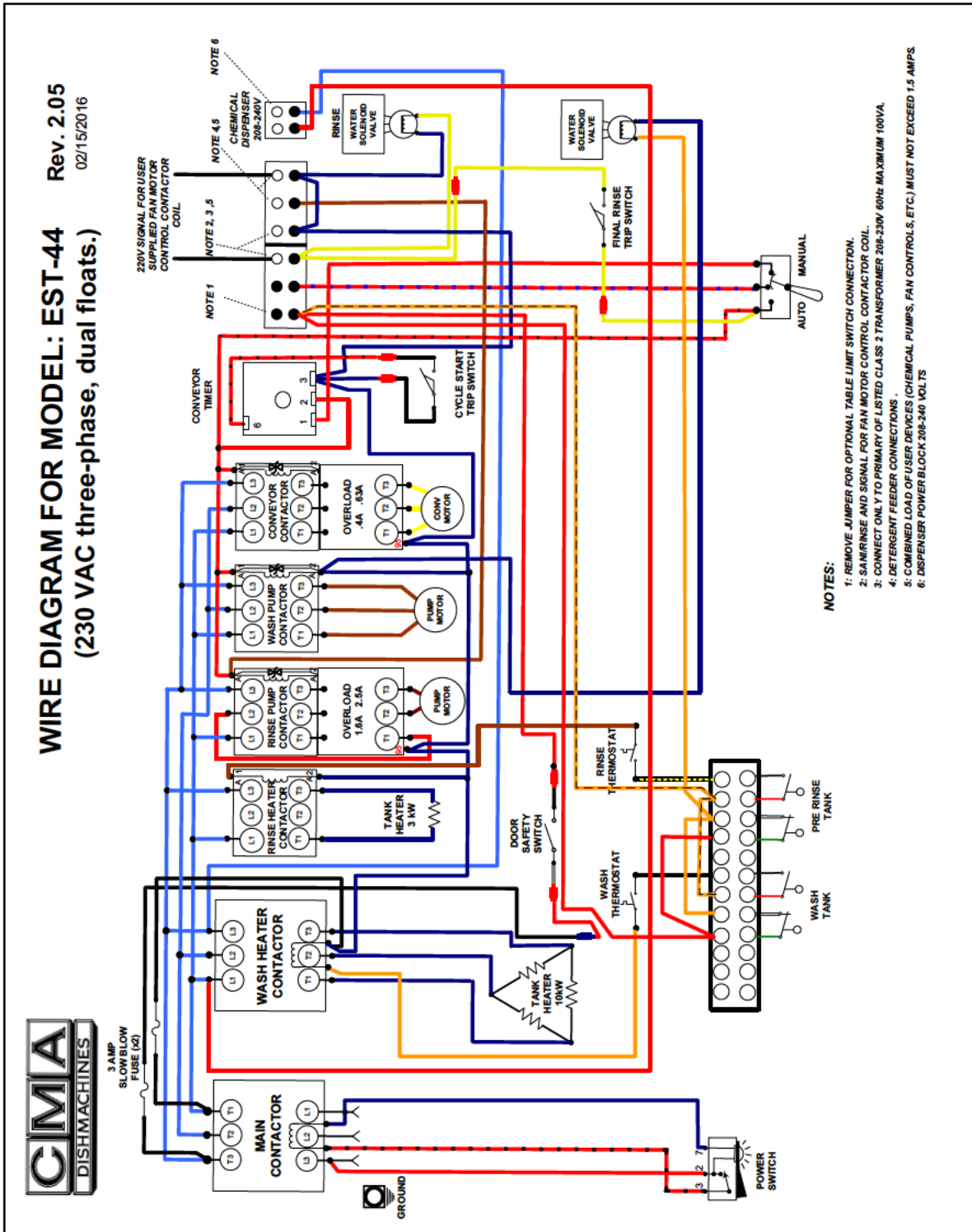

9. Electrical Diagram For E-Temp Heater Only

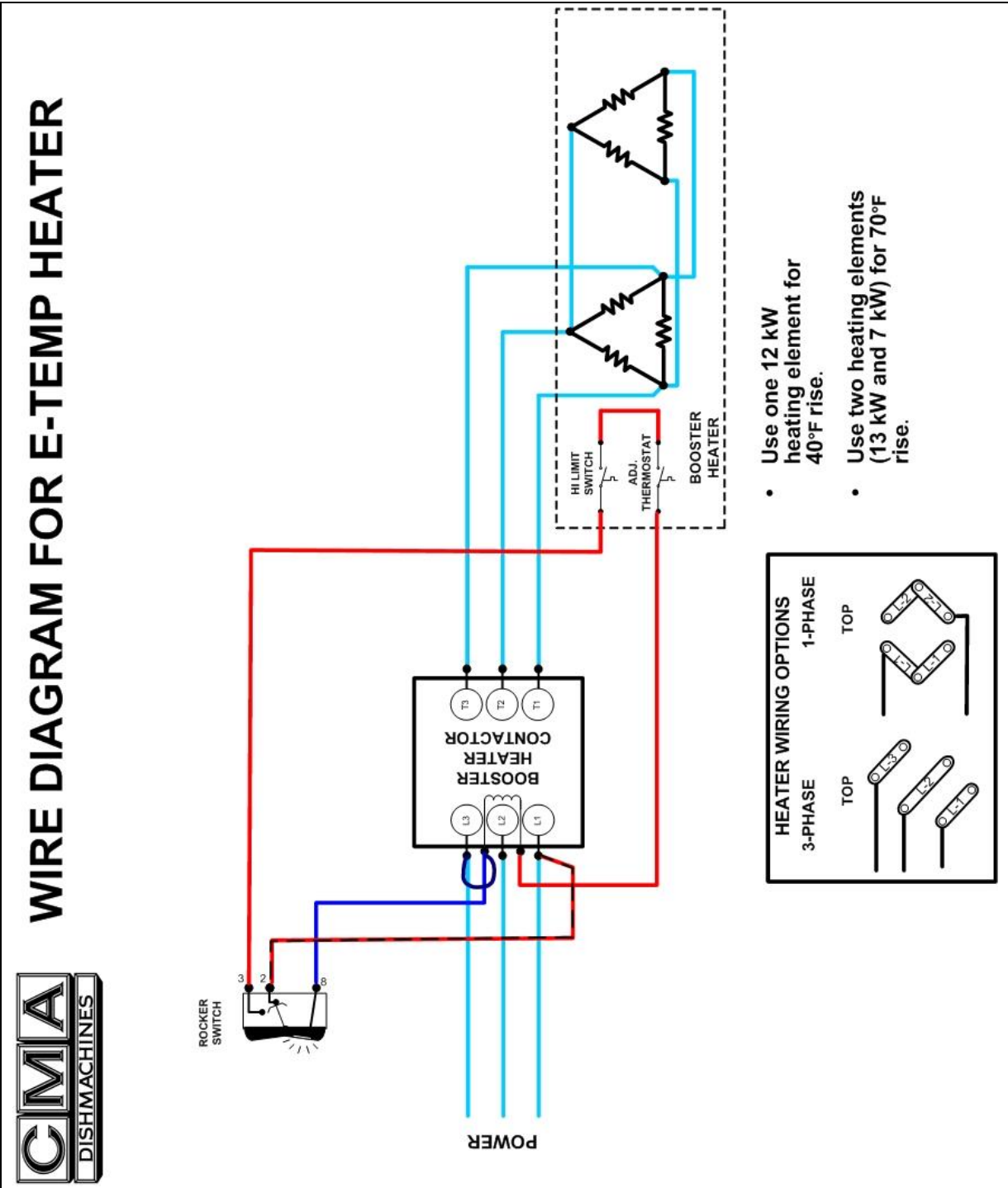

10. Electrical Diagram For 480V EST-44

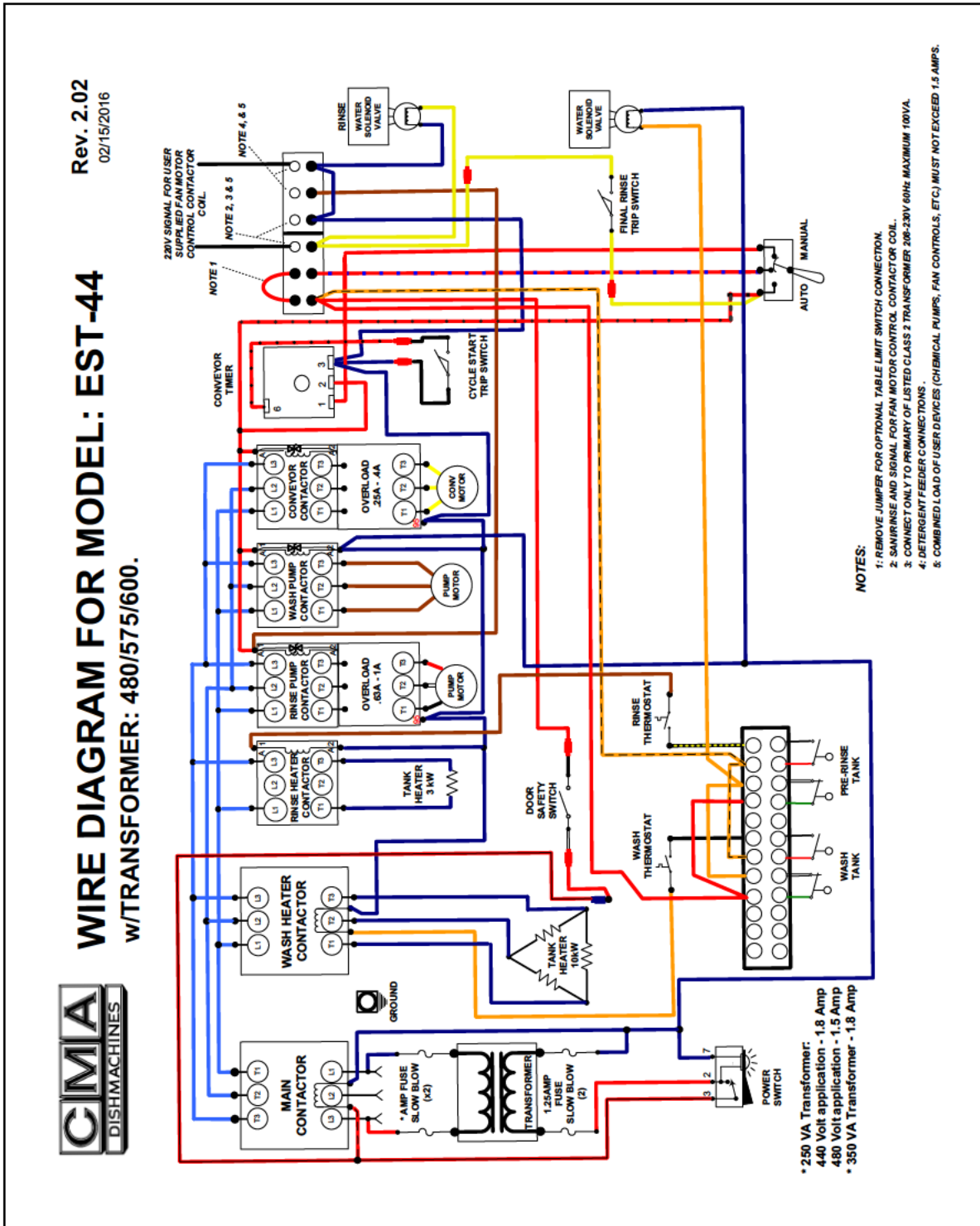

11. Electrical Diagram For 240V,1 phase EST-44

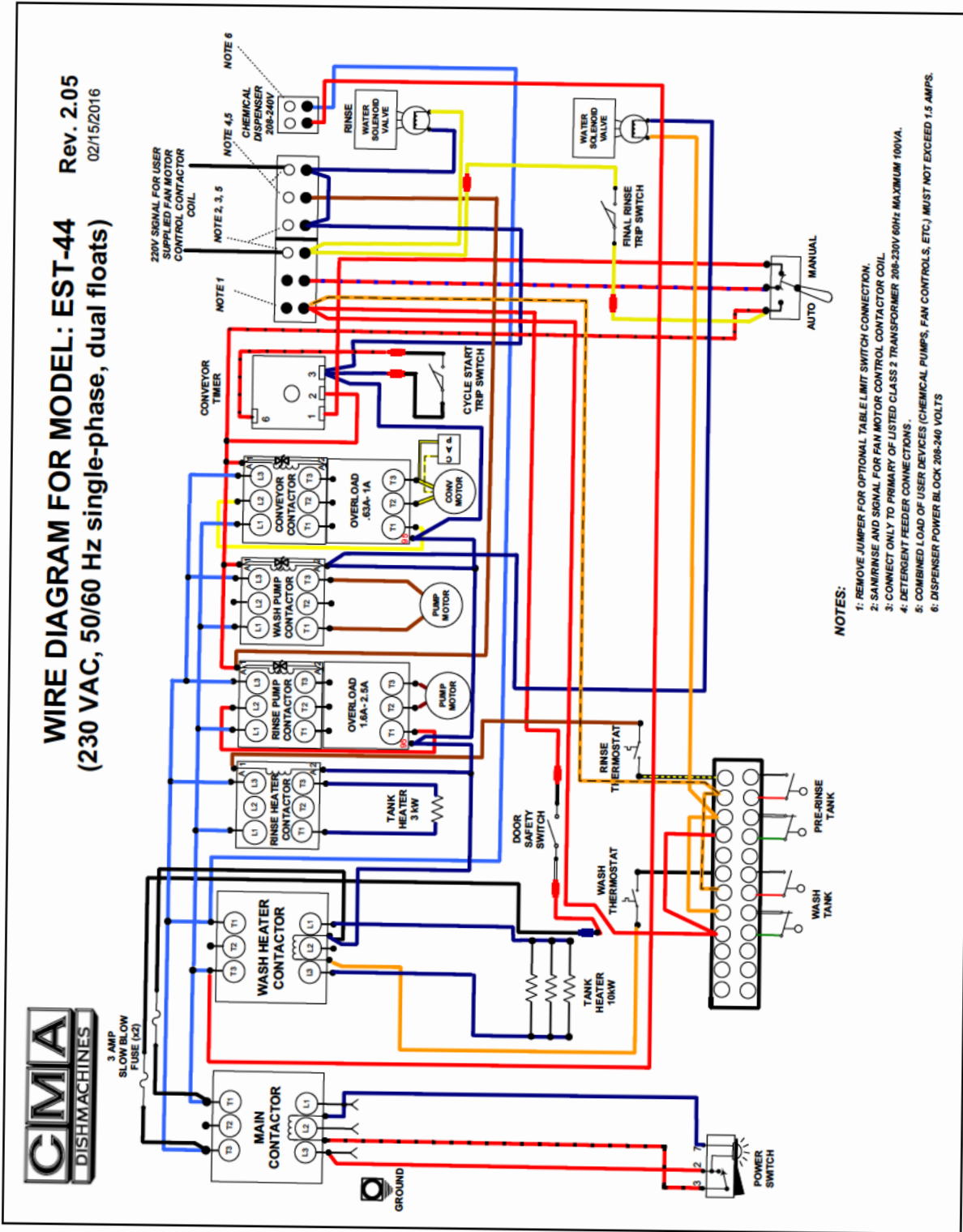



WIRE DIAGRAM FOR MODEL: EST-44

(230 VAC single-phase, dual floats)

Rev. 2.05
07/2023

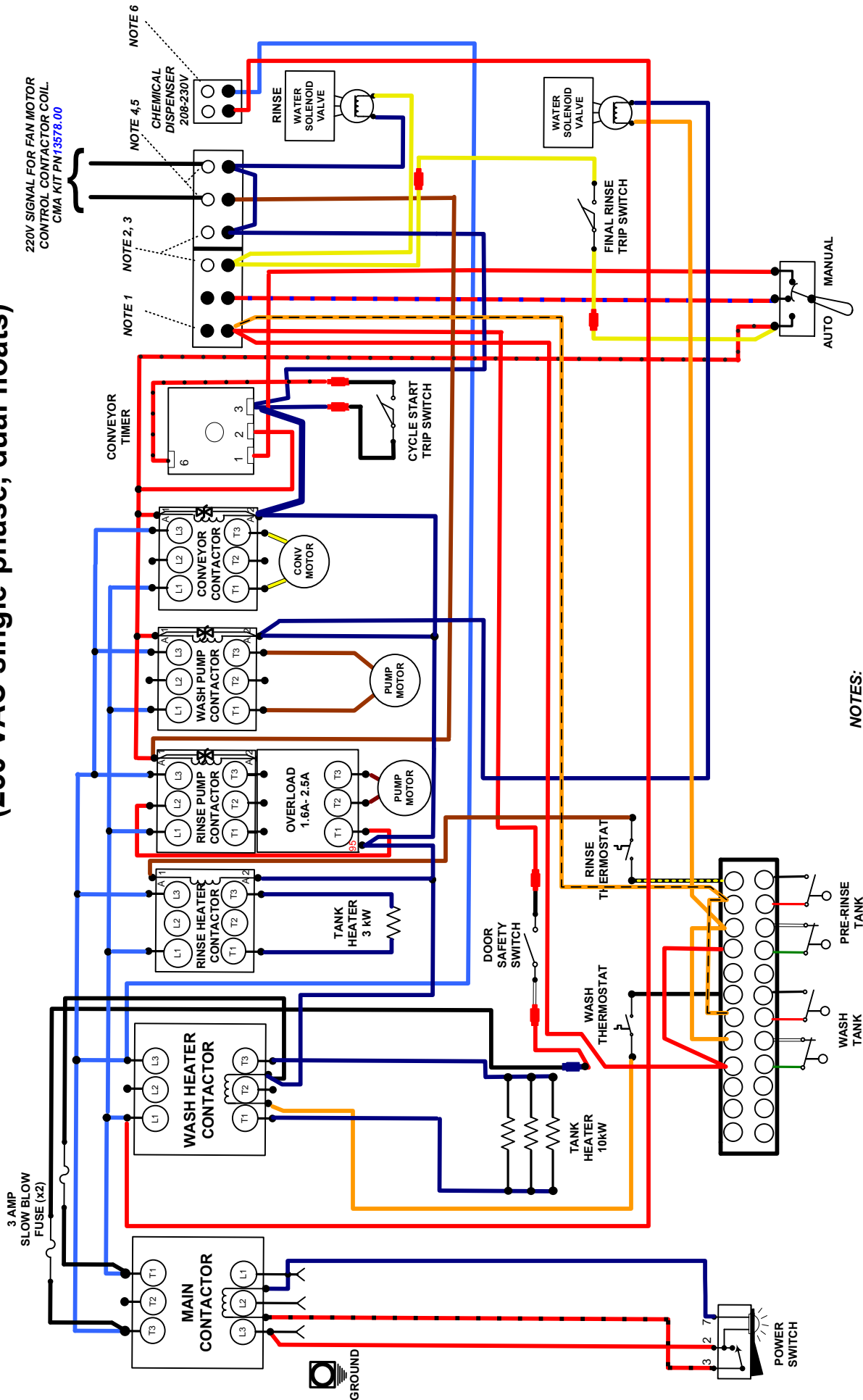

220V SIGNAL FOR FAN MOTOR
CONTROL CONTACTOR COIL
CIMA KIT PN13578.00

NOTES:

- 1: TABLE LIMIT SWITCH CONNECTION PRE-WIRED AT FACTORY.
- 2: SANI/RINSE. SIGNAL IS ON WHEN FINAL RINSE IS ACTIVE.
- 3: CONNECT ONLY TO PRIMARY OF LISTED CLASS 2 TRANSFORMER 208-230V 60HZ MAXIMUM 100VA.
- 4: DETERGENT FEEDER. SIGNAL AND FAN MOTOR CONTROL CONTACTOR COIL.
- 5: COMBINED LOAD OF USER DEVICES (CHEMICAL PUMPS, FAN CONTROLS, ETC.) MUST NOT EXCEED 1 AMP.
- 6: DISPENSER POWER BLOCK 208-240 VOLTS