

MODEL EST66

PARTS MANUAL

Rev.1.07
09-13-19



CMA DISHMACHINES
17707 VALLEY VIEW AVE
CERRITOS
CALIFORNIA 90703

800-854-6417
FAX 714-895-2141



www.cmadishmachines.com

[Buy Parts](#)

Table of Contents

EST-66

1.	PARTS MANUAL	4
1.1.	Initial Parts Kit	4
1.2.	Exploded View Drawings.....	5
1.2.1.	<i>Cabinet Assembly</i>	<i>5</i>
1.2.2.	<i>Control Box Assembly (3 Phase).....</i>	<i>6</i>
1.2.3.	<i>Control Box Assembly (1 Phase).....</i>	<i>7</i>
1.2.4.	<i>480V Control Box Assembly (480V machines only).....</i>	<i>8</i>
1.2.5.	<i>Curtain and Optional Vent System</i>	<i>9</i>
1.2.6.	<i>Old Wash Temperature Control System (Square Flange).....</i>	<i>10</i>
1.2.7.	<i>New Wash Temperature Control System (Triangular Flange).....</i>	<i>11</i>
1.2.8.	<i>Rinse Temperature Control System</i>	<i>12</i>
1.2.9.	<i>Wash Pump Assembly (3 Phase).....</i>	<i>13</i>
1.2.10.	<i>Wash Pump Assembly (1 Phase).....</i>	<i>14</i>
1.2.11.	<i>Power Rinse Pump Assembly.....</i>	<i>15</i>
1.2.12.	<i>Drain System Assembly.....</i>	<i>16</i>
1.2.13.	<i>Plumbing System Assembly (Auto-Fill)</i>	<i>17</i>
1.2.14.	<i>Plumbing System Assembly (Final Rinse).....</i>	<i>18</i>
1.2.15.	<i>Wash System Assembly</i>	<i>19</i>
1.2.16.	<i>Rocker Arm Assembly.....</i>	<i>20</i>
1.2.17.	<i>Start Switch and Rinse Switch Assembly (Effective May 2014).....</i>	<i>21</i>
1.2.17.1.	<i>Right-to-Left Assembly</i>	<i>21</i>
1.2.17.2.	<i>Left-to-Right Assembly</i>	<i>22</i>
1.2.18.	<i>Start Switch and Rinse Switch Assembly</i>	<i>23</i>
1.2.19.	<i>Door Switch Assembly (Effective August, 2014).....</i>	<i>24</i>
1.2.20.	<i>Optional E-Temp Heater (Effective September 1, 2018).....</i>	<i>25</i>
1.2.21.	<i>Optional E-Temp Heater</i>	<i>26</i>
1.2.22.	<i>Unique Parts For EST-66 Tall machines.....</i>	<i>27</i>
2.	TABLE LIMIT SWITCH (P/N 13469.20)	28
3.	DRAIN WATER TEMPERING KIT (OPTIONAL)	29 & 30

1. Parts Manual

1.1. Initial Parts Kit

P/N	DESCRIPTION	Qty
00120.02	Bi Metal Thermometer	1
00201.85	Pump Motor, 1HP, 3Ph, 60 Hz, 220V	1
00206.30	Pump Seal Kit	1
00208.21	Slip Joint Nut Friction Ring Plastic	1
00208.40	Slip Joint Nut Gasket	1
00421.83	Power Rocker Switch, Red	1
00562.00	Door Roller Switch	1
00631.05	Ice Cube Relay 220V 12Amp	1
00707.00	½" Water Solenoid Repair Kit JE	1
00738.15	Solenoid Coil JE 220V	1
03202.00	Thermometer (Capillary)	1
03226.00	Pump O-Ring Gasket	1
03623.00	½ Vac Breaker Repair Kit Watts	1
13003.17	Contactora, 60-Amp	1
13003.50	Contactora, 30-Amp	1
13003.70	Toggle Switch SPDT 20AMP	1
13012.26	Motor Contactora, 220V	1
13013.45	Conveyor Motor Overload Relay	1
13014.40	Power Rinse Overload Relay	1
13403.26	Fuse, 3-Amp/250V Slow Blow	2
13408.64	Table Limit Switch Bracket Spring	1
13415.47	Heater 3kW (GL-C & EST-66)	1
13417.92	Heater Thermostat	1
13418.60	Dip Switch Timer 230V	1
13422.83	Immersion Heater, 3Ph/1Ph, 208, 13kW	1
13427.10	Table Limit Switch	1
13465.00	Dual Float Switch, SS	1
13503.60	Power Rinse Pump - 1ph 208-240v 60HZ	1
13503.06	EST-44 Gear Motor Assy	1
13507.65	Cam Bearing Assy (New Dec 2007)	1
13508.70	Heavy Duty Clutch Spring	1

1.2. Exploded View Drawings

1.2.1. Cabinet Assembly

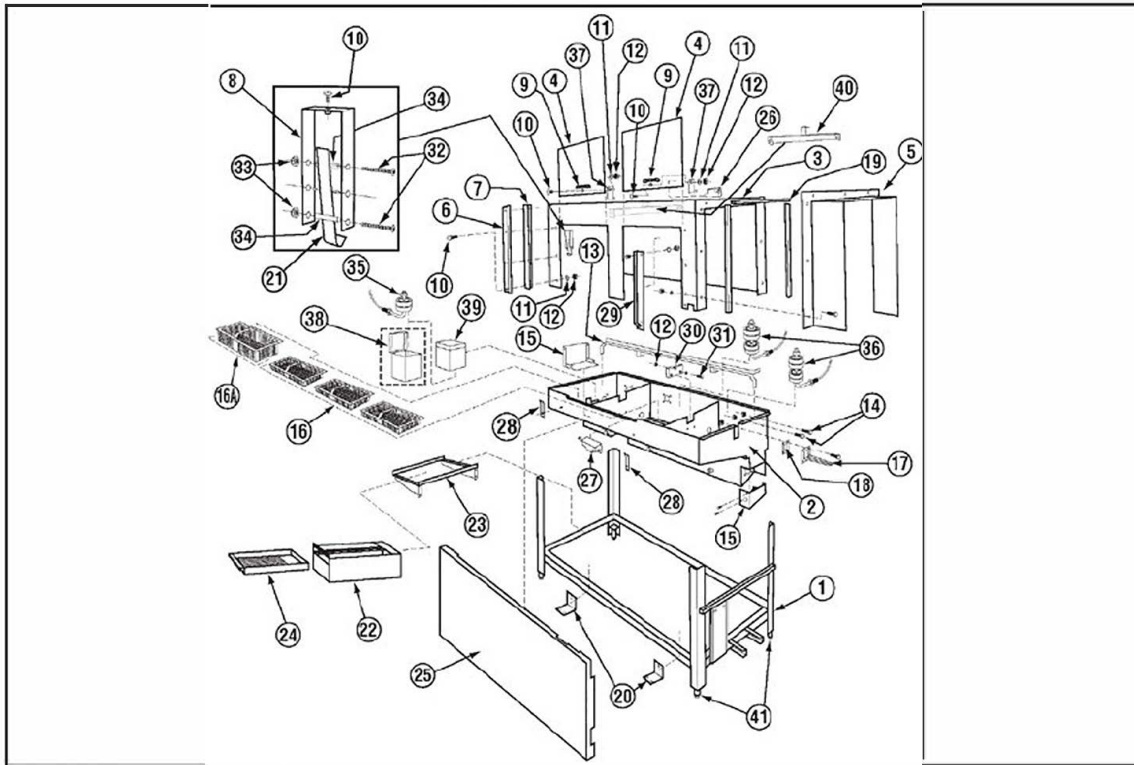

ITEM NO.	NO. REQ'D	P/N	DESCRIPTION
1	2	13949.22	CMA-66/EST Stand
2	2	13949.26	EST-66 Pan L>R
		13949.36	EST-66 Pan R>L
3	2	13949.09	EST-66 Wrapper L-R
		13949.19	EST-66 Wrapper R/L
4	2	01506.54	EST-66 Door R-L
		01506.54	EST-66 Door L-R
5	2	13901.10	Wrapper Shield
6	8	01554.30	Door Guide
7	8	00636.10	Door Guide Plastic
8	1	13915.60	Door Latch Bracket
9	2	00535.30	Door Handle
10	29	00905.00	1/4-20 x 1/2" Trusshead Bolt
11	62	00924.00	1/4" Washer, SS
12	54	00912.00	1/4-20 Nylon Lock Nut
13	2	13906.37	EST-66 Tray Track RH
		13906.39	EST-66 Tray Track LH
14	8	00914.10	1/4-20 x 5/8" Hex Head Bolt
		13939.50	EST-44 Heater Cover
16	3	13942.00	Strainer Basket, Wash/Rinse
16A	1	13942.20	Strainer Basket EST-66 (3" deep)
17	1	13913.10	Drip Chute
18	1	13542.10	Drip Chute Gasket

ITEM NO.	NO. REQ'D	P/N	DESCRIPTION
19	4	03705.00	Foam Tape
20	2	13010.06	Drain Valve Handle Support
21	2	13701.00	Door Latch
22	1	01579.10	Scrap Trap Body (Univ)
23	1	17579.20	EST Scrap Trap Holder
24	1	01579.20	Scrap Trap Drawer (Univ)
25	1	13912.36	CMA-66 Splash Shield
26	1	00556.60	Reed Switch Magnet -ISI
27	1	00556.10	Reed Switch-ISI
28	2	13912.81	Splash Shield Clip
29	1	13704.08	L-R Curtain Splash Shield
30	1	13704.06	R-L Curtain Splash Shield
31	2	13522.10	Conveyor Bar Guide
		00962.00	1/4-20 X 1 SS Hexhead Bolt
32	4	00960.00	8-32x1-1/2" Panhead Screw
33	2	00927.00	8-32 Nylon Lock Nut
34	4	13915.30	Door Latch Bracket Spacer
35	1	13465.30	Bent Stem Single Float Switch
36	1	13465.00	EST-44/66 Dual Float Switch
37	1	13701.30	Door Stop Bracket
38	1	13943.00	Float Switch Box
39	1	13946.00	Float Switch Box (comes with # 13946.50)
40	1	13949.10	EST-44/66 Wrapper Brace
41	4	01310.30	Adjustable Foot w/SS Toe

1.2.2. Control Box Assembly (3 Phase)

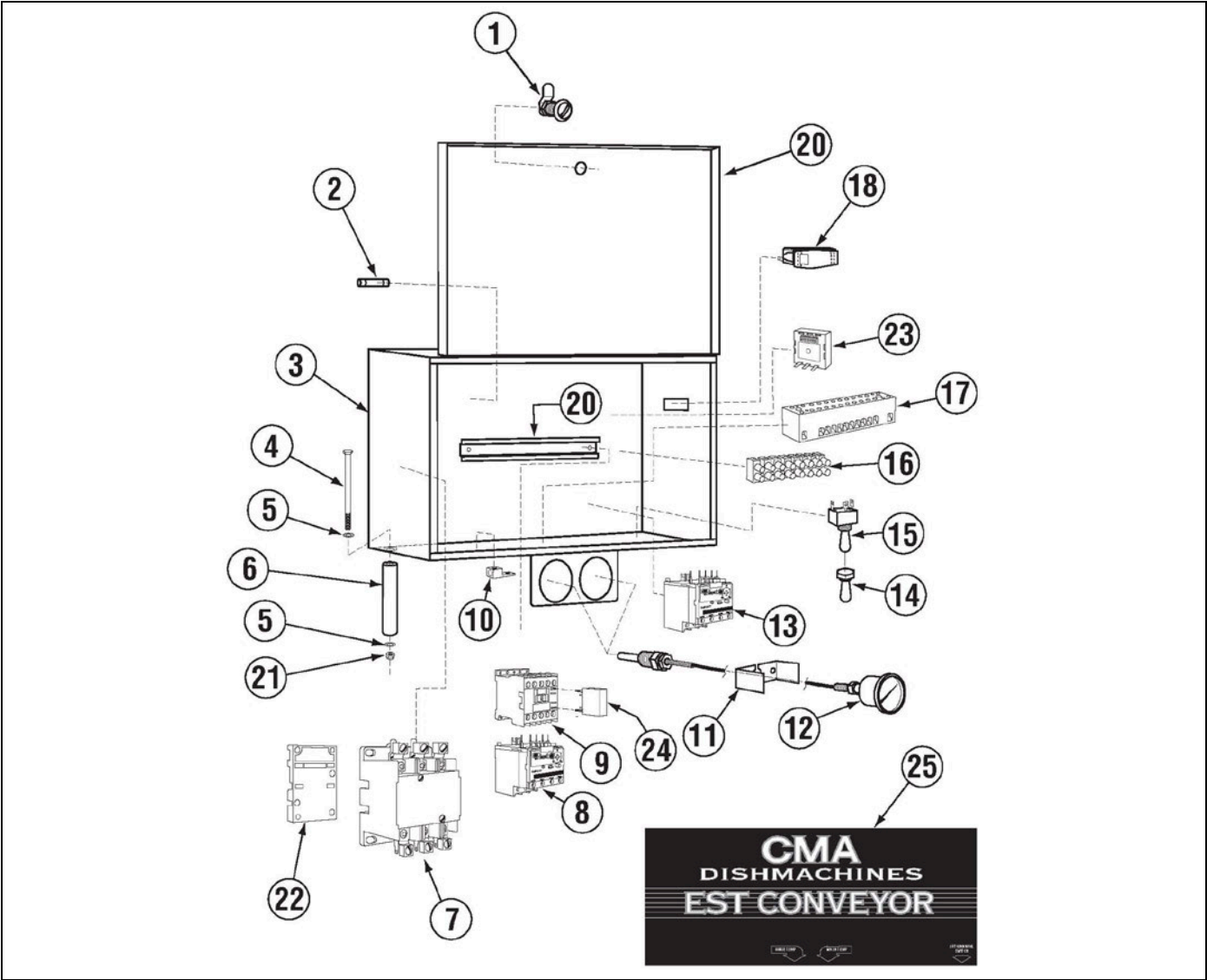

ITEM NO.	NO. REQ'D	P/N	DESCRIPTION
1	1	00449.50	Lock, Keyless
2	2	13403.26	Fuse, 3-Amp/250V Slow Blow
3	1	13941.12	EST-44 Control Box Body
4	4	00909.00	¼-20x3 ¼ SS Hexhead Bolt
5	8	00924.00	¼ SS Washer
6	4	13941.20	EST-44 Control Box Legs
7	2	13003.17	Contacteur 60 Amp 3 Pole
8	1	13013.45	Overload Relay 0.4 to 0.63 Conveyor
9	5	13012.26	Motor Contactor, 220V
10	1	13426.50	Ground Block
11	2	03202.08	Thermometer Bracket
12	2	03202.00	Thermometer
13	1	13014.40	Overload Relay 1.6 to 2.5 Power Rinse

ITEM NO.	NO. REQ'D	P/N	DESCRIPTION
14	1	00470.10	Toggle Switch Rubber Boot
15	1	13003.70	Toggle Switch SPDT 20AMP
16	1	00454.20	8-Pole Terminal Block
17	1	15520.00	Power Block 12-Position
18	1	00421.83	Power Rocker Switch, Red
19	1	13003.60	Starter DIN Rail
20	1	13941.22	EST-44 Control box lid
21	4	00912.00	¼-20 Nylon Lock Nut
22	2	13003.62	Din Rail Mounting Bracket
23	1	13418.60	Dip Switch Timer 230 V
24	4	13012.29	Surge Absorber
25	1	06232.20	EST Conveyor Label Full Size label

1.2.3. Control Box Assembly (1 Phase)

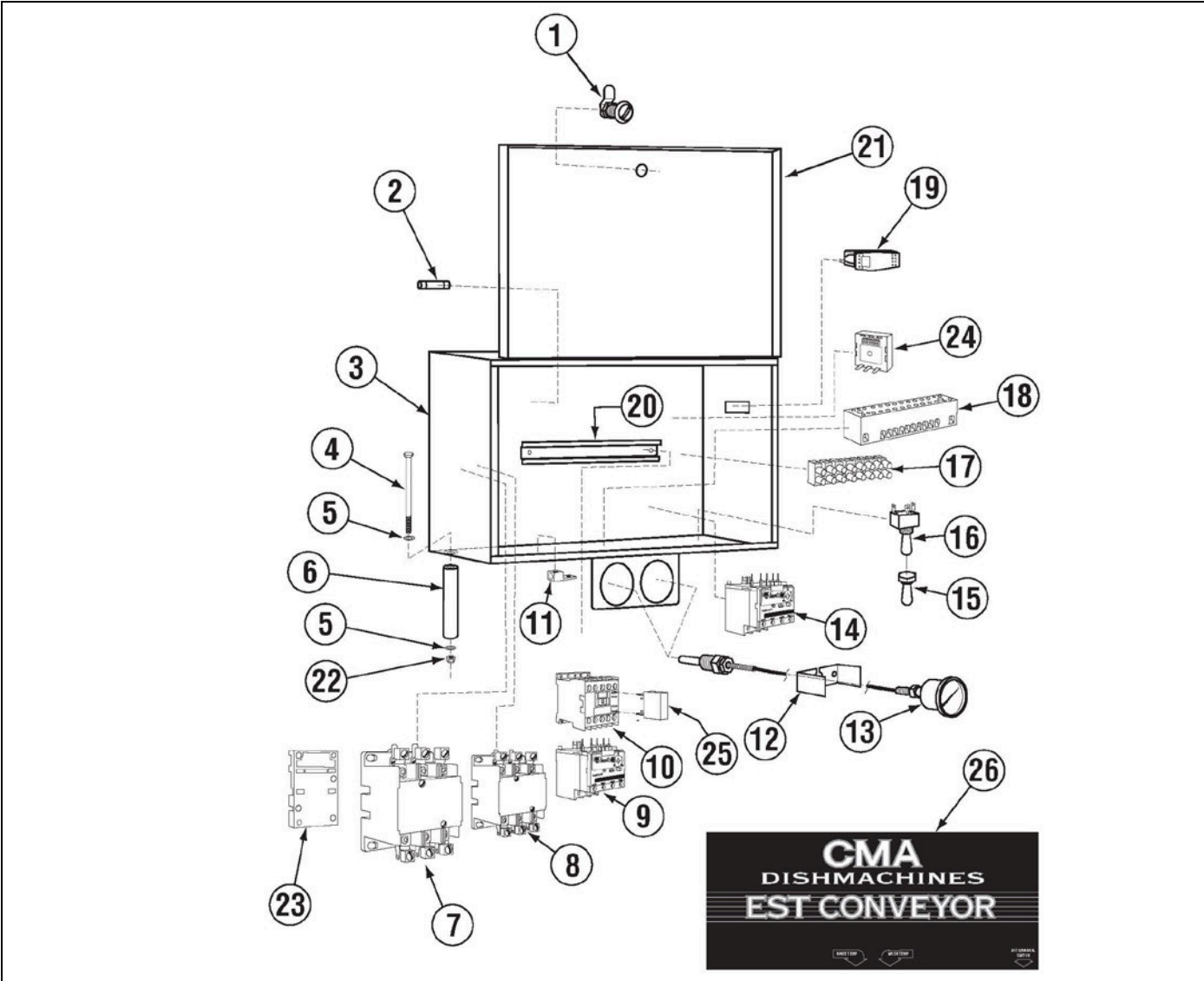

ITEM NO.	NO. REQ'D	P/N	DESCRIPTION
1	1	00449.50	Lock, Keyless
2	2	13403.26	Fuse, 3-Amp/250V Slow Blow
3	1	13941.12	EST-44 Control Box Body
4	4	00909.00	¼-20x3 ¼ SS Hexhead Bolt
5	8	00924.00	¼ SS Washer
6	4	13941.20	EST-44 Control Box Legs
7	1	13003.18	Contacteur 75 Amp 3 Pole
8	1	13003.17	Contacteur 60 Amp 3 Pole
9	1	13014.48	Overload Relay 0.63 to 1.0 Conveyor
10	5	13012.26	Motor Contactor, 220V
11	1	13426.50	Ground Block
12	2	03202.08	Thermometer Bracket
13	2	03202.00	Thermometer

ITEM NO.	NO. REQ'D	P/N	DESCRIPTION
14	1	13014.40	Overload Relay 1.6 to 2.5 Power Rinse
15	1	00470.10	Toggle Switch Rubber Boot
16	1	13003.70	Toggle Switch SPDT 20AMP
17	1	00454.20	8-Pole Terminal Block
18	1	15520.00	Power Block 12-Position
19	1	00421.83	Power Rocker Switch, Red
20	1	13003.60	Starter DIN Rail
21	1	13941.22	EST-44 Control box lid
22	4	00912.00	¼-20 Nylon Lock Nut
23	2	13003.62	Din Rail Mounting Bracket
24	1	13418.60	Dip Switch Timer 230 V
25	4	13012.29	Surge Absorber
26	1	06232.20	EST Conveyor Label Full Size label

1.2.4. 480V Control Box Assembly (480V machines only)

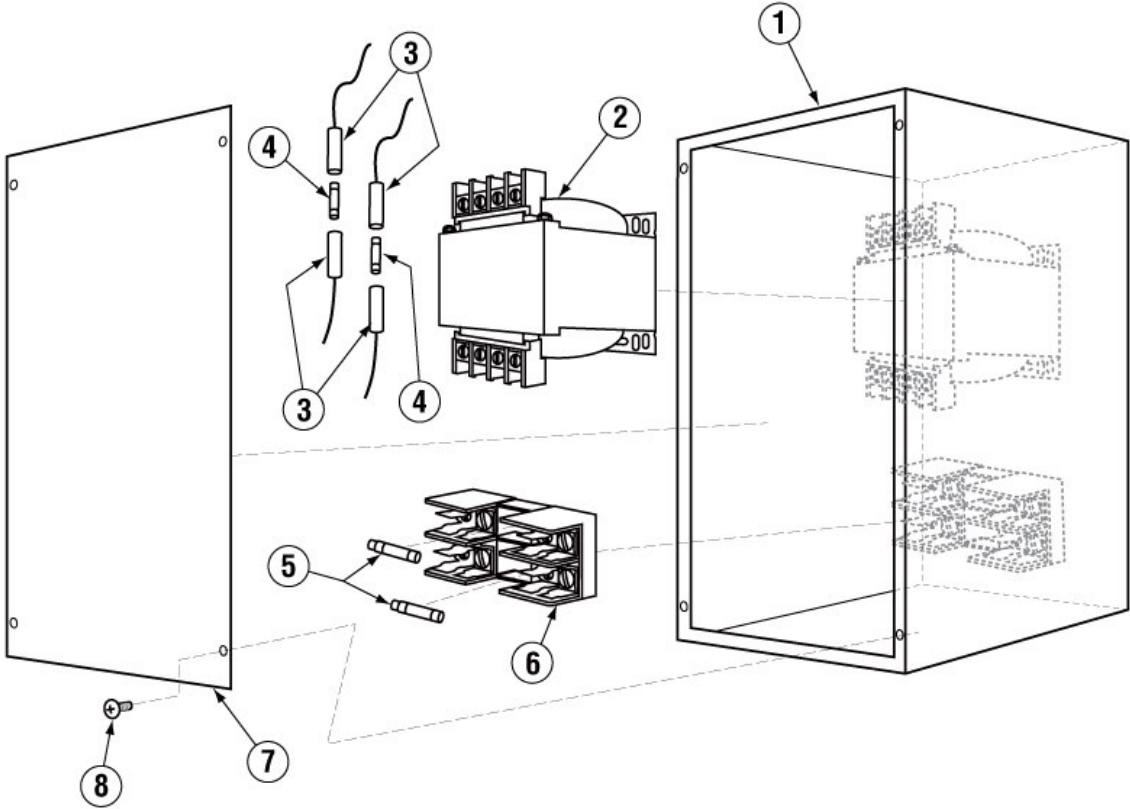

ITEM NO.	NO. REQ'D	P/N	DESCRIPTION
1	1	13905.13	Transformer Box
2	1	13423.82	Transformer 480V - 240V
3	2	13403.21	Fuse Holder - Inline
4	2	13403.40	Fuse 1.25 Amp 230V Slow Blow
5	2	13402.10	Fuse 1.50 Amp 600V Slow Blow
6	1	13420.10	Fuse Clip 2-Poll, Pressure Plate
7	1	13905.23	Transformer Box Lid
8	4	00940.50	10-32 X 3/8 Truss Head Screw

1.2.5. Curtain and Optional Vent System

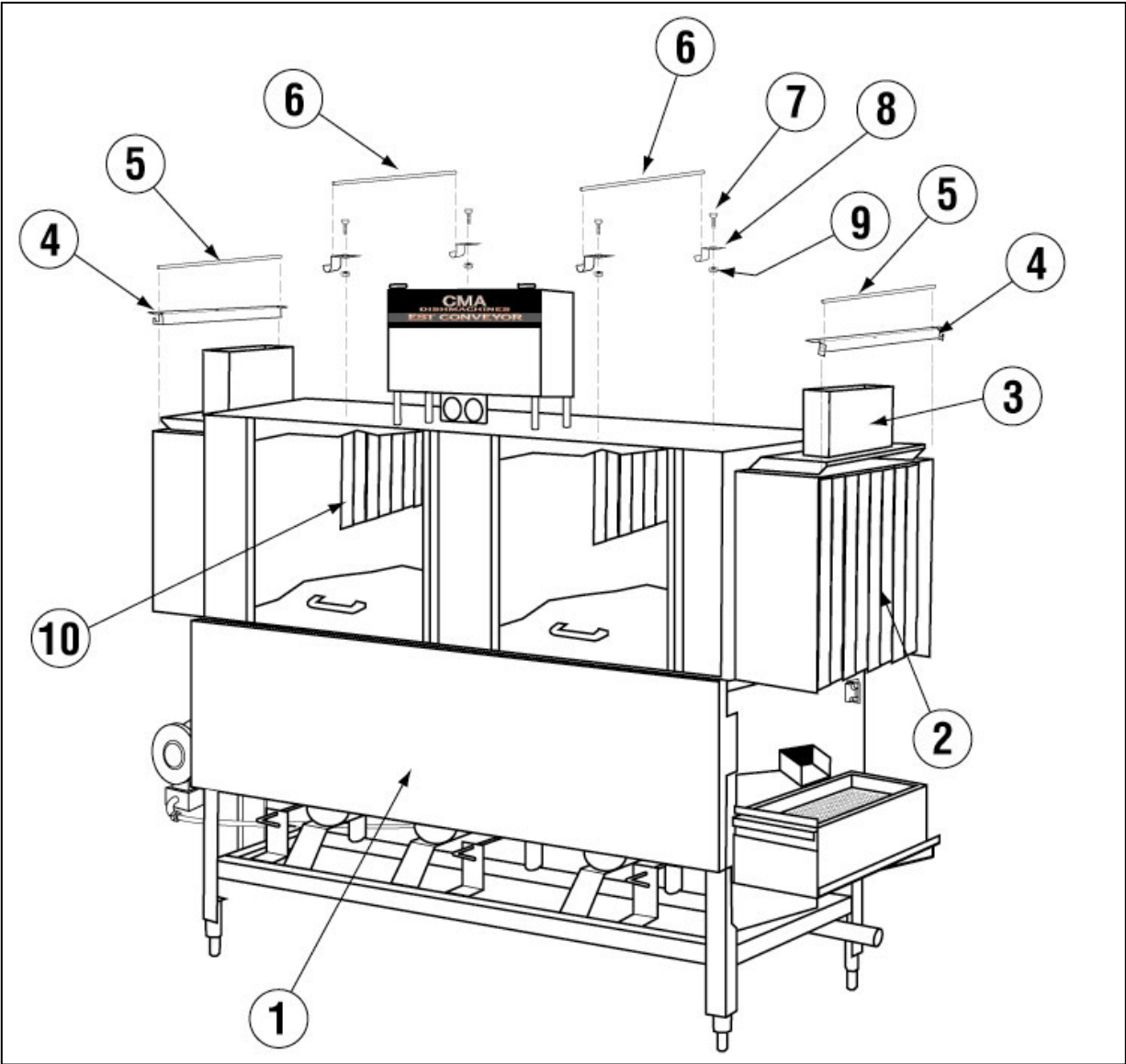

ITEM NO.	NO. REQ'D	P/N	DESCRIPTION
1	1	13912.36	CMA-66 Splash Shield
2	2	13702.25	Curtain CMA-44(20-5/8" x 15")
3	1	13901.82	Hood Adapter EST-44 (2 pc set)
4	2	13901.30	Outer Wrap Shield Curtain Support
5	2	13705.00	Curtain Rod Short

ITEM NO.	NO. REQ'D	P/N	DESCRIPTION
6	2	13705.10	Curtain Rod Long
7	4	00914.10	1/4-20 X 5/8 Hexhead Bolt
8	2	13901.12	CMA 44 Wash Curtain Support ('07)
9	4	00912.00	1/4-20 Nylon Lock Nut
10	2	13702.35	Curtain CMA-44 (24 5/8" x 11-1/2")

1.2.6. Old Wash Temperature Control System (Square Flange)

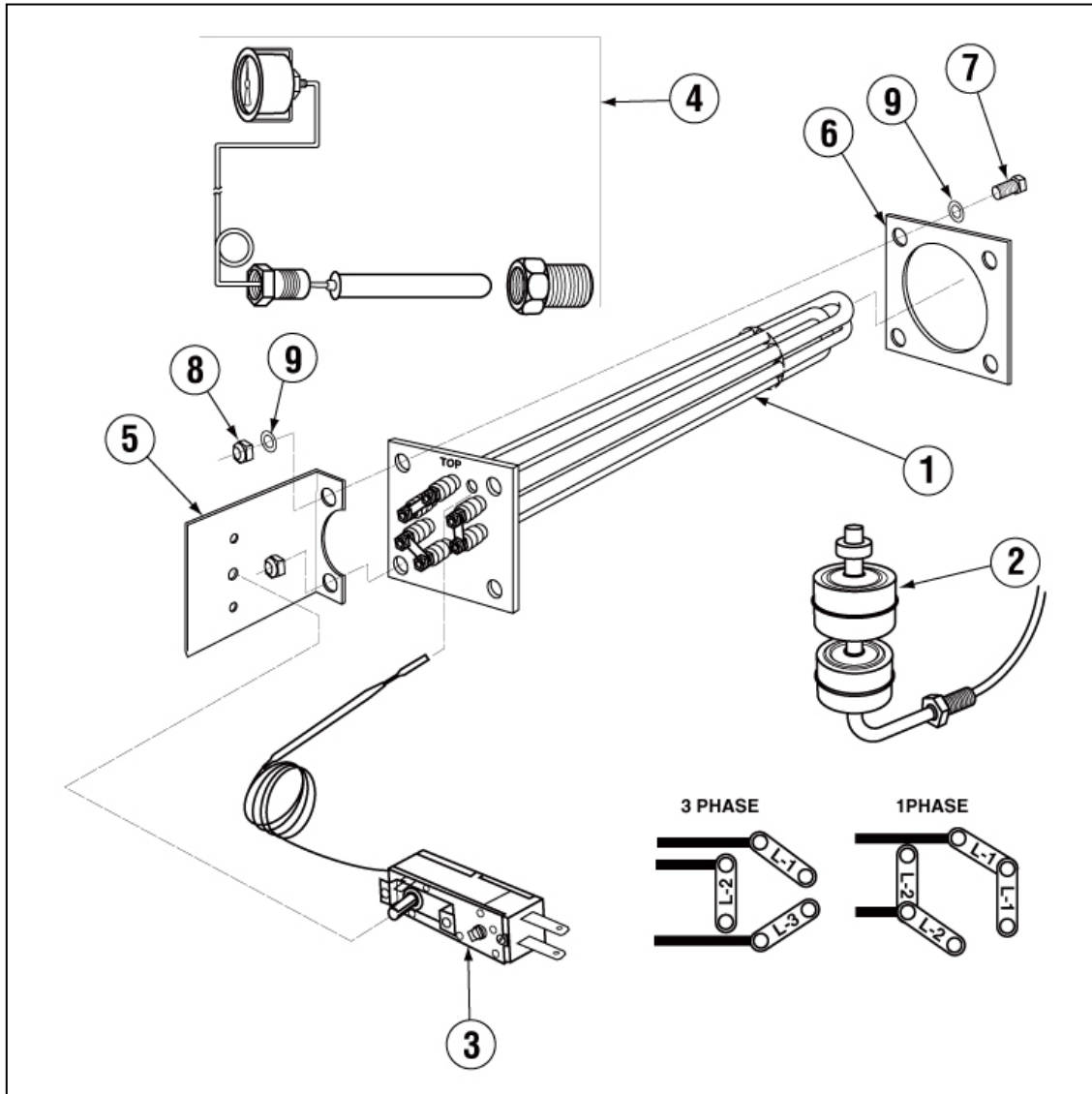

ITEM NO.	NO. REQ'D	P/N	DESCRIPTION
1	1	13417.75	Immersion Heater 3hp/1PH 380V 10kW
	1	13417.80	Immersion Heater 3Ph/1PH 240V 10kW
2	1	13465.00	EST-44/66 Dual Float Switch
3	1	13417.92	Heater Thermostat (EGO)
4	1	03202.00	Thermometer

ITEM NO.	NO. REQ'D	P/N	DESCRIPTION
5	1	13416.10	Thermostat Bracket
6	1	13417.45	Heater Gasket
7	4	00901.00	5/16 - 18 x 1" Hexhead Bolt
8	4	13805.00	5/16 - 18 Nylon Nut
9	8	00926.00	5/16" SS washer

Parts Manual

1.2.7. New Wash Temperature Control System (Triangular Flange)

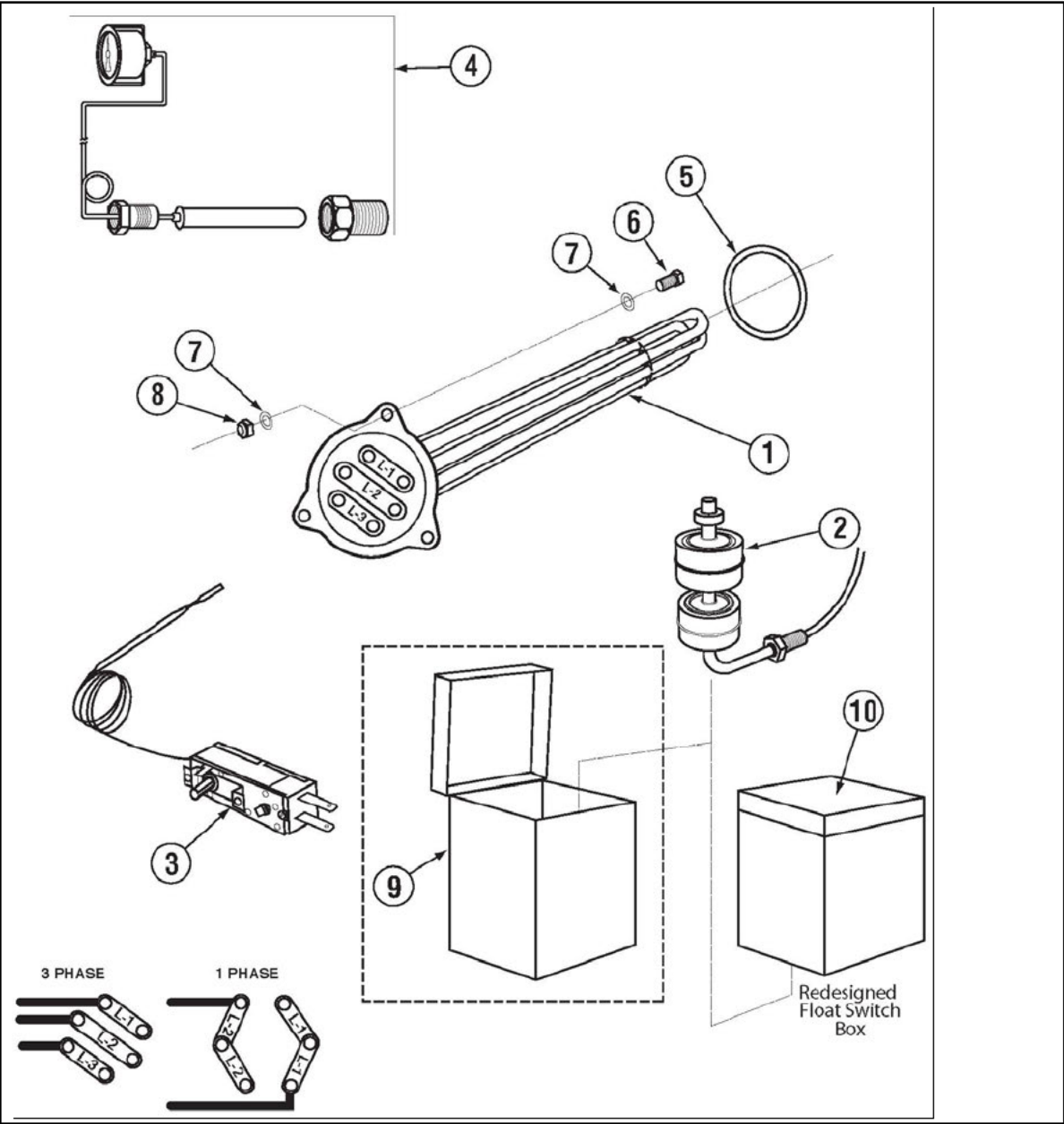

ITEM NO.	NO. REQ'D	P/N	DESCRIPTION
1	1	13422.75	480V 12KW Triangular Immersion Htr.
	1	13422.80	208V 10KW Triangular Immersion Htr.*
	1	13422.83	208V 13KW Triangular Immersion Htr.**
2	1	13465.00	EST-44/66 Dual Float Switch
3	1	13417.92	Thermostat (EGO)
4	1	03202.00	Thermometer

ITEM NO.	NO. REQ'D	P/N	DESCRIPTION
5	1	15518.11	Heater Gasket
6	4	00914.00	1/4-20 X 3/4 Hexhead Bolt
7	8	00924.00	1/4" SS washer
8	4	00912.00	1/4-20 Nylon Lock Nut
9	1	13943.00	Float Switch Box
10	1	13946.00	Float Switch Box (comes with # 13946.50)

* For single phase machines ** For three phase machines.

1.2.8. Rinse Temperature Control System

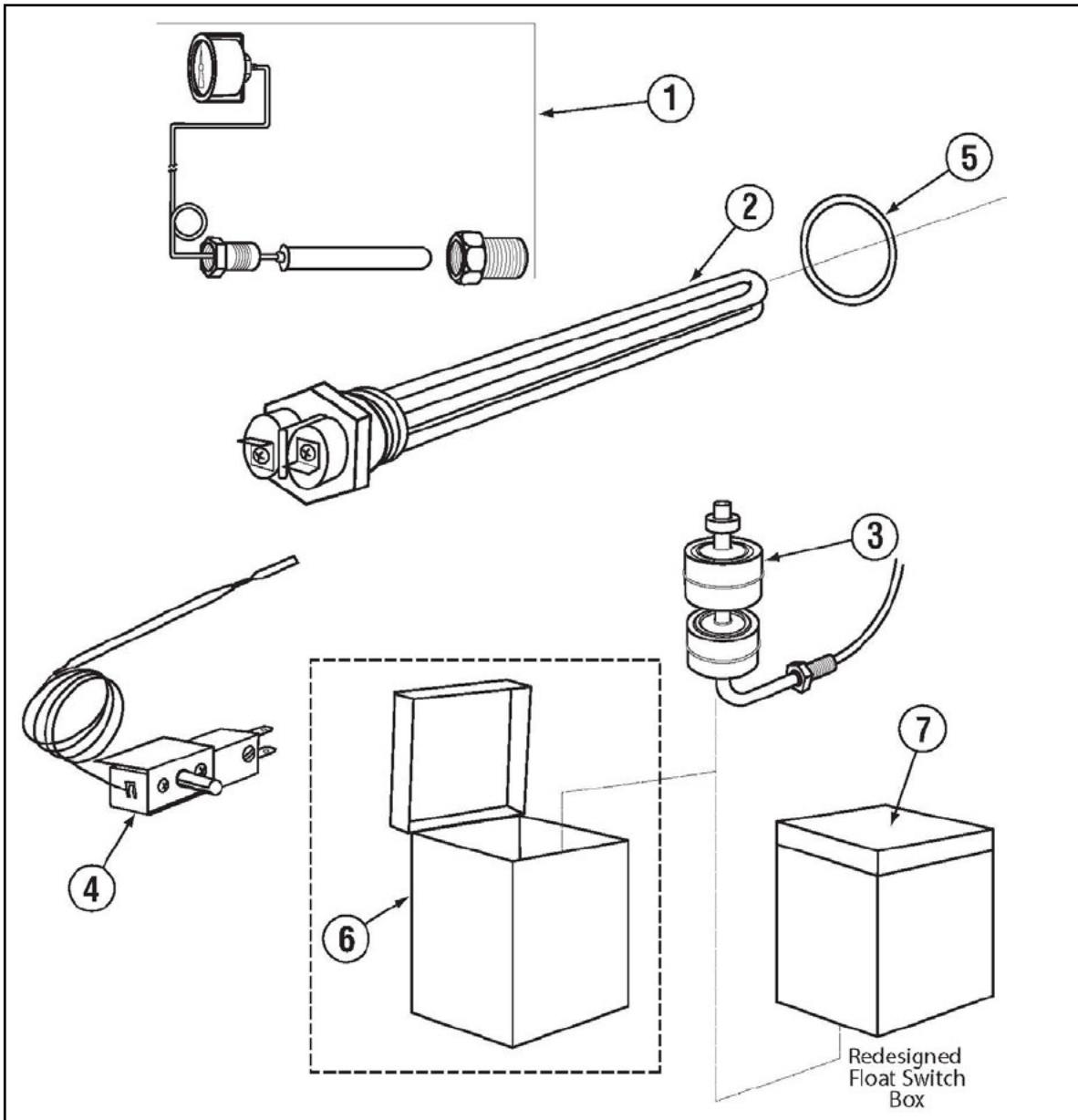

ITEM NO.	NO. REQ'D	P/N	DESCRIPTION
1	1	03202.00	Thermometer
2	1	13415.47 13955.00	Heater 3kW (GL-C & EST-66) Immersion Heater 3kW 480V
3	1	13465.00	Float Switch
4	1	13417.92	EST-66 Heater Thermostat (EGO)
5	1	00703.00	O-Ring Gasket
6	1	13943.00	Float Switch Box
7	1	13946.00	Float Switch Box (comes with # 13946.50)

1.2.9. Wash Pump Assembly (3 Phase)

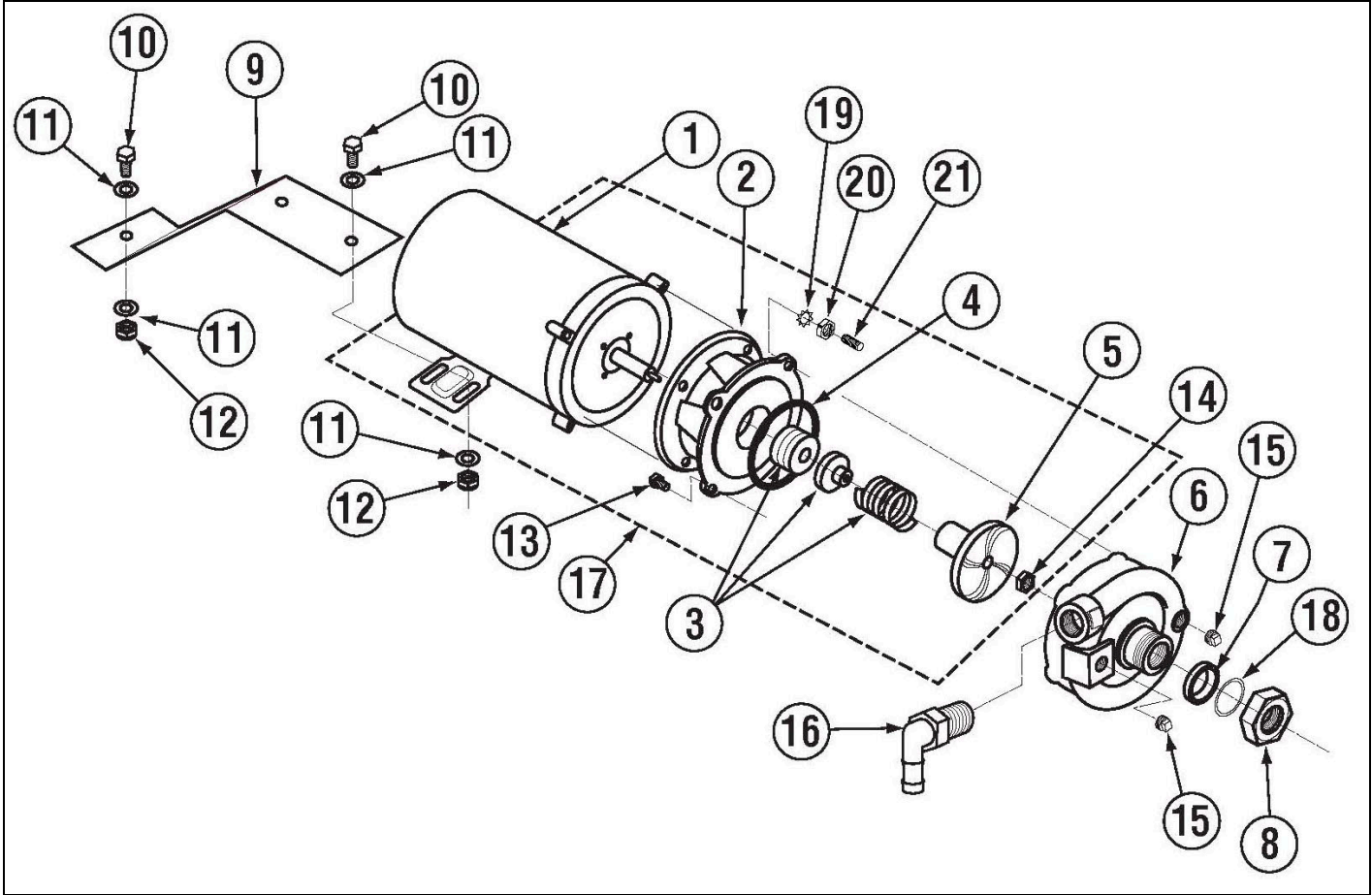

ITEM NO.	NO. REQ'D	P/N	DESCRIPTION
1	1	00201.85	Pump Motor, 1HP, 60 Hz, 220/460V
2	1	04207.10	Pump Base Mount
3	1	00206.30	Pump Seal Kit New
4	1	03226.00	Pump O-Ring Gasket
5	1	03222.10	Impeller (Open) SS
6	1	04207.20	Pump Cover
7	1	00208.40	Slip Joint Nut Gasket
8	1	00207.00	Compression Nut, 2.5"
9	1	13916.40	Motor Support Bracket
10	3	00906.00	1/4-20 x 1/2" Hex Bolt
11	6	00922.00	1/4" Lock Star Washer

ITEM NO.	NO. REQ'D	P/N	DESCRIPTION
12	3	00912.00	1/4-20 Nylon Lock Nut
13	8	00921.00	3/8-16 x 3/4" SS Hex Head Bolt
14	1	13829.00	7/16-20 Thin Nylon Lock Nut
15	2	00238.00	3/8" Male Plug
16	1	04604.00	^35 Deg Elbow MIP X Barb SS
17	1	00200.85	Pump Assembly, 1HP, 3Ph, 220V, 60 Hz*
18	1	00208.21	Slip Joint Nut Friction Ring
19	2	03807.50	3/8 External Lock Star Washer
20	2	03810.00	3/8-16 Thin Nut
21	2	00975.00	3/8"-16 x 1 1/2" SS Stud

*Includes Items 1, 2, 3, 4, 5 and 14.

Parts Manual

1.2.10. Wash Pump Assembly (1 Phase)

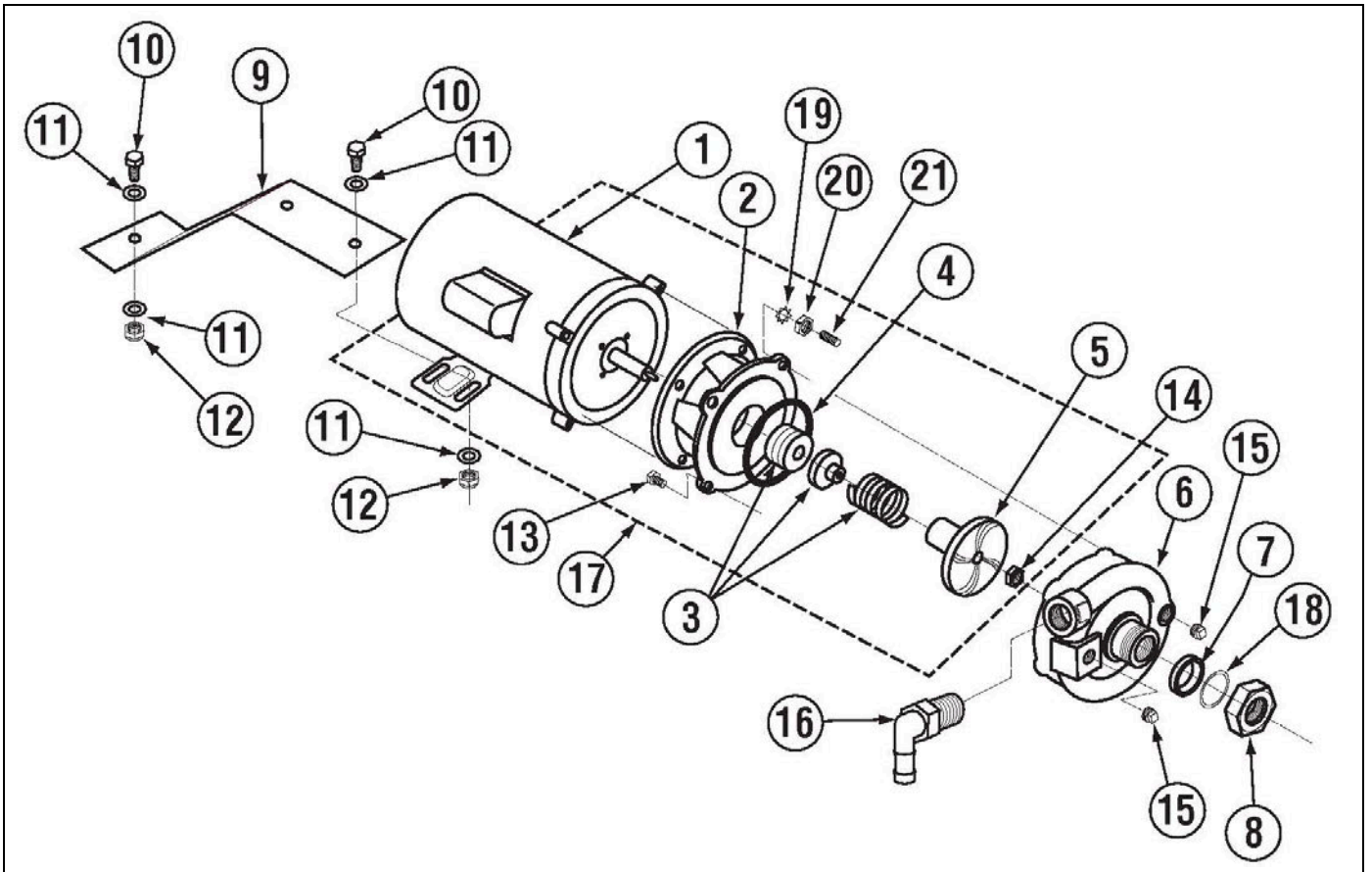

ITEM NO.	NO. REQ'D	P/N	DESCRIPTION
1	1	00201.00	Pump Motor 1 Hp,115/220V ,60Hz
2	1	04207.10	Pump Base Mount
3	1	00206.30	Pump Seal Kit New
4	1	03226.00	Pump O-Ring Gasket
5	1	03222.10	Impeller (Open) SS
6	1	04207.20	Pump Cover
7	1	00208.40	Slip Joint Nut Gasket
8	1	00207.00	Compression Nut, 2.5"
9	1	13916.40	Motor Support Bracket
10	3	00906.00	1/4-20 x 1/2" Hex Bolt
11	6	00922.00	1/4" Lock Star Washer

ITEM NO.	NO. REQ'D	P/N	DESCRIPTION
12	3	00912.00	1/4-20 Nylon Lock Nut
13	8	00921.00	3/8-16 x 3/4" SS Hex Head Bolt
14	1	13829.00	7/16-20 Thin Nylon Lock Nut
15	2	00238.00	3/8" Male Plug
16	1	04604.00	^35 Deg Elbow MIP X Barb SS
17	1	00201.10	Pump Assy 115/220V ,60Hz*
18	1	00208.21	Slip Joint Nut Friction Ring
19	2	03807.50	3/8 External Lock Star Washer
20	2	03810.00	3/8-16 Thin Nut
21	2	00975.00	3/8"-16 x 1 1/2" SS Stud

*Includes Items 1, 2, 3, 4, 5 and 14.

Parts Manual

1.2.11. Power Rinse Pump Assembly

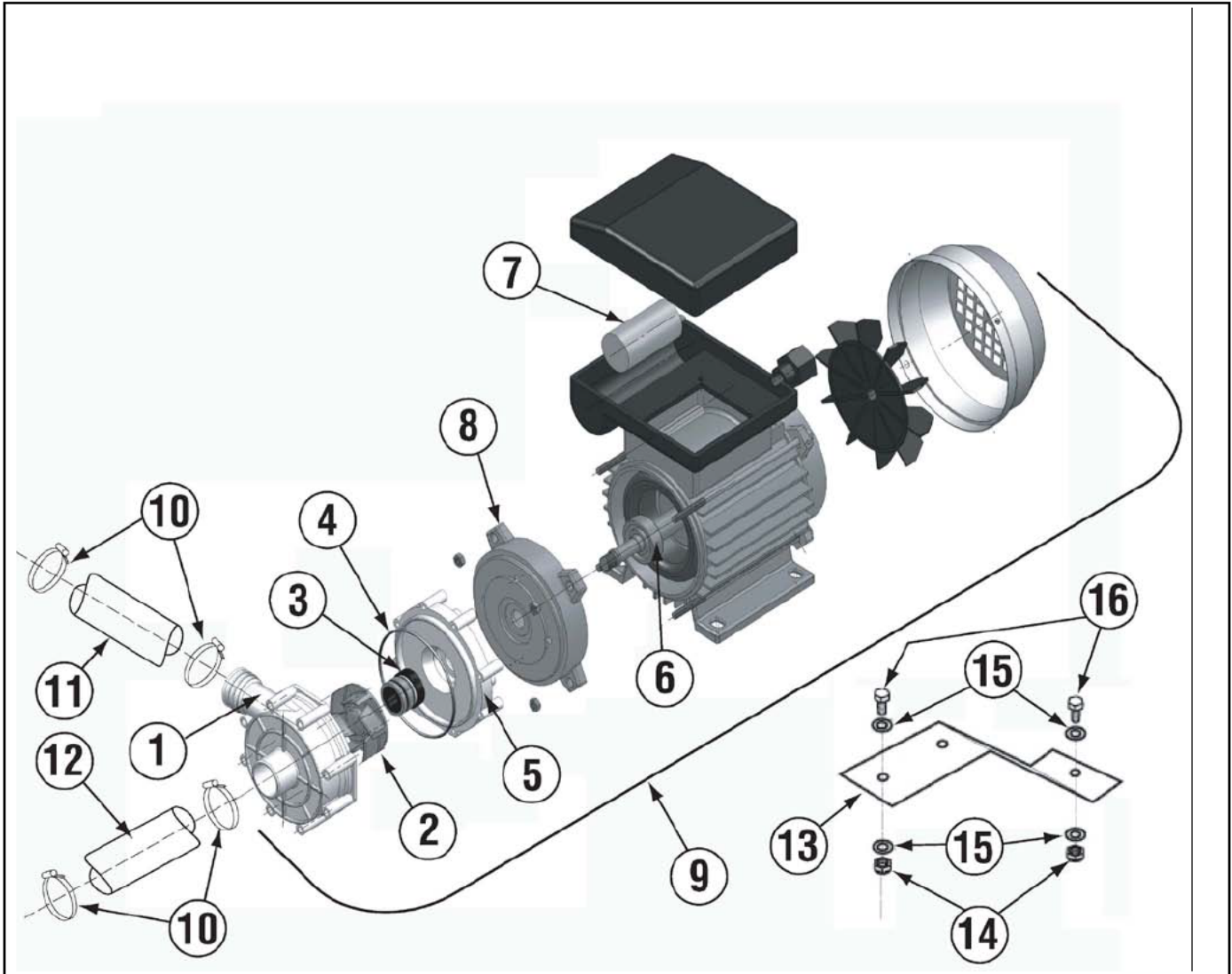

ITEM NO.	NO. REQ'D	P/N	DESCRIPTION
1	1	13503.70	Pump Head
2	1	13503.71	Impeller
3	1	13503.72	Seal Kit
4	1	13503.73	Pump O-Ring
5	1	13503.74	Back Plate
6	1	13503.75	Motor
7	1	13503.76	Capacitor
8	1	13503.77	Cover

ITEM NO.	NO. REQ'D	P/N	DESCRIPTION
9	1	13503.60 13503.80	Olympia Pump - 1ph 208-240v 60HZ Olympia Pump - 3ph 480v, 60HZ
10	4	03101.00	Hose Clamp # 16 1"
11	1	03108.66	Transfer Hose 1" - 35"
12	1	03108.65	Transfer Hose 1" - 3-1/2"
13	1	13916.45	EST-44 Final Rinse Motor Bracket
14	3	00906.00	1/4-20x1/2" Hex Bolt
15	6	00922.00	1/4-20 Lock Star Washer
16	3	00912.00	1/4-20 Nylon Nut

1.2.12. Drain System Assembly

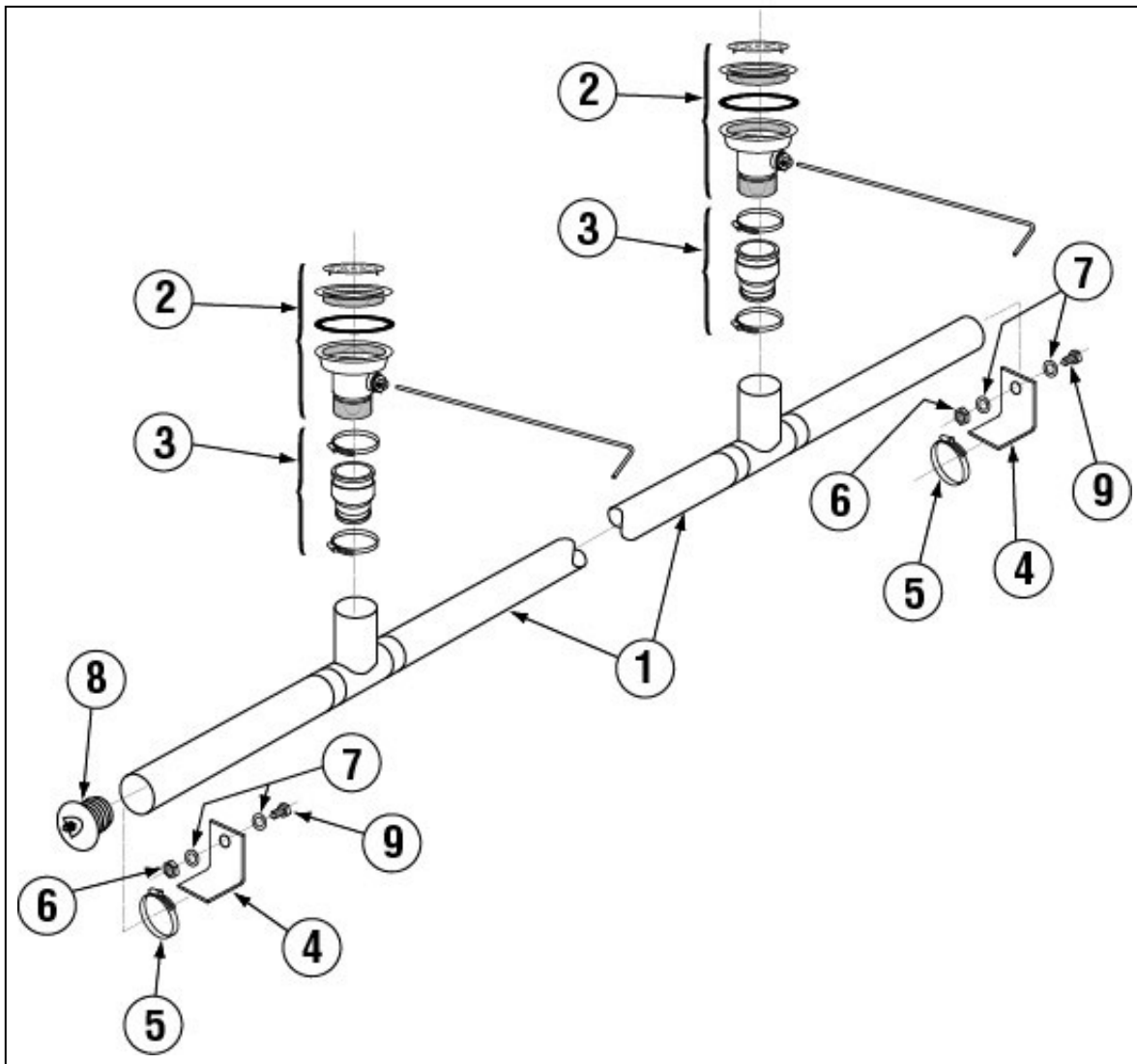

ITEM NO.	NO. REQ'D	P/N	DESCRIPTION
1	1	13001.85	Drain Manifold
2	2	20500.06	Waste Drain Valve
--	2	20500.10	Waste Drain Valve O-Ring Gasket
3	2	01317.17	1-1/2" x 2" No Hub
4	2	13001.26	Drain Support Bracket
5	2	50109.00	Hose Clamp

ITEM NO.	NO. REQ'D	P/N	DESCRIPTION
6	2	00912.00	1/4-20 Lock Nut
7	4	00924.00	1/4" Washer, SS
8	1	13024.00	Dynamite Plug, 2"
9	2	00906.0	1/4-20 x 1/2" Hex Head Bolt

Parts Manual

1.2.13. Plumbing System Assembly (Auto-Fill)

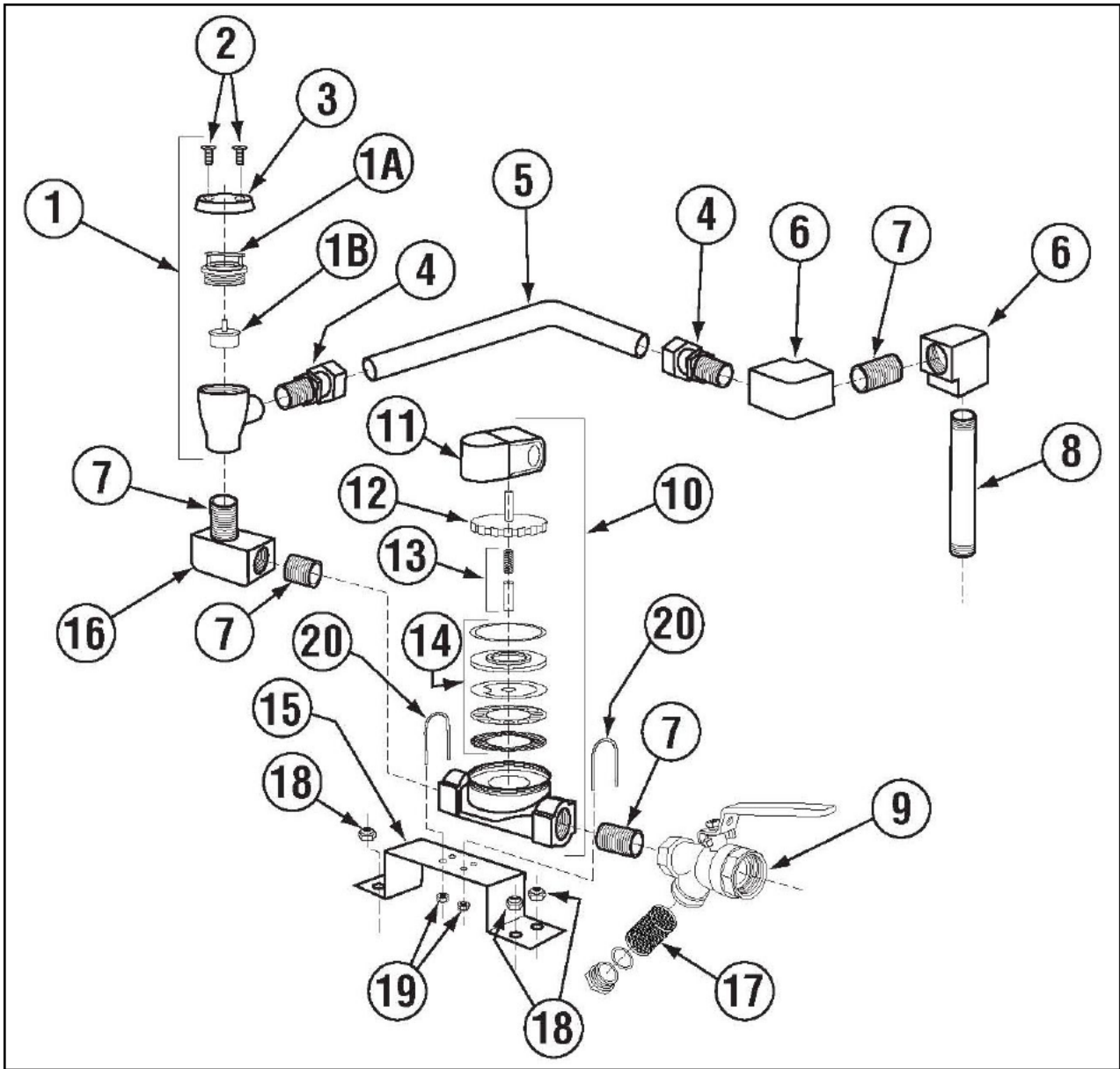

ITEM NO.	NO. REQ'D	P/N	DESCRIPTION
1	1	03624.00	1/2" Vacuum Breaker, Watts**
1A	1	03624.25	1/2" Vacuum Breaker Bonnet
1B	1	03623.00	1/2" Vacuum Breaker Repair Kit
2	2	00421.51	6-32 x 1/4" SS Panhead Screw
3	1	00739.50	Vacuum Breaker Cap
4	2	00760.00	5/8 Comp x 1/2 MIP Adapter
5	1	13608.00	EST-44 Water Inlet Tube SS
6	2	41030.10	1/2 90 Deg Ell Fx F Brass
7	3	00742.00	Nipple Brass 1/2 x 1 1/2
8	1	00747.10	Nipple Brass 1/2 x 5
9	1	41062.00	1/2 Strainer Ball Valve*

ITEM NO.	NO. REQ'D	P/N	DESCRIPTION
10	1	03603.15	1/2" Water Solenoid Valve 220V, JE
11	1	00738.15	Water Solenoid Valve Coil, 220V, 3/4" & 1/2"
12	1	03603.20	1/2" Water Solenoid Valve Bonnet
13	1	00786.00	Water Solenoid Plunger with Spring
14	1	00707.00	1/2" Water Solenoid Valve Repair Kit
15	1	01525.06	Plumbing Support Bracket
16	1	00745.00	1/2 90 Deg Street E bow
17	1	41062.10	1/2 Ball Valve Strainer
18	4	00912.00	1/4-20 Nylon Lock Nut
19	4	00912.00	1/4-20 Nylon Lock Nut
20	2	01526.10	Plumbing Bracket Strap

Parts Manual

1.2.14. Plumbing System Assembly (Final Rinse)

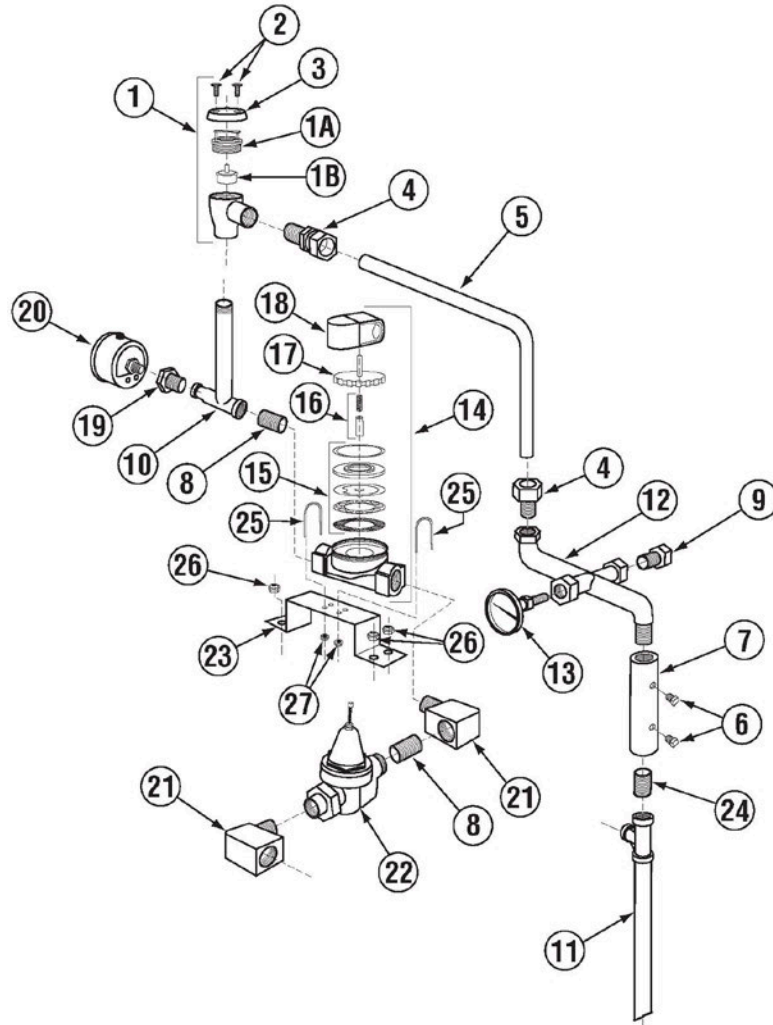

ITEM NO.	NO. REQ'D	P/N	DESCRIPTION
1	1	03624.00	1/2" Vacuum Breaker, Watts**
1A	1	03624.25	1/2" Vacuum Breaker Bonnet
1B	1	03623.00	1/2" Vacuum Breaker Repair Kit
2	2	00421.51	6-32 x 1/4" SS Panhead Screw
3	1	00739.50	Vacuum Breaker Cap
4	2	00760.00	5/8 Comp x 1/2 MIP Adapter
5	1	13608.50	EST-44 Final Rinse Plumbing Tube
	1	13608.55	Same, but For Units with E Temp
6	2	03232.00	1/8 Male Plug
7	1	13669.21	Mixing Chamber SS
8	3	00742.00	Nipple Brass 1/2 x 1 1/2
9	1	13631.50	Plumbing Connection Plug
10	1	13644.00	EST Vacuum Breaker Conn.
11	1	13307.30	EST44/66 Final Rinse Tube Assy.
12	1	13631.00	Mixing Chamber Plumbing Connect

ITEM NO.	NO. REQ'D	P/N	DESCRIPTION
13	1	00120.02	Bi Metal Thermometer
14	1	03603.15	1/2" Water Solenoid Valve 220V, JE*
15	1	00707.00	1/2" Water Solenoid Valve Repair Kit
16	1	00786.00	Water Solenoid Plunger with Spring
17	1	03603.20	1/2" Water Solenoid Valve Bonnet
18	1	00738.15	Water Solenoid Valve Coil, 220V, 3/4" & 1/2"
19	1	13604.00	1/2 x 1/4 Bushing Brass
20	1	13605.45	Pressure Gauge (CMA-180)
21	3	00745.00	1/2 90 Deg Street Elbow
22	1	13602.28	1/2" Pressure Regulator
23	1	01525.06	Plumbing Support Bracket
24	3	13629.00	Nipple SS 1/2 x Close
25	2	01526.10	Plumbing Bracket Strap
26	4	00912.00	1/4-20 Nylon Lock Nut
27	4	00912.00	1/4-20 Nylon Lock Nut

Parts Manual

1.2.15. Wash System Assembly

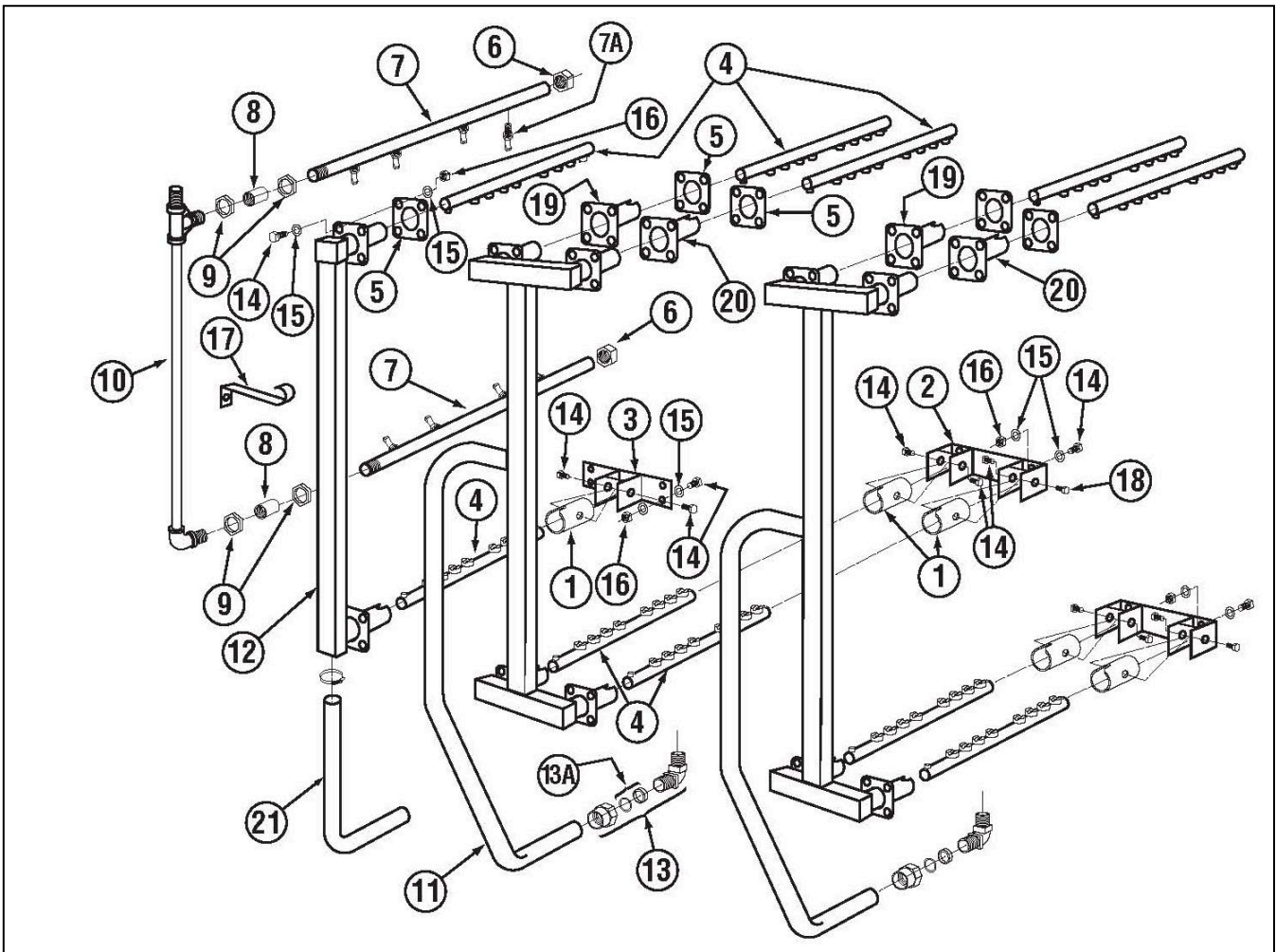

ITEM NO.	NO. REQ'D	P/N	DESCRIPTION
1	10	13305.06	Spray Arm End Cap
2	4	13327.06	Socket Bracket, Double
3	2	13327.26	Socket Bracket, Single
4	10	13303.17	Spay Arm
5	10	04306.10	Square Manifold Gasket
6	2	13310.00	1/2" Cap, Brass
7	2	13304.83	Final Rinse Spay Arm*
7A	8	13304.66	Final Rinse Spray Jets, SS
8	2	13618.00	1/2" Coupling
9	4	00721.20	1/2" Jamb Nut, Brass
10	1	13307.30	EST44/66 Final Rinse Tube Assy.
11	2	13301.16	Wash Manifold 03/15

ITEM NO.	NO. REQ'D	P/N	DESCRIPTION
12	1	13301.39	Rinse Manifold
13	1	00213.00	1" Ford Adapter, MIP x PJ Tube**
13A	1	00225.00	1" Compression Gasket
14	54	00914.10	1/4-20 x 5/8 Hexhead Bolt 304SS
15	54	00924.00	1/4" SS Washer
16	54	00912.00	1/4-20 Nylon Lock Nut
17	1	13304.53	Long Support Bracket
18	18	13305.40	Shoulder Bolt
19	2	13301.32	Upper Wash Arm Socket Left
20	2	13301.33	Upper Wash Arm Socket Right
21	1	03108.66	Transfer Hose 1" - 35"

Parts Manual

1.2.16. Rocker Arm Assembly

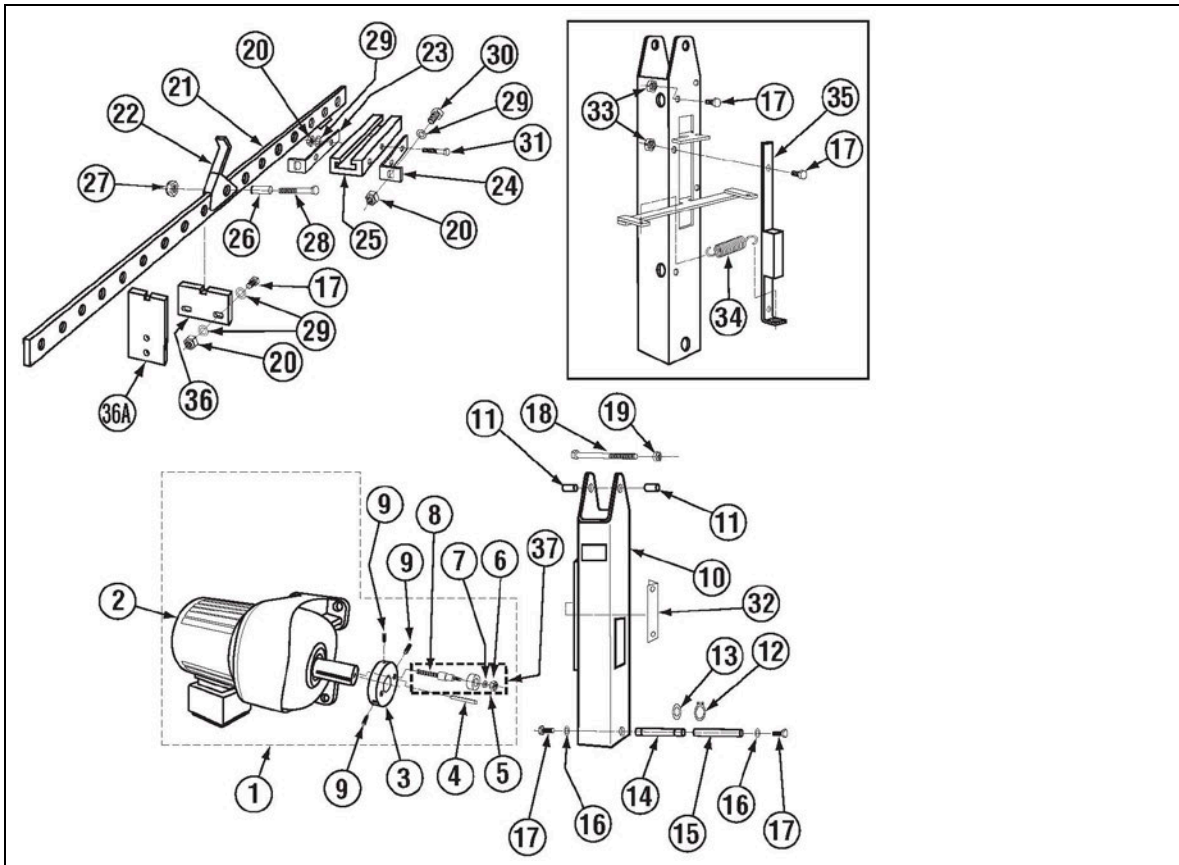

ITEM NO.	NO. REQ'D	P/N	DESCRIPTION
1	1	13571.00	EST Conveyor Drive Assy.3ph,230V
		13571.25	EST Conveyor Drive Assy.1ph,230V
2	1	13503.06	EST-44 Gearbox Motor Assy.3ph,230V
		13503.08	EST-44 Gearbox Motor Assy.1ph,230V
3	1	13505.14	EST-44 Drive Cam
4	1	13505.22	Keyway (Cam)
5	1	13507.20	Cam Bearing Only
6	1	13805.00	5/16-18 Nylon Insert Lock Nut
7	1	13507.11	Cam Bearing Shaft Spacer
8	1	13507.12	Cam Bearing Shaft
9	3	00935.22	1/4-20 x 1/2" Set Screw
10	1	13508.15	CMA 44 Rocker Arm
11	2	13513.10	Rocker Arm Spacer
12	2	13509.52	7/8" ID External Lock Ring
13	2	13509.53	1" ID Brass Washer
14	1	13509.12	CMA 44 Rocker Shaft Bearing
15	1	13510.10	Bearing Shaft
16	2	00922.00	1/4" Lock Star Washer
17	4	00914.00	1/4-20 x 3/4" Hex Head Bolt
18	1	13808.00	1/2-13 x 3-1/2"

ITEM NO.	NO. REQ'D	P/N	DESCRIPTION
19	1	13809.00	1/2-13 Nylon Lock Nut
20	1	00912.00	1/4-20 Nylon Lock Nut
21	1	13514.88	Conveyor Bar (17 Dogs)
22	17	13515.00	Conveyor Dog, SS
23	1	13514.82	Left Conveyor Bar Bracket
24	1	13514.84	Right Conveyor Bar Bracket
25	1	13521.50	Conveyor Bar Slide Bearing
26	17	13520.00	Conveyor Dog Bearing
27	17	13806.00	3/8" Nylon Lock Nut
28	17	13818.00	3/8-16 x 1-3/4" Hex Head Bolt
29	2	00924.00	1/4" SS Washer
30	2	00914.10	1/4-20 x 5/8" Hex Head Bolt
31	1	00903.00	1/4-20 x 1-3/4" Hex Head Bolt
32	1	13505.06	Cam Guide
33	4	00912.00	1/4-20 Nylon Lock Nut**
34	1	13508.70	Heavy Duty Clutch Spring
35	1	13508.26	Rack Saver Clutch Bar
36	1	13522.00	Conveyor Bar Guide starting 11/02
36A	1	13522.10	Conveyor Bar Guide starting 01/11
37	1	13507.65	Cam Bearing Assy. (12/07)

* Comes with capacitor P/N 13503.03

Rocker Arm Assembly R>L PN13508.44 or L>R PN13508.45
 - includes items 10,11, 12, 13, 14, 18, 19, 32, 34 AND 35 (L>R) or 36 (R>L)

Parts Manual

1.2.17. Start Switch and Rinse Switch Assembly (Effective May 2014)

1.2.17.1. Right-to-Left Assembly

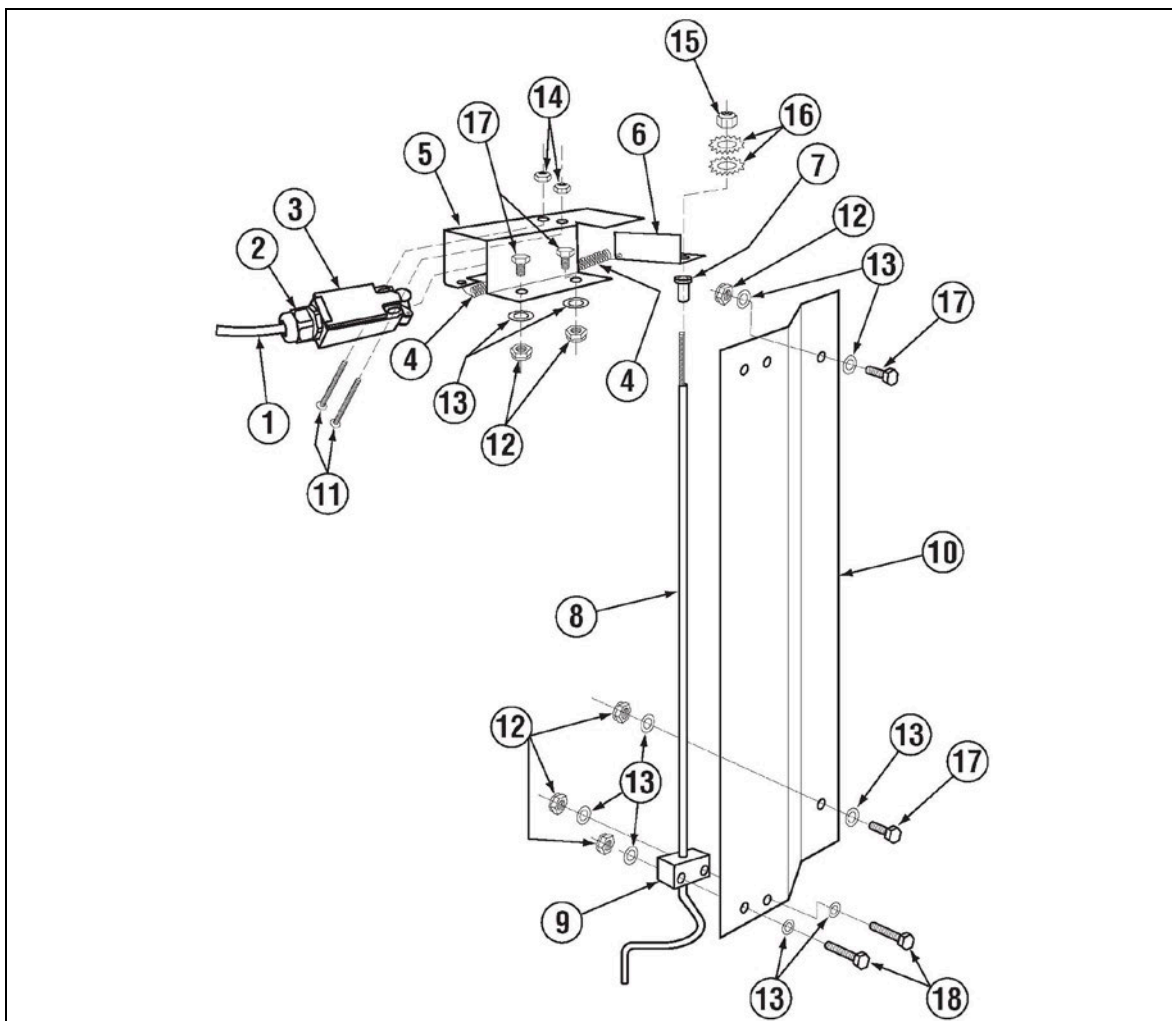

ITEM NO.	NO. REQ'D	P/N	DESCRIPTION
1	8'	00547.00	Switch Cord 18 AWG SOOW
2	2	00562.60	Connector-#562 Door Roller Switch
3	2	00562.00	Roller Door Switch
4	2	13408.64	Table Limit Switch Bracket Spring
5	2	13975.00	Conveyor Switch Housing R-L
6	2	13976.00	Conveyor Switch Activator Brkt R-L
7	2	13972.10	Conveyor Switch Rod Sleeve
8	2	13972.00	Conveyor Switch Rod R-L
9	2	13974.00	Conveyor Switch Rod Block UHMW

ITEM NO.	NO. REQ'D	P/N	DESCRIPTION
10	1	13973.00	Final Rinse Rod Shield <i>(final rinse only)</i>
11	2	00960.00	8-32 X 1 1/2 Panhead Screw
12	10	00912.00	1/4-20 Nylon Lock Nut
13	20	00926.00	5/16 SS Washer
14	4	00927.00	8-32 Nylon Lock Nut
15	2	00913.00	5/16-18 SS Nut
16	4	03807.30	5/16 External Lock Washer
17	6	00914.10	1/4-20 x 5/8 Hexhead Bolt 304SS
18	4	00910.00	1/4-20 x 1 1/2 SS Hexhead Bolt

Parts Manual

1.2.17.2. Left-to-Right Assembly

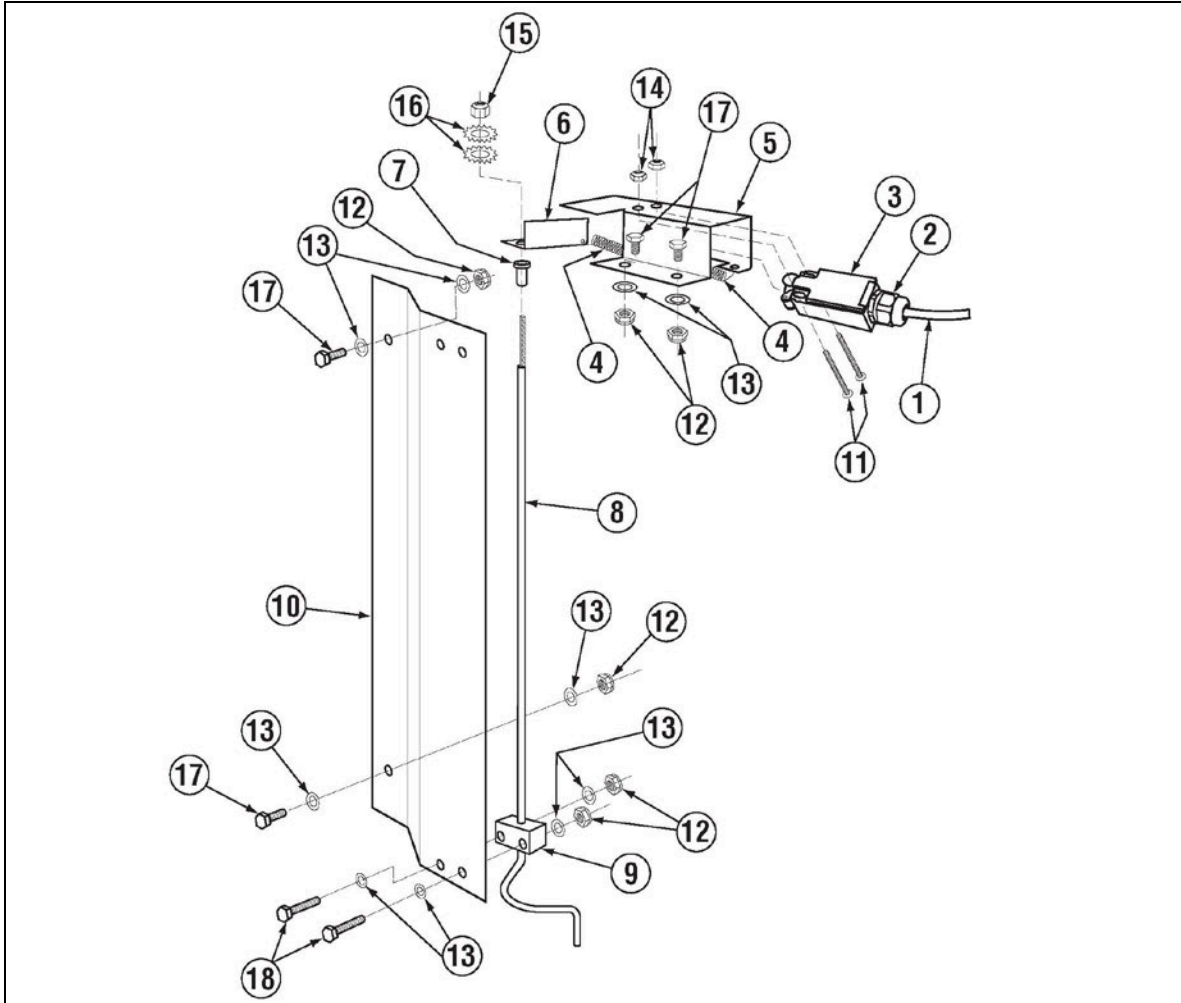

ITEM NO.	NO. REQ'D	P/N	DESCRIPTION
1	8'	00547.00	Switch Cord 18 AWG SOOW
2	2	00562.60	Connector-#562 Door Roller Switch
3	2	00562.00	Roller Door Switch
4	2	13408.64	Table Limit Switch Bracket Spring
5	2	13975.50	Conveyor Switch Housing L-R
6	2	13976.50	Conveyor Switch Activator Brkt L-R
7	2	13972.10	Conveyor Switch Rod Sleeve
8	2	13972.50	Conveyor Switch Rod L-R
9	2	13974.00	Conveyor Switch Rod Block UHMW

ITEM NO.	NO. REQ'D	P/N	DESCRIPTION
10	1	13973.00	Final Rinse Rod Shield (<i>final rinse only</i>)
11	2	00960.00	8-32 X 1 1/2 Panhead Screw
12	10	00912.00	1/4-20 Nylon Lock Nut
13	20	00926.00	5/16 SS Washer
14	4	00927.00	8-32 Nylon Lock Nut
15	2	00913.00	5/16-18 SS Nut
16	4	03807.30	5/16 External Lock Washer
17	6	00914.10	1/4-20 x 5/8 Hexhead Bolt 304SS
18	4	00910.00	1/4-20 x 1 1/2 SS Hexhead Bolt

Parts Manual

1.2.18. Start Switch and Rinse Switch Assembly

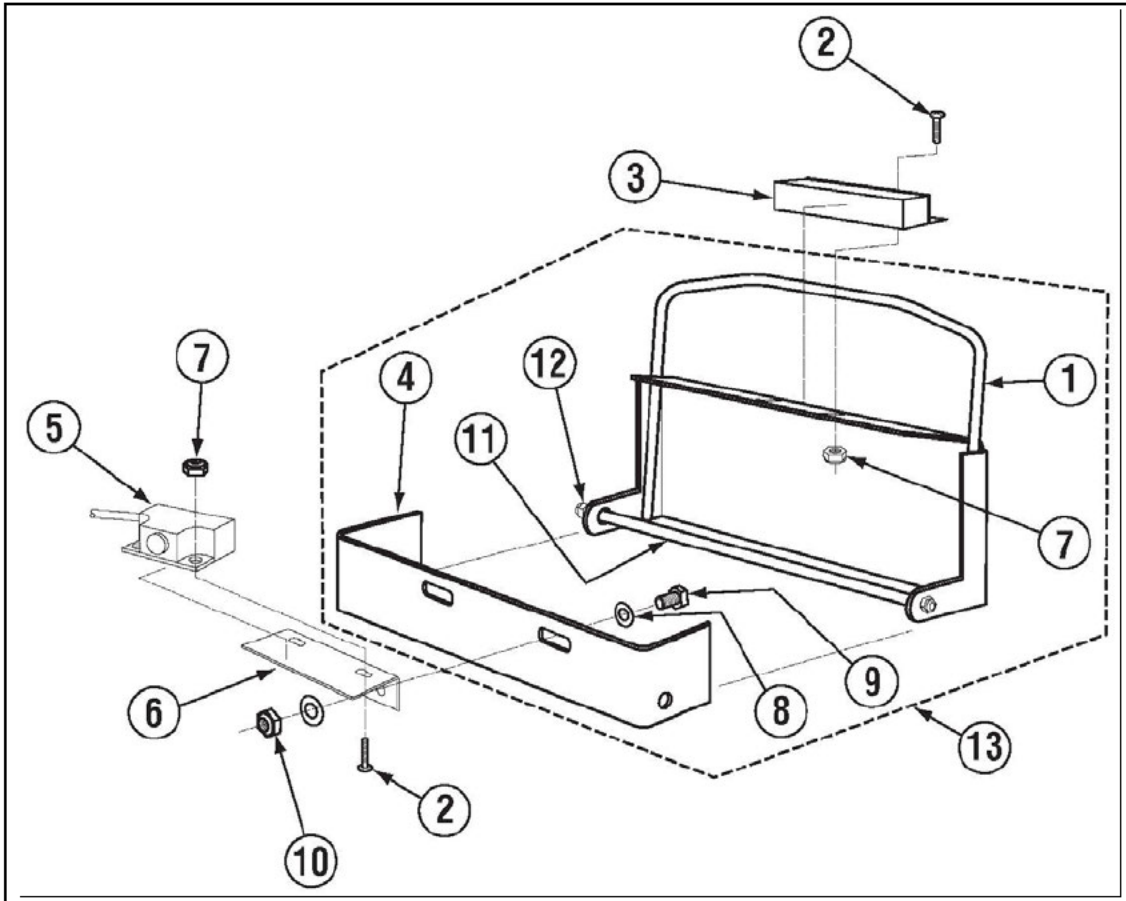

ITEM NO.	NO. REQ'D	P/N	DESCRIPTION
1	1	13408.61	Actuator Arm
2	4	00907.50	6-32 x 3/8" Pan Head Screw
3	1	00556.60	Reed Switch Magnet-ISI
4	1	13408.62	Actuator Bracket
5	1	00556.10	Reed Switch-ISI
6	1	13409.31	Reed Switch Bracket
7	4	00965.00	6-32 Nylon Lock Nut
8	4	00924.00	1/4" SS Washer
9	4	00906.00	1/2" -20 x 1/2" Hex Head Bolt
10	4	00912.00	1/2" - 20 Nylon Lock Nut
11	1	13408.59	Actuator Arm Shaft
12	2	13805.00	5/16" Nylon Lock Nut
13	1	13408.60	Actuator Assy.

1.2.19. Door Switch Assembly (Effective August, 2014)

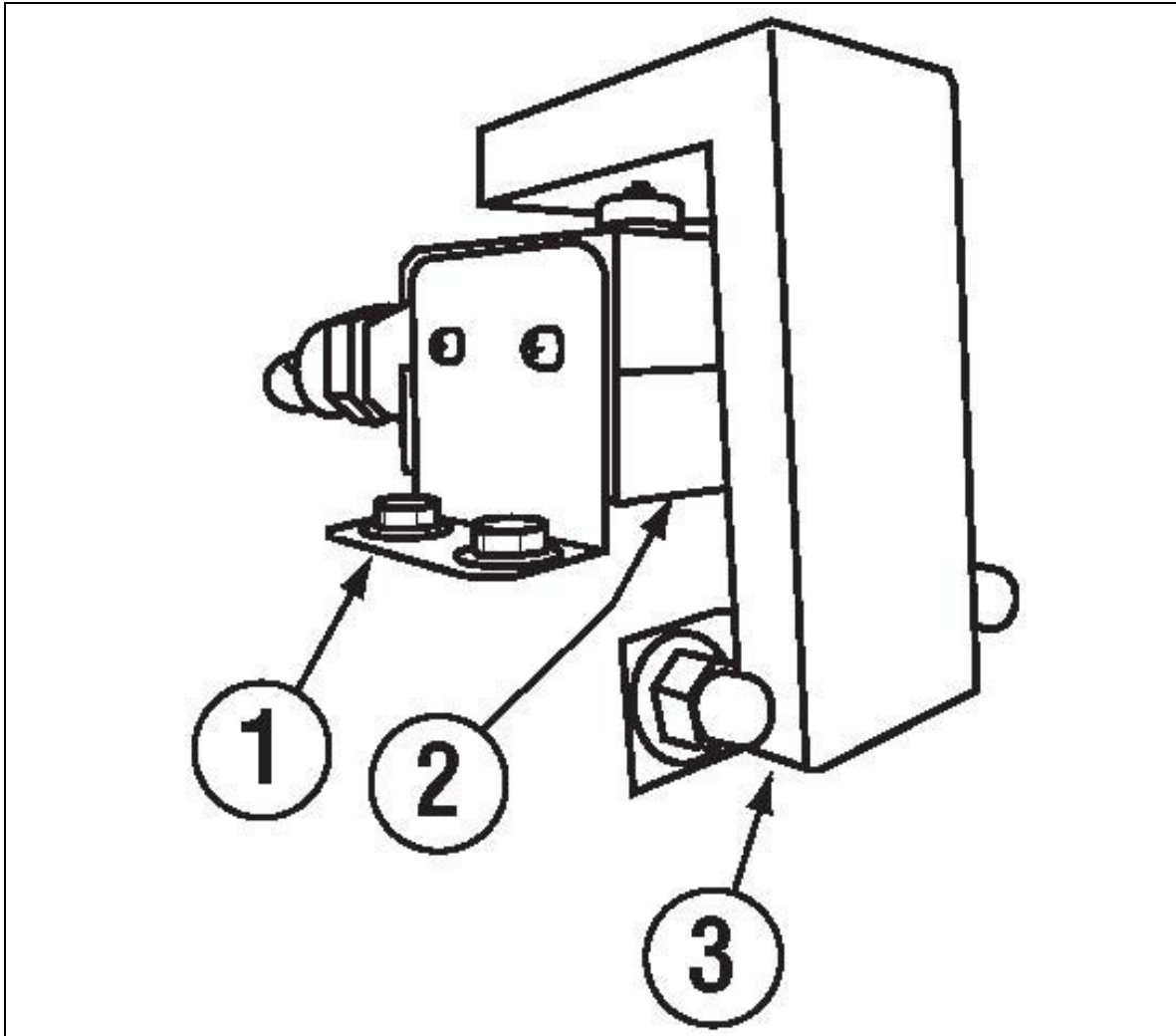

ITEM NO.	NO. REQ'D	P/N	DESCRIPTION
1	1	00471.87	Est44/66 Door Safety Switch Brkt
2	1	13427.10	Table Limit Switch (Push Button)
3	1	00471.88	Est44/6 Door Switch Actuator Bracket

Parts Manual

1.2.20. Optional E-Temp Heater (Effective September 1, 2018)

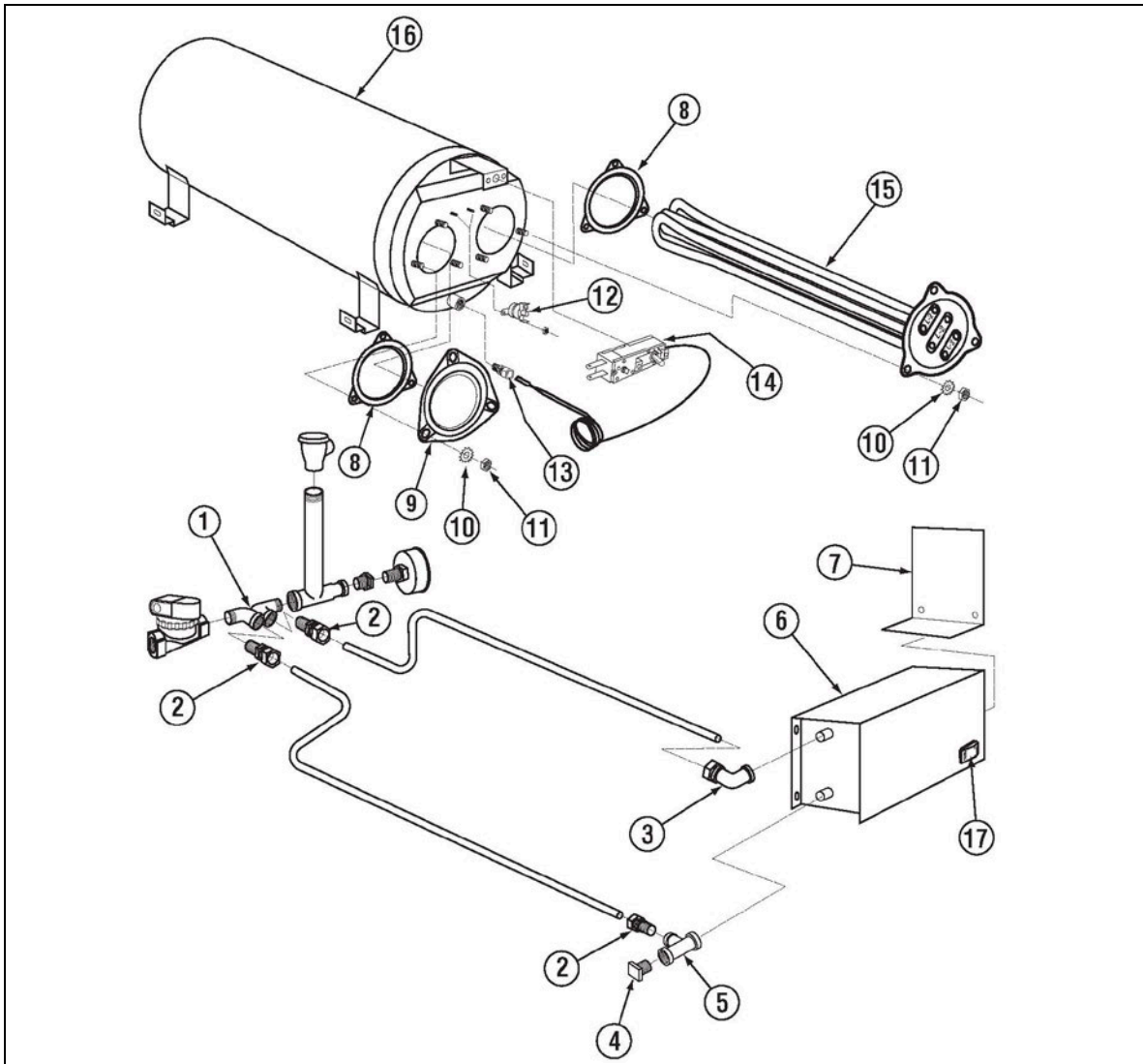

ITEM NO.	NO. REQ'D	P/N	DESCRIPTION
1	1	13620.20	Booster Heater 1/2 In/Out Adapter
2	3	00760.00	5/8 Comp x 1/2 MIP Adapter
3	1	17550.10	Inlet Booster Heater Plumbing Connt
4	1	13642.00	1/2" MIP Plug Brass Sq. Head
5	1	00743.10	1/2 Tee F x F x F Brass
6	1	13951.10	E-Temp Booster Shroud - Zoppas
7	1	13951.12	E-Temp Booster Access Cover
8	2	15518.11	Gasket for Triangular Flange Heater
9	1	13950.20	E-Temp Tank Plug for 40F Rise.

* Note : Use two heaters p/n [15518.00](#) and [13422.80](#) for 70 F Rise., not for single phase.

ITEM NO.	NO. REQ'D	P/N	DESCRIPTION
10	6	00924.00	1/4 SS Washer
11	6	00912.00	1/4-20 Nylon Lock Nut
12	1	17523.51	Hi Limit Switch 250Deg
13	1	13417.50	Thermostat Thermowell
14	1	13417.89	Heater Thermostat
15	1	13422.71	240V 12KW Triangular Immersion Htr*
16	1	13951.20	E-Temp Heater Tank
17	1	00421.83	Power Rocker Switch, Red

* 480V elements; PN[13422.75](#) 12kW; PN[13422.76](#) 6kW.

1.2.21. Optional E-Temp Heater

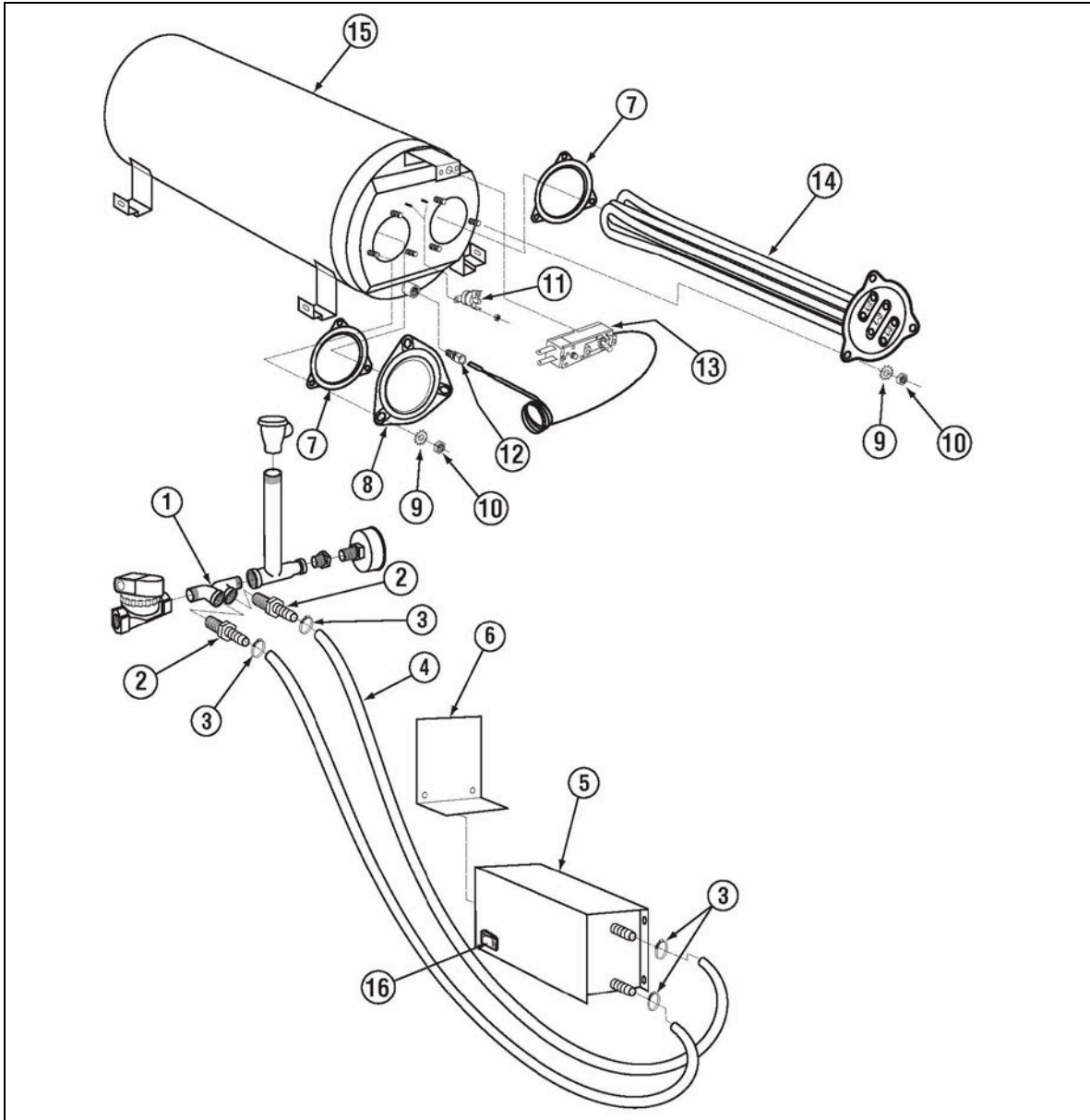

ITEM NO.	NO. REQ'D	P/N	DESCRIPTION
1	1	13620.20	Booster Heater 1/2 In/Out Adapter
2	2	40014.00	1/2m x 1/2 Barb Straight
3	4	03101.47	Hose Clamp # 6 size # 003
4	2	03107.62	Flexible Hose 1/2" X5 Ft
5	1	13951.10	E-Temp Booster Shroud - Zoppas
6	1	13951.12	E-Temp Booster Access Cover
7	2	15518.11	Gasket for Triangular Flange Heater
8	1	13950.20	E-Temp Tank Plug for 40F Rise.

ITEM NO.	NO. REQ'D	P/N	DESCRIPTION
9	6	00924.00	1/4 SS Washer
10	6	00912.00	1/4-20 Nylon Lock Nut
11	1	17523.51	Hi Limit Switch 250Deg
12	1	40116.00	1/4 Comp x 1/4 MIP Ftg
13	1	13417.89	Heater Thermostat
14	1	13422.71	240V 12KW Triangular Immersion Htr*
15	1	13951.20	E-Temp Heater Tank
16	1	00421.83	Power Rocker Switch, Red

* Note : Use two heaters p/n [15518.00](#) and [13422.80](#) for 70 F Rise., not for single phase.

Parts Manual

1.2.22. Unique Parts For EST-66 Tall machines.

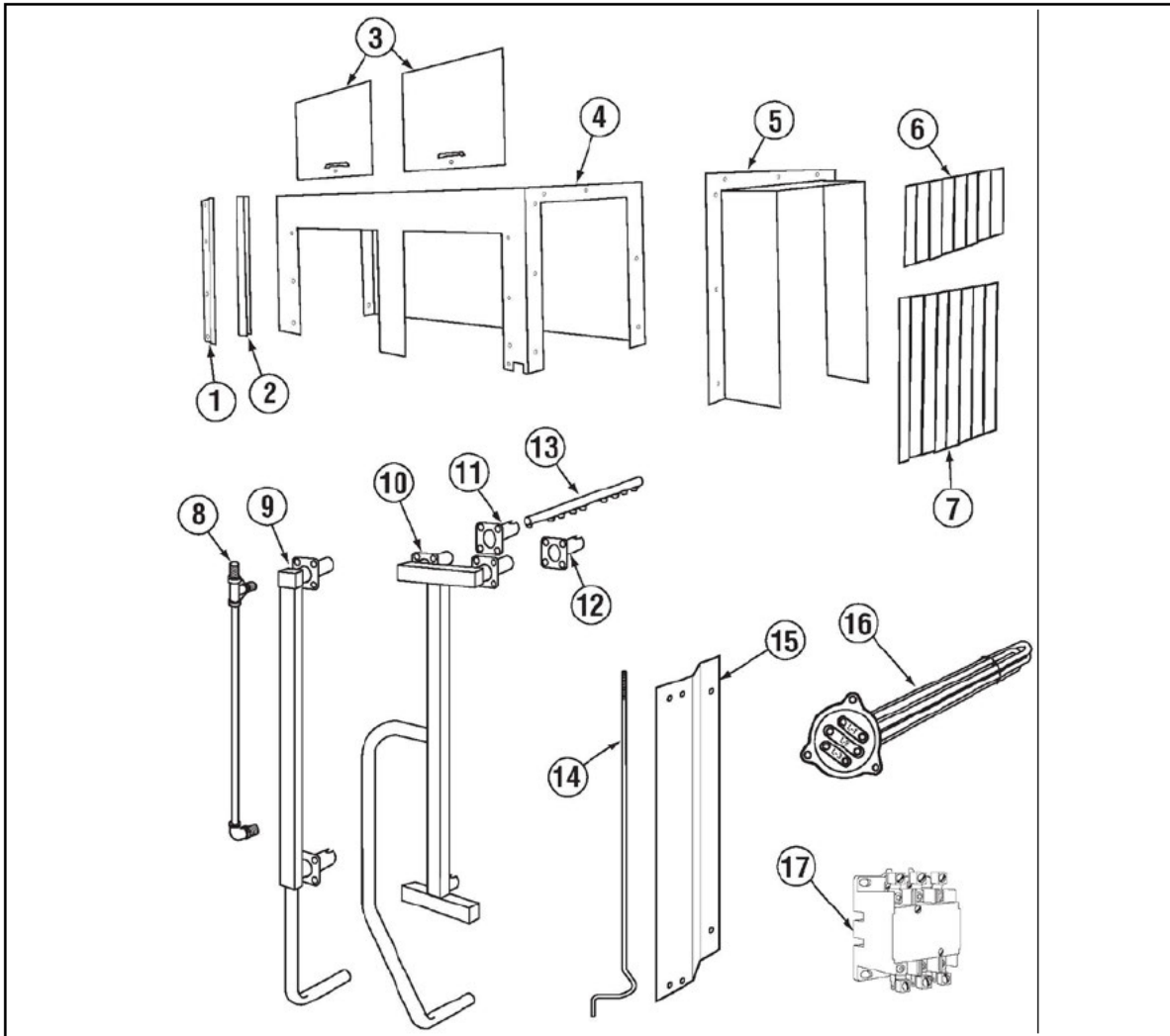

ITEM NO.	NO. REQ'D	P/N	DESCRIPTION
1	4	13936.50	Conveyor Door Guide 6" Taller
2	4	00636.30	EZ Glide Door Guide 32 1/4"
3	2	13936.00	Conveyor Door 6" Taller
4	1	13935.55	EST- 66 Wrapper L-R 6" Taller
	1	13935.58	EST- 66 Wrapper R-L 6" Taller
5	2	13938.00	Conveyor Wrapper Shield 6" Taller
6	1	13702.30	Curtain CMA-44 24 5/8" x 15
7	2	13703.61	Curtain CMA-44/66 20 5/8 x 21
8	1	13307.32	^EST-44/66 Final Rinse Tube Tall
9	1	13937.57	Conveyor Rinse Mani L-R 6" Taller
	1	13937.58	Conveyor Rinse Mani R-L 6" Taller

ITEM NO.	NO. REQ'D	P/N	DESCRIPTION
10	2	13938.16	Conveyor Wash Manifold Tall 03/16
11	2	13301.35	Upper Wash Arm Socket Left Tall
12	2	13301.36	Upper Wash Arm Socket Right Tall
13	10	13303.26	^Spray Arm CMA-44P (Special) .175
14	2	13972.60	Conveyor Switch Rod L-R Tall
	2	13972.20	Conveyor Switch Rod R-L Tall
15	1	13973.50	Final Rinse Rod Shield Tall
16	1	13422.84	Immersion Heater 15Kw 208V T-Flange
17	1	13003.17	Contactor 60 Amp 3 Pole

2. Table Limit Switch (P/N 13469.20)

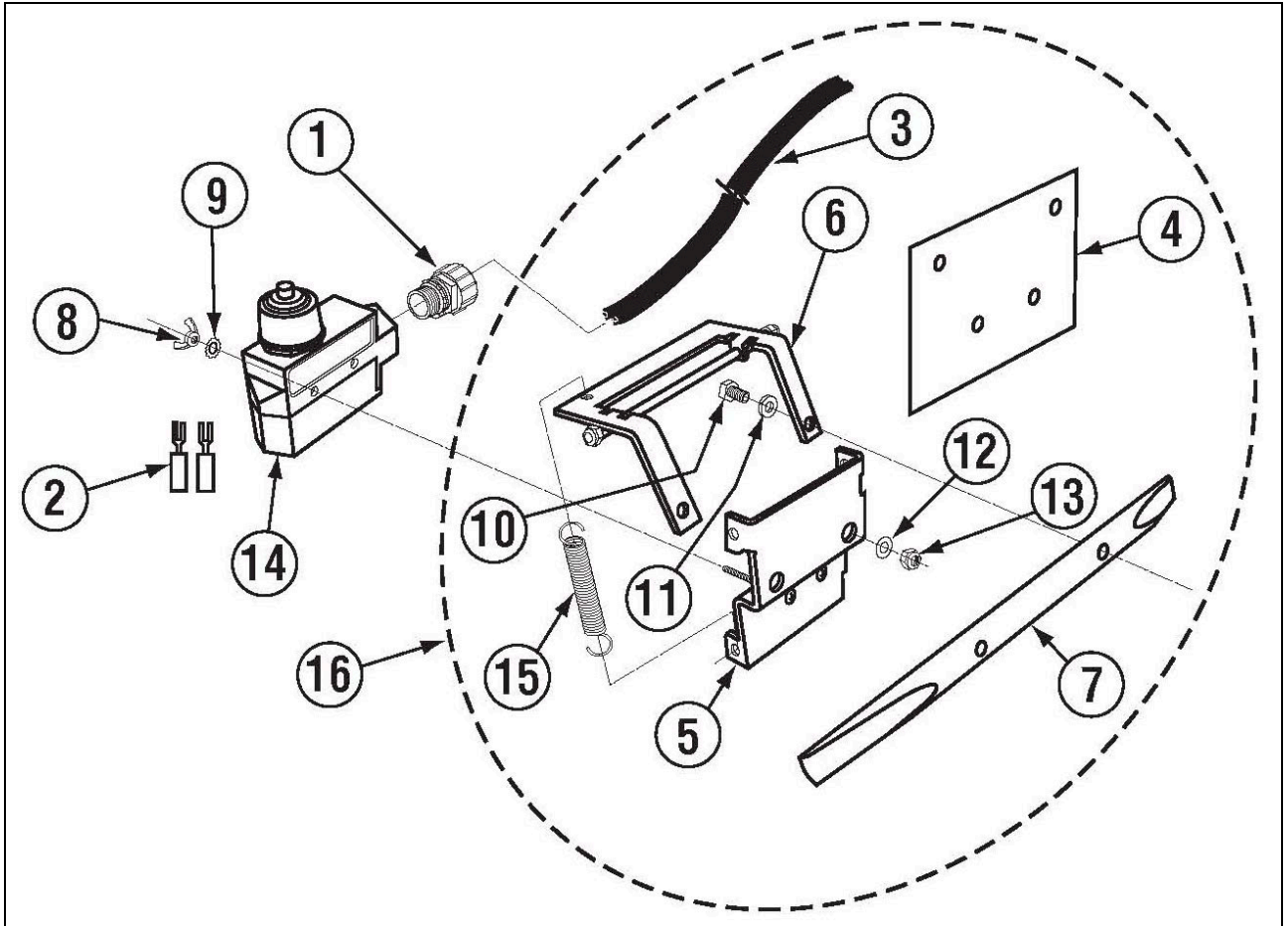

ITEM NO.	NO. REQ'D	P/N	DESCRIPTION
1	1	13427.12	Connector for Table Limit Switch
2	2	00446.60	Ring Eyelet Connector 14-16 #8
3	14 FT	00547.00	Switch Cord 18 AWG SOOW
4	1	13427.60	Template kit
5	1	13427.61	Mounting bracket
6	1	13427.62	Actuator
7	1	13427.63	Bumper
8	2	03817.00	6-32 wing nut
9	2	03814.10	Lock star washer
10	2	00914.10	1/4-20 x 5/8 hexhead bolt
11	2	00968.00	1/4 split lock washer
12	2	00924.00	1/4 ss washer
13	2	00912.00	1/4-20 nylon lock nut
14	1	13427.10	Limit switch
15	1	13408.64	Switch Bracket Spring
16	1	13427.50	Table Limit Switch Bracket Ass'y

3. Drain Water Tempering Kit (Optional)

CMA-180, EST-44, EST-66 WATER TEMPERING VALVE KIT P/N 13470.10

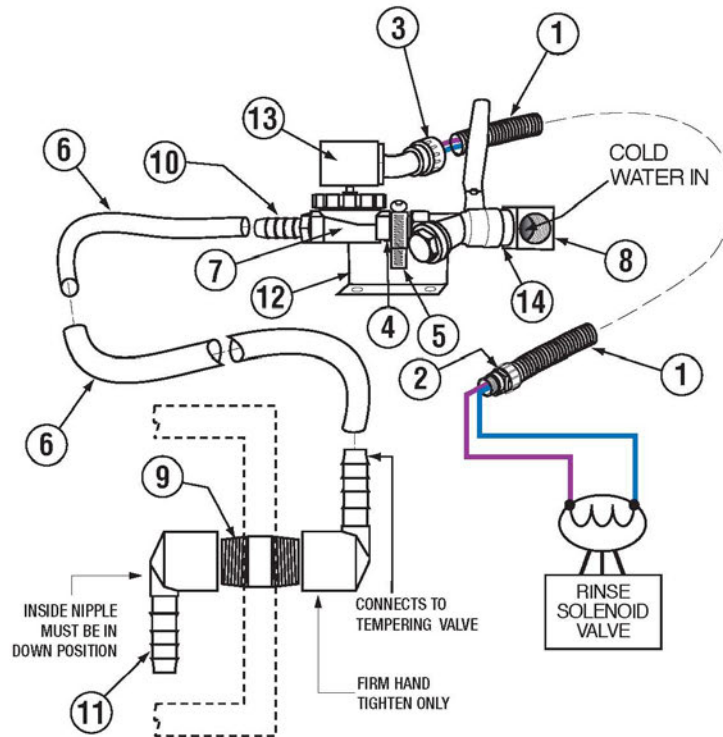

ITEM NO.	P/N	NO REQ'D	DESCRIPTION
1.	00400.00	2	CONDUIT 3/8" SEALTITE
2.	00401.00	1	ST-3/8" STRAIGHT CONNECTOR
3.	00402.00	1	ST-90 DEG 3/8" COONNECTOR
4.	00742.00	1	NIPPLE BRASS 1/2X1-1/2"
5.	03101.00	1	HOSE CLAMP #16 1"
6.	03106.45	5	BRAIDED HOSE 1/2"
7.	03603.15	1	WATER SOLENOID VALVE 1/2"
8.	41030.10	1	1/2" 90 DEG. ELL X F BRASS
9.	13472.00	1	NIPPLE PVC 1/2"X CLOSE
10.	13472.40	1	ADAPTER PVC 1/2" MALE X 1/2" BARB
11.	13472.50	2	ELBOW PVC 90 DEG F X BARB
12.	14508.50	1	PLUMBING BRACKET (180-UC)
13.	00738.15	1	SOLENOID VALVE COIL 220V
14.	41062.00	1	1/2" STRAINER BALL VALVE

2-2013

Parts Manual

Drain Water Tempering Valve Assembly (Effective 03-2023) PN13475.03 Factory Installed Kit PN13476.03 Field Installed Kit

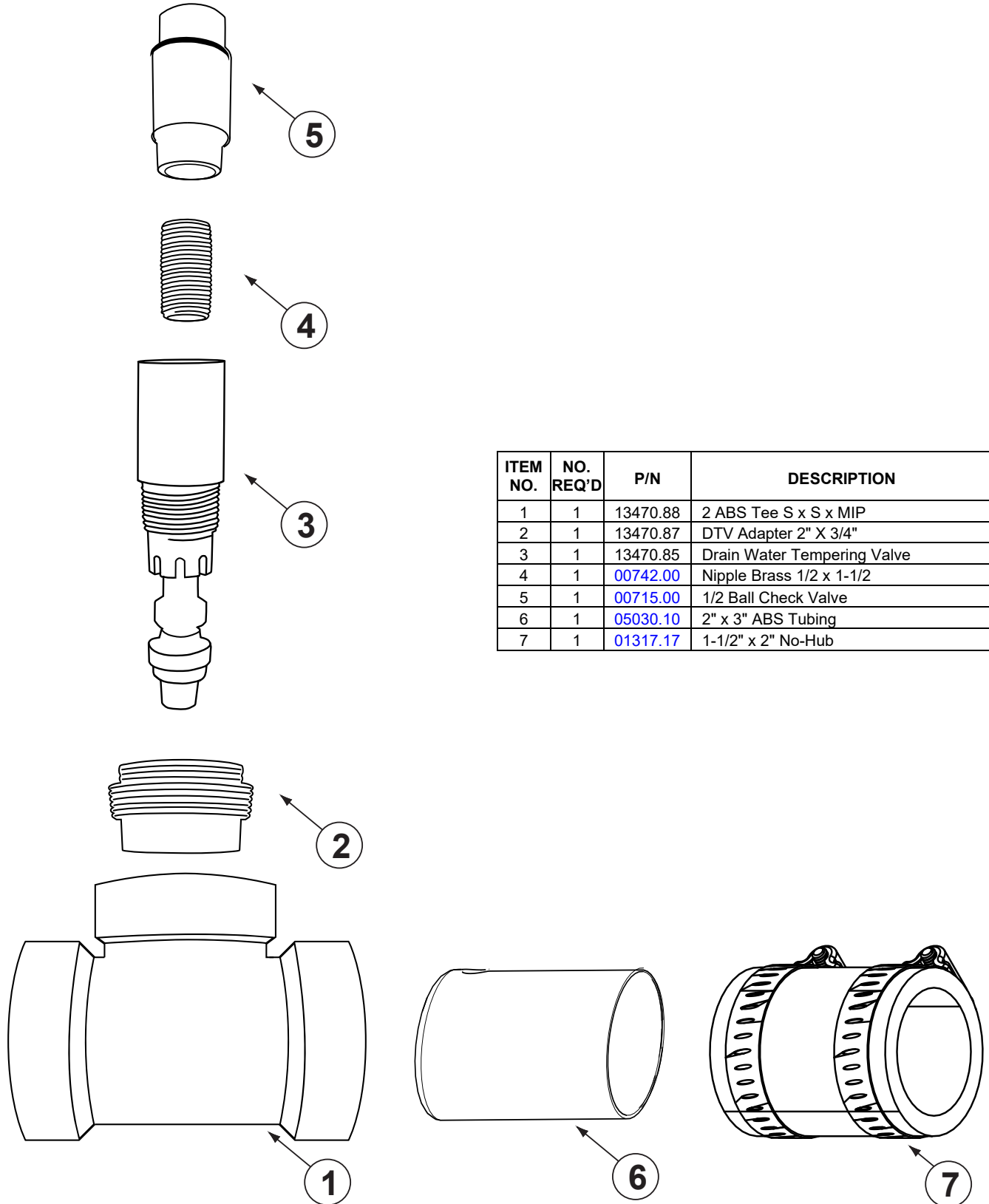

ITEM NO.	NO. REQ'D	P/N	DESCRIPTION
1	1	13470.88	2 ABS Tee S x S x MIP
2	1	13470.87	DTV Adapter 2" X 3/4"
3	1	13470.85	Drain Water Tempering Valve
4	1	00742.00	Nipple Brass 1/2 x 1-1/2
5	1	00715.00	1/2 Ball Check Valve
6	1	05030.10	2" x 3" ABS Tubing
7	1	01317.17	1-1/2" x 2" No-Hub