



**MODELS
EST-FL
PARTS MANUAL
Rev 1.00A**



**CMA DISHMACHINES
12700 KNOTT STREET
GARDEN GROVE, CALIFORNIA 92841
800-854-6417
FAX 714-895-2141**

www.cmadishmachines.com

[Buy Parts](#)

TABLE OF CONTENTS

MODEL EST

1. PARTS MANUAL	3
1.1. INITIAL PARTS KIT (P/N 01100.84).....	3
1.2. OPTIONAL SANI ALARM	4
1.3. EXPLODED VIEW DRAWINGS.....	5
1.3.1. Cabinet Assembly	5
1.3.1. Door Assembly.....	6
1.3.2. Control Box Assembly	7
1.3.3. Pump Assembly.....	8
1.3.4. Plumbing System Assembly.....	9
1.3.5. Spray System Assembly.....	9
1.3.6. Power Drain Assembly	11
1.3.7. Power Drain Retrofit Kit p/n 00104.95	12
1.3.8. Peristaltic Pump Assembly	13
1.3.9. Sustainer Heater (Optional)	14

1. Parts Manual

1.1. Initial Parts Kit (P/N 01100.84)

P/N	DESCRIPTION	Qty
00104.50	Drain Motor, 120V 60Hz	1
00108.83	Drain Actuator Arm (V)	1
00109.60	Drain Actuator Shaft (V)	1
00115.87	Drain Screen	1
00120.02	Thermometer	1
00121.60	Drain Diaphragm	1
00200.10	Pump Assembly, 110/220V 60Hz	1
00206.30	Pump Seal Kit	1
00304.06	Spray Arm	1
00308.50	Spray Arm End Plug, SS	1
00341.00	Spray Arm Bearing	1
00406.00	Control Box Light, .5" Diameter, Red	1
00407.83	Timer, 90 Sec, 8 Cam	1
00416.00	Peristaltic Pump Assembly, 120V/60Hz	1
00425.51	Chemical Tubing Blue	1
00425.53	Chemical Tubing Red	1
00425.54	Chemical Tubing White	1
00470.10	Toggle Switch Rubber Boot	3
00471.10	Toggle Switch, Off/On, 20-Amp	1
00475.70	Toggle Switch, DPDT, 15-Amp, Delimer	1
00631.00	Ice Cube Relay, 120V	1
00707.00	1/2" Water Solenoid Repair Kit, JE	1
00738.10	Solenoid Coil, JE, 120V (3/4" & 1/2")	1
00938.82	1/2" Drain Bushing, Brass (V)	2
00966.10	10-32X1/4 Hexhead SS Bolt	1
02257.00	Squeeze Tube Norprene	1
03415.45	Flex-Tight Fitting	1
03470.00	Toggle Switch, Momentary, Screw Terminals	1
03623.00	1/2" Vacuum Breaker Repair Kit, Watts	1
04103.14	Drain Valve Spring	1

1.2. *Optional Sani Alarm*

Part Number **12508.00**

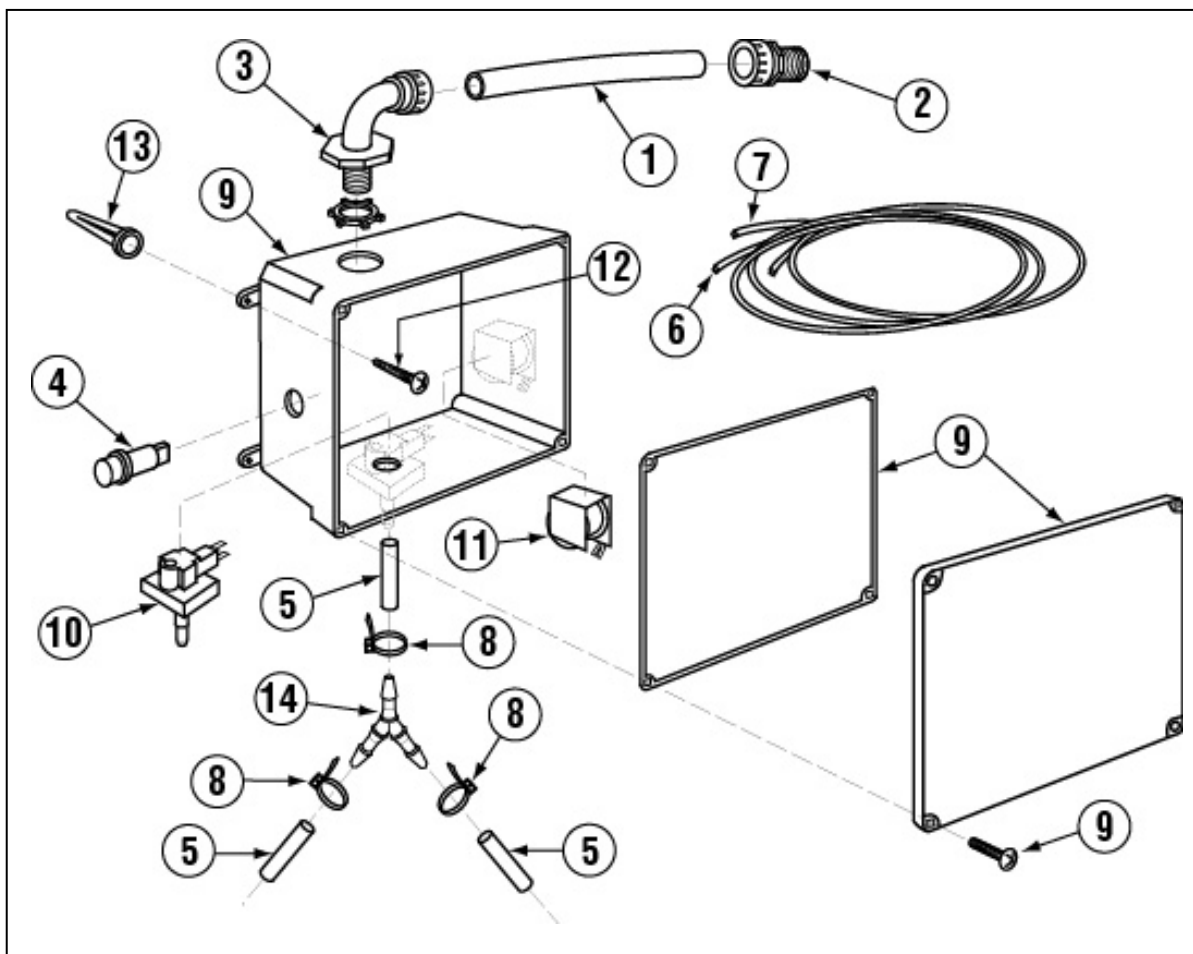

Exploded View

ITEM NO.	NO. REQ'D	P/N	DESCRIPTION
1	3	00400.00	Conduit, 3/8" Sealtite
2	1	00401.00	S.T. 3/8" Straight Connector
3	1	00402.00	S.T. 90 Degree 3/8" Connector
4	1	00406.00	Control Box Light, .5" Diameter, Red
5	1	00435.00	Squeeze Tube, 8"
6	1	00521.00	Wire, 18 Gauge, Orange, 6 ft.
7	1	00531.00	Wire, 18 Gauge, White, 6 ft.

ITEM NO.	NO. REQ'D	P/N	DESCRIPTION
8	5	00931.00	Wire Tie, Small
9	1	12510.00	Sanitizer Alarm Box Assembly
10	1	12511.50	Sanitizer Low Level Vacuum Switch
11	1	12512.00	Sanitizer Alarm Buzzer, 120 Volts
12	4	40126.10	#10 x 3/4" Sheet metal Screw
13	4	40127.00	Wall Anchors
14	1	00426.00	Y Hose Connector, 3/16"

1.3. Exploded View Drawings

1.3.1. Cabinet Assembly

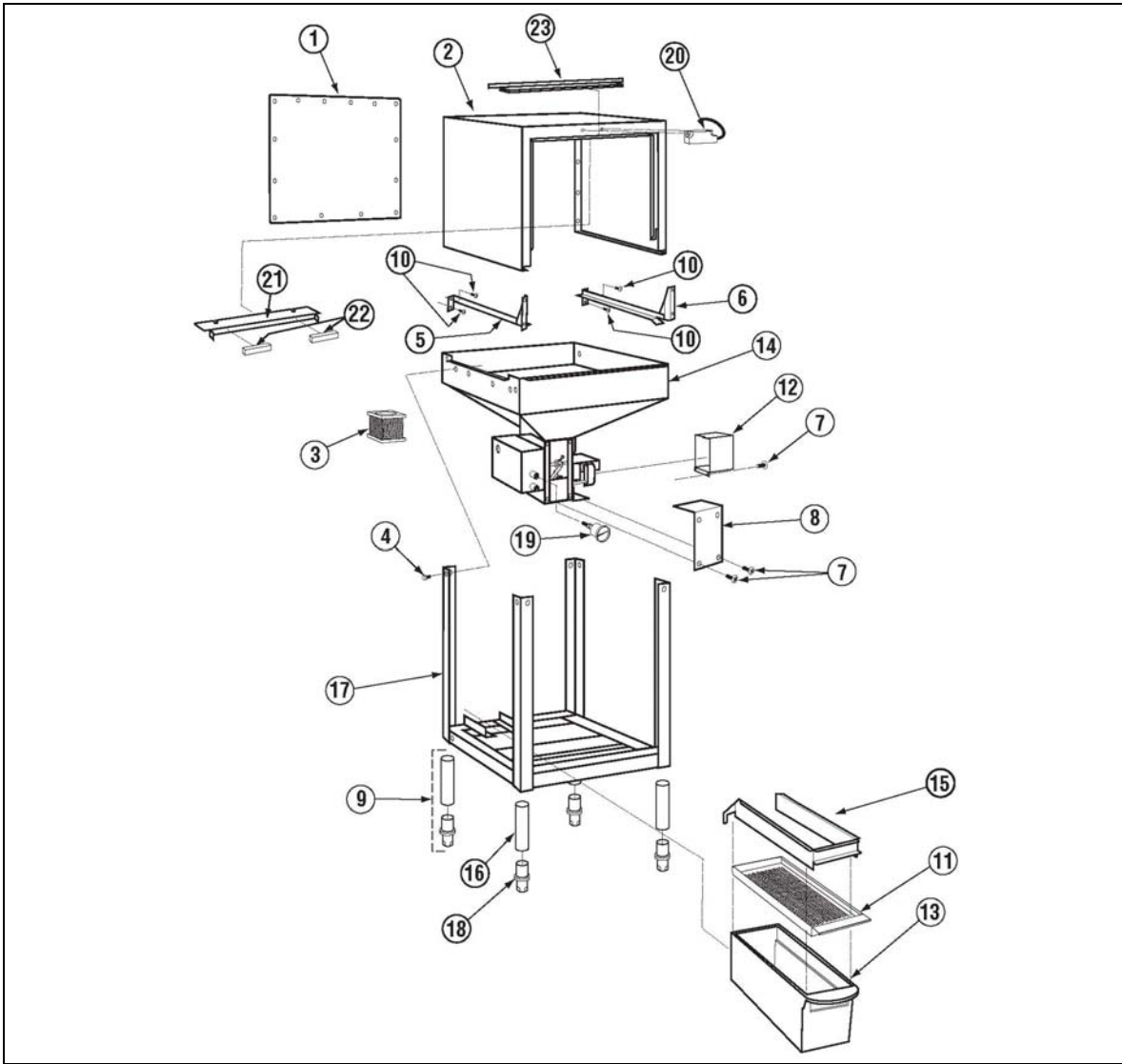

ITEM NO.	NO. REQ'D	P/N	DESCRIPTION
1	1	01512.10	EST Front Loader Wrapper Panel
2	1	01512.00	EST Front Loader Wrapper
3	1	00115.87	Drain Screen
4	18	00906.00	1/4-20 x 1/2" Hex head Bolt
5	1	01505.51	EST Front Loader LH Tray Track
6	1	01505.50	EST Front Loader RH Tray Track
7	6	00940.50	10-32 x 3/8" Truss Head Screw
8	1	00120.40	EVA Power Drain Cover
9	4	01145.00	Leg Ass'y 10" wAdjustable Socket
10	4	00914.00	1/4-20 x 3/4" Hex Head Bolt
11	1	01577.21	S/S Scrap Trap Drawer

ITEM NO.	NO. REQ'D	P/N	DESCRIPTION
12	1	01573.30	Sani Mount/Drain Lid
13	1	01577.10	Scrap Trap Body
14	1	1502.90	EST Pan
15	1	01579.50	EVA Splash Card
16	4	01572.10	SS Leg
17	1	01502.95	EST Stand
18	4	01310.00	Bullet Foot
19	1	00120.02	Thermometer (Bi Metal)
20	1	0556.10	Reed Switch - ISI
21	1	14558.30	EST Front Loader Body Magnet Holder
22	2	00557.80	Door Magnet (L-1X/CMA-180UC/GL-X)
23	1	14506.30	EST Front Loader Gasket Bracket

1.3.1. Door Assembly

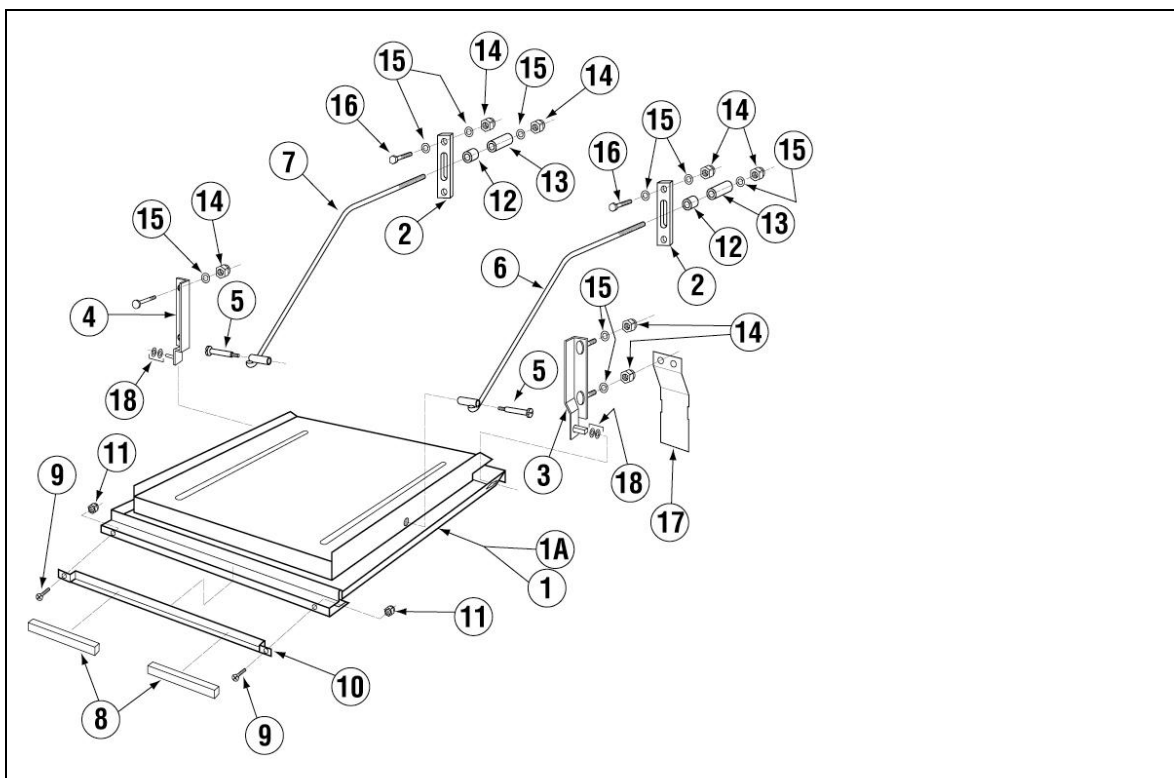

ITEM NO.	NO. REQ'D	P/N	DESCRIPTION
1	1	14506.00	Door for L-1X16
2	2	04517.60	Door Support Rod Block
3	1	14570.00	Door Hinge (RH)
4	1	14570.50	Door Hinge (LR)
5	2	04919.00	Door Rod Screw Pin for Door
6	1	04918.60	Door Support Rod Right
7	1	04919.50	Door Support Rod Left
8	3	00557.80	Door Magnet
9	2	00970.60	6 32 x 1/2" Flathead Screw

ITEM NO.	NO. REQ'D	P/N	DESCRIPTION
10	1	14558.61	Door Magnet Holder
11	2	00965.00	06-32 Lock Nut
12	2	00605.30	Door Rod Spacer
13	2	04517.15	Door Stop (Parallel)
14	10	00912.00	1/4"-20 Nylon Lock Nut
15	14	00924.00	1/4" SS Washer
16	4	00914.10	1/4"-20 x 5/8" Hex Head Bolt
17	2	14518.00	Splash Guard
18	4	00924.00	1/4 SS Washer

1.3.2. Control Box Assembly

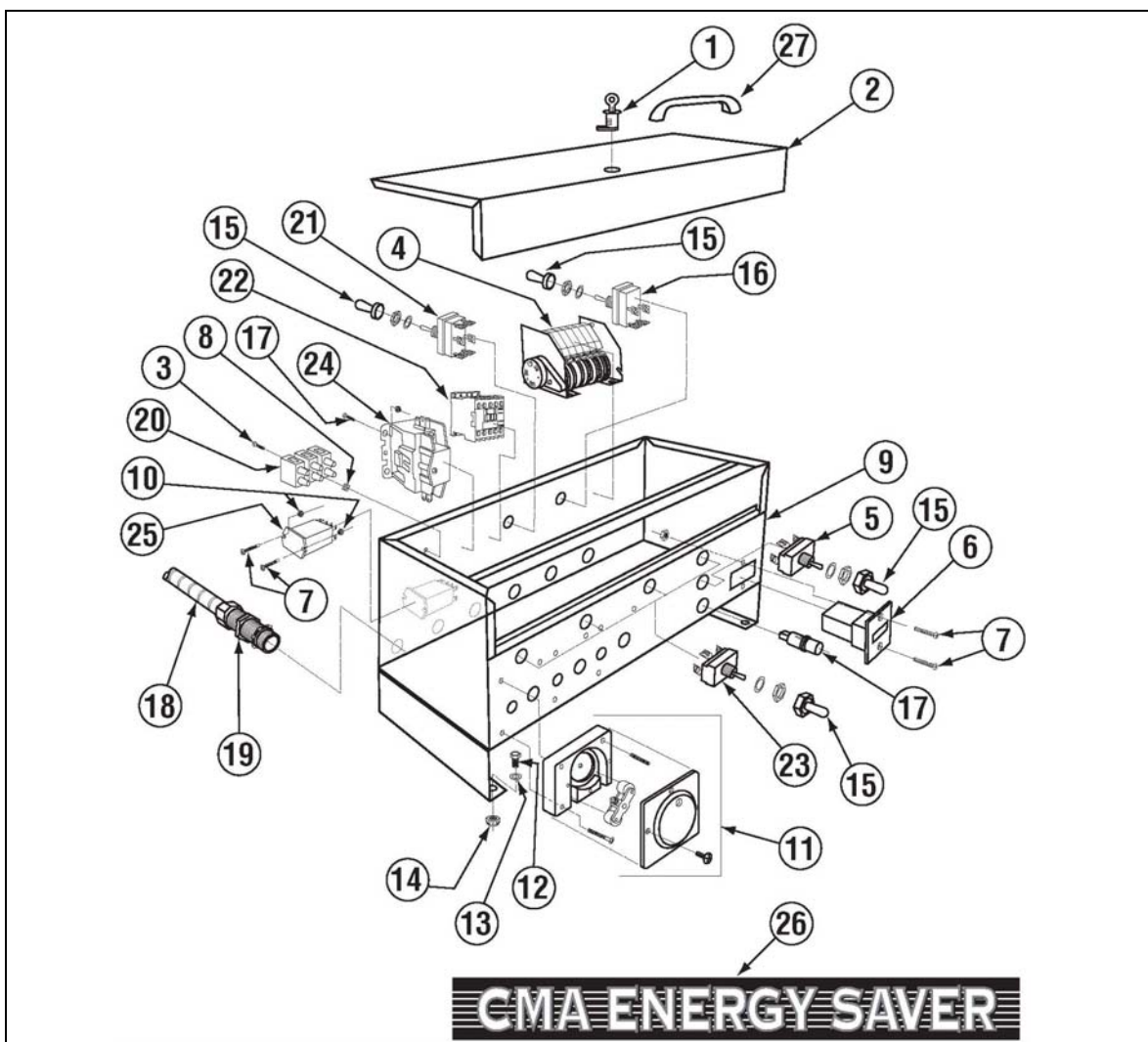

Note: Wiring Harness (V)—Part Number 00414.82—(not shown).

ITEM NO.	NO. REQ'D	P/N	DESCRIPTION
1	1	00449.00	Lock and Key
2	1	01504.17	Control Box Lid
3	5	00911.50	8-32 x 3/8" Pan Head Screw
4	1	00407.83	Timer, 90 Seconds
5	1	03470.01	Toggle Switch, Momentary
6	1	03408.50	Counter (Face Mount)
7	4	00907.00	6-32 x 1/2" SS Pan Head Screw
8	4	00917.00	8-32 PM Nut
9	1	01503.19	Control Box Body
10	4	00916.00	6-32 pm nut
11	3	00415.00	Peristaltic Pump Assembly*
12	4	00906.00	1/2-20 x 1/2" Hex Head Bolt
13	4	00924.00	1/4" SS Washer
14	4	00912.00	1/4-20 Nylon Lock Nut

ITEM NO.	NO. REQ'D	P/N	DESCRIPTION
15	5	00470.10	Toggle Switch Boot
16	1	00471.10	Toggle Switch Off/On 20 Amp
17	2	00406.00	Control Box Light, 120V, 60Hz
18	1	00400.00	Conduit, 3/8" Sealtite
19	3	00401.00	S.T. 3/8" Straight Connector
20	1	00454.10	3-Pole Socket Terminal Block
21	1	00475.70	Toggle Switch, 15 Amp
22	1	13012.15	Contactor 5 kW GL-X 120V
23	4	03470.00	Toggle Switch
24	1	00404.82	Contactor Relay
25	1	00631.00	Ice Cube Relay
26	1	06232.25	CMA Energy Saver Label
27	1	00535.00	Control Box Lid Handle

*See section 1.3.8 Peristaltic Pump Assembly for details

1.3.3. Pump Assembly

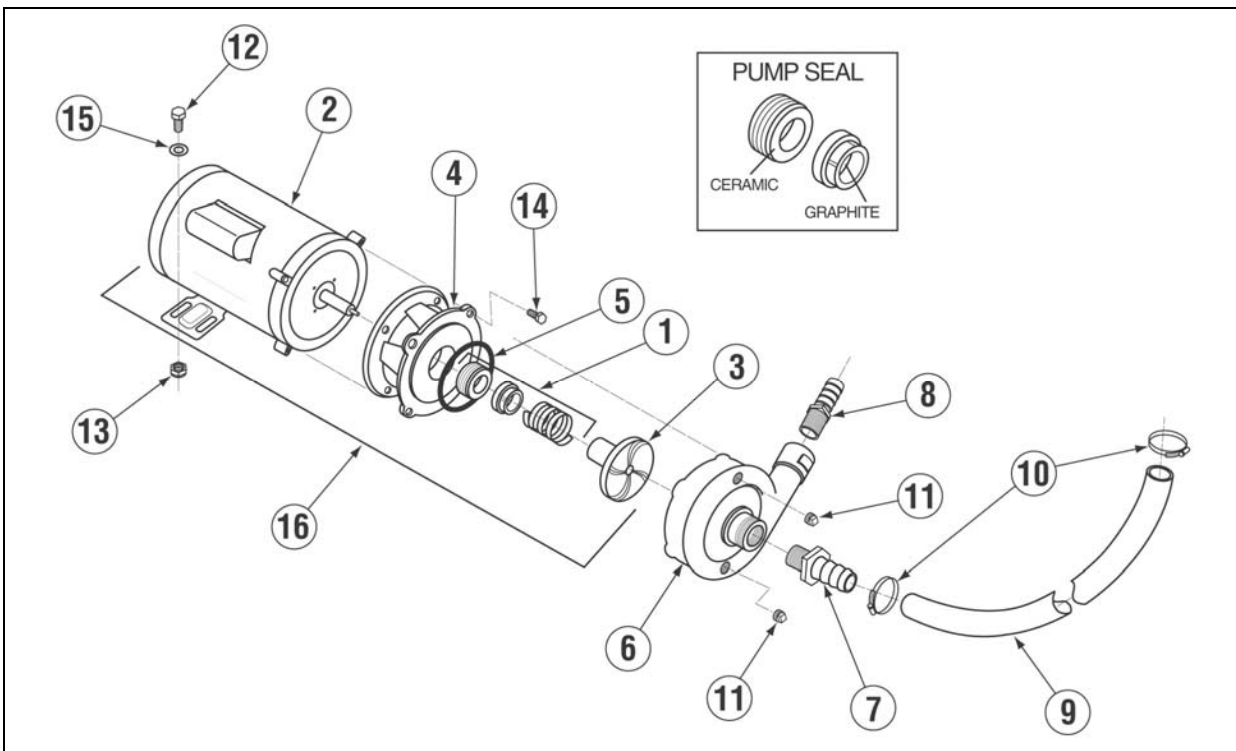

ITEM NO.	NO. REQ'D	P/N	DESCRIPTION
1	1	00206.30	Pump Seal Kit
2	1	00201.00	Pump Motor 1Hp 115/208-230V
3	1	03222.10	Impeller (Universal) Open
4	1	04207.10	Pump Base
5	1	03226.00	Pump O Ring Gasket
6	1	04207.20	Pump Cover
7	1	50302.40	1 1/4 MIP X 1" Barb Fitting
8	1	50302.06	1" MPT X 1" Barb PVC Sch 80

ITEM NO.	NO. REQ'D	P/N	DESCRIPTION
9	1	03108.61	Transfer Hose 1"
10	2	03101.00	Hose Clamp # 16 1"
11	2	00238.00	3/8 Male Plug
12	1	00906.00	1/4-20 X 1/2 Hexhead Bolt
13	1	00912.00	1/4-20 Nylon Lock Nut
14	4	00921.00	3/8-16 X 3/4 SS Hexhead Bolt
15	1	00924.00	1/4 SS Washer
16	1	00200.10	Pump Assy 110/220V 60Hz open

1.3.4. Plumbing System Assembly

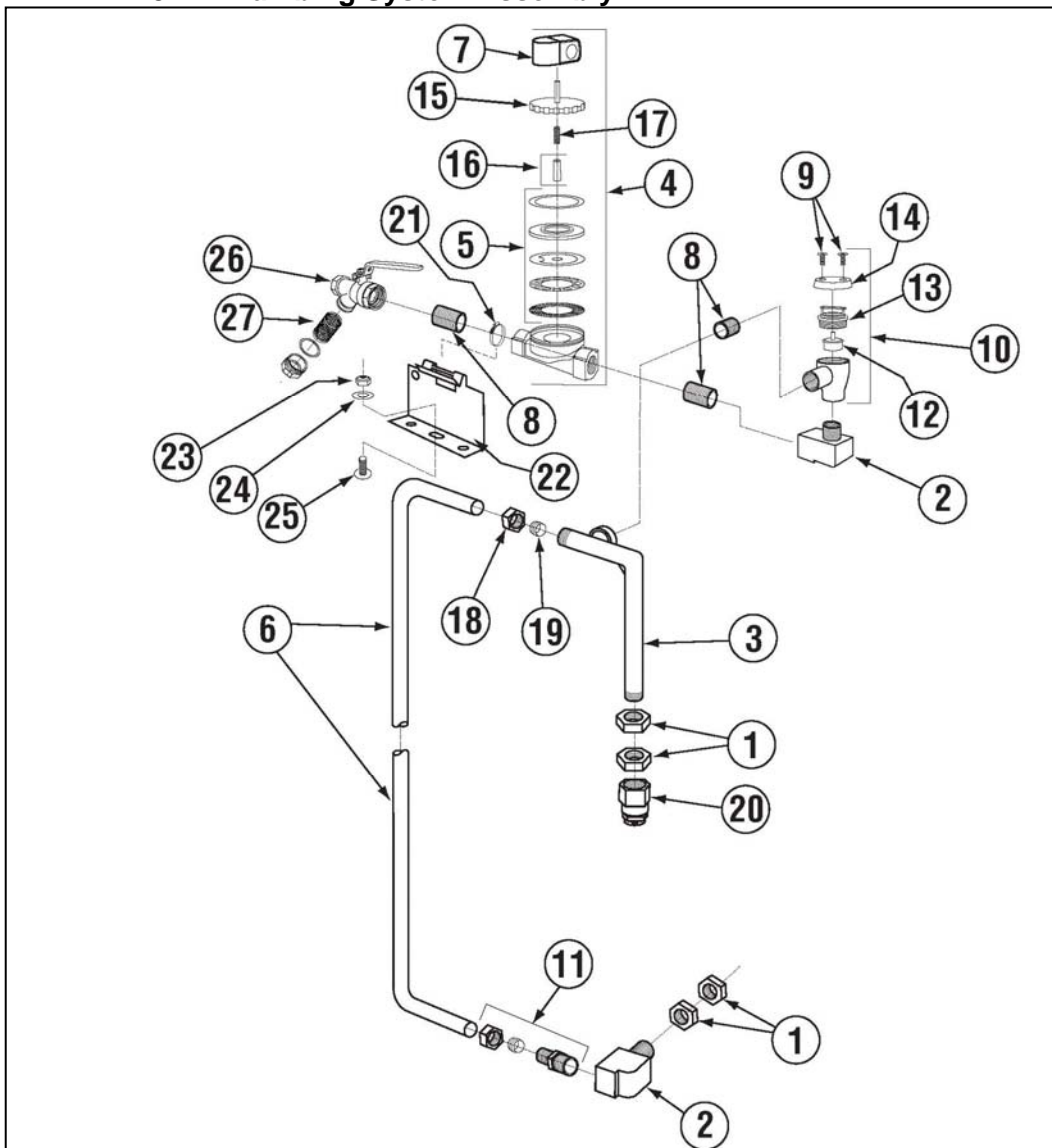

ITEM NO.	NO. REQ'D	P/N	DESCRIPTION
1	4	00721.00	1/2" Jamb Nut
2	2	00745.00	1/2" Street Elbow
3	1	00770.00	Water Inlet Elbow Assy
4	1	03603.10	1/2" Water Solenoid Assembly, J/E*
5	1	00707.00	1/2" Water Solenoid Repair Kit
6	1	00796.20	Flush Tube
7	1	00738.10	Water Solenoid Coil
8	2	00742.00	1/2" x 1-1/2" Brass Nipple
9	2	00421.51	6-32 x 1/4" Pan Head Screw
10	1	03624.00	Vacuum Breaker Assembly, Watts**
11	1	00760.00	5/8" Compression x 1/2" MIP Adapter
12	1	03623.00	1/2" Vacuum Breaker Repair Kit
13	1	03624.25	1/2" Vacuum Breaker Bonnet, Brass
14	1	00739.50	Vacuum Breaker Cap, SS (fits 1/2" or 3/4")

ITEM NO.	NO. REQ'D	P/N	DESCRIPTION
15	1	03603.20	1/2" Water Solenoid Bonnet
16	1	00786.00	Water Solenoid Valve Plunger w/Spring
17	1	00706.10	Valve Plunger, Spring Only
18	1	00770.10	5/8 Compression Fitting Nut
19	1	00770.20	5/8 Compression Fitting Ring
20	1	00748.00	Sprinkler Head
21	1	03101.45	Hose Clamp #4 Size #002 SS
22	1	14508.50	Plumbing Bracket
23	1	03801.00	10-32 Lock Nut
24	2	00924.00	1/4 SS Washer
25	1	00940.50	10-32 x 3/8 Truss Head Screw
26	1	41062.00	1/2 Strainer Ball Valve NPT
27	1	41062.10	1/2 Ball Valve Strainer Only

1.3.5. Spray System Assembly

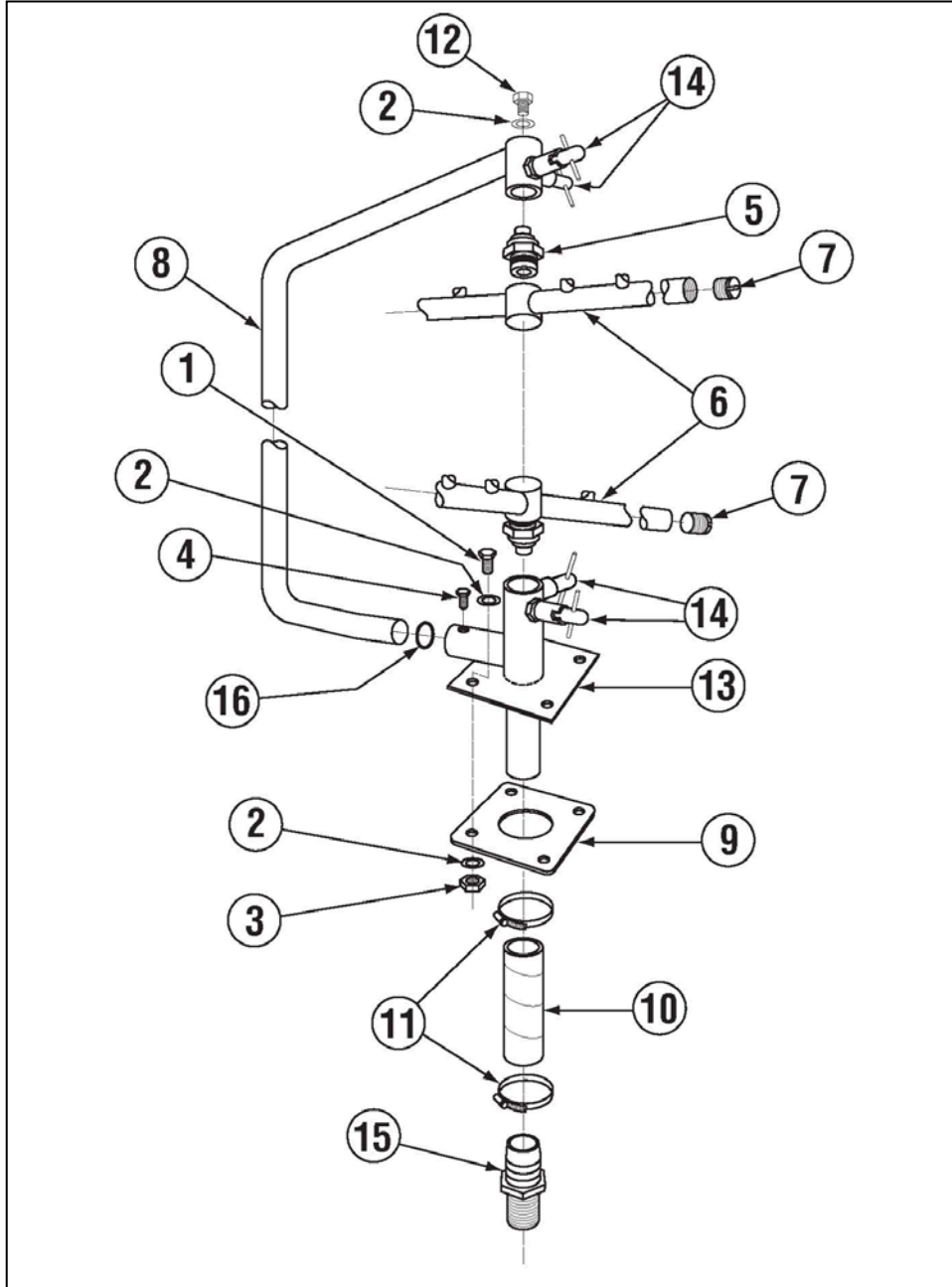

ITEM NO.	NO. REQ'D	P/N	DESCRIPTION
1	4	00914.00	1/4-20 x 3/4" Hex Head Bolt
2	9	00924.00	1/4" SS Washer
3	4	00912.00	1/4-20 Nylon Lock Nut
4	1	00966.10	10-32 x 1/4" Hex Head SS Bolt
5	2	00341.00	Spray Arm Bearing
6	2	00304.07	Spray Arm A/C Series
7	4	00308.50	Spray Arm End Plug SS
8	1	00305.20	Spray Manifold, EST/N- EVA

ITEM NO.	NO. REQ'D	P/N	DESCRIPTION
9	1	04306.00	Square Manifold Gasket
10	1	03108.61	Transfer Hose 1"
11	2	03101.00	Hose Clamp
12	1	00905.82	1/4-20 x 3/8" Truss Head Bolt
13	1	00357.20	Lower Spray Base, N EVA 2007
14	4	0363.50	Spray Base Pull Lock Pin
15	1	50302.06	1" MPT X 1" Barb PVC Schedule 80
16	1	00302.84	Spray Base O-Ring, E-VA

1.3.6. Power Drain Assembly (Prior to 11-2007)

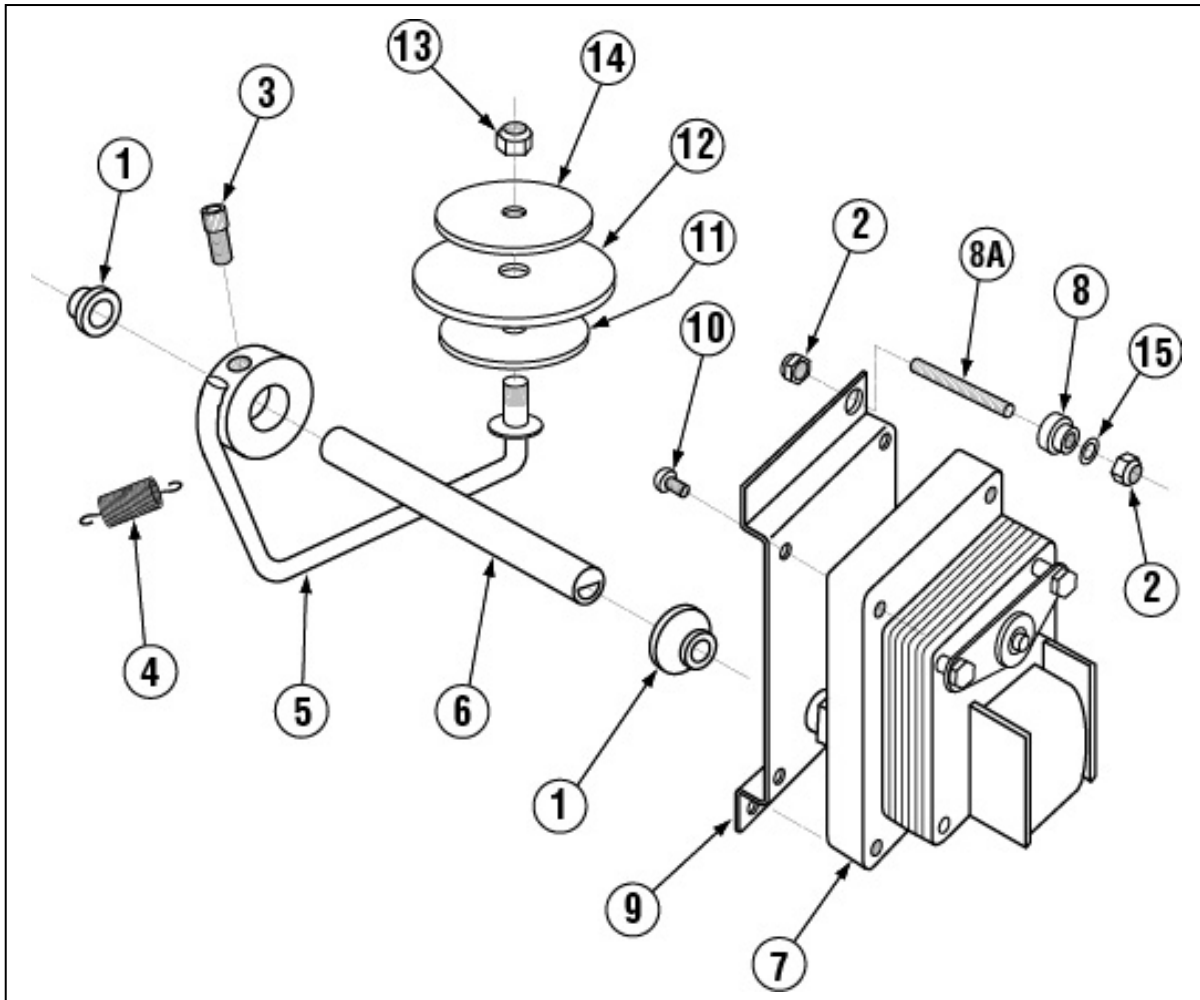

ITEM NO.	NO. REQ'D	P/N	DESCRIPTION
1	2	00938.82	1/2" Drain Bushing, Brass (V)
2	4	03801.00	10-32 Lock Nut
3	1	00906.82	1/4-20 x 5/8" Socket Head Screw
4	1	04103.14	Drain Spring (V)
5	1	00108.83	Drain Actuator Arm (includes #3)
6	1	00109.60	Drain Actuator Shaft (V)
7	1	00104.50	Drain Motor, 120V 60Hz
8	2	00109.40	Shoulder Nut, SS

ITEM NO.	NO. REQ'D	P/N	DESCRIPTION
8A	2	00109.50	10-32 x 1" Stud
9	1	01511.86	Drain Motor Bracket
10	2	00941.00	10-32 x 5/8" Pan Head Screw
11	1	01520.82	Diaphragm Support Disk, 1-1/8"
12	1	00121.60	Drain Diaphragm
13	1	00912.00	1/4-20 Nylon Lock Nut
14	1	01521.82	Diaphragm Support Disk, 2"
15	2	04806.00	#10 Brass Washer

1.3.7. Power Drain Retrofit Kit p/n 00104.95 (11-14-07 to Current)

POWER DRAIN KIT
P/N 00104.95

11-14-07

POWER DRAIN ASSEMBLY INSTRUCTIONS

1. Remove drain lid and power drain cover (see drawing B).
2. Remove hardware securing drain motor. Discard all hardware holding motor in place.
3. Remove and discard motor bracket from motor, but save two (#10) 10-32 screws.
4. Install hardware (#2, #8, #15). Thread two (#8) studs through tank and secure in place with (#2) nylon lock nuts. On the outside of tank install (#15) thin nut onto the (#8) stud and secure. **NOTE:** The (#15) thin nut serves a very important purpose in drain function.
5. From kit install new drain motor bracket to drain motor with two saved (#10) 10-32 screws.
6. Remove drain shaft by loosening (#3) screw on (#5) drain actuator arm. Discard drain shaft.
7. Install the new (#6) drain shaft from the kit and align drain actuator arm to the tank using the (#3) set screw. Make sure the flat side of the (#6) drain shaft has the (#3) set screw tightening against it.
8. Install (#4) drain spring properly on drain shaft and pay particular attention to the positioning of the long arm on spring. The long arm will rest against the top right side of drain motor bracket. (See drawing A). Install short end of spring into slot of drain shaft. (See figure C).
9. Align the shaft of the (#7) drain motor with (#6) drain actuator shaft slot as motor is placed into position. Drain motor bracket with motor attached is secured to (#8) studs using (#2) and (#17) nylon lock nuts and washers.
10. Grease the drain shaft and (#1) drain bushings. Replace drain lid and drain cover. When drain kit has been completed, energize drain several times and check its function. **NOTE:** Remove electrical spade connectors from wires leading to drain motor and replace with two (#16) flag terminals supplied in drain kit. This will allow proper clearance between drain lid and flag terminals.

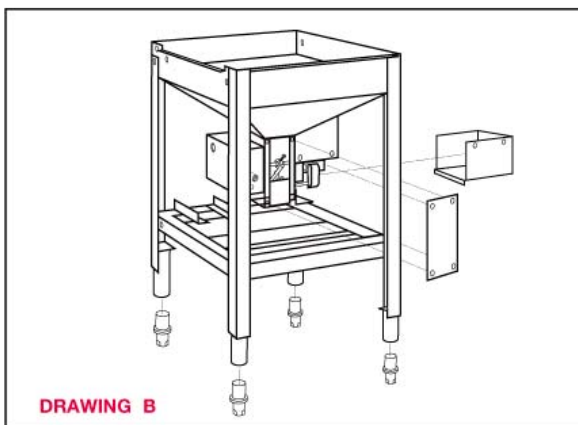
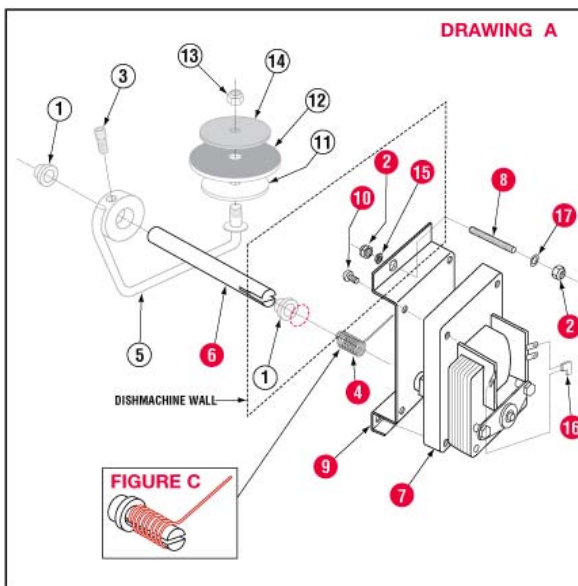

ITEM NO.	NO. REQ'D	DESCRIPTION
1	2	P/N 00938.82 Drain Bushing
2	2	P/N 03801.00 10/32 Nylon Lock Nut
3	1	P/N 00906.82 Socket Head Screw
4	1	P/N 04103.14 Drain Spring
5	1	P/N 00108.82 Drain Actuator Arm
6	1	P/N 00109.60 Drain Shaft EVA
7	1	P/N 00104.50 Drain Motor 120V
8	2	P/N 00109.50 Drain Mounting Studs
9	1	P/N 01511.86 Drain Motor Bracket
10	4	P/N 00941.00 10-32X5/8 PanHead Screw
11	1	P/N 01520.82 Support Disk
12	1	P/N 00121.60 Drain Diaphragm
13	1	P/N 00912.00 Nylon Nut
14	1	P/N 01521.82 Two Inch Support Disk
15	1	P/N 03801.20 10/32 Thin Nut
16	2	P/N 00557.20 Flag Terminal 14-16 GAUGE
17	2	P/N 00924.00 SS Washer

NOTE: Items in bold are included in the Power Drain Kit. "All items in power drain kit must be used for drain to operate properly"



12700 Knott Avenue
Garden Grove, CA 92841
For Questions Call: 800-854-6417
714-898-6781 • FAX 714-895-2141
www.cmadishmachines.com

1.3.8. Peristaltic Pump Assembly

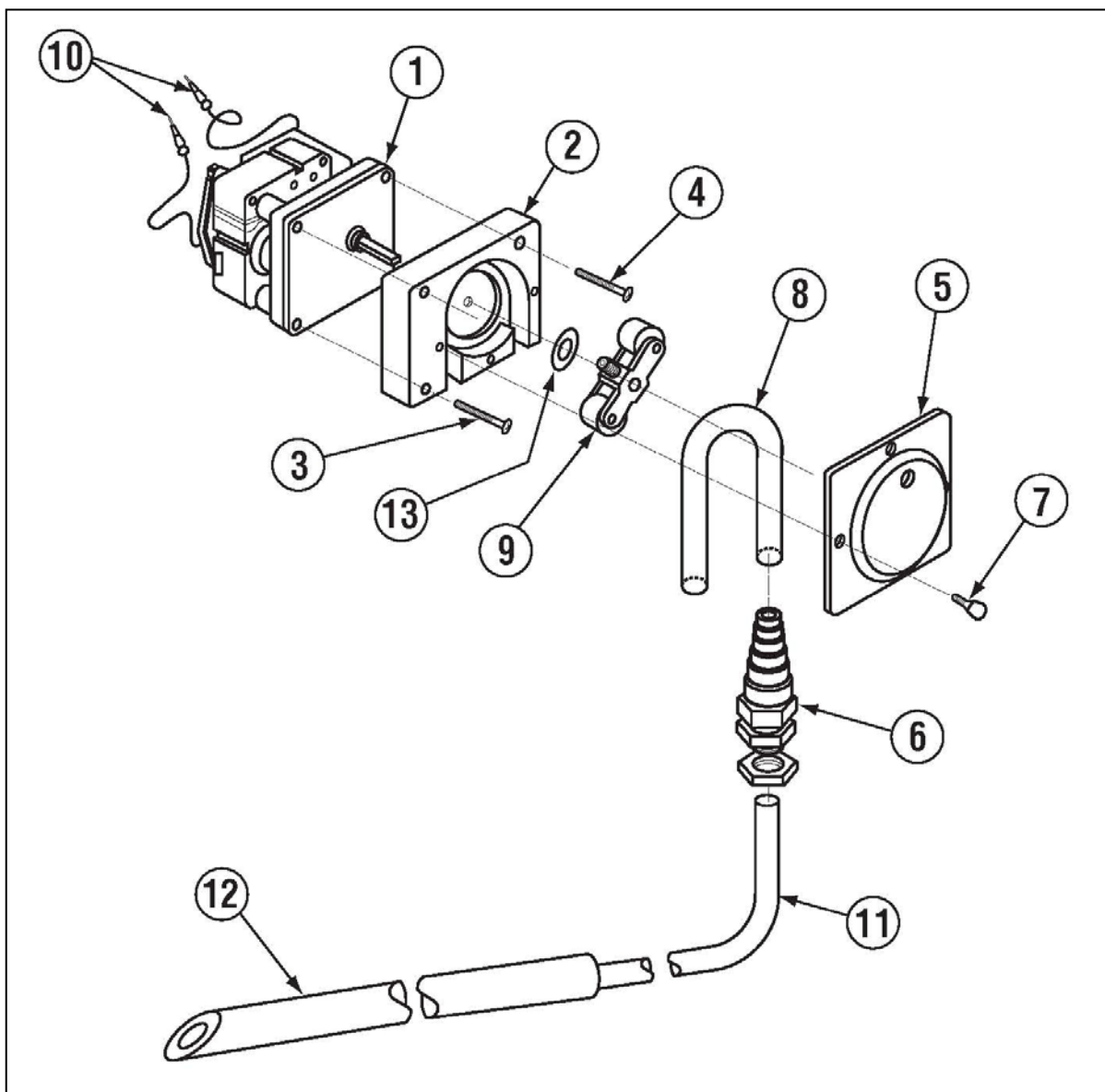

ITEM NO.	NO. REQ'D	P/N	DESCRIPTION
1	1	00416.00	Peristaltic Pump Motor
2	1	00417.10	Peristaltic Pump Block
3	2	00919.00	10-32 x 1-1/2" Pan Head Screw
4	1	00918.10	10-32 x 1-1/2" Fillister Head Screw
5	1	00418.00	Peristaltic Pump Block Cover
6	1	03415.50	Flex-Tight Fitting
7	4	00911.00	8-32 x 1/2" Pan Head Screw

ITEM NO.	NO. REQ'D	P/N	DESCRIPTION
8	1	2257.00	Squeeze Tube
9	1	00419.00	2-Bearing Rotor Assembly
10	2	00448.00	Barrel Connector, Male
11	1	00425.51	Chemical Tubing, Blue
	1	00425.53	Chemical Tubing, Red
	1	00425.54	Chemical Tubing, White
12	3	00443.00	Tube Stiffener
13	1	00422.50	Rotor Spacer

1.3.9. Sustainer Heater (Optional)

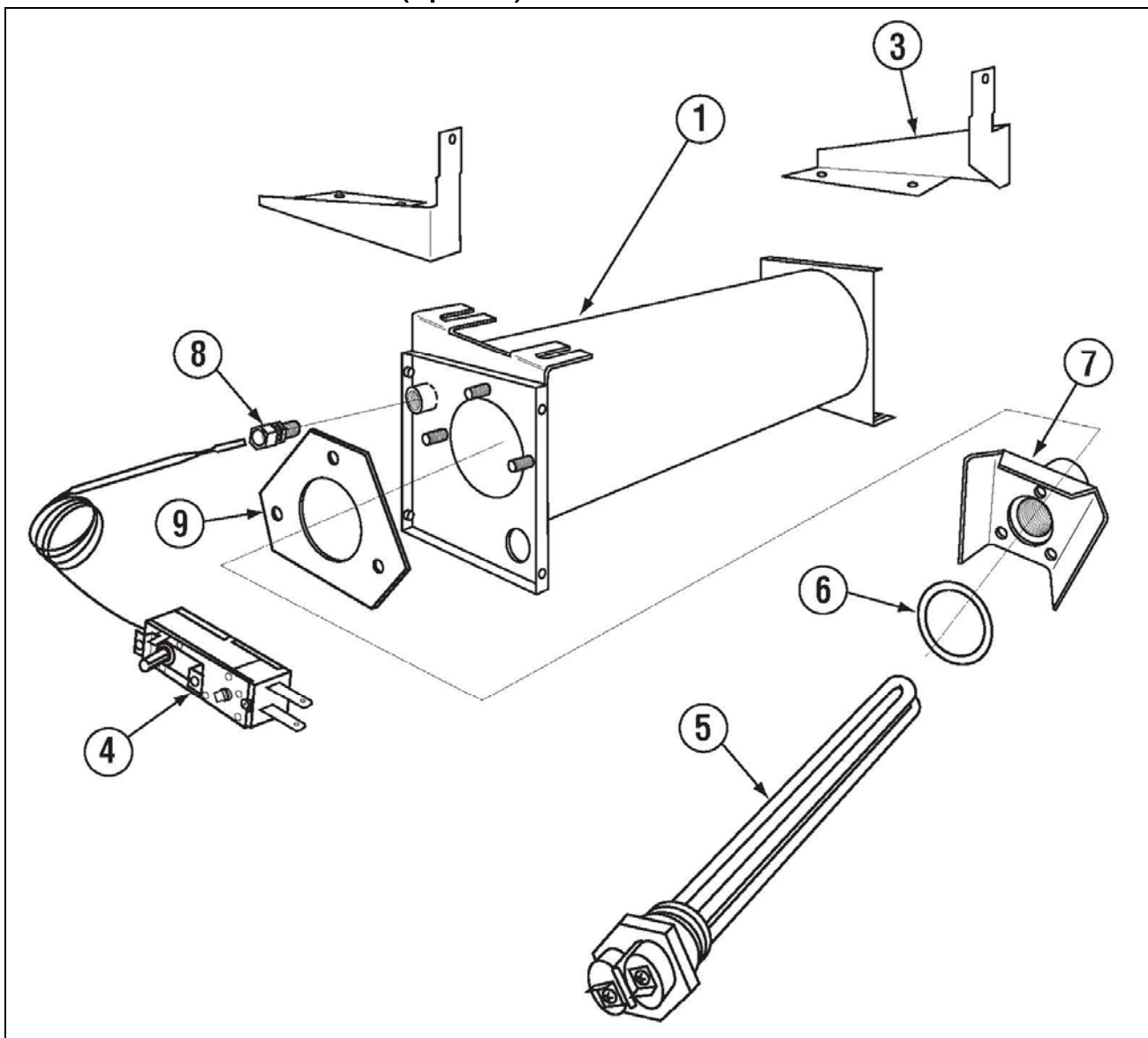

ITEM NO.	NO. REQ'D	P/N	DESCRIPTION
1	1	17550.20	Booster Tank
2	1	17604.06	EST Ventless Front Heater Bracket
3	1	17605.00	EST Ventless Back Heater Bracket
4	1	13417.94	Thermostat
5	1	15417.30	Screw Plug Heater 1.5kW, 115V
6	1	00703.00	O-Ring Gasket
7	1	17550.30	EST FL Booster Tank Adapter
8	1	40116.00	1/4 Comp x 1/4 MIP Fitting
9	1	15518.13	Sustainer Heater Gasket