



# MODEL L-1X & L-1X16

## PARTS MANUAL

Rev 1.20 09-23-25



**CMA DISHMACHINES**  
**17707 VALLEY VIEW AVENUE**  
**CERRITOS, CALIFORNIA 90703**

**800-854-6417**

FAX 714-895-2141

[www.cmadishmachines.com](http://www.cmadishmachines.com)

[Buy Parts](#)

# TABLE OF CONTENTS

## MODEL CMA-L-1X & L-1X16

<b>1. PARTS MANUAL .....</b>	<b>3</b>
1.1. INITIAL PARTS KIT (P/N 4001.00).....	3
1.2. EXPLODED VIEW DRAWINGS.....	4
1.2.1. Cabinet Assembly .....	4
1.2.2. Cabinet Assembly (Effective 06/2007).....	5
1.2.3. L-1X Door Assembly (Old Style) .....	6
1.2.4. L-1X/L-1X16 Door Assembly.....	7
1.2.5. Spray System Assembly.....	8
1.2.6. NST S/S Pump Assembly (Effective November 2015).....	9
1.2.7. S/S Pump Assembly (Effective August 2009).....	10
1.2.8. Pump Assembly.....	11
1.2.9. Plumbing System Assembly (Effective June 2013).....	12
1.2.10. Plumbing System Assembly.....	13
1.2.11. Drain System Assembly.....	14
1.2.12. Control Box .....	15
1.2.13. Control Box (Effective 06/2007).....	16
1.2.14. Peristaltic Pump Assembly .....	17
1.2.15. Drain Valve .....	18
1.2.16. Drain Valve (Effective January 2011).....	19
1.2.17. Optional Sani Alarm.....	20

## 1. Parts Manual

### 1.1. Initial Parts Kit (P/N 4001.00)

P/N	DESCRIPTION	Qty
<a href="#">00200.40</a>	SS Pump w/115v Motor Assy.	1
<a href="#">00206.70</a>	Pump Seal Kit New	1
<a href="#">00208.40</a>	Slip Joint Nut O Ring Gasket Buna	1
<a href="#">00307.10</a>	Spray Arm Assy. L-1C, L-1X, L-1X16 Complete	1
<a href="#">00404.82</a>	Motor Contactor Relay	1
<a href="#">00411.00</a>	Micro Switch	1
<a href="#">00415.00</a>	Peristaltic Pump Assembly, 120V/60Hz	1
<a href="#">00421.40</a>	Start/Fill Rocker Switch Amber	1
<a href="#">00425.21</a>	Chemical Tubing Blue (50 Ft/ Coil)	1
<a href="#">00425.23</a>	Chemical Tubing Red (50 Ft / Coil)	1
<a href="#">00425.24</a>	Chemical Tubing White (50 Ft / Coil).	1
<a href="#">00501.00</a>	Timer Motor, 2-Minute	1
<a href="#">00707.00</a>	1/2 Water Solenoid Repair Kit JE	1
<a href="#">00715.00</a>	1/2 Ball Check Valve	1
<a href="#">00738.10</a>	Solenoid Coil JE 115V (3/4 & 1/2)	1
<a href="#">02257.00</a>	Squeeze Tube 8" Norprene	1
<a href="#">02257.22</a>	Squeeze Tube 22" Norprene For L-1X	1
<a href="#">03202.00</a>	Thermometer (Capillary)	1
<a href="#">03415.00</a>	Chemical Tube Bulkhead	1
<a href="#">03415.20</a>	Sani Bulkhead Fitting Assy.	1
<a href="#">03481.00</a>	Drain Rocker Switch (GL-X/L-1X)	1
<a href="#">03485.00</a>	Switch Guard (Undercounter Units)	1
<a href="#">04110.00</a>	SS L-1C, L-1X, L-1X16, GLX Drain Screen	1
<a href="#">04113.00</a>	Drain Valve 115V New Style	1
<a href="#">04517.15</a>	Door Stop (Parallel)	1
<a href="#">15524.00</a>	Power Rocker Switch Red 125V	1

**NOTE:** CMA recommends that the initial parts kit be kept on hand as a back up supply of critical parts in the event your machine should require emergency service. All the parts included in this kit are unique to the L-1X and L-1X16 dishmachine.

## 1.2. Exploded View Drawings

### 1.2.1. Cabinet Assembly

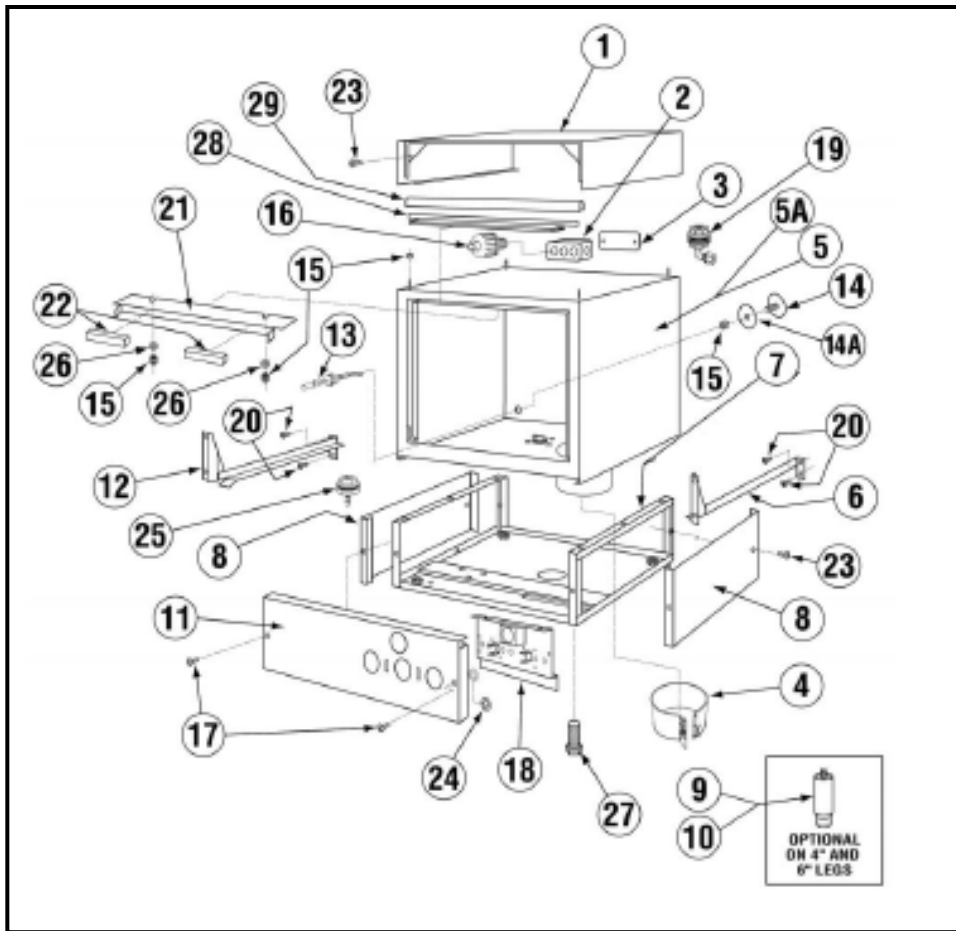

ITEM NO.	NO. REQ'D	P/N	DESCRIPTION	ITEM NO.	NO. REQ'D	P/N	DESCRIPTION
1	1	<a href="#">04903.73</a>	L-1X Top Cover	14A	1	<a href="#">00752.60</a>	Hole Stopper Gasket
2	1	<a href="#">03420.00</a>	Undercounter Bell Box	15	9	<a href="#">00912.00</a>	Nylon Lock Nut 1/4"-20
3	1	<a href="#">03423.00</a>	Undercounter Bell Box Cover	16	1	<a href="#">00401.10</a>	St-1/2 Straight Connector
4	1	<a href="#">04109.11</a>	Band Sump Heater 115V	17	2	<a href="#">00941.00</a>	10-32 x 5/8" Pan head Screw
5	1	<a href="#">04901.60</a>	Stainless Steel Body L-1X	18	1	<a href="#">04914.78</a>	Peri Pump Mount w/ Prime Switch
5A	1	<a href="#">04901.73</a>	Stainless Steel Body L-1X16	19	2	<a href="#">03415.00</a>	Chemical Tube Bulkhead
6	1	<a href="#">04911.60</a>	Tray Track (RH)	20	4	<a href="#">00914.00</a>	1/4-20 x 3/4" Hex Head Bolt
7	1	<a href="#">04902.80</a>	Stand "Open Style" L-1X, L-1X16	21	1	<a href="#">14558.00</a>	Body Magnet Holder
8	2	<a href="#">04902.84</a>	Panels for Open Style Stand	22	2	<a href="#">00557.80</a>	Door Magnet
9	4	<a href="#">01146.50</a>	4" Leg (Optional)	23	10	<a href="#">00940.50</a>	10-32 x 3/8" Truss Head Screw
10	4	<a href="#">01146.00</a>	6" Leg (Optional)	24	2	<a href="#">03816.00</a>	Nylon Retaining Washer
11	1	<a href="#">04915.78</a>	Peri Pump Panel w/ Prime Switch	25	1	<a href="#">03415.60</a>	Chemical Tube Bulkhead Barbed
12	1	<a href="#">04912.60</a>	Tray Track (LH)	26	2	<a href="#">00924.00</a>	Washer SS 1/4"
13	1	<a href="#">13463.10</a>	Liquid Level Switch	27	4	<a href="#">01310.60</a>	Leg Adjusters
14	1	<a href="#">01513.60</a>	Hole Stopper	28	1	<a href="#">14506.45</a>	Gasket Bracket
				29	1	<a href="#">14506.50</a>	Door Gasket

Thermometer [03202.00](#) not shown

Top Support Bracket [04903.79](#) not shown

## 1.2.2. Cabinet Assembly (Effective 06/2007)

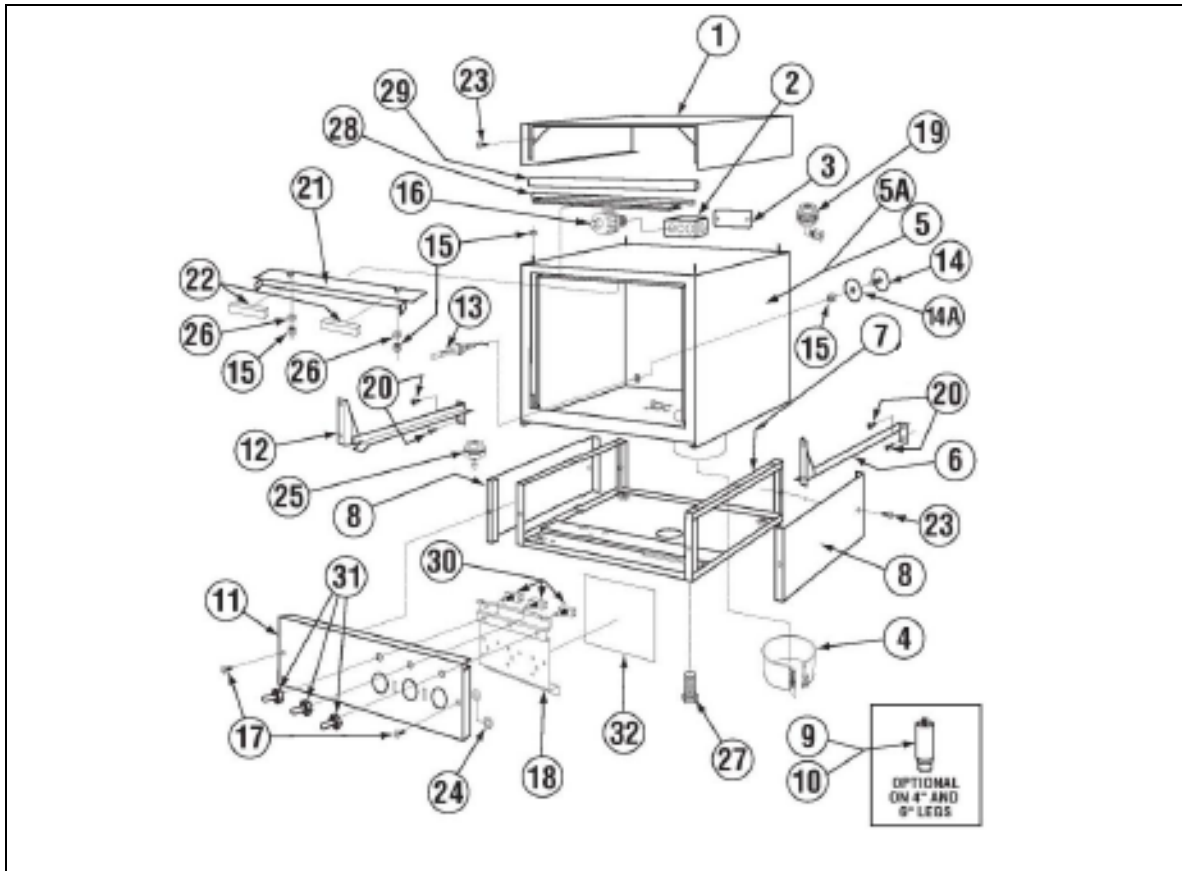

ITEM NO.	NO. REQ'D	P/N	DESCRIPTION
1	1	<a href="#">04903.73</a>	L-1X Top Cover
2	1	03420.00	Undercounter Bell Box
3	1	<a href="#">03423.00</a>	Undercounter Bell Box Cover
4	1	<a href="#">04109.11</a>	Band Sump Heater 115V
5	1	<a href="#">04901.60</a>	Stainless Steel Body L-1X
5A	1	<a href="#">04901.73</a>	Stainless Steel Body L-1X16
6	1	<a href="#">04911.60</a>	Tray Track (RH)
7	1	<a href="#">04902.80</a>	Stand "Open Style" L-1X,L-1X16
8	2	<a href="#">04902.84</a>	Panels for Open Style Stand
9	4	<a href="#">01146.50</a>	4" Legs (Optional)
10	4	<a href="#">01146.00</a>	6" Legs (Optional)
11	1	<a href="#">04915.78</a>	Peri Pump Panel w/ Prime Switch
12	1	<a href="#">04912.60</a>	Tray Track (LH)
13	1	<a href="#">13463.10</a>	Liquid Level Switch
14	1	<a href="#">01513.60</a>	Hole Stopper
14A	1	<a href="#">00752.60</a>	Hole Stopper Gasket
15	9	<a href="#">00912.00</a>	Nylon Lock Nut 1/4"-20

ITEM NO.	NO. REQ'D	P/N	DESCRIPTION
16	1	00401.10	St-1/2 Straight Connector
17	2	<a href="#">00941.00</a>	10-32 x 5/8" Pan head Screw
18	1	<a href="#">04914.78</a>	Peri Pump Mount w/ Prime Switch
19	2	<a href="#">03415.00</a>	Chemical Tube Bulkhead
20	4	<a href="#">00914.00</a>	1/4-20 x 3/4" Hex Head Bolt
21	1	<a href="#">14558.00</a>	Body Magnet Holder
22	2	<a href="#">00557.80</a>	Door Magnet
23	10	<a href="#">00940.50</a>	10-32 x 3/8" Truss Head Screw
24	2	<a href="#">03816.00</a>	Nylon Retaining Washer
25	1	<a href="#">03415.60</a>	Chemical Tube Bulkhead Barbed
26	2	<a href="#">00924.00</a>	Washer SS 1/4"
27	4	<a href="#">01310.60</a>	Leg Adjusters
28	1	<a href="#">14506.45</a>	Gasket Bracket
29	1	<a href="#">14506.50</a>	Door Gasket
30	3	<a href="#">03475.00</a>	Prime Switches
31	3	<a href="#">03476.00</a>	Prime Switch Boots
32	1	03705.23	Peri Pump Motor Splash Shield

**1.2.3. L-1X Door Assembly (Old Style)**

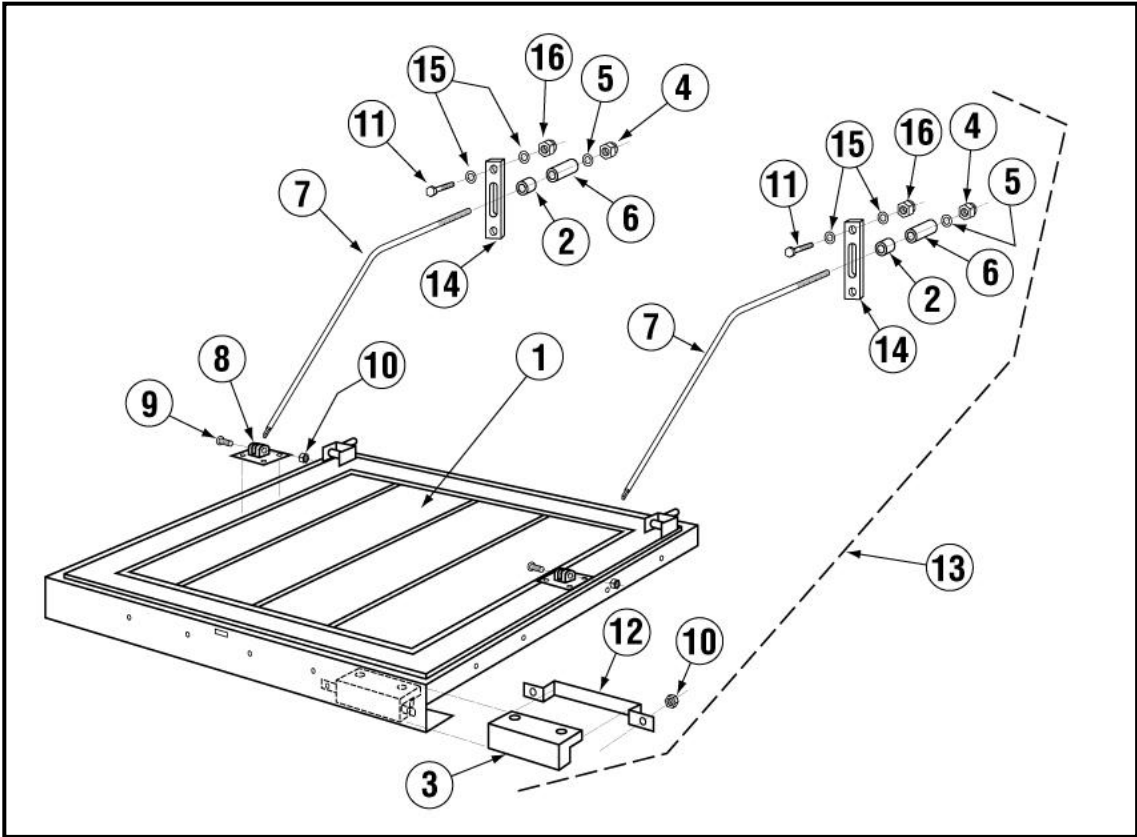

ITEM NO.	NO. REQ'D	P/N	DESCRIPTION
1	1	04906.90	Inner & Outer Panel Assy.
2	2	00605.30	Door Rod Spacer
3	1	00557.60	Reed Switch Magnet
4	2	13805.00	5/6" 18 Lock Nut
5	2	00926.00	5/15" SS Washer
6	2	04517.15	Door Stop (Silicone) Parallel
7	2	04918.10	Door Support Rod Angled
8	1	04916.00	Door Clevis
9	3	13825.00	#8 32 x 1" Pan Head Screw
10	2	00927.00	#8-32 Lock Nut
11	4	00914.10	Bolt 1/4"-20 x 5/8"
12	1	00558.61	Reed Switch Magnet Bracket
13*	1	04509.20	Door Complete
14	2	04517.62	Door Support Rod Block
15	8	00924.00	Washer 1/4" SS
16	4	00912.00	Lock Nut Nylon 1/4"-20

\*Excludes Item #2, 11, 14, 15 & 16

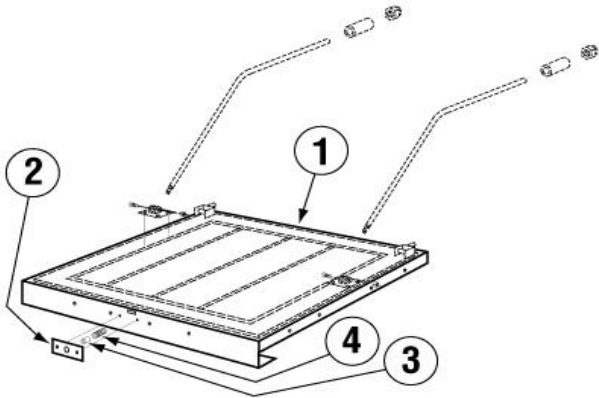

ITEM NO.	NO. REQ'D	P/N	DESCRIPTION
1	1	04509.10	L1-C Door Complete
2	1	04510.00	L-1C Door Catch Plate
3	1	04511.00	L-1C Catch Hemi-Ball SS
4	1	04512.00	L-1C Catch Ball Spring

## 1.2.4. L-1X/L-1X16 Door Assembly

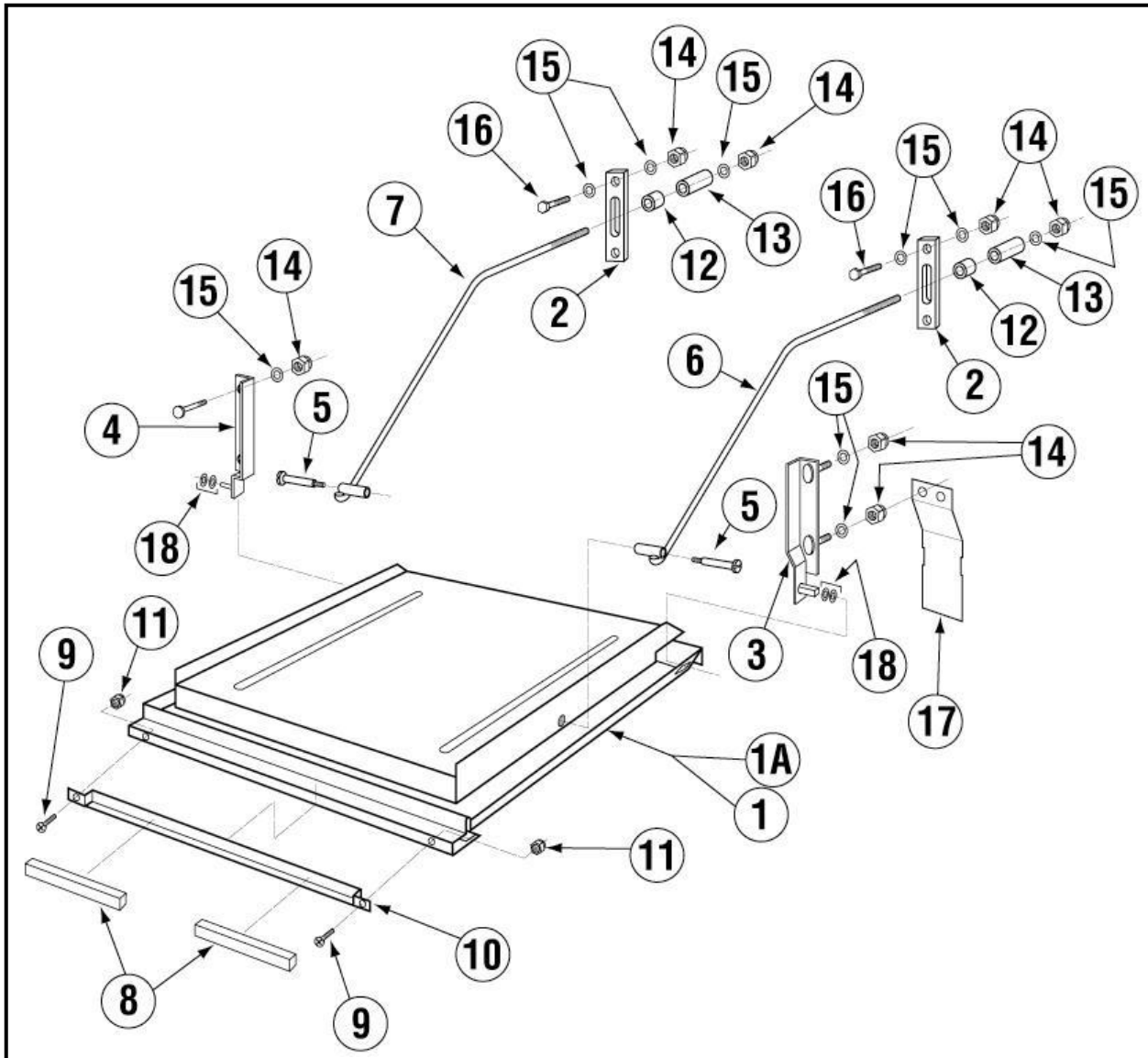

ITEM NO.	NO. REQ'D	P/N	DESCRIPTION
1	1	<a href="#">04907.90</a>	L-1X Door (New 7-2002)
1A	1	<a href="#">14506.00</a>	Door for L-1X16
2	2	<a href="#">04517.60</a>	Door Support Rod Block
3	1	<a href="#">14570.00</a>	Door Hinge (RH)
4	1	<a href="#">14570.50</a>	Door Hinge (LR)
5	2	<a href="#">04919.00</a>	Door Rod Screw Pin for Door
6	1	<a href="#">04918.60</a>	Door Support Rod Right
7	1	<a href="#">04919.50</a>	Door Support Rod Left
8	3	<a href="#">00557.80</a>	Door Magnet
9	2	<a href="#">00970.60</a>	6 32 x 1/2" Flathead Screw

ITEM NO.	NO. REQ'D	P/N	DESCRIPTION
10	1	<a href="#">14558.61</a>	Door Magnet Holder
11	2	<a href="#">00965.00</a>	06-32 Lock Nut
12	2	<a href="#">00605.30</a>	Door Rod Spacer
13	2	<a href="#">04517.15</a>	Door Stop (Parallel)
14	10	<a href="#">00912.00</a>	1/4"-20 Nylon Lock Nut
15	14	<a href="#">00924.00</a>	1/4" SS Washer
16	4	<a href="#">00914.10</a>	1/4"-20 x 5/8" Hex Head Bolt
17	2	<a href="#">14518.00</a>	Splash Guard
18	4	<a href="#">00924.00</a>	1/4 SS Washer

1.2.5. Spray System Assembly

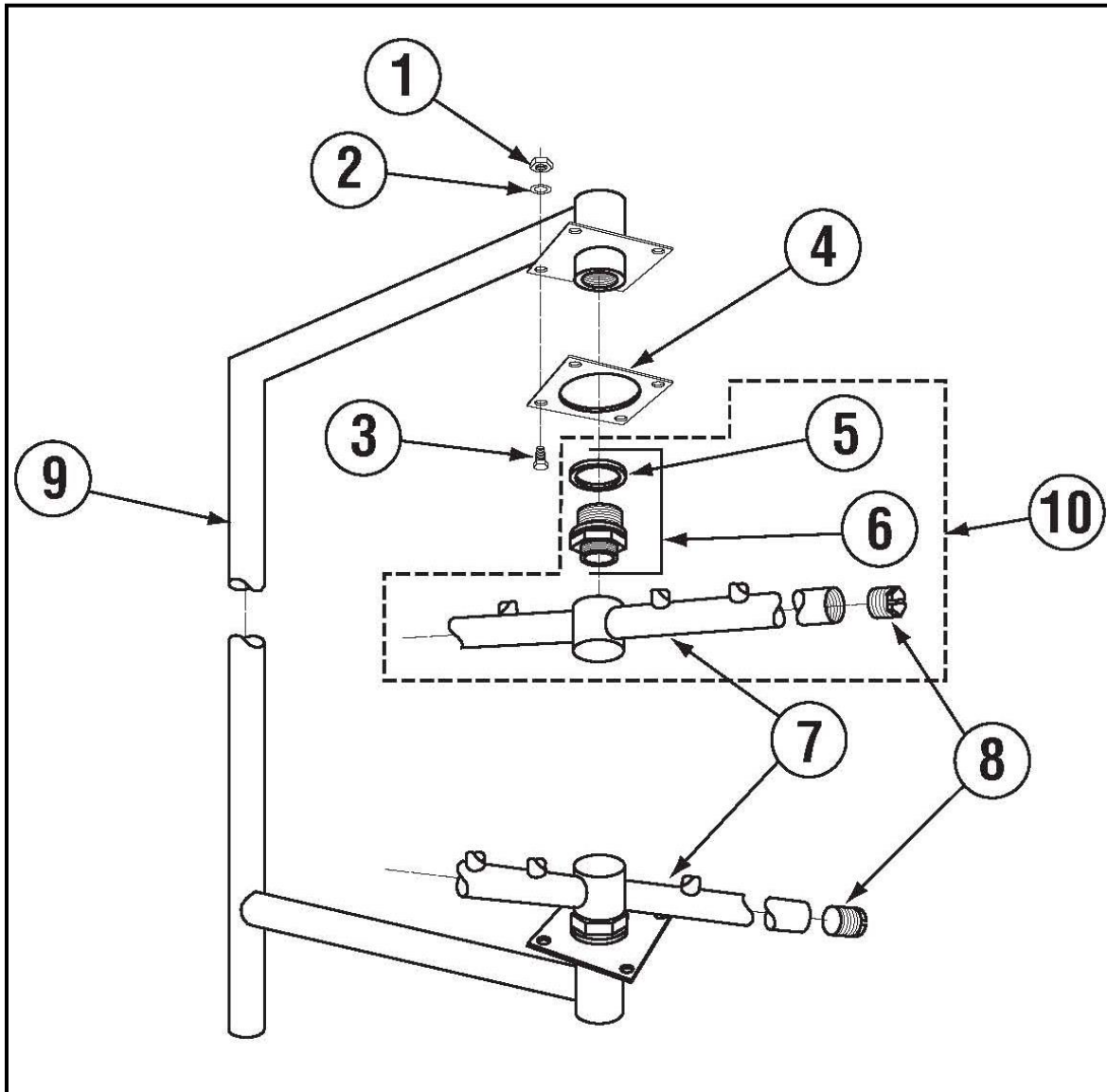

ITEM NO.	NO. REQ'D	P/N	DESCRIPTION
1	8	00912.00	1/4"-20 Nylon Lock Nut
2	16	00924.00	1/4" SS Washer
3	8	00929.00	1/4"-20 x 3/4" Truss Head Bolt
4	2	04306.00	Square Manifold Gasket
5	2	04305.10	Silicon Gasket
6	2	04303.00	L-1X Spray Arm Bearing
7	2	00304.04	Spray Arm
8	4	00308.50	Spray Arm End Plug
9	1	04301.00	L-1X Spray Manifold
9A	1	04301.60	L1-X16 Spray Manifold
10	1	00307.10	Spray Arm Assy.

**1.2.6. NST S/S Pump Assembly (Effective November 2015)**

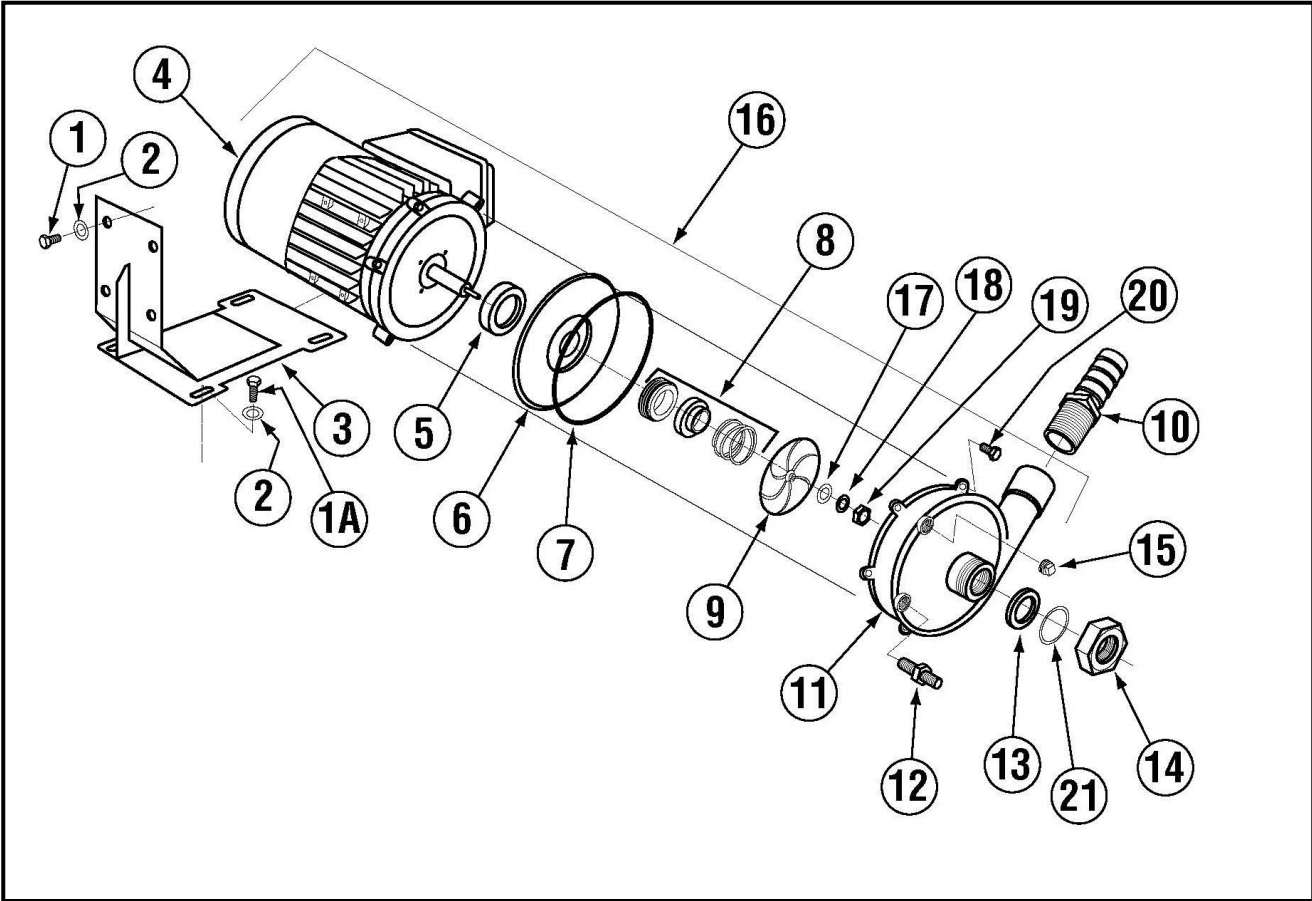

ITEM NO.	NO. REQ'D	P/N	DESCRIPTION
1	3	00908.00	5/16"-18 x 5/8" SS Hexhead Bolt
2	3	00926.00	5/16" SS Washer
3	1	00200.44	NST SS Pump Motor Holder "L"
4	1	00201.65	SS Wash Pump Motor 115v
5	1	00201.96	Slinger Washer Cone Shape
6	1	03224.60	SS Pump Backplate
7	1	03226.70	Volute O-Ring For SS Pump
8	1	00206.70	SS Pump Seal Kit
9*	1	03222.61	NST SS Pump Impeller
10	1	50302.10	1" MPT x 1" Barb Brass
11	1	04206.76	NST SS Pump Cover

ITEM NO.	NO. REQ'D	P/N	DESCRIPTION
12	1	00214.50	1/2" Comp x 3/8" MIP Adapter
13	1	00208.40	Slip Joint Nut O Ring Buna
14	1	00207.00	Slip Joint Nut 1 1/2 x 1 1/4
15	1	00238.00	3/8" Male Plug
16*	1	00200.43	NST Assy. Includes 4,5,6,7,8,9, 11
17	1	03222.74	Flat Washer 8 mm
18	1	03222.72	Shaft Nut Lock Washer 8mm
19	1	13809.70	SS Pump Seal Shaft Nut 8mm
20	6	00914.70	Socket Head Screw 10 mm
21	1	00208.21	Slip Joint Nut Friction Ring Plastic

\* Effective May, 2018 item 9 – 00203.41 NST SS Pump Impeller  
 Item 16 – 00200.43 NST Pump Assy. Includes 4-11.

**1.2.7. S/S Pump Assembly (Effective August 2009)**

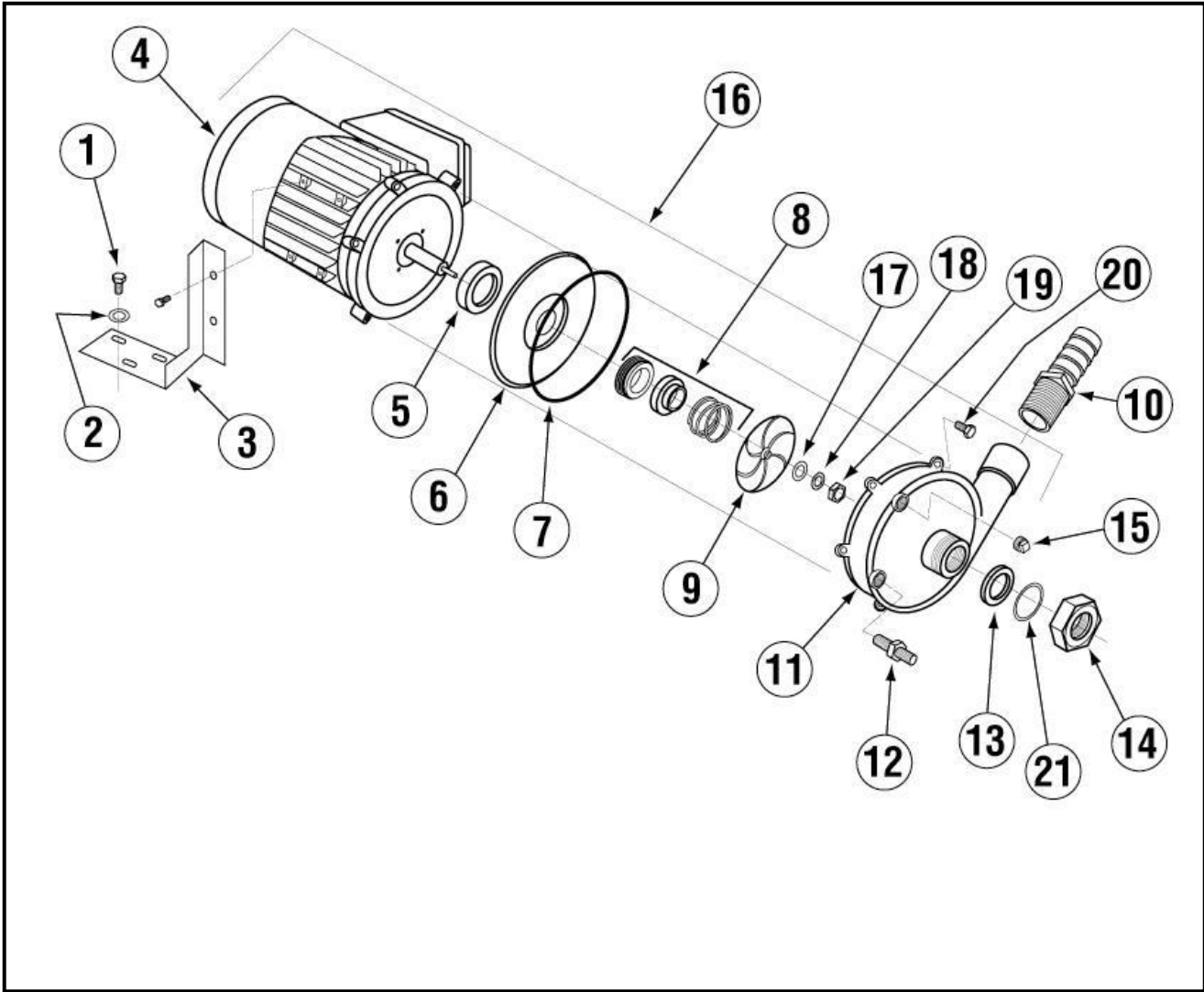

ITEM NO.	NO. REQ'D	P/N	DESCRIPTION
1	3	<a href="#">00908.00</a>	5/16"-18 x 5/8" SS Hexhead Bolt
2	3	<a href="#">00926.00</a>	5/16" SS Washer
3	1	<a href="#">00200.78</a>	SS Pump Motor Holder "L"
4	1	<a href="#">00201.65</a>	SS Wash Pump Motor 115v
5	1	<a href="#">00201.96</a>	Slinger Washer Cone Shape
6	1	<a href="#">03224.60</a>	SS Pump Backplate
7	1	<a href="#">03226.70</a>	Volute O-Ring For SS Pump
8	1	<a href="#">00206.70</a>	SS Pump Seal Kit
9	1	<a href="#">03222.60</a>	SS Pump Impeller
10	1	<a href="#">50302.10</a>	1" MPT x 1" Barb Brass
11	1	<a href="#">04206.75</a>	SS Pump Cover

ITEM NO.	NO. REQ'D	P/N	DESCRIPTION
12	1	<a href="#">00214.50</a>	1/2" Comp x 3/8" MIP Adapter
13	1	<a href="#">00208.40</a>	Slip Joint Nut O Ring Buna
14	1	<a href="#">00207.00</a>	Slip Joint Nut 1 1/2 x 1 1/4
15	1	<a href="#">00238.00</a>	3/8" Male Plug
16	1	<a href="#">00200.75</a>	Includes Items 4,5,6,7,8,9,and 11
17	1	<a href="#">03222.74</a>	Flat Washer 8 mm
18	1	<a href="#">03222.72</a>	Shaft Nut Lock Washer 8mm
19	1	<a href="#">13809.70</a>	SS Pump Seal Shaft Nut 8mm
20	6	<a href="#">00914.70</a>	Socket Head Screw 10 mm
21	1	<a href="#">00208.21</a>	Slip Joint Nut Friction Ring Plastic

## 1.2.8. Pump Assembly

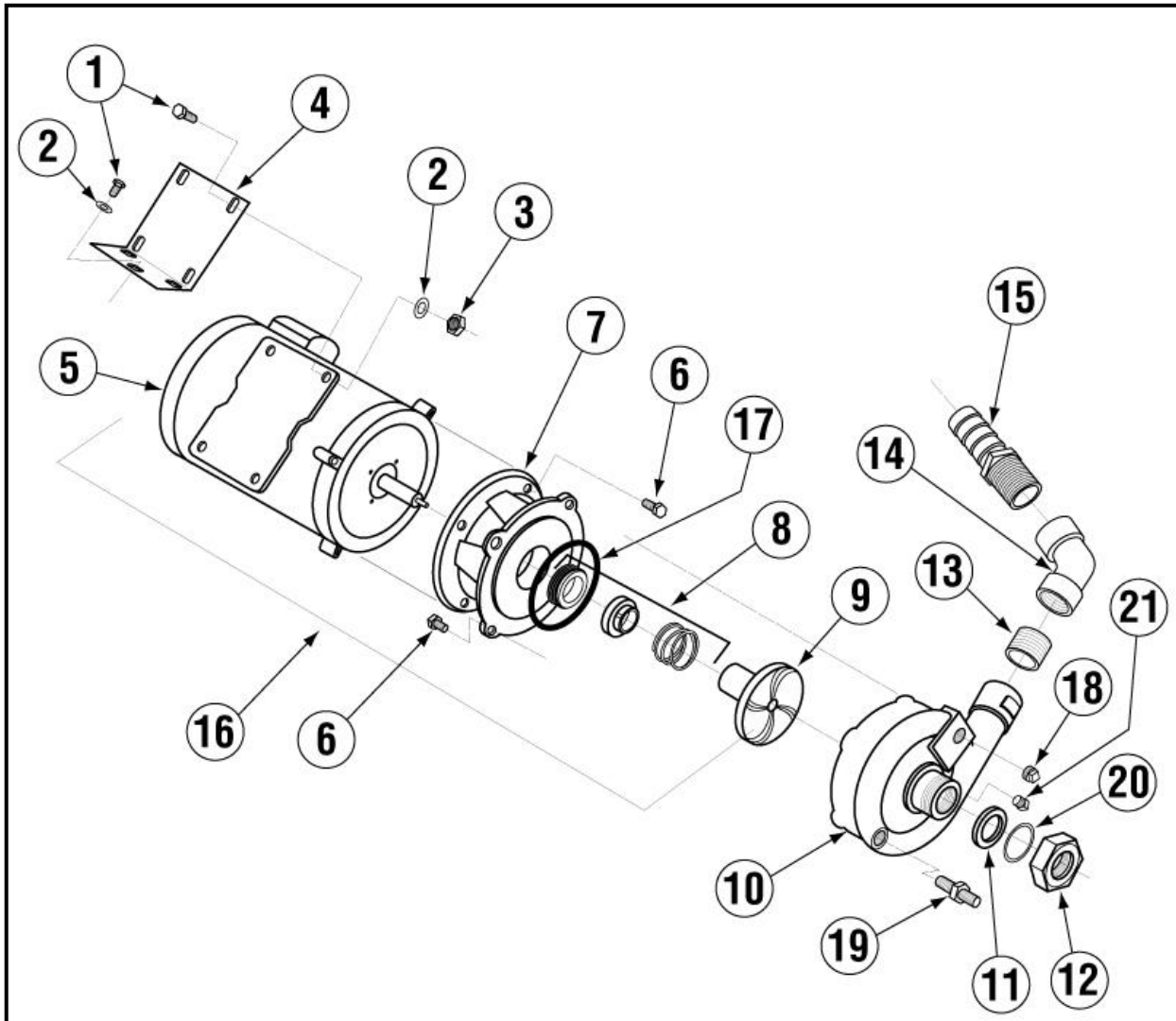

ITEM NO.	NO. REQ'D	P/N	DESCRIPTION
1	7	00908.00	5/16"-18 x 5/8" SS Hexhead Bolt
2	7	00926.00	5/16" SS Washer
3	4	13805.00	5/16"-18 Nylon Lock Nut
4	1	04909.00	Motor Mount
5	1	00201.00	Water Pump Motor 1 HP
6	8	00921.00	3/8"-16 x 3/4" Hex Bolt
7	1	04207.10	Pump Base (Mount)
8	1	00206.30	Pump Seal Kit New (11/07)
9	1	03222.05	Impeller (universal) open
10	1	04207.20	Pump cover
11	1	00208.40	Slip Joint Nut O Ring Gasket Buna

ITEM NO.	NO. REQ'D	P/N	DESCRIPTION
12	1	04204.00	Compression Nut 2.5"
13	1	14004.00	1" close Nipple SS
14	1	04601.00	45 Degree Elbow FIP x FIP
15	1	50302.06	1" MIP x 1" Barb PVC
16	1	00200.10	Includes Items 5, 6, 7, 8 and 9
17	1	03226.00	Pump "O" Ring Gasket
18	1	00238.00	3/8" Male Plug
19	1	00214.50	1/2" Comp x 3/8" MIP Adapter
20	1	00208.21	Slip Joint Nut Friction Ring Plastic
21	1	03232.00	1/8" Male Plug

**1.2.9. Plumbing System Assembly (Effective June 2013)**

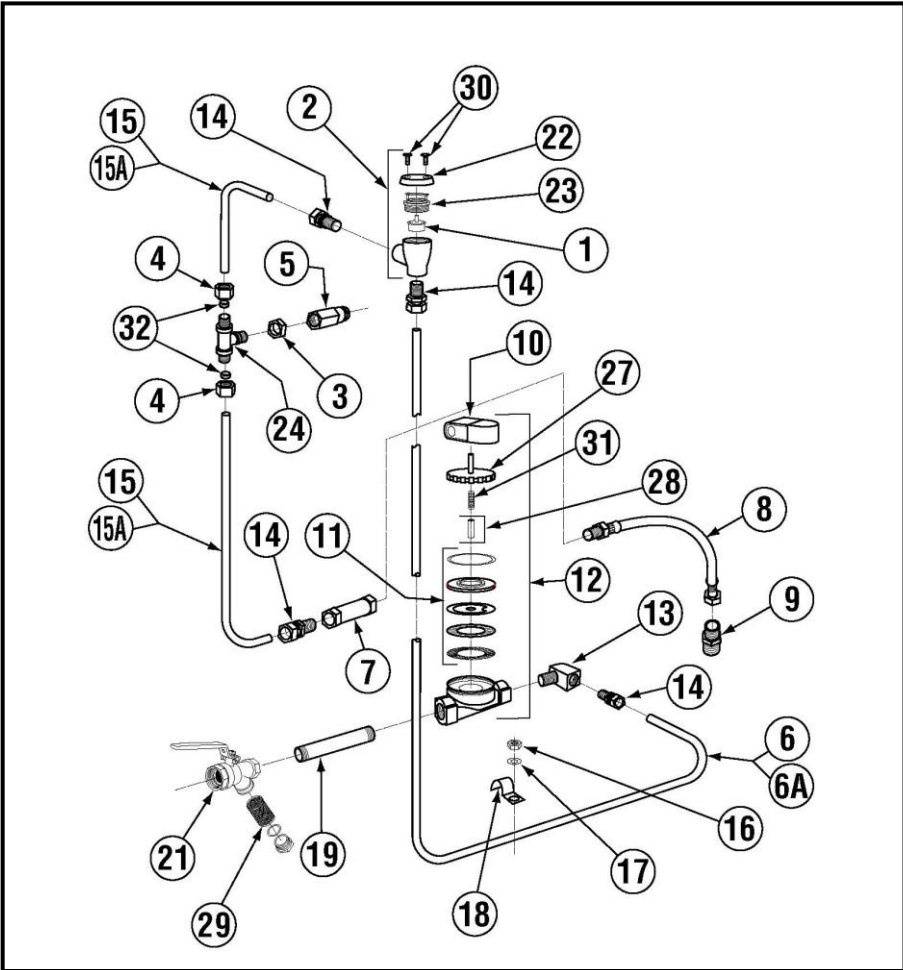

ITEM NO.	NO. REQ'D	P/N	DESCRIPTION
1	1	03623.00	1/2" Vac. Brkr Repair Kit – WATTS
2	1	03624.00	1/2" Vacuum Breaker – WATTS
3	2	00721.00	1/2" Jamb Nut
4	2	00770.10	5/8 Compression Fitting Nut
5	1	00748.00	1/2" Sprinkler Head Assembly
6	1	04605.00	L-1X "U" Tube
6A	1	04605.60	L-1X 16"U" Tube
7	1	00715.00	Ball Check Valve
8	1	00798.00	SS Braided Hose
9	1	00214.50	1/2" Comp x 3/8" MIP FTG
10	4	00738.10	Water Solenoid Coil J/E
11	1	00707.00	1/2" Water Solenoid Repair Kit J/E
12	1	03603.10	1/2" Water Solenoid Valve J/E
13	1	00745.00	1/2" 90 Degree Street Elbow
14	6	00760.00	5/8" Comp. X 1/2" MIP Adapter
15	1	04606.00	L-1X "L" Tube
15A	1	04606.60	L-1X16 "L" Tube

ITEM NO.	NO. REQ'D	P/N	DESCRIPTION
16	1	00915.00	1/4"-20 Hex Nut
17	1	00924.00	1/4" SS Washer
18	1	00725.50	1/2" Plumbing Strap
19	1	00747.10	Nipple Brass 1/2" x 5"
20	1	03602.50	1/2" Y Strainer – Optional
21	1	41062.00	1/2 Strainer Ball Valve
22	1	00739.50	Vacuum Breaker Cap SS
23	1	03624.25	Vacuum Breaker Bonnet Brass
24	1	00743.12	Tee 1/2C x 1/2C x 1/2 Male
25	1	00742.00	Nipple Brass 1/2" x 1-1/2" (Optional)
26	1	00744.00	Nipple Brass 1/2" x 2" (Optional)
27	1	03603.20	1/2" Water Solenoid Bonnet
28	1	00786.00	Water Solenoid Valve Plunger
29	1	41062.10	^ 1/2 Ball Valve Strainer Only
30	2	00970.40	6-32 x 1/4" Phillips Pan Head Screw
31	1	00706.10	Plunger Spring Only
32	2	00770.20	5/8 Compression Fitting Ring

**1.2.10. Plumbing System Assembly**

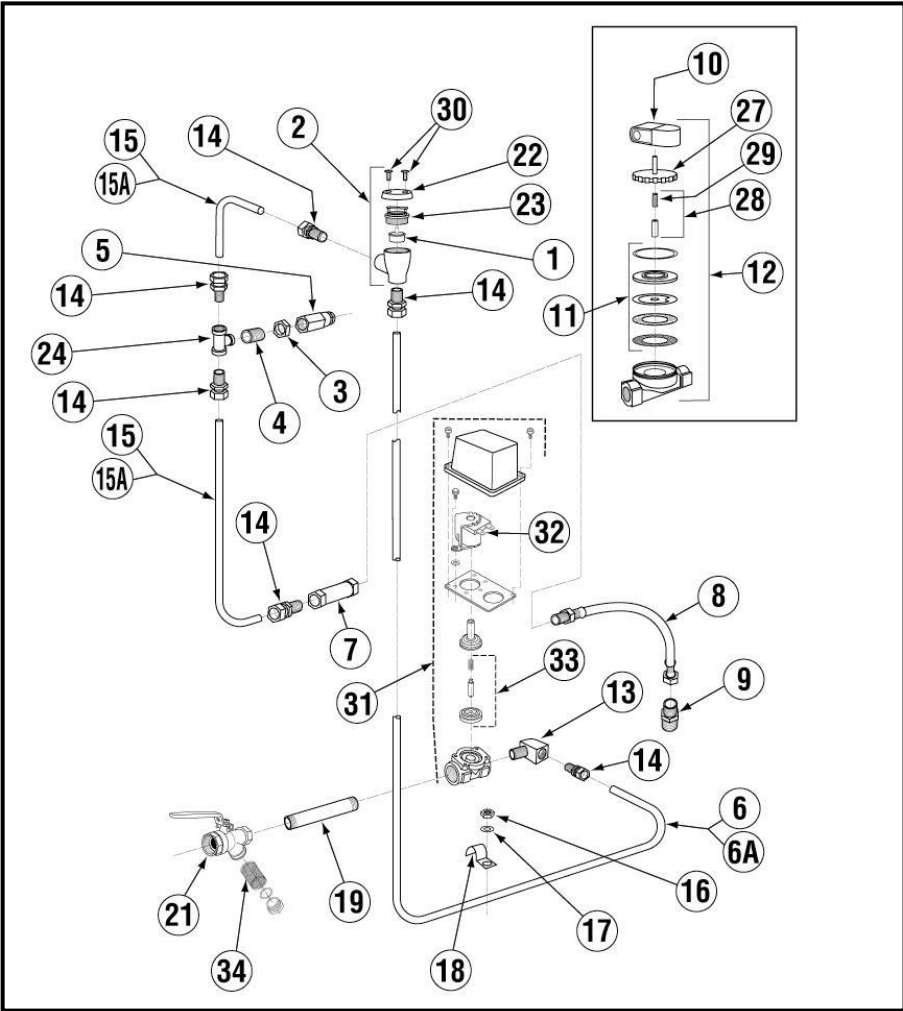

ITEM NO.	NO. REQ'D	P/N	DESCRIPTION
1	1	<a href="#">03623.00</a>	1/2" Vac. Brkr Repair Kit – WATTS
2	1	<a href="#">03624.00</a>	1/2" Vacuum Breaker – WATTS
3	2	<a href="#">00721.00</a>	1/2" Jamb Nut
4	1	<a href="#">03614.00</a>	1/2" Brass (Close) Nipple
5	1	<a href="#">00748.00</a>	1/2" Sprinkler Head Assembly
6	1	<a href="#">04605.00</a>	L-1X "U" Tube
6A	1	<a href="#">04605.60</a>	L-1X 16"U" Tube
7	1	<a href="#">00715.00</a>	Ball Check Valve
8	1	<a href="#">00798.00</a>	SS Braided Hose
9	1	<a href="#">00214.50</a>	1/2" Comp x 3/8" MIP FTG
10	4	<a href="#">00738.10</a>	Water Solenoid Coil J/E
11	1	<a href="#">00707.00</a>	1/2" Water Solenoid Repair Kit J/E
12	1	<a href="#">03603.10</a>	1/2" Water Solenoid Valve J/E
13	1	<a href="#">00745.00</a>	1/2" 90 Degree Street Elbow
14	6	<a href="#">00760.00</a>	5/8" Comp. X 1/2" MIP Adapter
15	1	<a href="#">04606.00</a>	L-1X "L" Tube
15A	1	<a href="#">04606.60</a>	L-1X16 "L" Tube
16	1	<a href="#">00915.00</a>	1/4"-20 Hex Nut

ITEM NO.	NO. REQ'D	P/N	DESCRIPTION
17	1	<a href="#">00924.00</a>	1/4" SS Washer
18	1	<a href="#">00725.50</a>	1/2" Plumbing Strap
19	1	<a href="#">00747.10</a>	Nipple Brass 1/2" x 5"
20	1	<a href="#">03602.50</a>	1/2" Y Strainer – Optional
21	1	<a href="#">41062.00</a>	1/2 Strainer Ball Valve
22	1	<a href="#">00739.50</a>	Vacuum Breaker Cap SS
23	1	<a href="#">03624.25</a>	Vacuum Breaker Bonnet Brass
24	1	<a href="#">00743.11</a>	^1/2 Tee FxFxF SS
25	1	<a href="#">00742.00</a>	Nipple Brass 1/2" x 1-1/2" (Optional)
26	1	<a href="#">00744.00</a>	Nipple Brass 1/2" x 2" (Optional)
27	1	<a href="#">03603.20</a>	1/2" Water Solenoid Bonnet
28	1	<a href="#">00786.00</a>	Water Solenoid Valve Plunger
29	1	<a href="#">00706.10</a>	Plunger Spring Only
30	2	<a href="#">00970.40</a>	6-32 x 1/4" Phillips Pan Head Screw
31	1	<a href="#">03604.00</a>	SS Water Solenoid Valve 1/2"
32	1	<a href="#">41015.60</a>	1/4 Water Solenoid Coil Only 110V
33	1	<a href="#">03604.30</a>	Dema Valve Repair Kit 1/2"
34	1	<a href="#">41062.10</a>	^ 1/2 Ball Valve Strainer Only

## 1.2.11. Drain System Assembly

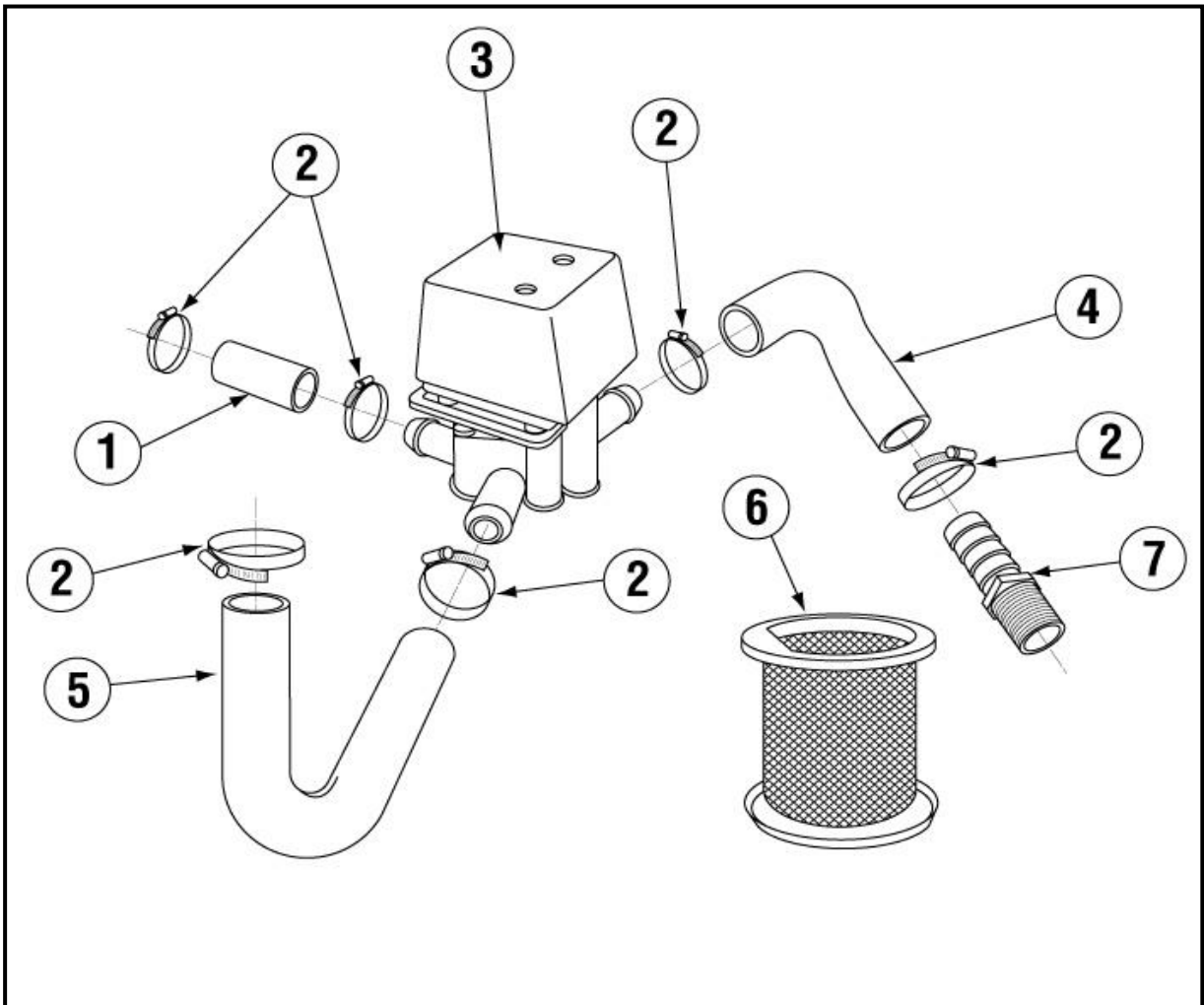

ITEM NO.	NO. REQ'D	P/N	DESCRIPTION
1	2	<a href="#">04105.00</a>	Pump Hose 6.5"
2	8	<a href="#">03101.00</a>	1" Hose Clamp #16
3	1	<a href="#">04103.00</a>	Drain Valve 115V
		<a href="#">04113.00</a>	Drain Valve 115V New Style
4	1	<a href="#">03108.51</a>	1" Goose Neck Drain Hose
5	1	<a href="#">03109.00</a>	Drain Hose 90DEG 1"
6	1	<a href="#">04110.00</a>	L-1X Drain Screen SS
7	1	<a href="#">50302.06</a>	1" MIP x 1" Barb PVC

## 1.2.12. Control Box

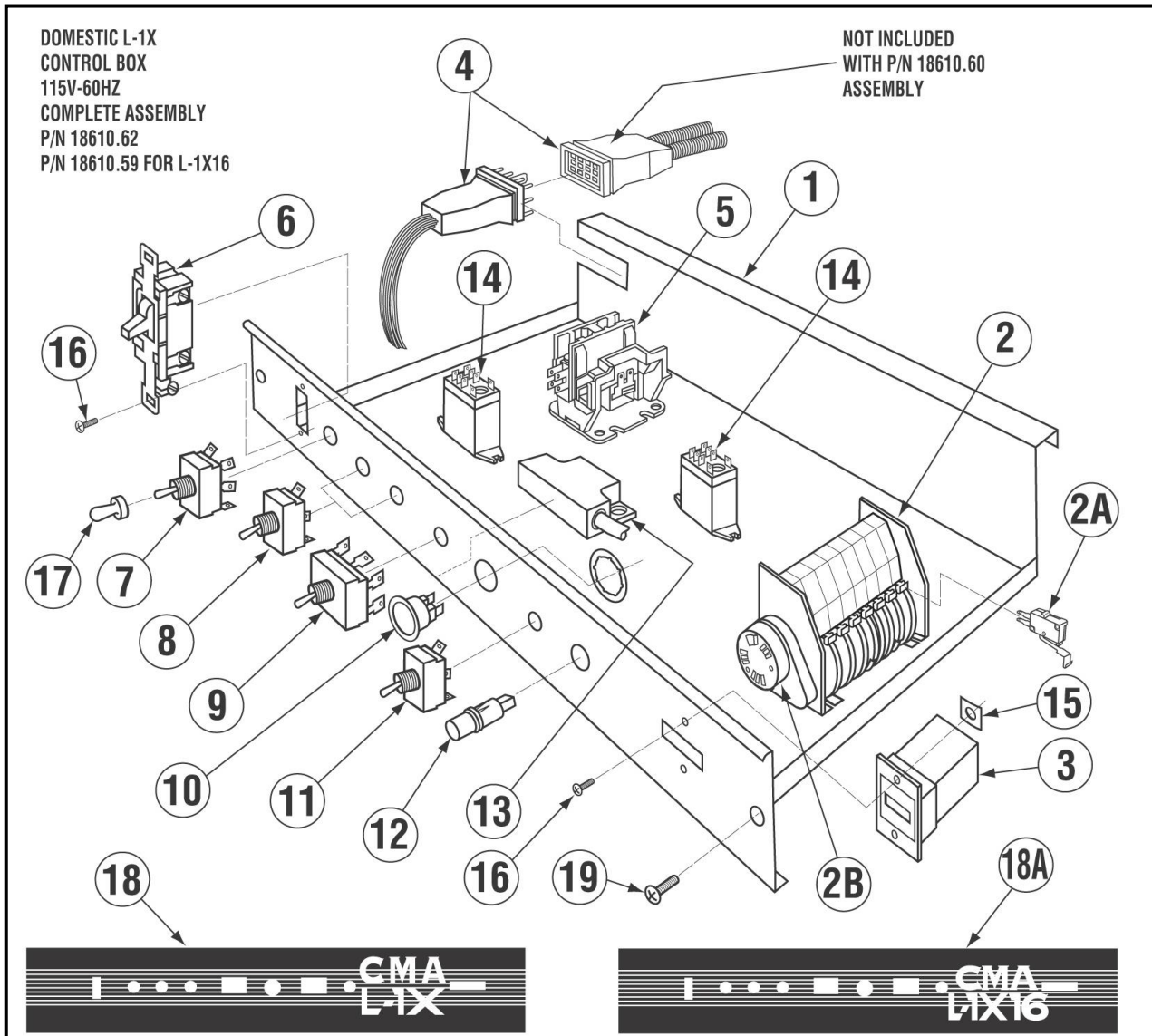

ITEM NO.	NO. REQ'D	P/N	DESCRIPTION
1	1	04904.60	Top Drawer
2	1	00408.80	Timer 2 Minute 8 Cam
2A	8	00411.00	Micro switch
2B	1	00501.00	Timer Motor
3	1	03408.50	Counter (Panel Mount – Small)
4	1	04415.00	Wire Harness (L-1X)
5	1	00404.82	Contactor Relay
6	1	00433.10	Master Switch
7	1	00475.30	Toggle Switch DPDT 16A, 2 pos
8	2	03470.00	Toggle Switch (Momentary)
9	1	03406.64	Drain Toggle Switch DPST

ITEM NO.	NO. REQ'D	P/N	DESCRIPTION
10	1	00476.00	Running Light 120V, Green
11	1	03470.01	Toggle Switch, mom., (.25 flat term.)
12	1	00406.00	Control box Light Red
13	1	00556.10	Reed Switch - ISI
14	1 or 2*	00631.00	Ice Cube Relay
15	2	00917.00	8-32 PM Nut
16	4	00911.00	8-32 x 1/2" Pan Head Screw
17	4	00470.10	Rubber Boot
18	1	06231.00	L-1X Drawer Label
18A	1	06231.02	L-1X16 Drawer Label
19	2	00940.50	10-32 x 3/8" Truss Head Screw

\*Second relay present only with heater option.

## 1.2.13. Control Box (Effective 06/2007)

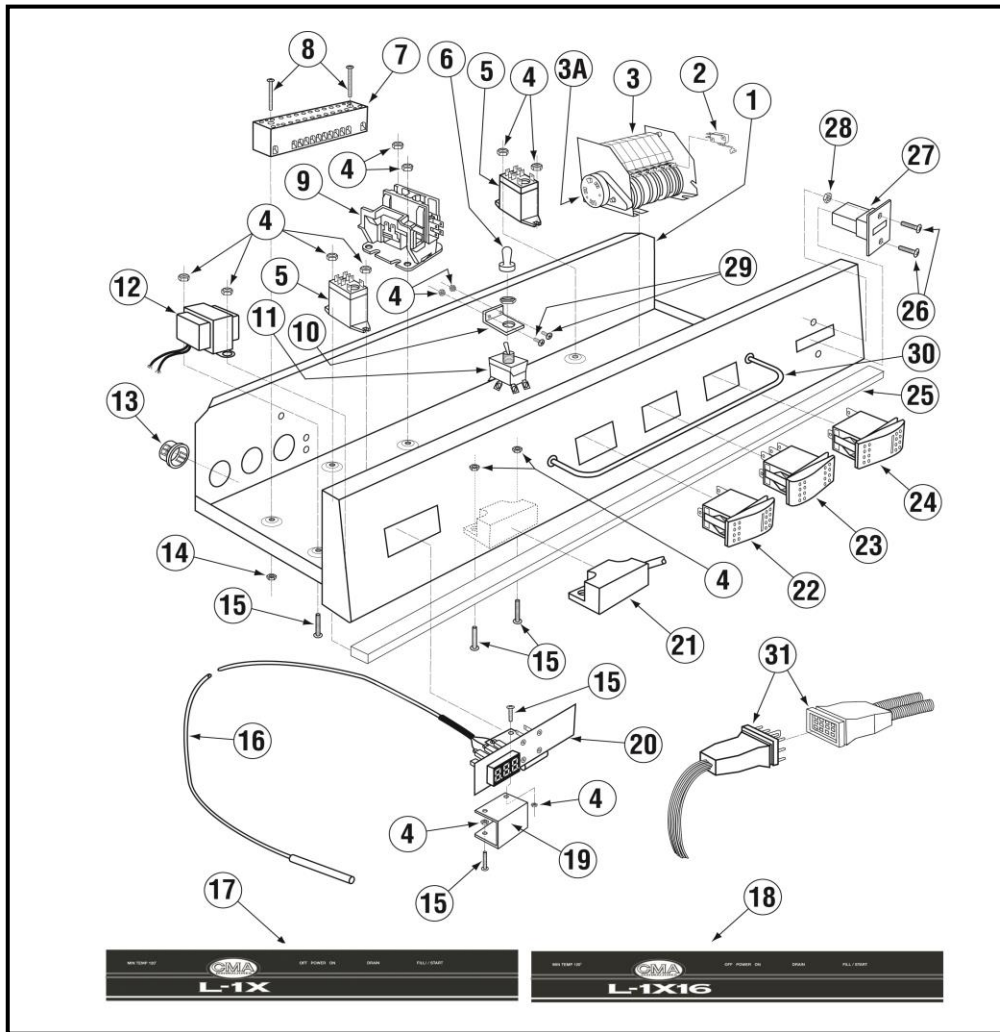

ITEM NO.	NO. REQ'D	P/N	DESCRIPTION
1	1	04904.60	L-1X Top Drawer (New 5-02)
		04904.78	L1X16 Top Drawer Slanted New
2	8	00411.00	Micro switch
3	1	00408.80	Timer 2 Minute 8 Cam
3A	1	00501.00	Timer Motor
4	18	00965.00	6-32 Nylon Insert Lock Nut
5	1 (2*)	00631.00	Ice Cube Relay
6	4	00470.10	Rubber Boot
7	1	15520.00	Power Block 12 Position
8	2	13826.10	4-40 X 3/4" Pan Head screw
9	1	00404.82	Contactur Relay
10	1	00474.00	Delimer Switch Bracket
11	1	00475.30	Delimer Switch DPST 20 Amp.
		00475.70	Delimer Sw. 20A 3Pos (New 5-19)
12	1	03202.60	Thermometer Transformer
13	1	00438.00	Snap bushing, Universal
14	2	13826.50	4-40 Hex Nuts

ITEM NO.	NO. REQ'D	P/N	DESCRIPTION
15	14	00907.00	6-32 X 1/2 SS Panhead Screw
16	1	03202.66	Thermocouple
17	1	06232.04	L-1X Drawer Label
18	1	06232.05	L-1X16 Drawer Label
19	1	03203.55	Thermometer Bracket
20	1	03203.51	Single Temp. Display Unit
21	1	00556.10	Reed Switch - ISI
22	1	15524.00	Power Rocker Switch (421.82 Cover)
23	1	03481.00	Drain Rocker Switch (3481.01 Cover)
24	1	00421.40	Start/Fill Rocker Switch (421.41 Cover)
25	2	03705.82	Sponge Strip
26	2	00907.10	6-32 X 1/2 Black Oxide Screw-Philp
27	1	03408.50	Counter (Panel Mount - Small)
28	2	00916.00	6-32 PM Nut
29	4	00421.51	6-32 X 1/4 SS Panhead Screw
30	1	03485.00	Switch Guard
31	1	04416.01	L-1X/L-1X16 Wire Harness Assy

## 1.2.14. Peristaltic Pump Assembly

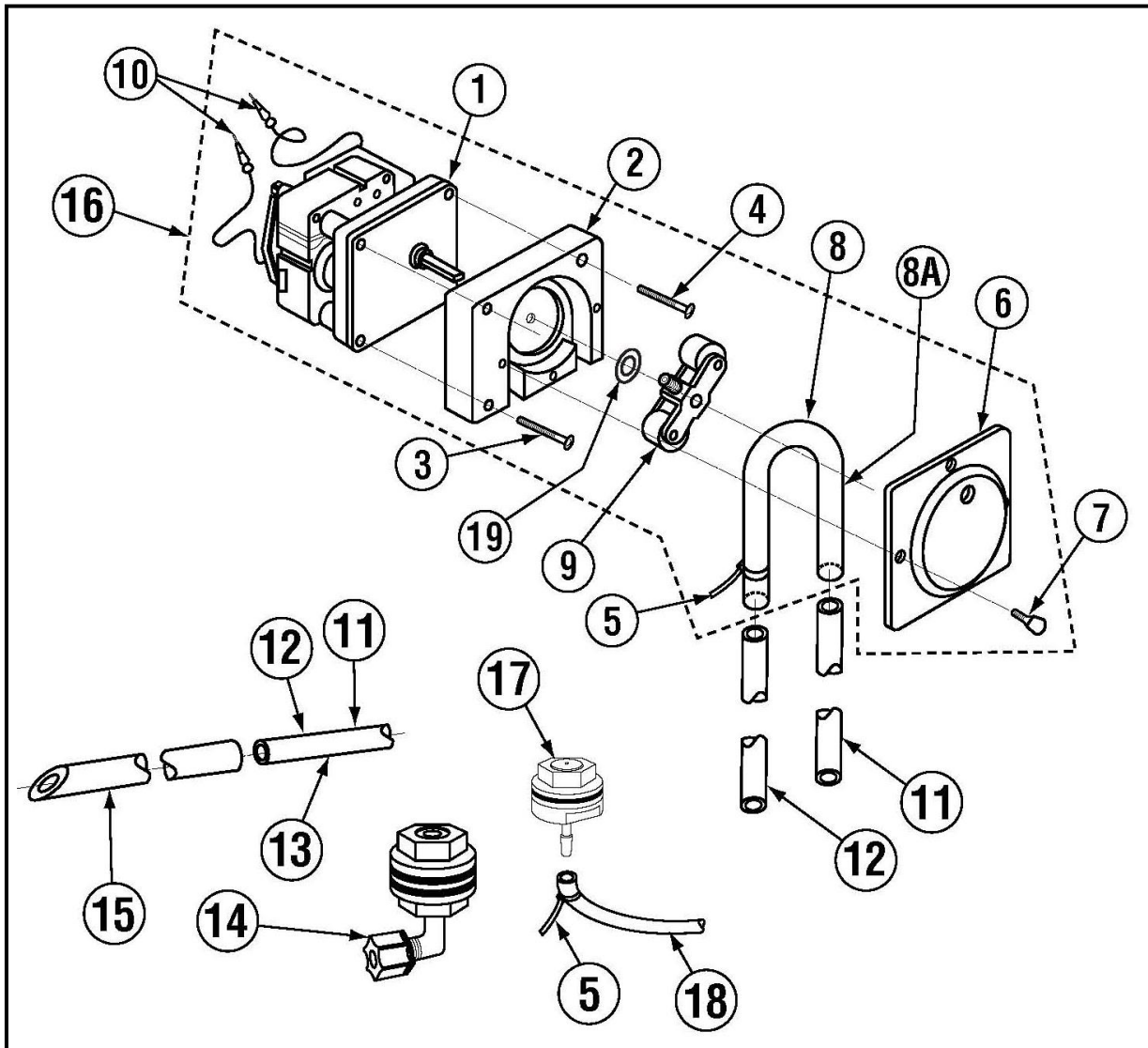

ITEM NO.	NO. REQ'D	P/N	DESCRIPTION
1	3	00416.00	Peristaltic Pump Motor
2	3	00417.10	Peristaltic Pump Block (Black)
3	6	00919.00	10-32 x 1 1/2" Pan Head Screw
4	3	00918.00	10-32 x 1 1/2" Fillister HD Screw
5	6	00932.00	Wire Tie – Large
6	7	00418.00	Peristaltic Pump Block Cover
7	12	00911.00	8-32 x 1/2" Pan Head Screw
8	3	02257.00	Squeeze Tube 8" Norprene
9	3	00419.00	Peristaltic Rotor Assembly

ITEM NO.	NO. REQ'D	P/N	DESCRIPTION
10	6	00448.00	Barrel Connector (Male)
11	AR	00425.51	Chemical Tubing (Blue)
12	AR	00425.53	Chemical Tubing (Red)
13	AR	00425.54	Chemical Tubing (White)
14	2	03415.00	Chemical Tube Bulkhead
15	2	00443.00	Tube Stiffener
16*	1	00415.00	Complete Peristaltic Pump
17	1	03415.60	Bulk Head For Sanitizer
18	1	02257.22	Squeeze Tube 22" Norprene For L-1X
19	1	00422.50	Rotor Spacer

\*Item 16 includes items 1-4, 6-10.

## 1.2.15. Drain Valve

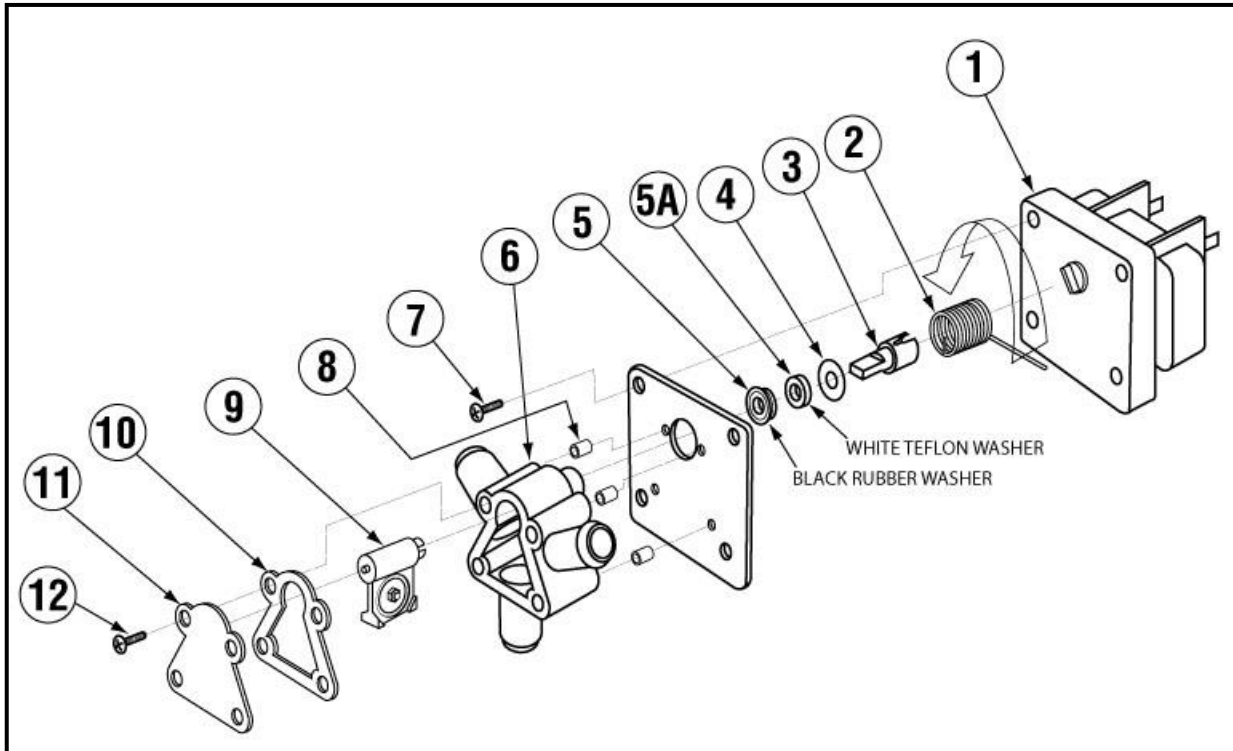

ITEM NO.	NO. REQ'D	P/N	DESCRIPTION
1	1	04103.21	Drain Motor 115V, 60Hz
2	1	<a href="#">04103.14</a>	Drain Valve Spring
3	1	<a href="#">04103.20</a>	Drain Valve Drive Pin
4	1	<a href="#">04103.19</a>	Drain Valve Washer (Thin)
5	1	<a href="#">04103.17</a>	Drain Seal Washer (Black)
5A	1	<a href="#">04103.23</a>	Drain Seal Washer (White)
6	1	<a href="#">04103.12</a>	Drain Valve Housing
7	4	<a href="#">00941.00</a>	#10-32 x 5/8" Pan Head Screw
8	3	<a href="#">04103.24</a>	Drain Valve Housing Spacer
9	1	<a href="#">04103.16</a>	Hinge/Seal
10	1	<a href="#">04103.15</a>	Drain Housing Gasket
11	1	<a href="#">04103.13</a>	Drain Valve Housing Cover
12	4	<a href="#">04103.18</a>	#8 x 5/8" Self-Threading Screw

## 1.2.16. Drain Valve (Effective January 2011)

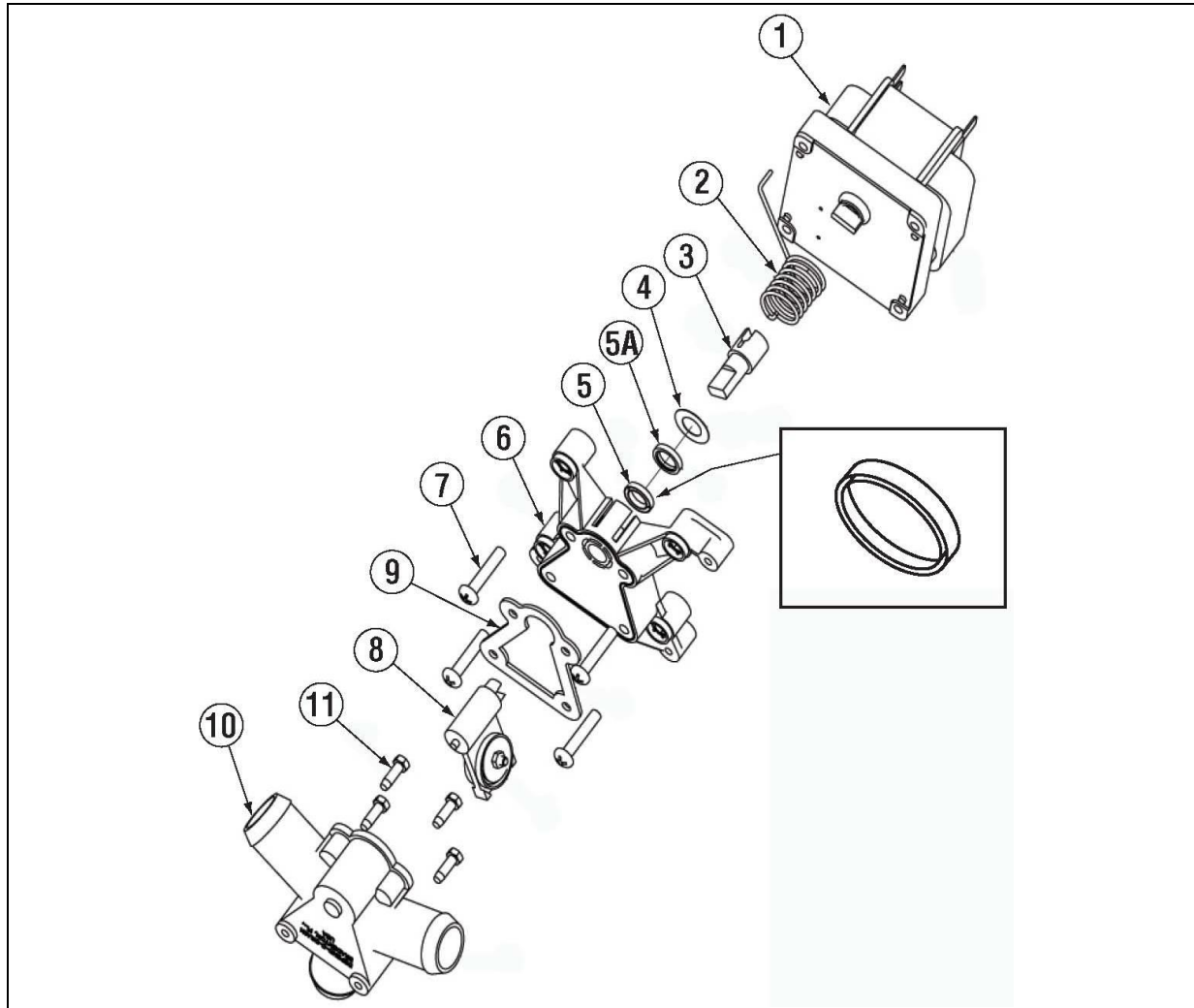

ITEM NO.	NO. REQ'D	P/N	DESCRIPTION
1	1	00104.50	Drain Motor 120V
2	1	04103.14	Drain Valve Spring
3	1	04103.20	Drain Valve Drive Pin
4	1	04103.19	Drain Valve Washer (Thin) SS
5	1	04103.17	Drain Valve Seal Washer (Rubber)
5A	1	04103.23	Drain Seal Bearing (White Washer)
6	1	04113.33	Drain Valve Housing Cover
7	4	04113.18	Valve Cover Screw
8	1	04113.16	Drain Valve Hinge/Seal
9	1	04103.15	Drain Valve Housing Gasket
10	1	04113.12	Drain Valve Housing ( Includes #11&12)
11	2	04113.21	Screw #6-32 X 0.625 Flanged Hex
12	2	04113.23	Screw - #6-32 X 1.5" Flanged Hex
13	1	04113.13	Valve Cover Assy. Rectangular

## 1.2.17. Optional Sani Alarm

Part Number **12508.00**

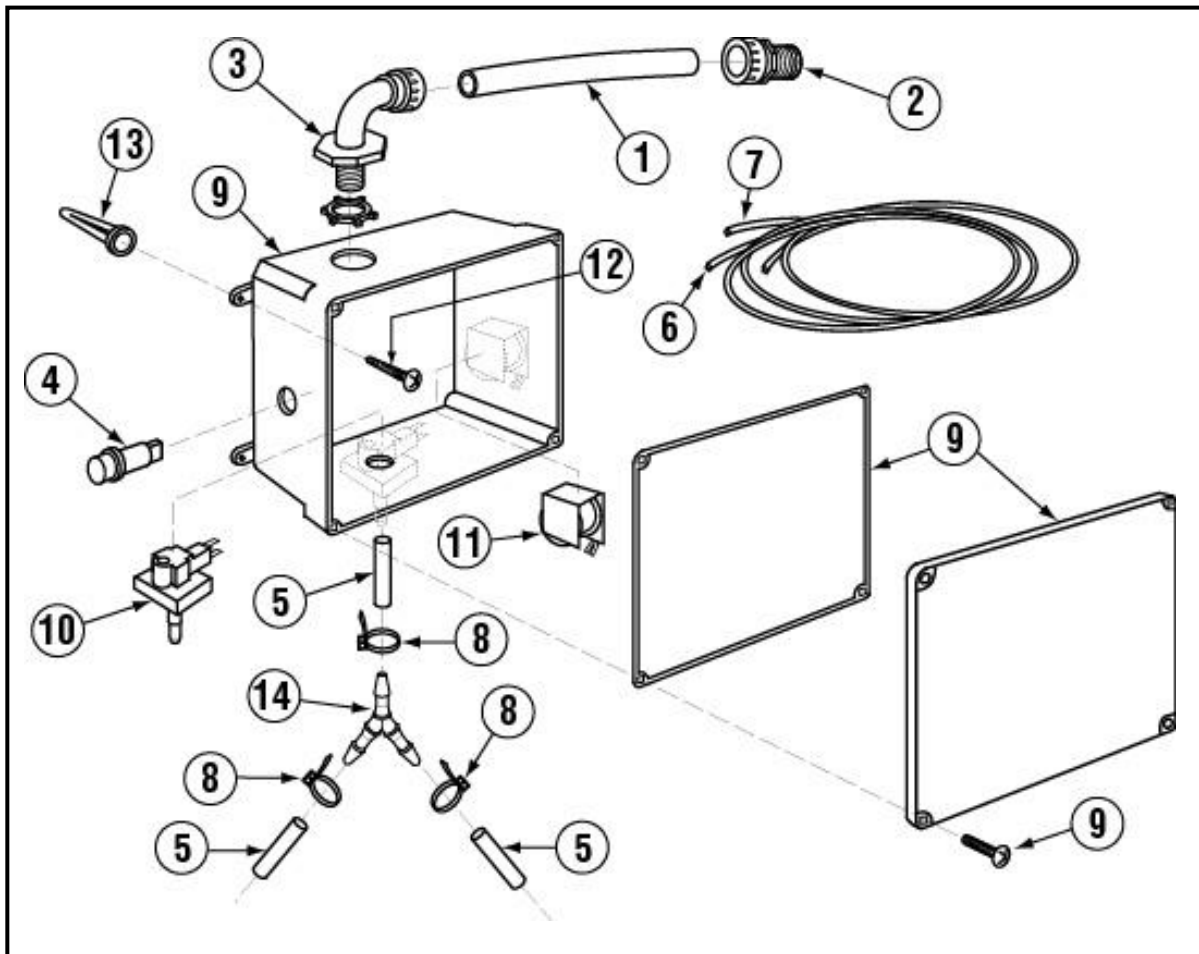

**Exploded View**

ITEM NO.	NO. REQ'D	P/N	DESCRIPTION
1	3	00400.00	Conduit, 3/8" Sealtite
2	1	00401.00	S.T. 3/8" Straight Connector
3	1	00402.00	S.T. 90 Degree 3/8" Connector
4	1	00406.00	Control Box Light, .5" Diameter, Red
5	1	00435.00	Squeeze Tube, 8"
6	1	00521.00	Wire, 18 Gauge, Orange, 6 ft.
7	1	00531.00	Wire, 18 Gauge, White, 6 ft.

ITEM NO.	NO. REQ'D	P/N	DESCRIPTION
8	5	00931.00	Wire Tie, Small
9	1	12510.00	Sanitizer Alarm Box Assembly
10	1	12511.00	Sanitizer Low Level Vacuum Switch
11	1	12512.00	Sanitizer Alarm Buzzer, 120 Volts
12	4	40126.10	#10 x 3/4" Sheet metal Screw
13	4	40127.00	Wall Anchors
14	1	00426.00	Y Hose Connector, 3/16"