

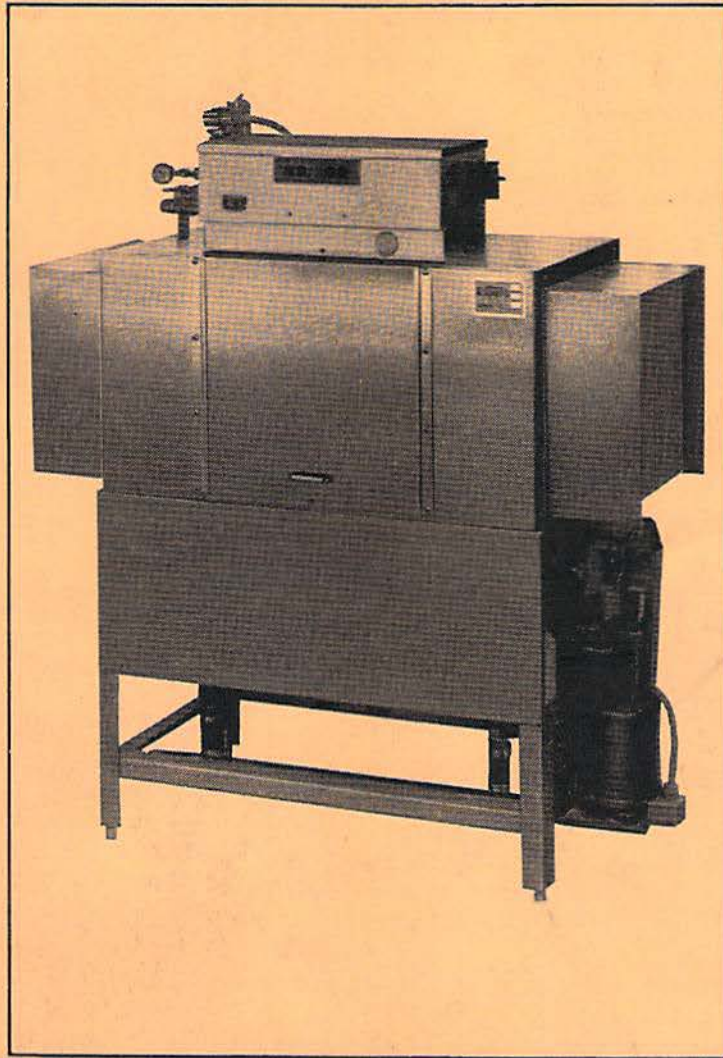

SERVICE & PARTS MANUAL



INTERNATIONAL MODEL M-2 DISHMACHINE SCJ-240 VOLTS - 3 PHASE 60 HZ

CHEMICAL METHODS ASSOCIATES
12700 KNOTT AVENUE
GARDEN GROVE, CALIFORNIA 92641

800-854-6417
FAX 714-895-2141



TABLE OF CONTENTS

	Page
Specifications	3
Preparation for Installation	4
Installation Notes	5-6
Electrical Power Requirements	7
Operation Instructions for M-2	8
To Begin Operation	9
Regular Service and Maintenance Check List	10-11
Pressure Regulator With Strainer	12
Technical Tips	13-14
Trouble Shooting	15-16
M-2 Instructions	17
Control Box Electrical Diagram	18
Dispensing System Operating Guide	19-20
Rack Saver System	21
Optional Table Limit Switch Assembly	22
M-2 Overload Contactor	23
Exploded View Section	24-37
Frame System Assembly	25
Conveyor System Assembly	26
Trip Switch	27
Plumbing System Assembly Low Temp	28
Plumbing System Assembly High Temp	29
Spray System Assembly	30
Final Rinse System	31
Drain System Assembly	32
Water Control System	33
Pump System Assembly	34
Control Box Assembly	35
Curtain and Vent System	36
Paddle Switch Assembly	37



SPECIFICATIONS

	M-2 L.T.	M-2 H.T.
WATER CONSUMPTION	.8 gallons per rack 193 gallons per hour	.94 gallons per rack 193 gallons per hour
OPERATING CYCLE		
Pre-wash time	15 seconds	17.5 seconds
Power wash time	15 seconds	17.5 seconds
Rinse time	15 seconds	17.5 seconds
Total cycle	45 seconds	52.5 seconds
CONVEYOR SPEED	6.75 ft./min.	5.7 ft./min.
OPERATING CAPACITY	242 racks per hour (NSF rated)	205 racks per hour (NSF rated)
HOLDING TANK CAPACITY	16 gallons	
PUMP CAPACITY		
Pre-wash/wash/rinse	38 gallons per minute each pump	
WATER REQUIREMENTS		
Inlet temp	Low Temp 140 degrees Fahrenheit/ High Temp 180 degrees Fahrenheit	
Water inlet IPS	3/4"	
Drain size IPS	2"	
Flow pressure	20 psi	
WASH PUMP MOTORS (2)	1 Horsepower @ 208/240, 3 Phase	
CONVEYOR MOTOR (1)	1/3 Horsepower @ 208/240, 3 Phase	
HEATER		
Heater (1)	10 Kw, 3 Phase	
DIMENSIONS		
Depth	25"	
Width	44"	
Height	54", 72" extended	
Standard table height	32-1/2" adjust to 34"	
Maximum clearance for dishes	19"	
Standard racks	19-3/4" x 19-3/4"	
SHIPPING WEIGHT		
Approximate Basic Model	750 pounds	
ELECTRICAL RATING		
Volts	208/240	
Phase	3	
Load Amps	31.6	
Requires clean 40 amp circuit		
Specifications subject to change without notice		





PREPARATION FOR INSTALLATION

When you receive your new M-2 Conveyor, complete the assembly by installing the curtain rods and two buffer sections which are shipped inside the machine. After the shipping crate has been removed from the machine, remove the left and right stainless steel buffer sections and bolt them in place with the nuts and bolts provided. **The buffer with the extra curtain clamps mounts onto the dirty end of the machine.**

All of the spray arms should be inserted and locked in place over the wash tank compartments. Make sure that the end caps are in place.

There are a total of five curtains used in the M-2; two are long and three short. Two of the long and one of the short curtains have shorter rods. The short rods hold these long curtains at the entrance and exit of the machine.

If the dish flow is from left to right, the proper sequence for the placement of the curtains would be long curtain, short rod, in the first station; short curtain, short rod, in the second station; short curtain, long rod, third station; short curtain, long rod, fourth station; short rod, long curtain, sixth station. The only curtain change to reverse the flow of dishes is that the short curtain #2 changed to #5. The sketch below lists the stations 1 through 6. In this case, it represents a flow to left to right. Reverse the sequence for right to left dishmachine.

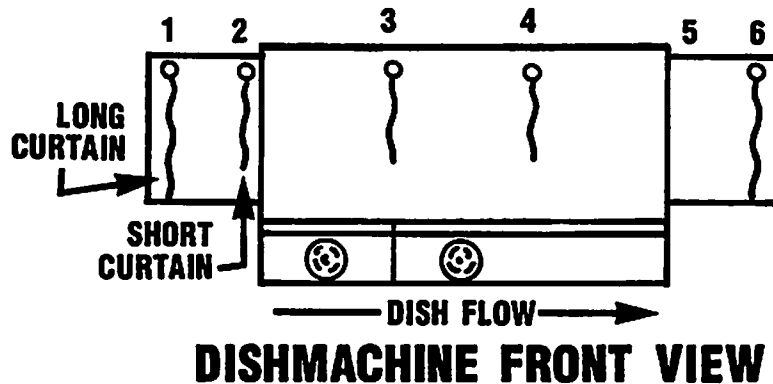

The M-2 is designed to give maximum cleaning in 44 inches. It represents the cleaning power of machines twice its length. The curtains incorporated in the machine minimize transfer from tank to tank during the wash and sanitizing procedures.

Energy costs for running the M-2 have been greatly reduced by the introduction of stage washing which incorporates activation of the wash tank and rinse tanks only when the rack is in place over each of the three compartments. This design allows the heavy food soil to be removed in the first station which provides a relatively clean dish before it reaches the wash stage in the center tank.



INSTALLATION NOTES

1. Tables must slant into machine (for 28" of Table we recommend a drop of at least 3/4" in table height).
2. Tray rail is not to be moved up or down. Any change will alter the position of the Tilt Switch in relation to the dish rack or the dish rack in relation to the conveyor dogs.
3. Use wide angle 90 degree plumbing for scrap trap (to avoid debris from blocking the scrap trap drain). This could result in flooding the machine.

The scrap accumulator is plumbed to the two inch exit on the entrance side (or dirty dish side) of the machine. The machine is designed to deliver .8 L.T./94 H.T. gallons of fresh rinse water which carries from the rinse and power wash tanks, into the pre-wash tank and then exits out into the scrap accumulator. SEE DIAGRAM.

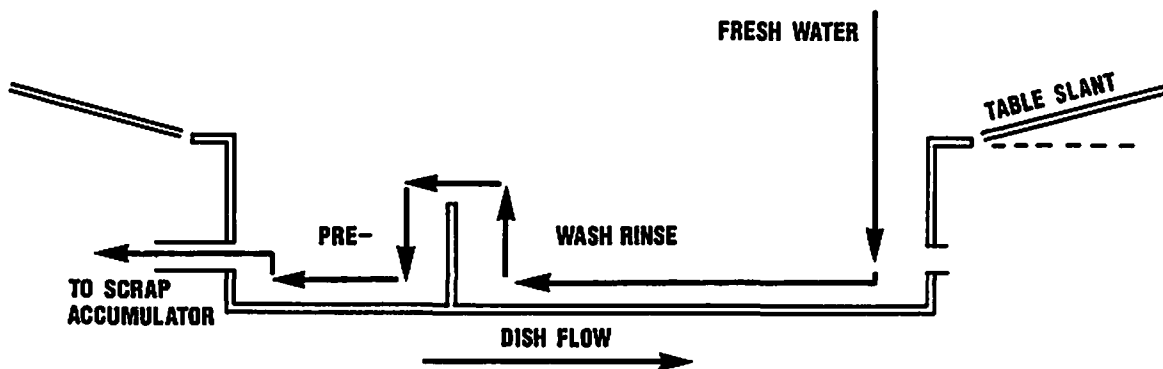

4. Observed rotation of the Conveyor Cam.
 - If rotation is clockwise as you are looking at the machine from the front, that is correct.
 - If it is counter clockwise, the movement of the rocker arm will unscrew the cam bearing.
 - To change rotation switch any two wires at motor.
 - See (below right) for conveyor speed cam locations.
5. Water pump motors must be checked for proper rotation:
**Caution – motors are 3 Ph. Check rotation. Motors must turn clockwise looking at shaft from back of motor. Remove dust cap on back of motor to check rotation of motor shaft.*
6. Incoming wire for the M-2 should be at least an 8 gauge wire for L1, L2 and L3. Connect highest voltage wire (stinger) to L-2.
7. If tables enter conveyor machine at a 90 degree angle and buffer or splash shield cannot be used, modify shield by cutting on a diagonal. It will provide some protection from splash.

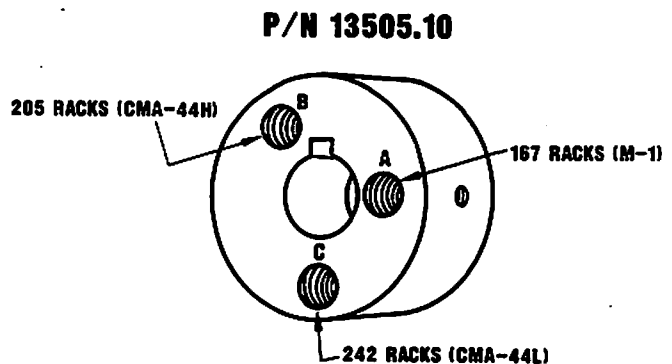
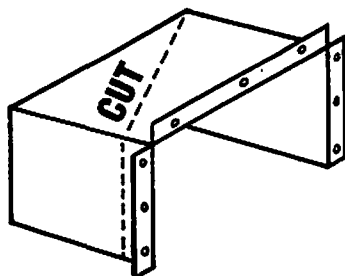



INSTALLATION NOTES

8. Make sure that all racks used will press lever switch down – far enough to activate. If they DO NOT, adjust tray track so that the racks will.
9. No Quick Drains should be installed on tables before or after machine. They must be plumbed back into machines or welded over and capped off.
10. The diagram below should be viewed as though looking at from the inside of the machine. The diagram indicates proper tilt switch adjustment. Adjust cam to activate micro switch, when trip switch is level with tray track.

NOTE: If not adjusted properly:

1. Final Rinse will turn off and on several times when dish rack releases tilt switch and it rocks back and forth.
2. Final Rinse may turn off prematurely leaving rack of dishes improperly rinsed.

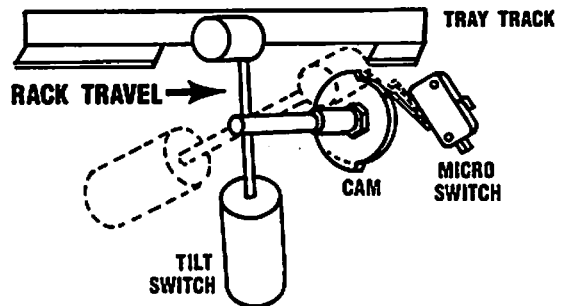

11. The water inlet is attached to the inlet line of the top of the machine with a three-quarter inch, 140 L.T., 180 H.T. degree hot water supply.

NOTE: Make sure that the primary heater is set to deliver 140-150 degrees to the machine. If unsure, turn down the booster heater to 140-150 degrees and leave it on line. Be sure the water source is 3/4" inlet all the way from water heater or water softener. No 1/2" restrictions. **The High Temp machine comes with two incoming water line connections.** One is for the final rinse at 180°F and the other is to fill the machine 140°F. *High Temp must be 180°F water supply to final rinse valve and an additional 140°F supply line to machine fill valve.

12. **VERY IMPORTANT** – Set Pressure Regulator while machine is in FINAL RINSE CYCLE; correct pressure is 20 psi (+ or - 2 lbs.). Turn adjustment screw clockwise to increase final rinse pressure.
13. The diagram below shows the proper spray arm alignment to prevent tank to tank contamination and excessive spray reflecting out of machine. *See #7 under Regular Service & Maintenance Check List.

CORRECT SPRAY ARM ALIGNMENT

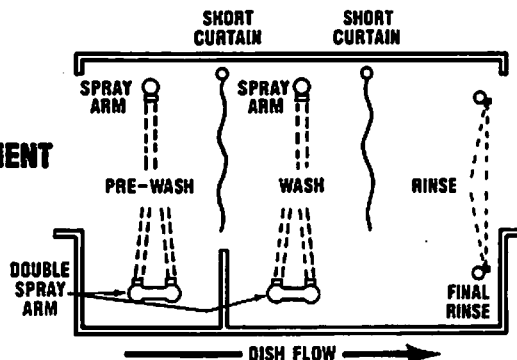

14. Mixing Chamber

CAUTION: Supplied check valves should be installed parallel to the machine where chemicals will not leak onto stainless. Have sanitizer line enter chamber without any bends to prevent leaks at check valve.

FIELD-INSTALLED ACCESSORIES

Installation of the accessory chemical pumps must be conducted by qualified personnel.

CHEMICAL DISPENSERS

Connect only to primary of listed Class 2 Transformer 208-240 V., 60 Hz maximum 100 VA.

M-2 requires 208/240 volt, 3 phase power. Connect the wire that indicates the highest voltage (stinger lead) to L-2 powerblock connection.

Install M-2 Conveyor on a clean 40 amp breaker.

**IMPORTANT: Check that motors are turning in the correct direction. Looking at shaft of motor on the back side, it should be turning clockwise. If one or both pump motors are turning in the wrong direction switch L-1, L-2 & L-3 wires until correct direction is found.*

M-2 HEATER

The 10 Kw, 3 phase heater is located in the wash/final rinse tank. The heater has an independent power switch which is activated when ready for operation. If one was to drain the tank and leave the heater on, the thermostat would receive a signal to shut down from the float switch, located along side heater in the rinse end of the tank.

**We do recommend that the heater is shut off when machine is not in operation.*

Thermostat is located behind stainless cover on final rinse side of machine. There is a thermostat adjustment access hole located on this cover.

SAFETY TIPS FOR M-2

- | | |
|----------------|--|
| DANGER | Always turn off circuit breaker at wall when working on dishmachine. (Remember it is 220 voltage.) Even with machine switched off there is a live connection coming to the switch so switch off circuit breaker. |
| CAUTION | Do not get in path of conveyor rocker arm and the conveyor moving bar. Do not reach into rocker arm area without first making sure the dishmachine is turned off at the circuit breaker. |
| CAUTION | Do not open front door when machine is in operation. |
| CAUTION | Avoid water spraying on electrical control box on top of the dishmachine. When cleaning, do not spray water directly on to motors. |
| CAUTION | When cleaning final rinse arms that are plugged, exercise caution when removing. The final rinse arms are under pressure and filled with chemicals. |



OPERATION INSTRUCTIONS FOR M-2

- A. Make sure the drains are closed (handle turned horizontal).

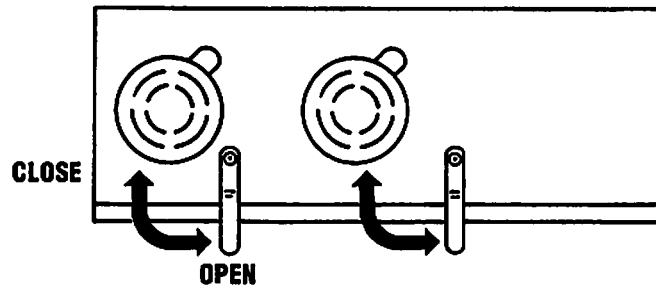

- B. Turn on circuit breaker from power source. Turn ball valve on and fill machine until overflowing out pre-wash tank.
- C. Turn heater switch on and make sure water temperature is between 140-150 degrees. Tank heater will hold temperature at 140° if final rinse is providing 140°-150° at all times (Low Temp) and 150°-160° for High Temp if final rinse is maintained at 180°.
- D. **IMPORTANT**

Placement of dishes in rack:

Make sure dishes are placed correctly. If they become dislodged, they could interfere with lever tilt switch and interrupt the operation of the machine.

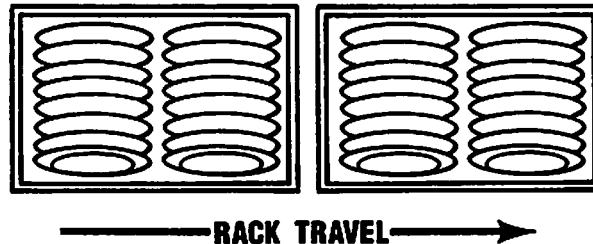

- E. At the end of the day and after heavy periods of accumulation, clean strainer trays. There are 5 trays inside the machine. Also, remove six spray arms and clean. After cleaning spray arms, take caution in returning to holding sockets in tanks.

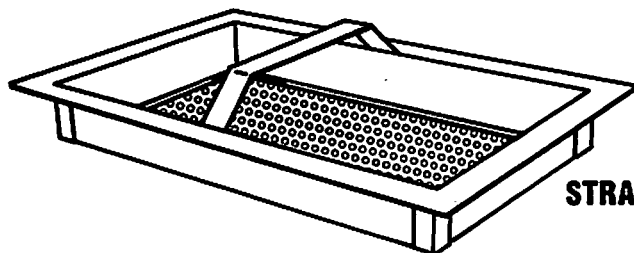

STRAINER TRAY

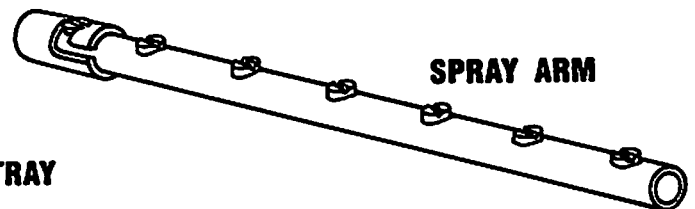

SPRAY ARM

*** When water becomes heavily soiled, drain tanks and refill machine.**

- F. Check chemical buckets. Make sure there is adequate supply of detergent, rinse aid, and sanitizer (L.T.). Also check that pick-up line is inserted into correct bucket.
- G. Activate trip switch on pre-wash end of machine. The 60 sec. time delay-off relay will lock the machine in the run position for 60 sec. then shut-off. This delay-off relay can be adjusted from 0-60 sec. This relay prevents machine from running when flight of dish racks are not in machine.



TO BEGIN OPERATION

1. Turn Power on to machine (circuit breaker from power source).
2. Turn manual ball valve to fill machine until water flows out overflow on pre-wash end of machine.



**OPEN FILL VALVE UNTIL
BOTH TANKS OVERFLOW.
CLOSE FILL VALVE.**

3. Turn on Heater Switch and wait until temperature rises to 140°-150° Low Temp and 150°-160° for High Temp.



TURN ON HEATER

The rinse and sanitizing agents are not injected during the initial fill stage. They are injected into the final rinse make-up water when the tilt switch is activated in the final rinse tank.

Inside the control box is a labeled power block for sanitizer and rinse aid which is powered when the final rinse tilt switch is activated. The detergent power block is labeled and provides power when the conveyor and pump motors are operational.



REGULAR SERVICE & MAINTENANCE CHECK LIST

1. Upon entering the facility, make a preliminary check of the flatware and glasses, especially stemware. This will give you a quick indication of how the machine is functioning.
2. Go to the M-2, turn off the circuit breaker providing power to the machine. Open the door and check the interior condition of the machine.
 - a. The stainless on the inside of the machine should be clean and shiny, no dull look or buildup of white lime scale.
 - b. Check the condition of the scrap trays for excessive garbage. Make sure the machine operator is cleaning the machine, explain proper cleaning procedures.
 - c. Open the drains and check to make sure they are all working properly.
3. Once the machine has drained, remove both end curtains from the scrap and rinse and remove all the scrap trays from the machine. A. Check all spray arms and jets – clean and explain cleaning procedures to dishmen. B. Check the drain openings making sure they are free and clear of debris. C. Check the heater element. It should be black with no splits, breaks, or cracks.
4. Close the drains, turn the power on and fill the machine.
 - a. Check fill vacuum breaker for leaks.
 - b. This is a time to check the water hardness. Check the water at the fill while it is coming into the machine.
 - c. Using a curtain bar or something long, turn on the final rinse and observe the spray pattern of the final rinse jets. It is easier to see while the pressure is lower. If you have any clogged rinse jets, clean them using a bent paper clip.
5. Check the heater to see if it is working. If the temperature is below 140 degrees, check the fuses near the heater contactor, and check the thermostat setting. Also check that the heater contactor has activated. The contactor plunger should be in the PULLED-IN position. Check that the float switch is working properly.
6. With the machine full, replace all of the scrap trays into the proper position.
7. Place a rack into the machine, and observe the spray pattern of the pre-wash and the final rinse station.

***The M-2 has an excellent feature about it which is helpful in checking the spray pattern. The wash pump motors and the conveyor motor can be operated independently from one another by pushing the test switch located on the top of the mag starters. Disarm one mag starter at a time and observe the spray arm spray pattern for needed adjustments.**

By disarming the conveyor motor while a dishrack is in the final rinse section this makes it convenient in setting the chemical levels.

 - a. Check the titration of the wash tank at this point.
 - b. While the rack is in the final rinse, check the chlorine for 50 ppm in the final rinse.
 - c. Observe final rinse vacuum breaker for leaks.
8. Run a stemware or glass rack through the machine at this point and check the results on the glassware.
 - A. Observe the check valves for the rinse and sanitizer. Make sure they are not leaking or building up chlorine crystals. If they are clean, leave them alone. B. Check the condition of the chemical tubing from the peri pump to the check valves. C. Check the peri pump squeeze tubes to make sure they are tight, pumping product properly and not leaking within the peri pump. There should be no moisture within the peri pump itself. D. Observe the final rinse pressure at 20 psi \pm 2. Adjust if necessary.



SPECIAL TOOLS NEEDED IN SERVICING THE M-2 CONVEYOR:

Electrical Test Equipment

1. Voltage/ohms tester
2. Amp probe

Hand Tools

1. Small snap ring pliers
2. Mechanical fingers (flexible or rigid)
3. Thermometer
4. Allen wrench set
5. variety of hand tools

TEST TO RUN

Heater Circuit 10 Kw 3 Phase heater should read 21 amps on any of the three wire connections. Check that all three 30 amp fuses are good.

Tilt Switch If a tilt switch becomes loose and inoperative, it will be necessary to remove it by taking the snap ring from the shaft after the cam has been taken off. Then the tilt switch can be pulled from the inside after which the bearing and brass sleeve can be tightened or replace.

Elect All controls in the M-2 conveyor are operated with 208/240 voltage. The power supply to the three motors and heater element is 208/240 voltage three phase.

Thermostat If it become necessary to adjust the thermostat, it can be done by removing hole plug on heater cover and turning set screw clockwise to increase. Heater cover is on the final rinse side of machine tank.

Best results are obtained if line water temperature at machine is 150 degrees F for Low Temp and 180°F for High Temp.

If all tests have been made and all components are satisfactory, a solution (if an answer still has not been found), may be a loose connection or poorly crimped wire. This will keep full power from reaching the motor or heater.

When testing for voltage in the M-2 conveyor, start at the power block and follow down to the end (defective item). When you lose a voltage reading, you have found your problem.

Final Rinse Arms Recommend keeping extra rinse arms on service trucks, in case of hard water clogging, soak clogged arms in a delimer back at shop.

SERVICE CHECK LIST

1. Inspect Chemical Dispensing Units
 - A. Peri-pumps
 - B. Squeeze tubes
 - C. Chemical line (tubing)
 - D. Check valvesMake sure that the product is being dispensed.
2. Inspect Tilt Switch
 - A. Is tight (no leaks)
 - B. Does arm move freely?
 - C. Is micro switch properly positioned?



TECHNICAL TIPS

3. Check overflow drain. Is it clear of debris?
4. Check primary drain.
5. Inspect heater.
6. Remove any debris from tanks.
7. Inspect conveyor dogs. Do they move freely?
8. Inspect curtain for proper placement and wear.
9. Fill machine and check for leaks.
10. Check that proper water level is maintained during operation. Adjust arms if water level drops in either tank.
11. Check incoming water temp. Should be 140-150° Low Temp and 180° final rinse and 150-160° wash tank High Temp.
12. Test pH in wash tank.
13. Run a flight of racks. Make sure heater is on. Check results and ppm available chlorines.
14. Grease Cam Bearing.

The attached list is recommended for the initial inventory of parts which are unique to the CMA-44 and not in standard distributor inventory.

13997.82
SCJ M-2 INITIAL PARTS INVENTORY
240V 60HZ

P/N	DESCRIPTION	NO. REQ'D
00200.85	MOTOR ASSY - 1HP 3PH 220V 60HZ	1.0
00411.00	MICRO SWITCH (TIMER)	3.0
00421.85	M-2 HTR ROCKER SWITCH AMBER	1.0
00471.10	ON/OFF SWITCH	1.0
00558.00	MAGNETIC REED SWITCH	1.0
03202.00	THERMOMETER (M-2, L1-C, VA)	1.0
13003.40	M-2 HEATER CONTACTOR	1.0
13003.70	TIMER RELAY OVERRIDE SWITCH	1.0
13012.10	M-2 MOTOR STARTER (SQD)	1.0
13012.20	1HP OVERLOAD RELAY (SQD) 50/60	1.0
13012.30	1/3HP OVERLOAD RELAY (SQD) 50/60	1.0
13304.30	SS FNL RINSE SPRAY ARM LT COMP	1.0
13304.82	SS FNL RINSE SPRAY ARM HT COMP	1.0
13305.00	SPRAY ARM END CAP - SS	1.0
13403.30	FUSE 7 AMP - SLOW BLOW GLASS	3.0
13403.83	FUSE 30 AMP LOW PEAK M-2	3.0
13408.85	M-2 TRIP SWITCH	1.0
13411.00	LOCK RINGS/TILT SWITCH - SMALL	2.0
13417.77	IMMERSION HEATER 3PH 240V 10KW	1.0
13417.85	THERMOSTAT 10KW HEATER M-2	1.0
13418.85	60 SEC TIMER RELAY	1.0
13419.85	TIMER POWER BLOCK SOCKET	1.0
13463.00	LIQUID LEVEL SWITCH M-2	1.0
13501.85	MOTOR 1/3HP 208/220 60HZ 3PH	1.0
13504.00	GEAR REDUCER	1.0
13507.50	CAM BEARING S/S	1.0
13508.30	RACK SAVER CLUTCH SPRING	1.0
13508.32	RACK SAVER CLUTCH SPRING EXTRA STRONG	1.0
13515.00	CONVEYOR DOG SS	1.0
13521.50	CONVEYOR BAR SLIDE BRNG M-2	1.0
13656.00	M-2 MIXING CHAMBER (NEW)	1.0
13658.00	CHEMICAL INLET CHECK VALVE	2.0



TROUBLE SHOOTING

PROBLEM	CAUSE	SOLUTION
Pre-wash/power wash motor inoperative	Bad motor or capacitor	Replace defective motor
	Mag Starter Overload tripped	Replace defective motor
	Faulty Mag Starter or Overload Relay	Replace
Heater No heat	Fuse burned	Replace fuse (check again after installed)
	Defective element	Replace element
	Thermostat not adjusted	Adjust, turn clockwise for higher temp
	Burned or loose wire	Follow back on wires and replace
Low heat during operation	Low incoming water temp (should be at least 150°F, 180°F for High Temp)	Turn up supply or booster heat. Insulate pipe. Check for cold water mixing
	Incoming water being deflected out of machine. Check all three heater fuses (30 Amp).	Correct placement of ware on rack. Correct curtain placement. Correct table slant into machine. Check alignment of spray arms.
	Water washing out of machine	Slant tables into dishmachine
Low spray arm pressure (approx. 8 psi)	Limed up rinse spray tips	De-line machine – clean out rinse spray tips with a piece of wire
	Low water, clogged	Check above causes. Check inlet hole for debris (tooth picks, straws)
	Water washing out of machine	Slant tables into dishmachine
Low water level	Limed up final rinse tips	De-lime machine – clean out rinse with a piece of wire.
	Spray arms not aligned properly	De-lime final rinse system. Connect rinse pump pick up line to de-limer container, activate final rinse tilt switch. Chemical will be drawn up to mixing chamber and flush system.
CAUTION: MUST DRAIN TANKS AND DISCONNECT SANITIZER CHEMICAL PUMP WHEN DELIMING		
High water level	Not draining out of machine	Clear opening to trap
Machine will not operate (power supply is coming into control box)	Defective on/off switch or contactor	Replace



TROUBLE SHOOTING

Water pump motor runs continuously	Limit switch activated or defective	Remove rack activating switch, replace switch
Racks stay in machine and will not exit	60 sec. timer faulty or needing to be set properly	Set properly or replace
	Broken, bent racks. Rack rail alignment.	Replace, adjust 1/8" above tank top lip or table height
	Rack rides on conveyor dogs. Dogs too high or low.	Free dog movement, alignment. Dogs need to be 1/2" higher than table.
Low or no pressure in final rinse spray	Defective solenoid valve	Replace water solenoid kit
	Final rinse pressure below 20 psi.	Adjust regulator. Increase pipe size to machine.
	Plugged jets	Remove and clean
Rinse water runs	Rinse/tilt switch stuck "on". Tilt switch cam adjusted properly.	Remove, clean, make free moving. Adjust.
	Defective water solenoid kit.	Replace
Chemicals not injecting:	Check chemical power block	Check for power
	Supply has emptied	Replace with new supply
	Chemical line cut, burned or leaking	Restore
	Dispenser malfunction	Check for power at dispenser and at pump



M-2 INSTRUCTIONS CUSTOMER NOTICE TEN TIPS TO SAVE THE \$25.00 SERVICE CHARGE

If a service call is initiated by the Lessee of this equipment and it is subsequently determined that the problem does not relate to part failure or out of chemicals, there will be a minimum \$25.00 service charge for serviceman to respond.

1. Circuit breaker found in "off" position.
2. Clogged drains (at any point in drain line – it is not a garbage disposal).
3. Lack of soft water (check salt level in brine tank).
4. Lack of hot water due to valves shut off or incorrect thermostat settings.
5. Failure of equipment unrelated to machine.
6. Abuse to equipment or failure to perform minimum cleaning requirements as outlined at time of installation.
 - A. Rinse arm tips clean and free of debris.
 - B. Strainer trays clean and free of debris.
 - C. Water tank drain and pick up openings clean and free of debris.
7. No water pressure in spray arms due to end caps missing caused by operator neglect.
8. Lever switch blocked or held from free movement due to lodged utensil or dish.
9. Lines to chemical buckets found in wrong containers or empty. (Note: Lines to buckets are color coded.)
10. Lessor's service responsibility shall be limited to its initial orientation, delivery of chemicals, adjustment of chemical injection system, and replacement of parts found to be worn or defective.

**M-2 CONVEYOR W/NOVA CONTROL
240V**

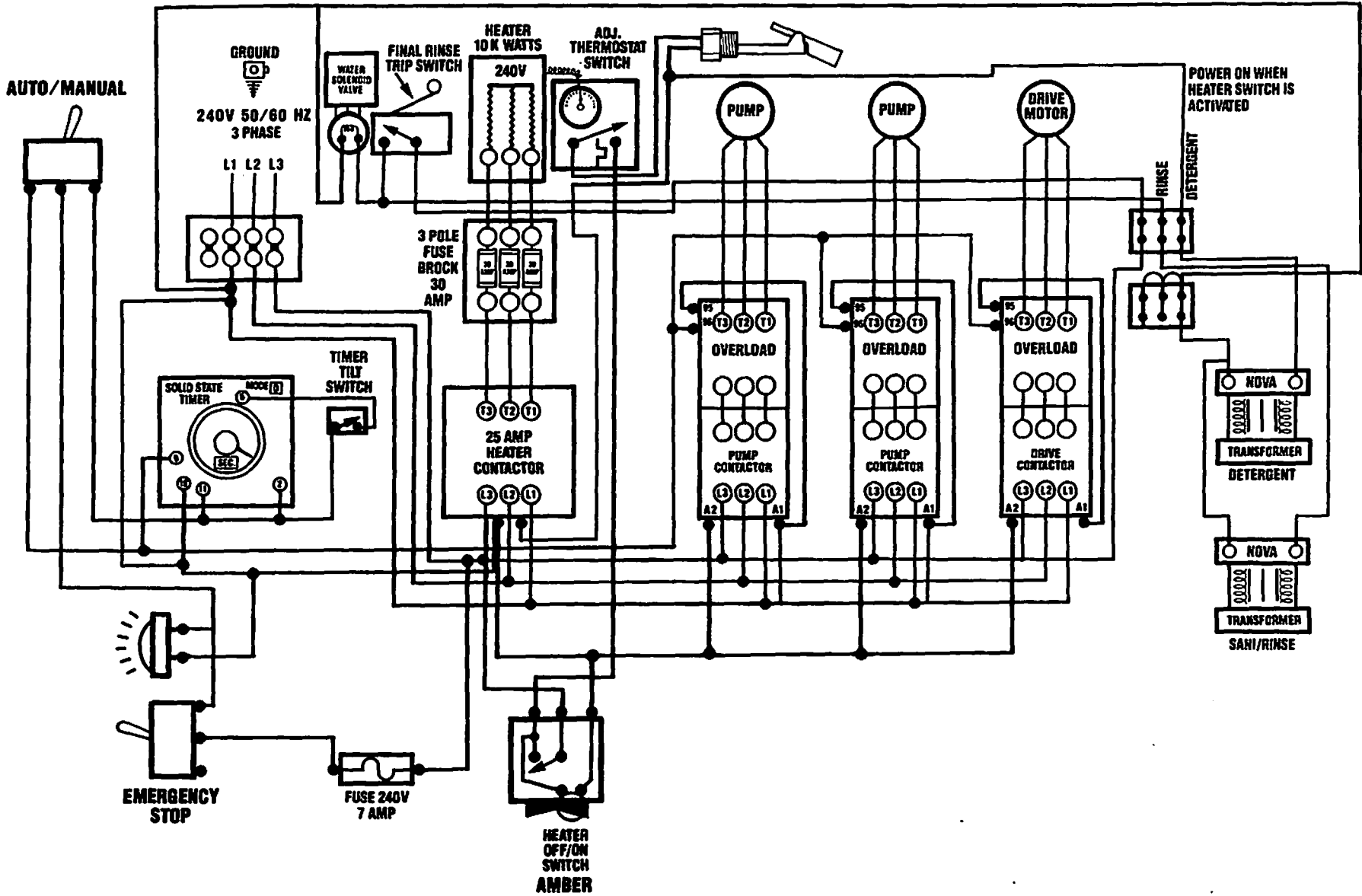

M2-CONVEYOR WASHER CHEMICAL DISPENSING SYSTEM.

This washer is equipped with the SYNCHRO automatic cleaning product dispenser, model DM-220.

SUGGESTED SETTINGS

A. Set "INITIAL CHARGE" dial to the "2" position.



B. Set "DOSE AMOUNT" dial to the "1" position.



C. Set "RINSE" setting to the "2" position.



Check actual wash detergent strength and adjust as necessary.
Check rinse results and adjust as necessary.
See below for ADJUSTMENTS procedure.

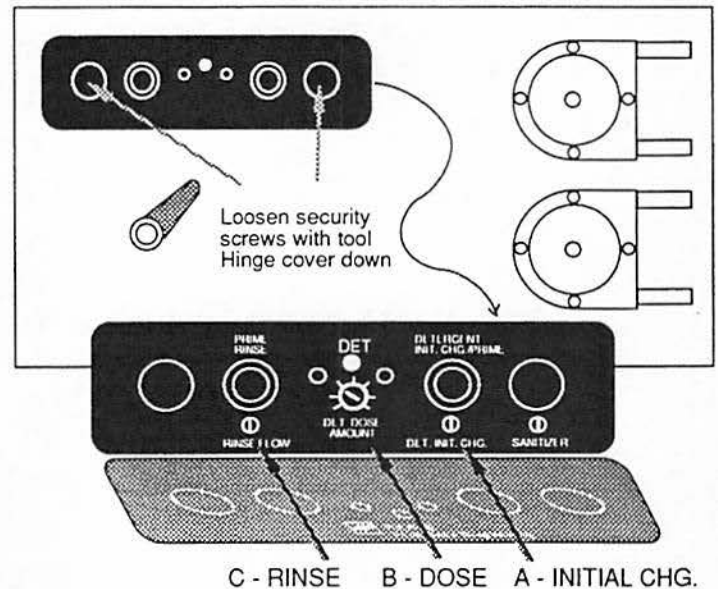

ADJUSTMENTS

SET DETERGENT DOSE AMOUNT and INITIAL CHARGE.

1. Turn **DETERGENT DOSE AMOUNT** to maximum (fully CW**).
2. Turn **DETERGENT INITIAL CHARGE** to midpoint.
3. Power unit (place washer in continuous rinse during setup). The rinse pump will run and the detergent pump will run. The Initial Charge Detergent light will be lit.
4. While the detergent pump runs, slowly adjust **DETERGENT INITIAL CHARGE** potentiometer CCW so pump just stops at the correct measured amount or at the estimated time (1 sec.=0.1oz or 3ml.). The exclusive **QuickSet** feature lets you make this setting in one step.
5. If the automatic Initial Charge activation has already occurred then press the **INITIAL CHARGE/PRIME** button until the pump starts, then release and follow step 4 above.
6. After 75 secs the detergent pump will run for the recharge dose amount. The Dose/Recharge detergent light will be on.
7. While the detergent pump runs, slowly adjust **DETERGENT DOSE AMOUNT** potentiometer CCW so pump just stops at the correct measured amount or at the estimated time (1 sec.=0.1oz or 3ml.).

SET RINSE FLOW.

1. Adjust CW, minimum=0, midpoint=6mls, max=12mls, per 12 seconds of rinse.

**NOTE ABBREVIATIONS: CW=clockwise, CCW=counter-clockwise.

WIRING

1. The washer rinse solenoid power has been prewired to the dispenser "Rinse" transformer at the appropriate voltage setting 240, 208, 110VAC. (Output to PCB is 24VAC.)
2. The heater power has been prewired to the "Initial Chg." transformer at the appropriate voltage setting 240, 208, or 110VAC.

JUMPER SETTINGS

The PC board jumper settings should be as shown:

Washer type	DOOR	CONVEYOR
Product type	SANITIZER	DESTAINER
Activation delay	RINSE DELAY (6 secs)	NO DELAY
Accumulated rinse time per dose	25 SECS	75 SECS
Initial charge	INIT CHG. AUTO	INIT. CHG. MANUAL

DESCRIPTION OF OPERATION

1. When the heater switch is switched ON the Detergent pump will automatically run for the Initial Charge amount that you have preset. The INITIAL CHARGE detergent light will be on.
2. Whenever the rinse is on the rinse pump runs at the speed you have preset. The RINSE light will be on.
3. After each 75 seconds of rinse operation the Detergent pump will run for the Detergent Dose amount that you have preset. The DOSE/RECHARGE light will be on.

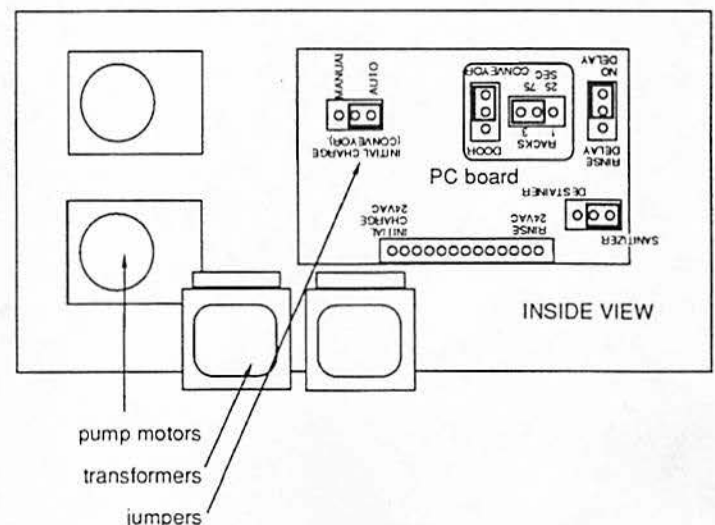

NOVA CONTROLS
LEADING THE WAY

NOVA CONTROLS FAX 408-423-6684

DISPENSER PARTS to be Ordered
Directly from NOVA CONTROLS.

CMA SYNCHRO WAREWASH CHEMICAL DISPENSING SYSTEM

SPARE PARTS

ITEM DESCRIPTION PART NUMBER

1 RINSE PUMP & MOTOR PARTS

1A	PUMP HOUSING, FRONT WITH SCREWS	03-03156-01
1B	ROLLER ASSEMBLY, RINSE (TYPE A)	03-03157-03
1C	PUMP TUBING, RINSE, SANTOPRENE	03-03109-201
	PUMP TUBING, RINSE, SILICONE	03-03109-101
1D	PUMP HOUSING, REAR, WITH SCREWS	03-03155-00
1F	MOTOR, RINSE	03-03754-01

2 DETERGENT/SANITIZER PUMP & MOTOR PARTS

2A	PUMP HOUSING, FRONT WITH SCREWS	03-03156-01
2B	ROLLER ASSEMBLY, DETERGENT (TYPE B)	03-03157-01
2C	PUMP TUBING, DETERGENT, SANTOPRENE	03-03109-221
	PUMP TUBING, DETERGENT, SILICONE	03-03109-121
	PUMP TUBING, DETERGENT, EPDM	03-03109-321
	PUMP TUBING, DETERGENT, VITON	03-03109-421
2D	PUMP HOUSING, REAR, WITH SCREWS	03-03155-00
2F	MOTOR, DETERGENT	03-03754-02

4	TRANSFORMER, RINSE POWER	03-03494-13P
5	TRANSFORMER, INITIAL CHG. POWER	03-03494-13I

7	CIRCUIT BOARD	50-03750-00
---	---------------	-------------

8	FUSE, 3AG, 1.5AMP	60-03499-00
---	-------------------	-------------

9	SECURITY PANEL W/LABEL	03-03715-02
---	------------------------	-------------

10	SECURITY TOOL	37-03356-00
----	---------------	-------------

1 RINSE

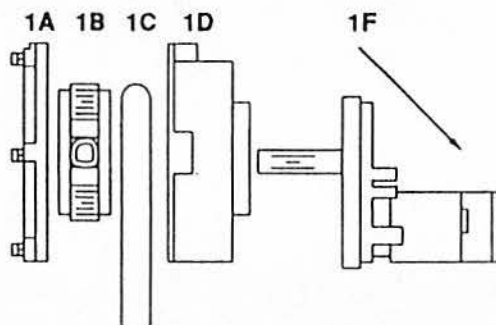

2 DETERGENT/SANITIZER

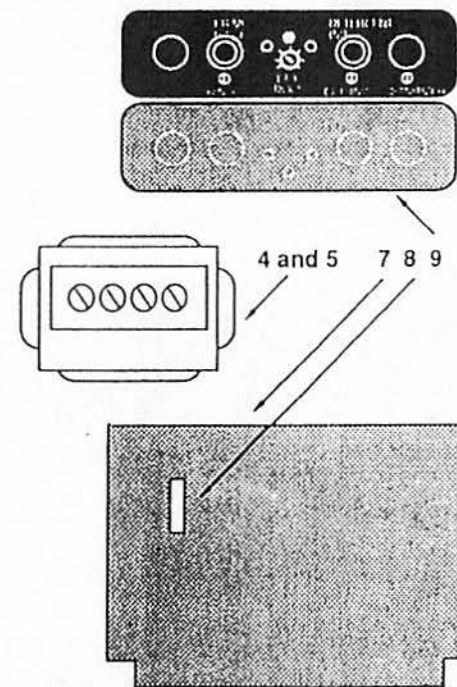
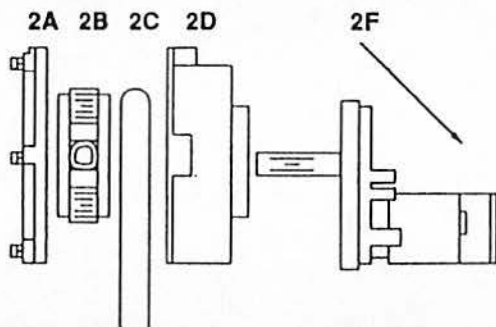

SYNCHRO Models DM-220, 230

Drawing 6/94
CMASynchroParts.pgs

Form F 2212A

13508.40

M-2 RACK SAVER ROCKER ARM ASSY.

CMA's Rack Saver System was designed to prevent damage to dish racks and to the conveyor if one was to allow racks to jam at the end of a clean dish table.

HOW IT WORKS:

1. Rt. to Lt. Flow – The left clutch bar will pivot, allowing cam drive to slip when in a jam rack situation. When the jammed rack has been cleared, the clutch bar will return to its operational position automatically.
2. Lt. to Rt. Flow – The right clutch bar will pivot and respond the *same as above*.
3. **Emergency** – If clutch spring were to break, do the following: Option #1. Replace broken spring with extra spring stored on rocker arm. Option #2. Install bolt #6 and nut #5 supplied (see diagram) into hole in clutch bar.

CAUTION: If spare bolt is installed into clutch bar, conveyor will operate, but clutch system is inoperative until spring is replaced.

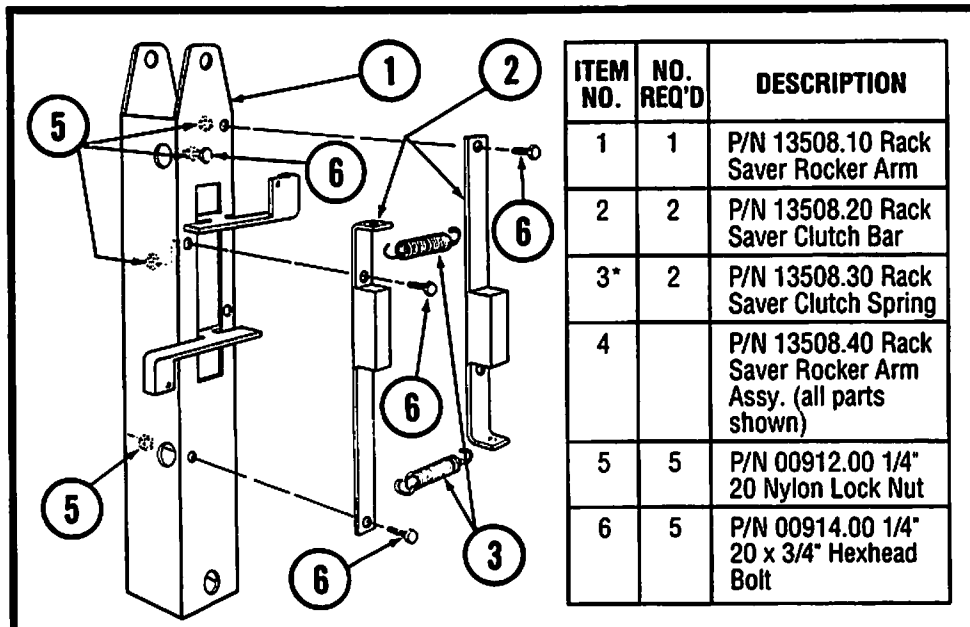
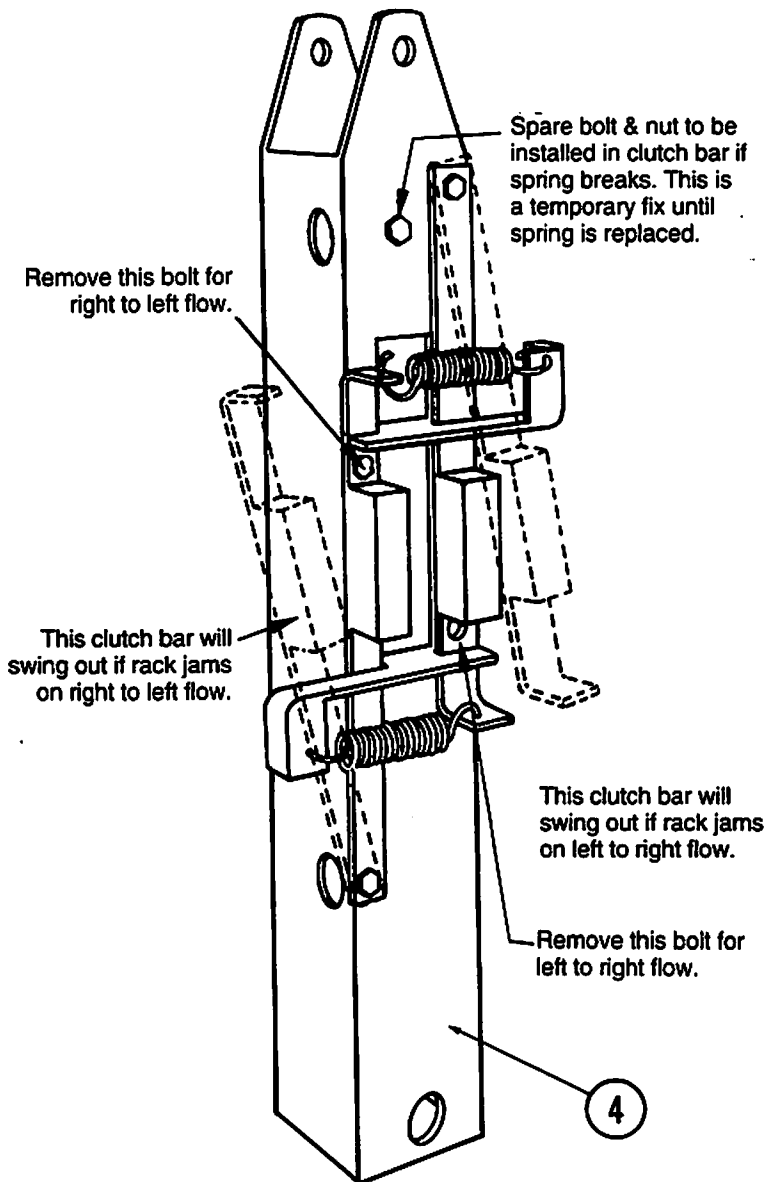

*13508.32 Rack Saver Clutch Spring Extra Strong (for long clean tables)

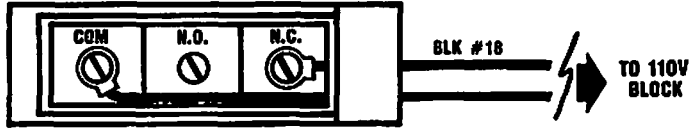

LIMIT SWITCH
COVER PLATE REMOVED

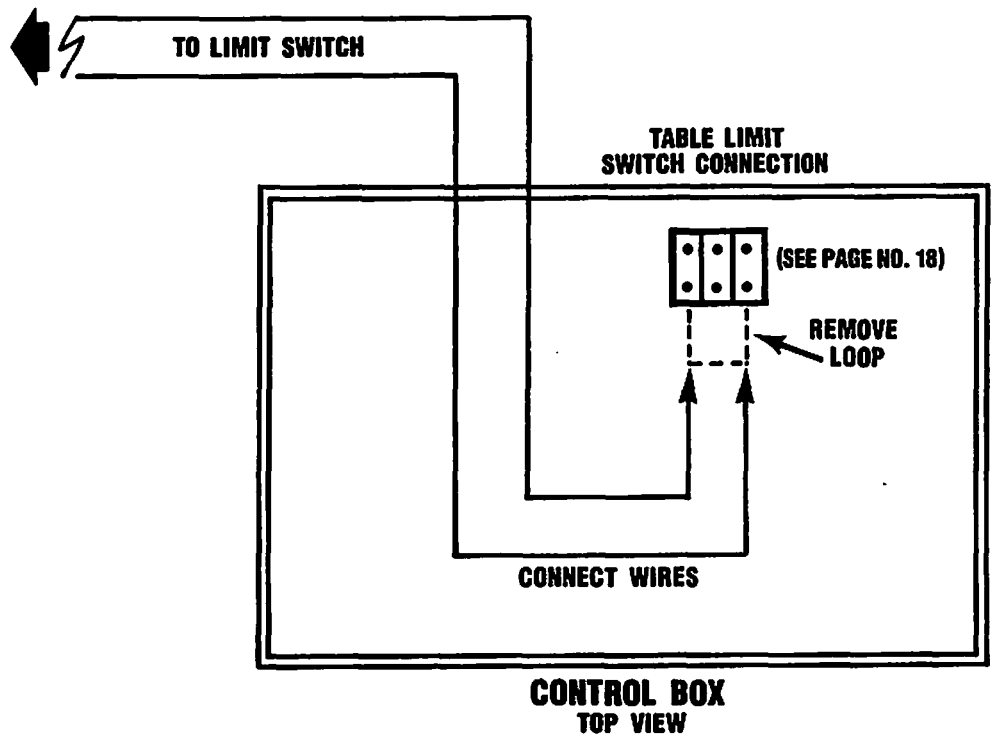
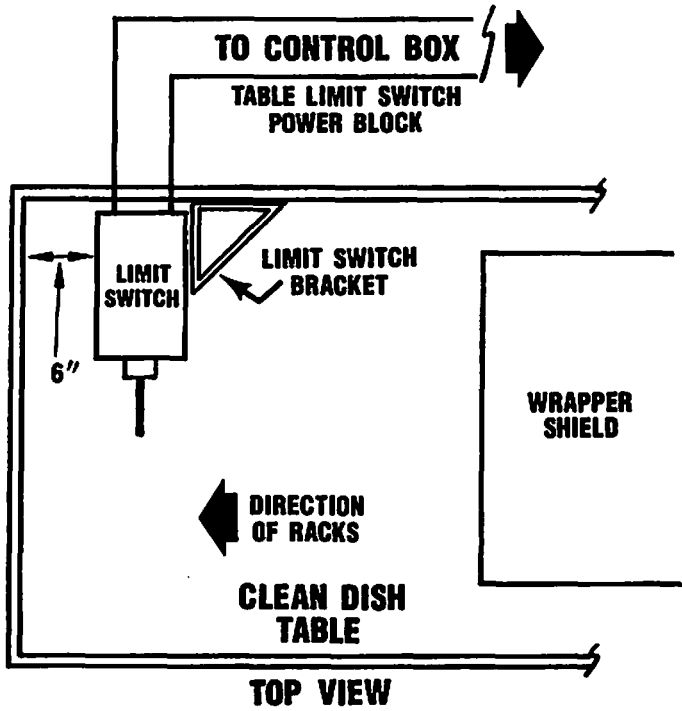

OPTIONAL TABLE LIMIT SWITCH ASSY.





M-2 OVERLOAD CONTACTOR

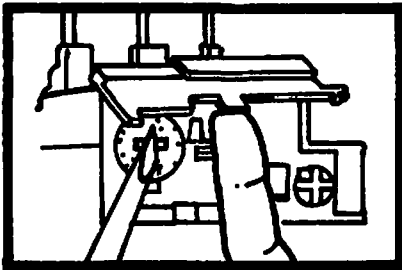

OVERLOAD ADJUSTMENT

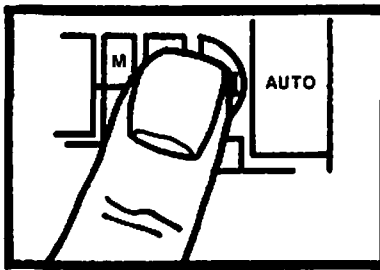

RESET FUNCTION

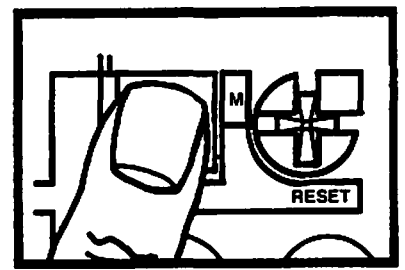

STOP FUNCTION

SETTINGS

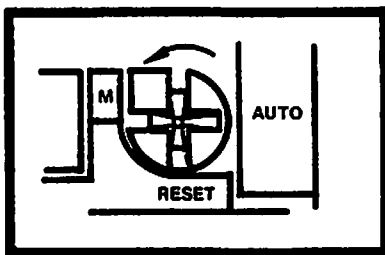

MANUAL AUTO RESET

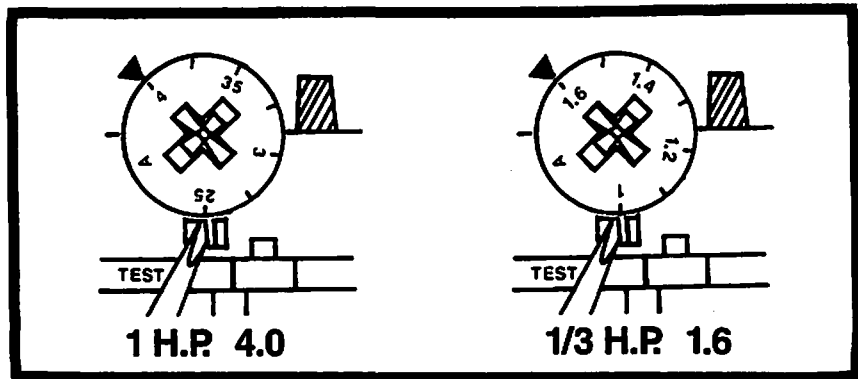

CONTROL CIRCUIT (TRIP TEST) TRIP BUTTON

THERMAL OVERLOAD REPLACEMENT

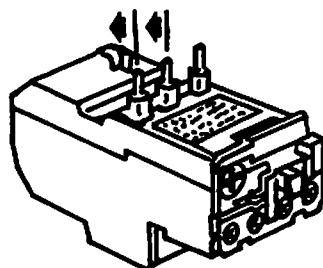
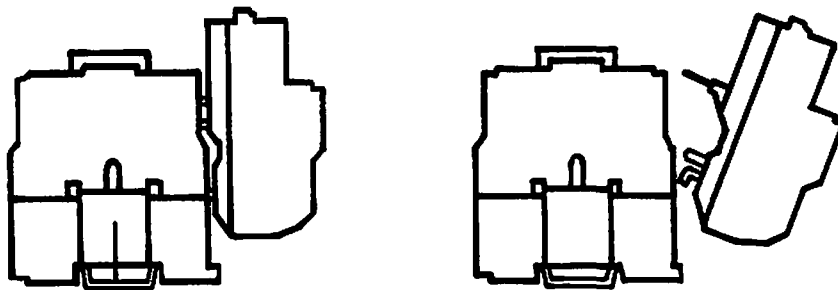

ADJUST PINS FOR
D09 CONTACTOR.



D09



CMA-44 EXPLODED VIEW SECTION

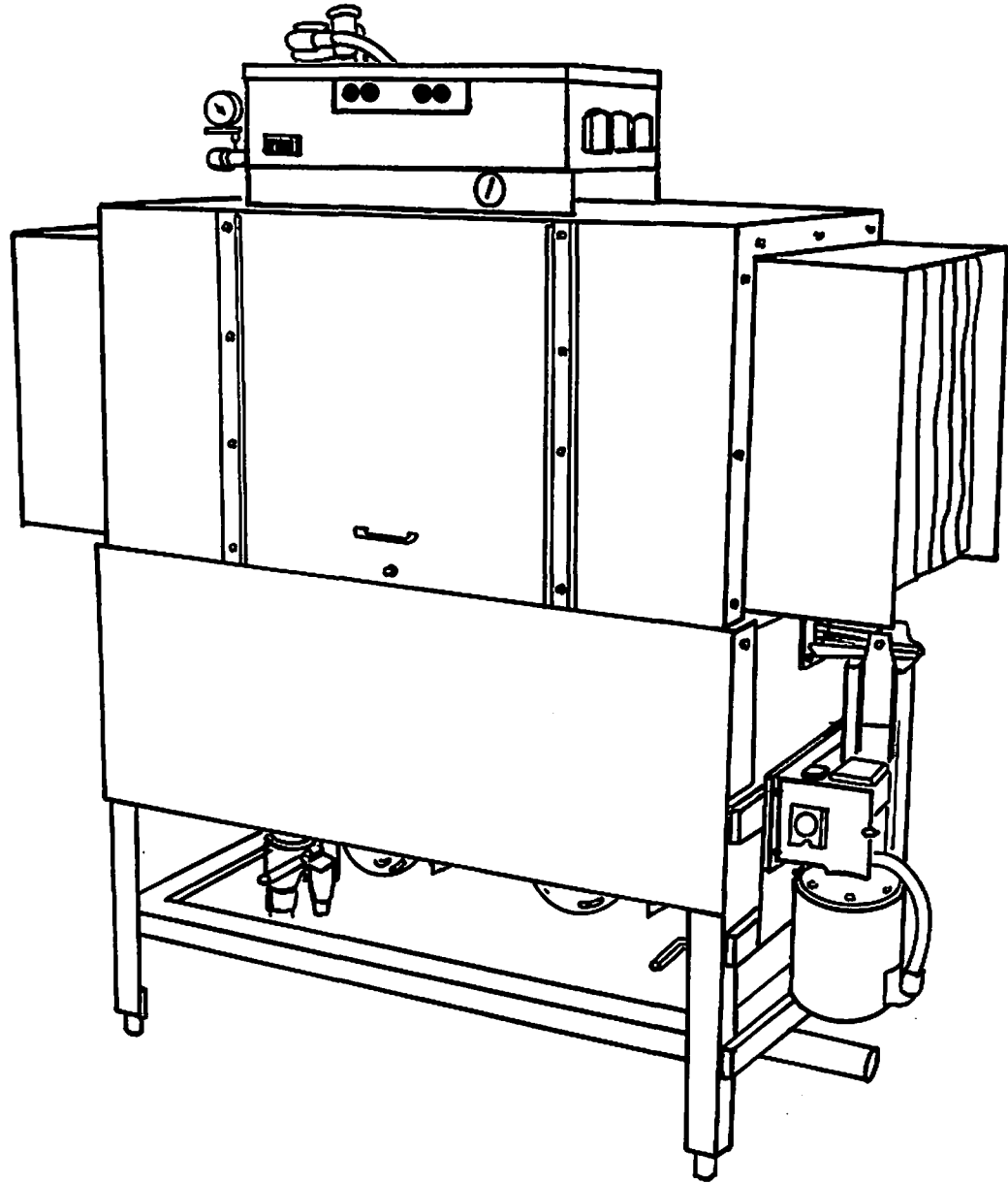



REGULAR SERVICE & MAINTENANCE CHECK LIST

9. Check the condition of the chemical tubing coming from the detergent rinse and sani buckets, up to the machine.
10. With the machine stopped, check the roller cam bearing on the conveyor. You should be able to move the outer cover of that roller cam bearing with your finger. Also, keep it well greased so that outer covering does not freeze up.
11. Check the conveyor system. Make sure the complete system is running smoothly.
12. Run two or three racks through the machine. Check the scrap overflow. While the racks are running through the machine, take a quick look under the machine to check for any drips or leaks coming from the machine or motor to make sure a pump seal is not leaking.
- 13.*Run a rack through the machine and check if 60 sec. off delay relay is operating properly. If relay is set for 60 sec., machine will shut off 60 sec. after final rinse trip switch is de-activated. If 60 sec. off delay is not working, there is an override switch located on the back of control box.
14. Run a rack through and check if power activating trip switch is operating properly. This trip switch is located on pre-wash end of machine. The trip switch activates a reed switch that is mounted on the outside of the machine under the dish table.
15. Using an all-purpose cleaner or stainless steel polish, clean up the outside of the machine to keep it looking nice.
16. Once this is done, fill out a service report and take your results to the manager.

This is a quick, preliminary check of the machine that should be done at least once a month on a regular scheduled service call with a serviceman or a scheduled appointment with a salesman going in. All of this checking does not require much in the way of tools. About the only extra item you need is a chlorine test kit or a detergent test kit. The above can be accomplished in 10-15 minutes.

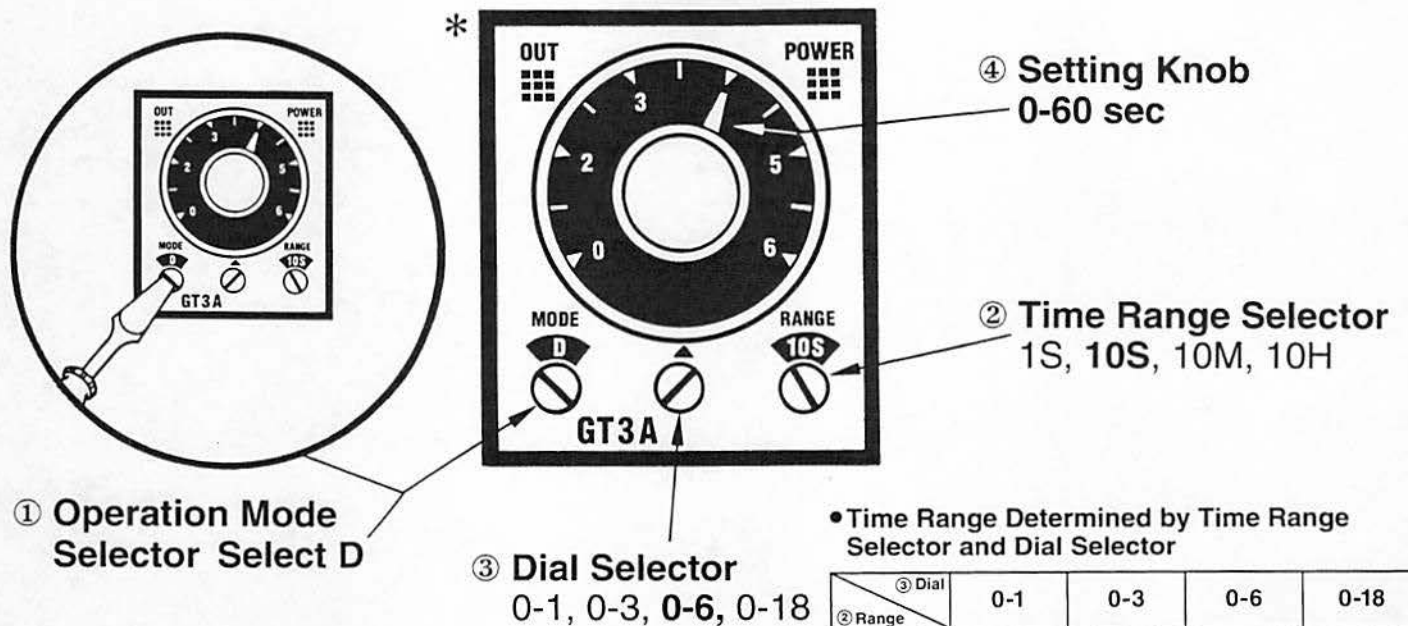

• Time Range Determined by Time Range Selector and Dial Selector

② Range \ ③ Dial	0-1	0-3	0-6	0-18
1S	0.05 sec -1 sec	0.05 sec -3 sec	0.05 sec -6 sec	0.05 sec -18 sec
10S	0.1 sec -10 sec	0.3 sec -30 sec	0.6 sec -60 sec	1.8 sec -180 sec
10M	6 sec -10 min	18 sec -3 min	30 sec -6 min	100 sec -18 min
10H	6 min -10 hours	18 min -30 hours	36 min -60 hours	108 min -180 hours

PN# 13602.00

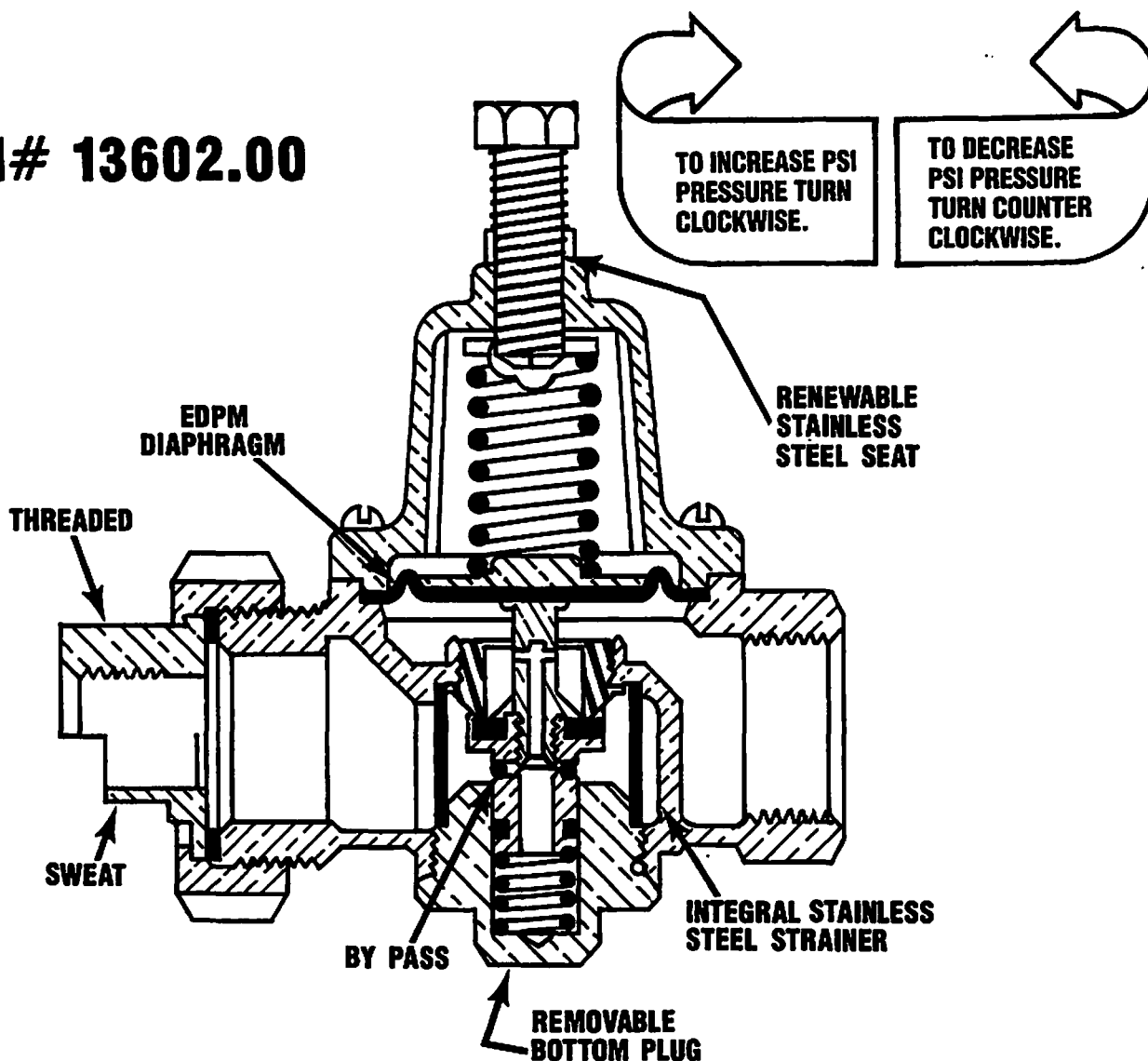

MAINTENANCE INSTRUCTIONS

1. Shut off water supply.
2. Loosen check nut and turn adjusting screw counter clockwise to relieve spring tension.
3. Remove bottom plug, 'O' ring, bottom plug spring, disc assembly and strainer.
4. Inspect all parts for dirt or scoring; clean and/or replace.
5. Valve seat can be removed, if necessary, with an allen wrench.
6. Diaphragm can be inspected or serviced by removing the spring cage.
7. Reassemble valve in reverse order and turn in adjusting screw (clockwise) for required reduced pressure adjustment.

Annual inspection of all water system safety and control valves is required and necessary. Regular inspection, testing and cleaning assures maximum life and proper product function.



FRAME SYSTEM ASSEMBLY

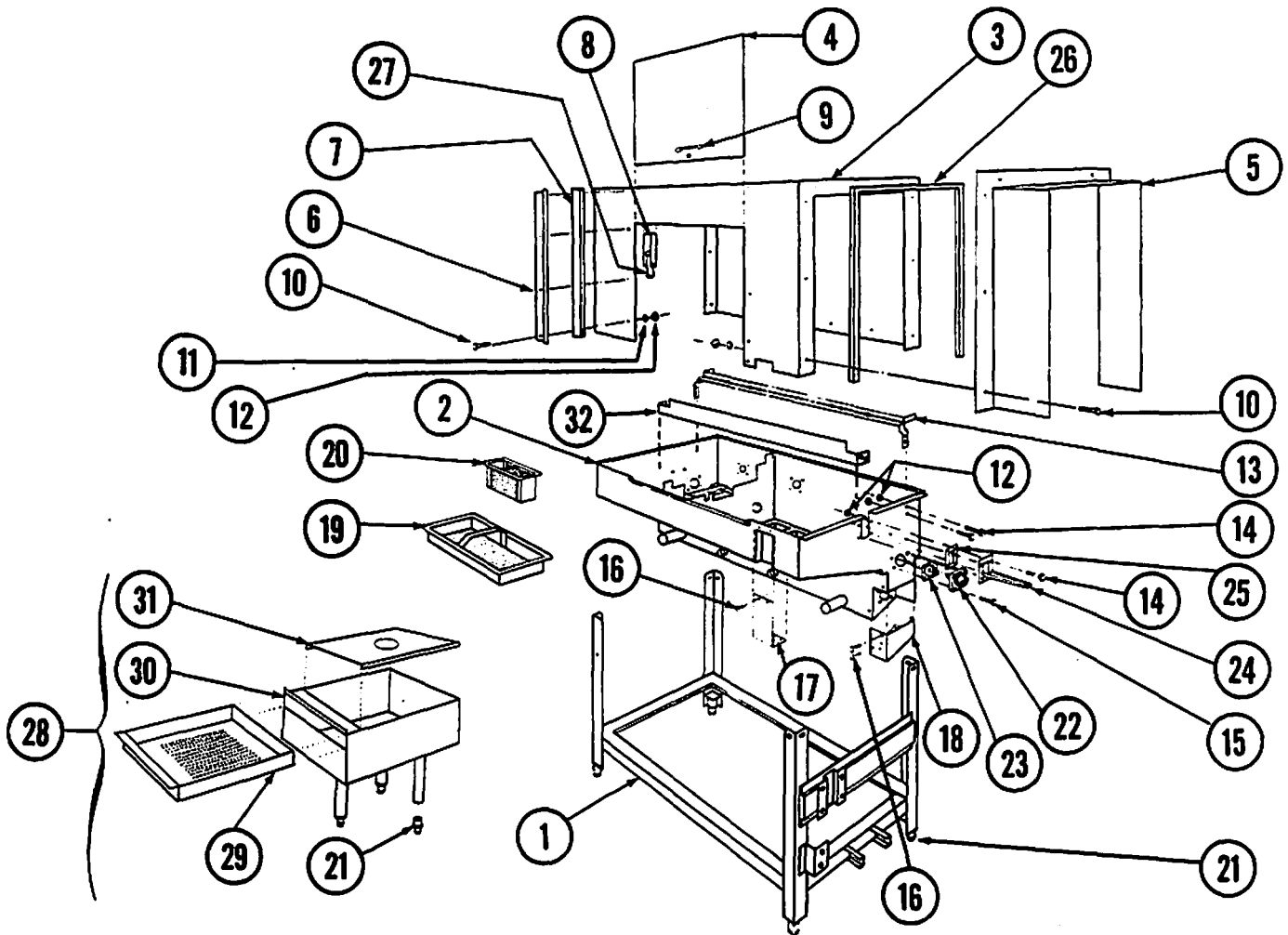

ITEM NO.	NO. REQ'D	DESCRIPTION
1	1	P/N 13903.10 M-2 Frame Stand
2	1	P/N 13902.82 M-2 L → R Pan P/N 13902.84 M-2 R → L Pan
3	1	P/N 13900.82 M-2 L → R Wrapper P/N 13900.84 M-2 R → L Wrapper
4	1	P/N 01506.00 Door (A-B-C-M-2)
5	2	P/N 13901.00 Wrapper Shield
6	2	P/N 01554.00 Door Guide
7	2	P/N 00636.10 E.Z. Glide Plastic Guide
8	1	P/N 13915.00 M-2 Door Latch Bracket
9	1	P/N 00535.30 M-2 Door Handle
10	26	P/N 00905.00 1/4"-20x1/2" Trusshead Bolt
11	60	P/N 00923.00 1/4" Brass Washer
12	52	P/N 00912.00 1/4"-20 Nylon Lock Nut
13	2	P/N 13906.00 Tray Track
14	8	P/N 00914.10 1/4"-20x5/8 Hexhead Bolt
15	4	P/N 00962.00 1/4"-20x1" Hexhead Bolt
16	4	P/N 00940.50 10"-32x3/8" Pan Head Screw

ITEM NO.	NO. REQ'D	DESCRIPTION
17	1	P/N 13408.82 M-2 Trip Switch Cover
18	1	P/N 13927.82 M-2 L → R Heater Cover P/N 13927.84 M-2 R → L Heater Cover
19	2	P/N 13910.82 M-2 Wash Rinse Strainer Basket
20	3	P/N 13910.85 M-2 Prewash Strainer Basket
21	7	P/N 01310.00 Bullet Feet
22	1	P/N 01307.00 Flange Nut
23	1	P/N 01308.00 Flange Nut Gasket
24	1	P/N 13913.00 Drip Chute
25	1	P/N 13542.00 Drip Chute Gasket
26	4	P/N 03705.00 Foam Tape
27	1	P/N 13701.00 Door Latch
28	1	P/N 01560.00 3 Leg Scrap Trap*
29	1	P/N 01562.00 Scrap Trap Drawer
30	1	P/N 01560.51 Scrap Trap Body
31	1	P/N 01561.00 Scrap Trap Lid
32	1	P/N 13922.00 Center Support Rail

* 28 includes: 29 and 30.



CONVEYOR SYSTEM ASSEMBLY

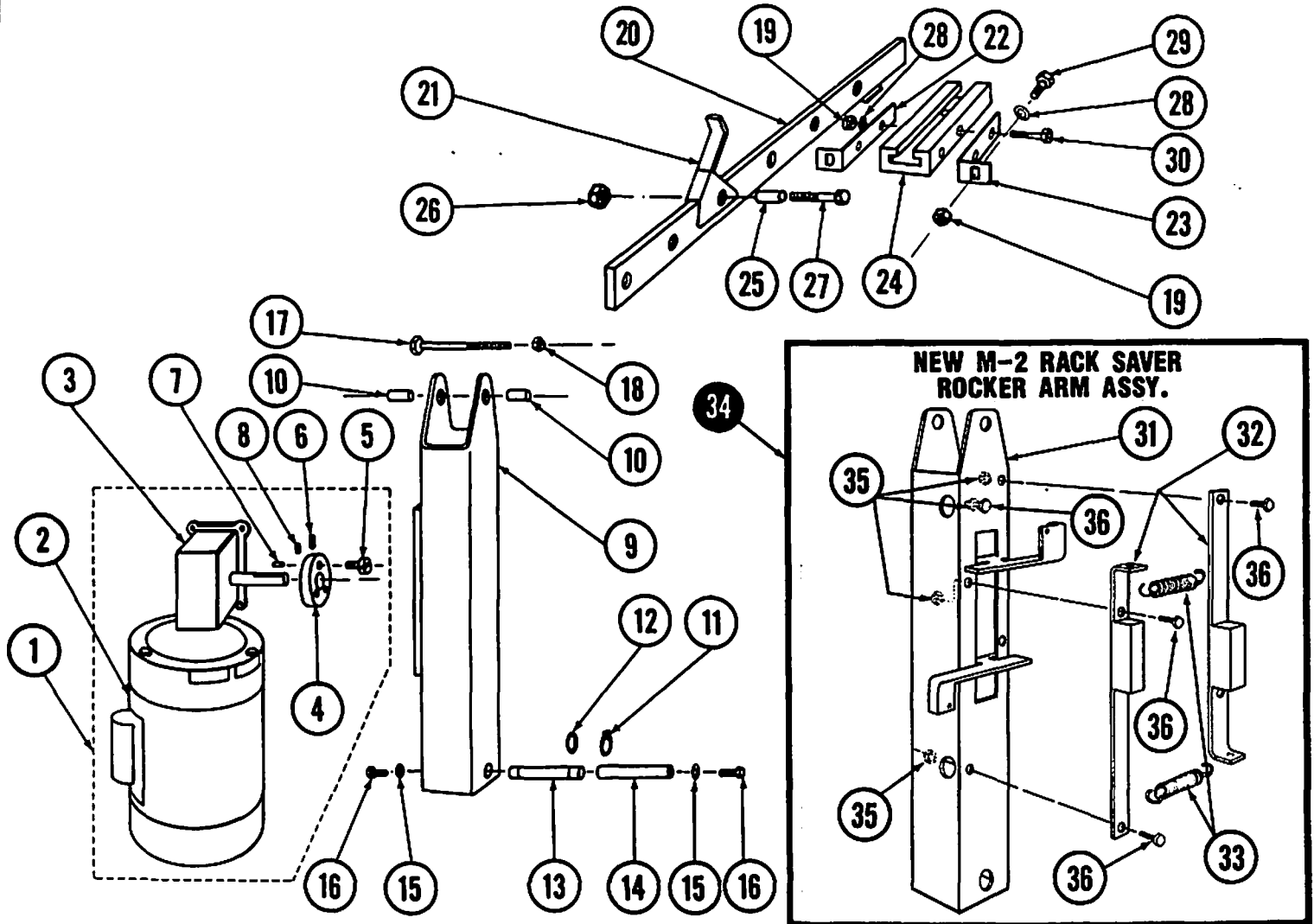

ITEM NO.	NO. REQ'D	DESCRIPTION
1	1	P/N 13570.20, M-2 60HZ Conv. Dr. Assy.*
2	1	P/N 13501.85, Motor 1/3HP 208/220 60HZ 3PH
3	1	P/N 13504.00, Gear Reducer
4	1	P/N 13505.10, Rocker Arm Cam
5	1	P/N 13507.50, Cam Bearing SS
6	1	P/N 13816.00, 3/16"-18x1/2" Socket Set Screw
7	1	P/N 13505.20, Keyway Cam
8	1	P/N 00935.00, 1/4"-20x1/4" Set Screw
9	1	P/N 13508.00, Rocker Arm
10	2	P/N 13513.10, Rocker Arm Spacer
11	2	P/N 13509.52, 7/8" I.D. Lock Ring
12	2	P/N 13509.53, 1" I.D. Brass Washer
13	1	P/N 13509.51, Rocker Arm Shaft Bearing
14	1	P/N 13510.10, Bearing Shaft M-2
15	2	P/N 00922.00, 1/4" Lock Star Washer
16	2	P/N 00914.00, 1/4"-20x3/4" Hexhead Bolt
17	1	P/N 13808.00, 1/2"-13x3 1/2" Hexhead Bolt
18	1	P/N 13809.00, 1/2"-13 Nylon Lock Nut

ITEM NO.	NO. REQ'D	DESCRIPTION
19	1	P/N 00912.00, 1/4"-20 Nylon Lock Nut
20	1	P/N 13514.85, M-2 Conveyor Bar
21	5	P/N 13515.00, Conveyor Dog SS
22	1	P/N 13514.82, M-2 Left Conveyor Bar Bracket
23	1	P/N 13514.84, M-2 Right Conveyor Bar Bracket
24	1	P/N 13521.50, M-2 Conveyor Bar Slide Bearing
25	10	P/N 13520.00, Conveyor Dog Bearing
26	5	P/N 13806.00, 3/8" Nylon Lock Nut
27	5	P/N 13818.00, 3/8"-16x1 3/4" Hexhead Bolt
28	2	P/N 00924.00, 1/4" S.S. Washer
29	2	P/N 00914.10, 1/4"-20x5/8" Hexhead Bolt
30	1	P/N 00903.00, 1/4"-20x1 3/4" Hexhead Bolt
31	1	P/N 13508.10, Rack Saver Rocker Arm
32	2	P/N 13508.20, Rack Saver Clutch Bar
33**	2	P/N 13508.30, Rack Saver Clutch Spring
34	1	P/N 13508.40, Complete Rack Saver Rocker Arm Assy.
35	4	P/N 00912.00, 1/4" 20 Nylon Lock Nut
36	4	P/N 00914.00, 1/4" - 20x3/4" Hexhead Bolt

* 1 includes 2 through 8.

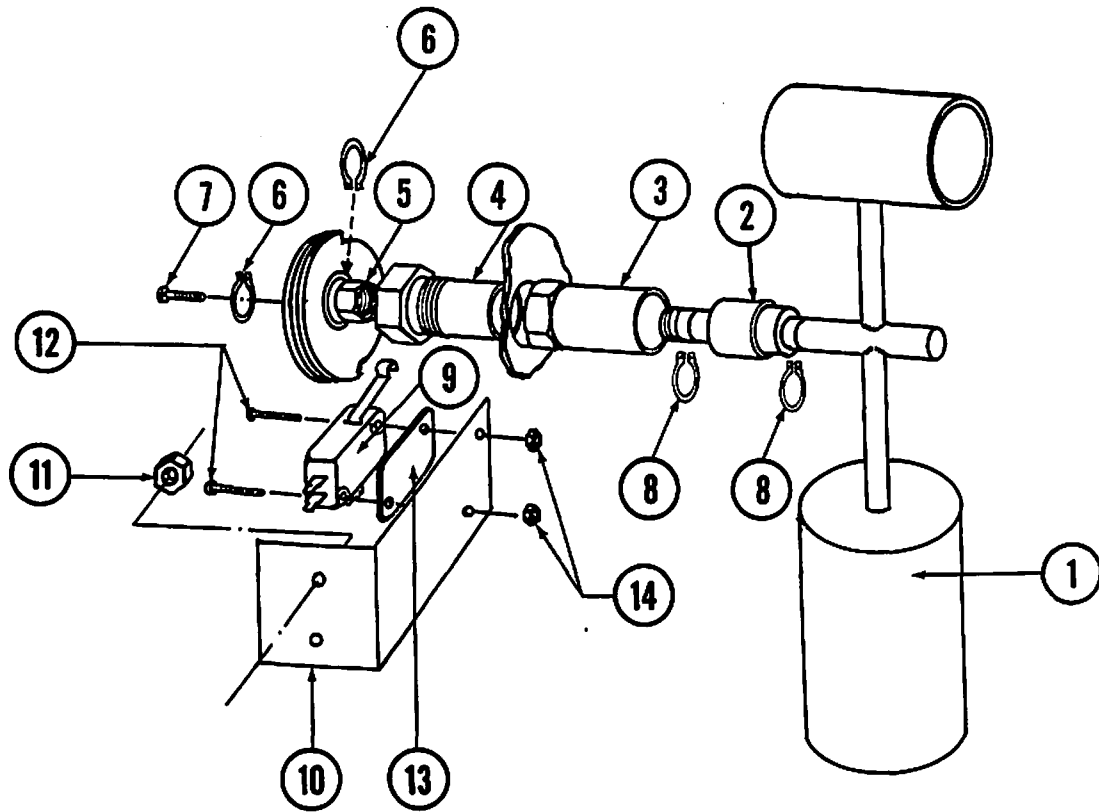

ITEM NO.	NO. REQ'D	DESCRIPTION
1	1	P/N 13408.85 Trip Switch Assy.*
2	1	P/N 13424.50 Trip Switch Bearing
3	1	P/N 13455.00 Switch Sleeve Brass
4	1	P/N 13435.00 Bearing Nut
5	1	P/N 13409.51 Shaft Extender - Threaded
6	2	P/N 13411.00 Lock Ring
7	1	P/N 13825.00 8 - 32x1" Pan Head Screw

ITEM NO.	NO. REQ'D	DESCRIPTION
8	2	P/N 13411.50 Large Ring
9	1	P/N 00411.00 Micro Switch
10	1	P/N 13414.82 M-2 Micro Switch Support Bracket
11	2	P/N 00965.00 6"-32 Nylon Lock
12	2	P/N 13826.00 4"-40x5/8" Pan Screw
13	1	P/N 13418.10 Insulator Spacer
14	2	P/N 13826.50 4"-40 Hexhead

* 1 includes 2, 3, 4 & 8.



PLUMBING SYSTEM ASSEMBLY LOW TEMP

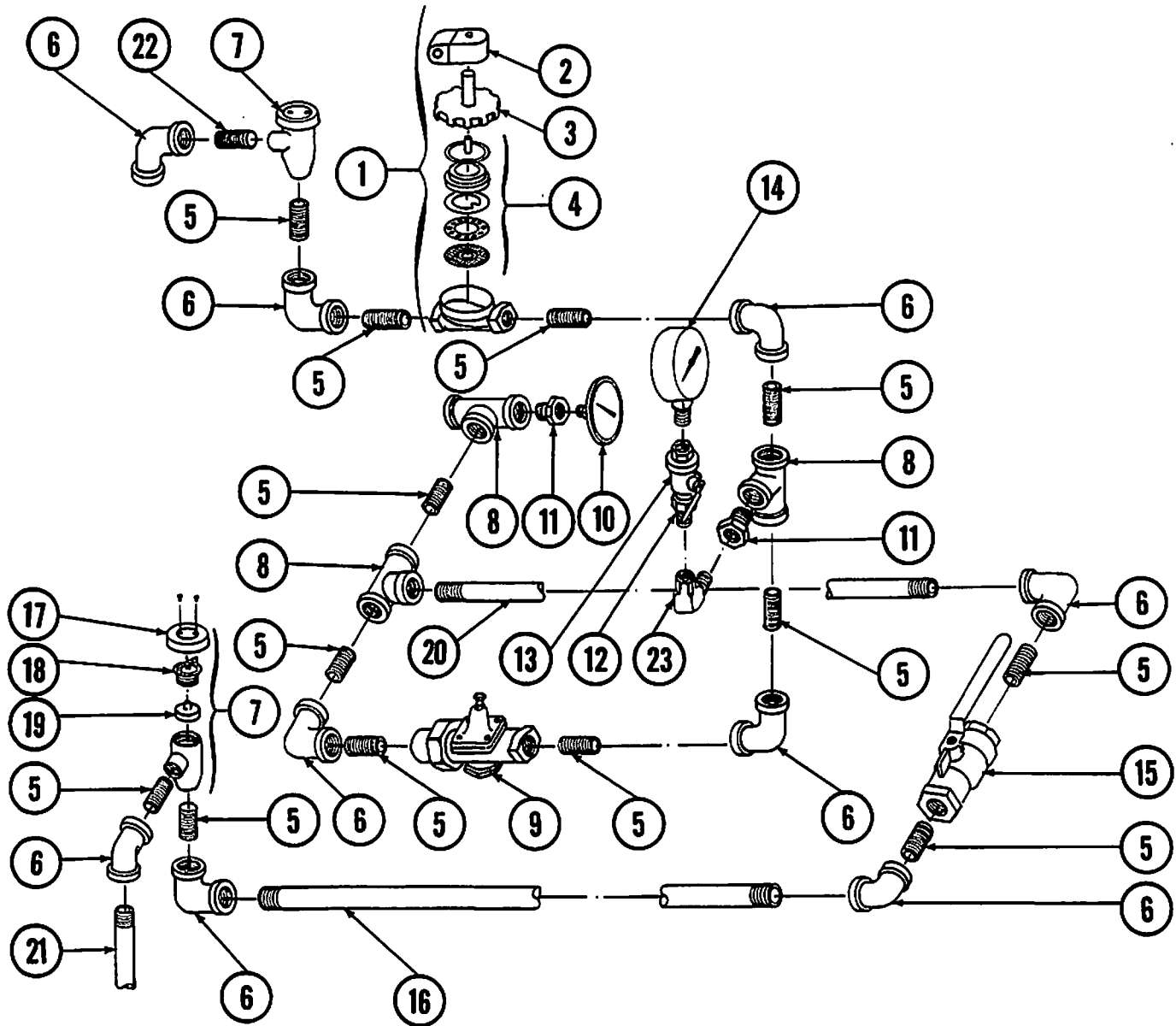

ITEM NO.	NO. REQ'D	DESCRIPTION
1	1	P/N 00705.00 3/4" Water Solenoid Valve JE*
2	1	P/N 00738.15 3/4" Solenoid 220V JE
3	1	P/N 00705.20 3/4" Water Solenoid Valve Bonnet JE
4	1	P/N 00706.00 3/4" Water Solenoid Valve Repair Kit JE
5	13	P/N 00701.00 3/4" Close Nipple Brass
6	7	P/N 13633.00 3/4" 90 Deg ELL. FxF Brass
7	2	P/N 00710.50 3/4" Vacuum Breaker-Watts*
8	2	P/N 00716.50 3/4"x3/4"x3/4" FxFxF Brass Tee
9	1	P/N 13602.00 3/4" Pressure Regulator
10	1	P/N 00120.00 Thermometer
11	2	P/N 00769.00 3/4"x1/4" Brass Bushing
12	1	P/N 41011.00 1/4" Close Nipple Brass

ITEM NO.	NO. REQ'D	DESCRIPTION
13	1	P/N 41010.02 1/4" Mini Ball Valve
14	1	P/N 13605.00 Pressure Gauge
15	1	P/N 13027.00 3/4" Ball Valve
16	1	P/N 13656.82 3/4"x10 1/2" Brass Nipple
17	2	P/N 00739.50 3/4"x1/2" Vac. Breaker Cap SS
18	2	P/N 00735.60 3/4" Vac. Breaker Bonnet Brass
19	2	P/N 00735.00 3/4" Vac. Breaker Repair Kit Watts
20	1	P/N 13656.85 3/4"x 12" Brass Nipple
21	1	P/N 13656.84 3/4"x4 1/2" Brass Nipple
22	1	P/N 13635.00 3/4"x2" Nipple SS
23	1	P/N 40137.00 1/4" Street Elbow

* Item 1 includes: 2, 3 and 4.

* Item 7 includes: 17, 18 and 19.



PLUMBING SYSTEM ASSEMBLY HIGH TEMP

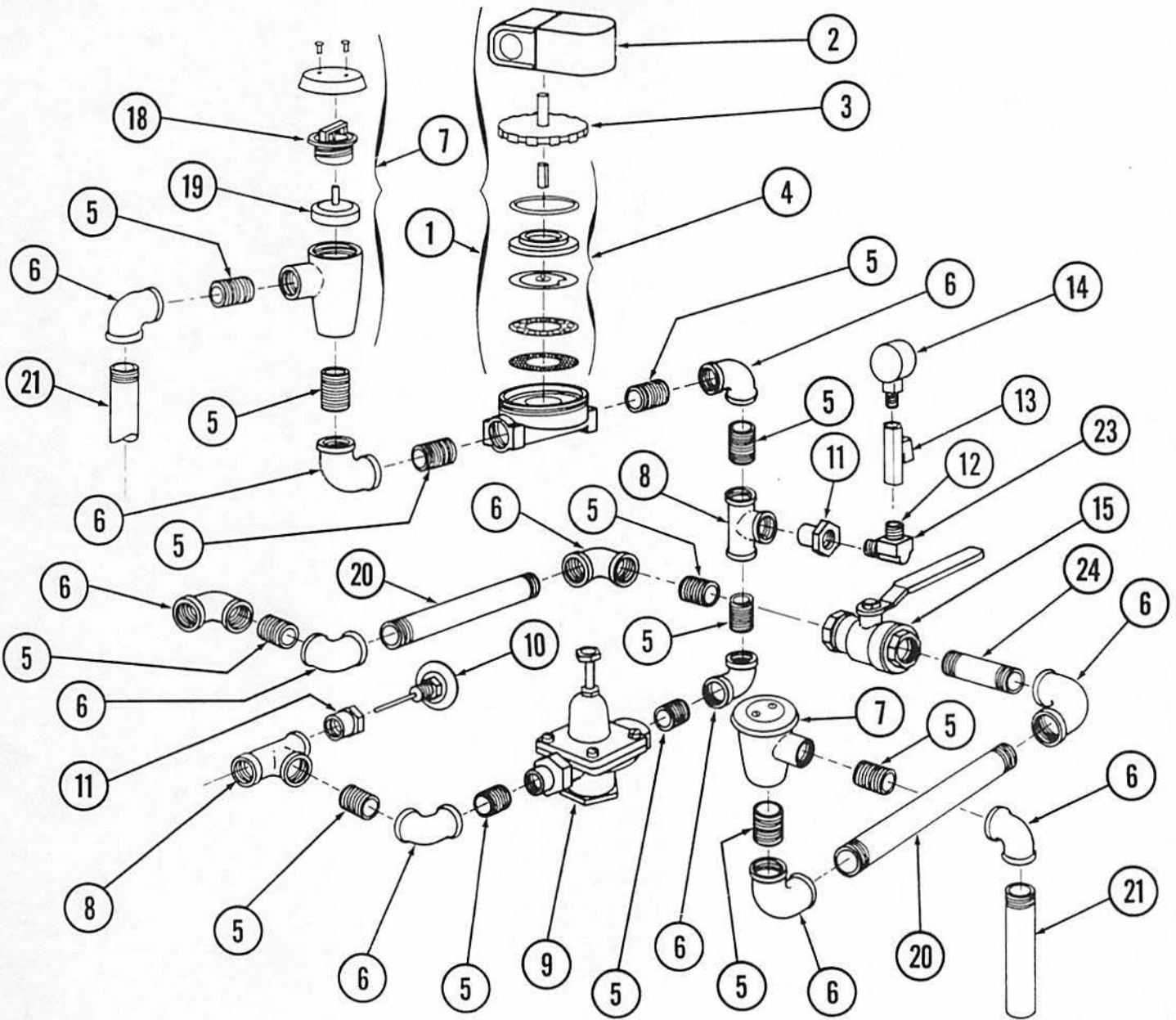

ITEM NO.	NO. REQ'D	DESCRIPTION
1	1	P/N 00705.00 3/4" Water Solenoid Valve JE*
2	1	P/N 00738.15 3/4" Solenoid 220V JE
3	1	P/N 00705.20 3/4" Water Solenoid Valve Bonnet JE
4	1	P/N 00706.00 3/4" Water Solenoid Valve Repair Kit JE
5	12	P/N 00701.00 3/4" Close Nipple Brass
6	10	P/N 13633.00 3/4" 90 Deg ELL FxF Brass
7	2	P/N 00710.50 3/4" Vacuum Breaker-Watts*
8	2	P/N 00716.50 3/4"x3/4"x3/4" FxFxF Brass Tee
9	1	P/N 13602.00 3/4" Pressure Regulator
10	1	P/N 00120.00 Thermometer
11	2	P/N 00769.00 3/4"x1/4" Brass Bushing
12	1	P/N 41011.00 1/4" Close Nipple Brass

ITEM NO.	NO. REQ'D	DESCRIPTION
13	1	P/N 41010.02 1/4" Mini Ball Valve
14	1	P/N 13605.00 Pressure Gauge
15	1	P/N 13027.00 3/4" Ball Valve
16	1	P/N 13656.82 3/4"x10 1/2" Brass Nipple
17	2	P/N 00739.50 3/4"x1/2" Vac. Breaker Cap SS
18	2	P/N 00735.60 3/4" Vac. Breaker Bonnet Brass
19	2	P/N 00735.00 3/4" Vac. Breaker Repair Kit Watts
20	1	P/N 13656.85 3/4"x1/2" Brass Nipple
21	1	P/N 13656.84 3/4"x4 12" Brass Nipple
22	1	P/N 13635.00 3/4"x2" Nipple SS
23	1	P/N 40137.00 1/4" Street Elbow
24	1	P/N 00781.00 Nipple 3/4 x3-1/2"

* Item 1 includes: 2, 3 and 4.

* Item 7 includes: 17, 18 and 19.



SPRAY SYSTEM ASSEMBLY

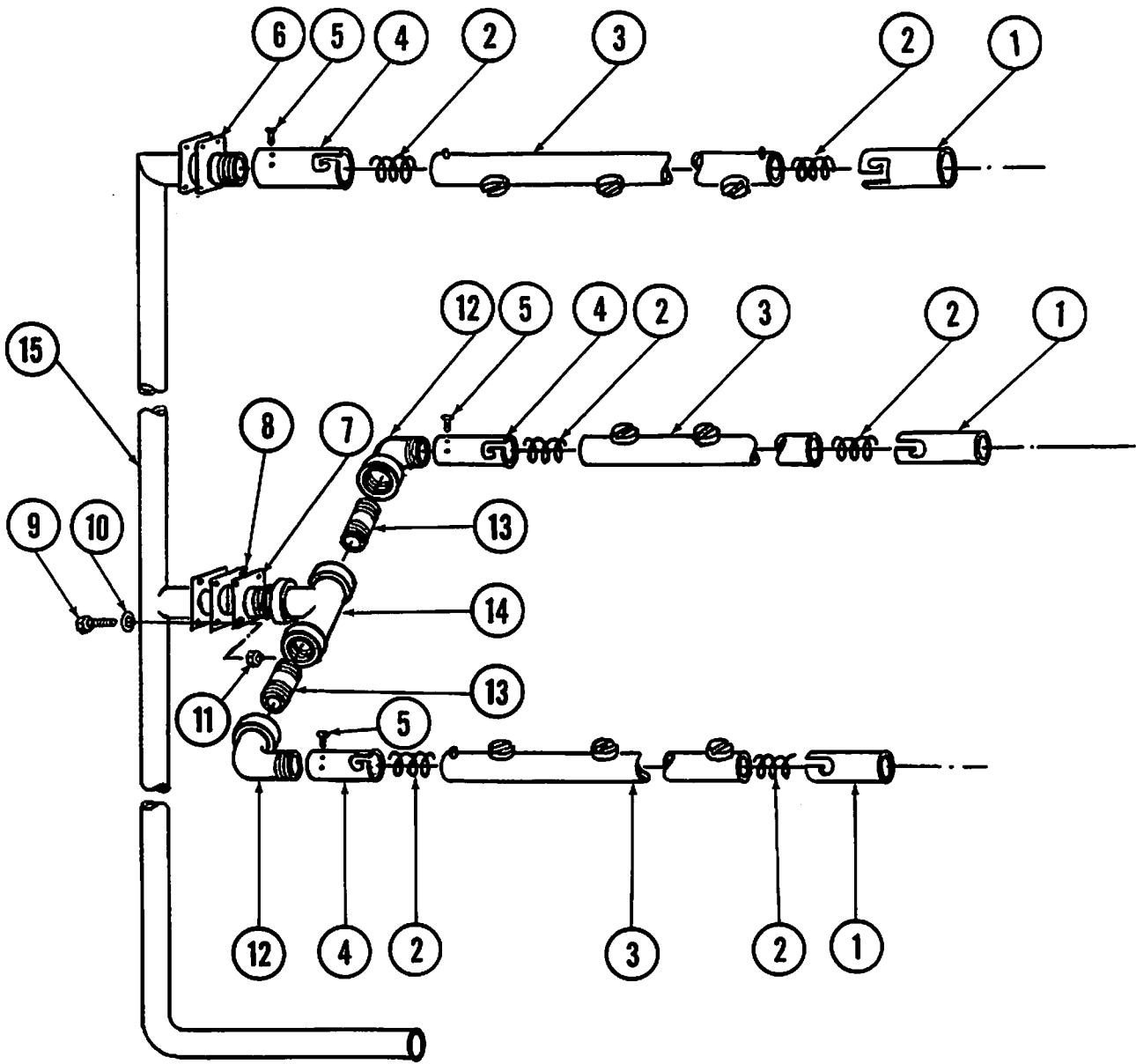

ITEM NO.	NO. REQ'D	DESCRIPTION
1	6	P/N 13305.00 Spray Arm End Cap SS
2	12	P/N 13306.55 Spray Arm Extension Spring
3	6	P/N 13303.70 Spray Arm Universal
4	6	P/N 13306.20 Spray Arm Extender
5	12	P/N 00906.00 1/4" - 20 x 1/2" Hexhead Bolt
6	2	P/N 13306.51 Spray Arm Adapter Long
7	2	P/N 13306.50 Spray Arm Adapter Short
8	8	P/N 04306.00 Square Manifold Gasket

ITEM NO.	NO. REQ'D	DESCRIPTION
9	16	P/N 00914.00 1/4" - 20 x 3/4" Hexhead Bolt
10	32	P/N 00923.00 1/4" Brass Washer
11	16	P/N 00912.00 1/4" - 20 Nylon Lock Nut
12	4	P/N 13633.50 3/4" 90° EII SS
13	4	P/N 13639.00 3/4" Close Nipple SS
14	2	P/N 13611.00 3/4" Tee FXXFX SS
15	2	P/N 13301.00 M-1 & M-2 Manifold



FINAL RINSE SYSTEM

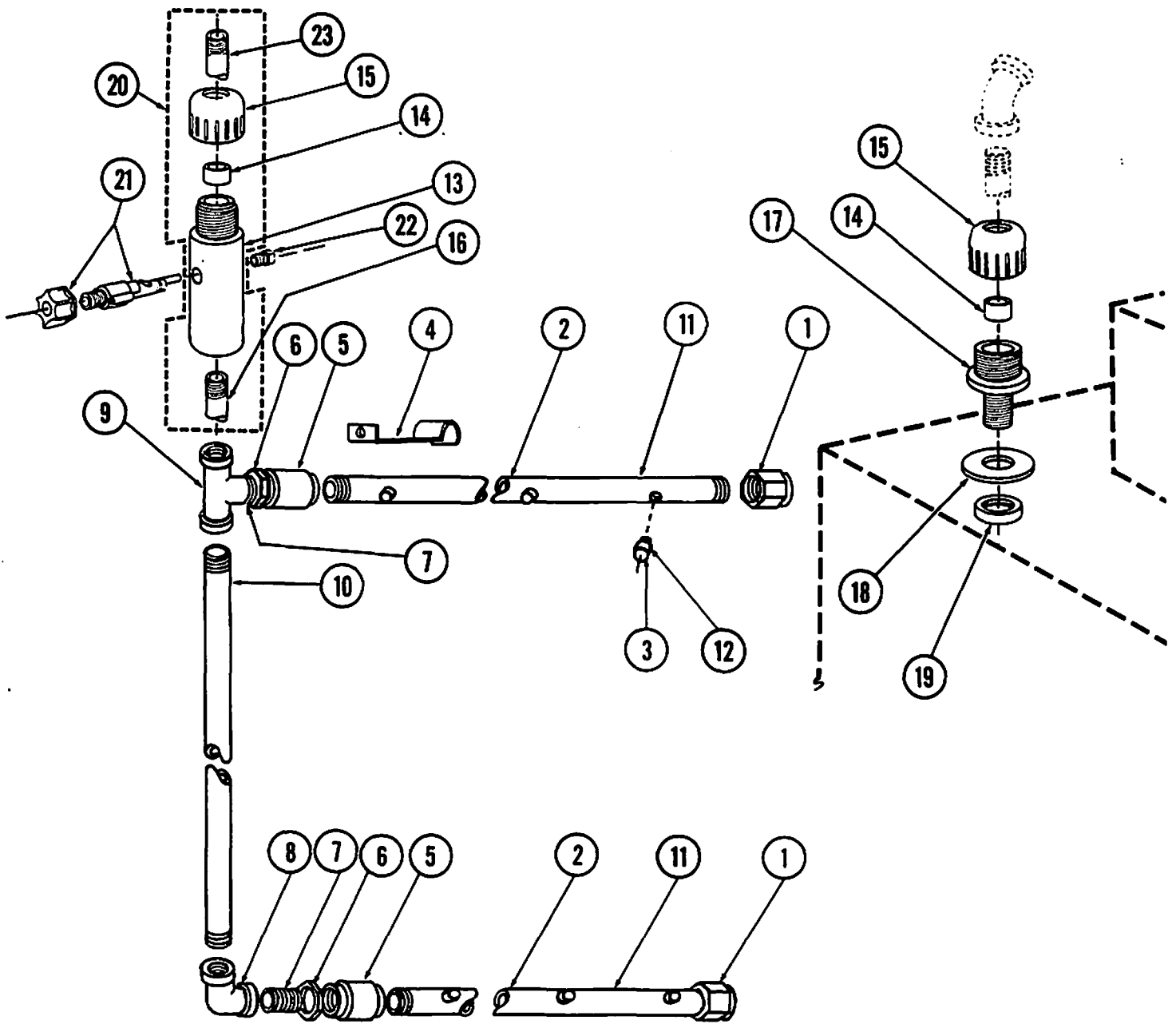

ITEM NO.	NO. REQ'D	DESCRIPTION
1	2	P/N 13310.00, 1/2" Brass Cap
2	2	P/N 13304.30, SS Final Rinse Spray Arm Low Temp
3	8	P/N 13304.50, Final Rinse Spray Tip CPVC Low Temp
4	3	P/N 13304.53, Long Support Bracket
5	2	P/N 13618.00, 1/2" Coupling SS
6	4	P/N 00721.00, 1/2" Jump Nut
7	2	P/N 13629.00, 1/2" Close Nipple SS
8	1	P/N 13628.00, 1/2" 90° EIL FXF SS
9	1	P/N 13630.00, 1/2" Tee FXFXF SS
10	1	P/N 13307.00, Final Rinse Down Tube SS
11	2	P/N 13304.82, SS Final Rinse S.A. High Temp
12	8	P/N 13304.55, SS Final Rinse Spray Tip High Temp

ITEM NO.	NO. REQ'D	DESCRIPTION
13	1	P/N 13669.00, Mixing Chamber Body
14	2	P/N 13656.20, 3/4" IPS Comp. Gasket
15	2	P/N 13656.30, 3/4" IPS Comp. Cap
16	1	P/N 13629.82, Nipple SS 1/2"x5/8"
17	1	P/N 13652.00, Collar Insert Water Inlet
18	1	P/N 00752.85, Collar Gasket
19	1	P/N 13606.00, 3/4" Jamb Nut Brass
20	1	P/N 13656.00, Mixing Chamber Assy.
21	1	P/N 13658.00, Chemical Inlet Check Valve
22	1	P/N 13655.75, 1/8" CPVC Plug
23	1	P/N 13656.10, Inlet Tube



DRAIN SYSTEM ASSEMBLY

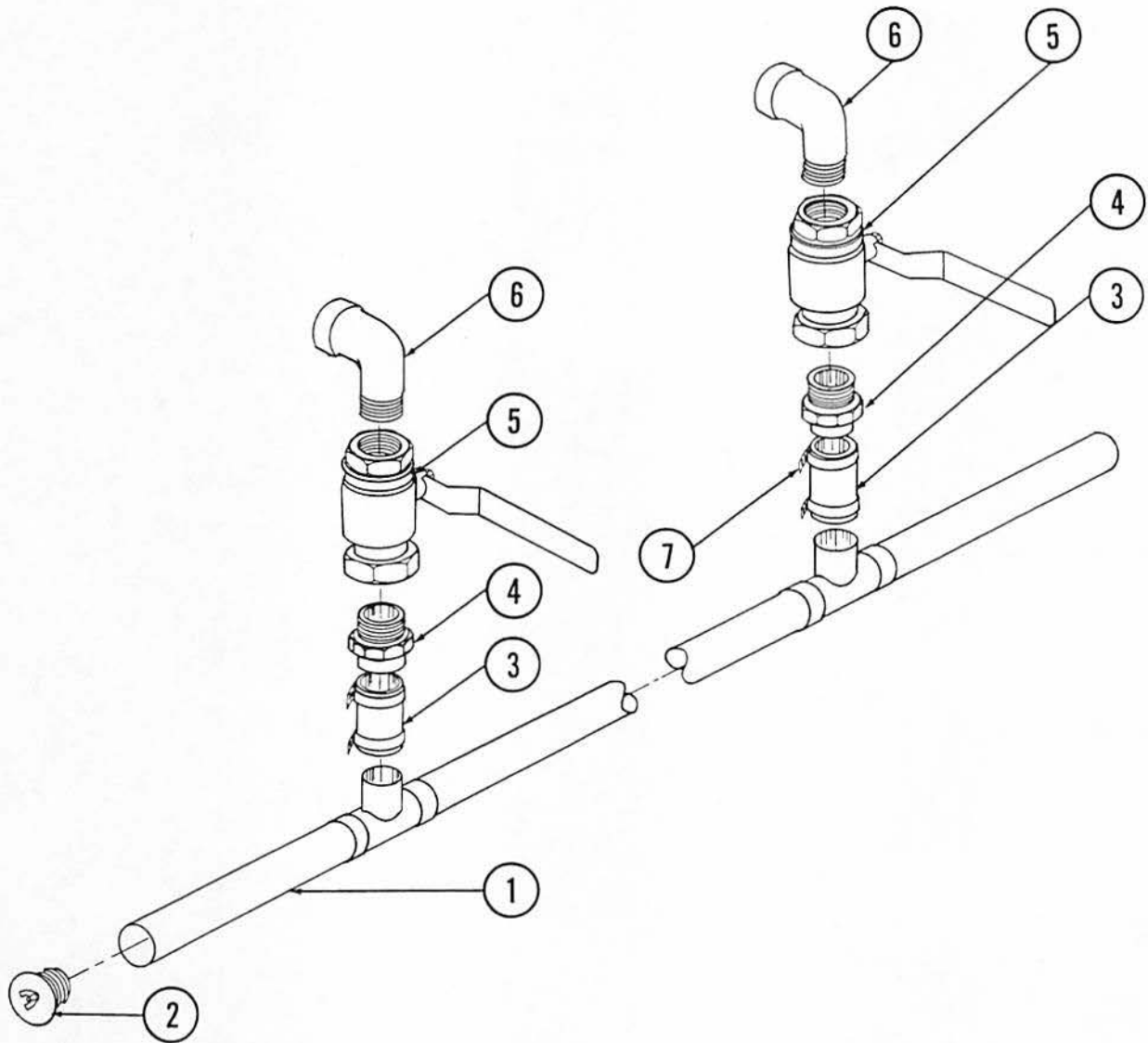

ITEM NO.	NO. REQ'D	DESCRIPTION
1	1	P/N 13001.85 M-2 Drain Manifold
2	1	P/N 13024.00 Dynamite Plug
3	2	P/N 13020.20 Hose Drain Manifold Valve
4	2	P/N 00766.50 1-1/2" CXMIP Adapter
5	2	P/N 13002.00 1-1/2" Ball Valve
6	2	P/N 00767.10 1-1/2" Brass Street Ell
7	4	P/N 50109.00 Hose Clamp #28 SS



WATER CONTROL SYSTEM

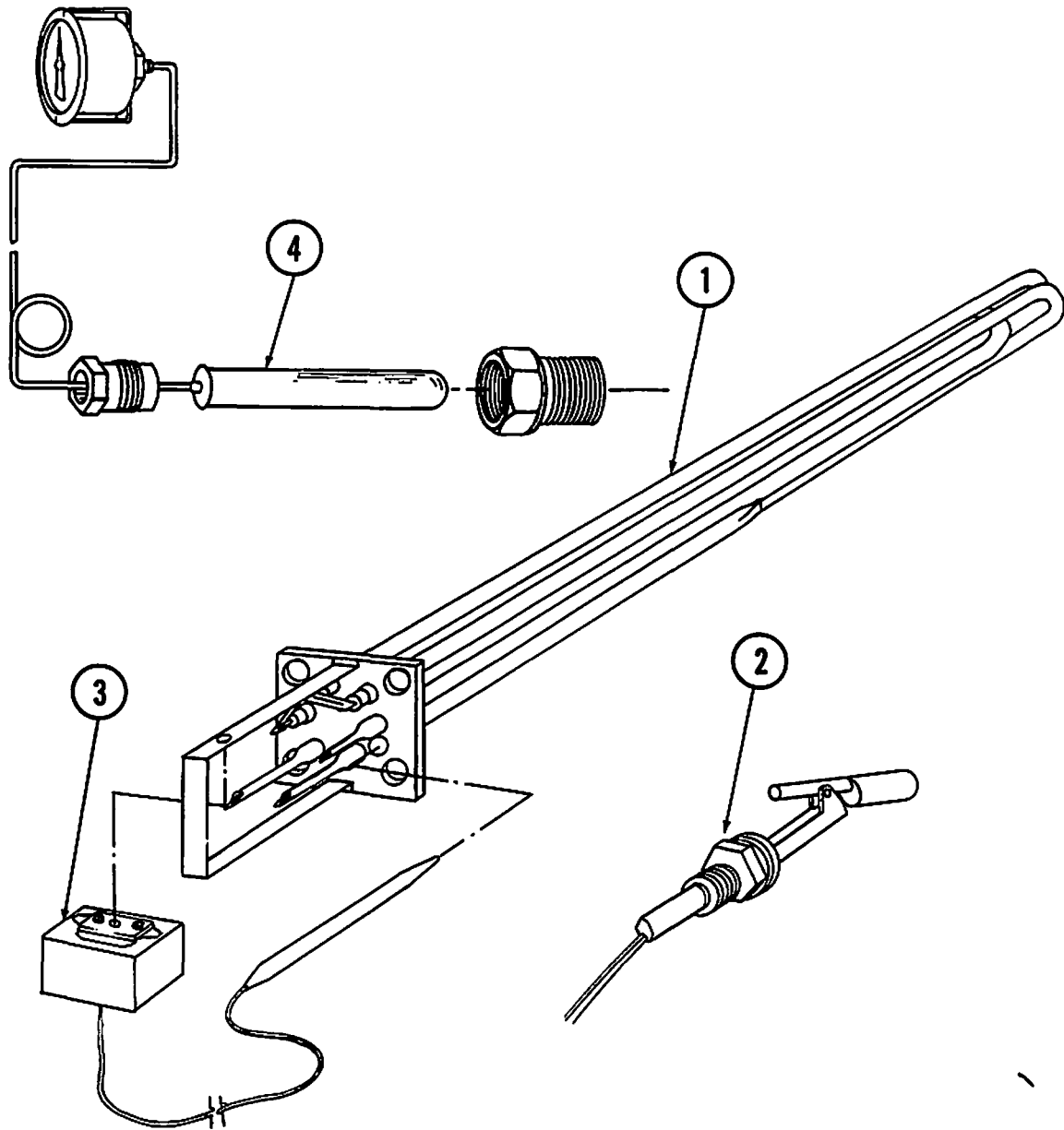

ITEM NO.	NO. REQ'D	DESCRIPTION
1	1	P/N 13417.77 M-2 Immersion Htr. 3 PH, 240V, 10KW
2	1	P/N 13463.00 M-2 Liquid Level Switch
3	1	P/N 13417.85 M-2 10 KW Heater Thermostat
4	1	P/N 03202.00 Thermometer



PUMP SYSTEM ASSEMBLY

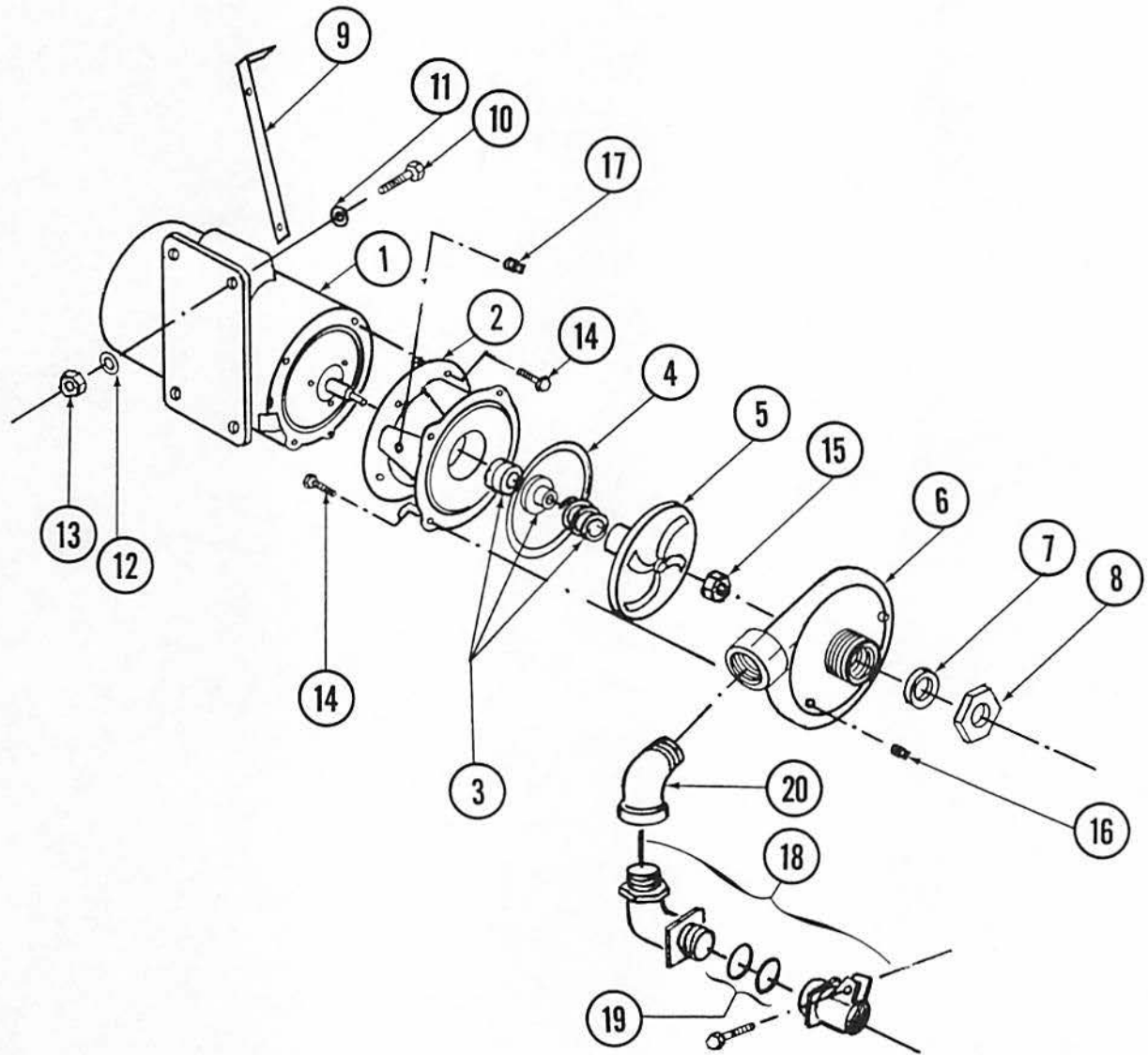

ITEM NO.	NO. REQ'D	DESCRIPTION
1	2	P/N 00201.85 Pump Motor 1 HP, 3 PH, 60 HZ, 220V
2	2	P/N 03224.00 Pump Base Mount
3	2	P/N 00206.00 Pump Seal Kit
4	2	P/N 03226.00 Pump "O" Ring Gasket
5	2	P/N 03222.85 M-2 Water Pump Impeller
6	2	P/N 04206.00 Pump Cover
7	2	P/N 00208.00 Slip Joint Nut Gasket
8	2	P/N 04204.00 Compression Nut 2.5"
9	2	P/N 13916.00 Motor Support Bracket
10	4	P/N 00906.00 1/4" - 20 x 1/2" Hexhead Bolt
11	4	P/N 00922.00 1/4" Lock Star Washer

ITEM NO.	NO. REQ'D	DESCRIPTION
12	4	P/N 00924.00 1/4" SS Washer
13	4	P/N 00912.00 1/4" - 20 Nylon Lock Nut
14	16	P/N 00921.00 3/8" - 16 x 3/4" SS Hexhead Bolt
15	2	P/N 13829.00 7/16 - 20 Thin Nylon Lock Nut
16	4	P/N 00238.00 3/8" Male Plug
17	2	P/N 03232.00 1/8" Male Plug
18	2	P/N 00213.00 1" Ford Adapter MIP x PJ Tube
19	2	P/N 00225.00 1" Compression Gasket
20	1	P/N 00704.85 1" 90° Elbow *
21	2	P/N 00200.85 Motor Assy. 1 HP, 3 PH, 220V, 60 HZ **

* For M-2 R → L only.

** Includes Items 1, 2, 3, 4, 5 and 14.



CONTROL BOX ASSEMBLY

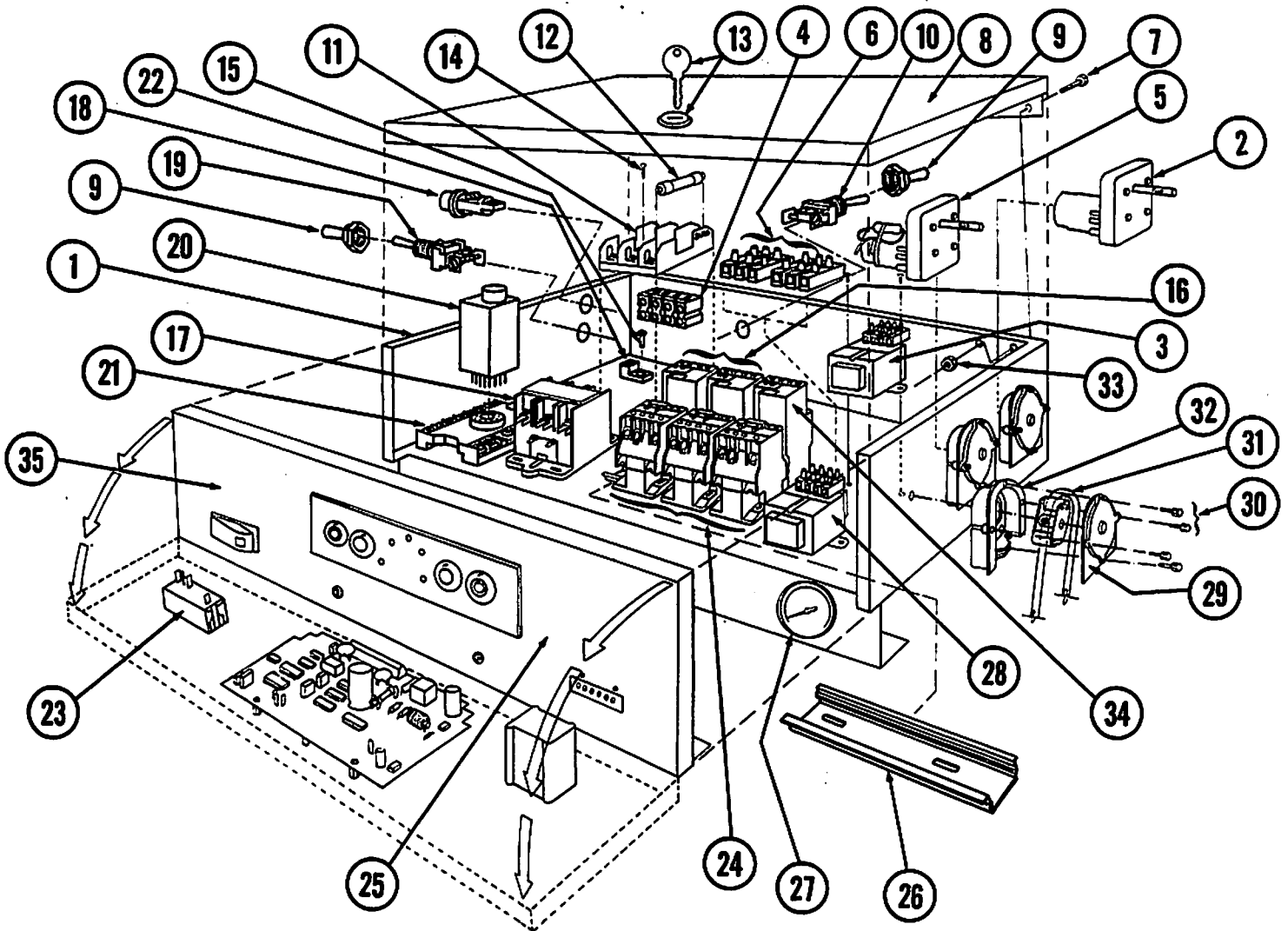

ITEM NO.	NO. REQ'D	DESCRIPTION
1	1	P/N 13890.10, Nova Control Box Only
2	2	P/N 00416.85, Peri-Pump Motor (Nova)
3	1	P/N 00416.95, Rinse Power Transformer
4	1	P/N 13404.20, Terminal Block 4 Position
5	1	P/N 00416.86, Peri-Pump Motor Det (Nova)
6	2	P/N 00454.10, Terminal Block 3 Position
7	2	P/N 00940.50, 10 - 32 x 3/8" Pan Head Screw
8	1	P/N 13890.20, Nova Control Box Lid
9	2	P/N 00470.10, Toggle Switch Rubber Booth
10	1	P/N 13003.70, Timer Relay Override Switch
11	1	P/N 13420.85, Fuse Block 3 Pole
12	3	P/N 13403.83, Fuse 30 Amp Low Peak
13	1	P/N 00449.00, Lock & Key
14	2	P/N 00911.50, 8 - 32 x 3/8" Pan Head Screw
15	2	P/N 00911.00, 8 - 32 x 1/2" Pan Head Screw
16	2	P/N 13012.20, 1 HP Overload Relay
17	1	P/N 13003.40, Heater Contactor (SQD)
18	1	P/N 00406.00, Control Box Light

ITEM NO.	NO. REQ'D	DESCRIPTION
19	1	P/N 00471.10, On-Off Switch
20	1	P/N 13418.85, 60 Sec. Timer Relay
21	1	P/N 13419.85, Timer Power Block Socket
22	2	P/N 13426.50, Control Box Ground Block
23	1	P/N 00421.85, Htr. Rocker Switch Amber
24	3	P/N 13012.10, Motor Starter (SQD)
25	1	P/N 00415.65, Chem. Dispenser Circuit Board
26	1	P/N 13003.60, Starter DIN Rail
27	1	P/N 03202.00, Thermometer
28	1	P/N 00416.96, Initial Power Transformer
29	3	P/N 00418.85, Peri-Pump Cover (Nova)
30	12	P/N 00418.86, Peri-Pump Thumbscrew (Nova)
31	3	P/N 00435.85, Peri-Pump Squeeze Tube (Nova)
32	3	P/N 00417.85, Peri-Pump Block (Nova)
33	2	P/N 03801.00, 10 - 32 Nylon Lock Nut
34	1	P/N 13012.30, 1/3 HP Overload Relay (SQD)
35	1	P/N 13890.30, Nova Control Box Face Panel

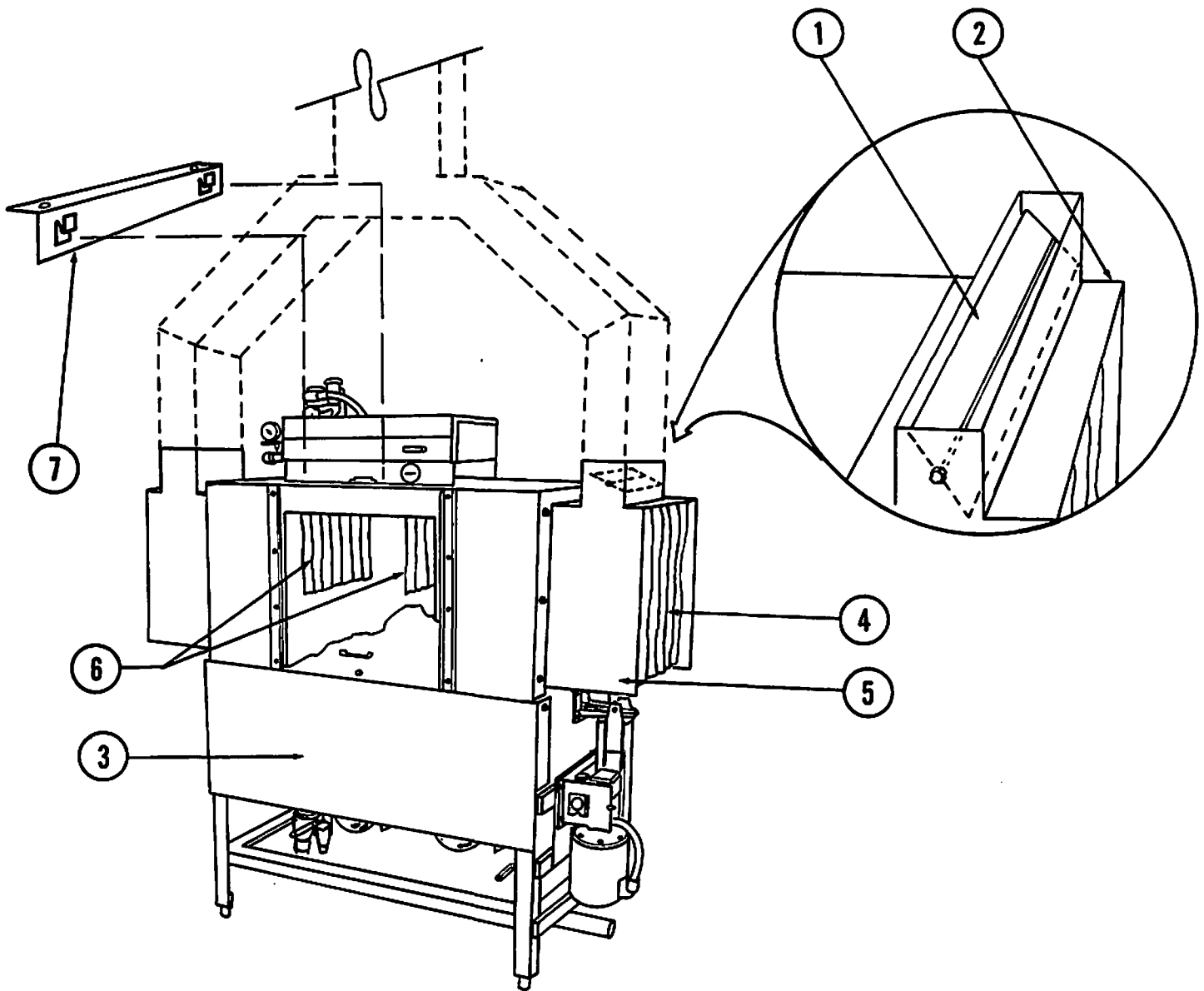

ITEM NO.	NO. REQ'D	DESCRIPTION
1	2	P/N 13901.72 Vent Damper *
2	2	P/N 13901.82 Wrapper Shield w/Vent *
3	1	P/N 13912.82 M-2 Splash Shield
4	2	P/N 13703.20 M-2 Curtain Longest 20-1/2"x19"
5	1	P/N 13702.25 M-2 Curtain Smallest 20-1/2"x15"
6	2	P/N 13702.30 M-2 Curtain (Widest) 24-1/2"x15"
7	2	P/N 13704.50 Conveyor Curtain Splash Guard

* *Optional.*



PADDLE SWITCH ASSEMBLY

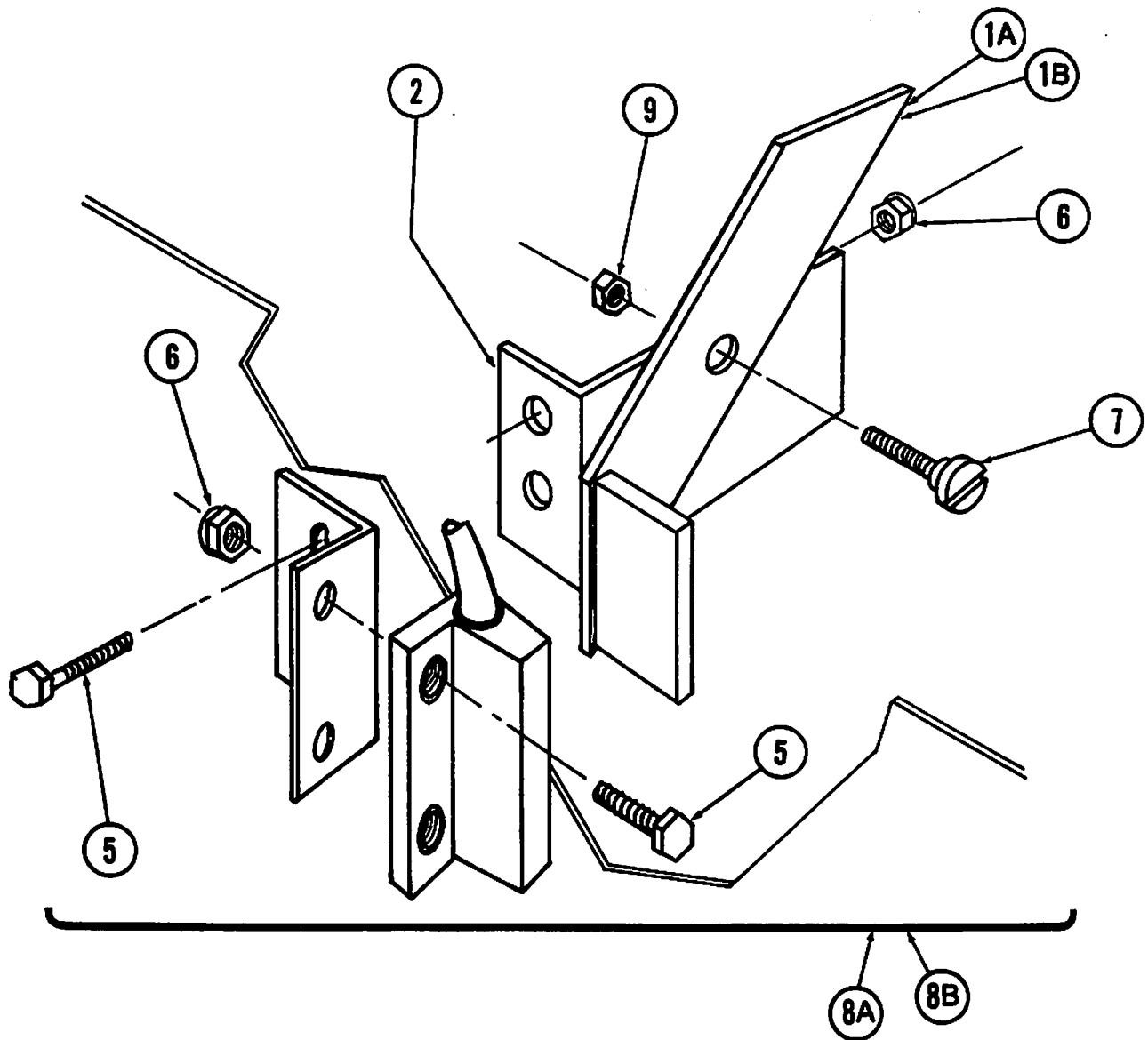

ITEM NO.	NO. REQ'D	DESCRIPTION
1	1-A	P/N 13409.86 Paddle with Magnet, R → L
1	1-B	P/N 13409.89 Paddle with Magnet, L → R
2	1	P/N 13409.87 Paddle Support Bracket
3	1	P/N 00558.50 Reed Switch for Paddle Switch
4	1	P/N 13409.30 P. S. - Reed Switch Bracket
5	4	P/N 00914.00 1/4" - 20 x 3/4" Hexhead Bolt
6	4	P/N 00912.00 1/4" - 20 Nylon Lock Nut
7	1	P/N 00109.00 Shoulder Bolt
8-A	1	P/N 13409.85 Paddle Switch Assembly, R → L
8-B	1	P/N 13409.84 Paddle Switch Assembly, L → R
9	1	P/N 3801.00 10 - 32 Lock Nut