



MODEL UC65e M3

PARTS MANUAL

Rev 1.01 11-15-2024



CMA DISHMACHINES

**17707 VALLEY VIEW AVENUE
CERRITOS, CALIFORNIA 90703**

800-854-6417

FAX 714-895-2141

www.cmadishmachines.com

[Buy Parts](#)

TABLE OF CONTENTS

MODEL CMA UC65e M3

PARTS MANUAL

<u>Illustrations</u>	<u>Page</u>
Wash Pump/Motor Assembly	3
Booster	4
Control Panel	5
Power Wiring Box	6
Fill Valve	7, 8 & 9
Wash and Rinse Spray Arms	10
Hoses and Drain Pump	11
Panels and Door	12
Upper Tank	13
Rear Tank	14
Chemical Pumps	15
Rinse-aid Dispensing Pump	16
Detergent Dispensing Pump	17
Dish racks and Pressure Regulating Valve (PRV)	18
Optional Chemical Alarm	19

Pump and Motor

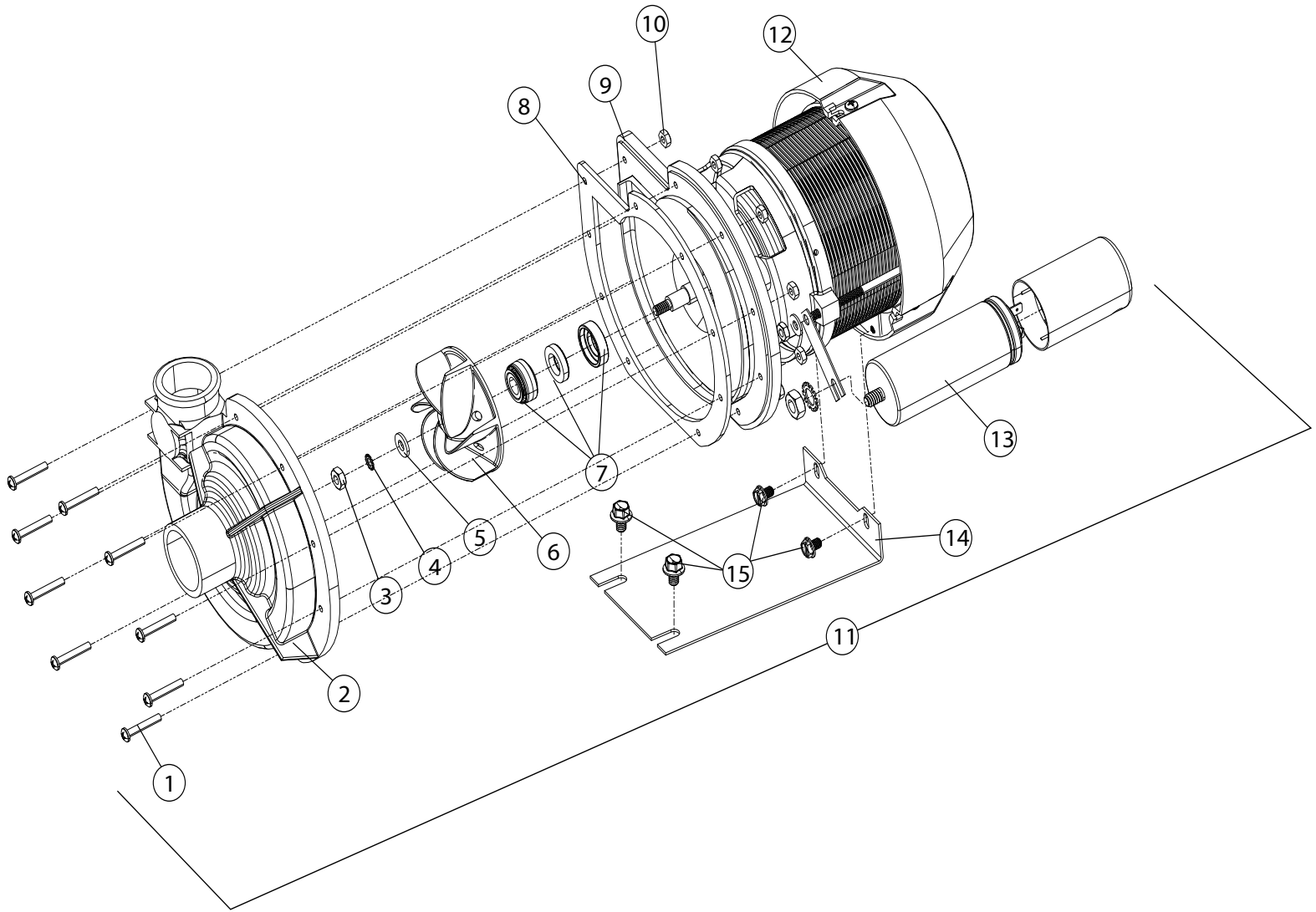

ITEM NO.	NO. REQ'D	P/N	DESCRIPTION
1	9	02103.01	Screw, M4, Phil, Pan Head
2	1	02103.02	Impeller Housing Cover
3	1	02107.01	Nut, M6 (Left-hand thread)
4	1	02103.04	1/4" Lock Washer
5	1	02103.05	17/64" Plain Washer
6	1	02107.02	Impeller
7	1	02103.07	Pump Seal
8	1	02103.30	Pump Gasket
9	1	02107.03	Pump Backing Plate

ITEM NO.	NO. REQ'D	P/N	DESCRIPTION
10	9	02103.08	Nut, M4
11	1	02103.10	Pump Motor Assm, 220V
12	1	02103.37	Motor Fan Cover
13	1	02103.11	Capacitor, 16 μ F
14	1	02107.04	Wash Pump Bracket
15	2	02107.05	Bolt, Hex Flange 1/4-20 X 3/8" SST
***		02103.10	Motor unavailable as separate part

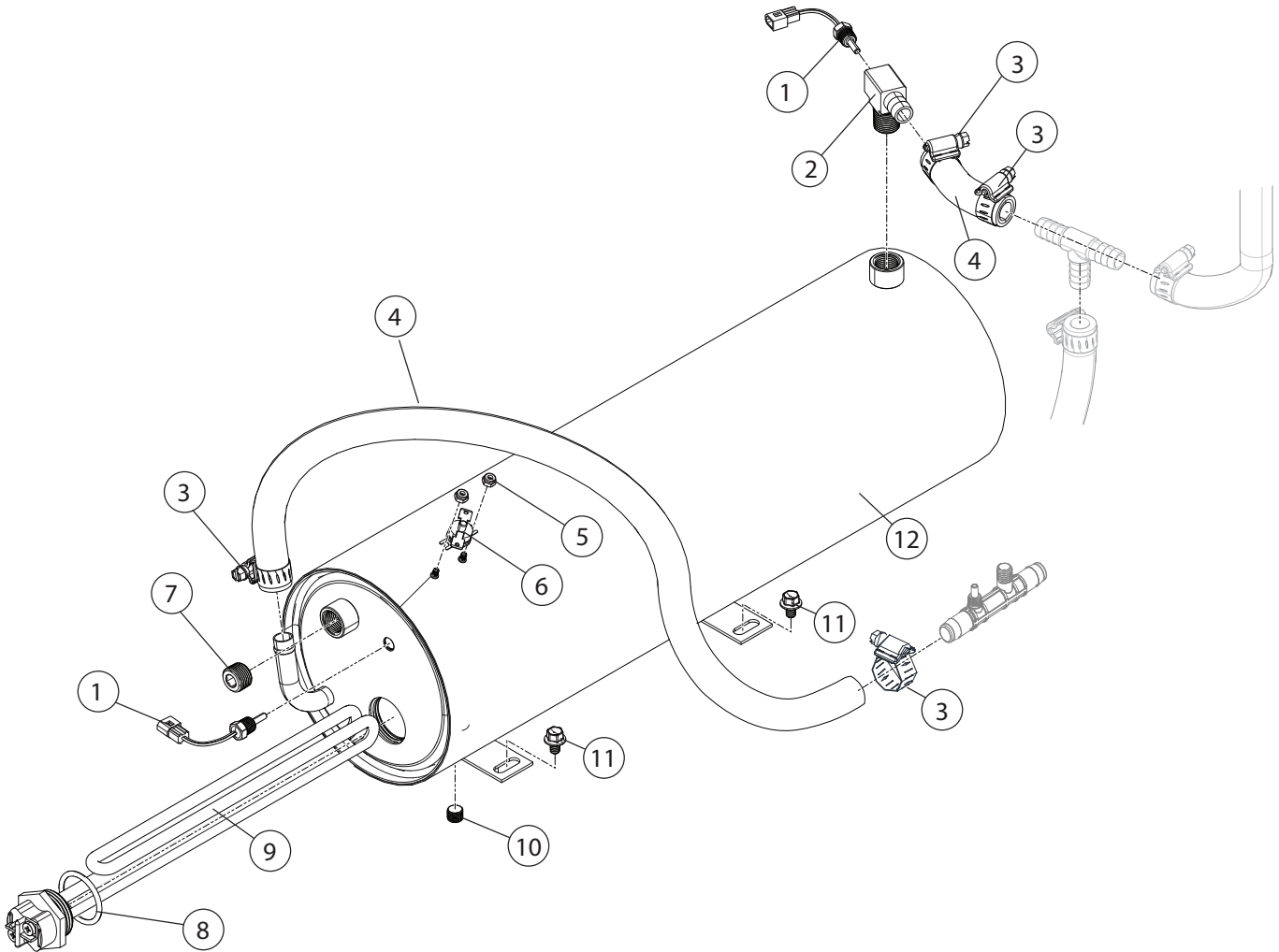

ITEM NO.	NO. REQ'D	P/N	DESCRIPTION
1	1	02107.0L	Thermistor
2	1	02107.11	Tee, Rinse
3	4	02103.21	Clamp, Hose
4	A/R	03107.50	Hose, Rubber 1/2"x0.84" OD
5	2	00965.00	Nut, Grip 6-32 W/ Nylon Insert SS
6	1	02103.19	Thermostat, High Limit 240f

ITEM NO.	NO. REQ'D	P/N	DESCRIPTION
7	1	03232.00	Plug, 1/8"
8	1	02103.14	Gasket
9	1	02103.12	4kW 208V 40Rise Element ***
10	1	02107.09	Plug, 1/8 Hex Countersunk SS
11	2	02103.16	Bolt, Hex Flange, 1/4-20x3/8" SS
12	1	02106.01	Booster Tank, Welded

*** 6kW 208V 70Rise Element Optional PN02103.13

Control Panel

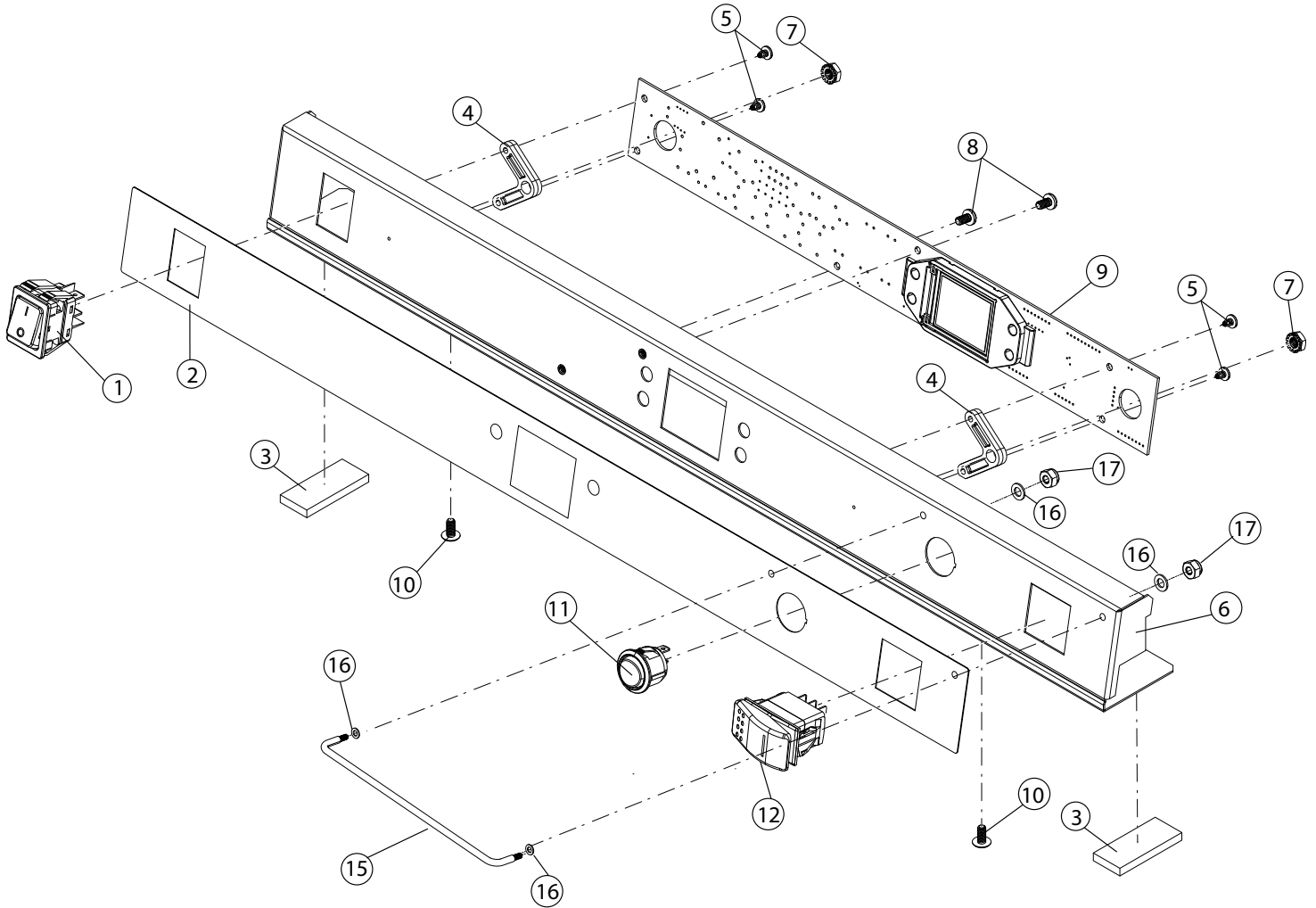

ITEM NO.	NO. REQ'D	P/N	DESCRIPTION
1	1	02107.15	Switch, Rocker DPST 250V Neon
2	1	02106.51	Label, Facia UC65e M3
3	2	02103.58	Gasket, Steam
4	2	02107.17	Standoff, LED Display Board
5	4	02104.91	Screw, 6-18x1/4" Panhead Phil SS
6	1	02106.52	Panel, Facia UC65e M3
7	2	02104.68	Nut, 10-32
8	2	02107.20	Screw, #8 x 3/8"
9	1	02107.21	Kit, Control Board
10	1	00911.10	Screw, 8-32x3/8 Truss HD

ITEM NO.	NO. REQ'D	P/N	DESCRIPTION
11	1	02103.57	Prime Switch
12	1	15523.00	Contact, Switch Momentary (N.O.)
13	1	02103.52	Housing, Push Button Switch
14	1	02103.53	Push Button, Green
15	1	03485.00	Switch Guard
16	4	04086.00	#10 Washer
17	2	03801.00	10-32 Lock Nut
---	1	02107.22	Harness, Start & Door - NOT SHOWN
---	1	02106.83	Harness, Sensor - NOT SHOWN
---	1	02106.87	Harness, Main - NOT SHOWN
---	1	02107.24	Jumper Wire - NOT SHOWN

Fuses, Not Shown; 1/16A PN02107.89; 4A PN02107.90

Power Wiring Box

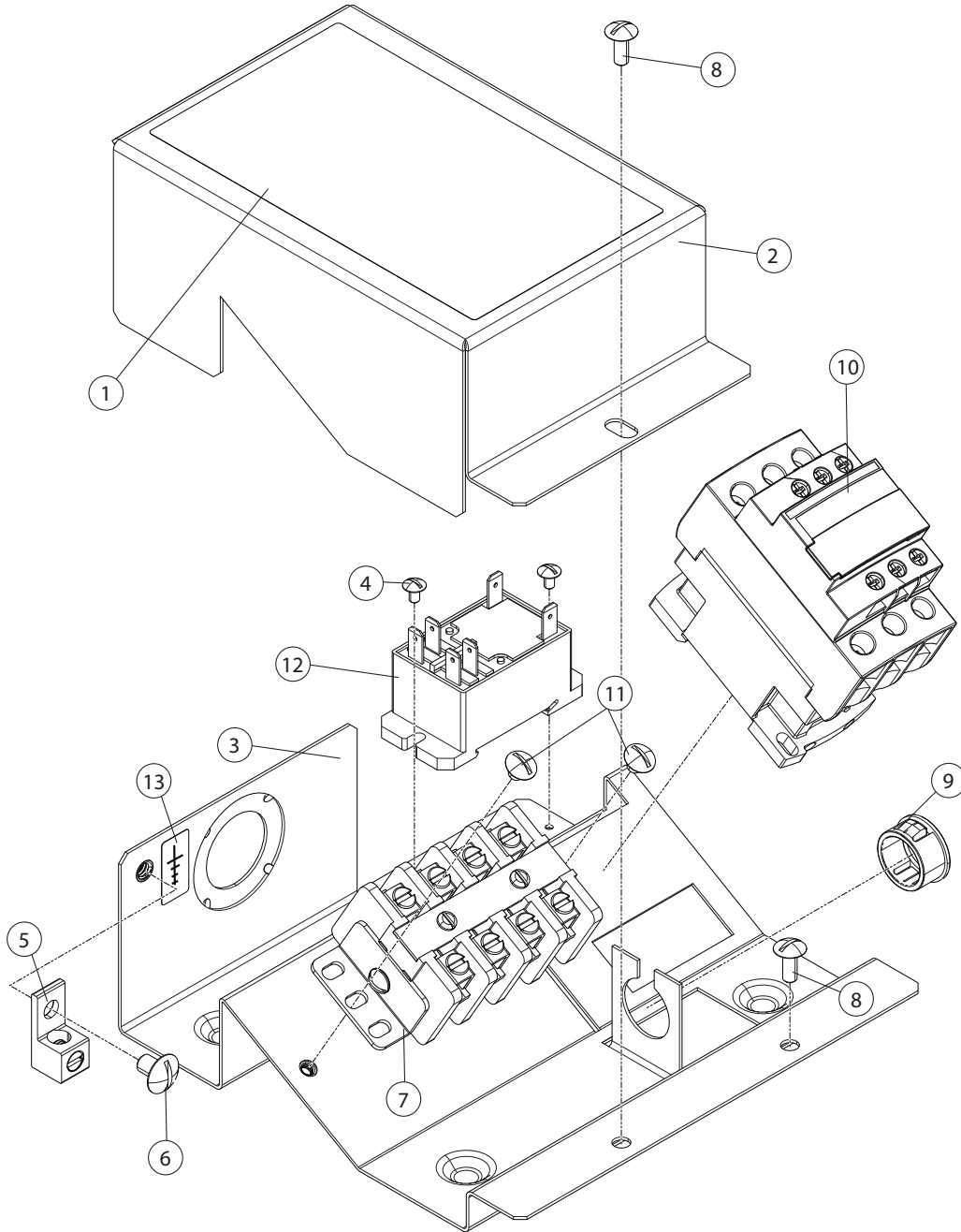

ITEM NO.	NO. REQ'D	P/N	DESCRIPTION
1	1	02106.02	Label, Connection Box
2	1	02106.03	Cover, Box Wiring
3	1	02106.04	Box, Wiring
4	2	00421.51	Screw, 6-32 X 1/4"
5	1	13426.50	Lug, Ground
6	1	00905.82	Screw, 1/4-20 X 3/8"
7	1	02106.05	Block, Terminal 4-Pole

ITEM NO.	NO. REQ'D	P/N	DESCRIPTION
8	2	00940.50	Screw, 10-32 X 3/8" Truss Head
9	1	02106.15	Bushing, Strain Relief, Small
10	1	02103.48	Contact, 3-Pole, 25/40A, 120VAC Coil
11	2	00940.00	Screw, 10-32 X 1/4"
12	1	02106.06	Relay, DPDT, 30A, 120VAC Coil
13	1	06202.46	Label, Ground

**Fill Solenoid Valve - Effective June 2024
Beginning W2406119475**

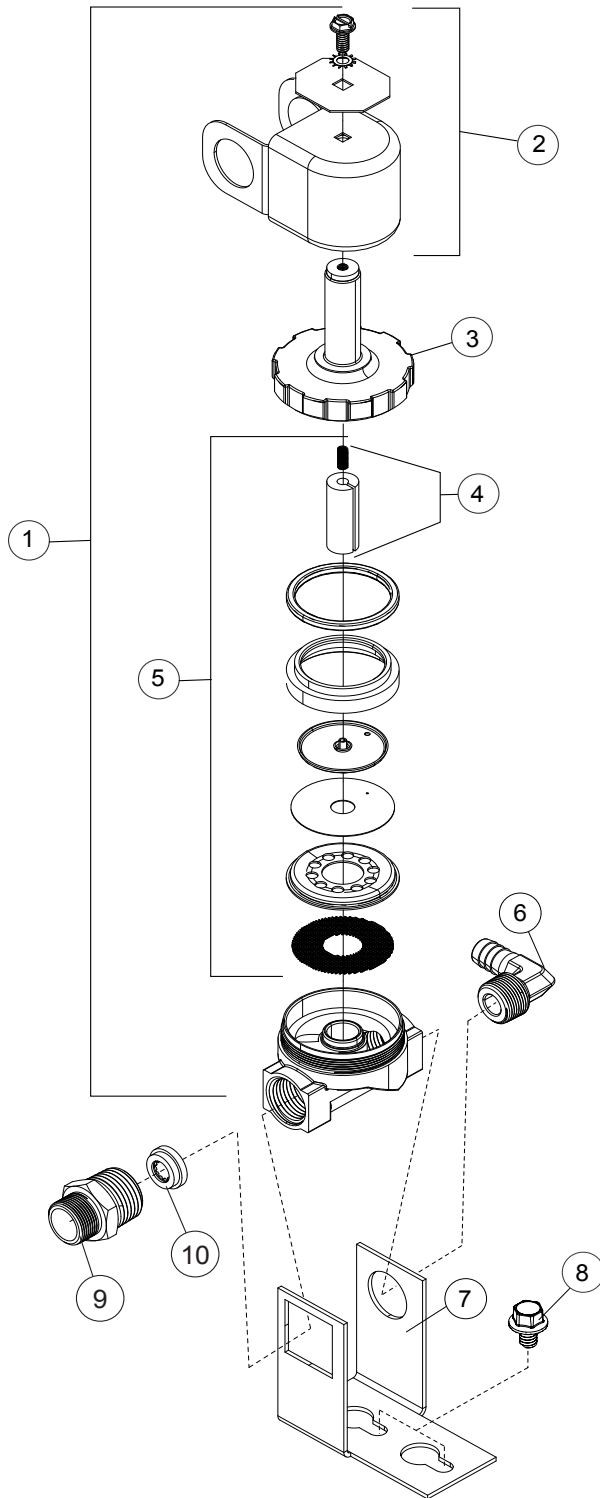

ITEM NO.	NO. REQ'D	P/N	DESCRIPTION
1	1	00705.00	Water Valve 3/4" 115V JE Complete
2	1	00738.10	Solenoid Coil, 115VAC
3	1	00705.20	3/4" Water Solenoid Bonnet
4	1	00786.00	JE Water Valve Plunger & Spring
5	1	00706.00	3/4" Water Solenoid Valve Repair Kit
6	1	40013.00	Fitting, Barb Hose
7	1	02107.91	Bracket, 3/4" Valve, UC65e
8	2	02103.16	Bolt, Hex Flange 1/4-20x3/8"
9	1	03604.50	Fitting, Flow Disc
10	1	03604.10	Washer, Flow Disc
--	2	00741.00	3/4 X 1/2 Bushing - NOT SHOWN

[13602.28](#) 1/2" Pressure Regulator, OPTIONAL

Fill Solenoid Valve - Effective October 2022

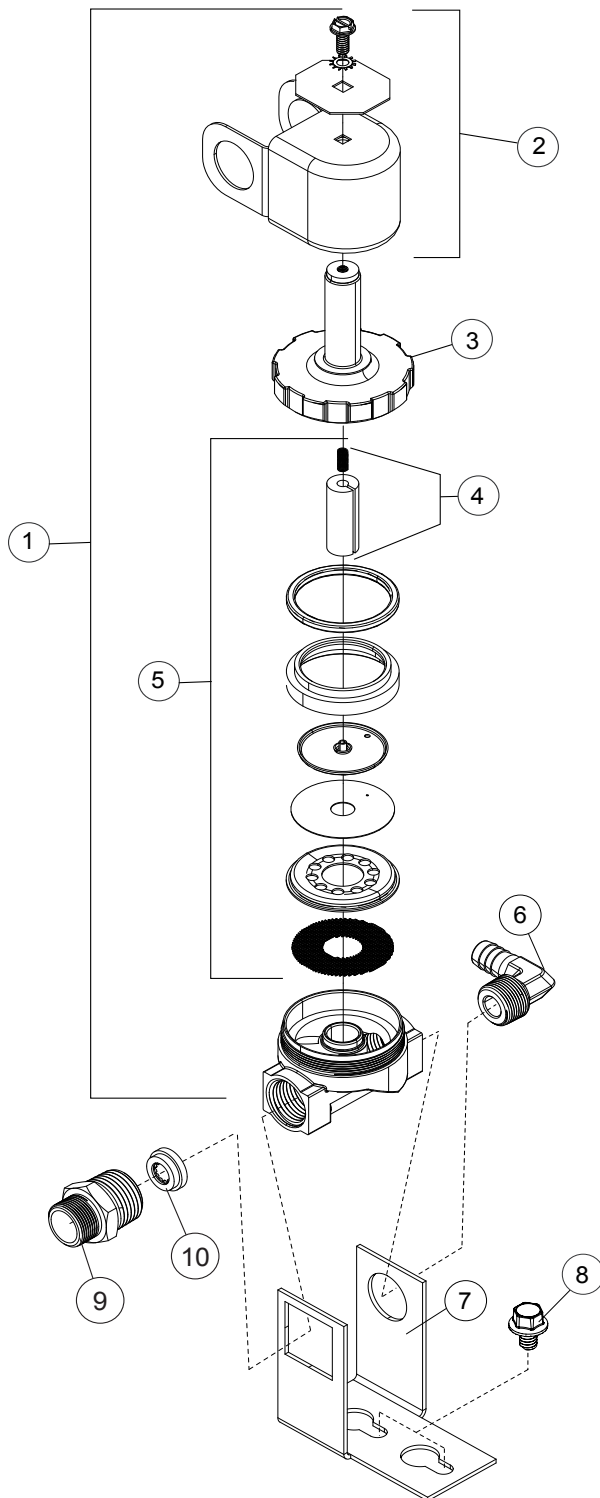

ITEM NO.	NO. REQ'D	P/N	DESCRIPTION
1	1	03603.10	Water Valve 1/2" 115V JE Complete
2	1	00738.10	Solenoid Coil, 115VAC
3	1	03603.20	1/2" Water Solenoid Bonnet
4	1	00786.00	JE Water Valve Plunger & Spring
5	1	00707.00	1/2" Water Solenoid Valve Repair Kit
6	1	40013.00	Fitting, Barb Hose
7	1	02106.11	Bracket, Valve, UC65e
8	2	02103.16	Bolt, Hex Flange 1/4-20x3/8"
9	1	03604.50	Fitting, Flow Disc
10	1	03604.10	Washer, Flow Disc

Fill Valve

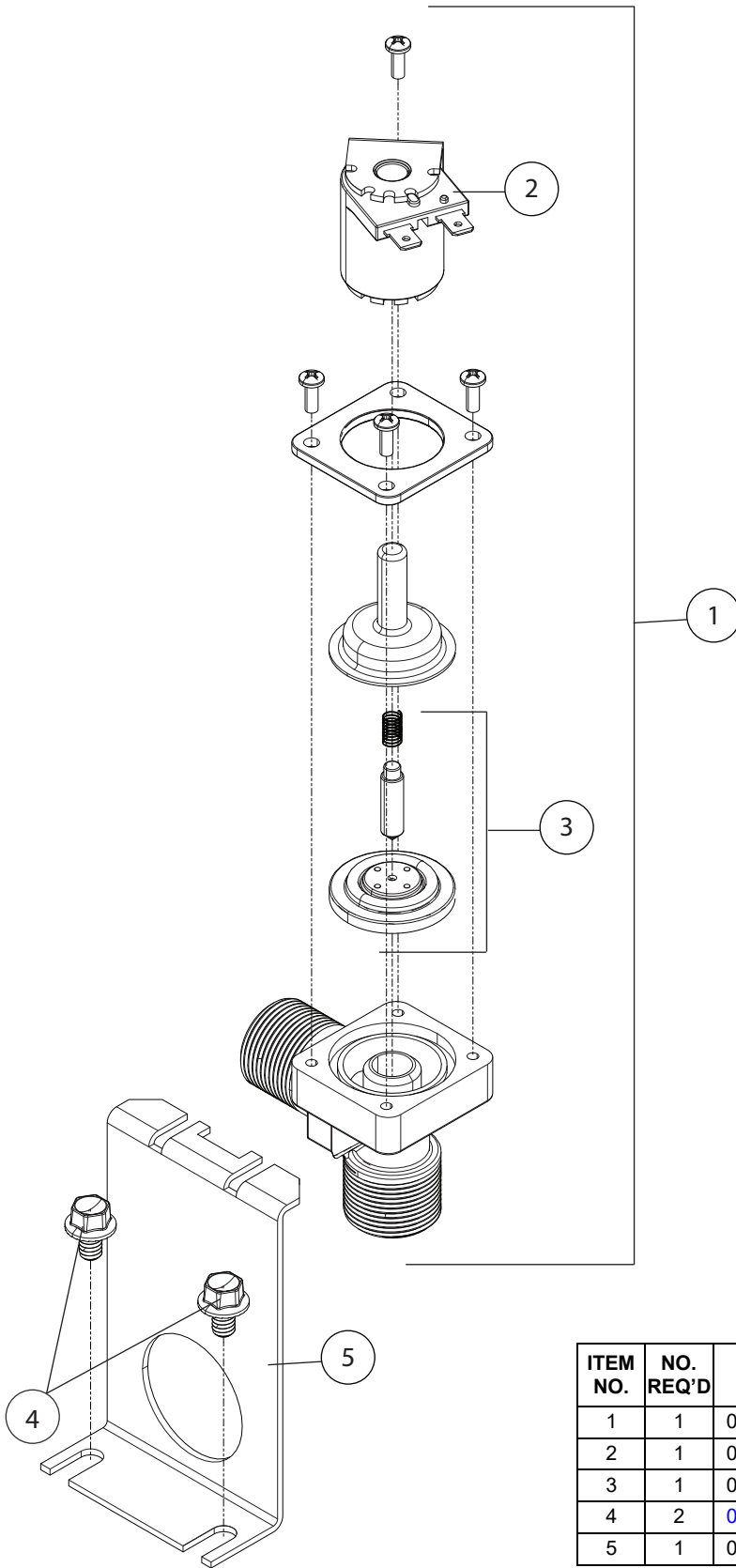

ITEM NO.	NO. REQ'D	P/N	DESCRIPTION
1	1	02106.53	Water Valve 115V, Incl Items 2 & 3
2	1	02106.54	Coil, 115VAC/60/1, 7W
3	1	02106.55	Solenoid Repair Kit
4	2	00906.52	Bolt, Hex Flange, 1/4-20X3/8" SS
5	1	02106.56	Bracket, Fill Valve

Wash and Rinse Spray Assemblies

ITEM NO.	NO. REQ'D	P/N	DESCRIPTION
1	4	00426.00	Washer, 5/16" SS
2	4	00912.00	Nut, 1/4-20 Nylon Lock
3	1	02103.77	Hub, Upper Wash Arm
4	1	02103.78	Washer, Packing
5	1	02103.79	Screw, Retaining
6	1	02103.83	O-Ring, 2-1/8" OD X 1-3/4" ID X 3/16"
7	2	02103.82	Bearing Assembly
8	2	02103.98	Spacer, Nut
9	1	02103.83	O-Ring, 2-1/8" OD X 1-3/4" ID X 3/16"
10	1	02103.84	Hub, Lower Wash Arm
11	1	02103.85	Manifold, Lower FWR
12	2	02103.86	Wash Arm Assm, (Incl Item #7)
14	4	02103.88	Washer, Nylite
15	4	00962.00	Bolt, 1/4-20 X 1"
16	1	02103.90	Shaft, Lower
17	1	02103.91	O-Ring
18	2	02103.92	Hub, Rinse Arm Molded
19	4	02103.93	Screw, Truss Head 8-32 X 1/4"
20	2	02103.94	Arm, Right-Hand Rinse (7 Jets)
21	2	02103.95	Arm, Left-Handed Rinse (8 Jets)
22	4	02103.96	Cap, Rinse Arm, 5/16-24
23	4	02103.97	Spindle, Rinse Arm
---	-	02103.99	Rinse Arm Assm (Incl Items 8, 18-23)

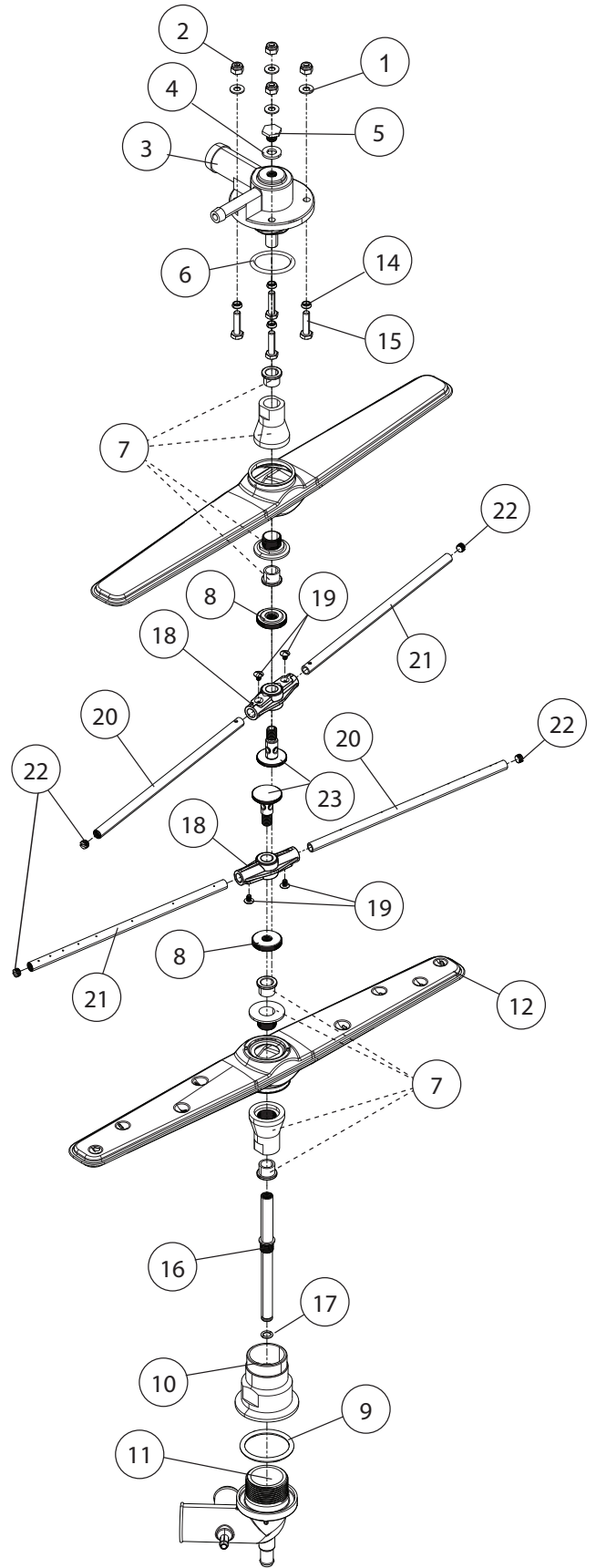

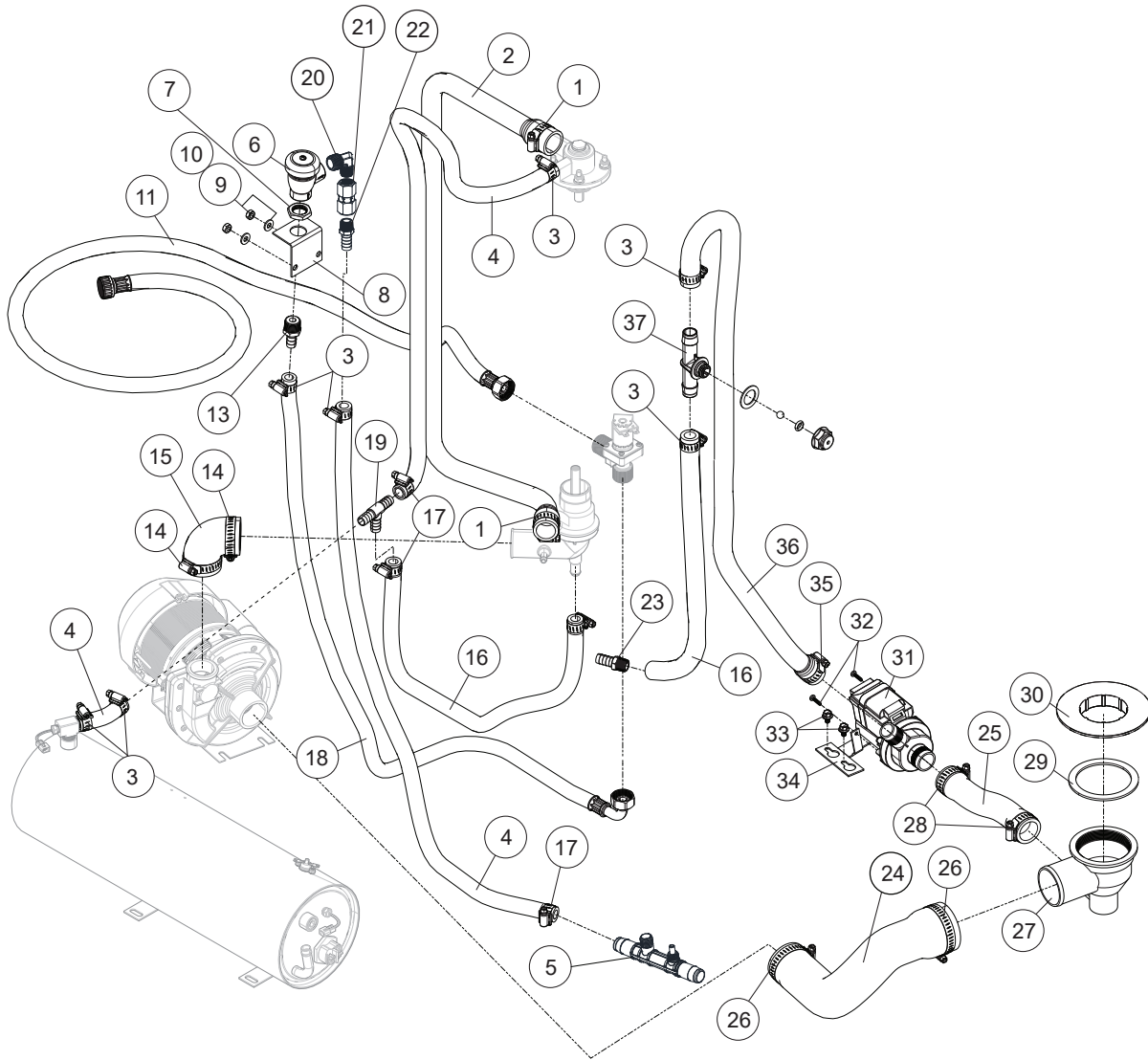

ITEM NO.	NO. REQ'D	P/N	DESCRIPTION
1	2	50109.00	Clamp, Hose
2	1	02103.81	Hose, Upper Wash Arm
3	8	02103.21	Clamp, Hose Gear-type SS
4	A/R	03107.50	Hose, Rubber 1/2" ID X 0.84" OD
5	1	02106.57	Fitting, Molded Rinse
6	1	02103.71	1/2" Vacuum Breaker
--	--	02103.72	Vacuum Breaker Repair Kit
7	1	00721.00	Lock Nut, 1/2"
8	1	02103.69	Bracket, Vacuum Breaker
9	2	02103.04	Washer, Split 1/4" SS
10	2	00923.50	Nut, Hex 1/4-20 SS
11	1	N/A	Hose, Fill
13	2	02106.58	Barb, Hose 1/2" X 3/8" MPT
14	2	50109.00	Clamp, Hose
15	1	02104.13	Hose, Discharge
16	A/R	02107.71	Hose, 5/8" ID X 1" OD
17	2	03101.00	Clamp, Hose
18	1	02103.18	Hose, Booster Fill
19	1	02106.59	Tee, 3/4" Poly
20	1	02106.60	Elbow, 1/2MPTx3/8MPT Reduce 90DE

ITEM NO.	NO. REQ'D	P/N	DESCRIPTION
21	1	02106.61	Valve, Check 3/8
22	1	02106.62	Hose Barb, 1/2 x 3/8 MPT
23	1	02106.63	Coupler, 3/4"MPT x 3/4" Hose Barb
24	1	02104.11	Hose, Suction Wash Pump
25	1	02104.05	Hose, Drain Pump Suction
26	2	02104.10	Clamp, Hose
27	1	02104.34	Elbow, Pump Suction
28	2	03101.00	Clamp, Hose Gear-Type
29	1	02104.35	Gasket, Pump Suction
30	1	02104.36	Flange, Pump Suction
31	1	02104.07	Pump, Drain
32	2	02107.74	Screw, #8 x 1/2" Self-Taping
33	2	02103.16	Bolt, Hex Flange 1/4-20 x 3/8" SS
34	1	02104.06	Bracket, Drain Pump
35	1	03101.00	Clamp, Hose
36	1	02106.19	Hose, Drain Molded
37	1	02106.50	Anti-Siphon Assembly Complete

Panels and Door

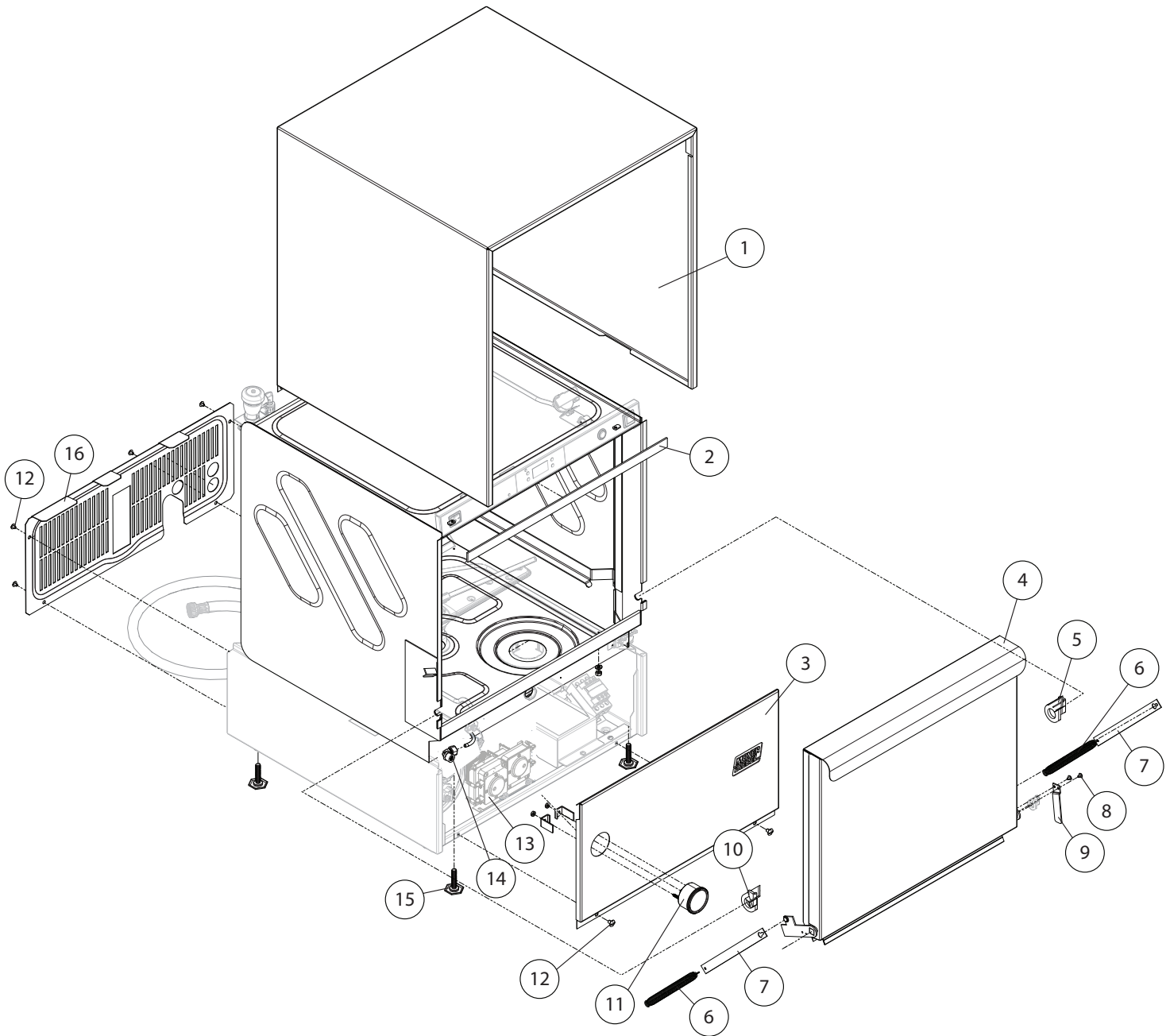

ITEM NO.	NO. REQ'D	P/N	DESCRIPTION
1	1	02104.69	Wrapper, Outer Panel
2	1	02104.17	Gasket, Door 1/8" x 7/8" x 22-5/8"
3	1	02106.64	Panel, Front
4	1	02104.73	Door Welded Assm
5	1	02104.88	Seal, Door Hinge RH
6	2	02104.77	Spring, Door
7	2	02104.76	Arm, Door Spring
8	1	02106.65	Screw, 8-32 x 3/16" Phil SS

ITEM NO.	NO. REQ'D	P/N	DESCRIPTION
9	1	02104.78	Activator, Door Switch
10	1	02104.87	Seal, Door Hinge LH
11	1	02104.63	Gauge, Pressure 0-60PSI
12	1	00940.50	Screw, 10-32x3/8" Truss Head Phil SS
13	1	00425.54	Tubing, 1/4" Natural
14	1	02106.66	Adaptor, 1/4"x1/8"NPT Female Plastic
15	1	02104.67	Foot, Adjusting
16	1	02106.13	Panel, Rear

Upper Tank

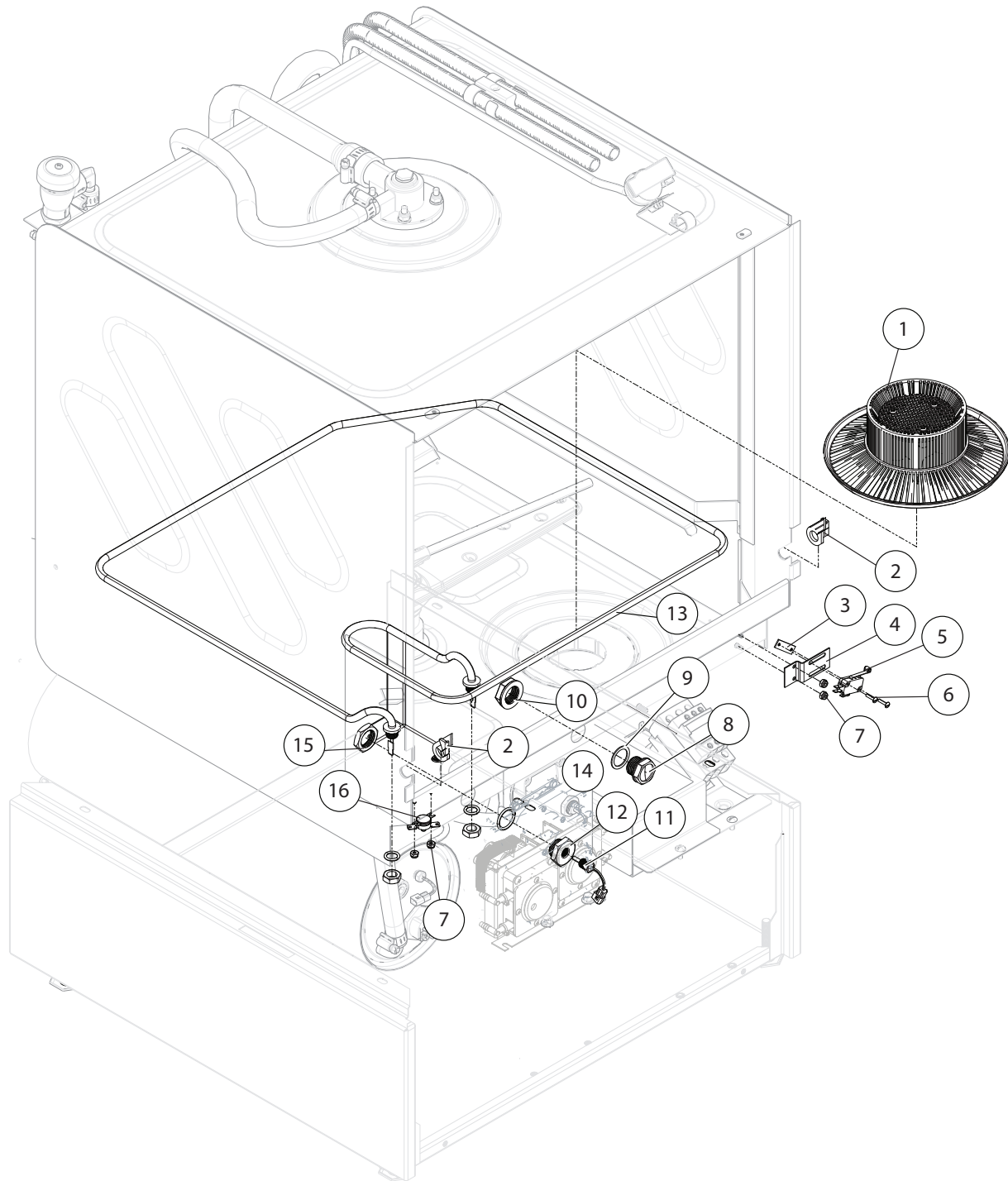

ITEM NO.	NO. REQ'D	P/N	DESCRIPTION
1	1	02106.67	Screen, Scrap
2	1	See Pg10	Seal, Door Hinge RH & LH
3	1	02106.68	Plate, Nut 4-40
4	1	02106.69	Bracket, Switch Door
5	1	43019.00	Switch, Door 15A
6	2	13826.00	Screw, 4-40x1/2" Pan Head Phil SS
7	2	00965.00	Nut, Grip 6-32 W/ Nylon Insert SS
8	1	02106.70	Plug, 1/2"

ITEM NO.	NO. REQ'D	P/N	DESCRIPTION
9	1	02106.71	Gasket, Fiber
10	1	02106.72	Nut
11	1	02107.0L	Thermister
12	1	02106.73	Adapter, Thermister
13	1	02104.18	Element, Tank 2kW 240VAC
14	1	02106.74	O-Ring
15	1	02106.75	Nut, 1/2" NP
16	1	02104.28	Thermostat, Fixed Snap, 212°F

Tank Rear

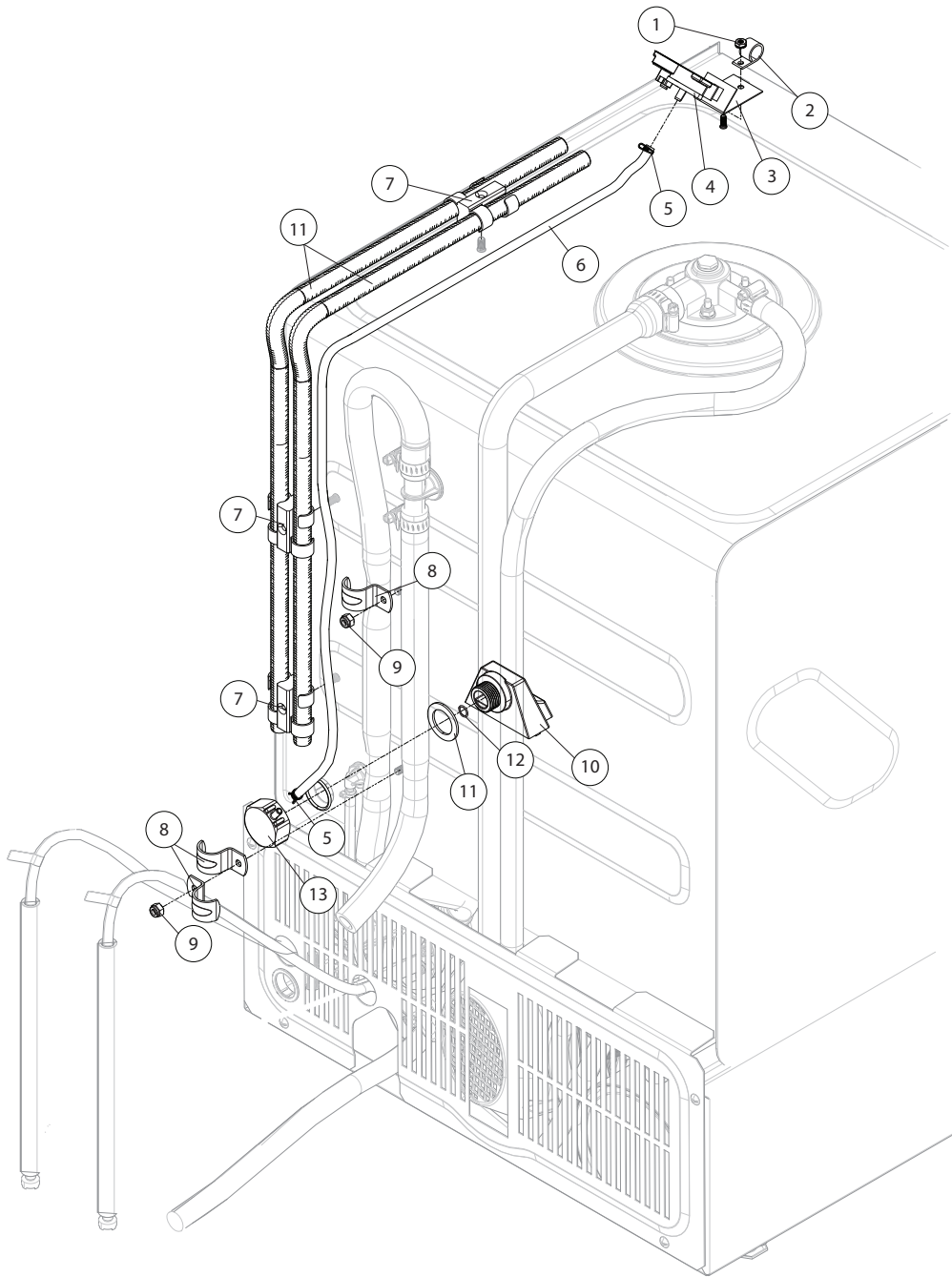

ITEM NO.	NO. REQ'D	P/N	DESCRIPTION
1	1	03801.00	Nut, 10-32 SS
2	1	N/A	Clip
3	1	02106.76	Bracket, Sensor
4	1	02106.77	Sensor, Level
5	1	02104.54	Clamp, Hose
6	2	02104.56	Hose, Air
7	2	N/A	Clamp, Double Conduit

ITEM NO.	NO. REQ'D	P/N	DESCRIPTION
8	1	N/A	Clamp, 3/4" Plated Strap
9	1	02107.48	Nut, Grip, 1/4-20 W/ Nylon Insert SS
10	1	02104.53	Trap, Air
11	1	02104.55	Gasket, Air Trap
12	1	02104.57	O-Ring
13	1	02104.59	Cover, Air Trap

Chemical Pumps

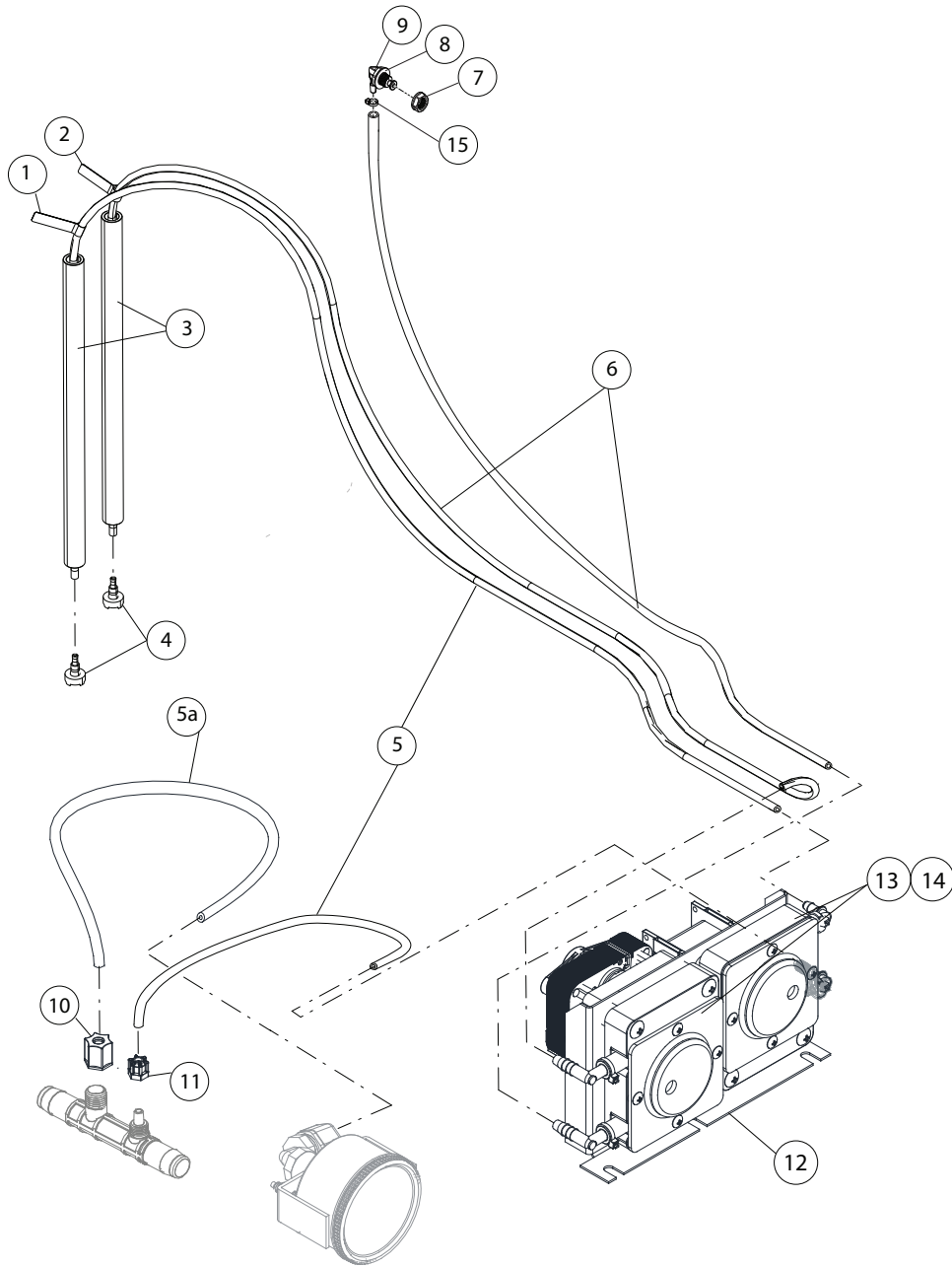

ITEM NO.	NO. REQ'D	P/N	DESCRIPTION
1	1	43078.08	Label, Rinse Additive
2	1	43078.05	Label, Detergent
3	2	02104.48	Tube Stiffener, 1/2" x 11-7/8"
4	1	02104.47	Strainer
5	A/R	02106.78	Hose, 4MM ID x 6MM (1/4") OD PVC
5a	A/R	00425.24	Chemical Tubing, White
6	A/R	02104.37	Hose, 1/4"ID x 3/8"OD PVC
7	1	02106.79	Nut

ITEM NO.	NO. REQ'D	P/N	DESCRIPTION
8	1	02104.39	Gasket
9	1	02106.80	Kit, Detergent Fitting
10	1	02106.81	Nut, Compression Rinse
11	1	02106.82	Nut, Chemical Tube
12	1	02107.14	Bracket, Chemical Pump
13	1	00415.00	Rinse Chemical Pump Assembly
14	1	00415.00	Detergent Chemical Pump Assembly
15	1	00931.00	Nylon Zip Tie, 4"

Detergent Pump

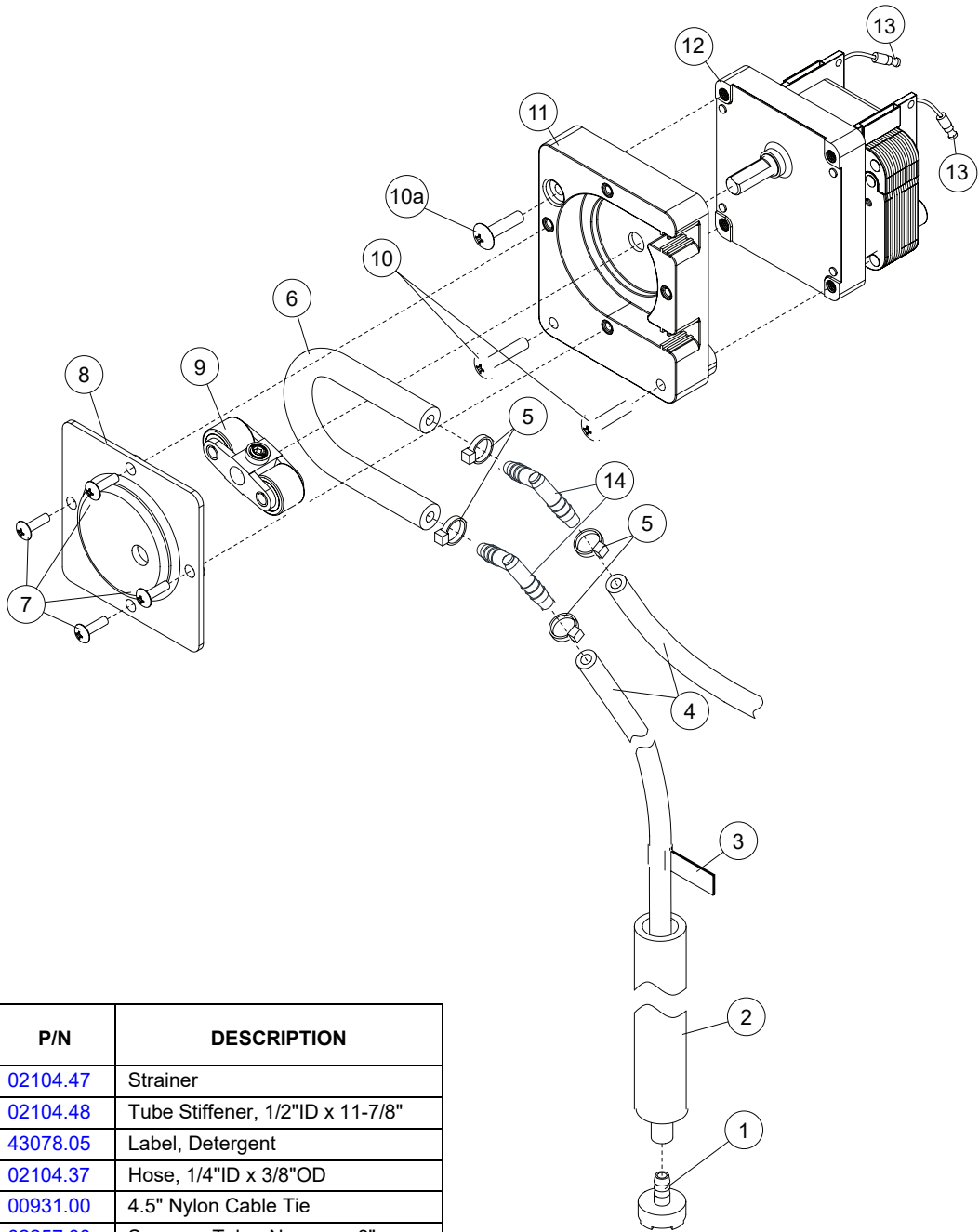

ITEM NO.	NO. REQ'D	P/N	DESCRIPTION
1	2	02104.47	Strainer
2	2	02104.48	Tube Stiffener, 1/2"ID x 11-7/8"
3	1	43078.05	Label, Detergent
4	A/R	02104.37	Hose, 1/4"ID x 3/8"OD
5	4	00931.00	4.5" Nylon Cable Tie
6	1	02257.00	Squeeze Tube, Norprene 8"
7	1	00911.00	Screw, 8-32x1/2" Panhead
8	1	00418.00	Peristaltic Pump Cover
9	1	00419.00	Peristaltic Pump Rotor
10	1	00919.00	Screw, 10-32 x 1-1/2" Panhead
10a	2	00918.10	Screw, 10-32 x 1-1/2" Flathead
11	1	00417.10	Peristaltic Pump Block (Black)
12	1	00416.00	Peristaltic Pump Motor 110V/60Hz
13	1	00448.00	Barrel Connector, Male
14	2	02104.52	1/4" Hose Barb
15	1	00415.20	Peri Pump Assm (Incl items 6-13)

Rinse Pump

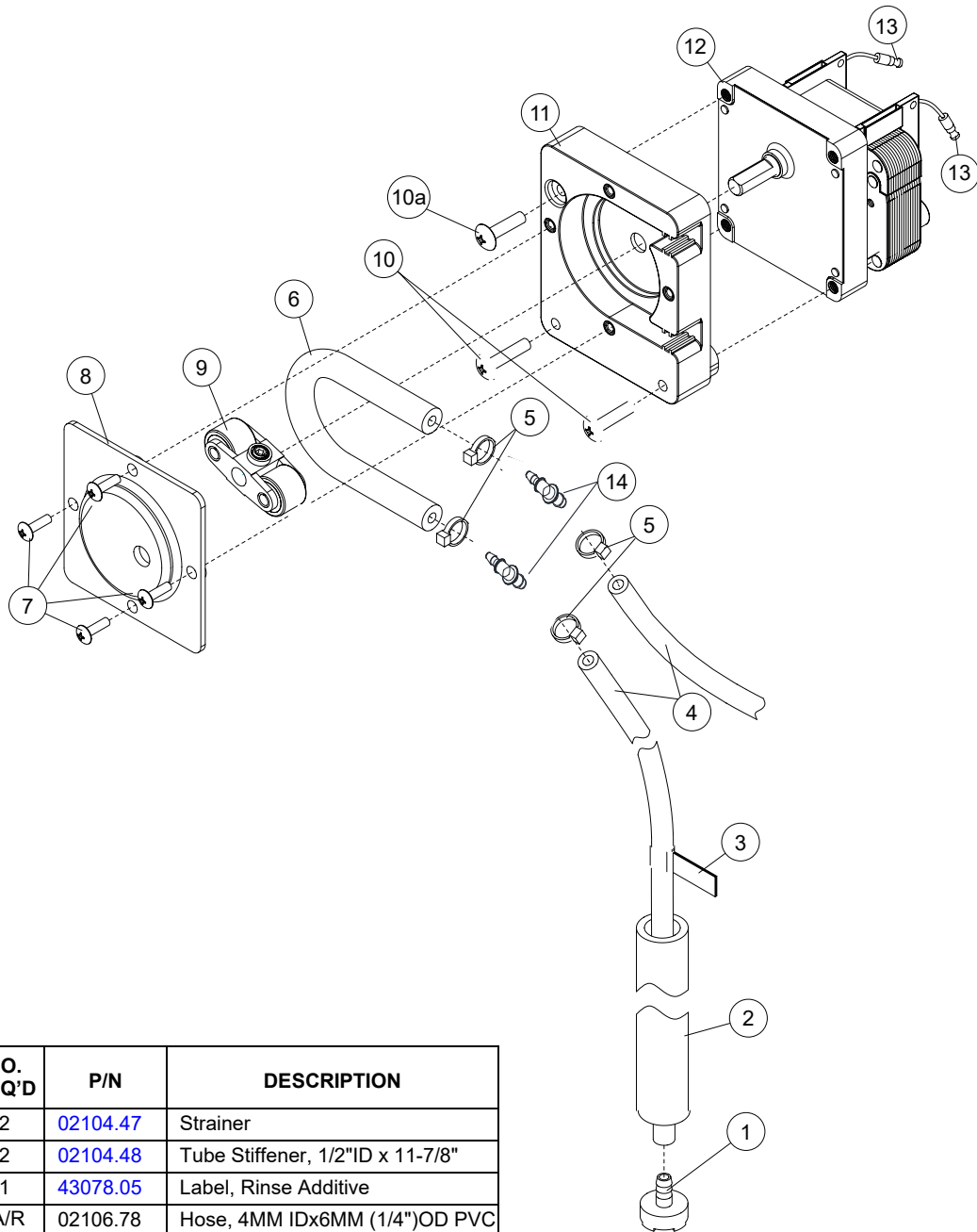

ITEM NO.	NO. REQ'D	P/N	DESCRIPTION
1	2	02104.47	Strainer
2	2	02104.48	Tube Stiffener, 1/2"ID x 11-7/8"
3	1	43078.05	Label, Rinse Additive
4	A/R	02106.78	Hose, 4MM IDx6MM (1/4")OD PVC
5	4	00931.00	4.5" Nylon Cable Tie
6	1	02104.58	Squeeze Tube, Norprene 1/8"
7	1	00911.00	Screw, 8-32x1/2" Panhead
8	1	00418.00	Peristaltic Pump Cover
9	1	00419.00	Peristaltic Pump Rotor
10	1	00919.00	Screw, 10-32 x 1-1/2" Panhead
10a	2	00918.10	Screw, 10-32 x 1-1/2" Flathead
11	1	00417.10	Peristaltic Pump Block (Black)
12	1	00416.00	Peristaltic Pump Motor 110V/60Hz
13	1	00448.00	Barrel Connector, Male
14	2	02106.12	1/8" Hose Barb
15	1	00415.20	Peri Pump Assm (Incl items 6-13)

Dish Racks, PRV

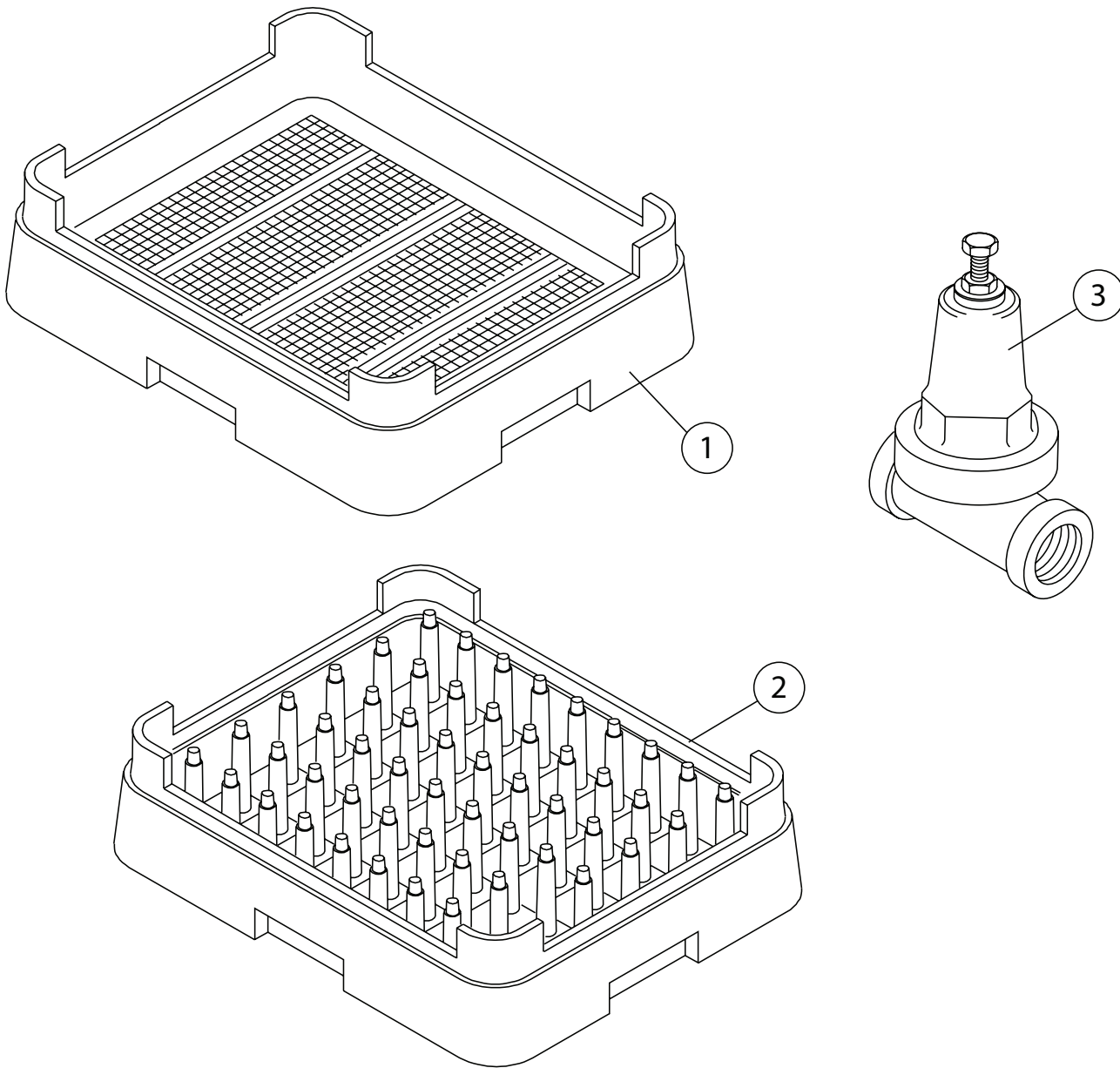

ITEM NO.	NO. REQ'D	P/N	DESCRIPTION
1	1	12960.01	Dish Rack, Flat
2	1	12960.03	Dish Rack, Peg
3	1	13602.28	1/2" Pressure Regulator, OPTIONAL

Optional Chemical Alarm

Part Number **12508.00**

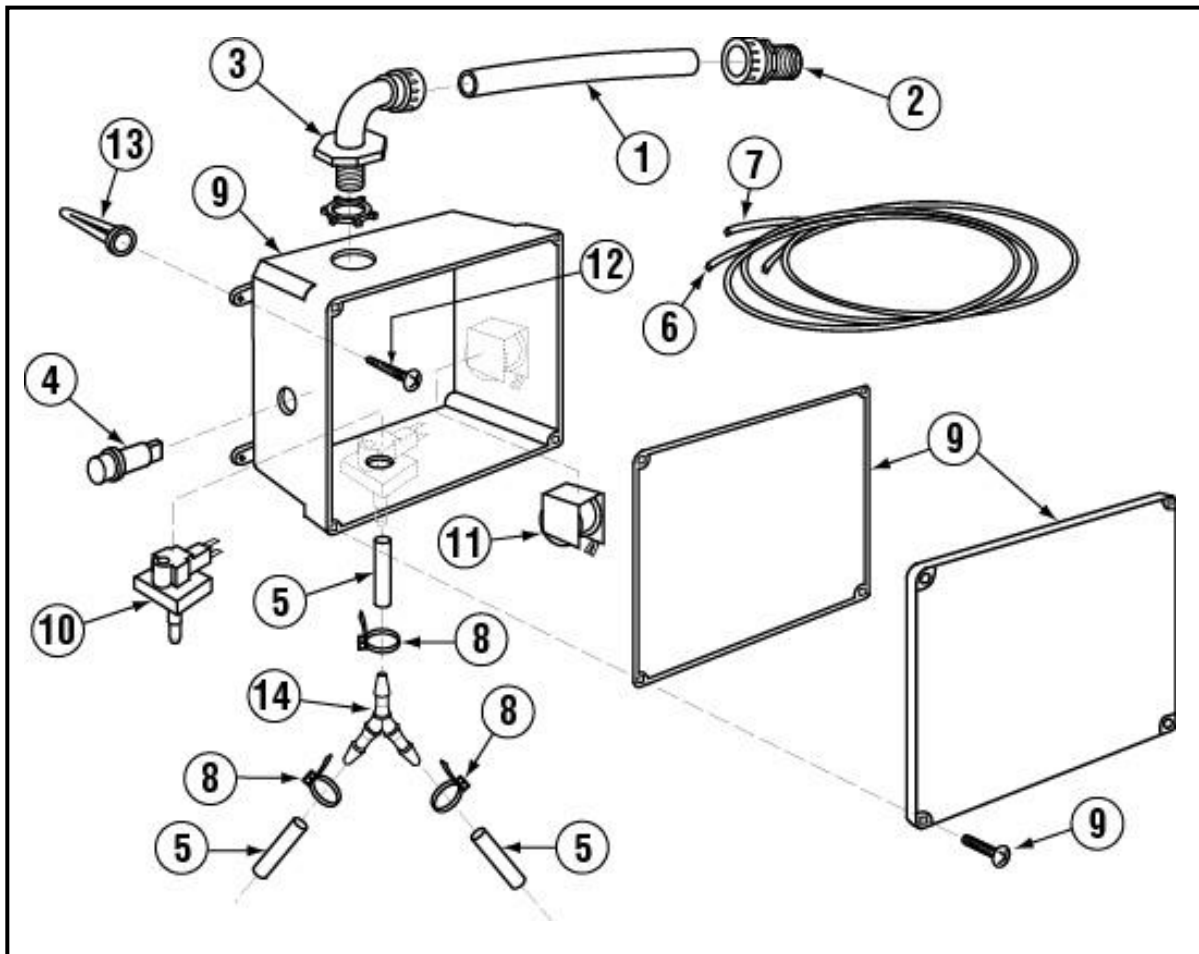

ITEM NO.	NO. REQ'D	P/N	DESCRIPTION
1	3	00400.00	Conduit, 3/8" Sealtite
2	1	00401.00	S.T. 3/8" Straight Connector
3	1	00402.00	S.T. 90 Degree 3/8" Connector
4	1	00406.00	Control Box Light, .5" Diameter, Red
5	1	00435.00	Squeeze Tube, 8"
6	1	00521.00	Wire, 18 Gauge, Orange, 6 ft.
7	1	00531.00	Wire, 18 Gauge, White, 6 ft.

ITEM NO.	NO. REQ'D	P/N	DESCRIPTION
8	5	00931.00	Wire Tie, Small
9	1	12510.00	Sanitizer Alarm Box Assembly
10	1	12511.00	Sanitizer Low Level Vacuum Switch
11	1	12512.00	Sanitizer Alarm Buzzer, 120 Volts
12	4	40126.10	#10 x 3/4" Sheet metal Screw
13	4	40127.00	Wall Anchors
14	1	00426.00	Y Hose Connector, 3/16"