

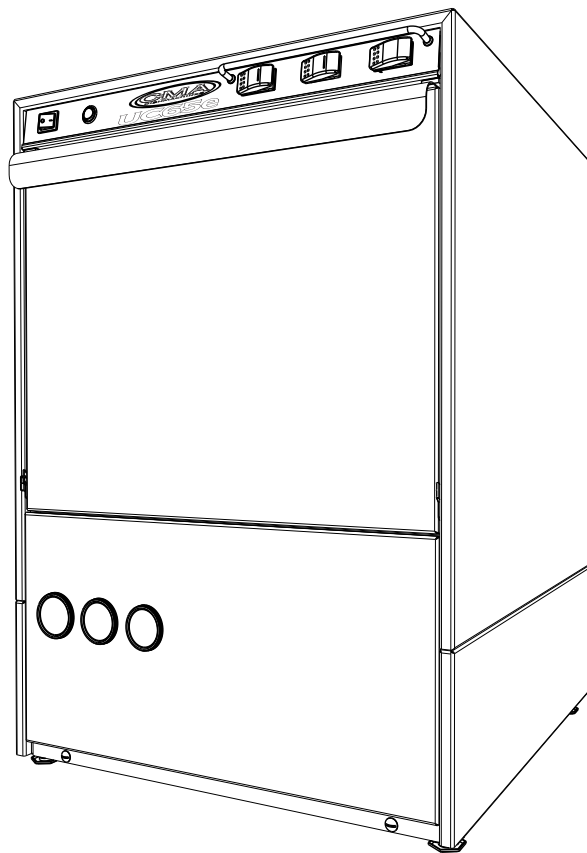

**CMA Dishmachines**  
12700 Knott Avenue  
Garden Grove, CA 92841

Toll Free: 1- (800) 854-6417  
Fax: 1- (714) 895-2141

## Installation/Operation Manual with Service Replacement Parts



### Undercounter High Temperature Dishwasher

Model:

**UC65e M2**



Machine Serial No.



Issue Date: 03.26.20

**Manual P/N 10310.00 rev. G**

For machines beginning with S/N W160861096 and above

0513903/F

CMA Dishmachines  
12700 Knott Avenue  
Garden Grove, CA 92841  
Toll Free: 1 (800) 854-6417  
Fax: 1 (714) 895-2141

Printed in the USA



The Spirit of Excellence

For future reference, record your dishwasher information in the box below.

Model Number_____	Serial Number_____
Voltage_____Hertz_____	Phase_____
Service Agent _____	Tel:_____
Parts Distributor _____	Tel:_____

**National Service Department**

**CMA Dishmachines**  
**12700 Knott Avenue**  
**Garden Grove, CA 92841**  
**Toll-free: 1 (800) 854-6417**  
**Fax: 1 (714) 895-2141**

**ATTENTION:**

The model no., serial no., voltage, Hz and phase are needed to identify your machine and to answer questions.

**The machine data plate is located on the lower front panel.**

Please have this information ready if you call for service assistance.

## Revision History

- The Revision History can contain part number changes, new instructions, or information that was not available at print time.
- We reserve the right to make changes to these instructions without notice and without incurring any liability by making the changes..
- Equipment owners may request a revised manual, at no charge, by calling CMA Dishmachines at 1 (800) 854-6417.

<b>Revision Date</b>	<b>Revised Pages</b>	<b>Serial Number Effectivity</b>	<b>Revision Description</b>
8.25.16	All	W160861096	Released First Edition.
10.10.16	31	All	Changed Item 6 to P/N <a href="#">13658.00</a> .
10.31.16	All	All	Reviewed and updated parts lists.
4.6.17	2	All	Added GFI breaker to Item 2.
9.12.17	17, 48, 49	All	Removed PRV data.
1.2.18	27	All	Reversed P/N's 6 and 7.
3.15.18	22-23	W171072011	Changed Item 15 to P/N 2106.30.
7.18.18	27	All	Reversed P/N's 6 and 7.
1.28.19	50	All	Updated Schematic.

## **Model Description**

### **UC65e M2**

High temperature hot water sanitizing dishwasher with built-in 40°F/22°C rise booster heater.  
208-240VAC/60/1

# Table of Contents

## Model UC65e M2 Undercounter Dishwasher

<i>Revision History</i> .....	<i>i</i>
<i>Model Description</i> .....	<i>ii</i>
<b>Installation</b> .....	<b>1</b>
<i>Receiving</i> .....	1
<i>Electrical Connections</i> .....	2
<i>Water Connections</i> .....	4
<i>Drain Connections</i> .....	4
<b>Initial Start-up</b> .....	<b>6</b>
<i>Check List</i> .....	6
<i>Chemical Dispensing Pumps</i> .....	7
<i>Priming</i> .....	9
<i>Adjusting</i> .....	10
<b>Operation</b> .....	<b>11</b>
<i>Normal Wash Mode</i> .....	11
<i>Safe-T-Temp</i> .....	12
<b>Cleaning and Maintenance</b> .....	<b>13</b>
<i>Cleaning</i> .....	13
<i>Deliming</i> .....	15
<i>Maintenance</i> .....	16
<i>Troubleshooting</i> .....	17
<b>Service Replacement Parts</b> .....	<b>19</b>
<b>Electrical Schematic</b> .....	<b>50</b>
<b>Timing Chart</b> .....	<b>51</b>

***This Page  
Intentionally  
Left Blank***

## Receiving

### NOTE:

The installation of your dishwasher must be performed by qualified service personnel. Problems due to improper installation are not covered by the Warranty.

1. Inspect the outside of the dishwasher carton for signs of damage.
2. Remove the carton and inspect the dishwasher for damage.
3. Check for any accessories that may have shipped with your dishwasher.
4. Move the dishwasher near its permanent location.

### NOTE:

The installation of the dishwasher must comply with all local electrical, plumbing, health and safety codes or in the absence of local codes, installed in accordance with the applicable requirements in the National Electrical Code, NFPA 70, Canadian Electrical Code (CEC), Part 1, CSA C22.1; and the Standard for Ventilation Control and Fire Protection of Commercial Cooking Operations, NFPA 96.

### CAUTION:

Be careful when lifting and moving the dishwasher to prevent damage to the machine.

### NOTE:

The installation of the dishwasher must comply with local health codes.

5. Compare the installation site utility connections with the dishwasher utility connections and make sure that they are the same.
6. The dishwasher can be installed as a free-standing unit or under a built-in counter-top. The typical counter-top height in most locations is 34" [86cm].
7. Under counter installations should provide storage space for the dishwasher chemical supply containers. Containers must not be placed higher than 10" [25cm] above the floor.
8. Chemical supply containers should be placed as close as possible to the machine as possible.
9. Place the dishwasher in its permanent location.
10. The dishwasher has 4 adjustable feet for leveling.
11. Level the dishwasher front-to-back and side-to-side.

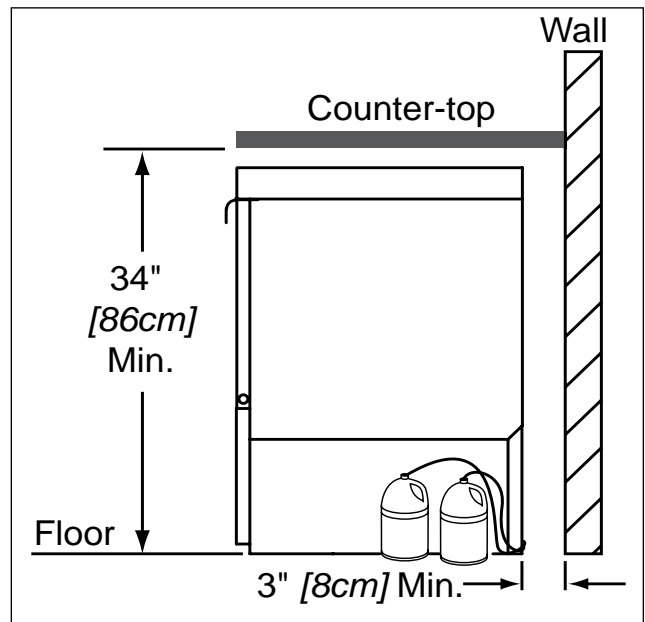

## Electrical Connections



**WARNING:** Electrocutation may occur when working on energized circuits. Disconnect power at the main breaker or service disconnect switch, then lock out and tag it to indicate that work is being performed on the circuit.

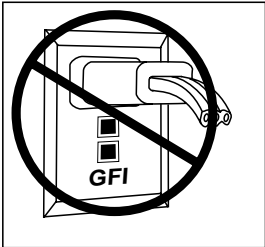

**CAUTION:** Permanent damage to the dishwasher may occur if it is improperly connected to the main electrical supply. Never install a power cord and plug to the dishwasher or connect the dishwasher to a standard or GFI electrical outlet or GFI electrical breaker. The dishwasher must be hard-wired to a dedicated appropriately sized circuit breaker or service disconnect switch.

1. Check the electrical specifications on the machine data plate then remove the lower front panel to access the power input terminal block on the base of the machine.
2. Do not use a power cord and plug or connect to a standard or Ground Fault Interrupter (GFI), electrical outlet or a Ground Fault Interrupter (GFI) breaker. The dishwasher must be hard-wired to a junction box or service disconnect switch.

40°F/22°C Rise Electric Booster (4kW)

Elec. Specs	Rated Amps	Minimum Supply Circuit Ampacity	Maximum Overcurrent Protective Device (Breaker Size)
208/60/1	22	30	30
240/60/1	24	30	30

70°F/39°C Rise Electric Booster (6kW)

Elec. Specs	Rated Amps	Minimum Supply Circuit Ampacity	Maximum Overcurrent Protective Device (Breaker Size)
208/60/1	29	40	40
240/60/1	31	40	40

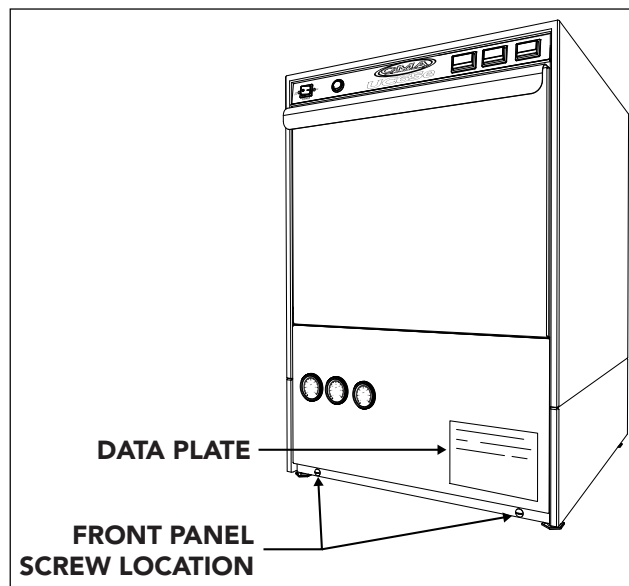

## Electrical Connections

**NOTE:** A qualified electrician must connect the main incoming power to the dishwasher in accordance with all local codes and regulations or in the absence of local codes in accordance with the National Electrical Code.

**FOLLOW THE STEPS BELOW TO CONNECT THE INCOMING POWER.**

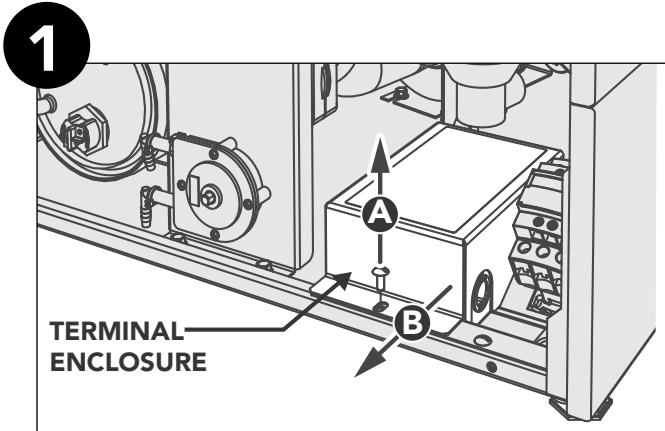

- Ⓐ REMOVE THE LEFT SCREW ON THE FRONT LIP OF THE TERMINAL BOX.
- Ⓑ LIFT AND REMOVE THE COVER TO ACCESS THE TERMINAL BLOCK.

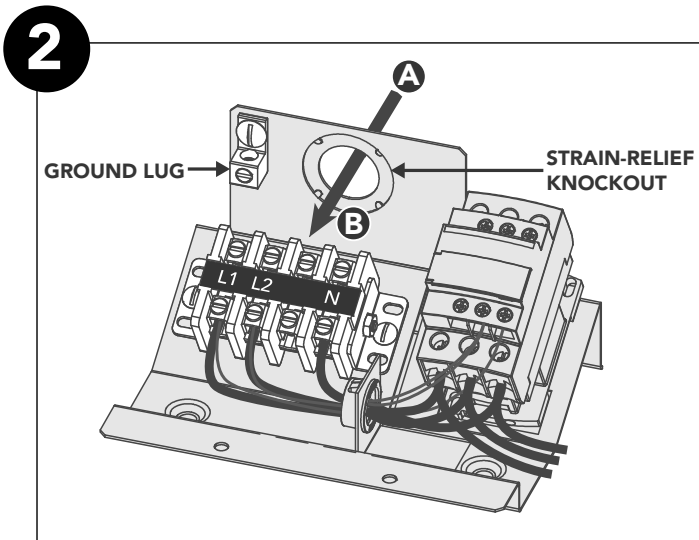

A 30" / 76 cm SERVICE LOOP MUST BE PROVIDED BEHIND THE UNIT FOR SERVICING.

- Ⓐ THREAD THE POWER CABLE THROUGH THE MIDDLE SLOT IN THE DISHWASHER REAR PANEL.
- Ⓑ SECURE THE CABLE TO THE TERMINAL BOX USING THE PROPER STRAIN RELIEF.

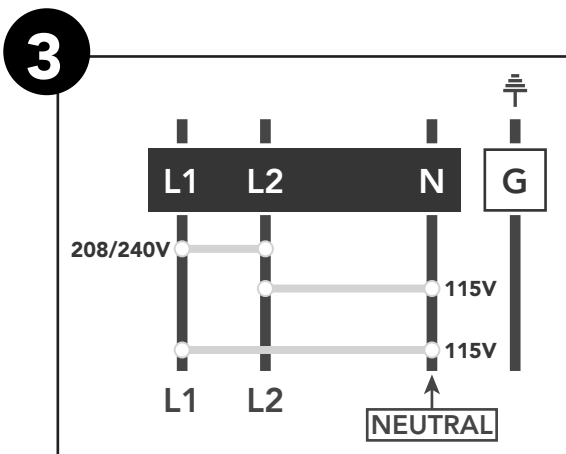

CONNECT THE INCOMING POWER AS SHOWN AT LEFT.

208-240V/60Hz/1  
THREE POWER WIRES WHICH INCLUDES A CURRENT CARRYING NEUTRAL. AN ADDITIONAL WIRE MUST BE PROVIDED FOR MACHINE GROUND.

## Installation

### Water Connections

**NOTE:**

Plumbing connections must comply with national or local plumbing and sanitary codes. Make sure that the flexible water supply and drain hoses are not kinked.

1. All models have a 6 ft. flexible hot water fill hose with a 3/4" GHT connector.
2. A 1/2" or larger main incoming supply line should be installed to the dishwasher.
3. A 1/2" or larger shut-off valve should be installed in the water supply line as close to the dishwasher as possible for service.
4. The hot water supply must provide a minimum of 140°F/60°C, measured at the dishwasher for the 40°F/ 22°C rise booster.
5. For the 70°F/39°C rise booster the hot water supply must provide a minimum of 110°F/43°C measured at the dishwasher.
6. A water hardness of 3 grains/U.S. gal [51.3 mg/L] or less is recommended.

**! ATTENTION !**

Do not connect the drain hose to a disposer. The dishwasher will not drain correctly.

### Drain Connections

1. The dishwasher has a 6ft. 3/4" I.D. drain hose. The maximum drain height connection must not exceed 3 ft. [9 m].  
The recommended drain height is 18" [.4 m] or less above the floor.
2. The drain hose is secured to the rear of the machine by a clamp to maintain a goose-neck bend in the drain hose.
3. A 3/4" hose barb fitting is strapped to the drain hose to use in connecting the drain hose to building drain line.  
The service part number for the hose barb is P/N 0512321.

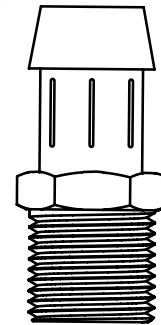

4. Install the drain hose to a "WYE" drain fitting. Connection to a "TEE" fitting will prevent the dishwasher from draining completely.
5. The maximum drain flow is 8 U.S. gpm/7 Imp. gpm/30 L.P.M.
6. Make sure the drain hose does not kink. Kinks will prevent the dishwasher from draining completely, and the dishwasher will overflow out the front door.

## Drain Connections

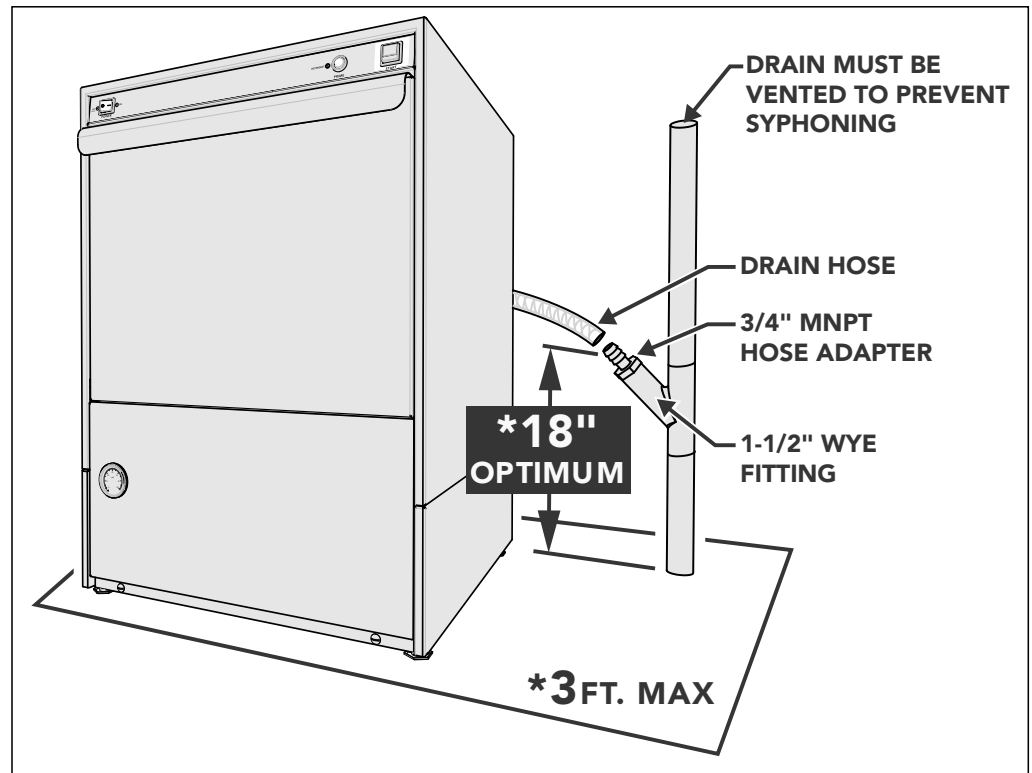

*The dishwasher flexible drain hose must be connected to a WYE FITTING.*

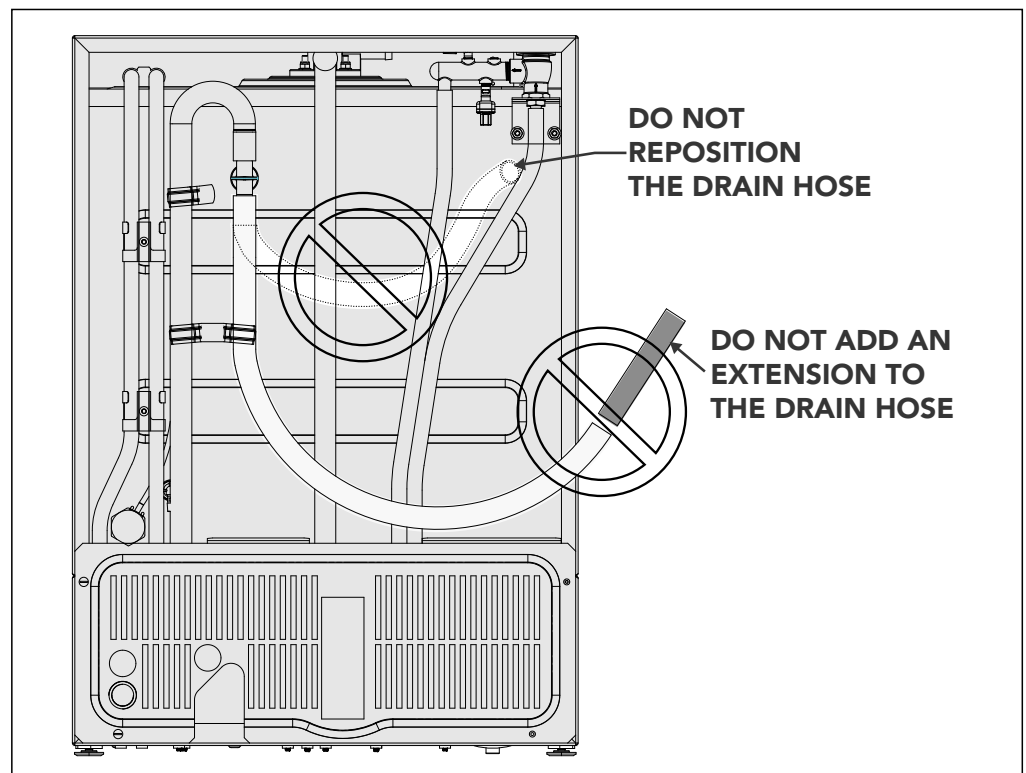

## Initial Start-up

### Check List

1. Remove any protective film from dishwasher. Check the interior for foreign material.
2. Make sure that the dishwasher is permanently located.
3. Make sure that all utility connections are complete.
4. Make sure that the flexible drain hose and the hot water fill hose are not kinked.
5. Make sure that the chemical supply containers are full and that the chemical pick-up tubes are installed in the proper containers.
6. Make sure that the sump filter is in place.
7. Make sure that the overflow tube is installed and firmly seated in the sump.
8. Make sure that the spray arms are in place and that they spin freely.
9. Fully close the dishwasher door.
10. Turn hot water supply on and check for leaks in the main water supply piping connected to the dishwasher.

**! IMPORTANT !**  
**During the initial fill, the flowing pressure of the incoming water is set to 20-22 PSI.**

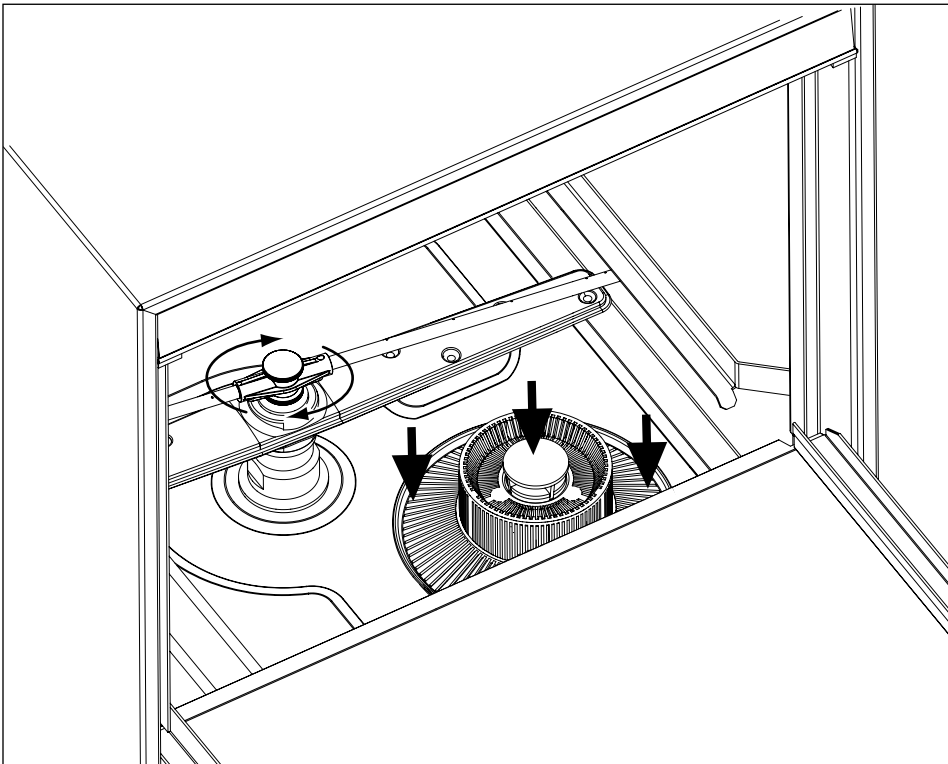

*Install the scrap screen, overflow tube, and spray arms.  
Make sure the spray arms turn freely.*

## Chemical Dispensing Pumps

### ! ATTENTION !

Contact a local chemical supplier for detergent and rinse-aid chemicals. The detergent should be a non-chlorinated liquid detergent. The chemical dispensing pumps are adjusted by the chemical supplier.

1. The dishwasher is equipped with a built-in detergent dispensing pump and rinse-aid dispensing pump. (See the photographs below.)
2. The pumps are located on the lower panel behind the lower-front access panel.
3. Each pump is equipped with 6 feet [1.8 m] of pick-up supply tubing, a stiffener tube, and a strainer.
4. A red label marked DETERGENT is attached to the detergent pump inlet tubing.
5. A blue label marked RINSE-AID is attached to the rinse-aid pump inlet tubing.
6. The detergent enters the wash tank compartment through a fitting at the right rear of the wash compartment. (See the illustration on the next page).
7. The detergent supply should be a non-chlorinated liquid detergent.

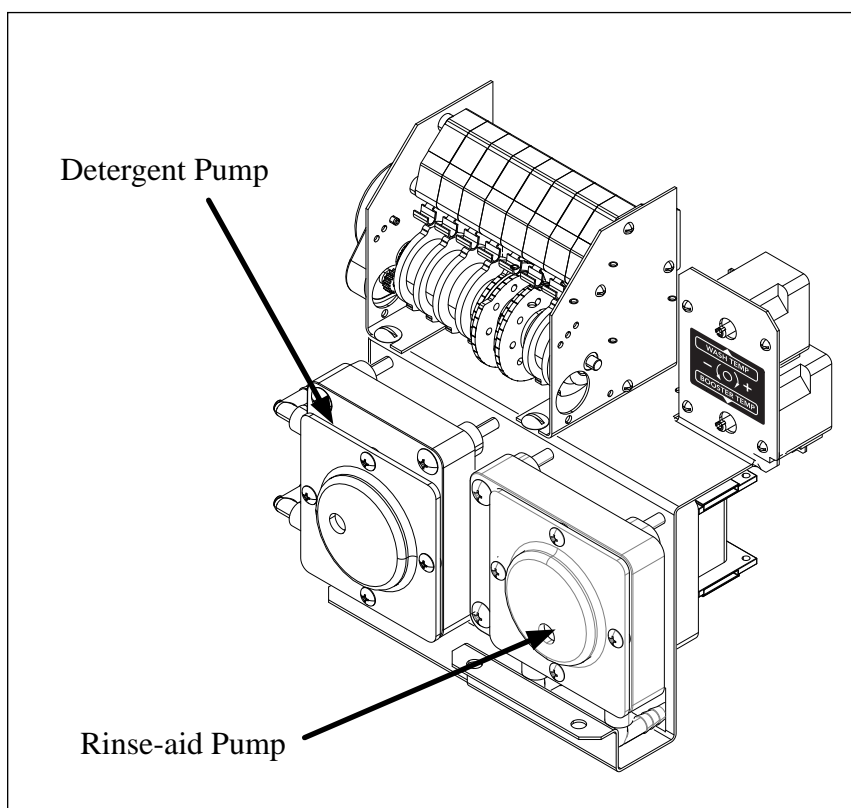

The dispensing pumps are located behind the front panel.

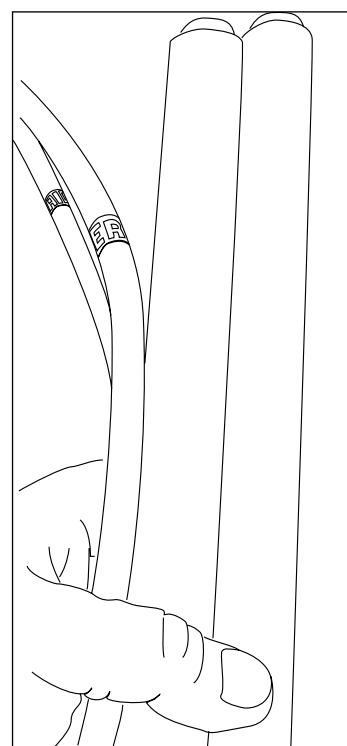

A stiffener tube, strainer and pick-up tubing are supplied with the built-in detergent and rinse-aid pumps.

## **Chemical Dispensing Pumps (continued)**

8. The rinse-aid enters the final rinse piping through a fitting located on the upper-left rear side of the dishwasher. The fitting is located near the vacuum breaker. The chemical supplier will choose the appropriate liquid rinse-aid.
9. Your chemical supplier should adjust the dispensers for the supplied product.
10. Place the chemical supply containers as close to the dishwasher as possible.
11. Do not elevate the chemical containers above the finished floor.

## **Chemical Injection Points**

The illustrations below show the location of the detergent and the rinse-aid injection points.

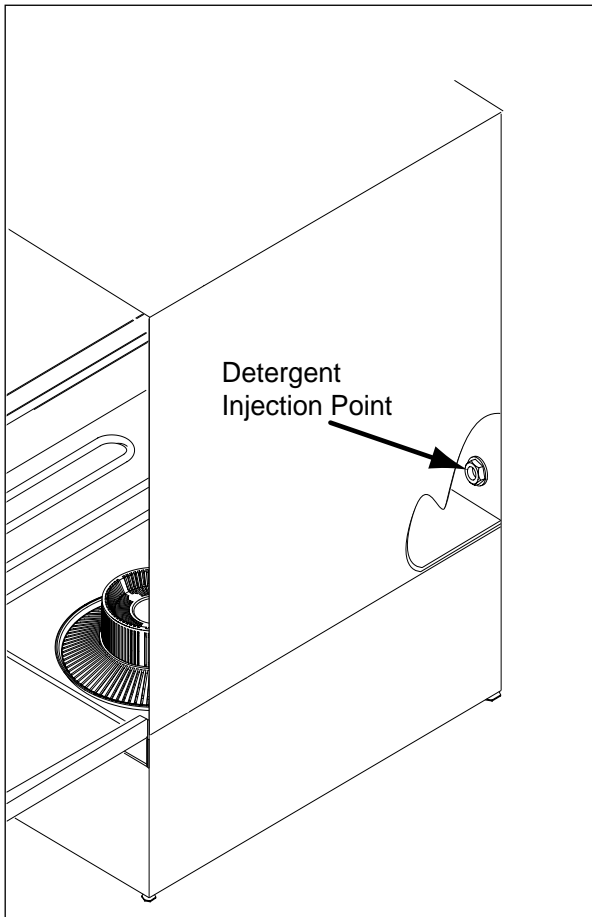

*Detergent enters the wash tank compartment through a fitting on the rear wall of the wash tank compartment.*

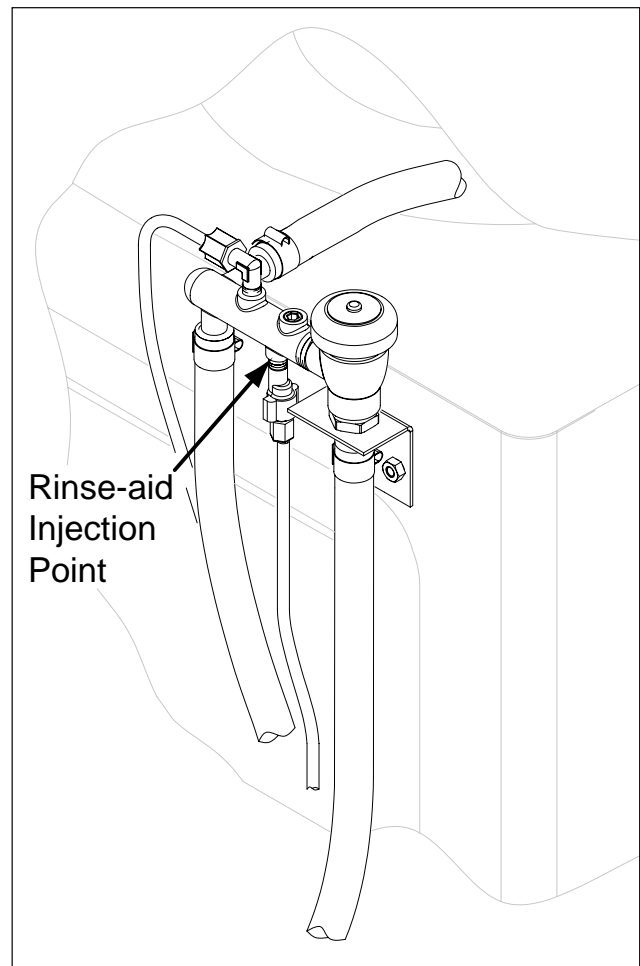

*The rinse-aid enters the final rinse piping at the top-rear of the dishwasher near the vacuum breaker.*

## Chemical Dispensing Pumps

### Priming the Chemical Dispensing Pumps

The chemical dispensing pumps must be primed during initial start-up and whenever a chemical container. A momentary two position PRIME switch is located on the front control panel to do this. The Detergent dispensing pump is primed when the Prime switch is pushed UP to the DET position. The Rinse-aid dispensing pump is primed when the Prime switch is pushed DOWN to the R/A position.

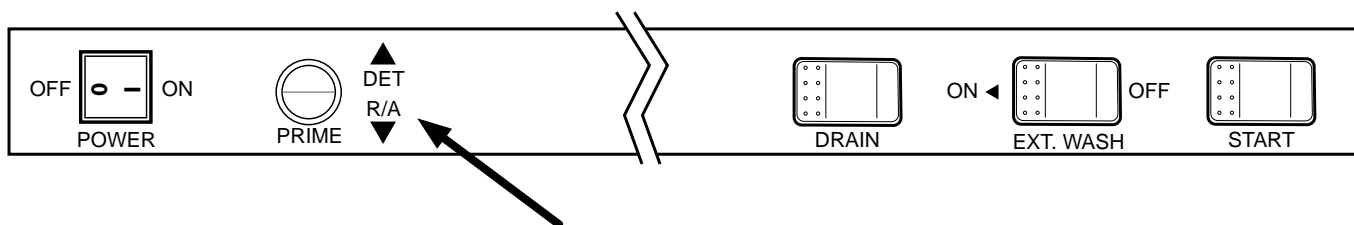

### Chemical Dispenser Prime Switch

1. Make sure the chemical containers are full and the correct pick-up tubes are in the containers.
2. Turn the dishwasher power switch ON. The switch will illuminate and the dishwasher will fill with water.
3. Once the fill is complete, open the dishwasher door, then push and hold the prime push button UP to the DET (detergent) position until detergent is observed entering at the right-rear of the wash tank compartment.
4. Push and hold the prime push button DOWN to the R/A (rinse-aid) position for thirty seconds. Release the push button.
5. Close the door.

## Chemical Dispensing Pumps

### Adjusting the Chemical Dispenser Pumps

The amount of detergent and rinse-aid that are dispensed during the dishwasher cycle are controlled by adjustable cams on the timer assembly. Variables such as the type of chemicals used and the hardness of the water supply often require that the timer cam settings must be changed. It is recommended that the chemical supplier make these adjustments. (Refer to the illustration below).

#### NOTE:

Only the Detergent and the Rinse-aid cams are adjustable. Do not attempt to adjust any other timer cam.

To adjust the chemical dispensing pump timer cams:

1. Remove the lower-front access panel. The timer assembly is located on the right-side of the electrical component panel.
2. Make sure the dishwasher power is OFF.
3. The detergent timer cam has 2 halves. Hold the stationary right-half of the cam and turn the left-half of the cam counter-clockwise to increase the amount of detergent that is dispensed. Turn the left-half clockwise to decrease the detergent dispensed.
4. The rinse-aid timer cam has 2 halves. Hold the stationary left-half of the cam and turn the right-half of the cam counter-clockwise to decrease the amount of rinse-aid that is dispensed. Turn the right-half clockwise to increase the amount of rinse-aid dispensed.

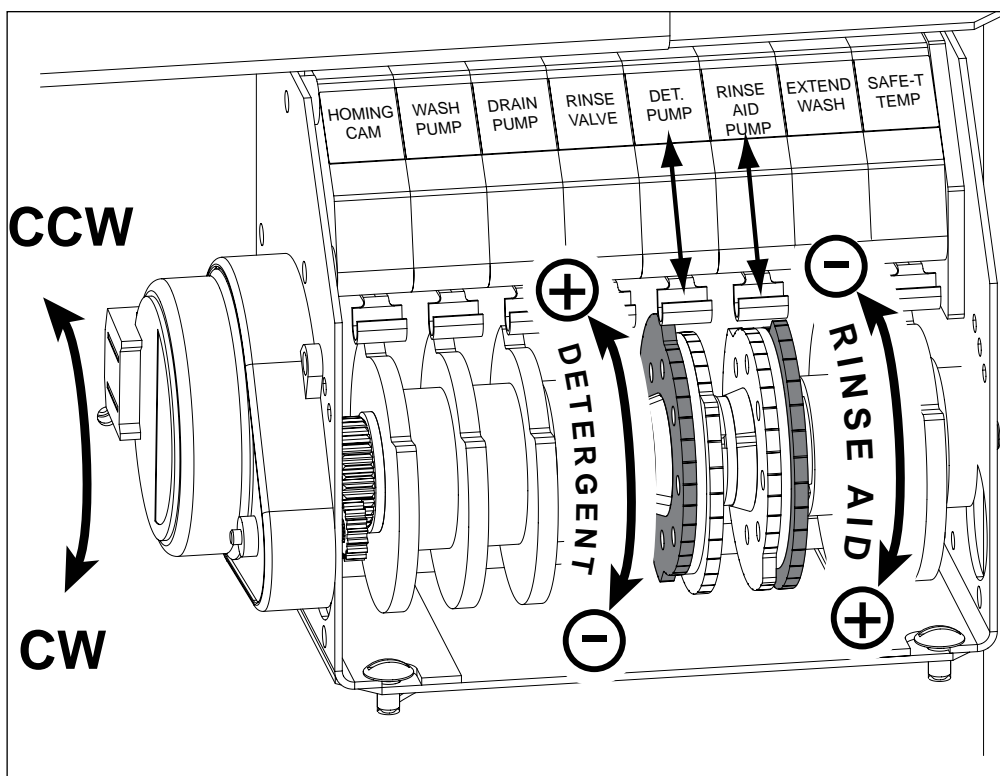

## Normal Wash Mode

Follow the instructions below to operate the dishwasher in a Normal Wash Mode. A Safe-T-Temp feature holds the dishwasher in a wash mode if the booster heater temperature is below 180°F/82°C.

1. Turn the main power on at the main circuit breaker.
2. Install the sump filter, overflow tube and spray arms.
3. Make sure the flexible drain hose and the flexible fill hose are not kinked, then turn the water supply on.
4. Close the dishwasher front door.
5. Push the dishwasher Power Switch to the ON position. The power switch will illuminate and the machine will fill with water.
6. Check the pressure gauge as the machine fills and make sure the incoming water pressure is between 20-22 psi.
7. Wait 15-minutes for the WASH temperature gauge to indicate a minimum of 150°F/66°C.
8. At the beginning of the day, run 2 empty cycles before checking the final rinse operating temperature. The first cycle will take longer to reach the proper temperature.

### **! ATTENTION !**

If the wash temperature is low for an extended period of time, drain the machine and refill with fresh water. Run two empty cycles and then check that the wash tank temperature gauge indicates 150°F/66°C.

9. Load soiled wares into the dish rack. Place plates, glasses, cups and bowls in a peg rack. Place utensils in a single layer in a flat-bottom rack. Place pots and pans in a flat-bottom rack. Do not overload the dish racks.
10. Slide 1 dish rack into the wash compartment making sure that wares do not interfere with the rotating spray arms. Do not wash more than 1 dish rack at a time.
11. Close the front door fully, then press and hold the START BUTTON for 1-second. The green in-cycle light will illuminate and the wash cycle will begin. The wash cycle time runs for approximately 1-1/2 minutes. (continued on next page)

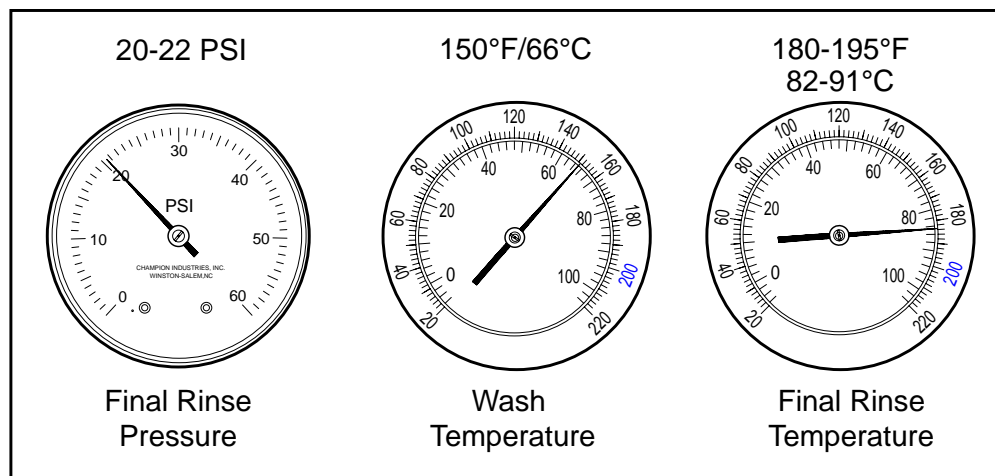

*The pressure and temperature gauges are located on the lower-left corner of the lower-front access panel.*

## Operation

### Normal Wash Mode (continued)

12. Opening the door when the dishwasher is in-cycle will stop the dishwasher. The cycle will resume automatically when the dishwasher door is closed fully.
13. The final rinse cycle begins at the end of the wash cycle and runs for approximately 15 seconds. Check the RINSE temperature gauge during the final rinse and make sure that it indicates a minimum of 180°F/82°C. The acceptable range of operation is 180-195°F/82-91°C.
14. At the end of the rinse cycle, the in-cycle light will go out. Open the door and remove the clean rack of wares. Repeat steps 8-12 for additional dish racks.
15. Refer to the Cleaning Instructions, "After Each Meal Period or every 8 Hours of Operation", on page 15 for the procedures to drain and clean the dishwasher.

### Safe-T-Temp Mode

The final rinse water temperature must be a minimum of 180°F/82°C during the final rinse cycle to ensure that all wares are sanitized. If for any reason, the hot water temperature in the booster tank cannot provide this temperature, the dishwasher will enter a Safe-T-Temp Mode of operation and extend the cycle time.

The Safe-T-Temp changes the Normal Operation Mode as described below:

1. The Safe-T-Temp constantly monitors the water temperature inside final rinse booster.
2. If the temperature inside the booster heater falls below 180°F/82°C then the Safe-T-Temp will extend the wash cycle time until the booster heater water temperature reaches the proper temperature.
3. The in-cycle light will remain illuminated during the Safe-T-Temp Mode.
4. The RINSE water temperature gauge must be monitored to ensure that a minimum of 180°F/82°C is maintained during the rinse cycle.
5. The temperature range for the final rinse water is 180-195°F/82-91°C.
6. An extraordinarily long wash cycle may indicate a low incoming water temperature or a problem with the booster heater operation.

**DO NOT REMOVE WARES UNTIL THE FINAL RINSE CYCLE HAS SANITIZED THE WARES AND THE GREEN CYCLE LIGHT GOES OUT.**

### Extended Wash Mode

The Extended Wash Mode is used to wash heavily soiled items such as pots, pans and other wares that require more washing time than the standard 100-second Normal Wash Mode.

The dishwasher will remain in the Extended Wash Mode until the operator exits the mode.

1. Load a dish rack into the dishwasher, close the door.
2. Press and hold the START button for 1-second then release.
3. The green in-cycle light will illuminate and the dishwasher will begin a normal wash cycle.
4. Press the EXT WASH button to place the dishwasher in the Extended Wash Mode.
5. The green extended wash light will illuminate indicating that the machine is in the Extended Wash Mode.
6. The dishwasher will continue to wash until the operator presses the EXT WASH button again.
7. Press the EXT WASH button. The green extended wash light will go out indicating that the dishwasher has returned to the Normal Wash Mode.
8. The dishwasher will finish the wash cycle and perform a final rinse of the wares.

## Cleaning

### After Each Meal Period or every 8 Hours of Operation.

1. Press the lighted power switch to the OFF position. The power switch light will go out.
2. Open the door and remove the overflow tube from the wash tank sump.
3. Inspect and clean the overflow tube rubber seal
4. Close the door.
5. Push and hold the drain switch until all of the water has drained.
6. Remove the sump filter carefully to keep the soil or waste particles from falling into the sump.
7. Clean the sump filter by rinsing with clean water.  
Be sure to back-flush the filter.  
Do not strike the filter against solid objects.
8. Check the sump for foreign material and clean as required.
9. Replace sump filter and the overflow tube.
10. Make sure that spray arms turn freely.
11. Check the chemical containers and refill as required.
12. Close the door and turn the ON/OFF switch to ON and return to normal operation mode.

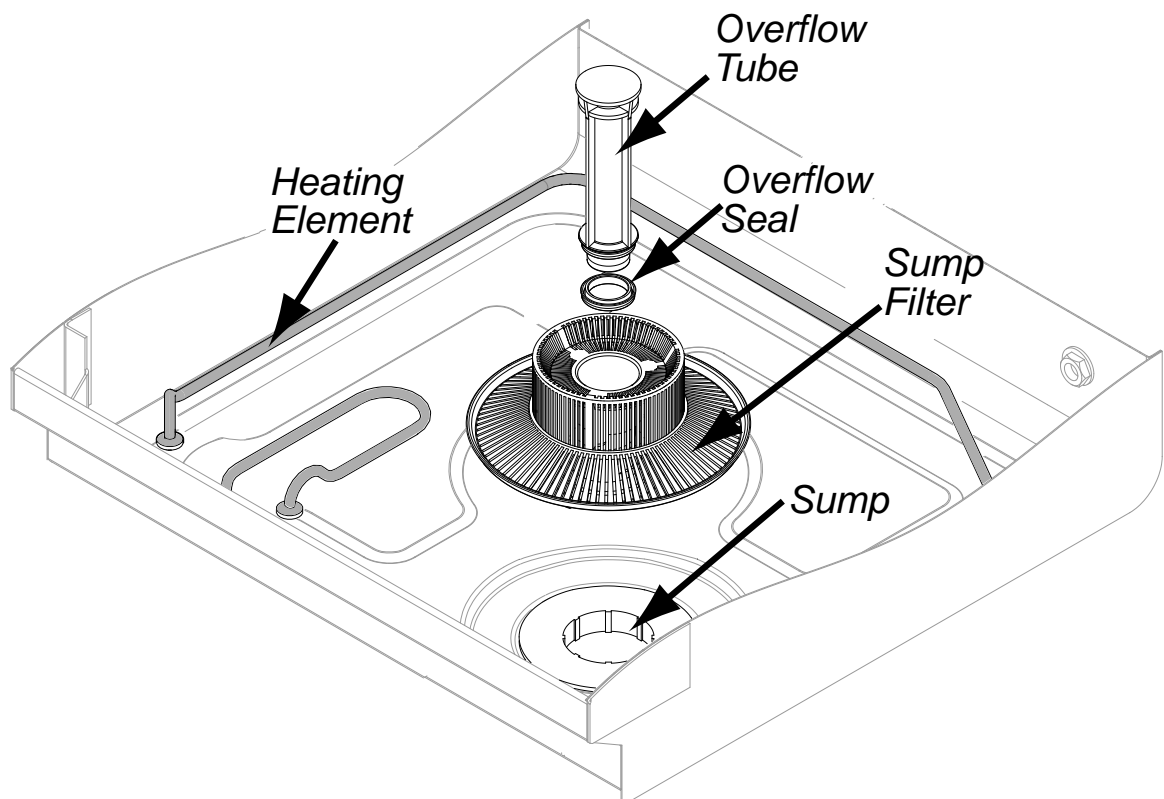

## **Cleaning**

### **At the End of the Day**

1. Perform Steps 1-8 on the previous page.
2. Remove the upper and lower rinse and wash spray arms. The spray arms are interchangeable.
3. Unscrew the rinse arm pin (A). Remove the rinse arm assemblies
4. Clean the final rinse arm nozzles using a small paper clip (B).
5. Remove the rinse arm end plugs (C) *if necessary*, and flush the rinse arm with clean water.
6. Re-install the rinse arm end plugs if they were removed.
7. Remove the wash spray arms and flush with clean water.
8. DO NOT USE STEEL WOOL TO CLEAN THE INTERIOR OF THE MACHINE.
9. Contact the chemical supplier for Deliming if required (see next page).
10. Wipe the interior and exterior of the machine with a soft cloth and a mild detergent. DO NOT HOSE THE EXTERIOR OF THE MACHINE WITH WATER.
11. Reassemble the dishwasher and leave the door open to allow overnight drying.

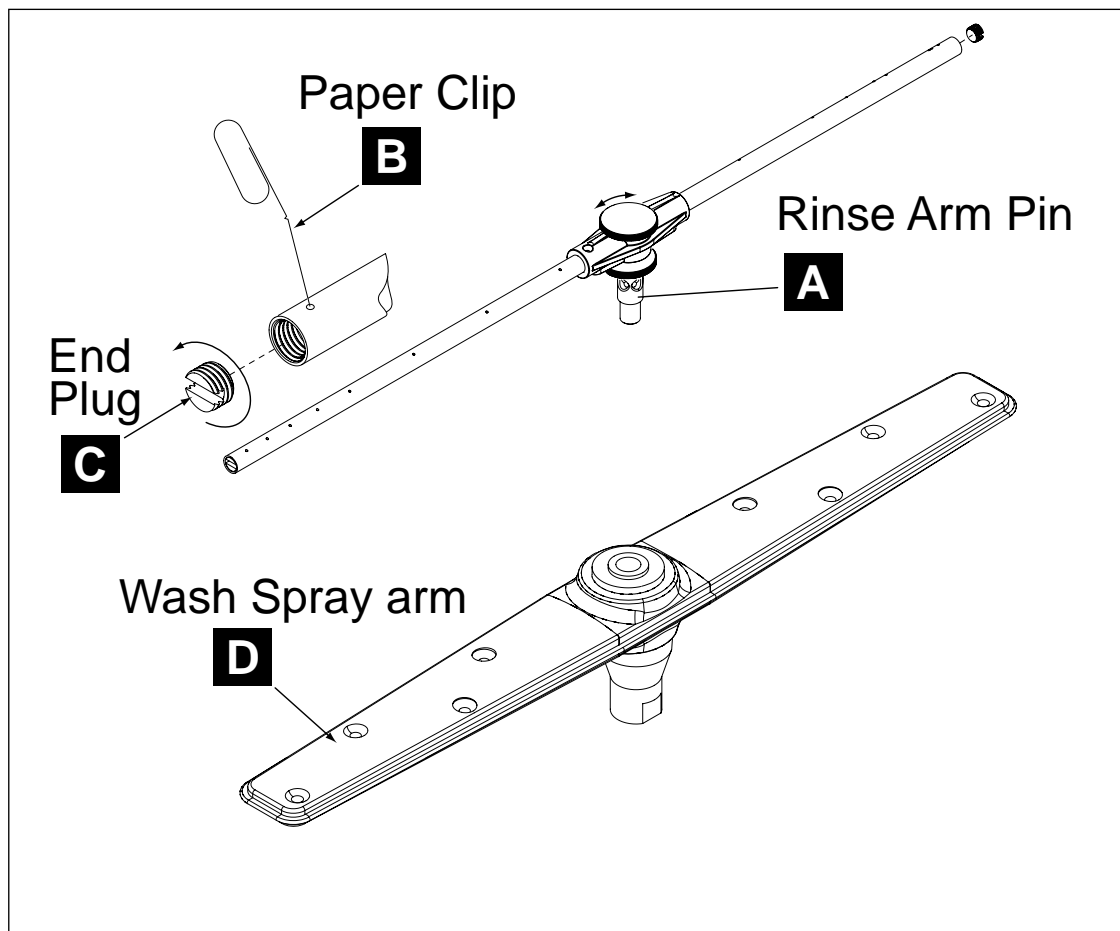

## Deliming

Minerals accumulate on the interior surfaces of the dishwasher. The deposits have a white haze and, in cases of heavy accumulation, may appear as a granular solid. The generic name for mineral deposits is lime. The removal of lime deposits is called Deliming. Your dishwasher should be delimed regularly; how often will depend on the mineral content of your water.

Inspect your machine interior for lime deposits. If deliming is required, a Deliming agent should be used for best results in accordance with the chemical supplier's instructions.

### **DANGER:**

Death or serious injury may result when Deliming solution is mixed with sodium hypochlorite (*chlorine bleach*) sanitizing agent. Mixing may cause hazardous gases to form.

Deliming solution and other acids must never be mixed with chlorine, iodine, bromine, or fluorine.

### **CAUTION:**

Skin contact with Deliming solutions can cause severe irritation and possible chemical burns. Always wear protective clothing and goggles when handling chemicals.

### **NOTE:**

Contact your chemical supplier for specific safety procedures and instructions for the use of the Deliming solution supplied for the dishwasher.

Deliming solution or other chemicals are not supplied by the dishwasher manufacturer.

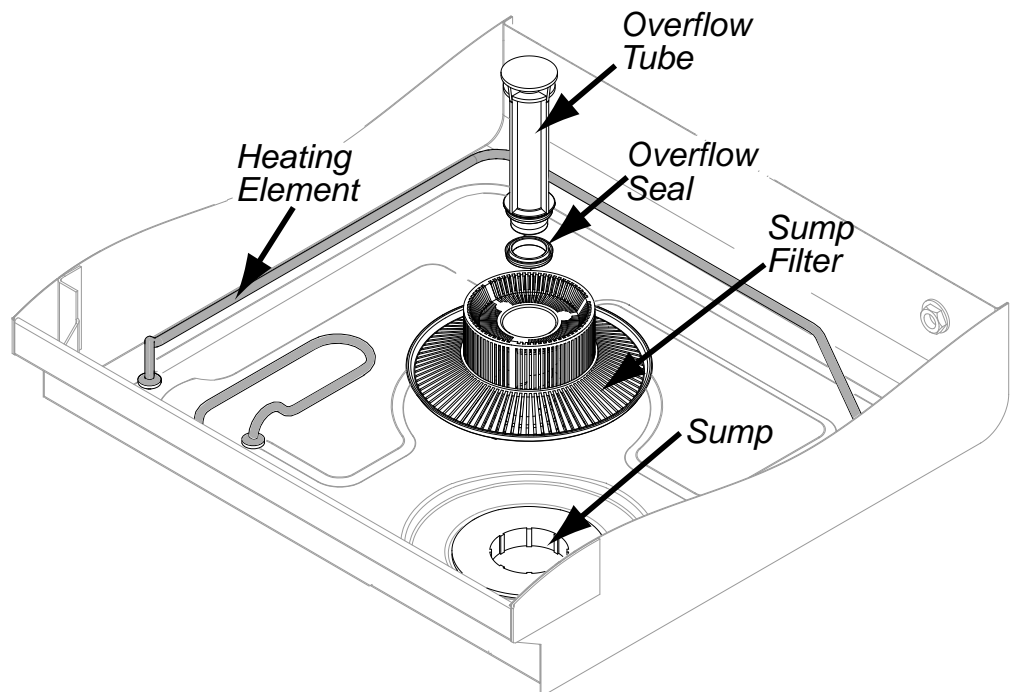

### **Maintenance**

Follow the maintenance schedules below to keep the dishwasher operating most efficiently.

#### **Daily Maintenance**

1. Check all of the wash arm and rinse arm spray jets and clean as necessary.
2. Make sure that the water supply is on and that the drain is not clogged.
3. Check the temperature gauges and/or displays to ensure that they are operating.
4. Make sure that dish racks are in good condition.
5. Check the chemical containers and refill as required.
6. Follow the cleaning procedures given above.

#### **Weekly Maintenance**

1. Perform Steps 1-5 in the Daily Maintenance.
2. Inspect water lines for leaks.
3. Check for water leaks underneath the dishwasher.
4. Make sure the flexible water fill and drain hoses are not kinked.
5. Make sure that the dishwasher is level.
6. Clean accumulated lime deposits from the wash tank heating element.
7. Inspect the scrap screen and replace it if damaged.
8. Check the spray arms and replace or repair if damaged.
9. Clean the chemical dispenser pick-up tubing for the detergent and rinse-aid pumps.

#### **To clean the pick-up tubing:**

1. Remove the pick-up tubes from their containers.
2. Place each tube in a separate container of hot water.
3. Press and hold the PRIME button up in the DET position until water flows into the wash tank compartment.
4. Press and hold the PRIME button down in the RINSE position until water flows into the wash tank compartment.
5. Return the pick-up tubes to their containers.
6. Run 3 empty dishwasher cycles to flush any chemicals from the dishwasher wash compartment.
7. Push and hold the chemical prime button to prime the chemical pumps.

**Troubleshooting**

Follow the troubleshooting guide below in the event that your dishwasher does not operate as expected. Perform the basic checks below before calling an authorized service agent:

1. Make sure that the main water supply is turned on.
2. Make sure that the main power is turned on.
3. Make sure that the flexible water fill and drain hoses are not kinked.

Condition	Cause	Solution
Dishwasher will not run.	Door not closed. Main power OFF. Dishwasher OFF.	Close door completely. Check breaker on panel. Turn dishwasher ON.
Low or no water.	Main water supply off. Solenoid strainer clogged. Solenoid valve defective.	Open supply valve. Clean strainer. Contact Service Agent.
Chemicals won't feed into dishwasher.	Chemical supply low. Pick-up tube clogged Supply tubing damaged. Supply tubing kinked.	Refill chemical container. Clean/replace tube. Replace tubing. Straighten tubing.
Poor wash results.	Wares incorrectly loaded. in dishrack.  Clogged sump filter. Clogged spray arms.  Detergent injector not feeding.  Thermostat defective.  Detergent motor defective.  Water temperature low.	Reposition wares or reduce amount of wares.  Clean sump filter. Clean spray arms.  Replace squeeze tube or clean tubing and pick-up tube.  Contact Service Agent.  Contact Service Agent  Contact Service Agent
Dishwasher stays in wash cycle.	Safe-T-Temp extends wash mode to allow final rinse water booster temperature to reach 180°F/82°C.  Dishwasher is operating in the Extended Wash Mode.	Contact Service Agent because booster thermostat is defective.  Press the Extended Wash button 1 time. The Extended Wash Indicator light will go out, the wash cycle will resume where it left off and perform a final rinse cycle.

***This Page  
Intentionally  
Left Blank***

# Service Replacement Parts

<i>Illustrations</i>	<i>Page</i>
Wash Pump/Motor .....	20
Booster .....	22
Power Box Wiring .....	24
Electrical Panel and Timer .....	26
Control Panel.....	28
Upper Final Rinse Piping.....	30
Wash and Rinse Spray Arms.....	32
Drain Pump and Hoses .....	34
Wash Tank Heater and Drain.....	36
Fill Solenoid Valve .....	38
Detergent Pump .....	40
Rinse-aid Pump .....	42
Panels.....	44
Door.....	46
Dish racks, Line Strainer .....	48

# Wash Pump/Motor

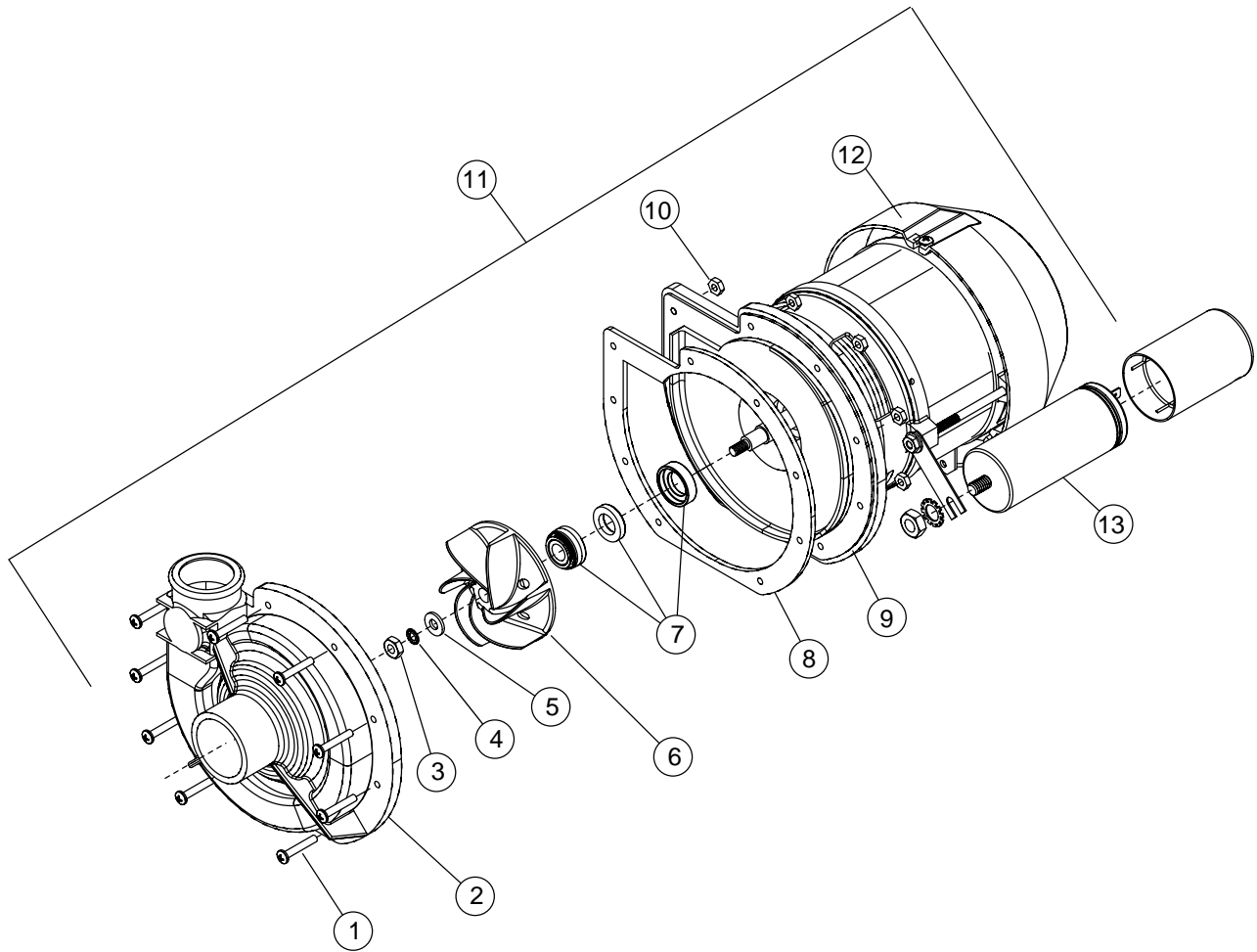

Item No.	Part No.	Description	Qty.
1	02103.01	SCREW, M4, PHIL, PAN HEAD.	9
2	02103.02	IMPELLER HOUSING COVER	1
3	02103.03	NUT, M6 (left-hand threads)	1
4	02103.04	WASHER, LOCK, 1/4"	1
5	02103.05	WASHER, PLAIN, M6	1
6	02103.06	IMPELLER	1
7	02103.07	SEAL	1
8	02103.30	GASKET, PUMP	1
9	02103.09	BACKPLATE, PUMP	1
10	02103.08	NUT, M4	9
11	02103.10	PUMP/MOTOR ASSEMBLY COMPLETE, 220VAC/60/1	1
12	02103.37	COVER, REAR MOTOR FAN	1
13	02103.11	CAPACITOR 16 $\mu$ F	1

# Booster

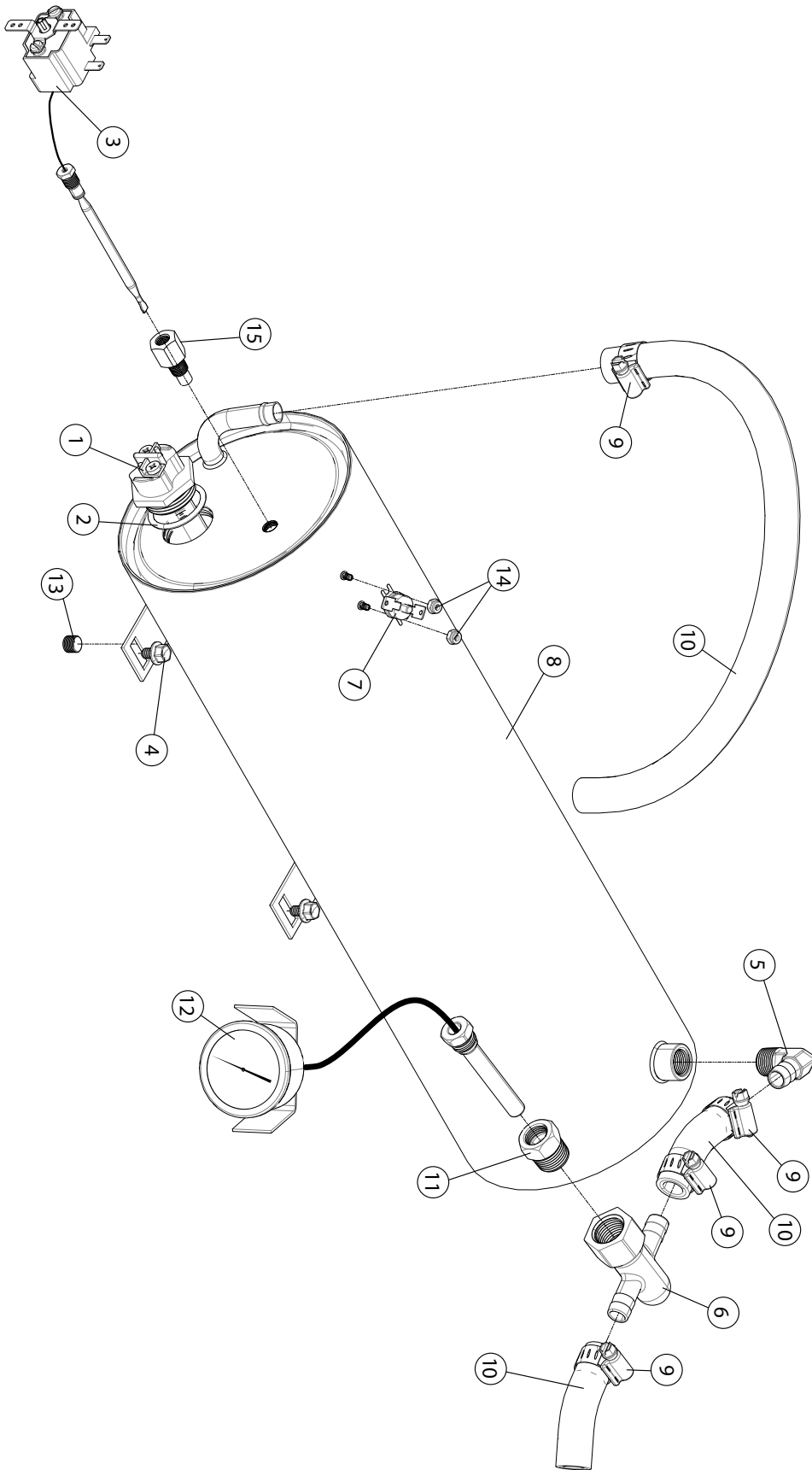

Item No.	Part No.	Description	Qty.
1	02103.12	HEATER, BOOSTER 4kW, 208V, 40°F RISE (Does not include gasket)	1
1	02103.13*	HEATER, BOOSTER 6kW, 208V, 70°F RISE (Does not include gasket)	1
2	02103.14	GASKET, BOOSTER HEATER	1
3	02103.15	THERMOSTAT, CONTROL 195°F	1
4	02103.16	BOLT, HEX FLANGE, 1/4-20 X 3/8"	1
5	40012.10	ELBOW, 3/8" NPT X 1/2" HOSE	1
6	02103.23	TEE, RINSE THERMOMETER	1
7	02103.19	THERMOSTAT, HI-LIMIT FIXED SNAP 240°F	1
8	02106.01	TANK, BOOSTER WELDMENT	1
9	02103.21	CLAMP, GEAR-TYPE, 7/16"	3
10	02103.22	HOSE, 1/2" ID	A/R
11	02103.24	FITTING, BOOSTER THERMOMETER	1
12	02103.25	THERMOMETER, 2" DIAL, 7' CAPILLARY	1
13	03232.00	PLUG, 1/8"	2
14	00965.00	NUT, 6-32 W/NYLON INSERT	2
15	2106.30	ADAPTER, BOOSTER TANK M9 X 1 TO 1/8"	1

\* When the 6kW element is used the minimum supply circuit Ampacity and Overcurrent protection will need to increase to use a 40 Amp Breaker.

Power Wiring Box

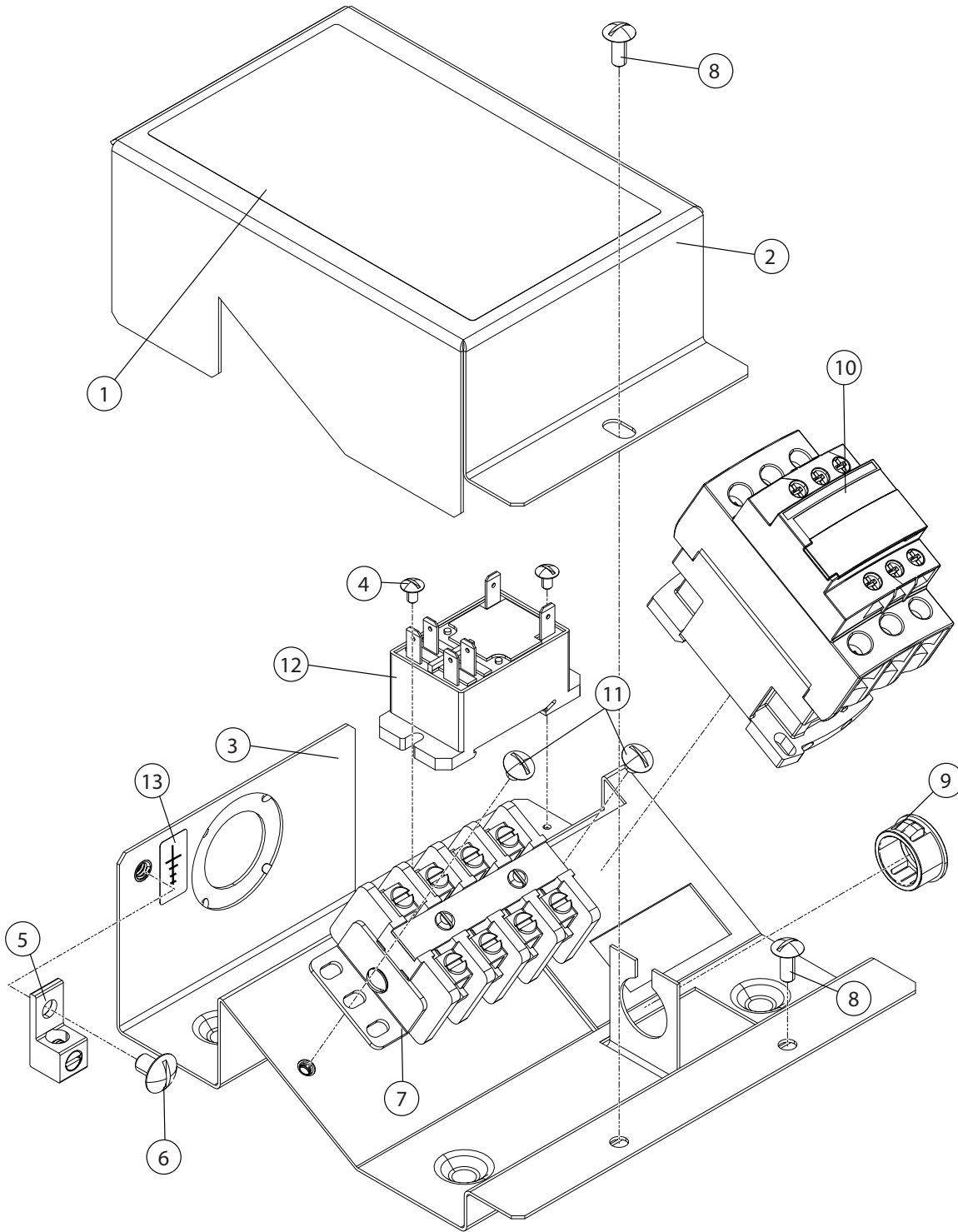

Item No.	Part No.	Description	Qty.
1	<a href="#">02106.02</a>	LABEL, CONNECTION BOX	1
2	02106.03	COVER, BOX WIRING	1
3	02106.04	BOX, WIRING	1
4	<a href="#">00421.51</a>	SCREW, 6-32 X 1/4"	2
5	<a href="#">13426.50</a>	LUG, GROUND	1
6	00905.82	SCREW, 1/4-20 X 3/8"	1
7	02106.05	BLOCK, TERMINAL, 4-POLE	1
8	<a href="#">00940.50</a>	SCREW, 10-32 X 3/8", TRUSS HEAD.	2
9	02106.15	BUSHING, STRAIN RELIEF, SMALL	A/R
10	<a href="#">02103.48</a>	CONTACTOR, 3-POLE , 25/40A, 120VAC COIL	1
11	00940.00	SCREW, 10-32 X 1/4"	2
12	<a href="#">02106.06</a>	RELAY, DPDT, 30A, 120VAC COIL	1
13	06202.46	LABEL, GROUND	1

# Electrical Panel and Timer

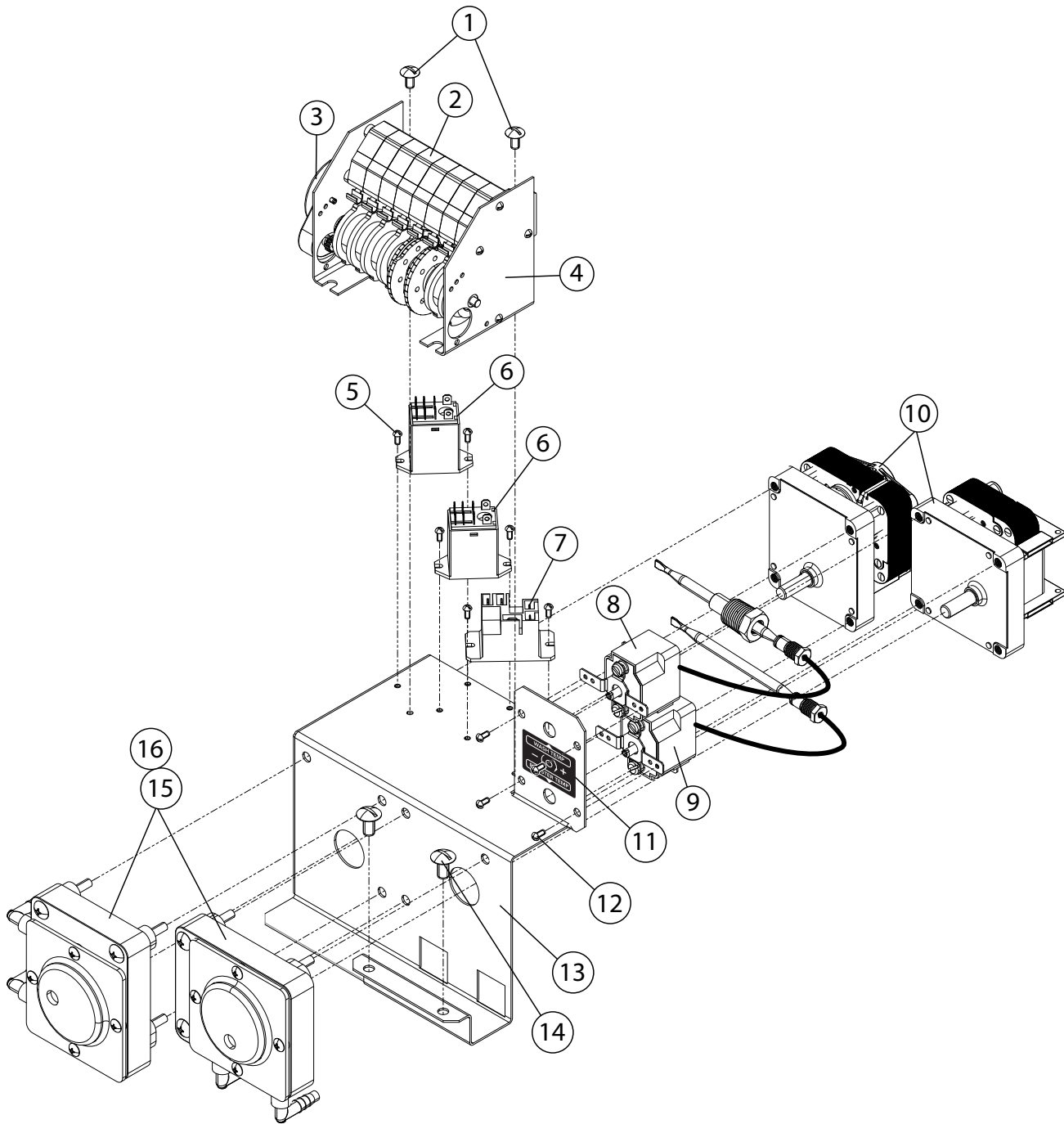

<b>Item No.</b>	<b>Part No.</b>	<b>Description</b>	<b>Qty.</b>
1	02103.93	SCREW, TRUSS HEAD, 8-32 X 1/4"	2
2	00411.00	SWITCH, TIMER	8
3	00501.00	MOTOR, TIMER	1
4	00408.60	ASSEMBLY, TIMER (Includes Items 2, 3)	1
5	00907.00	SCREW, 6-32 X 1/2"	6
6	02103.40	RELAY, 15 AMP, 120VAC COIL	2
7	00631.00	RELAY, 120VAC, 2PDT	1
8	43030.00	THERMOSTAT, WASH	1
9	02103.15	THERMOSTAT, BOOSTER 195°F	1
10	00416.00	MOTOR, PERI-PUMP 115VAC	2
11	02106.07	LABEL, WASH-RINSE TEMPERATURE	1
12	00907.50	SCREW, 6-32 X 3/8" PAN HEAD PHIL.	4
13	02106.08	BRACKET	1
14	00940.50	SCREW, 10-32 X 3/8", TRUSS HEAD.	2
15	00415.00	ASSY. PERI-PUMP (Includes Item 16 & 10)	2
16	02257.00	TUBE, SQUEEZE 8"	2

# Control Panel

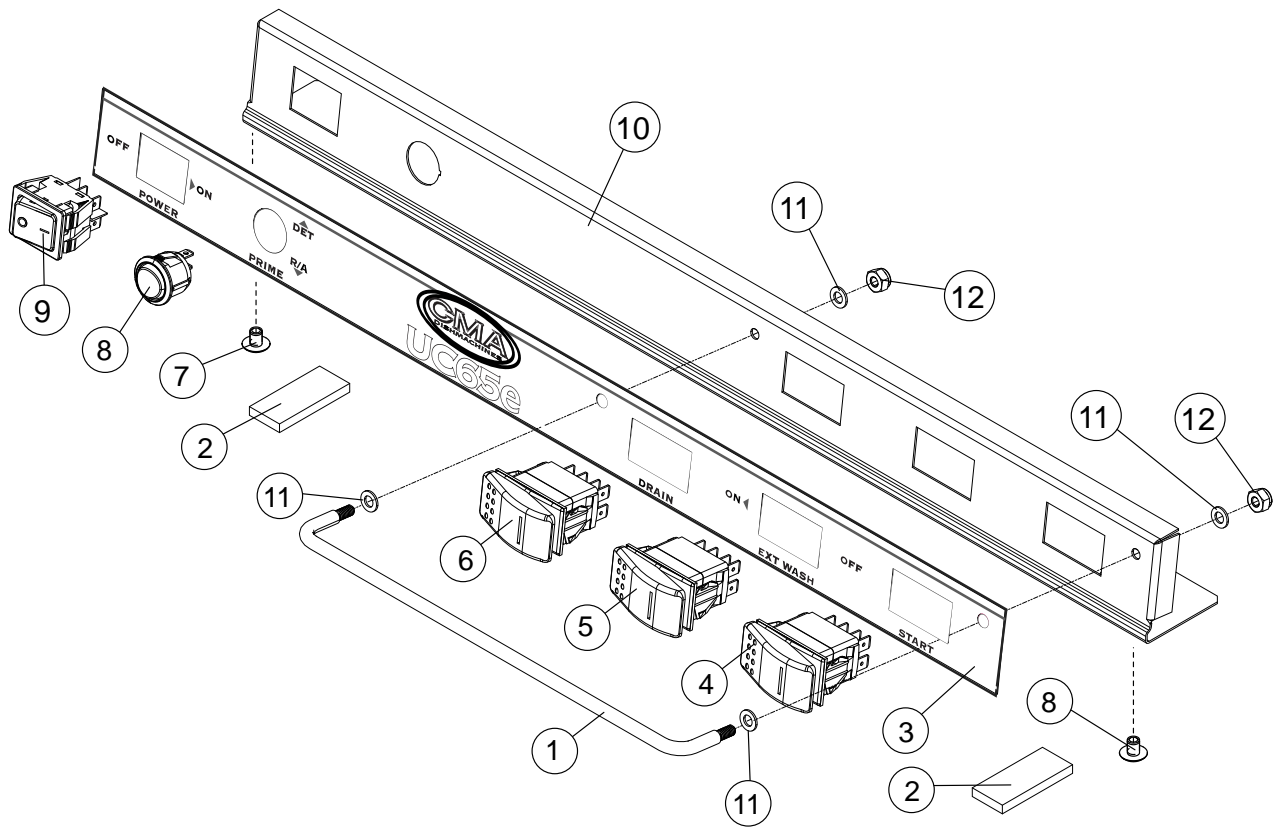

Item No.	Part No.	Description	Qty.
1	03485.00	GUARD, SWITCH (Includes items 11 & 12)	1
2	02103.58	GASKET, STEAM	2
3	02106.09	LABEL, FACIA, UC65e M2	1
4	15523.00	SWITCH, ROCKER, START MOMENTARY	1
5	15524.00	SWITCH, ROCKER, MAINTAINED	1
6	15523.50	SWITCH, ROCKER, DRAIN/FILL	1
7	00911.10	SCREW, TRUSS SLOT, 8-32 X 3/8"	2
8	02103.57	SWITCH, MOMENTARY (PRIME)	1
9	02103.50	SWITCH, ON-OFF	1
10	02106.10	PANEL, FACIA, UC65e M2	1
11	04086.00	#10 WASHER	4
12	03801.00	10-32 LOCK NUT	2

# Upper Final Rinse Piping

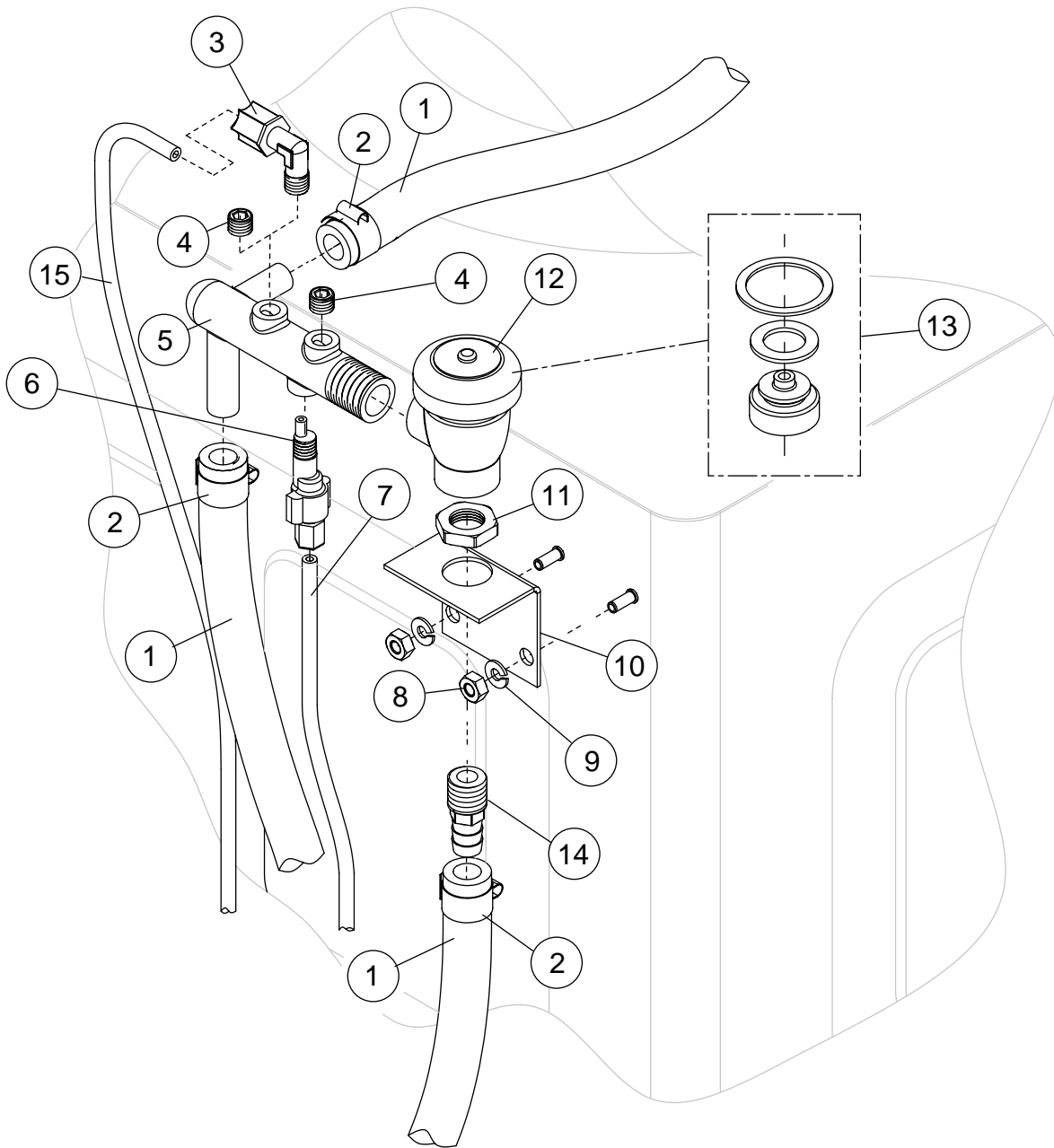

Item No.	Part No.	Description	Qty.
1	03107.50	HOSE, RUBBER 1/2ID X .84OD	A/R
2	03101.47	CLAMP, GEAR	6
3	02103.62	FITT COMP 1/4OD X 1/8MPT ELL J	1
4	03232.00	PLUG, 1/8 HEX COUNTERSUNK	1
5	02103.64	MANIFOLD, RINSE	1
6	02103.65	INJECTOR FITTING	1
7	00425.54	TUBING, 1/4" NATURAL	A/R
8	00923.50	NUT, KEP 1/4-20	2
9	02103.04	WASHER, SPLIT LOCK 1/4i 304SS	2
10	02103.69	BRACKET, VACUUM BREAKER	1
11	00721.00	NUT, JAMB 1/2"	1
12	02103.71	VACUUM BREAKER, 1/2" BRASS	1
13	02103.72	REPAIR KIT, VACUUM BREAKER 1/2"	1
14	40014.00	COUPLER 1/2 MPT X 1/2" HOSE	1

## Wash and Rinse Spray Arms

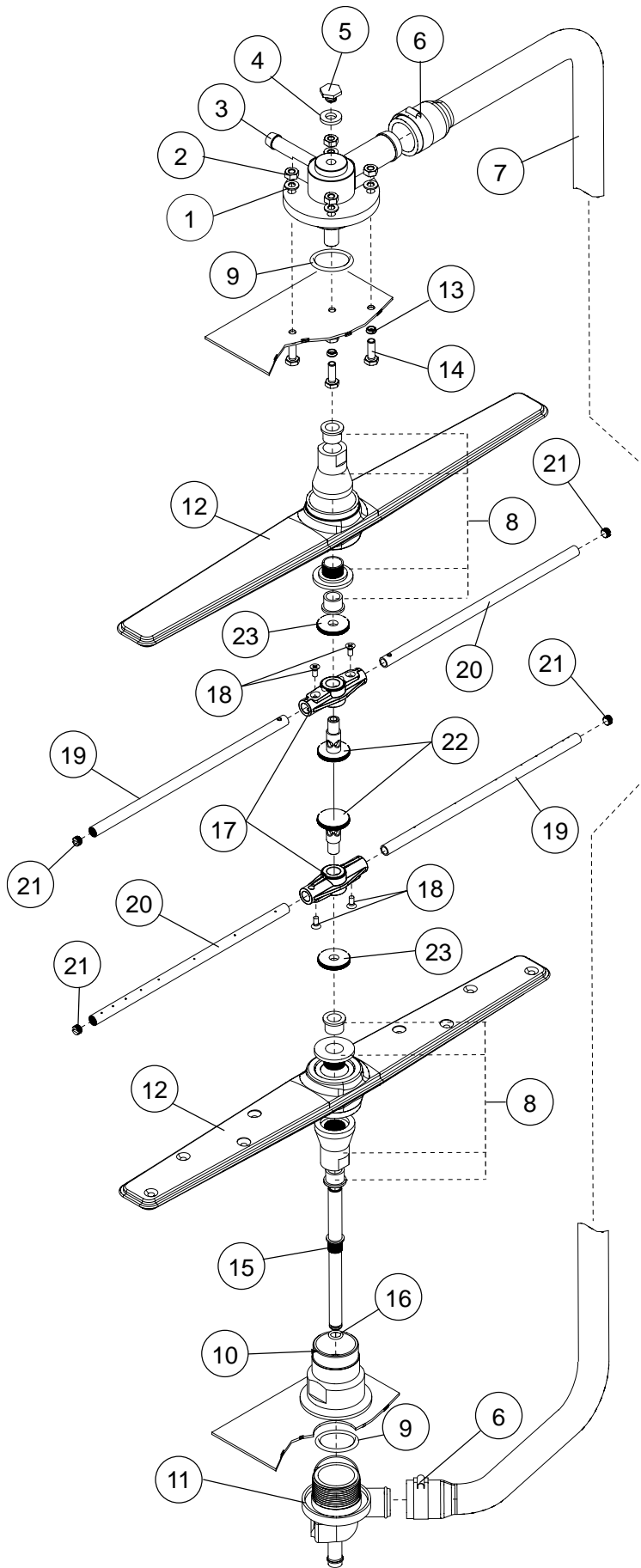

<b>Item No.</b>	<b>Part No.</b>	<b>Description</b>	<b>Qty.</b>
1	00426.00	WASHER, 5/16" SS WASHER	4
2	00912.00	NUT, 1/40-20 NYLON LOCK NUT	4
3	02103.77	HUB, UPPER WASH ARM	1
4	02103.78	WASHER, PACKING	1
5	02103.79	SCREW, RETAINING	1
6	50109.00	CLAMP, HOSE #28	2
7	02103.81	HOSE, UPPER WASH ARM	1
8*	02103.82	BEARING ASSEMBLY	2
9	02103.83	O-RING, 2-1/8" OD X 1-3/4" ID X 3/16"	2
10	02103.84	HUB, LOWER WASH ARM	1
11	02103.85	MANIFOLD, LOWER FWR	1
12	02103.86	WASH ARM ASSEMBLY (Includes Item 8)	2
13	02103.88	WASHER, NYLITE	4
14	02103.89	BOLT, 1/4-20 X 1"	4
15	02103.90	SHAFT, LOWER	1
16	02103.91	O-RING	1
17	02103.92	HUB, RINSE ARM, MOLDED	2
18	02103.93	SCREW, TRUSS HEAD 8-32 X 1/4"	4
19	02103.94	ARM, RIGHT-HAND RINSE (7 JETS)	2
20	02103.95	ARM, LEFT-HAND RINSE (8 JETS)	2
21	02103.96	CAP, RINSE ARM, 5/16-24	4
22	02103.97	SPINDLE, RINSE ARM	2
23	02103.98	SPACER, NUT	2
---	02103.99	RINSE ARM ASSEMBLY (Includes Items 18-23)	2

*\* Note:*

*The bearing assembly, P/N 2103.82 includes 2 bearings, 1 locknut, and 1 wash arm hub. The bearings, locknut and hub are not available as separate service replacement parts.*

# Drain Pump and Hoses

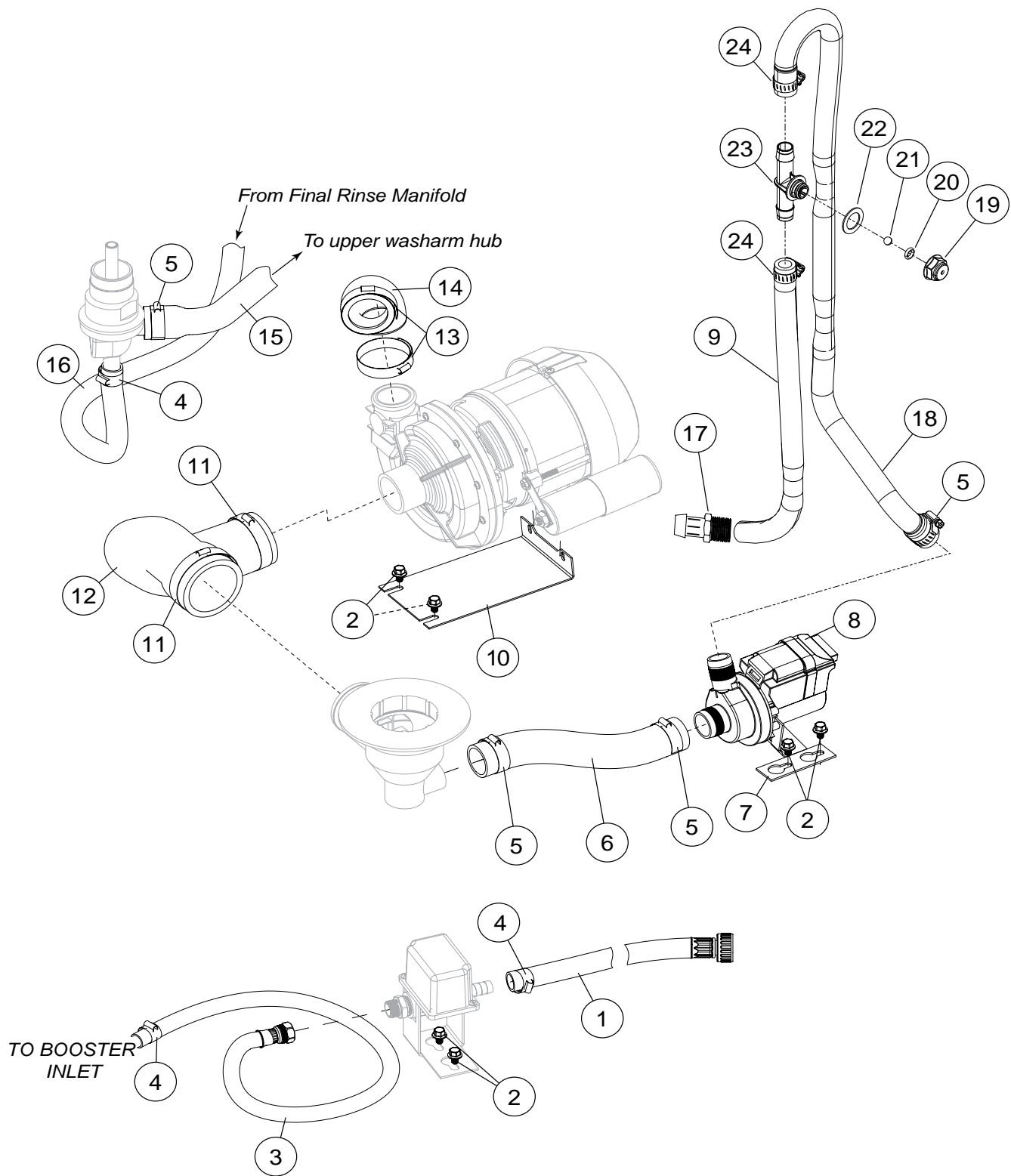

<b>Item No.</b>	<b>Part No.</b>	<b>Description</b>	<b>Qty.</b>
1	02104.00	HOSE, FILL 1/2" X 7' C/W 3/4" FNPS	1
2	02103.16	BOLT, HEX FLANGE, 1/4-20 X 3/8"	4
3	02103.18	HOSE, BOOSTER FILL, 1/2" X 1'	1
4	03101.47	CLAMP, HOSE GEAR-TYPE 5/16"	3
5	03101.00	CLAMP, HOSE GEAR-TYPE, 1"	3
6	02104.05	HOSE, DRAIN PUMP SUCTION	1
7	02104.06	BRACKET, DRAIN PUMP	1
8	02104.07	PUMP, DRAIN 115VAC	1
9	02104.84	HOSE, DRAIN	1
10	02104.09	BRACKET, WASH PUMP	1
11	02104.10	CLAMP, HOSE GEAR-TYPE 1-13/16"- 2-3/4" MAX	2
12	02104.11	HOSE, SUCTION WASH PUMP	1
13	50109.00	CLAMP, HOSE #28	2
14	02104.13	HOSE, DISCHARGE WASH PUMP	1
15	02103.81	HOSE, UPPER WASH ARM	1
16	03107.50	HOSE RUBBER, 1/2" ID X .84" OD	A/R
17*	02103.68	COUPLER, 3/4" MPT X 3/4" HOSE BARB	1
18	02106.19	HOSE, DRAIN MOLDED	1
19	02106.21	NUT, ANTI-SIPHON VALVE	1
20	02106.23	O-RING	1
21	02106.25	BALL, 3/8" DIAMETER, STAINLESS STEEL	1
22	02106.27	WASHER, SILICONE	1
23	02106.17	BODY, ANTI-SIPHON	1
24	02103.21	CLAMP, HOSE GEAR-TYPE, STAINLESS STEEL	2

**\* NOTE:**

ITEM 17 IS STRAPPED TO THE DRAIN HOSE AS A SEPARATE PART FOR THE PLUMBING INSTALLER TO USE DURING INSTALLATION.

# Wash Tank Heater and Drain

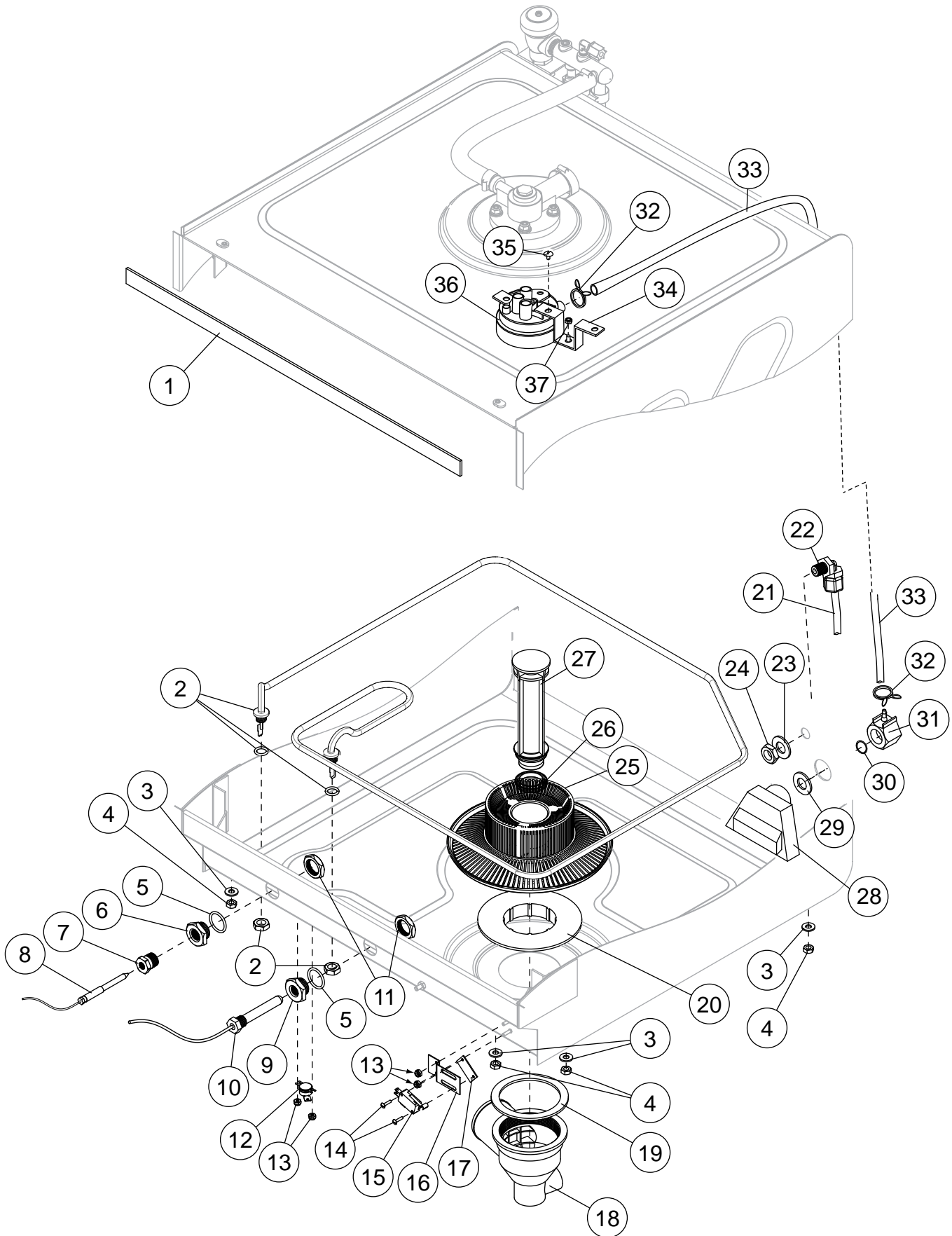

Item No.	Part No.	Description	Qty.
1	02104.17	GASKET, DOOR	1
2	02104.18	HEATER, WASH TANK, 2KW, 240VAC	1
3	00968.00	WASHER, SPLIT LOCK 1/4"	4
4	00923.50	NUT, HEX 1/4-20	4
5	02104.21	O-RING	2
6	02104.22	ADAPTER, THERMOSTAT	1
7	02103.28	BUSHING, THERMOSTAT	1
8	43030.00	THERMOSTAT, WASH TANK	1
9	02104.25	ADAPTER, THERMOMETER	1
10	02103.25	THERMOMETER, 2" DIAL 7' CAPILLARY	1
11	00721.00	NUT, JAMB 1/2" THIN PATTERN	2
12	02104.28	THERMOSTAT, FIXED, SNAP 212°F	1
13	00965.00	NUT, LOCK 6-32 W/NYLON INSERT	4
14	13826.00	SCREW, 4-40 X 5/8" PAN HEAD	2
15	43019.00	SWITCH, DOOR 15 AMP	1
16	02104.32	BRACKET, SWITCH	1
17	02104.33	PLATE, SWITCH NUT	1
18	02104.34	ELBOW, PUMP SUCTION	1
19	02104.35	GASKET, PUMP SUCTION	1
20	02104.36	FLANGE, PUMP SUCTION	1
21	02104.37	HOSE, 1/4" ID X 3/8" OD	A/R
22	02104.38	ELBOW, 3/8" TUBE X 1/4" NPT	1
23	02104.39	GASKET, 1/4" FIBER	1
24	02104.40	LOCKNUT, 1/4" PLASTIC	1
25	02104.41	FILTER, SUMP	1
26	02100.57	FILTER, O-RING	1
27	02104.43	TUBE, OVERFLOW	1
28	02104.53	TRAP, AIR	1
29	02104.55	GASKET, AIR TRAP	1
30	02104.57	ORING, NUT, AIR TRAP	1
31	02104.59	NUT, AIR TRAP	1
32	02104.54	CLAMP, HOSE AIR	2
33	02104.56	HOSE, AIR	4FT.
34	02104.90	BRACKET	1
35	02104.91	SCREW, 6-18 X 1/4" PAN HEAD. PHIL.	1
36	02104.92	SWITCH, PRESSURE	1
37	03801.60	NUT, LOCK, 10-32 KEPS	1

# Fill Solenoid Valve

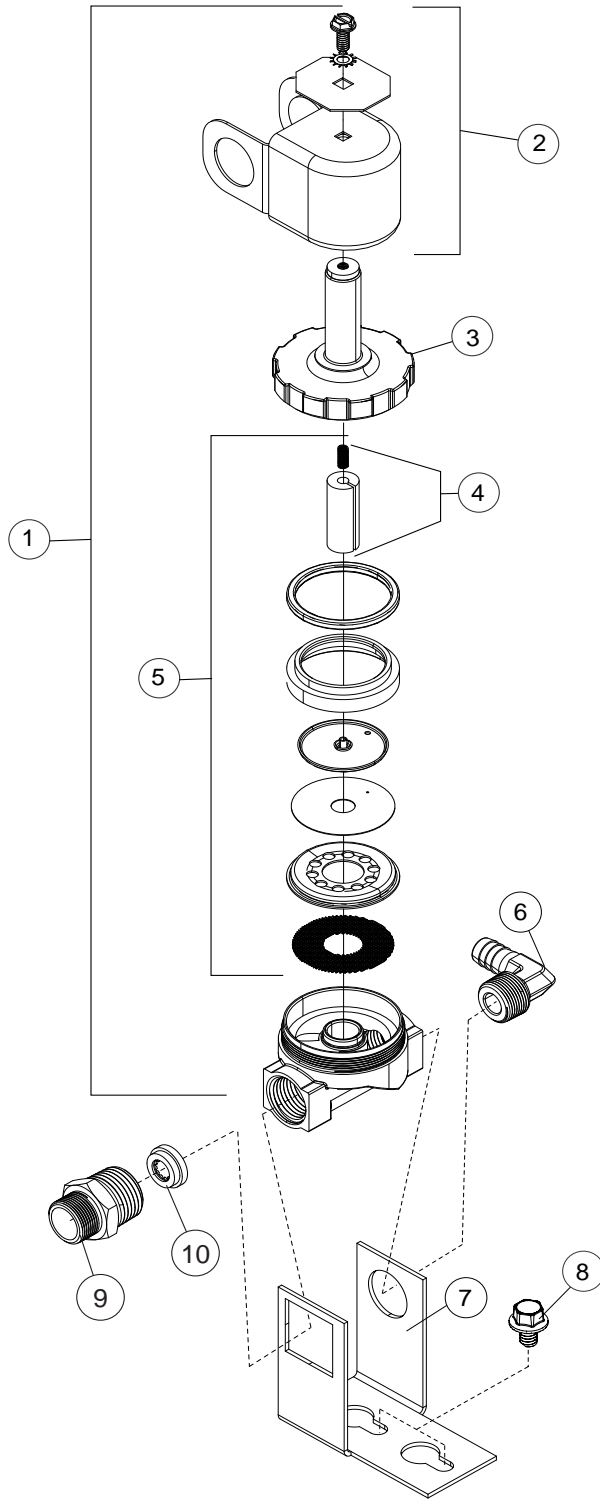

<b>Item No.</b>	<b>Part No.</b>	<b>Description</b>	<b>Qty.</b>
1	03603.10	WATER SOLENOID 1/2" J/E COMPLETE (Includes Items 2-6)	1
2	00738.10	WATER SOLENOID COIL J/E	1
3	03603.20	1/2" WATER SOLENOID BONNET	1
4	00786.00	WATER SOLENOID VALVE PLUNGER	1
5	00707.00	1/2" WATER SOLENOID REPAIR KIT	1
6	40013.00	FITTING, BARB HOSE	1
7	02106.11	BRACKET, VALVE, UC65E	1
8	02103.16	BOLT, HEX FLANGE 1/4-20 X 3/8"	2
9	03604.50	FITTING, FLOW DISC, DEMA	1
10	03604.10	WASHER, FLOW	1

# Detergent Pump

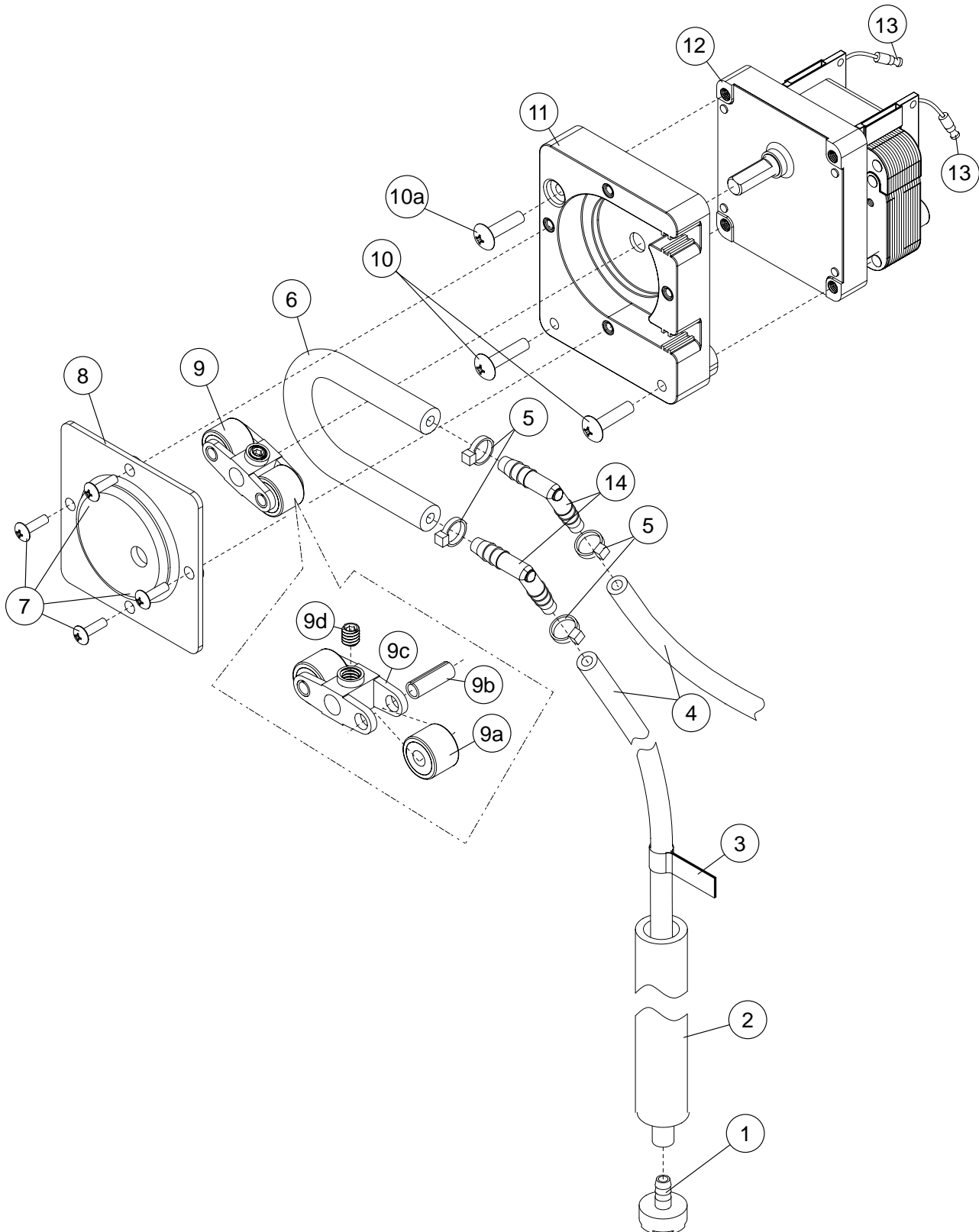

Item No.	Part No.	Description	Qty.
1	02104.47	STRAINER	1
2	02104.48	TUBE,STIFFENER, 1/2" ID X 11-7/8" LG.	1
3	43078.05	LABEL, DETERGENT	1
4	02104.37	HOSE, 1/4ID X 3/8OD PVC	A/R
5	02104.51	TIE, NYLON 4"	4
6	02257.00	TUBE, SQUEEZE 8"	1
7	00911.00	SCREW, 8-32 X 1/2" PANHEAD	4
8	00418.00	COVER, PUMP	1
9	00419.00	ASSEMBLY, ROLLER	1
10	00919.00	SCREW, 10-32 X 1-1/2" PANHEAD	2
10a	00918.10	SCREW, 10-32 X 1-1/2" FLATHEAD	1
11	00417.10	BLOCK, PUMP	1
12	00416.00	MOTOR, PUMP 115VAC	1
13	00448.00	CONNECTOR, MALE BARREL	2
14	02104.52	ELBOW, 1/4" HOSE BARB	1
----	00415.00	ASSEMBLY, PERI-PUMP COMPLETE (Includes Items 6-13)	1

# Rinse-Aid Pump

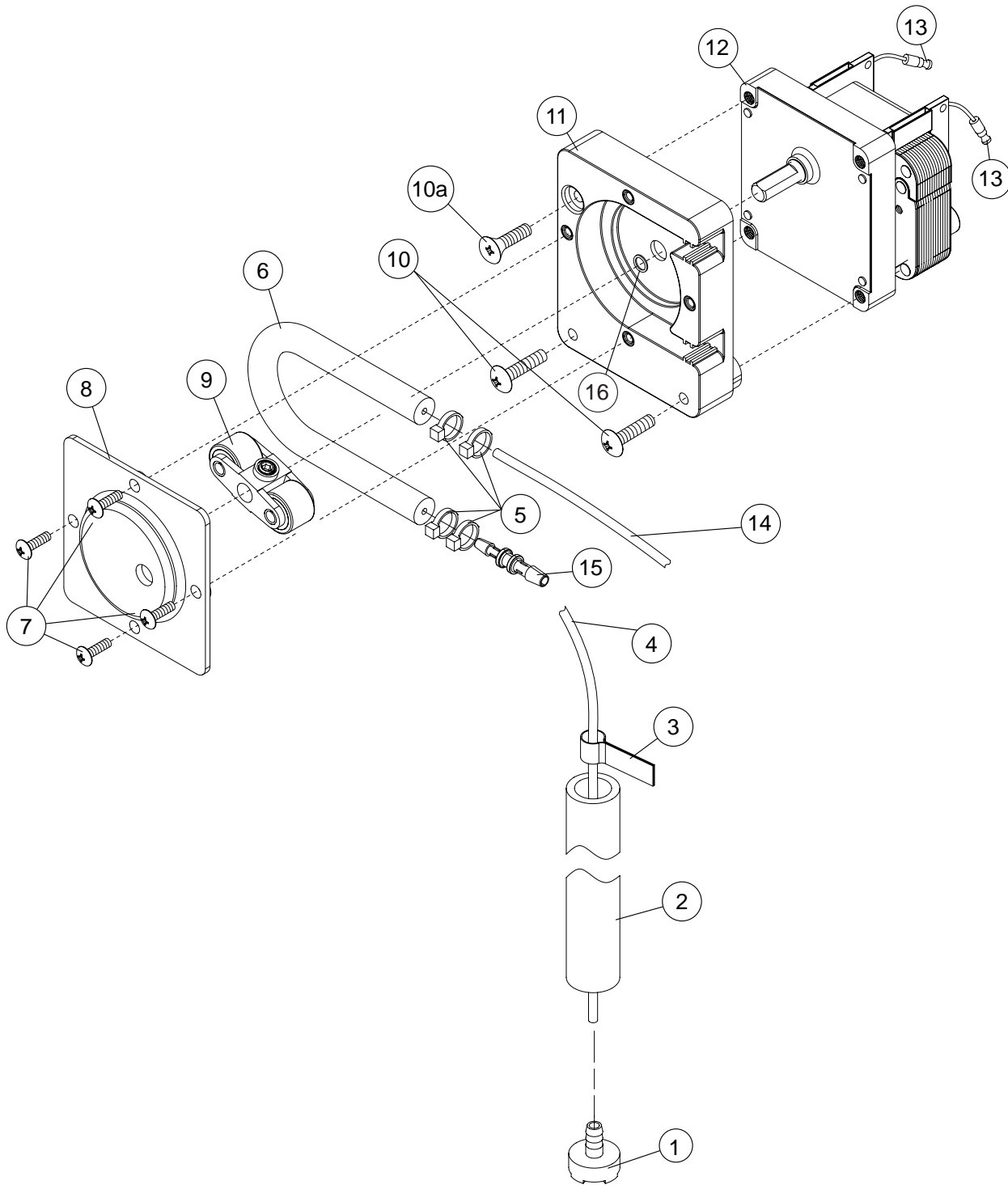

Item No.	Part No.	Description	Qty.
1	02104.47	STRAINER	1
2	02104.48	TUBE,STIFFENER, 1/2" ID X 11-7/8" LG.	1
3	40378.08	LABEL, RINSE AID	1
4	07237.00	TUBING, 1/8" ID X 1/4" OD	A/R
5	00931.00	TIE, CABLE 4-1/2"	4
6	02257.00	TUBE, SQUEEZE 8"	1
7	00911.00	SCREW, 8-32 X 1/2" PANHEAD	4
8	00418.00	COVER, PUMP	1
9	00419.00	ASSEMBLY, ROLLER	1
10	00919.00	SCREW, 10-32 X 1-1/2" PANHEAD	2
10a	00918.10	SCREW, 10-32 X 1-1/2" FLATHEAD	1
11	00417.10	BLOCK, PUMP	1
12	00416.00	MOTOR, PUMP 115VAC	1
13	00448.00	CONNECTOR, MALE BARREL	2
14	00425.54	TUBING, CHEMICAL 1/4" NATURAL	A/R
15	02106.12	CONNECTOR, 5/32" X 1/8"	1
----	00415.00	ASSEMBLY, PERI-PUMP COMPLETE (Includes Items 6-13)	1

# Panels

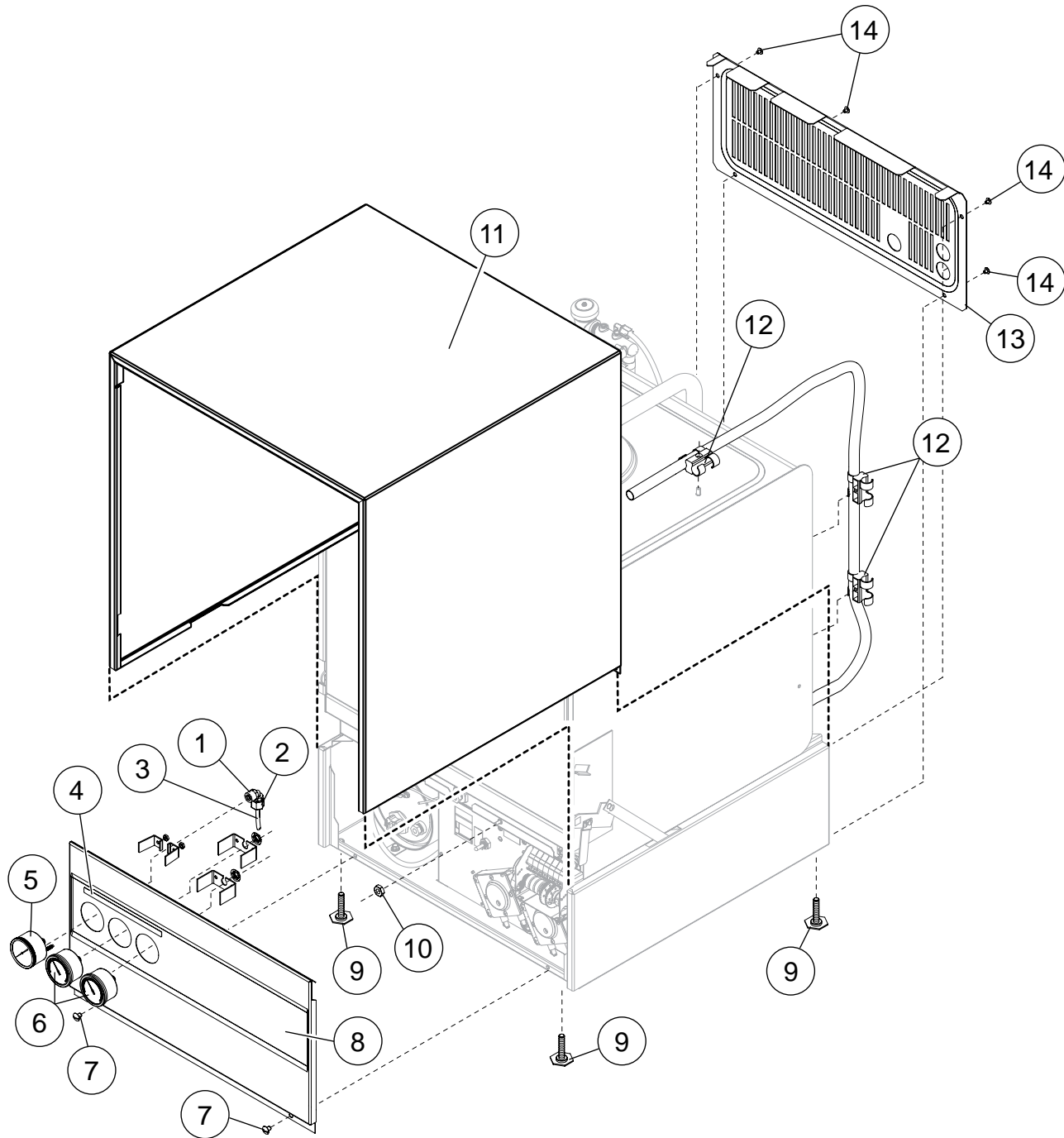

Item No.	Part No.	Description	Qty.
1	02103.62	FITTING, COMP 1/4" OD X 1/8 MPT ELL J	1
2	02104.60	ADAPTOR, 1/8" NPT X 1/4" TUBE	1
3	00425.54	TUBING, CHEMICAL 1/4" NATURAL	A/R
4	02104.62	LABEL, GAUGE	1
5	02104.63	GAUGE, PRESSURE 0-60PSI	1
6	02103.25	THERMOMETER, 2" DIAL, 7' CAPILLARY	2
7	00929.00	BOLT, 1/4-20 X 3/4" TRUSS HEAD	2
8	02104.66	PANEL, FRONT UC65e	1
9	02104.67	FOOT, ADJUSTING	4
10	02104.68	NUT, KEPS, 10-32	1
11	02104.69	WRAP, OUTER PANEL	1
12	02104.70	CLAMP, DOUBLE CONDUIT	3
13	02106.13	PANEL, REAR	1
14	02103.39	SCREW TRUSS HEAD 10-32 X 3/8"	4
15	02104.85	FRAME STAND	1

Door

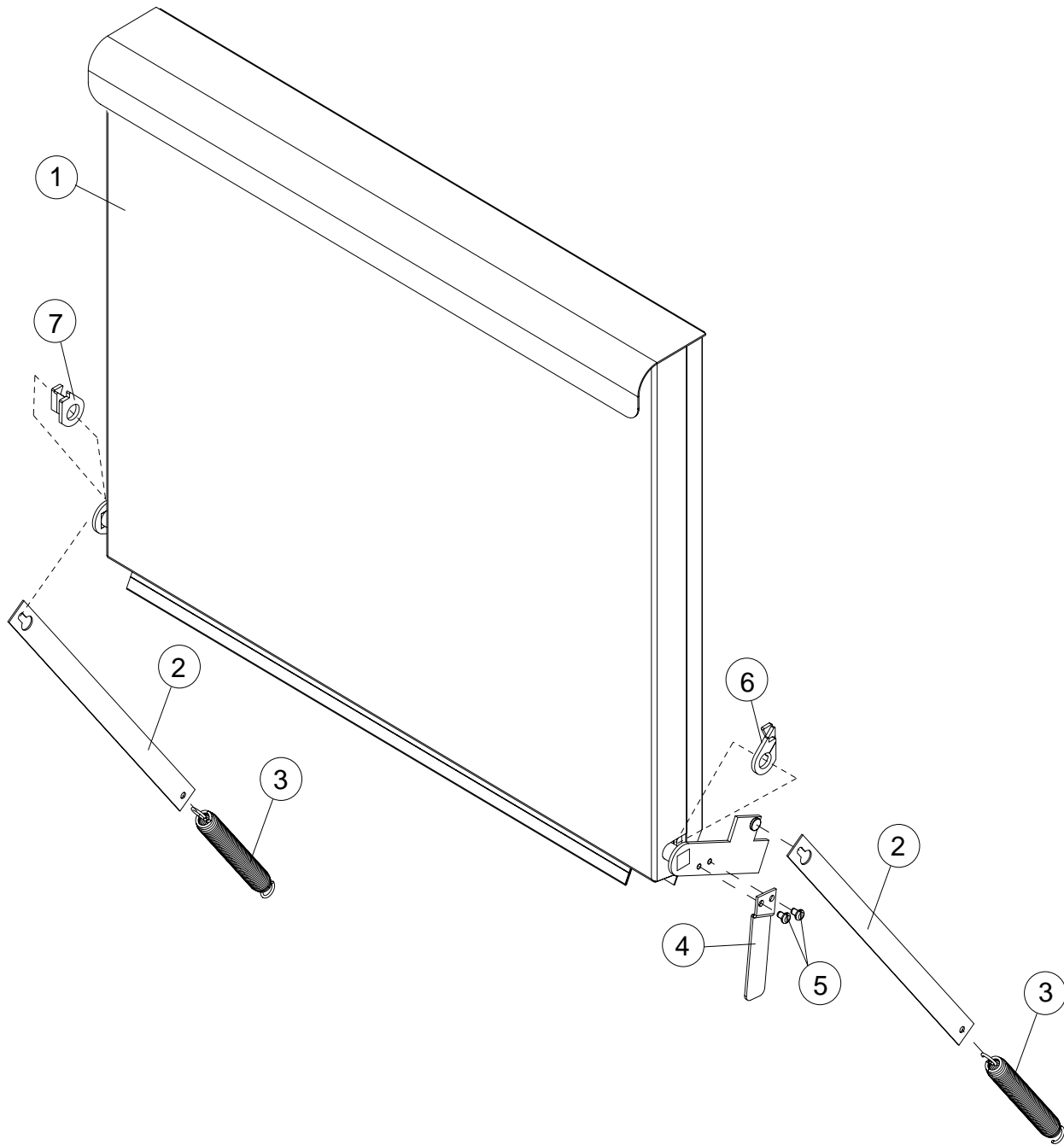

<b>Item No.</b>	<b>Part No.</b>	<b>Description</b>	<b>Qty.</b>
1	02104.73	DOOR WELDED ASSY	1
2	02104.76	ARM, DOOR SPRING	2
3	02104.77	SPRING, DOOR	2
4	02104.78	ACTUATOR, DOOR SWITCH	1
5	00911.10	SCREW, 8-32 X 3/8" TRUSS HEAD	2
6	02104.88	SEAL, DOOR HINGE, RH	1
7	02104.87	SEAL, DOOR HINGE, LH	1

**Dish Racks, Line Strainer**

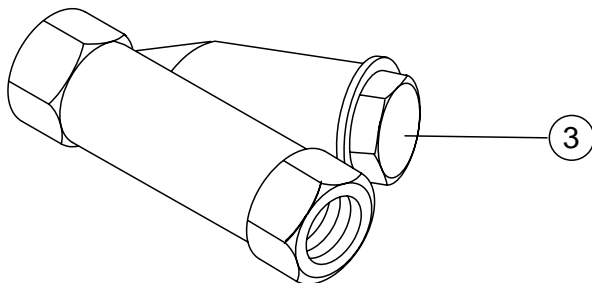
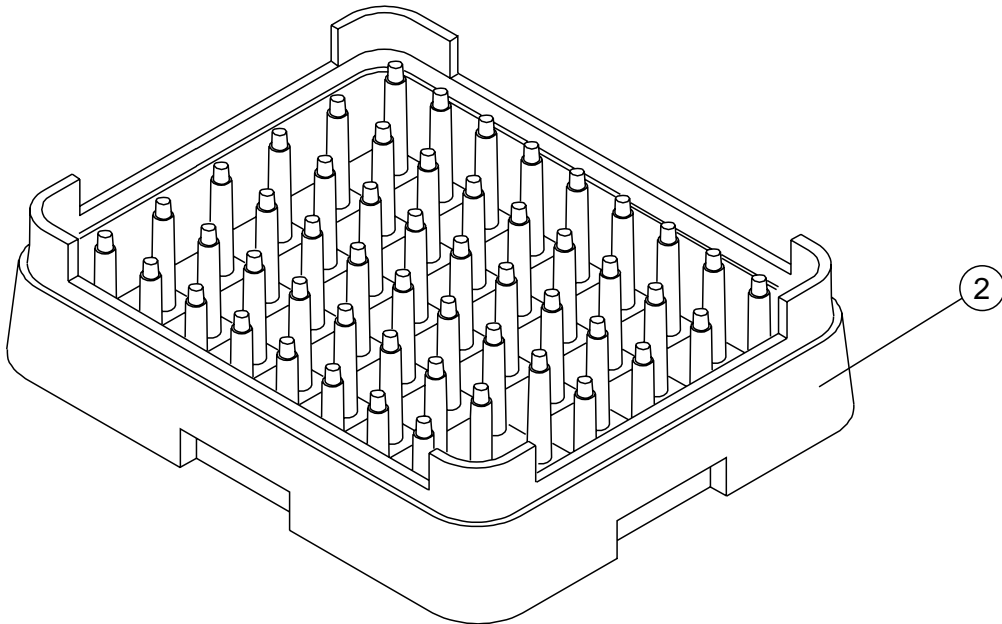
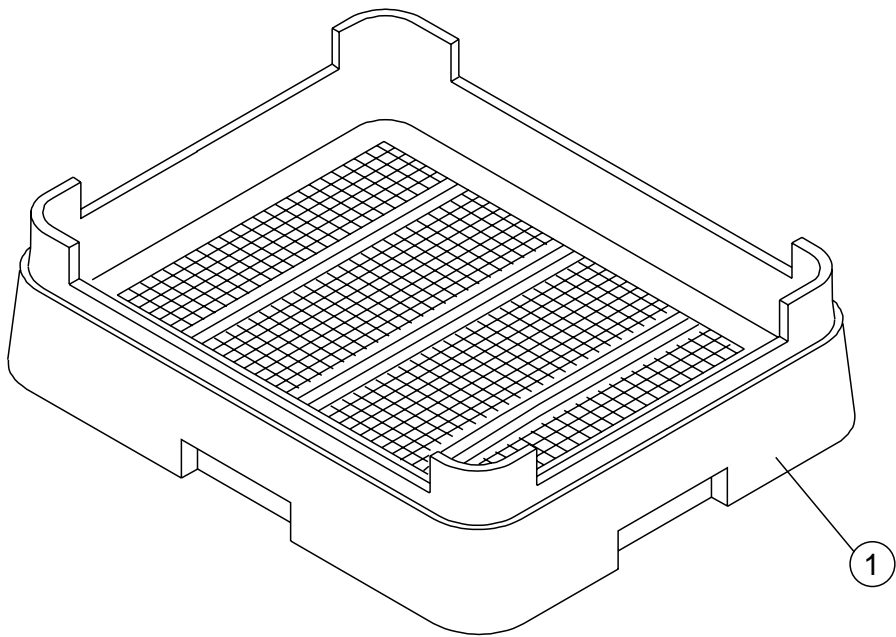

<b>Item No.</b>	<b>Part No.</b>	<b>Description</b>	<b>Qty.</b>
1	12960.01	DISH RACK, BOWL	A/R
2	12960.03	DISH RACK, PEG	A/R
3	03602.50	STRAINER, LINE 1/2" Y	1

# Electrical Schematic

TO CUSTOMERS DISCONNECT SWITCH  
PER LOCAL ELECTRICAL CODE  
115-208/230V/1PH 60HZ

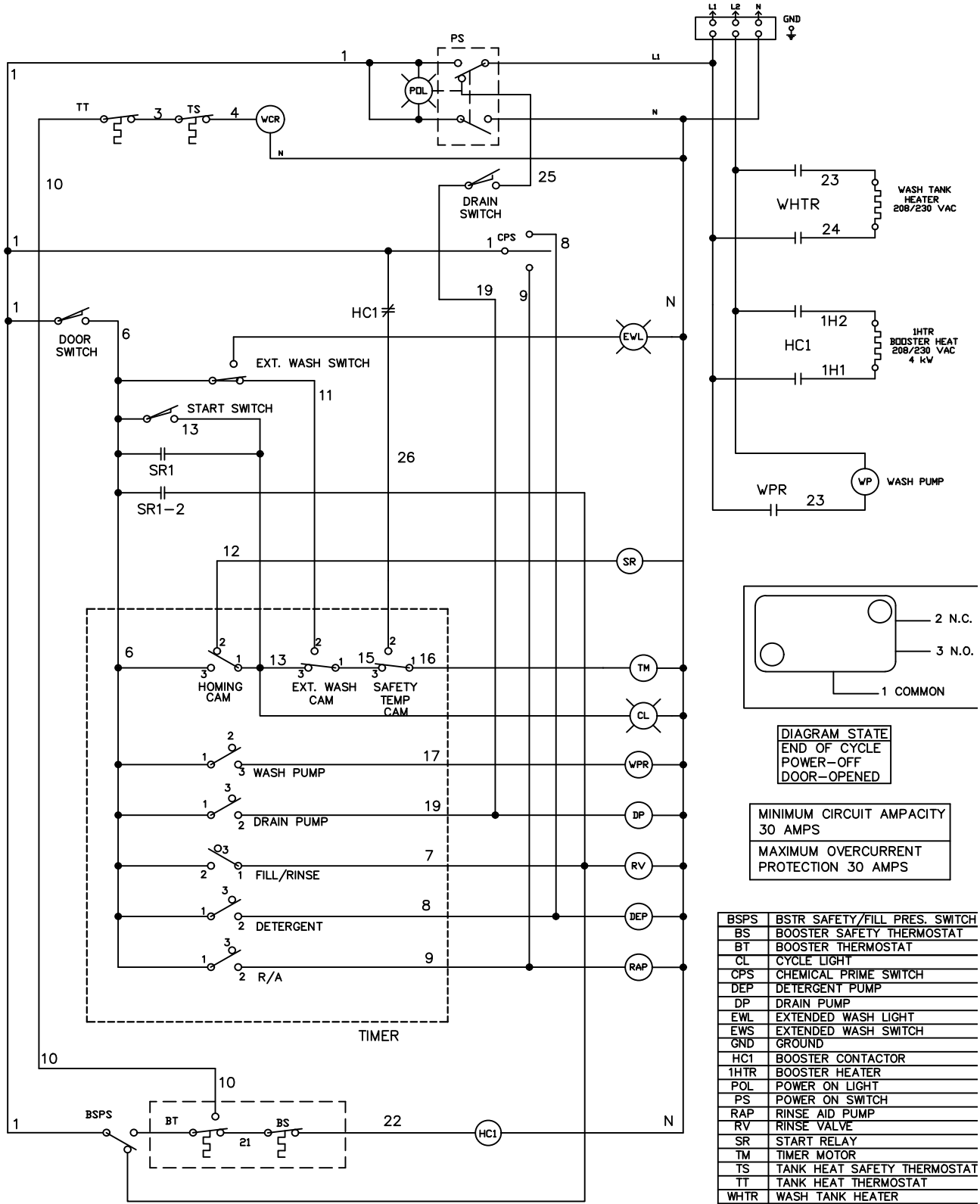

BSPTS	BSTR SAFETY/FILL PRES. SWITCH
BS	BOOSTER SAFETY THERMOSTAT
BT	BOOSTER THERMOSTAT
CL	CYCLE LIGHT
CPS	CHEMICAL PRIME SWITCH
DEP	DETERGENT PUMP
DP	DRAIN PUMP
EWL	EXTENDED WASH LIGHT
EWS	EXTENDED WASH SWITCH
GND	GROUND
HC1	BOOSTER CONTACTOR
1HTR	BOOSTER HEATER
1HTR	BOOSTER HEATER
POL	POWER ON LIGHT
PS	POWER ON SWITCH
RAP	RINSE AID PUMP
RV	RINSE VALVE
SR	START RELAY
TM	TIMER MOTOR
TS	TANK HEAT SAFETY THERMOSTAT
TT	TANK HEAT THERMOSTAT
WHTR	WASH TANK HEATER
WPR	WASH PUMP RELAY
WHR	WASH HEATER RELAY

HIGH TEMP UNDERCOUNTER

DATE | NUMBER/REV

TIMING CHART

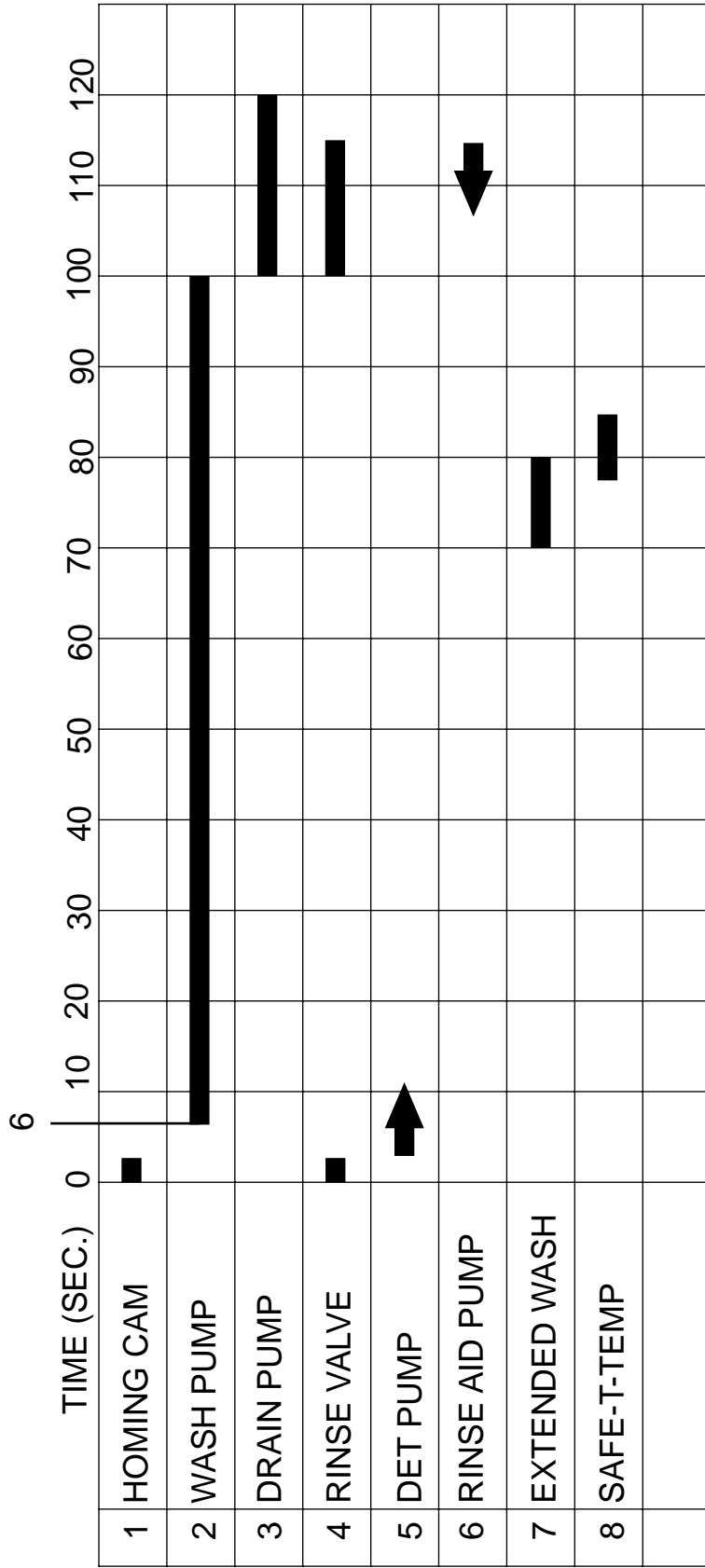

CMA Dishmachines

UC65e

DRAWING NO.  
05CTIME

***This Page  
Intentionally  
Left Blank***