



CMA Dishmachines
12700 Knott Avenue
Garden Grove, CA 92841

Toll Free: 1- (800) 854-6417
Fax: 1- (714) 895-2141

Service Replacement Parts



Undercounter High Temperature Dishwasher

Models:

UC65e



Machine Serial No.



Issue Date: 2.21.14

Manual P/N 0512865 rev. D

For machines beginning with S/N W090217876 and above

CMA Dishmachines
12700 Knott Avenue
Garden Grove, CA 92841
Toll Free: 1 (800) 854-6417
Fax: 1 (714) 895-2141

Printed in the USA



For future reference, record your dishwasher information in the box below.

Model Number _____	Serial Number _____
Voltage _____ Hertz _____	Phase _____
Service Agent _____	Tel: _____
Parts Distributor _____	Tel: _____

National Service Department

CMA Dishmachines
12700 Knott Avenue
Garden Grove, CA 92841
Toll-free: 1 (800) 854-6417
Fax: 1 (714) 895-2141

ATTENTION:

The model no., serial no., voltage, Hz and phase are needed to identify your machine and to answer questions.

The machine data plate is located on the lower front panel.

Please have this information ready if you call for service assistance.

Revision History

- The Revision History can contain part number changes, new instructions, or information that was not available at print time.
- We reserve the right to make changes to these instructions without notice and without incurring any liability by making the changes..
- Equipment owners may request a revised manual, at no charge, by calling CMA Dishmachines at 1 (800) 854-6417.

Revision Date	Revised Pages	Serial Number Effectivity	Revision Description
6.04.09	All	W090217876	Released First Edition
3.15.11	22-23	W090217876	Added motor fan cover to parts list
1.04.11	31 33 35	W090217876	Item 5 changed to P/N 0513110 Item 6 changed to P/N 0512120 Item 18 changed to P/N 0312840 Item 13 changed to P/N 0512855
6.09.11	44-45 46-47	W090217876 W090217876	Item 13 changed to P/N 0312924 Changed door assembly to P/N 0713141
4.19.13	5 24-55 26-27 30-31 34-35 46-47	All W120631743 W120631743 All W120631743 All All	Added hose barb to instructions Revised pressure gauge piping Added P/N 109069 thermostat Revised fill/drain timer, P/N 0713133 Revised pressure gauge piping Added hose barb P/N 0512231 Added Door drip seals, P/N 0512953 and P/N 0512954
6.25.13	53-62 2-3	All All	Added parts installation instructions Added hard wiring info to installation
11.18.13	All	All	Converted 0xxxxxx P/N's to CMA standards

Model Description

UC65e

High temperature hot water sanitizing dishwasher with built-in 40°F/22°C rise booster heater.
208-240VAC/60/1

Table of Contents

Model UC65e Undercounter Dishwasher

<i>Revision History</i>	<i>i</i>
<i>Model Descriptions</i>	<i>ii</i>
Service Replacement Parts	1

***This Page
Intentionally
Left Blank***

Service Replacement Parts

Illustrations	Page
Wash Pump/Motor Assembly	2
Booster Assembly.....	4
Electrical Panel and Timer Assembly	6
Control Panel Assembly	8
Upper Final Rinse Piping Assembly	10
Wash and Rinse Spray Arm Assemblies	12
Drain Pump and Lower Hose Assemblies	14
Wash Tank Heater and Drain Assemblies	16
Fill Solenoid Valve Assembly.....	18
Detergent Pump Assembly.....	20
Rinse-aid Pump Assembly.....	22
Panel Assembly.....	24
Door Assembly	26
Dish racks, Line Strainer and Pressure Regulating Vavle (PRV)	28

Wash Pump/Motor Assembly

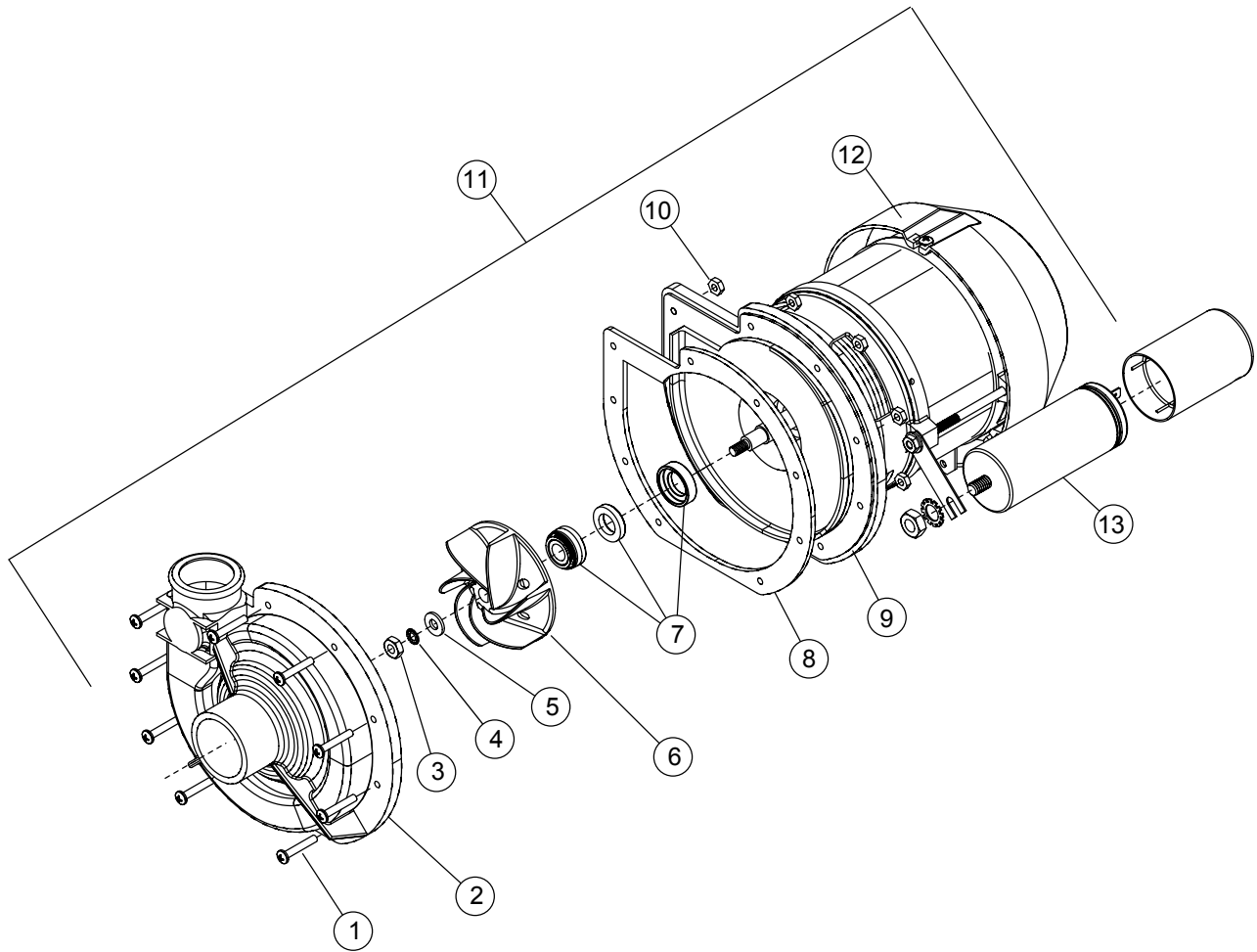

Item No.	Part No.	Description	Qty.
1	2103.01	SCREW, M4, PHIL, PAN HD.	9
2	2103.02	IMPELLER HOUSING COVER	1
3	2103.03	NUT, M6 (left-hand threads)	1
4	2103.04	WASHER, LOCK, 1/4"	1
5	2103.05	WASHER, PLAIN, M6	1
6	2103.06	IMPELLER	1
7	2103.07	SEAL	1
8	2103.30	GASKET, PUMP	1
9	2103.09	BACKPLATE, PUMP	1
10	2103.08	NUT, M4	9
11	2103.10	PUMP/MOTOR ASSEMBLY COMPLETE 220VAC/60/1	1
12	2103.37	COVER, REAR MOTOR FAN	1
13	2103.11	CAPACITOR 16 μ F	1

Booster Assembly

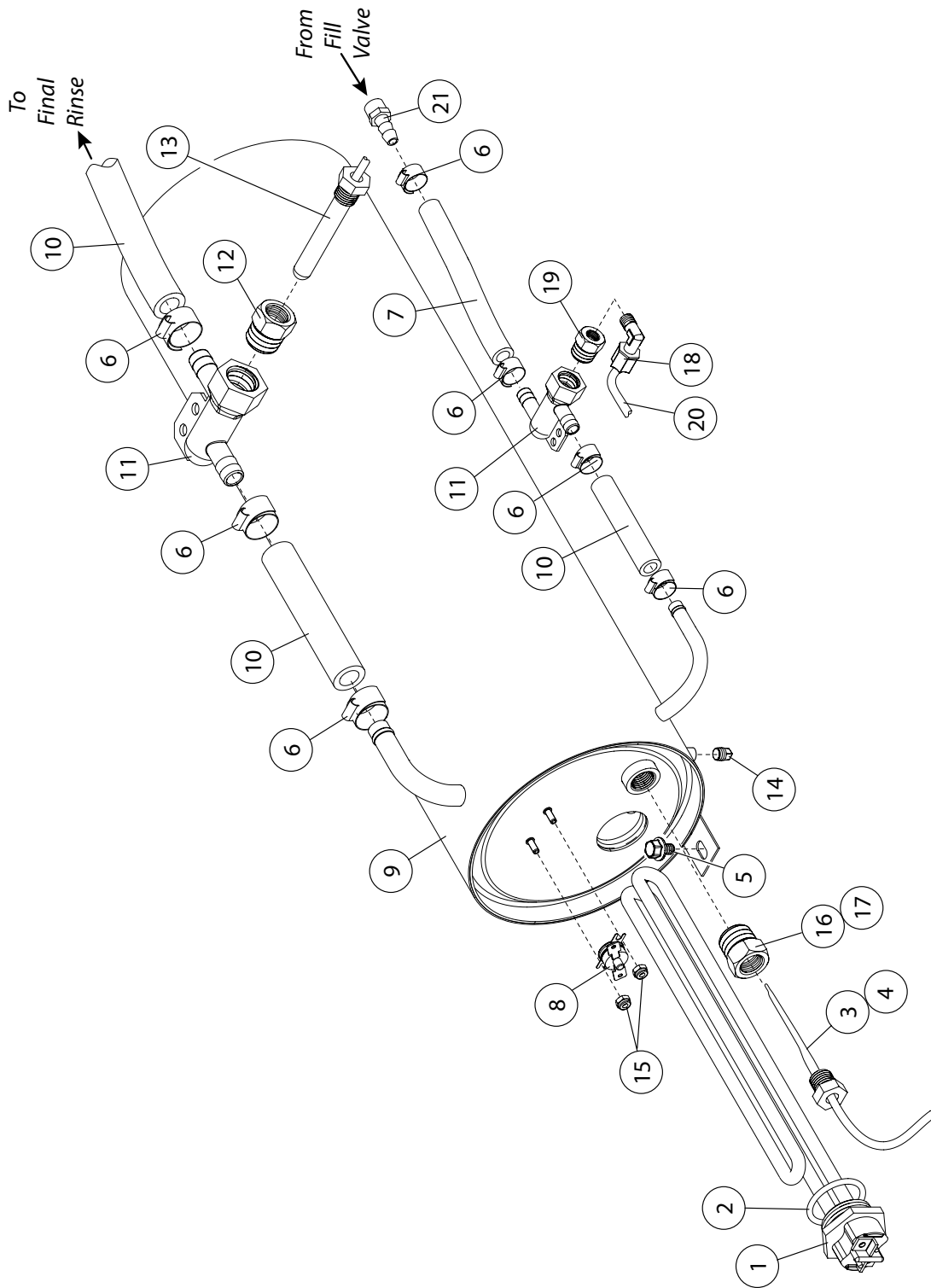

Item No.	Part No.	Description	Qty.
1	2103.12	HEATER, BOOSTER 4kW, 208V, 40°F RISE <i>(Does not include gasket)</i>	1
1	2103.13	HEATER, BOOSTER 6kW, 208V, 70°F RISE <i>(Does not include gasket)</i>	1
2	2103.14	GASKET, BOOSTER HEATER	1
3	2103.15	THERMOSTAT, CONTROL 195°F <i>(Prior to S/N W120631743)</i>	1
4	2103.36	THERMOSTAT, CONTROL 110-195°F <i>(Beginning with S/N W120631743)</i>	1
5	2103.16	BOLT, HEX FLANGE, 1/4-20 X 3/8" SST	1
6	2103.38	CLAMP, 29/32" x 1/2" WIDE SST	6
7	2103.22	HOSE, BOOSTER FILL	1
8	2103.19	THERMOSTAT, HI-LIMIT FIXED SNAP 240°F	1
9	2103.20	TANK, BOOSTER <i>(All S/N's)</i> <i>(Includes Item 14)</i>	1
10	2103.22	HOSE, 1/2" ID	A/R
11	2103.23	TEE, RINSE	2
12	2103.24	FITTING, BOOSTER THERMOMETER	1
13	0302.00	THERMOMETER, 2" DIAL, 7' CAPILLARY	1
14	2103.26	PLUG, 1/8" SST	1
15	2103.27	NUT, GRIP 6-32 W/NYLON INSERT	2
16	2103.28	FITTING, BOOSTER THERMOSTAT <i>(Use with Item 3, Prior to S/N W120631743))</i>	1
17	2103.61	FITTING, BOOSTER THERMOSTAT <i>(Use with Item 3, Beginning with S/N W120631743))</i>	1
18	2103.62	FITTING, COMP. 1/4" OD X 1/8" MPT ELL J	1
19	13604.10	BUSHING, REDUCER 1/2" X 1/8"	1
20	2103.74	TUBING, 1/4" NATURAL	2 FT.
21	40014.00	COUPLER, 1/2" HOSE X 1/2" FNPT BRASS	1

Electrical Panel and Timer Assembly

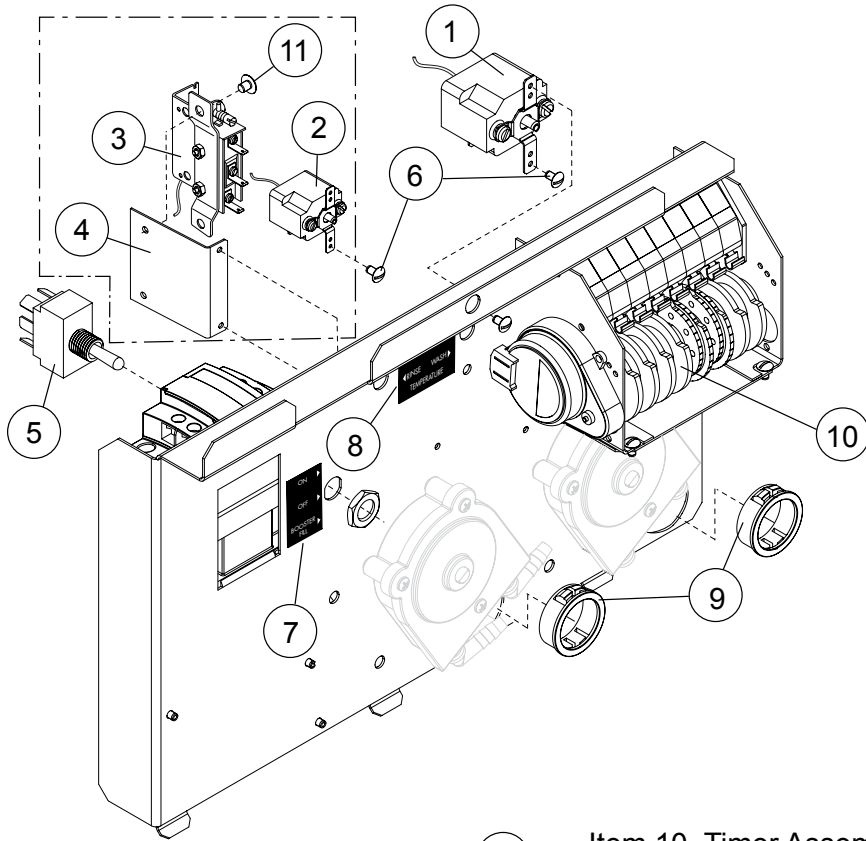

Item 10, Timer Assembly includes: Items 12 and 13

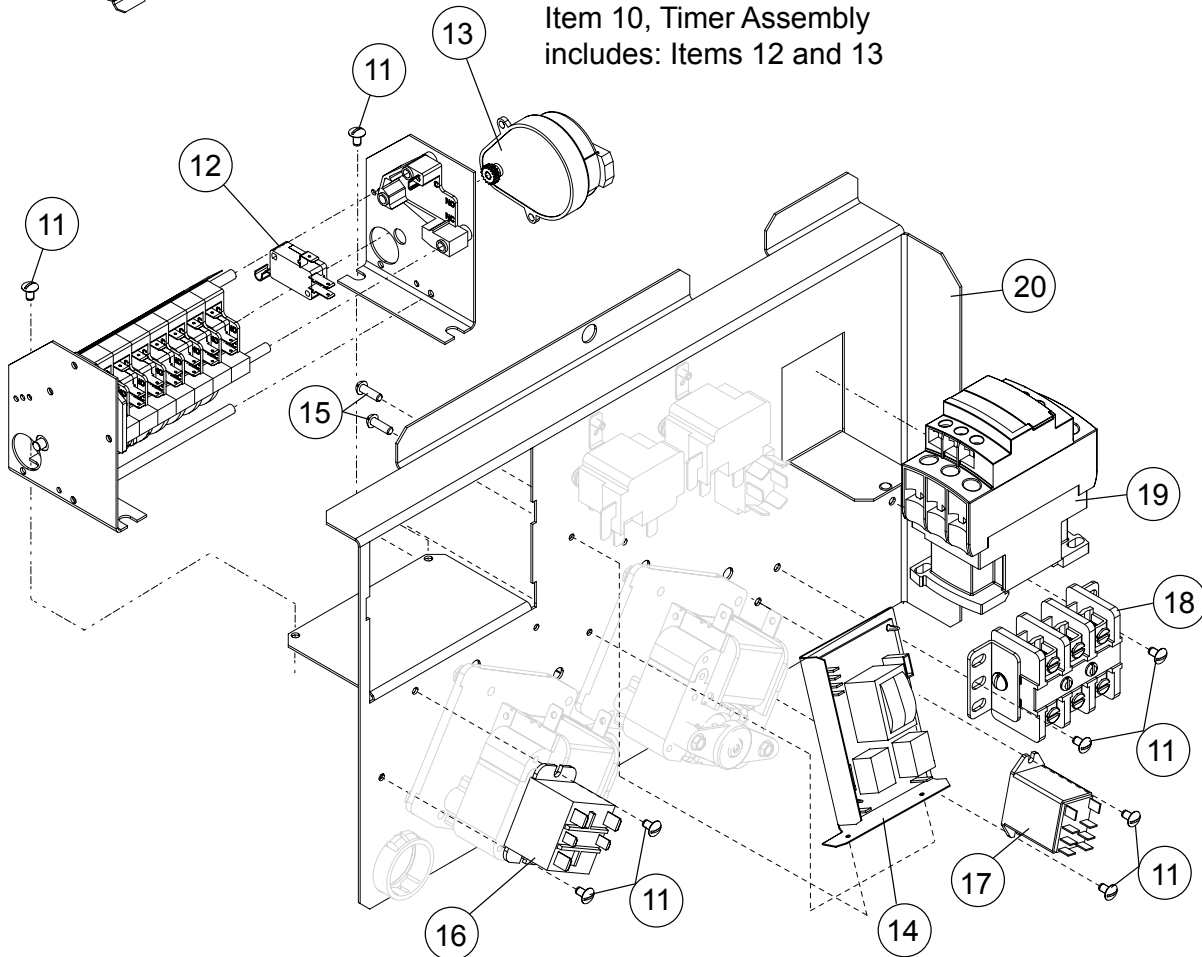

Item No.	Part No.	Description	Qty.
1	2103.29	THERMOSTAT, WASH TANK	1
2	2103.15	THERMOSTAT, CONTROL 195°F (Prior to S/N W120631743)	1
3	2103.36	THERMOSTAT, CONTROL 110-195°F (Beginning with S/N W120631743)	1
4	2103.63	BRACKET, THERMOSTAT (Use with Item 3 only)	1
5	2103.31	SWITCH, 3-POSITION, TOGGLE	1
6	2103.34	SCREW, NIBS RH 6-32 X 3/16" PHIL. SST	4
7	2103.32	LABEL, ON/OFF/BOOSTER FILL	1
8	2103.33	LABEL, WASH-RINSE TEMPERATURE	1
9	2103.35	BUSHING, 1" ID	2
10	00408.60	ASSEMBLY, TIMER (Includes Items 12, 13)	7
11	2103.59	SCREW, TRUSS SLOT, 8-32 X 1/4" SST	10
12	0411.00	SWITCH, TIMER	7
13	00501.00	MOTOR, TIMER	1
14*	2103.43*	KIT, FILL/DRAIN TIMER (All S/N's)	1
15	2103.45	SCREW, RH 4-40 X 3/16" SLOTTED SST	4
16	2103.40	RELAY, 15 AMP, 120VAC COIL	1
17	2103.46	RELAY, 120VAC, 2PDT	1
18	2103.47	BLOCK, TERMINAL	1
19	2103.48	CONTACTOR, 25/40A, 3P, 120V COIL	1
20	2103.49	PANEL, CONTROL	1

* **Note:** See Kit Installation Instructions at the end of this manual

Control Panel Assembly

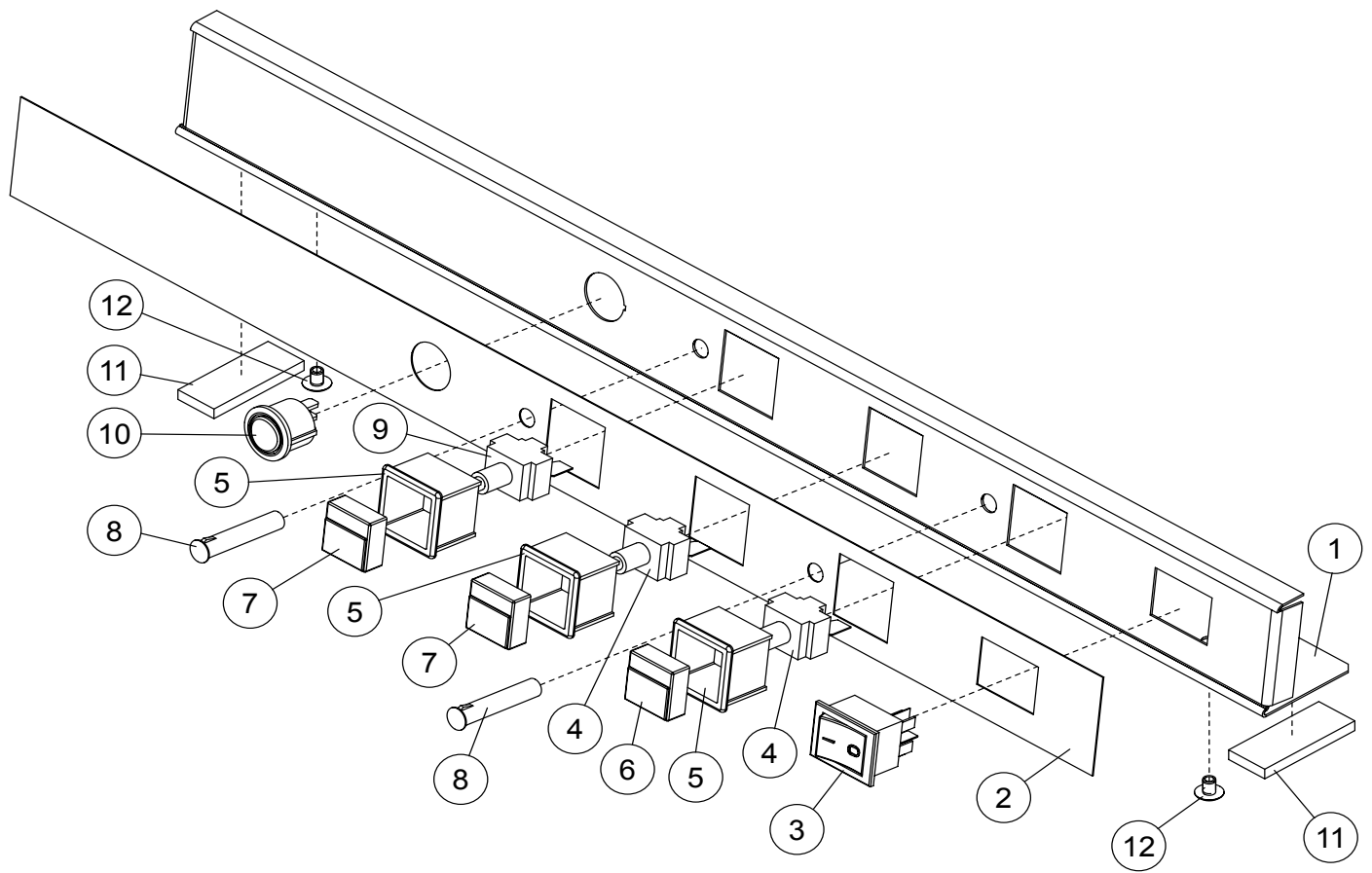

Item No.	Part No.	Description	Qty.
1	2103.42	PANEL, FACIA, UC65e	1
2	2103.44	LABEL, FACIA, UC65e	1
3	2103.50	SWITCH, ON-OFF	1
4	2103.51	CONTACT, MOMENTARY, N.O.	2
5	2103.52	HOUSING, SWITCH	3
6	2103.53	BUTTON, SWITCH (GREEN)	1
7	2103.54	BUTTON, SWITCH (GREY)	2
8	2103.55	LIGHT, INDICATOR LED, 125VAC (GREEN)	2
9	2103.56	CONTACT, SWITCH (EXTENDED WASH)	1
10	2103.57	SWITCH, MOMENTARY (PRIME)	1
11	2103.58	GASKET, STEAM	2
12	2103.59	SCREW, TRUSS SLOT., 8-32 X 1/4" SST	2

Upper Final Rinse Piping Assembly

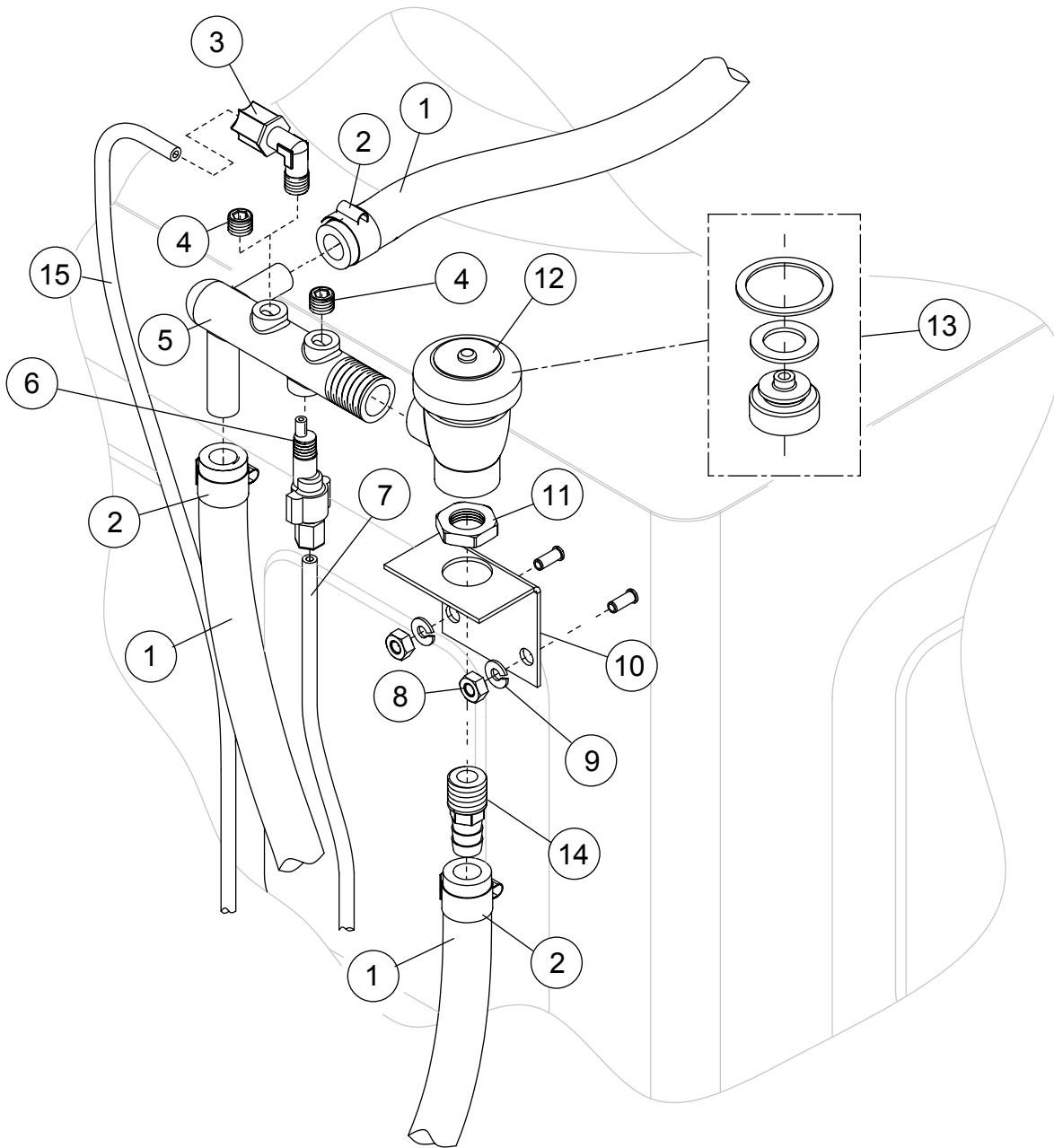

Upper Final Rinse Piping Assembly

Item No.	Part No.	Description	Qty.
1	2103.60	HOSE, RUBBER 1/2ID X .84OD	AR
2	2103.21	CLAMP, SS GEAR-MIN. 5/16-MAX.7/8	6
3	2103.62	FITT COMP 1/4OD X 1/8MPT ELL J (Prior to S/N W120631743)	1
4	2103.26	PLUG, 1/8 HEX COUNTERSUNK (Beginning with S/N W120631743)	2
5	2103.64	MANIFOLD, RINSE	1
6	2103.65	INJECTOR FITTING	1
7	2103.66	TUBING, 1/8OD X 1/16 ID	AR
8	2103.67	NUT, HEX SS 1/4-20	2
9	2103.04	WASHER, SPLIT LOCK 1/4i 304SS	2
10	2103.69	BRACKET, VACUUM BREAKER	1
11	2103.70	NUT, LOCK 1/2" NICKEL PLATED	1
12	2103.71	VACUUM BREAKER, 1/2" BRASS	1
13	2103.72	REPAIR KIT, VACUUM BREAKER 1/2"	1
14	2103.73	COUPLER 1/2 MPT X 1/2" HOSE	1
15	2103.74	TUBING, 1/4" NATURAL (Prior to S/N W120631743)	AR

Wash and Rinse Spray Arm Assemblies

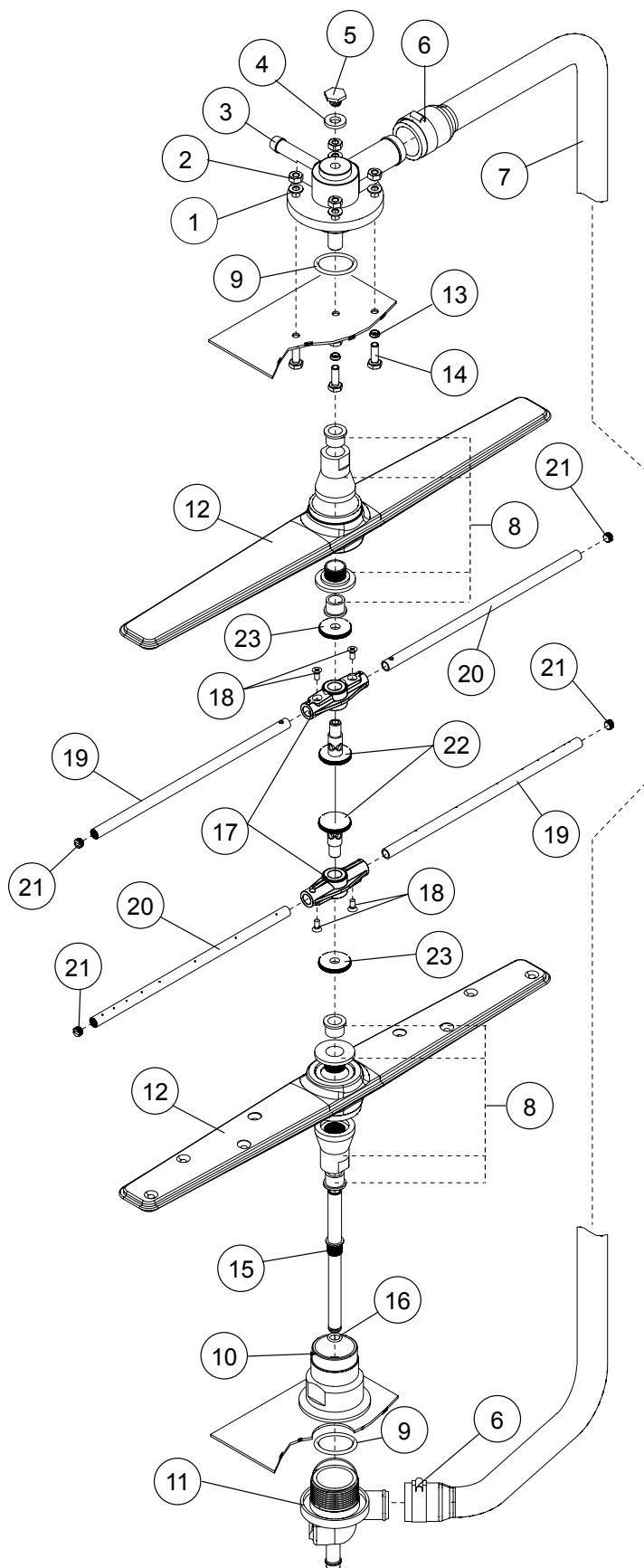

Item No.	Part No.	Description	Qty.
1	2103.75	WASHER, 17/64 id X 9/16" OD SST	4
2	2103.76	NUT, HEX 1/40-20 NYLON INSERT SST	4
3	2103.77	HUB, UPPER WASH ARM	1
4	2103.78	WASHER, PACKING	1
5	2103.79	SCREW, RETAINING	1
6	2103.80	CLAMP, HOSE GEAR 1-1/2" SST	2
7	2103.81	HOSE, UPPER WASH ARM	1
8*	2103.82	BEARING ASSEMBLY	2
9	2103.83	O-RING, 2-1/8" OD X 1-3/4" ID X 3/16"	2
10	2103.84	HUB, LOWER WASH ARM	1
11	2103.85	MANIFOLD, LOWER FWR	1
12	2103.86	WASH ARM ASSEMBLY <i>(Includes Item 8)</i>	2
13	2103.88	WASHER, NYLITE	4
14	2103.89	BOLT, 1/4-20 X 1" SST	4
15	2103.90	SHAFT, LOWER	1
16	2103.91	O-RING	1
17	2103.92	HUB, RINSE ARM, MOLDED	2
18	2103.93	SCREW, TRUSS SLOTTED 8-32 X 1/4" SST	4
19	2103.94	ARM, RIGHT-HAND RINSE (7 JETS)	2
20	2103.95	ARM, LEFT-HAND RINSE (8 JETS)	2
21	2103.96	CAP, RINSE ARM, 5/16-24	4
22	2103.97	SPINDLE, RINSE ARM	2
23	2103.98	SPACER, NUT	2
---	2103.99	RINSE ARM ASSEMBLY <i>(Includes Items 18-23)</i>	2

** Note:*

The bearing assembly, P/N [2103.82](#) includes 2 bearings, 1 locknut, and 1 wash arm hub. The bearings, locknut and hub are not available as separate service replacement parts.

Drain Pump and Lower Hose Assembly

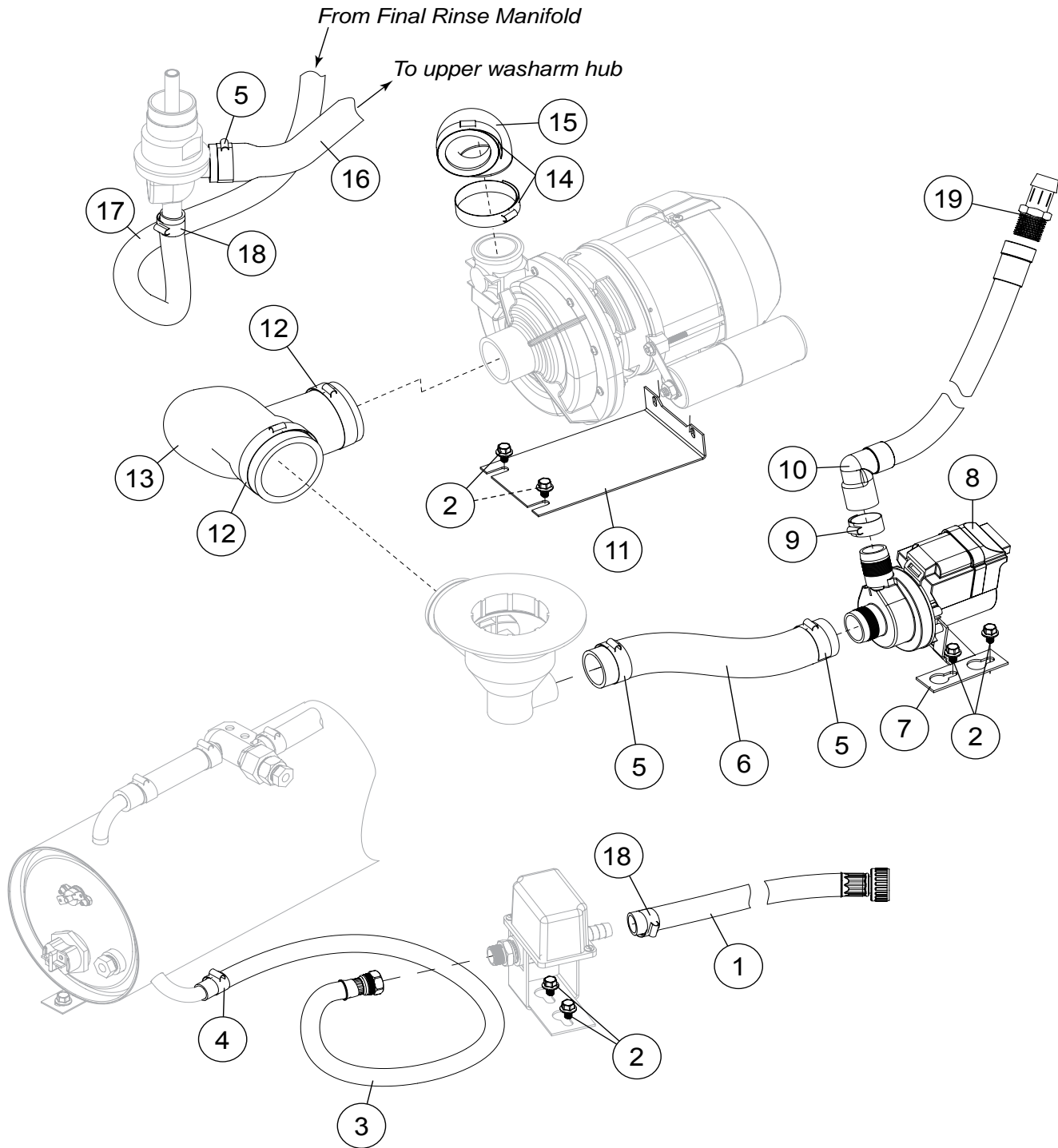

Item No.	Part No.	Description	Qty.
1	02104.00	HOSE, FILL 1/2" X 7' C/W 3/4" FNPS	1
2	2103.16	BOLT, HEX FLANGE, 1/4-20 X 3/8" SST	6
3	2103.18	HOSE, BOOSTER FILL, 1/2" X 1'	1
4	2103.17	CLAMP, HOSE GEAR-TYPE 5/16"	1
5	2104.04	CLAMP, HOSE GEAR-TYPE, 1", SST	2
6	2104.05	HOSE, DRAIN PUMP SUCTION	1
7	2104.06	BRACKET, DRAIN PUMP	1
8	2104.07	PUMP, DRAIN 115VAC	1
9	2104.08	CLAMP, HOSE GEAR-TYPE SST	1
10	2104.84	HOSE, BRAIDE	1
11	2104.09	BRACKET, WASH PUMP	1
12	2104.10	CLAMP, HOSE GEAR-TYPE 1-13/16"- 2-3/4" MAX SST	2
13	2104.11	HOSE, SUCTION WASH PUMP	1
14	2103.80	CLAMP, HOSE GEAR-TYPE, 1-1/2", SST	2
15	2104.13	HOSE, DISCHARGE WASH PUMP	1
16	2103.81	HOSE, UPPER WASH ARM	1
17	2103.22	HOSE, RUBBER 1/2" 1D X .84" OD	A/R
18	2103.21	CLAMP, HOSE GEAR-TYPE	2
19*	2103.68	COUPLER, 3/4" MPT X 3/4" HOSE BARB	1

*** NOTE:**

ITEM 19 IS STRAPPED TO THE DRAIN HOSE AS A SEPARATE PART FOR THE PLUMBING INSTALLER TO USE DURING INSTALLATION.

Wash Tank Heater and Drain Assembly

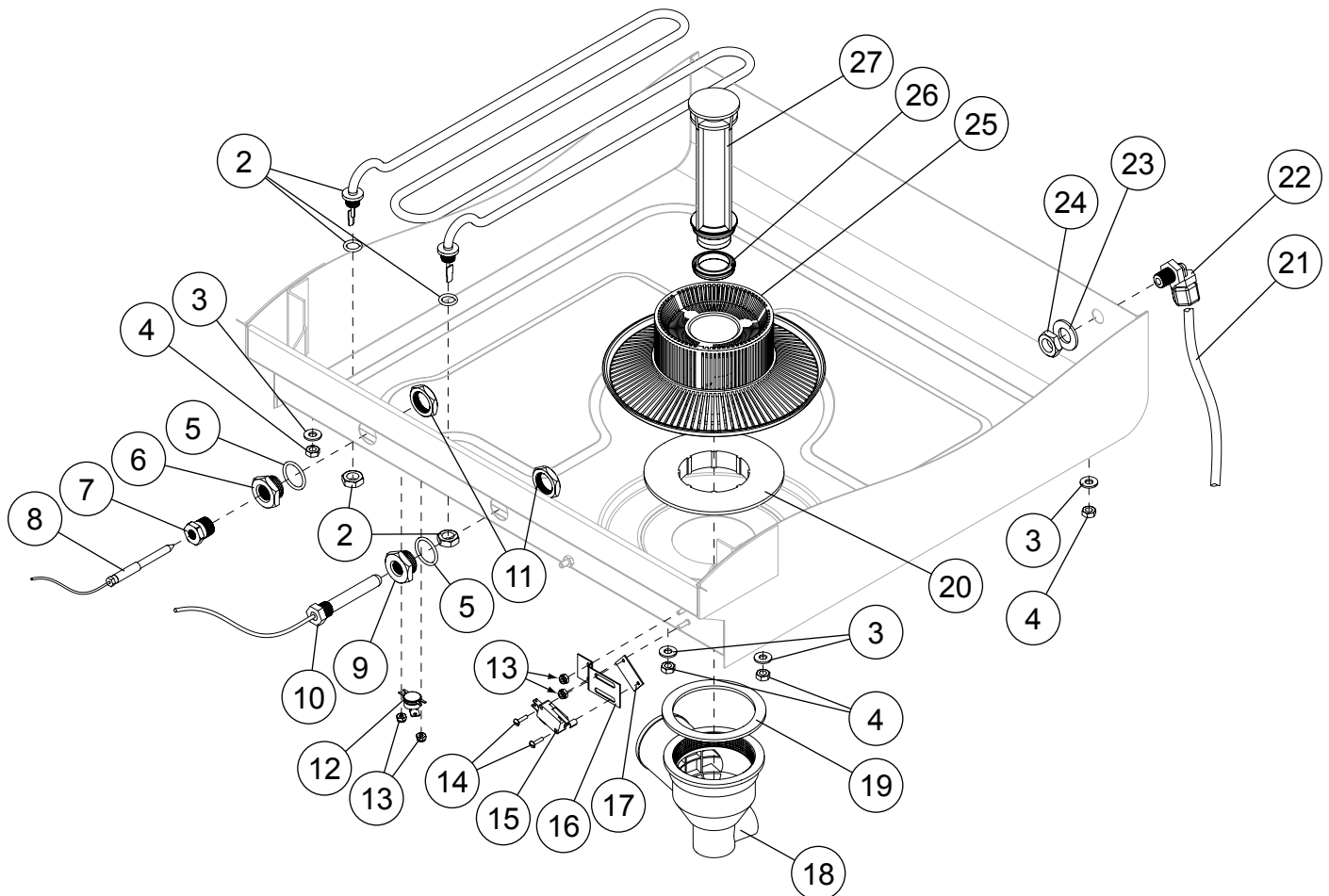
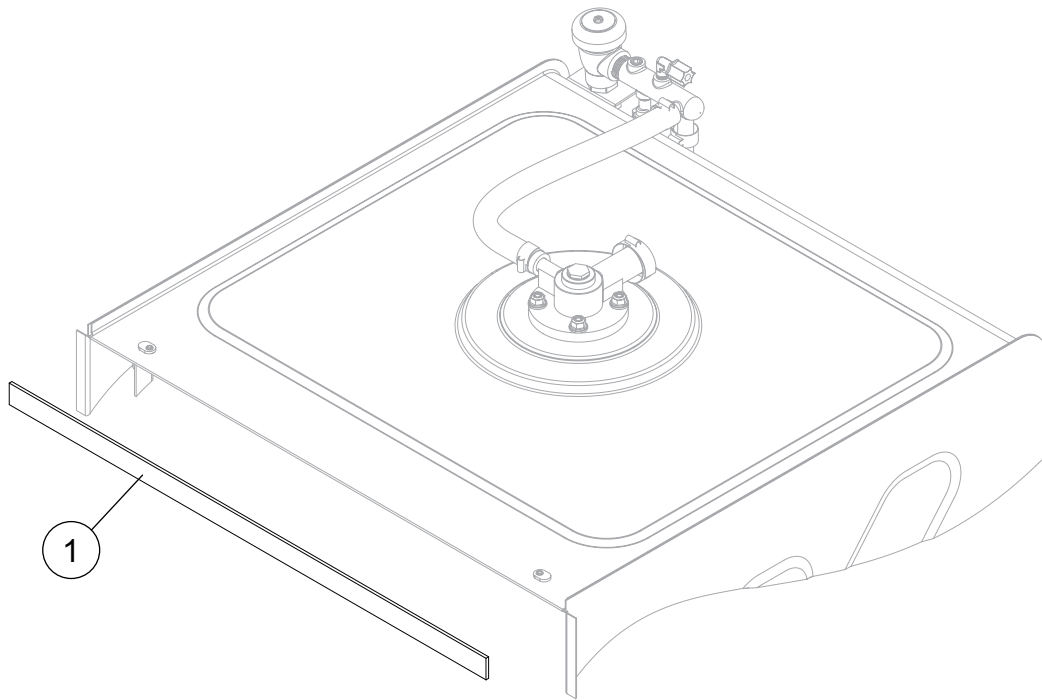

Wash Tank Heater and Drain Assembly

Item No.	Part No.	Description	Qty.
1	2104.17	GASKET, DOOR	1
2	2104.18	HEATER, WASH TANK, 2KW, 240VAC	1
3	968.00	WASHER, SPLIT LOCK 1/4" SST	4
4	2103.67	NUT, HEX 1/4-20 SST	4
5	2104.21	O-RING	2
6	2104.22	ADAPTER, THERMOSTAT	1
7	2103.28	BUSHING, THERMOSTAT	1
8	2103.29	THERMOSTAT, WASH TANK	1
9	2104.25	ADAPTER, THERMOMETER	1
10	2103.25	THERMOMETER, 2" DIAL C/W 7' CAPILLARY	1
11	2103.70	NUT, LOCK 1/2" NICKLE-PLATED	2
12	2104.28	THERMOSTAT, FIXED, SNAP 212°F	1
13	2103.27	NUT, GRIP 6-32 W/NYLON INSERT	4
14	2103.30	SCREW, 4-40 X 1/2" SST	2
15	43019.00	SWITCH, DOOR 15 AMP	1
16	2104.32	BRACKET, SWITCH	1
17	2104.33	PLATE, SWITCH NUT	1
18	2104.34	ELBOW, PUMP SUCTION	1
19	2104.35	GASKET, PUMP SUCTION	1
20	2104.36	FLANGE, PUMP SUCTION	1
21	2104.37	HOSE, 1/4" ID X 3/8" OD	A/R
22	2104.38	ELBOW, 3/8" TUBE X 1/4" NPT	1
23	2104.39	GASKET, 1/4" FIBER	1
24	2104.40	LOCKNUT, 1/4" PLASTIC	1
25	2104.41	FILTER, SUMP	1
26	2104.42	SEAL, OVERFLOW TUBE	1
27	2104.43	TUBE, OVERFLOW	1

Fill Solenoid Valve Assembly

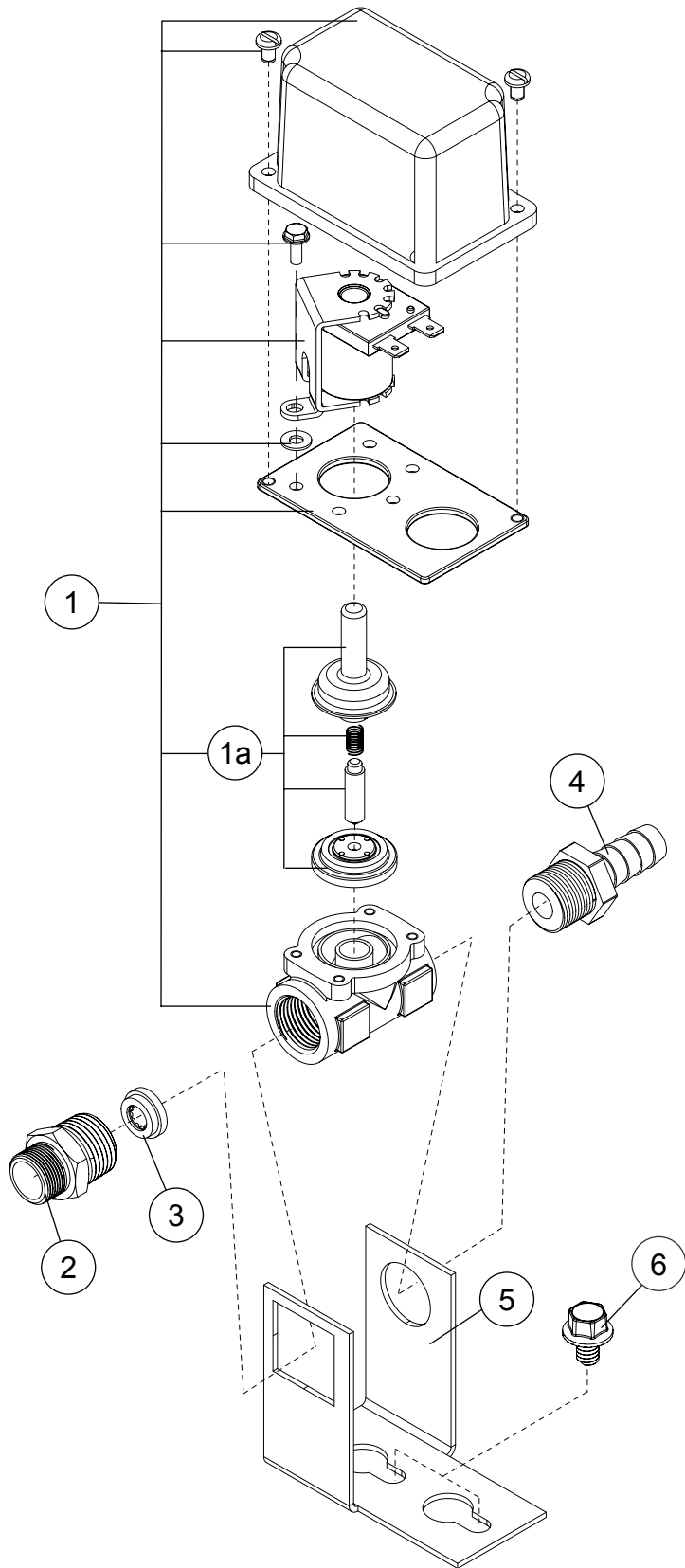

Item No.	Part No.	Description	Qty.
1	03604.00	VALVE, SOLENOID, DEMA 1/2" 115VAC/60/1 (Includes Items 1a)	1
1a	03604.30	KIT, REPAIR SOLENOID VALVE, DEMA 1/2"	A/R
2	03604.50	FITTING, FLOW DISC, DEMA	1
3	03604.10	WASHER, FLOW, DEMA	1
4	2103.73	FITTING, BARB HOSE	1
5	2104.45	BRACKET, VALVE, UC65E	1
6	2103.16	BOLT, HEX FLANGE 1/4-20 X 3/8" SST	2

Detergent Pump Assembly

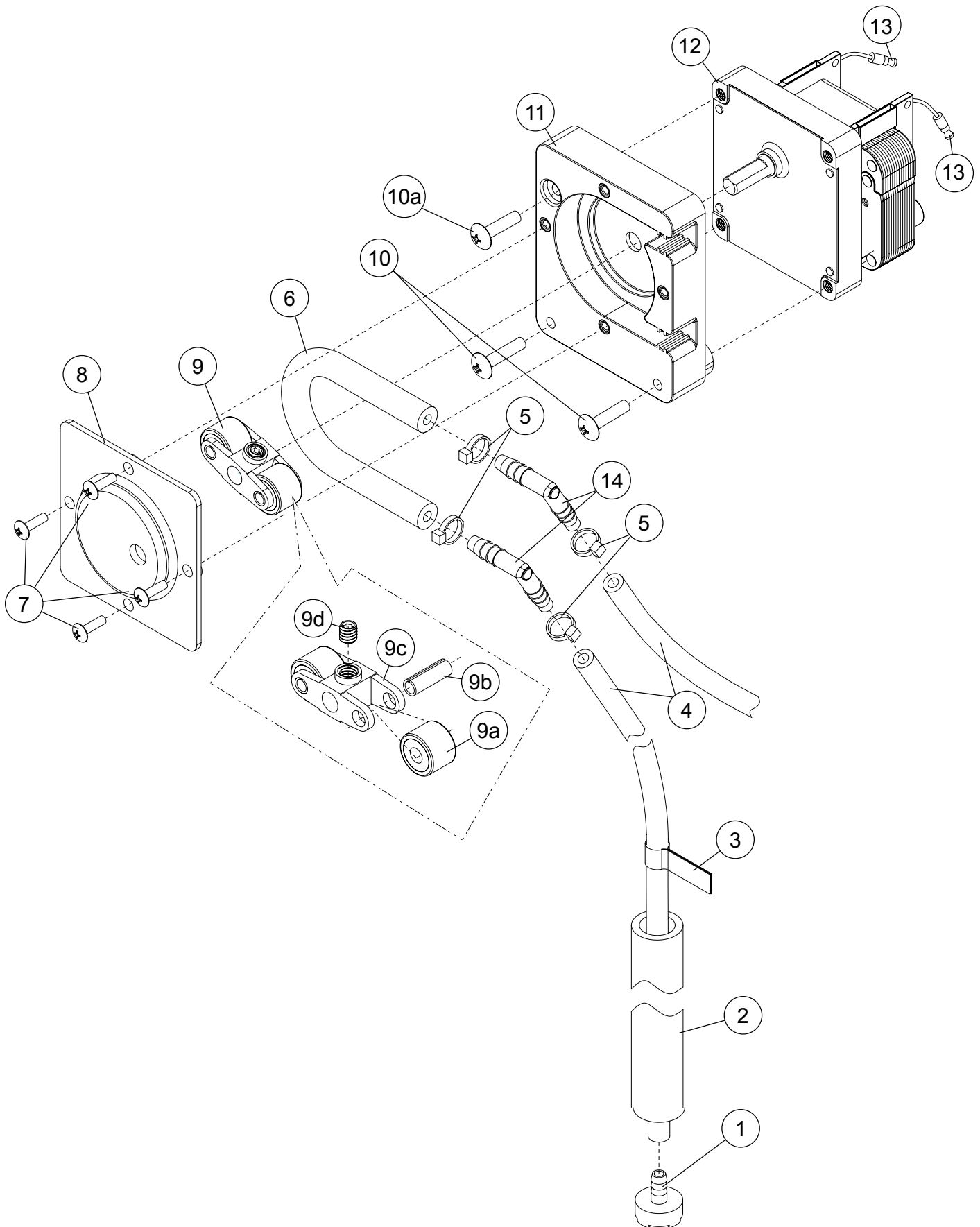

Item No.	Part No.	Description	Qty.
1	2104.47	STRAINER	1
2	2104.48	TUBE, 1/2ID X 11-7/8LG. STIFFENER	1
3	2104.49	LABEL, DETERGENT	1
4	2104.37	HOSE, 1/4ID X 3/8OD PVC	A/R
5	2104.51	TIE, NYLON 4"	4
6	2104.52	ELBOW, 1/4 HOSE BARB	1
6	00435.10	TUBE, SQUEEZE PUMP	1
7	00911.00	SCREW	4
8	00418.00	COVER, PUMP	1
9	00419.00	ASSEMBLY, ROLLER	1
9a	00423.00	ROLLER	2
9b	00422.00	PIN, ROLL	1
9c	00424.00	BEARING, CARRIAGE	1
9d	00933.00	SCREW, SET	1
10	00919.00	SCREW	2
10a	00918.00	SCREW, FILISTER HD.	1
11	00417.00	BLOCK, PUMP	1
12	00416.00	MOTOR, PUMP 115VAC	1
13	00448.00	CONNECTOR, PUMP MOTOR	2
----	00415.00	ASSEMBLY, PERI-PUMP COMPLETE (Includes Items 6-13)	1

Rinse-Aid Pump Assembly

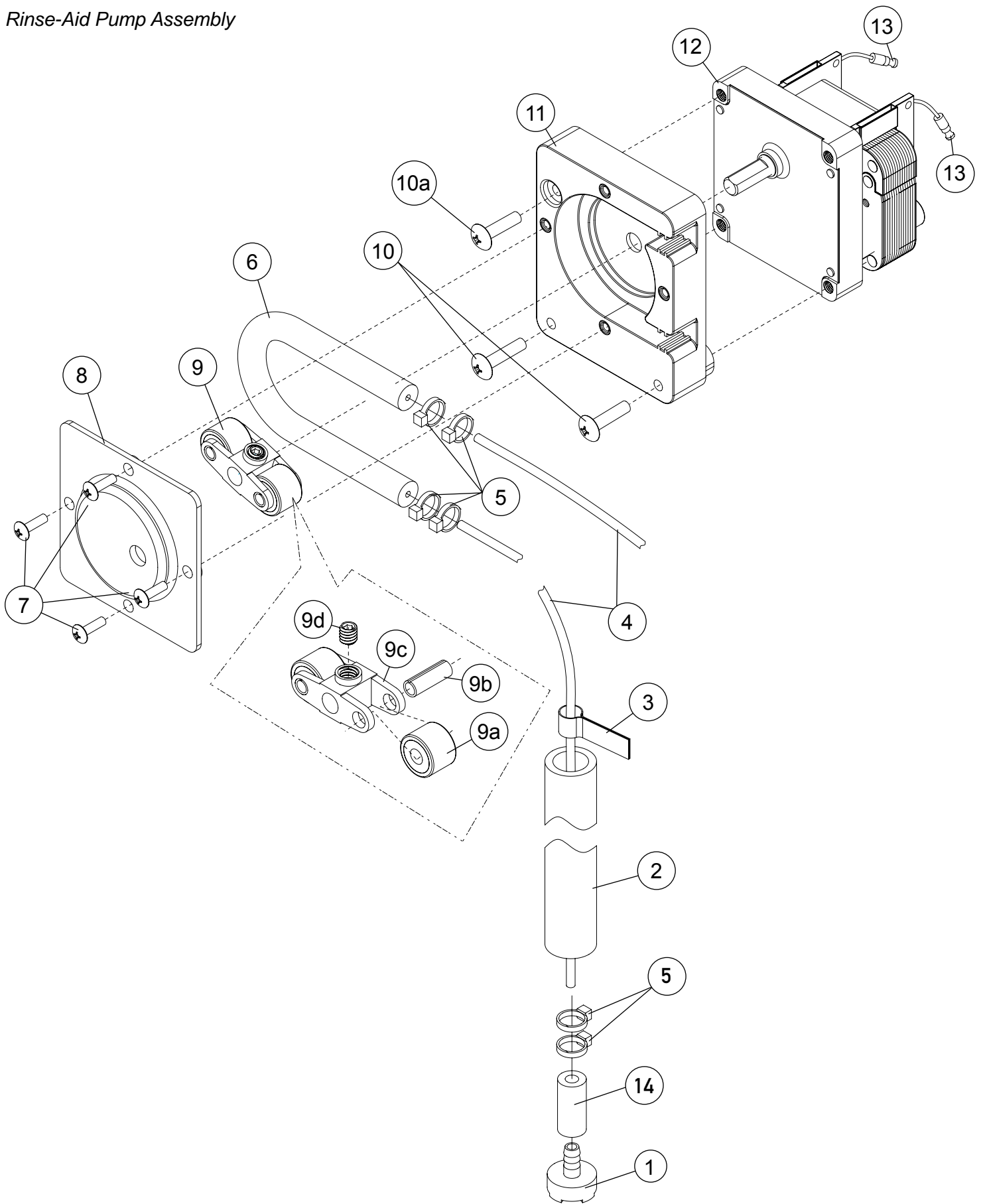

Item No.	Part No.	Description	Qty.
1	2104.47	STRAINER	1
2	2104.48	TUBE, 1/2ID X 11-7/8LG. STIFFENER	1
3	2104.49	LABEL, RINSE AID	1
4	2104.50	TUBING, 1/8" OD X 1/16 ID"	AR
5	2104.51	TIE, CABLE 4"	4
6	00836.00	TUBE, SQUEEZE PUMP	1
7	00911.00	SCREW	4
8	00418.00	COVER, PUMP	1
9	00419.00	ASSEMBLY, ROLLER	1
9a	00423.00	ROLLER	2
9b	00422.00	PIN, ROLL	1
9c	00424.00	BEARING, CARRIAGE	1
9d	00935.00	SCREW, SET	1
10	00919.00	SCREW	2
10a	00918.00	SCREW, FILISTER HEAD	1
11	00417.10	BLOCK, PUMP	1
12	00416.00	MOTOR, PUMP 115VAC	1
13	00448.00	CONNECTOR, PUMP MOTOR	2
14	2104.58	TUBE, PUMP, 1/8" ID X 2" LG.	1
----	00815.20	ASSEMBLY, PERI-PUMP COMPLETE (Includes Items 6-13)	1

Panel Assembly

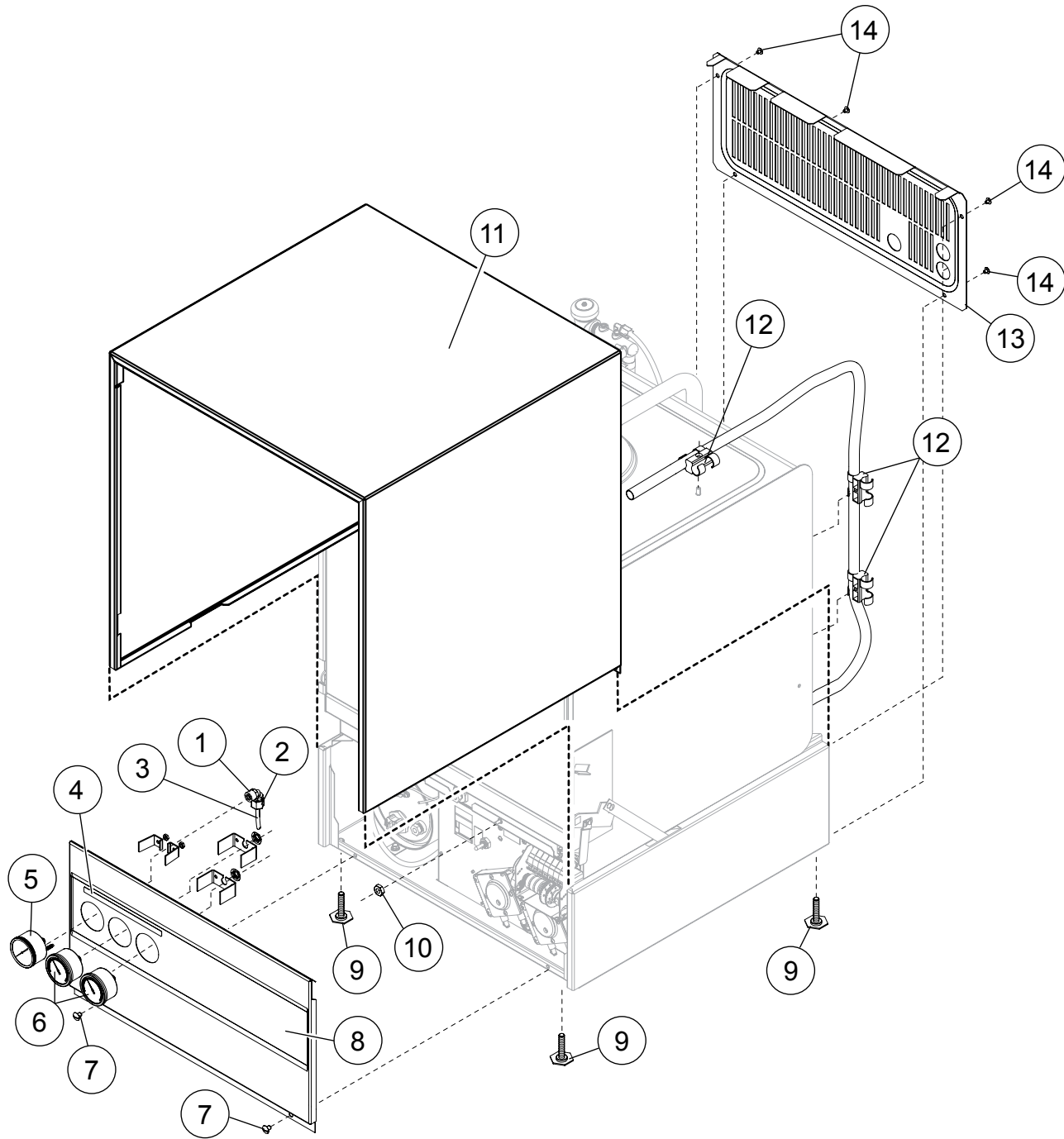

Item No.	Part No.	Description	Qty.
1	2103.62	FITT COMP 1/4" OD X 1/8 MPT ELL J	1
2	2104.60	ADAPTOR, 1/8" NPT X 1/4" TUBE	1
3	2103.74	TUBING, 1/4" NATURAL	A/R
4	2104.62	LABEL, GUAGE	1
5	2104.63	GAUGE, PRESSURE 0-60PSI	1
6	2103.25	THERMOMETER, 2" DIAL, 7' CAPILLARY	2
7	2104.65	SCREW, 1/4-20 X 5/8" TRUSS HD. PHIL. SST	2
8	2104.66	PANEL, FRONT UC65e	1
9	2104.67	FOOT, ADJUSTING	4
10	2104.68	NUT, KEPS, 10-32 SST	1
11	2104.69	WRAP, OUTER PANEL	1
12	2104.70	CLAMP, DOUBLE CONDUIT	3
14	2103.39	SCREW TRUSS SLOT SS 10-32X3/8	4
13	2104.72	PANEL, REAR	1

Door Assembly

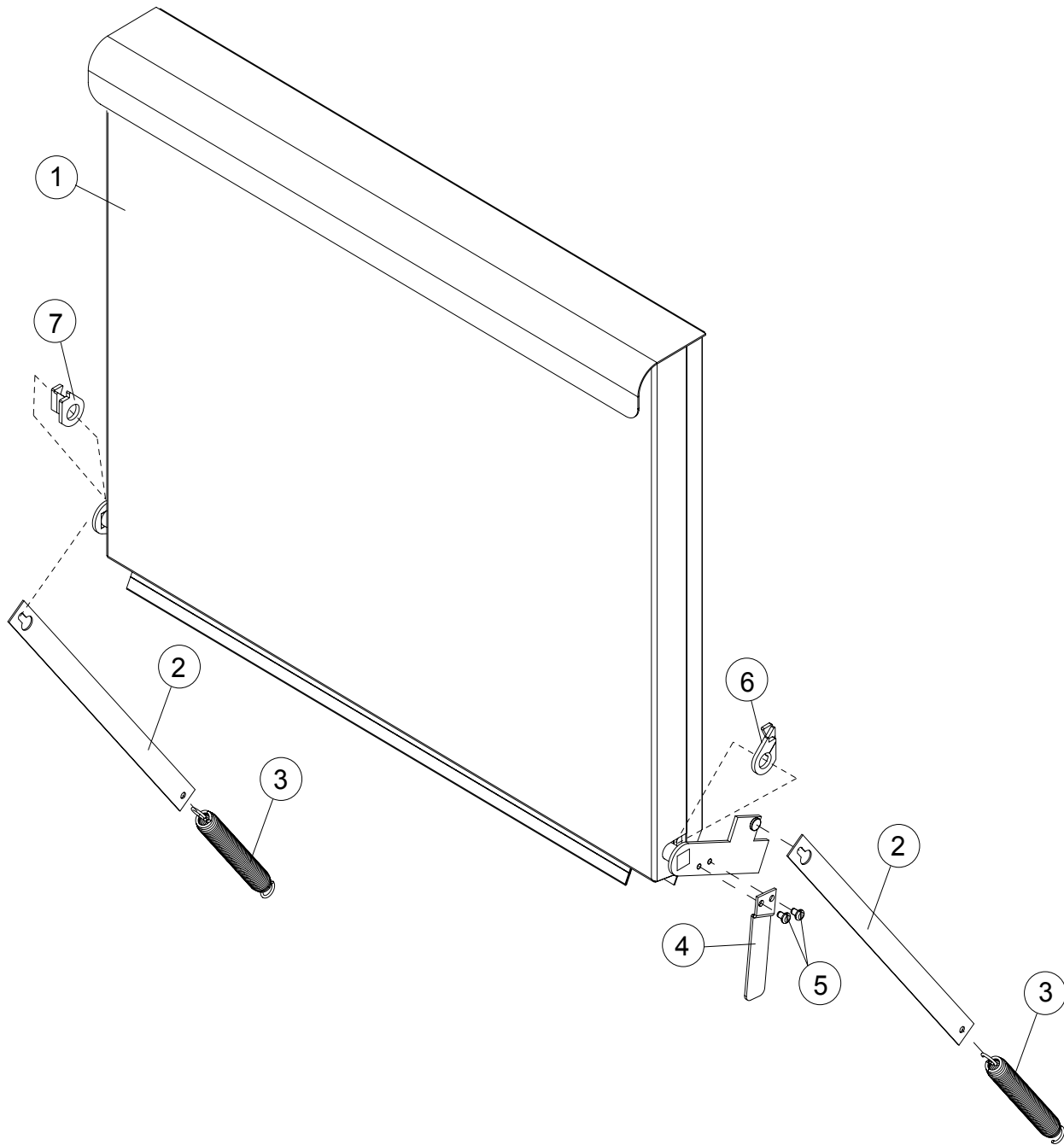

Item No.	Part No.	Description	Qty.
1	2104.73	DOOR WELDED ASSY	1
2	2104.76	ARM, DOOR SPRING	2
3	2104.77	SPRING, DOOR	2
4	2104.78	ACTUATOR, DOOR SWITCH	1
5	2103.41	SCREW, 8-32 X 3/16" PHIL. SST	2
6	2104.88	SEAL, DOOR DRIP, RH	1
7	2104.87	SEAL, DOOR DRIP, LH	1

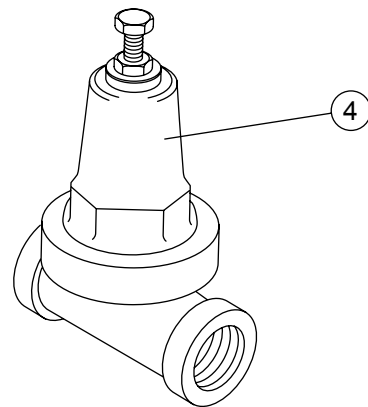
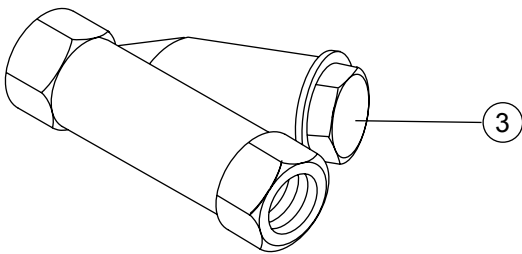
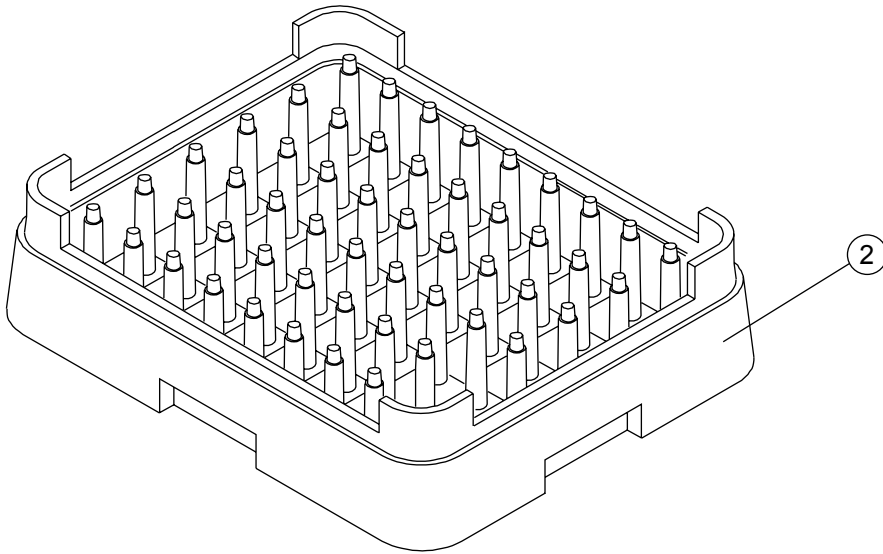
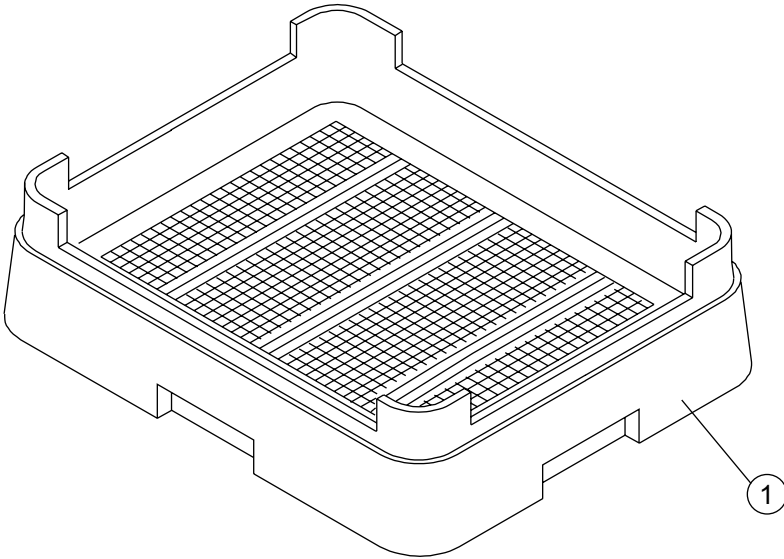

Item No.	Part No.	Description	Qty.
1	2104.80	DISH RACK, FLAT-BOTTOM	AR
2	2104.81	DISH RACK, PEG	AR
3	2104.82	STRAINER, LINE 1/2" BRONZE (OPTIONAL)	1
4	2104.83	VALVE, PRESSURE REGULATING (PRV)	1

***This Page
Intentionally
Left Blank***