



Fine Cooking Equipment For Over 80 Years

Installation, Operation & Maintenance Instructions

CEG SERIES MANUAL GRIDDLES

For Your Safety

Do NOT store or use gasoline or other flammable vapors and liquids in the vicinity of this, or any other equipment.

Warning!

Improper installation, adjustment, alteration, service or maintenance can cause property damage, injury or death. Read the installation, operation and maintenance instructions thoroughly before installing or servicing this equipment.

To Purchaser

After installation of your griddle, immediately contact your local gas supplier to obtain information in the event the user of your equipment smells gas. This information must be posted in a prominent location.

To User

RETAIN THIS MANUAL FOR FUTURE USE

Upon receipt of this griddle, inspect it thoroughly for any damage which may have occurred during shipment. If damage is observed, contact the delivery agency immediately.

- 1. Preparation For Installation:** Safe and satisfactory operation of the griddle depends, to a great extent, upon it's proper installation. It should be installed in accordance with the National Fuel Gas Code **Z223.1**, these instructions, and applicable State and Local Codes.

Installation must be made by a licensed plumber.

A gas pressure regulator is supplied with your griddle. The regulator must be installed before connecting griddle to gas supply line. *Please note: air vent can plug with grease, thereby shutting gas supply off. Install regulator in a drip-free area.*

The griddle and it's individual shutoff valve must be disconnected from the gas supply piping system during any pressure testing of that system at test pressures in excess of 1/2 psig (3.45 kPa).

The griddle must be isolated from the gas supply piping system by closing it's individual manual shutoff valve during any pressure testing of the gas supply piping system at test pressures equal to or less than 1/2 psig (3.45 kPa).

- 2. Clearances And Ventilation:** This griddle is designed for installation in non-combustible locations only with 4" clearance from sides and 6" clearance from back.

Connerton

11990 Rivera Rd. Santa Fe Springs, CA 90670
Telephone: (714) 547-9218 Fax: (714) 547-1969
www.connertoncooking.com

Keep equipment area free and clear from combustibles.

The area in front of, and above the griddle must be clear to avoid obstruction of flow of combustion and ventilation air. Means must be provided for adequate air supply and adequate clearance for air openings into the combustion chamber.

Adequate clearances must be provided in front and sides of the griddle for servicing and proper operation.

It is important that the griddle be installed under an exhaust hood which is adequate to remove the products of combustion and cooking vapors. Sufficient make-up air must also be provided to the space where the griddle is located to replace that removed through the exhaust hood.

3. Gas Piping: Make sure the gas pressure regulator supplied with the griddle is installed correctly.

Connect outlet side of regulator to griddle. The regulator is set at 4 inches w.c. on natural gas and 11 inches w.c. on propane gas. A 1/8" pressure tap is provided on the gas manifold at the front of the griddle for checking the gas pressure. **Please note: air vent on regulator can plug with grease, thereby shutting gas supply off. Install regulator in drip-free area.**

Connect griddle to the gas supply line. Under no circumstances should the gas supply line be smaller than the inlet pipe on the griddle. A gas shutoff valve must be installed in the gas supply line upstream of the griddle for complete shutdown and service. Use pipe sealant on all pipe joints. Sealant must be resistant to the action of L.P. gasses.

For proper performance, the griddle must be level. If legs are provided, adjust feet at bottom of legs to level griddle. If legs are not provided, seal the base of the griddle to the countertop with silicone.

If the griddle is supplied with casters, the installation must be made with a connector that complies with the Standard for Connectors for Movable Gas Appliances **ANSI Z21.69**, and a quick-disconnect device that complies with the Standard for Quick-Disconnect Devices for Use With Gas Fuel, **ANSI Z21.41**. Adequate means must be provided to limit the movement of the griddle without depending on the connector and the quick-disconnect device or it's associated piping to limit the griddle movement. Restraining device should be connected to legs or back of body.

IMPORTANT: Check all gas connections for leaks, using a soap and water solution.

DO NOT USE AN OPEN FLAME FOR CHECKING PURPOSES

4. Lighting And Relighting Of Griddle:

- A.** Turn all burner valves and pilot valves to "OFF". Wait 5 minutes.
- B.** Turn on pilot valves and light pilots. Adjust flame height to approximately 1/2".
- C.** Turn on burner valves to operate your griddle.
- D.** For complete shutdown, turn off all valves and the gas shutoff valve located upstream of the griddle.
- E.** To relight, repeat above procedures.

5. Care And Maintenance:

Contact factory, factory representative, or a local service company to perform maintenance and repairs. **Please Note: Contact factory before any warranty repairs are made.**

- A.** To clean griddle plate, use warm water, a mild cleanser and scouring pad.
- B.** At least once per day, clean and empty grease pan.
- C.** Periodically, but not less than once every 3 months, clean burner orifices using warm water and wire brush. *Make sure equipment is cold before removing burners and orifices.*

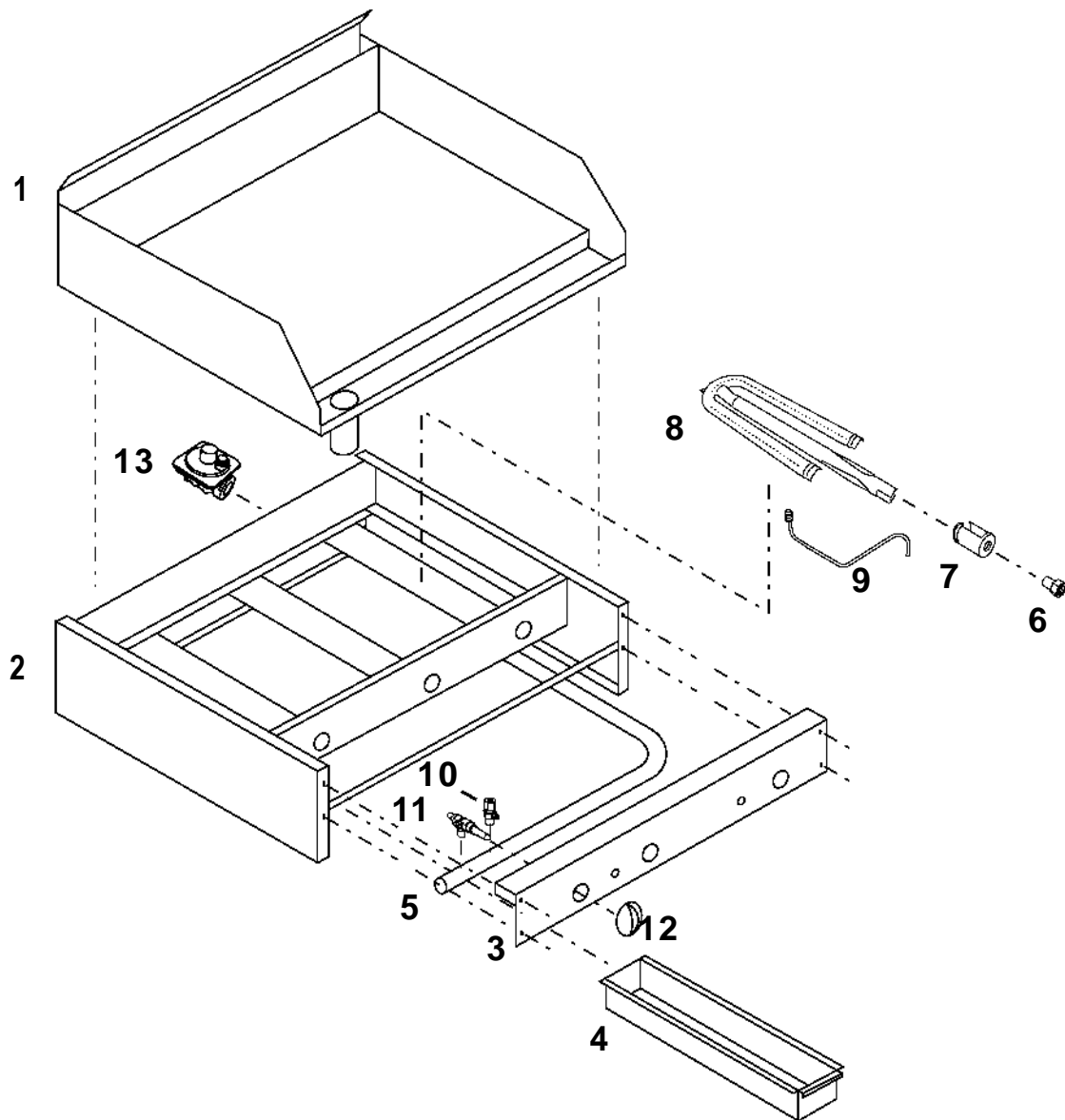

CG MANUAL GRIDDLES

1	10-475-xx	griddle plate	8	10-150-00	burner
2	10-400-xx	body	9	10-350-00	pilot stem & tip
3	10-425-xx	front panel	10	00-225-00	pilot valve
4	10-450-00	grease drawer	11	00-250-00	manual control valve
5	10-300-xx	gas manifold pipe	12	00-500-00	chrome knob
6	10-200-01	orifice hood (<i>nat gas</i>)	12a	15-251-02	**brushed s/s knob
6a	10-200-02	orifice hood (<i>LP</i>)	13	00-275-01	pressure regulator (<i>nat gas</i>)
7	10-675-00	air shutter	13a	00-275-02	pressure regulator (<i>LP</i>)

for part numbers ending in xx specify model size

** items not pictured

TROUBLESHOOTING GUIDE

Condition	Probable Cause	Solution
Small/no burner flame	Regulator failure	Unplug regulator vent hole or replace regulator.
	Plugged orifice hood	Unplug hole or replace orifice.
	Plugged burner port	Unplug burner port(s).
Small/no pilot flame	Pilot valve setting	Adjust flame height.
	Plugged pilot tip	Unplug pilot ports.
Yellow burner flame	Improper air shutter setting	Increase air shutter setting until flame is blue.
	Enlarged orifice hood	Replace w/correct orifice.
Flame lifts off burner	Improper air shutter setting	Decrease air shutter setting until flame sits on burner.
	Plugged orifice hood	Unplug orifice hole or replace orifice.
	Improper level setting	Adjust level w/feet or shims.
Too hot/cold	Improper control setting	Adjust control setting or replace control.
	Improper level setting	Adjust level w/feet or shims.

LIMITED WARRANTY

The Connerton warrants to the original user for a period of one year from date of installation, not to exceed 18 months from date of shipment by Connerton, that the equipment manufactured is free from defects in material or workmanship.

Our obligation under this warranty shall be limited to furnishing without charge any part of said product which, upon examination by The Connerton shall prove to be defective. Parts wear is not considered a defect. The Connerton will not be responsible for labor or transportation charges incidental to the replacement of same.

The Connerton assumes no responsibility for failure of the equipment to operate properly due to improper installation or operation. This warranty applies to all equipment that has been unaltered, properly installed and maintained in accordance with national and local codes and in accordance with the installation and operating instructions included with this equipment.

This warranty does not extend to normal maintenance items, including but not limited to, air and gas adjustments and adjustments to pilot flames. Proper installation, adjustments, and initial checkout is the responsibility of the dealer, the owner-user or installer and not that of The Connerton.

Please fill out and refer to the following when contacting the factory:

Model # CEG _____ **-M** **Serial#** _____ **Gas Type:** _____ **Purchase Date:** _____