



# Installation, Operation & Maintenance Instructions

## CEG SERIES THERMOSTATIC GRIDDLES

### For Your Safety

Do NOT store or use gasoline or other flammable vapors and liquids in the vicinity of this, or any other equipment.

### ⚠ Warning!

Improper installation, adjustment, alteration, service or maintenance can cause property damage, injury or death. Read the installation, operation and maintenance instructions thoroughly before installing or servicing this equipment.



11990 Rivera Rd. Santa Fe Springs, CA 90670  
Telephone:(714) 547-9218 (562) 464 - 9901  
[www.connertoncooking.com](http://www.connertoncooking.com)

## To Purchaser

After installation of your griddle, immediately contact your local gas supplier to obtain information in the event the user of your equipment smells gas. This information must be posted in a prominent location.

## To User

### RETAIN THIS MANUAL FOR FUTURE USE

Upon receipt of this griddle, inspect it thoroughly for any damage which may have occurred during shipment. If damage is observed, contact the delivery agency immediately.

1. **Preparation For Installation:** Safe and satisfactory operation of the griddle depends, to a great extent, upon its proper installation. It should be installed in accordance with the National Fuel Gas Code **Z223.1**, these instructions, and applicable State and Local Codes.

**The installation must be done by a licensed plumber.**

A gas pressure regulator is supplied with your griddle. The regulator must be installed before connecting the griddle to the gas supply line. *Please note that air vent can plug with grease, thereby shutting gas supply off. Install regulator in a drip-free area.*

The griddle and its individual shutoff valve must be disconnected from the gas supply piping system during any pressure testing of that system at test pressures in excess of 1/2 psig (3.45 kPa).

The griddle must be isolated from the gas supply piping system by closing its individual manual shutoff valve during any pressure testing of the gas supply piping system at test pressures equal to or less than 1/2 psig (3.45 kPa).

2. **Clearances And Ventilation:** This griddle is designed for installation in non-combustible locations only with 4" clearance from sides and 6" clearance from back.

**Keep equipment area free and clear from combustibles.**

The area in front of and above the griddle must be clear to avoid obstruction of flow of combustion and ventilation air. Means must be provided for adequate air supply and adequate clearance for air openings into the combustion chamber.

Adequate clearances must be provided in front and sides of the griddle for servicing and proper operation.

It is important that the griddle be installed under an exhaust hood which is adequate to remove the products of combustion and cooking vapors. Sufficient make-up air must also be provided to the space where the griddle is located to replace that removed through the exhaust hood.

3. **Gas Piping:** Make sure the gas pressure regulator supplied with the griddle is installed correctly. Connect the outlet side of regulator to griddle. The regulator is set at 4 inches w.c. on natural gas and 11 inches w.c. on propane gas. A 1/8" pressure tap is provided on the gas manifold at the front of the griddle for checking the gas pressure. **Please note that air vent on regulator can plug with grease, thereby shutting gas supply off. Install regulator in drip-free area.**

Connect the griddle to the gas supply line. Under no circumstances should the gas supply line be smaller than the inlet pipe on the griddle. A gas shutoff valve must be installed in the gas supply line upstream of the griddle for complete shutdown and service. Use pipe sealant on all pipe joints. Sealant must be resistant to the action of L.P. gasses.

For proper performance, the griddle must be level. If legs are provided, adjust feet at bottom of legs to level griddle. If legs are not provided, seal the base of the griddle to the countertop with silicone.

If the griddle is supplied with casters, the installation must be made with a connector that complies with the Standard for Connectors for Movable Gas Appliances **ANSI Z21.69**, and a quick-disconnect device that complies with the Standard for Quick-Disconnect Devices for Use with Gas Fuel, **ANSI Z21.41**. Adequate means must be provided to limit the movement of the griddle without depending on the connector and the quick-disconnect device or its associated piping to limit the griddle movement. Restraining device should be connected to legs or back of body.

**IMPORTANT: Check all gas connections for leaks, using a soap and water solution. DO NOT USE AN OPEN FLAME FOR CHECKING PURPOSES**

#### 4. Lighting And Relighting of Griddle:

- A. Turn all pilot valves and thermostat knob(s) to "OFF". Wait 5 minutes.
- B. Turn on pilot valves and light pilots. Adjust flame height to approximately 1/2".
- C. Turn on thermostat knobs to operate your griddle.
- D. For complete shutdown, turn off all thermostat knobs, pilot valves, and the gas shutoff valve located upstream of the griddle.
- E. To relight, repeat the above procedures.

#### 5. Care And Maintenance:

Contact factory, factory representative, or a local service company to perform maintenance and repairs.

**Please Note: Contact factory before any warranty repairs are made.**

- A. To clean griddle plate, use warm water, a mild cleanser and scouring pad.
- B. At least once per day, clean and empty the grease pan.
- C. Periodically, but not less than once every 3 months, clean burner orifices using warm water and wire brush. *Make sure the equipment is cold before removing burners and orifices.*

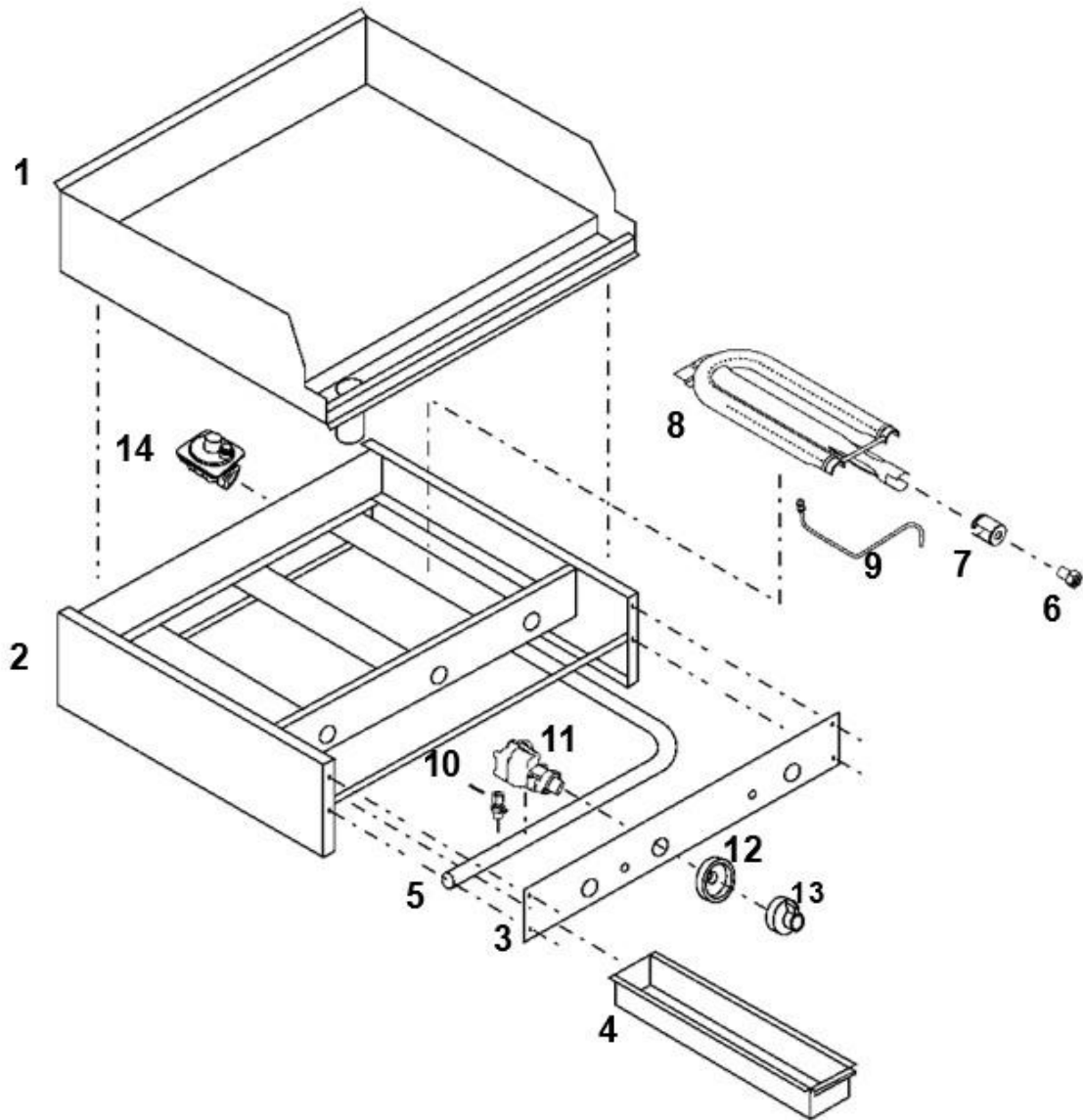

## CEG THERMOSTATIC GRIDDLES

1	05-476-DS	griddle plate	10	00-225-00	pilot valve ( <i>straight</i> )
2	05-400-DS	body	11	15-251-00	New style t-stat for CG * CEG
3	05-426-DS	front panel	12	00-525-00	bezel for old style thermostat
4	05-450-00	grease drawer	13	05-550-00	dial for old style thermostat
5	05-301-DS	gas manifold pipe	13a	15-251-02	**knob for new style thermostat
6	05-200-01	orifice hood ( <i>nat. gas</i> )	13b	15-251-01	**numbered dial plate for new style thermostat
6a	05-200-02	**orifice hood ( <i>LP</i> )	14	00-275-01	gas pressure regulator ( <i>nat. gas</i> )
7	00-675-00	air shutter	14a	00-275-02	gas pressure regulator ( <i>LP</i> )
8	05-150-00	tubular burner			
9	05-350-00	pilot stem & tip			

\*\* For part numbers ending in xx specify model size. (For example: 05-400-48 for a CEG-48).

# TROUBLESHOOTING GUIDE

Condition	Probable Cause	Solution
Small/no burner flame	Regulator failure	Unplug regulator vent hole or replace regulator.
	Thermostatic calibration	Re-calibrate thermostat.
	By-pass setting	Adjust by-pass setting.
	Plugged orifice hood	Unplug hole or replace orifice.
	Plugged burner port	Unplug burner port(s).
Small/no pilot flame	Pilot valve setting	Adjust flame height.
	Plugged pilot tip	Unplug pilot ports.
Yellow burner flame	Improper air shutter setting	Increase air shutter setting until The flame is blue.
	Enlarged orifice hood	Replace w/correct orifice.
Flame lifts off burner	Improper air shutter setting	Decrease air shutter setting until flame sits on burner.
	Plugged orifice hood	Unplug orifice hole or replace orifice.
	Improper level setting	Adjust level w/feet or shims.
Too hot/cold	Improper control setting	Adjust control setting or replace control.
	Improper level setting	Adjust level w/feet or shims.
	Thermostatic calibration	Re-calibrate thermostat and by-pass.

## CONNERTON LIMITED WARRANTY Effective January 2020

CONNERTON (Company) warrants to the original owner that the product be free from defects in materials and/or workmanship. This warranty shall apply to units properly installed in a static location only and be in effect for two (2) years from the date of purchase but shall not exceed 30 months from the date of shipment from the Company. \*2nd year warranty covers parts only. \*\* Travel/mileage charges will not apply. The warranty is limited, at the option of the Company to repair or replace any part found to be defective. This warranty covers normal labor charges for products or parts installed within the United States and Canada only. Labor charges shall be covered to the extent that the performance is effected within fifty (50) miles from a Company Authorized Servicer.

The product is intended for commercial purposes only. This warranty is void if the product is used for other than commercial purposes. Replacement parts must be supplied by a Company Authorized Servicer and defective parts returned intact to the same, when requested. Documents verifying ownership and installation dates are required. Broiler grates and radiant are warranted (part only) for 90 days.

THE WARRANTY DOES NOT COVER Misuse, abuse, or improper installation, (such as use in residential application). Damages and/or failures due to alteration/modification by other than an

authorized servicer. Damage incurred during transit and/or handling. Damage resulting from the use of other than genuine CONNERTON parts. Damage resulting from the use of or exposure to harsh chemicals or improper cleaning procedures. Damages caused by flood, fire or other acts of nature. The Company shall not be responsible or liable for any incidental or consequential damage and/or injury, claims of loss of use, loss of product or profit.

THE OWNER SHALL BE RESPONSIBLE FOR Proper installation (as detailed in the owner's manual) and in accordance with local codes. All maintenance, adjustments, cleaning, and providing adequate clearances. Making the unit reasonable accessible for service. The use of only authorized servicers for needed repairs.

PROCEDURE FOR REQUESTING WARRANTY SERVICE All services must be prearranged by the Company prior to works being performed. Contact CONNERTON service department at (714)-547-9218 furnish complete model and serial numbers and a copy of the purchase invoice and describe nature of the problem.

THIS WARRANTY CONSTITUTES THE EXCLUSIVE REMEDY OF THE COMPANY. THIS WARRANTY SET FORTH WITHIN HEREIN IS EXCLUSIVE AND IN LIEU OF ANY/ALL OTHER WARRANTIES EITHER EXPRESSED OR IMPLIED, INCLUDING BUT NOT LIMITED TO WARRANTIES OF MERCHANTABILITY AND/OR FITNESS FOR A PARTICULAR PURPOSE.

## **Non-Commercial Warranty Restriction**

**CONNERTON Appliances are only fully warranted for COMMERCIAL USE.**

When installed and/or used in other applications, such as but not limited to Residential / Household applications, the warranty covers parts only, for 1 (one) year from the original date of purchase and the following conditions apply.

Owner must furnish a complete model and serial number and proof of purchase less than one year old.

Owner must arrange for a qualified technician to inspect/diagnose make all repairs COMPANY DOES NOT COVER ANY CHARGES RELATED TO... labor, travel, mileage, or freight charges. Only the replacement parts and standard delivery charges are covered.

When the above information is available, Owner or technician, please contact CONNERTON at (562) -464-9901 or

[Orders@connertoncooking.com](mailto:Orders@connertoncooking.com)

**\*\* (excluding special order items)...most parts can ship within 24 hours.**