

Convotherm maxx pro

high definition



Combi Oven
Convotherm maxx pro

Floor-standing models
Installation Manual UL, USA - Original, ENG

Advancing Your Ambitions

FOR THE INSTALLER, OPERATOR, RESPONSIBLE OWNER

FOR YOUR SAFETY

Do not store or use gasoline or other flammable vapors or liquids in the vicinity of this or any other unit.



WARNING

Improper installation, adjustment, alteration, service or maintenance can cause property damage, injury and death. Read the installation, operating and maintenance instructions thoroughly before installing or servicing this equipment.



WARNING

Disconnect power at the main external power switch before servicing or repairing a combi oven.



WARNING

To reduce the risk of electric shock, do not remove or open cover. No user serviceable parts inside. Refer servicing to qualified personnel. Disconnect power supply before servicing.

AVERTISSEMENT

Afin de réduire le risque d'électrocution, ne pas retirer ou ouvrir le capot. Aucune pièce réparabile ne se trouve à l'intérieur. Confier le dépannage à du personnel qualifié. Débrancher l'alimentation électrique avant réparation.

IMPORTANT

IT IS COMPULSORY TO POST INSTRUCTIONS WHICH ARE TO BE FOLLOWED IN THE EVENT THE USER SMELLS GAS. THESE INSTRUCTIONS MUST BE LOCATED IN A PROMINENT LOCATION, AND BE FULLY UNDERSTOOD BY ALL USERS OF THIS EQUIPMENT. THIS INFORMATION NEED TO BE OBTAINED FROM YOUR LOCAL GAS SUPPLIER.

ALL SERVICE MUST BE PERFORMED BY A QUALIFIED CONVOTHERM-BRAND AUTHORIZED TECHNICIAN.

KEEP AREA FREE AND CLEAR OF COMBUSTIBLES.

Installation

- Installation of this unit must be done by a licensed professional when installed in the Commonwealth of Massachusetts.
- The wiring diagram is located on the inner part of the side panel.

Customer documentation

- The customer documentation is part of the combi oven.
- Keep the customer documentation manuals handy at all times so that you can look up any required information.
- Keep the customer documentation manuals for the entire life of the unit.
- Carefully read the installation manual, the operating manual, and the operating instructions before using, handling, and working on this unit.
- If you transfer the combi oven to a new owner, make sure to give the new owner the customer documentation manuals as well.

Table of Contents

1	General	7
1.1	Environmental Protection	7
1.2	Identifying Your Combi Oven	7
1.3	Customer Documentation Structure	10
1.4	About This Installation Manual	10
1.5	Safety Information That Must Be Read without Exception	11
2	Configuration and Functions	12
2.1	The Combi Oven's Configuration and Functions	12
2.2	Operating Panel Layout and Functions	14
3	For Your Safety	15
3.1	Basic Safety Instructions	15
3.2	Your Combi Oven's Intended Use	16
3.3	Warning Labels on the Combi Oven	17
3.4	Hazards posed by the unit	20
3.5	Safety Devices	22
3.6	Staff and Work Area Requirements	24
3.7	Personal protective equipment	26
4	Transportation	27
4.1	Transporting the unit to the installation location	27
4.2	Preparing for Unpacking	27
4.3	Included equipment and parts	28
5	Setup	29
5.1	Adjacent Systems	29
5.2	Installation location requirements	29
5.3	Removing the unit from the pallet	33
5.4	Setting Up the Unit on the Floor	35
6	Installation	37
6.1	Electrical installation	37
6.1.1	Planning the Electrical Installation	37
6.1.2	Performing the Electrical Installation	38
6.1.3	Connecting the energy optimization system	38
6.1.4	Connecting the Signal Tower	40
6.1.5	Connecting the Water Treatment Filter Monitoring System	42
6.2	Gas Installation	44
6.2.1	Planning the Gas Installation	44
6.2.2	Forced air burner positions	45
6.2.3	Performing the Gas Installation	46
6.2.4	Measuring the Supply Flow Pressure	47
6.2.5	Measuring the Exhaust Gas Values	47
6.3	Network Connection	48
6.3.1	Planning the Network Connection	48
6.3.2	Making the Network Connection	48
6.4	Water connections	49
6.4.1	Water supply	49
6.4.2	Checking the water quality	51

Table of Contents

6.4.3	Drain Connection	51
6.5	Installing the fully automatic oven cleaning system	52
6.5.1	Components of Fully Automatic Oven Cleaning System	52
6.5.2	Connecting the Fully Automatic Cleaning System	54
6.6	Installing the Grease Collection Canister	55
6.6.1	Connecting the Grease Collection Canister	55
7	Placing into operation	57
7.1	Working Safely When Putting the Unit Into Operation	57
7.2	Procedure for Placing the Unit into Operation	58
7.3	Measuring unit gaps	60
8	Removing from Service and Disposal	61
8.1	Removing from Service and Disposal	61
9	Technical data	62
9.1	Dimensions and weights	62
9.2	Maximum permissible loading weight	63
9.3	EB/ES Electrical Supply	64
9.4	GB/GS Electrical Supply	65
9.5	Gas Characteristic Values for Natural Gas (USA), Propane (USA)	65
9.6	Heat loss	65
9.7	Water connection	66
9.8	Water quality	66
9.9	Water consumption during cooking and cleaning	67
10	Connection drawings	68
10.1	Convothem maxx pro 20.10 electrical unit	68
10.2	Convothem maxx pro 20.10 gas unit boiler	70
10.3	Convothem maxx pro 20.10 gas unit water injection	72
10.4	Convothem maxx pro 20.20 electrical unit	74
10.5	Convothem maxx pro 20.20 gas unit boiler	76
10.6	Convothem maxx pro 20.20 gas unit water injection	78

1 General

1.1 Environmental Protection

Policy statement

Our customers' expectations, the legal regulations and standards we have to follow, and our company's reputation are what drives the quality and service behind all our products.

Our environmental management policy is not only designed to ensure that we are always in full compliance with all environmental laws and regulations, but also reflects our commitment to the environment and to continuously improving our performance in this field.

In order to ensure that we meet all of our environmental goals while maintaining the high quality of our products, and that things stay this way, we have developed a quality and environmental management system.

This system meets the requirements set forth in ISO 9001:2015 and ISO 14001:2015.

Environmental protection measures

The following measures apply to this product:

- Uses fully compostable packing products
- Uses RoHS-compliant products
- Complies with the REACH regulation
- Recommends and uses biodegradable cleaning agents
- E-waste recycling
- Environmentally friendly disposal of old units through the manufacturer

Join us in our commitment to protecting the environment!

1.2 Identifying Your Combi Oven

Nameplate location

The nameplate is found on the left side of the combi oven.

Nameplate layout and structure for electrical units

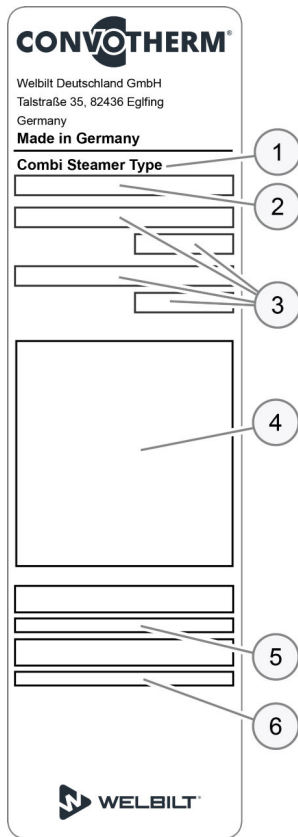

No.	Designation	
1	Unit name Combi Steamer	
2	Trade name	
	Letters	Meaning
	C4	Convotherm CmxPro product line
	eT	easyTouch controls
	eD	easyDial controls
	xx.yy numbers	Unit size
	EB	Electrical units with boiler
	ES	Electrical units with water injection
	-N	On units with NSF certification
3	Electrical specifications	
4	Marks	
5	Serial number	
	Letters	Meaning
	Heating method	Electrical unit (V)
	Steam generation method	<ul style="list-style-type: none"> ▪ Sprayer (S) ▪ Boiler (B)
	Unit size	<ul style="list-style-type: none"> ▪ 20.10 (6) ▪ 20.20 (7)
	Year of manufacture	<ul style="list-style-type: none"> ▪ 2023 (23) ▪ 2024 (24) ▪ ...
	Month of manufacture	<ul style="list-style-type: none"> ▪ January (01) ▪ February (02) ▪ March (03) ▪ ...
	Consecutive number	4-digit
6	Item number	

Nameplate layout and structure for gas units

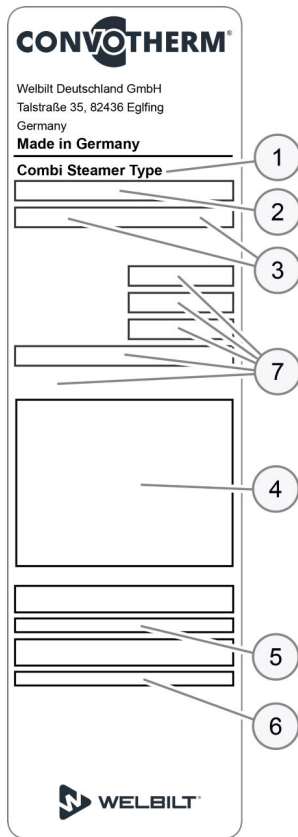

No.	Designation
1	Unit name Combi Steamer
2	Trade name
	Letters Meaning
	C4 Convotherm CmxPro product line
	eT easyTouch controls
	eD easyDial controls
	xx.yy numbers Unit size
	GB Gas unit with boiler
	GS Gas unit with water injection
	-N On units with NSF certification
3	Electrical specifications
4	Marks
5	Serial number
	Letters Meaning
	Heating method Gas unit (W)
	Steam generation method
	▪ Sprayer (S)
	▪ Boiler (B)
	Unit size
	▪ 20.10 (6)
	▪ 20.20 (7)
	Year of manufacture
	▪ 2023 (23)
	▪ 2024 (24)
	▪ ...
	Month of manufacture
	▪ January (01)
	▪ February (02)
	▪ March (03)
	▪ ...
	Consecutive number 4-digit
6	Item number
7	Gas specifications

1.3 Customer Documentation Structure

Unit documentation parts

Document type	Contents
Installation manual	<ul style="list-style-type: none"> ▪ Describes how to transport, set up, install, and put the unit into operation ▪ Goes over all the hazards involved in the various installation activities and how to prevent and/or counter them ▪ Contains technical specifications
Operating manual	<ul style="list-style-type: none"> ▪ Describes the work sequences and operating steps when cooking and cleaning ▪ Includes the maintenance schedule and troubleshooting information ▪ Goes over all the hazards involved when operating the unit and how to prevent and/or counter them
Operating instructions	<ul style="list-style-type: none"> ▪ Describes the unit's user interface ▪ Includes the instructions for using the software

Documentation for accessories

For information on how to install accessories (e.g., recoil hand shower, hood), please refer to the corresponding instructions for accessories.

1.4 About This Installation Manual

Target groups

Name of target group	Tasks
Person placing the unit into operation (service technician)	<ul style="list-style-type: none"> ▪ Responsible overall for placing the combi oven into operation ▪ Briefing the user
Storemanager Person authorized to give orders in the kitchen area	<ul style="list-style-type: none"> ▪ Briefed on all of the combi oven's safety-relevant functions, mechanisms, and devices by the person placing the unit into operation ▪ Shown how the unit is operated by the person placing the unit into operation ▪ If necessary, helping out as directed with transportation within the facilities and with setting up the unit
Mover	Transporting the unit within the facilities
Service technician	<ul style="list-style-type: none"> ▪ Setting up the unit ▪ Installing the network connection ▪ Installing the fully automatic oven cleaning system ▪ Placing the unit into operation and removing it from service
Electrician	<ul style="list-style-type: none"> ▪ Connecting the unit to the electrical connection at the facilities ▪ Uninstalling electrical connections
Water and wastewater installer	<ul style="list-style-type: none"> ▪ Connecting the unit to the water connection at the facilities ▪ Uninstalling water connections ▪ Connecting the unit to the drain connection at the facilities ▪ Uninstalling the drain connection
Gas technician	Installing and uninstalling gas connections

Decimal mark used

In order to ensure that all numbers can be properly understood internationally, a decimal point is always used.

1.5 Safety Information That Must Be Read without Exception

Safety information found in the documentation for the customer

Only the installation manual and operating manual provide safety information for the combi oven.

The installation manual provides safety information for the transportation, setup, installation, placing-into-operation, and removal-from-service tasks it describes.

The operating manual provides safety information for the cooking, cleaning, and maintenance tasks it describes.

When using the operating instructions, the operating manual or installation manual should always be consulted in order to obtain the relevant safety information. When performing activities that go beyond simply using the software, the safety information in the operating manual and installation manual must always be observed.

Parts of this document that must be read without exception

Failure to take the information in this document into account may result in death, injury, or property damage.

In order to ensure their safety and the safety of others, everyone working with/on the combi oven must read and understand the following parts of this document before starting any work:

- The 'For Your Safety' on page 15 section
- The sections describing the work that will be carried out

Danger symbol

Danger symbol

Meaning



Used to warn of potential injury. Observe all the precautionary statements following this symbol in order to avoid injury or death.

Precautionary statements

The precautionary statements in this manual are categorized using the following hazard levels:

Hazard level	Consequences	Likelihood
DANGER	Death / severe injury (irreversible)	Imminent
WARNING	Death / severe injury (irreversible)	Potential
CAUTION	Minor injury (reversible)	Potential
NOTICE	Property damage	Potential

2 Configuration and Functions

2.1 The Combi Oven's Configuration and Functions

Parts and functions

The figure below shows a size 20.20 gas unit as an example representing all models:

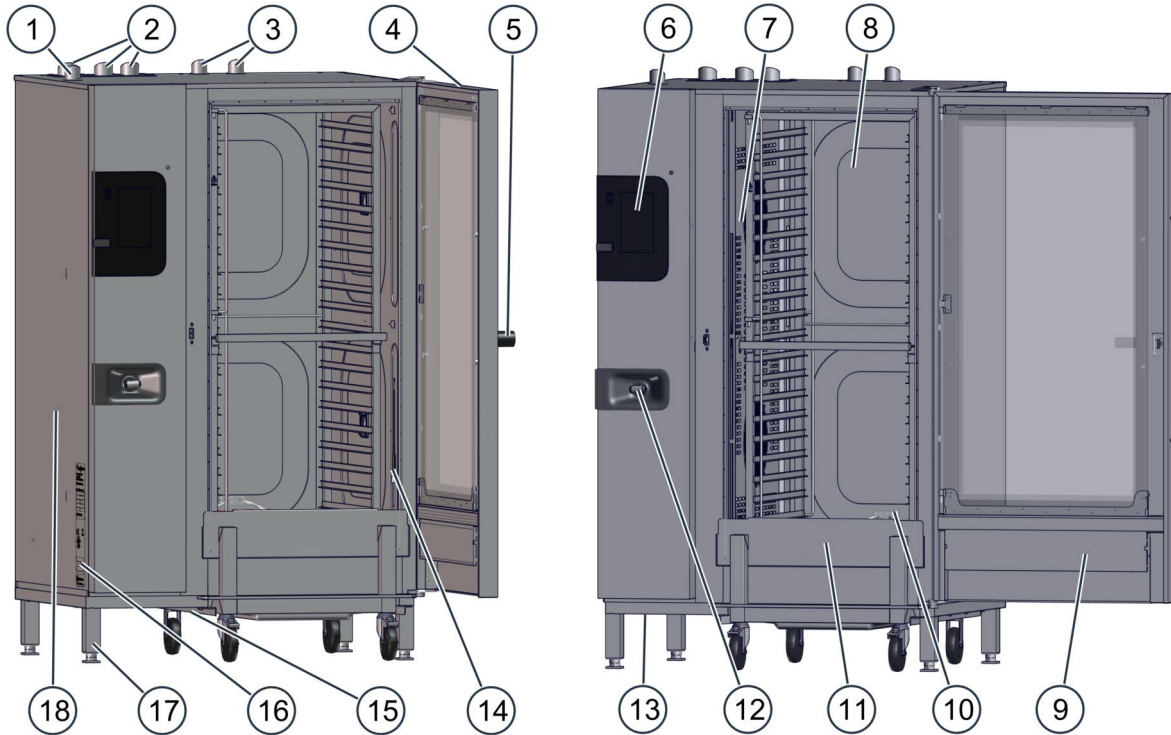

No.	Designation	Function
1	Ventilation port	<ul style="list-style-type: none"> Draws in ambient air in order to remove moisture from the oven cavity Compensates for pressure fluctuations inside the oven cavity
2	Exhaust outlet (gas units only)	Discharges hot exhaust gases
3	Air vent	Lets hot steam escape
4	Unit door	<ul style="list-style-type: none"> Seals the oven cavity When opened, it can be slid backwards along the unit's side in order to save space ('disappearing door') (optional)
5	Door handle	<ul style="list-style-type: none"> Used to open and close the unit door Venting position for opening the unit safely Antibacterial material with silver ions ("HygieniCare")
6	Operating panel	<ul style="list-style-type: none"> Used to operate the unit Antibacterial ("HygieniCare")
7	Suction panel	<ul style="list-style-type: none"> Used to distribute heat uniformly within the oven cavity Separates the fan compartment from the oven cavity
8	Oven cavity	Is where food is placed while it is being cooked
9	Integrated preheat bridge in unit door	Works as a safety element during pre-heating and reduces energy losses
10	Smoker heater (ConvoSmoke only)	Used to heat the smoker drawer

No.	Designation	Function
11	Loading trolley	Used to hold standard-size bakeware
12	Recoil hand shower (not included in certain units)	<ul style="list-style-type: none"> Meant exclusively for rinsing the oven cavity with water Is retracted automatically into its holder after being used Antibacterial ("HygieniCare")
13	Vents at the bottom of the unit	<ul style="list-style-type: none"> Used to ventilate the unit Must not be blocked
14	Core temperature probe, sous vide probe (optional)	<ul style="list-style-type: none"> Used to measure the food's internal temperature Available as an internal version that is permanently connected inside the oven and/or as an external version that can be temporarily connected
15	Floor lighting	Used to visualize the operating mode: <ul style="list-style-type: none"> Illuminated green: Cooking Blinking green: Cooking completed Yellow: Oven cavity is preheating or door is open Red: Combi oven malfunction
16	Nameplate	Used to identify the unit
17	Unit feet	Are height-adjustable so as to make it possible to level the unit
18	Side panel	Covers the unit's wiring compartment

Parts and functions for special locking feature (security model only)

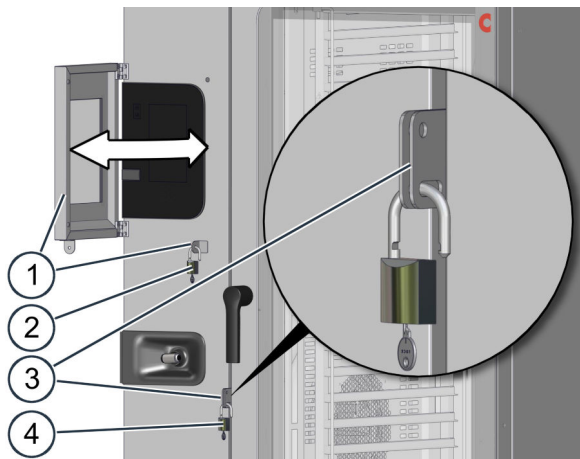

No.	Designation	Function
1	Lockable operating panel cover	The cover can be swung in and secured onto the unit case so that it covers the operating panel, preventing unauthorized users from operating the combi oven.
2	Padlock	<ul style="list-style-type: none"> Used to secure the operating panel cover onto the unit case Not included
3	Unit door hasp	Features two different slots that can be used to lock the unit door in order to prevent unauthorized users from opening and closing it Unit door action: <ul style="list-style-type: none"> If the unit door is locked using the upper slot, the door will always be fully closed. If the unit door is locked using the lower slot, it will be possible to open the door all the way to the cracked-open position
4	Padlock	<ul style="list-style-type: none"> Used to secure the unit door onto the unit case Not included

Material

The unit's inner and outer parts are made of stainless steel.

2.2 Operating Panel Layout and Functions

Control panel layout and parts in easyTouch

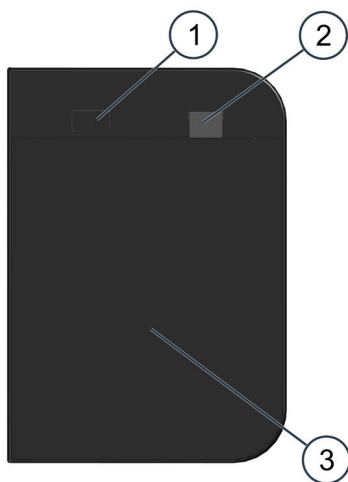

No.	Designation	Function
1	Unit ON/OFF switch	Used to turn the combi oven on and off
2	USB port	Used to plug in a USB stick
3	Full-touch display	The unit's central control interface <ul style="list-style-type: none"> ▪ Used by touching the icons on the full-touch display ▪ Status indicators

Operating panel layout and parts in easyDial

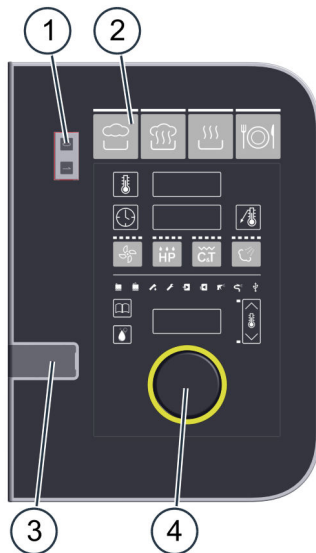

No.	Designation	Function
1	Unit ON/OFF switch	Used to turn the combi oven on and off
2	Control panel	The unit's central control interface <ul style="list-style-type: none"> ▪ Buttons used to enter cooking programs ▪ Displays used to indicate configured values ▪ Prompt indicators for the operator
3	USB port	Used to plug in a USB stick
4	C-Dial	Used to set cooking parameters by turning and pressing the encoder.

3 For Your Safety

Purpose of this section

The purpose of this section is to provide you with all the information you will need in order to safely work with/on the combi oven without putting yourself and others at risk.

Read this section very carefully!

3.1 Basic Safety Instructions

Purpose of these instructions

The purpose of these instructions is to ensure that everyone working with and on the combi oven will be fully aware of all the risks, hazards, and safety requirements involved and will observe the warnings in the operating manual and on the combi oven. Failure to follow these instructions may result in death, injury, or property damage.

Customer documentation manuals

Follow the instructions below:

- Fully read the 'For Your Safety' section, as well as the section that applies to the way you will be interacting with the combi oven.
- Keep the customer documentation manuals handy at all times so that you can look up any required information.
- If you transfer the combi oven to a new owner, make sure to give the new owner the customer documentation manuals as well.

Basic rules for installation

The unit must be installed in compliance with all national and state laws and regulations, with all applicable local requirements and regulations set forth by the relevant local utility companies and authorities, and with all other relevant regulations and standards.

These include, but are not limited to:

- The National Electrical Code, ANSI/NFPA 70 (current edition)
- The Canadian Electrical Code, CSA C22.2
- National Fuel Gas Code, ANSI Z223.1 /NFPA 54 (latest version)
- Natural Gas and Propane Installation Code, CSA B149.1
- The Food Code and Food Service Sanitation Manual published by the Food and Drug Administration (FDA) (current editions)
- Latest edition of the International Plumbing Code published by the International Code Council (ICC) or the Uniform Plumbing Code published by the International Association of Plumbing and Mechanical Officials (IAPMO)
- The standards published by the National Sanitation Foundation (NSF)
- All local fire protection and occupational health and safety regulations

Working with/on the combi oven

Follow the instructions below:

- Only people who meet all the requirements specified in this operating manual should be allowed to use and otherwise work with/on the combi oven.
- Only use the combi oven for its intended use as described in this manual. Never, under any circumstance, use the combi oven for other purposes, even if they seem obvious.
- Observe all the safety measures specified in this operating manual and on the combi oven. This applies especially to wearing the required personal protective equipment.
- Make sure to always stay in the specified work areas when working with/on the combi oven.
- Do not make any alterations to the combi oven. This includes removing components and adding components that have not been expressly approved. Above all, however, make sure not to disable any safety devices or guards.

3.2 Your Combi Oven's Intended Use

Intended use

- The combi oven has been designed and built exclusively for cooking a variety of food in GN containers (e.g., Gastronorm containers, patisserie-size sheet pans). Steam, convection, and combi-steam (steam superheated without pressure) are used for this purpose.
- The food containers can be made of stainless steel, ceramic, plastic, aluminum, enameled steel, or glass. Glass food containers must not be damaged.
- The combi oven is intended exclusively for professional commercial use.

Limitations on use

The combi oven should not be used to heat up the following materials:

- Dry powders or granular products
- Readily flammable substances or objects with a flashpoint lower than 518 °F, such as readily flammable oils, fats, plastics, cleaning agents, and liquids containing alcohol.
- Food in sealed cans

Staff requirements

- The combi oven must be run and installed exclusively by staff meeting the specified requirements. For the corresponding training and qualifications requirements, please refer to 'Staff and Work Area Requirements' on page 24.
- All staff must be familiar with the risks, hazards, and rules involved in handling heavy loads.

Requirements concerning the combi oven's functional capability

- The combi oven should only be used if all safety devices and guards are present, working properly, and correctly locked in place.
- All manufacturer specifications concerning how to run and service the combi oven must be observed.
- The load placed inside the combi oven must never exceed the maximum permissible loading weight; please refer to 'Technical Data' on page 62.

Requirements concerning the combi oven's surroundings

Required combi oven surroundings

- Ambient temperature between 40 °F and 95 °F
- No toxic or potentially explosive atmospheres
- Do not use or store gasoline or other flammable vapors, gases, or liquids in the vicinity of a combi oven
- Dry kitchen floor in order to reduce the risk of accidents occurring

Required installation location characteristics

- NO fire alarms or sprinkler system directly above the unit
- NO flammable materials, gases, or liquids above, on, under, or close to the unit

Limitations on use

- When used outdoors, the unit must be protected from rain and wind
- Do NOT shift or move the unit once it has been installed or during operation
- Before moving the unit, the 3rd foot at the front must be turned in and removed by unscrewing.

Prerequisites for cleaning

- Only use the cleaning agents approved by the manufacturer.
- Only use the cleaning tools specified by the manufacturer; please refer to 'Cleaning schedule' in the operating manual.
- Do NOT use a pressure washer to clean the unit.
- Do NOT use a water jet to clean the outside of the unit. Do not use the recoil hand shower or an external water jet for anything other than cleaning the oven cavity.
- Do NOT use bases or acids to clean the combi oven and make sure it is not exposed to acid fumes. The only exception is when the oven cavity is descaled by an authorized service company following the manufacturer's instructions.

3.3 Warning Labels on the Combi Oven





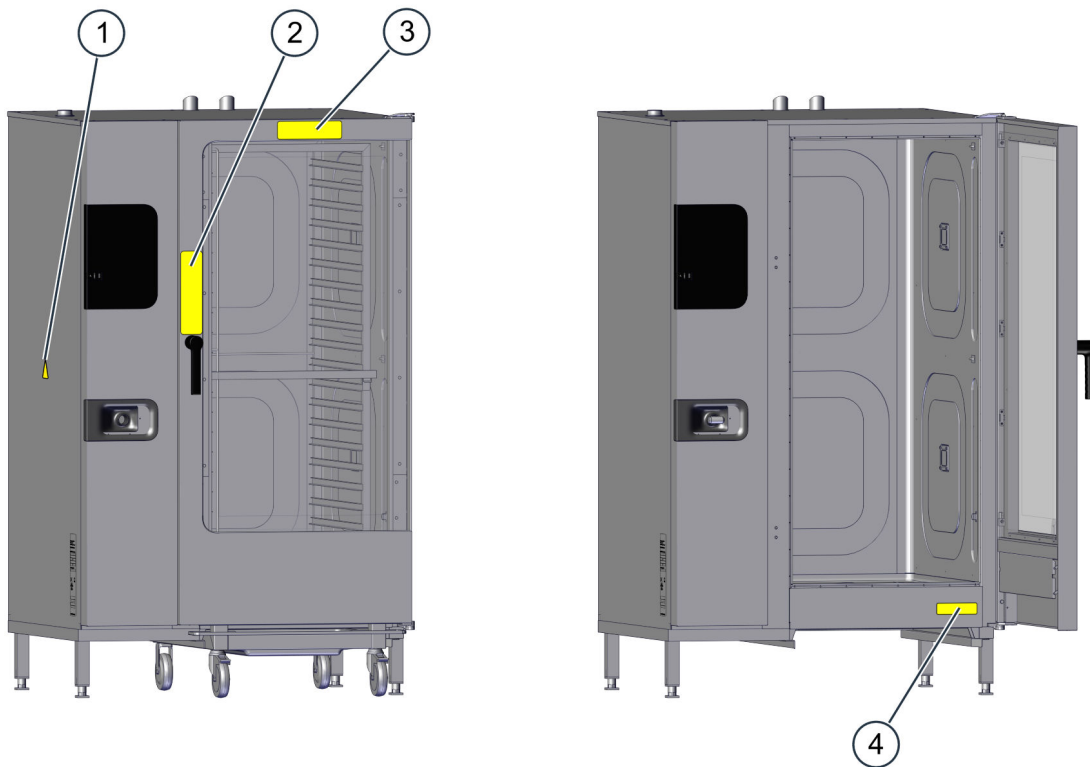

Warning label locations on the unit

The figure below shows a size 20.20 electrical combi oven used as an example representing all floor-standing models:

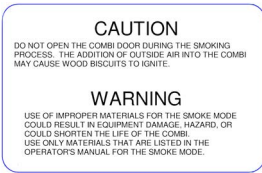

Required warning labels on the unit

The following warning labels must always be clearly visible on the combi oven at the locations shown in the previous figure.

Location	Warning label	Description
1 and 4		<p>WARNING</p> <p>To reduce the risk of electric shock, do not remove or open cover. No user serviceable parts inside. Refer servicing to qualified personnel. Disconnect power supply before servicing.</p> <p>AVERTISSEMENT</p> <p>Afin de réduire le risque d'électrocution, ne pas retirer ou ouvrir le capot. Aucune pièce réparable ne se trouve à l'intérieur. Confier le dépannage à du personnel qualifié. Débrancher l'alimentation électrique avant réparation.</p>
2		<p>Hot steam warning</p> <p>There is a risk of scalding posed by the hot steam coming out when the unit door is opened.</p>
2		<p>Standard model</p> <p>Hot liquid warning</p> <p>Risk of scalding when liquid food is spilled. This hazard exists when liquids, or food that becomes liquefied during cooking, are placed on the upper shelf levels. Do not use shelf levels located above your field of view to hold liquids or food that will become liquefied.</p>
2		<p>Bakery model</p> <p>Hazard posed by hot food and hot bakeware</p> <p>Hot food and hot bakeware will pose a burn hazard if the bakeware falls off the shelf levels or if food slides off bakeware that is being held in an inclined position. This hazard will be particularly acute in the case of shelf levels located above the operator's field of view.</p>
3		<p>Only with ConvoSmoke:</p> <p>CAUTION</p> <p>Do not open combi door during smoking. Outside air entering the combi may cause wood bisquettes to ignite.</p> <p>WARNING</p> <p>The use of improper materials for smoke mode may result in equipment damage or hazards or may shorten the life of the combi. Only use materials listed for smoke mode in the operator's manual.</p>
3		<p>CAUTION</p> <p>Surface(s) and Handle(s) may be hot.</p> <p>ATTENTION</p> <p>Surface(s) et poignée(s) chaudes</p>

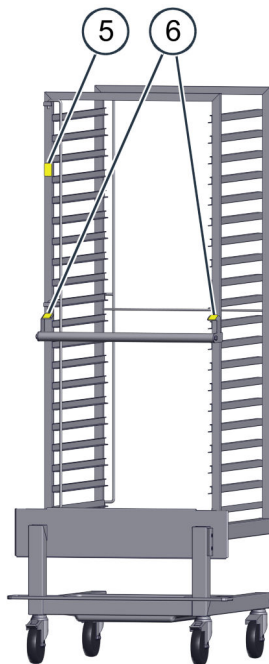

Warning label locations on the loading trolley

Loading trolley



Required warning labels on the loading trolley

The following warning labels must always be clearly visible on the loading trolley at the locations shown in the previous figures.

Location	Warning label	Description
5		Hot food, hot bakeware, and hot liquid warning Hot food and hot bakeware will pose a burn hazard if the bakeware falls off the shelf levels or if food slides off bakeware that is being held in an inclined position. This hazard will be particularly acute in the case of shelf levels located above the operator's field of view. Risk of scalding when liquid food is spilled. This hazard exists when liquids, or food that becomes liquefied during cooking, are placed on the upper shelf levels. Do not use shelf levels located above your field of view to hold liquids or food that will become liquefied.
5		Loading trolley tip-over hazard warning There is a risk of the loading trolley toppling over when being moved. Exercise extreme caution when moving the loading trolley. When moving the loading trolley, look out for obstacles and uneven surfaces.
6		Hot surface warning Hot surfaces on the loading trolley's handle pose a burn hazard.

3.4 Hazards posed by the unit

General rules when using the unit

The combi oven has been designed in such a way as to ensure that users will be protected from all hazards that can be reasonably prevented using design-based measures.

However, the combi oven's intended use entails a series of residual risks that will require you to take precautions in order to avoid them. The safety devices and guards on the unit may protect you from some of these risks to a certain extent. However, in order for the safety devices and guards to protect you, you must always make sure that they are in place and working properly.

Following is a description of these residual risks and what kinds of hazards they pose.

Leaking gas during placement into operation

Leaking gas can result in the following hazards during placement into operation:



Gas explosion hazard

When?

- Whenever the unit is moved and this causes leaks in connections
- Whenever the gas line is damaged

How can I avoid the hazard?

- ▷ Do not move the unit during operation or cleaning
- ▷ If you smell gas, take the appropriate steps; please refer to 'What to do if you smell gas' on page 57

Gas leaks during installation and placement into operation

Leaking gas can result in the following hazards as a result of the unit being improperly installed and removed from service:



Gas explosion hazard

When?

- Whenever there are leaks in gas lines
- Whenever the building's gas valve is opened before the connection is ready
- Whenever the gas is not shut off before starting work on gas units and/or gas installations for removal from service

How can I avoid the hazard?

- ▷ Make sure to only have certified gas installation engineers from an authorized service company work on the gas system
- ▷ Install a gas shut-off device close to the unit
- ▷ Always check all the connection points on components conveying gas for leaks after connecting the gas system and after performing any work on these components.
- ▷ Before placing the combi oven into operation, make sure that none of the specified connection points outside or inside the unit have any leaks.
- ▷ Shut off the gas before starting any removal-from-service work on gas units and/or gas system components

Risk of poisoning

Gas units can result in the following hazards in the kitchen:



Danger of carbon monoxide poisoning

Where?

- At the unit's installation location

How can I avoid the hazard?

- ▷ Check the exhaust gas readings and have a certified gas installation engineer from an authorized service company adjust the burner if necessary
- ▷ Make sure that there is a ventilation system that is fully functional and running. In addition, make sure to follow all the ventilation rules and practices specified by the gas installation engineer
- ▷ Do not block or otherwise obstruct the area below the unit
- ▷ Operate the unit in windless environments only

Moving heavy loads

During transportation and setup, the following hazards can be posed when moving heavy loads:



Risk of injury due to excessive exertion

When?

- Whenever moving or lifting the unit

How can I avoid the hazard?

- ▷ Use a forklift or pallet jack to place the unit at its installation location or to change its position or location
- ▷ Make sure that a sufficient number of people help correct the unit's position; do not lift or carry too much weight during the process (guideline: 30 lbs to a maximum of 120 lbs depending on age and sex).
- ▷ Comply with all occupational health and safety regulations that apply at the installation location
- ▷ Wear the required personal protective equipment

Loss of unit stability

During transportation and setup, the following hazards can be posed when moving the unit:



Crush hazard for all body parts if the unit falls down

When?

- Whenever moving or lifting the unit

How can I avoid the hazard?

- ▷ Use appropriate transportation equipment
- ▷ Transport equipment slowly and carefully and secure it in such a way that it cannot tip over
- ▷ Keep the unit's center of gravity in mind
- ▷ Avoid bumping into objects

Live parts

The unit can pose the following hazards during all installation work:



Risk of electric shock posed by live parts

Where?

- Under covers
- Under the operating panel
- On the power cable

How can I avoid the hazard?

- ▷ De-energize all connections
- ▷ Lock out and tag out all switches
- ▷ Wait 15 minutes so that the DC bus capacitors can discharge fully
- ▷ Make sure that all electrical connections are undamaged and properly connected
- ▷ Make sure that all legally required safety checks have been carried out.

Missing Grounding

The unit can pose the following hazards during all installation work:



Risk of electric shock posed by live parts

Where?

- On the unit and on neighboring metal parts
- On the unit and on neighboring metal accessories

How can I avoid the hazard?

- ▷ Before putting the unit into operation, make sure that it is bonded to an electrical ground system together with all metal accessories

Contact with cleaning agents

The unit can pose the following hazards during all installation work:



Skin, eye, and respiratory tract irritation hazard as a result of contact with cleaning agents and their vapors

When?

- When installing the cleaning system
- Whenever handling cleaning agent containers
- Whenever using aggressive cleaning agents

How can I avoid the hazard?

- ▷ Wear the required personal protective equipment
- ▷ Observe the instructions and warnings on the cleaning agent labels and in the relevant safety data sheets
- ▷ Use specified cleaning agents only

General hazards

In addition to the specified hazards, keep in mind all the general hazards that are found in kitchen environments. For more information, please refer to the 'For Your Safety' in the operating manual.

3.5 Safety Devices

Meaning

The combi oven features a series of safety devices and guards that protect the user from a variety of hazards. All safety devices and guards must be present, fully functional, and locked properly without exception when the combi oven is being used.

Location and functions

The figure below shows a size 20.20 electrical combi oven used as an example representing all floor-standing models:

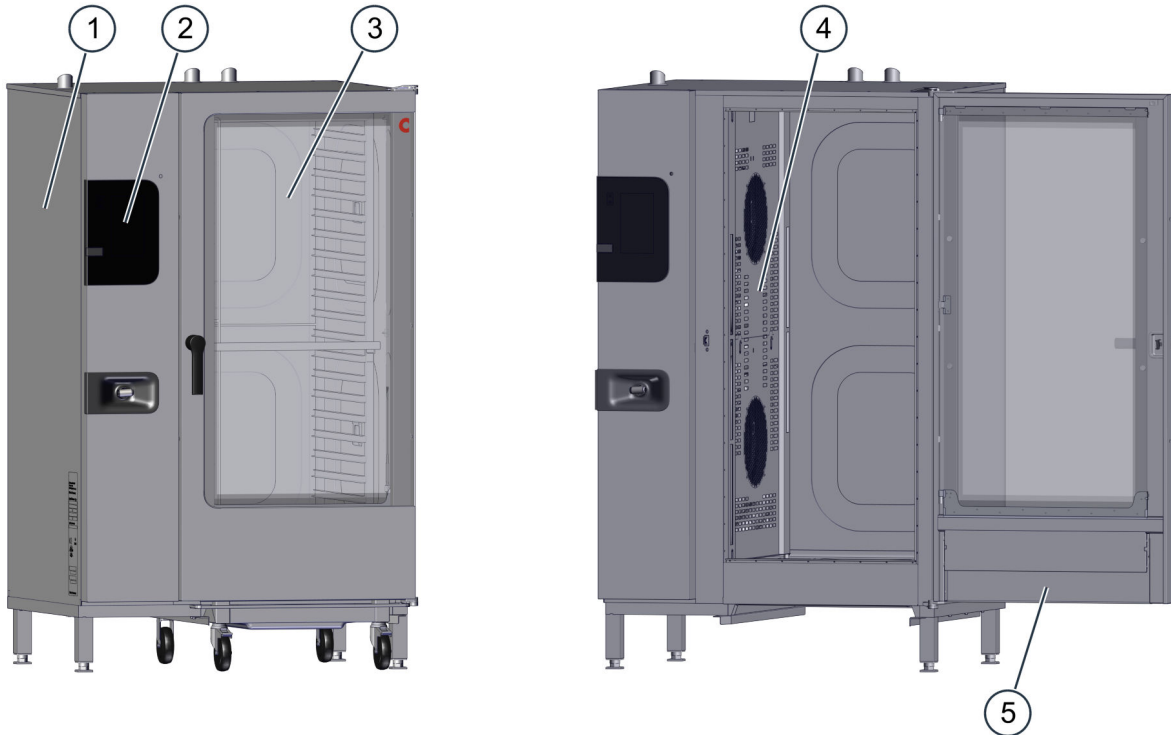

No.	Guard or safety device	Function	Check
1	Cover; can only be removed with tools	<ul style="list-style-type: none"> Prevents staff from accidentally touching live parts Prevents staff from reaching into the moving fan(s) inside the wiring compartment 	Check to make sure that the cover is in its proper place
2	Operating panel; can only be removed with tools	Prevents staff from accidentally touching live parts	Check to make sure that the operating panel is in its proper place
3	Unit door	Protects the operator and the surroundings from hot steam	Check the pane for scratches, cracks, and other damage on a regular basis and replace it if you detect any damage
4	Suction panel inside the oven cavity; can only be removed with tools	Prevents staff from reaching into the moving fan(s) and ensures proper heat distribution	Please refer to 'Releasing the Suction Panel and Locking it Back in Place' in the operating manual
5	Integrated preheat bridge in unit door	Prevents scalding caused by escaping steam if the loading trolley is not inside the unit during pre-heating	None
6 (not shown)	Safety thermostat <ul style="list-style-type: none"> Boiler Oven cavity 	Turns off the unit if the temperature exceeds the allowable limit	An error code will be output in the event of a fault (Contact a service company that is authorized to reset the safety thermostat)

No.	Guard or safety device	Function	Check
7 (installed by the customer)	Disconnecter	<ul style="list-style-type: none"> Installed close to the unit by the customer. Easily visible and accessible Used to de-energize the unit during cleaning, repairs, and maintenance work, as well as in hazardous situations 	Procedure: <ul style="list-style-type: none"> Trip the disconnecter Check that all three phases are de-energized at the unit's -X10 terminal block
8 (installed by the customer)	Gas shut-off device	<ul style="list-style-type: none"> Installed close to the unit by the customer; easily accessible and clearly marked Used to disconnect the unit from the gas supply during cleaning, repair, and maintenance work, as well as in hazardous situations 	Procedure: <ul style="list-style-type: none"> Close the gas shut-off device Make sure that the gas flow to the unit has been shut off

Safety measures

The following measures will contribute to greater safety:

Measure	Function	Check
Unit door solenoid switch (electrical door sensor)	<ul style="list-style-type: none"> Stops/turns off the following when the unit door is opened: <ul style="list-style-type: none"> Fan (will stop after a few seconds) Heating element Cleaning agent spraying in the fully automatic oven cleaning process Prompts the user to close the unit door 	Test the door solenoid switch with the combi oven at a low temperature Procedure: <ul style="list-style-type: none"> Fully open the unit door Press Start Result: The motor must not start running.
Unit door handle with cracked-open position	<ul style="list-style-type: none"> Prevents steam coming out from scalding the operator's face and hands 	With the combi oven at a low temperature, check the door positions as described in 'Safely Opening and Closing the Unit Door.'
Resuming after a power outage if there was cleaning agent inside the unit when the power went out	<ul style="list-style-type: none"> Starts the fully automatic oven cleaning process again, from a defined state, after a power outage 	None

3.6 Staff and Work Area Requirements

Staff requirements

The table below specifies the qualifications needed for each role. Provided that they have the required qualifications, a single person can take over more than one role if necessary.

Role	Required qualifications	Tasks
The person responsible for the combi oven	Is familiar with the rules involved in handling heavy loads	<ul style="list-style-type: none"> ▪ Briefed on all of the combi oven's safety-relevant functions, mechanisms, and devices by the person placing the unit into operation so that the information can be relayed to all the staff operating the unit ▪ Shown how the unit is operated by the person placing the unit into operation so that the information can be relayed to all the staff operating the unit ▪ If necessary, helping out as directed with transportation within the facilities and with setting up the unit
Mover	<ul style="list-style-type: none"> ▪ Trained in the use of forklifts and/or pallet jacks ▪ Is familiar with the rules involved in handling heavy loads 	Transporting the unit within the facilities
Service technician	<ul style="list-style-type: none"> ▪ Qualified staff from an authorized service company ▪ Has relevant technical training ▪ Has unit-specific training ▪ Is familiar with the rules involved in handling heavy loads ▪ Is able to assess whether the unit's power, water, drain, and network connections have been correctly set up. 	<ul style="list-style-type: none"> ▪ Setting up the unit ▪ Installing the fully automatic oven cleaning system ▪ Placing the unit into operation ▪ Removing the unit from service
Gas technician	<ul style="list-style-type: none"> ▪ Is a technician authorized by the gas provider ▪ Has relevant training ▪ Qualified staff from an authorized service company 	<ul style="list-style-type: none"> ▪ Connecting the unit to the gas connection at the facilities ▪ Uninstalling gas connections
Electrician	<ul style="list-style-type: none"> ▪ Qualified staff from an authorized service company ▪ Has relevant training ▪ Is a qualified electrician and is familiar with the technical standards that must be applied 	<ul style="list-style-type: none"> ▪ Connecting the unit to the electrical connection at the facilities ▪ Uninstalling electrical connections
Water and wastewater installer	<ul style="list-style-type: none"> ▪ Qualified staff from an authorized service company ▪ Has relevant training 	<ul style="list-style-type: none"> ▪ Connecting the unit to the water connection at the facilities ▪ Uninstalling water connections ▪ Connecting the unit to the drain connection at the facilities ▪ Uninstalling the drain connection
Person placing the unit into operation (service technician)	<ul style="list-style-type: none"> ▪ Is an employee from an authorized service company who is responsible overall for placing the unit into operation ▪ Has relevant technical training ▪ Has unit-specific training ▪ Is familiar with the rules involved in handling heavy loads ▪ Is able to assess whether the unit's power, water, and drain connections have been correctly set up and is familiar with the technical standards that must be applied. 	<ul style="list-style-type: none"> ▪ Briefing the company operating the unit or the responsible employee ▪ Checking all steps and conditions as per the checklists

Work areas during installation and placement into operation

During installation and placement into operation, the work area for staff will be the entire area occupied by the unit and its surroundings.

3.7  Personal protective equipment

Transportation and setup

Task	Tools used	Personal Protective Equipment
<ul style="list-style-type: none"> ▪ Transporting the unit within the facilities ▪ Setting up the unit at the installation location 	A forklift or pallet jack	<ul style="list-style-type: none"> ▪ Protective gloves ▪ Safety footwear ▪ A hard hat (e. g., when there are suspended loads, doing overhead work)

Installation, placing the unit into operation, and removing it from service

Task	Tools used	Personal Protective Equipment
Installing and uninstalling (removing from service) the following: <ul style="list-style-type: none"> ▪ Electrical connection ▪ Water connection ▪ Drain Connection ▪ Gas connection ▪ Automatic grease management 	Tools and equipment necessary for the specific task at hand	Work clothes and personal protective equipment based on the required task in accordance with country-specific regulations
Installing and uninstalling the fully automatic oven cleaning system	Tools and equipment necessary for the specific task at hand	The protective equipment required will depend on the cleaning agents being used, and may include: <ul style="list-style-type: none"> ▪ Respirator ▪ Safety eyewear ▪ Protective gloves ▪ Protective clothing/apron More detailed specifications regarding this equipment can be found in the EC safety data sheets for the cleaning agent(s) being used. For the latest version of these data sheets, please contact the manufacturer. Always follow the instructions and observe all warnings found on the labels used for the cleaning agent(s).
<ul style="list-style-type: none"> ▪ Placing the unit into operation ▪ Briefing the user 	Tools and equipment necessary for the specific task at hand	Wear appropriate work clothes for kitchen work as required by your country-specific standards and regulations, especially: <ul style="list-style-type: none"> ▪ Protective clothing ▪ Heat-resistant gloves ▪ Safety footwear
Removing the unit (removing it from service)	<ul style="list-style-type: none"> ▪ Carrying straps ▪ Appropriate lifting equipment ▪ A forklift or pallet jack 	<ul style="list-style-type: none"> ▪ Protective gloves ▪ Safety footwear ▪ A hard hat (e. g., when there are suspended loads, doing overhead work)

4 Transportation

4.1 Transporting the unit to the installation location

Required space during transportation

Make sure that the transportation route you will be following has enough space to accommodate the unit's entire width and height at all times.

The following table lists the dimensions for the units together with their packaging. This list can be used to figure out the required minimum door width and height required in order to be able to get the unit to its intended installation location:

		20.10	20.20
Width	[in]	46.7	56.3
Height	[in]	85.0	85.0
Depth	[in]	39.0	46.9

Load capacity for transportation

Make sure that the transportation equipment you will be using is able to handle the loads it will be transporting.

To determine the minimum load capacity that the transportation equipment must have, check the unit's weight, including its packaging, in the 'Technical Data' on page 62 section.

Transporting the unit to the installation location for the first time

Observe the following when transporting the unit:

- Always use a pallet to transport the unit.
 - Always keep the unit upright when moving it.
 - Use a pallet jack or forklift to lift the unit.
 - Make sure that the 3rd foot at the front is only mounted after setup at the installation location. If moved with the 3rd foot at the front, there is a risk that the unit case could be bent.
 - Transport the unit slowly and carefully and secure it in such a way that it cannot tip over. Make sure not to bump into the unit.
- Avoid uneven transportation routes and steep inclinations.

4.2 Preparing for Unpacking

Preparing for unpacking

Observe the following before unpacking the unit:

- Check the outer packaging for damage.
- Take the supplemental sheet with unpacking instructions from the shipping documents.

4.3 Included equipment and parts

Unit and accessories

The unit scope consists of the following parts:

- One combi oven
- One loading trolley with included lock for lowest shelf level for ConvoSmoke
- Two G3/4" - 3/4" GHT adapters (preinstalled)
- Two 3/4" GHT water supply lines
- One 2" drain pipe rubber elbow
- One empty canister for pumped out grease (ConvoGrill)
- One connecting hose with attached canister screw closure for the grease collection canister (ConvoGrill)

Documents

The following documents are enclosed with the unit:

- One installation manual
- One operating manual (hardware)
- One operating instructions document (software)

5 Setup

5.1 Adjacent Systems

Handling exhaust air

During operation, the combi oven will produce heat and moisture, most of which will escape upwards into the ambient air in the form of hot steam coming through the air vent(s). Do not connect any lines or ducts directly to the combi oven's air vent(s)!

The manufacturer recommends removing this exhaust air from the combi oven's working area with a range hood or ventilated ceiling.

In order to prevent fire hazards and other structural issues, such as corrosion, mold, and/or a decrease in stability, there must be sufficient clearance between the top of the unit and the ceiling. This clearance must be determined by taking the following into account:

- The reference point for the minimum vertical clearance (refer to 'Installation Location Requirements' on page 29).
- The type of exhaust system being used
- The characteristics of the ceiling at the installation location

The combi oven must always be set up, installed, and operated in compliance with all applicable country-specific and local standards and regulations.

Handling exhaust gas from gas units

Exhaust gas with a temperature of up to 930 °F will escape into the ambient air through the exhaust outlet(s) at the top of the unit. Do not connect any lines or ducts directly to the combi oven's exhaust outlet(s) in order to divert this exhaust gas!

It is absolutely mandatory to use a ventilation system with a safety shutdown function in order to evacuate the exhaust gas.

In order to prevent fire hazards, there must not be any flammable materials above the unit, and there must be sufficient clearance between the top of the unit and the ceiling. This clearance must be determined by taking the following into account:

- The reference point for the minimum vertical clearance, refer to 'Installation Location Requirements' on page 29
- The type of exhaust system and exhaust gas extraction system being used
- The characteristics of the ceiling at the installation location

The combi oven must always be set up, installed, and operated in compliance with all applicable country-specific and local standards and regulations.

5.2 Installation location requirements

Meaning

This section provides information on how to choose a suitable installation location for the unit. Carefully check the intended installation location to make sure it is adequate before bringing the unit there and starting with the installation!

Setup standards and regulations

All national, state, and local standards and regulations concerning commercial kitchen operations must be complied with. These include, but are not limited to, the Food Code published by the Food and Drug Administration (FDA) (current edition) and the standards published by the National Sanitation Foundation (NSF).

The local rules and regulations that apply to the installation location, as defined by the relevant local authorities and utility companies, must be complied with.

▲ Rules for safely setting up the unit

In order to prevent hazards that may be posed by the installation location and by the unit's surroundings, follow the rules below:

- It must be possible to adhere to the operating conditions at all times. For these operating conditions, please refer to 'Requirements concerning the combi oven's surroundings'.
- The heat loss at hot surfaces poses a fire hazard. Accordingly, set up the unit in non-combustible environments only.
- There must not be any flammable materials, gases, or liquids at a distance of less than 18" from the sides of the unit (right, left, front, back) and 40" from the top of the unit. When choosing an installation location, make sure to observe this requirement together with the requirements in the 'Adjacent Systems' on page 29 section and the unit's minimum space requirements without exception!
- Substructures (tables, frames) and supporting surfaces (floors, bases, countertops) must be made of non-combustible materials and must not be coated or covered with any flammable materials (no fiberboard, no contact between flammable materials and the bottom of the unit). Likewise, there must not be any flammable materials on the undersides of these structures. The unit supporting surfaces on substructures of this type must project beyond the unit's base on all sides by 12" or more.
- The minimum distance from heat sources in the vicinity of the units is 20".
- The minimum distance that must be maintained between the unit and any deep fryers or open kettle fryers in the vicinity is as follows 63". The unit must be set up in such a way that liquids from the unit and from cooking processes will not be able to get to deep fryers and open kettle fryers under any circumstance.
- Do not set up the unit directly under a fire alarm or sprinkler system. The sensitivity of fire alarms and sprinkler systems must be adjusted in line with the amount of vapor and steam that the unit is expected to produce.
- The connection between the combi oven's drain pipe and the sewer system must be located outside the perimeter of the unit's base area. Due to potential wastewater vapors, there must not be a drain connection or open sewer line below the unit's base area.
- It must be possible to set up the unit at the installation location in such a way that it will not topple over or shift. All supporting surface requirements must be met.
- With its current configuration, the unit is not designed to be used in environments where it could be subjected to strong vibrations or mechanical shock (e.g., on vehicles or ships).

Supporting surface requirements

The supporting surface must have the following characteristics:

- The supporting surface must be flat and level.
- The supporting surface must be capable of bearing the unit's weight.

The unit's weight will be made up of the following depending on its specific model and equipment:

- The combi oven's empty weight
- Maximum permissible loading weight
- The maximum cleaning agent weight when the unit is equipped with a ConvoClean / ConvoClean+ system

Add the following individual weights to calculate the total unit weight:

		20.10	20.20
Individual weights			
The combi oven's empty weight	[lbs]	See the weight without packaging in 'Technical Data on page 62'	
Maximum permissible loading weight	[lbs]	220	397
Maximum weight of cleaning agents	[lbs]	44	44

Space required

In order to ensure that the combi oven will be used safely – especially when it comes to safely handling hot food –, it is necessary to keep a lot more free space in front of the units than is specified in the space requirements!

In order to determine the actual space required between the top of the combi oven and the ceiling, please consult the 'Adjacent Systems' on page 29 section.

Generally speaking, it is recommended to maintain large clearances between the units and the walls in order to make it easier for service staff to access the unit as needed.

Do not cover, obstruct, or block the following parts at the installation location (please refer to 'The Combi Oven's Configuration and Functions' on page 12 as well):

- The air vents and exhaust outlets at the top of the unit
- The dry air intake at the top of the unit
- The ventilation openings at the bottom of the unit

Required space for units with a right-hinged door – width and depth

The following diagrams, as well as the following table, show the space required by the unit for various installation and operating situations, as well as the minimum horizontal clearances required relative to adjacent walls and surfaces. The safety clearances on the left, right, and rear must be maintained without exception.

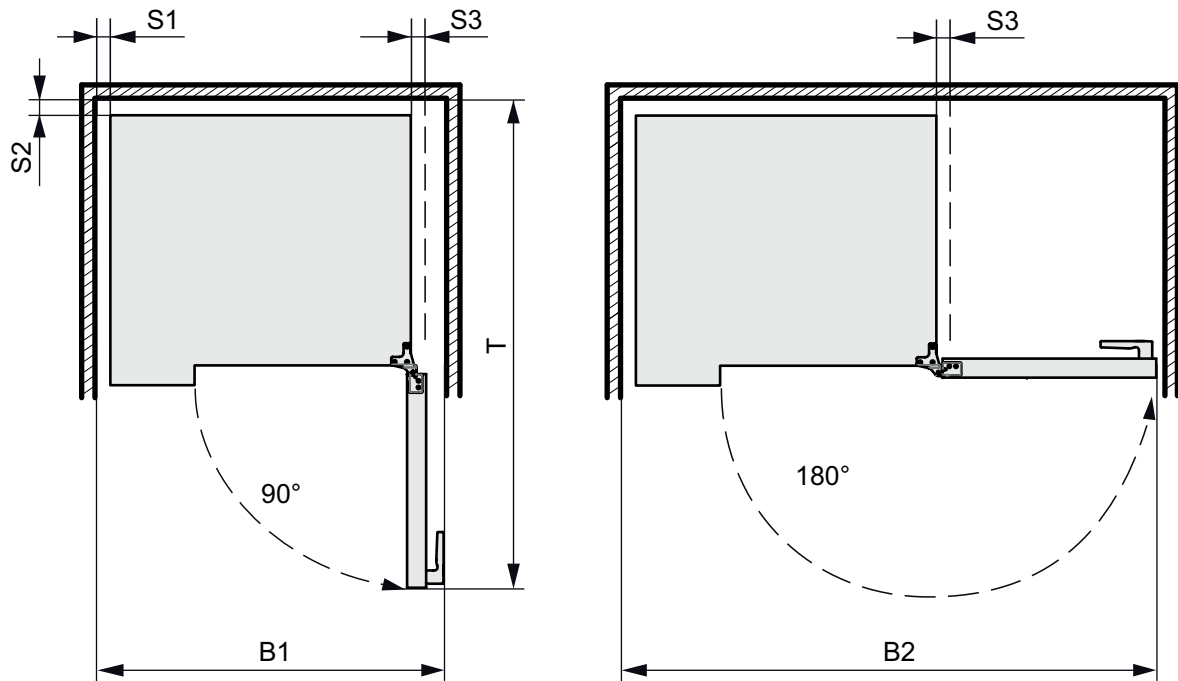

		20.10	20.20
Meaning			
B1	Required width when the unit door is open 90°	[in] 42	52
B2	Required width when the unit door is open 180°	[in] 61	77
T	Required depth when opening the unit door	[in] 56	72
S1	Safety clearance on left-hand side	[in] 2	2
S2	Rear safety clearance	[in] 2	2
S3	Safety clearance on right-hand side	[in] 2	2

Required space for units with a disappearing door – width and depth

The following diagrams, as well as the following table, show the space required by the unit for various installation and operating situations, as well as the minimum horizontal clearances required relative to adjacent walls and surfaces. The safety clearances on the left, right, and rear must be maintained without exception.

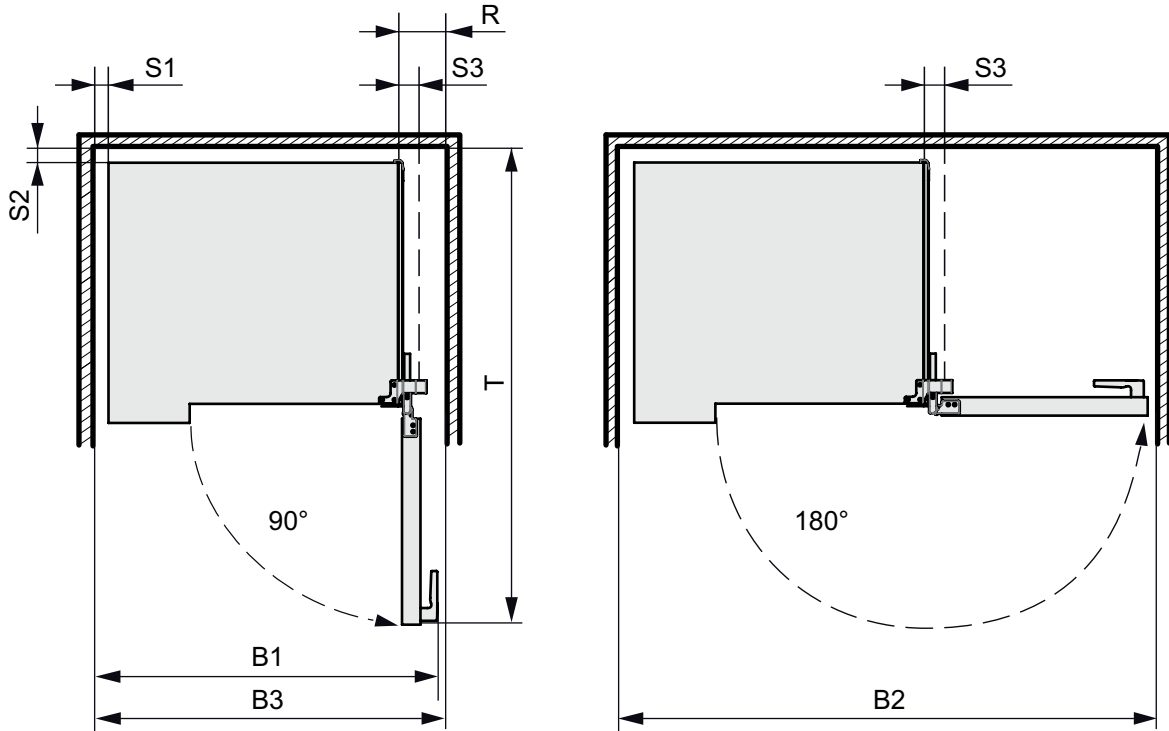

		20.10	20.20
Meaning			
B1	Required width when the unit door is open 90°	[in] 43	53
B2	Required width when the unit door is open 180°	[in] 61	79
B3	Required width when the disappearing door has been slid back	[in] 43	53
R	Required space on right-hand side when the disappearing door has been slid back	[in] 6	6
T	Required depth when opening the unit door	[in] 57	73
S1	Safety clearance on left-hand side	[in] 2	2
S2	Rear safety clearance	[in] 2	2
S3	Safety clearance on right-hand side	[in] 2	2

Required space – height

The figure below shows a size 20.20 combi oven used as an example representing all models:

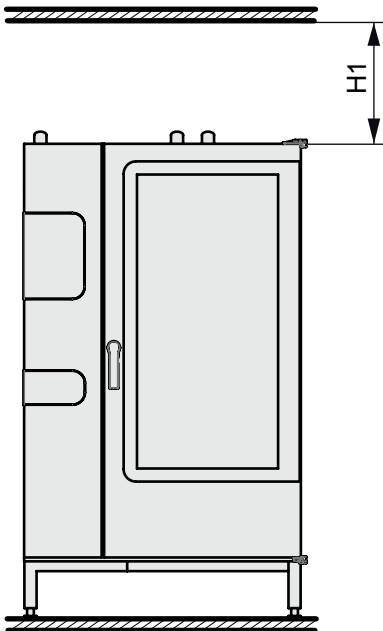

The service technician responsible for setting up the unit must take into account the ceiling's properties and any adjacent systems being used (air ventilation system, range hood) when determining the actual clearance required between the top of the unit and the ceiling. Vertical clearance H1 is only meant to serve as a reference point for the minimum vertical clearance.

		20.10	20.20
Meaning			
Electrical units			
H1	Reference point for minimum vertical clearance	[in] 20	20
Gas units			
H1	Reference point for minimum vertical clearance	[in] 39	39

5.3 Removing the unit from the pallet

⚠ Rules for safely lifting the unit

- Observe the following rules in order to prevent the unit from toppling over:
- The unit must be carefully lifted and secured in such a way that it will not tip over.
 - Observe the center of gravity.

Removing the unit from the pallet

1.

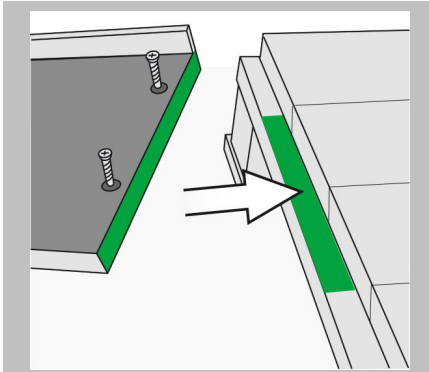

Place the guide rails, with the raised edge on the outside, on the green markings on one of the pallet's sides. Make sure that the ends of the guide rails are lying right against the side of the pallet so that the screws will engage the pallet's lip properly.

2.

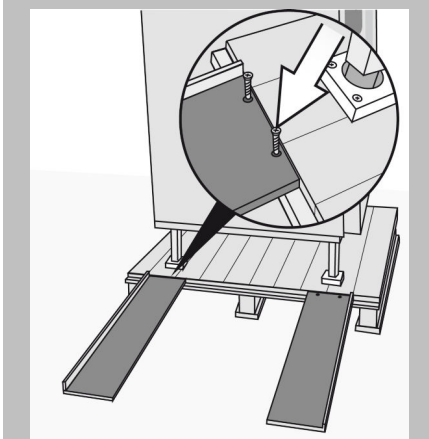

Screw the two guide rails together with the pallet.

3.

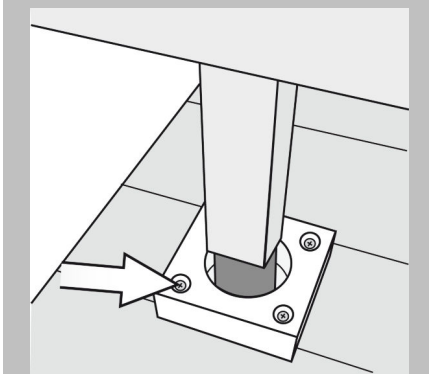

Remove all the screws from the sliding blocks.

4.

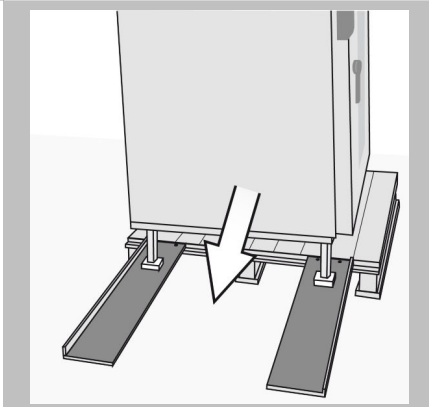

⚠ WARNING

Crush hazard if the unit topples over

- Before sliding the unit off the pallet, check to make sure that the guide rails are securely fastened to the pallet.
- Make sure that none of the unit's feet slip from the guide rails sideways.
- Exercise caution when the unit moves from the guide rails to the non-slip floor.

Use at least two people to slide the unit on the sliding blocks all the way across the guide rails and onto the floor all the way to the installation location.

5.

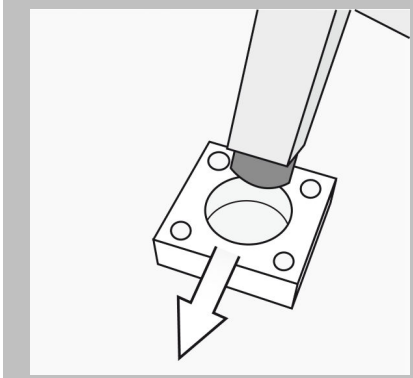

Slightly lift the combi oven and remove the sliding blocks.

6.

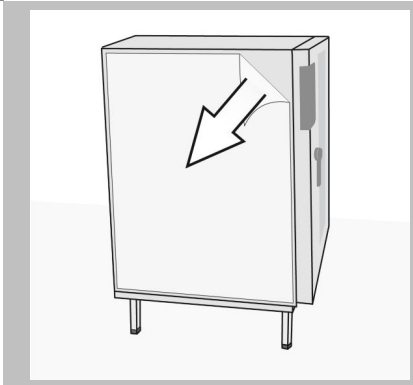

Carefully pull off the protective film on the combi oven while holding the housing wall with one hand.

5.4 Setting Up the Unit on the Floor

⚠ Rules for safely setting up the unit

Observe the following rules in order to ensure that the unit will have the required stability:

- It must be possible to set up the unit at the installation location in such a way that it will not topple over or shift. All supporting surface requirements must be met.
- It must be possible to move the loading trolley all the way to the oven cavity unobstructed on a horizontal surface.
- The unit must not be installed directly above a drainage channel.
- The 3rd foot at the front for stability and leveling must only be mounted after final positioning of the unit.

Setting up the unit

1.



Place the unit on the floor.

2.

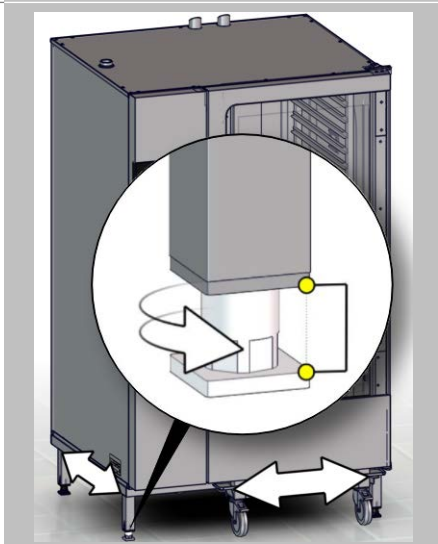

Align the unit horizontally using the height-adjustable feet. Use a spirit level to make sure that the unit is properly leveled. Make sure that the loading trolley can move without a problem into the unit and is in a horizontal position inside the unit.

6 Installation

6.1 Electrical installation

6.1.1 Planning the Electrical Installation

Meaning

It is crucial for the unit's electrical system to be carefully and correctly installed in order for the unit to run safely and without any problems. All the rules and specifications specified in this section, as well as the procedures described, must be followed to the letter.

⚠ Rules for safely installing the unit electrically

In order to prevent hazards related to improperly installed electrical connections, make sure to observe the following rules:

- The unit's case must be properly grounded as per generally accepted standards and practices and connected to an equipotential bonding system.
- The field installed conductors must be routed through a flexible conduit.
- While placing the unit into operation, check all electrical connections to make sure they have been routed properly and installed correctly.

Electrical installation standards and regulations

In order to prevent hazards related to improperly installed electrical connections, make sure to observe the following standards and regulations:

- The connection to the power supply must be installed in accordance with the National Electrical Code, ANSI/NFPA 70 (current edition); the Canadian Electrical Code, CSA C22.2; all other applicable national and state laws and regulations; and the local requirements set forth by the relevant local utility companies, trade associations, and authorities.

Equipment provided by the customer and electrical installation rules

The following table shows the equipment that must be provided by the customer and the rules that have to be followed when making the relevant electrical connections.

Equipment	Rules
Fuse	The unit must be fused and connected in accordance with all applicable local regulations and country-specific installation regulations.
Equipotential bonding	The unit must be connected to an equipotential bonding system. Equipotential bonding: An electrical connection that brings the frames of electrical equipment and other conductive parts to the same or approximately the same potential.
Disconnecter	An easily accessible all-pole power disconnection with a contact gap of at least 0.12" must be installed. The unit must be connected through this power disconnector. The power disconnection will then be used to de-energize the unit before performing cleaning, repair, and installation work.

Power supply

The field installed conductors must be routed through an oil-resistant, liquid-tight conduit. Moreover, the field installed conductors and the conduit must comply with all local requirements and regulations. A specific phase rotation direction or phase sequence is not required when connecting the unit.



6.1.2 Performing the Electrical Installation

Prerequisites

Check whether the following prerequisite is met:

- The unit's connection point has been de-energized and locked and tagged out.

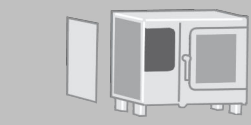
Checking the rating data and electrical connections

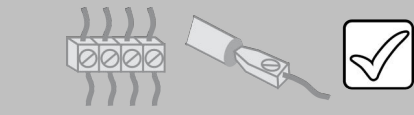
- | | | |
|----|---|--|
| 1. |  | <p>Remove the unit's side panel.
The circuit diagram and the spare parts list will be located inside the wiring compartment.</p> |
| 2. |  | <p>Check to make sure that the electrical rating data on the nameplate (please refer to 'Identifying Your Combi Oven' on page 7) matches the specifications in the circuit diagram and the characteristics of the building's electrical system. Do not connect the unit unless all specifications match.</p> |
| 3. |  | <p>Check all screw and crimp terminal connections on the unit.
The connections may have become loose during transportation.</p> |

Performing the Electrical Installation

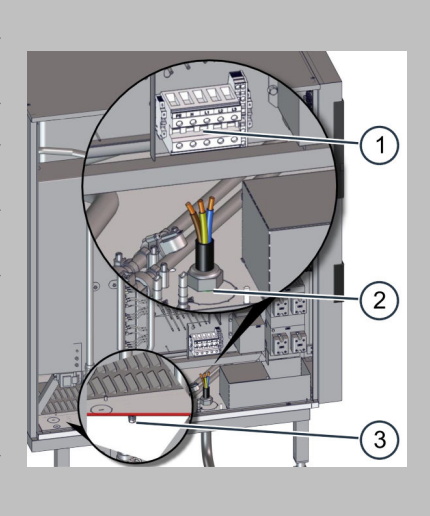
- | | | |
|----|---|--|
| 1. |  | <p>Remove the unit's side panel.</p> |
| 2. | | <p>Connect the unit to an electrical ground system at the intended connection point (3).</p> |
| 3. | | <p>Pull the field installed conductors through the conduit.</p> |
| 4. | | <p>Mechanically secure the conduit to the access opening (2) for the electrical connection.</p> |
| 5. | | <p>Use the field installed conductors to connect the unit to the power supply at terminal block -1X0 (1).</p> |
| 6. | | <p>For C4 ES/GS:
If necessary, reset the safety thermostat for the oven cavity.
For C4 EB/GB:
If necessary, reset the safety thermostats for the oven cavity and boiler.</p> |
| 7. | | <p>Put the unit's side panel in place and check that it is mounted properly.</p> |

6.1.3 Connecting the energy optimization system

Purpose of energy optimization system

You can connect the combi oven to an energy optimization system (e.g. SICOTRONIC). Energy optimization system compensate for peak loads that occur while your units are running and can help lower your electricity costs as a result.

Setting up the energy optimization system

Set up the energy optimization system as follows:

- Do not exceed the maximum cable length of 190" between the unit and the energy optimization system. If there is no other choice, the connection must go through a relay that is at a distance of 190" or less from the unit.
- The combi oven must be on without interruption for at least eight minutes, since this is the minimum time required in order to ensure that the cooking temperature setpoint will be reliably reached.
- The power interruption effected by the energy optimization system must not last longer than 30 seconds, as a longer interruption will result in uncertain cooking results.

When connecting the energy optimization system, observe the circuit diagram and follow the operating instructions for the system.

Required accessories

You will need the following accessories to connect the energy optimization system:

- Connection cable for energy optimization system
- M20 cable fitting
- Cable ties

Connecting the energy optimization system

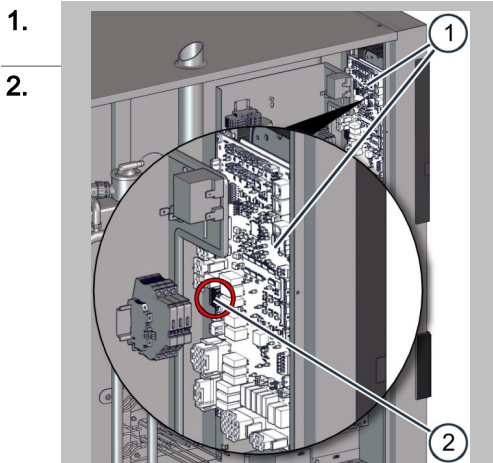

1. De-energize the energy optimizing system and the combi oven.

2. Remove the side panel from the combi oven in order to access terminal block -X37 (2) on the system interface board (SIB) (1) in the area behind the operating panel.

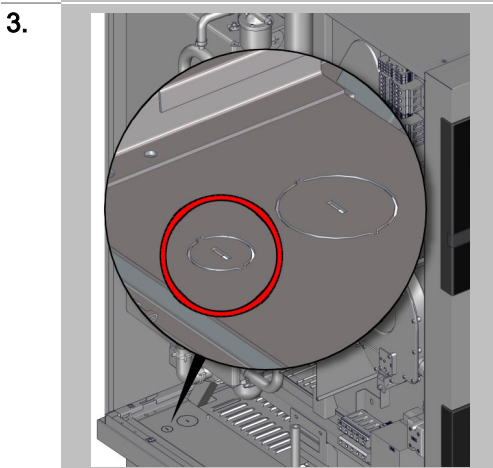

- 3.
- Remove the small pre-perforated knockout on the combi oven's bottom panel. The knockout's location is shown on the left.
 - Using the cable fitting, guide the energy optimization system's connection cable through the knockout and into the combi oven's wiring compartment.
 - Connect the connection cable to the SIB and secure it inside the wiring compartment, e.g., by using cable ties to secure it to the cable harnesses already inside the compartment.

4. Remove the jumper between terminals (B) and (C) on terminal block -X37 (2).

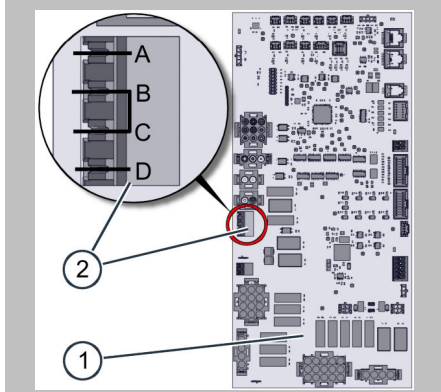

5. Connect terminals (A), (B), (C), and (D) on terminal block -X37 (2) to the energy optimization system.

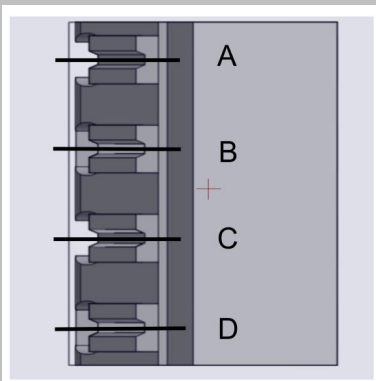

Terminal	Combi Oven	Energy optimization system
A	Phase (when the combi oven is turned on)	-
B	Phase (when the combi oven is turned on)	Electronic relay
C	The energy optimization system must connect heater enable terminals B and C to each other with electronic relays in order to allow heating	Electronic relay
D	Neutral	-

6. Put the combi oven's side panel back in place.

7. Place the combi oven and the energy optimization system into operation.



6.1.4 Connecting the Signal Tower

Signal tower purpose

If a signal tower is electronically connected to the combi oven, the tower will visually and acoustically indicate the combi oven's current operating state using acoustic signals and three indicator lights (green, yellow, red). This pilot device, which signals the combi oven's operating state, can be seen and heard across large distances.

Required accessories

The equipment included with the signal tower includes the following original accessories, which you will need in order to connect the signal tower to the combi oven:

- Connection cable (approx. 10.9 yards long) with an M12 connector
- NPS 2" gland grommet

You will also need the following additional accessories:

- Cable ties

Connecting the Signal Tower

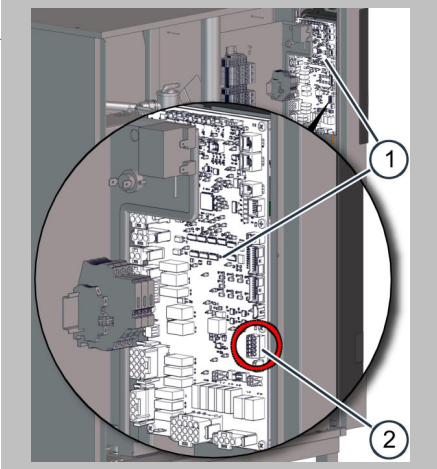
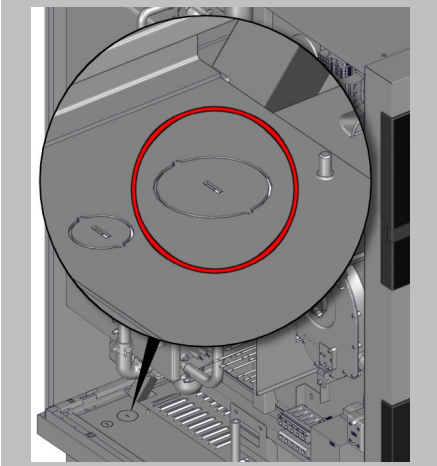
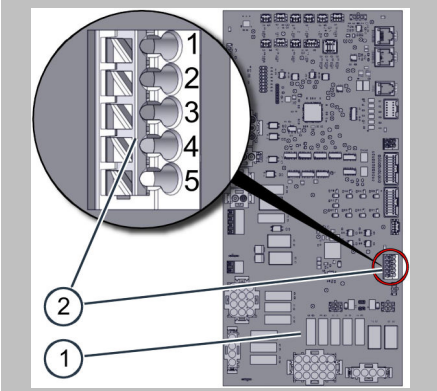
<p>1.</p>		<p>De-energize the combi oven.</p>																		
<p>2.</p>		<p>Remove the side panel from the combi oven in order to access terminal block X32 (2) on the system interface board (SIB) (1) in the area behind the operating panel.</p>																		
<p>3.</p>		<ul style="list-style-type: none"> ▪ Remove the large pre-perforated knockout on the combi oven's bottom panel. The knockout's location is shown on the left. ▪ Using the gland grommet, guide the signal tower's connection cable through the knockout and into the combi oven's wiring compartment. ▪ Connect the connection cable to the SIB and secure it inside the wiring compartment, e.g., by using cable ties to secure it to the cable harnesses already inside the compartment. 																		
<p>4.</p>		<p>Connect the signal tower's connection cable to the combi oven, observing the following pinout:</p> <table border="0" style="width: 100%; border-collapse: collapse;"> <thead> <tr> <th style="text-align: left;">Pin</th> <th style="text-align: left;">Signal</th> <th style="text-align: left;">Wire color</th> </tr> </thead> <tbody> <tr> <td>1</td> <td>GND</td> <td>BU (blue)</td> </tr> <tr> <td>2</td> <td>Signal: Buzzer</td> <td>GY (gray)</td> </tr> <tr> <td>3</td> <td>Signal: Red light</td> <td>BK (black)</td> </tr> <tr> <td>4</td> <td>Signal: Yellow light</td> <td>WH (white)</td> </tr> <tr> <td>5</td> <td>Signal: Green light</td> <td>BN (brown)</td> </tr> </tbody> </table>	Pin	Signal	Wire color	1	GND	BU (blue)	2	Signal: Buzzer	GY (gray)	3	Signal: Red light	BK (black)	4	Signal: Yellow light	WH (white)	5	Signal: Green light	BN (brown)
Pin	Signal	Wire color																		
1	GND	BU (blue)																		
2	Signal: Buzzer	GY (gray)																		
3	Signal: Red light	BK (black)																		
4	Signal: Yellow light	WH (white)																		
5	Signal: Green light	BN (brown)																		

- 5.
- 6.



Put the combi oven's side panel back in place.

Place the combi oven and the signal tower into operation.

6.1.5 Connecting the Water Treatment Filter Monitoring System

Water treatment filter monitoring system purpose

You can electrically connect the combi oven to the remote indicator for a connected water treatment filter. When you do so, the combi oven's software will monitor the water treatment filter's condition. The system will provide a warning when the filter's capacity is down to 10% and the water treatment filter needs to be replaced soon.

Required accessories

- Two-conductor, oil-resistant connection cable (approx. 80" long)
- NPS 2" gland grommet
- Cable ties

Connecting the Water Treatment Filter Monitoring System

- 1.
- 2.

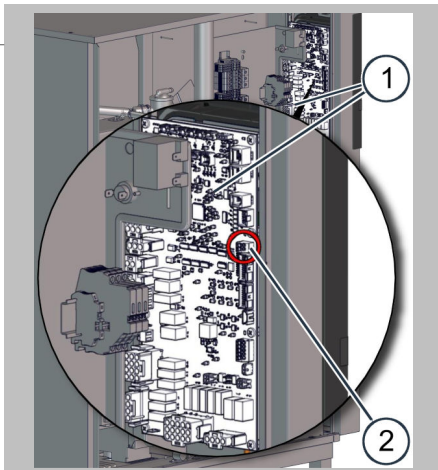

De-energize the combi oven.

Remove the side panel from the combi oven in order to access terminal block X33 (2) on the system interface board (SIB) (1) in the area behind the operating panel.

3.

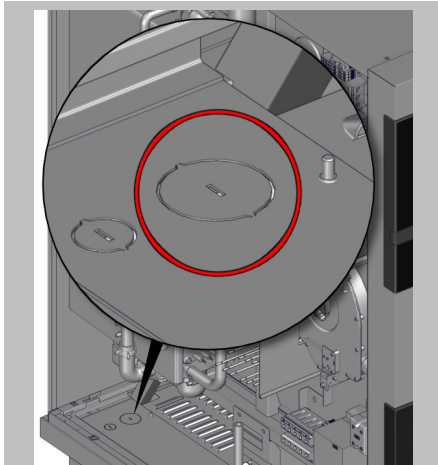

- Remove the large pre-perforated knockout on the combi oven's bottom panel. The knockout's location is shown on the left.
- Using the gland grommet, guide the water treatment filter monitoring system's connection cable through the knockout and into the combi oven's wiring compartment.
- Connect the connection cable to the SIB and secure it inside the wiring compartment, e.g., by using cable ties to secure it to the cable harnesses already inside the compartment.

4.

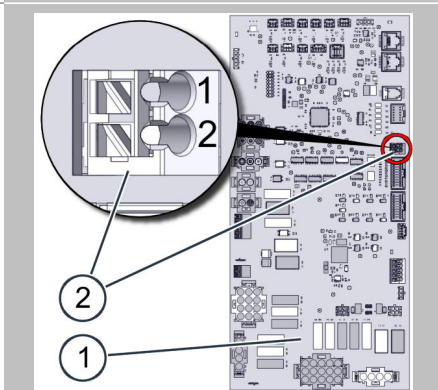

Connect the water treatment filter monitoring system's connection cable to the combi oven, observing the following pinout:

Pin	Signal
1	Signal
2	GND

5.



Put the combi oven's side panel back in place.

6.

Place the combi oven and the water treatment filter monitoring system into operation.

6.2 Gas Installation

6.2.1 Planning the Gas Installation

Rules for safely installing the unit's gas system

In order to prevent hazards related to improperly installed gas connections, make sure to observe the following rules:

- The combi oven is designed to work with a specific type of gas (check the unit's nameplate). In order to run the combi oven with other types of gas, it will first need to be retrofitted by qualified staff from an authorized service company.
- Always check all the connection points on components conveying gas for leaks after connecting the gas system and after performing any work on these components. Before placing the combi oven into operation, make sure that none of the specified connection points outside or inside the unit have any leaks.

Gas unit type

The combi oven belongs to the following gas unit type category:

Gas unit type	Meaning
B23	Open-flued gas appliances <ul style="list-style-type: none"> ▪ With a burner fan in front of the burner ▪ With no draft diverter

Equipment provided by the customer and gas installation rules

The following table shows the equipment that must be provided by the customer and the rules that have to be followed when making the relevant electrical connections:

Equipment	Rules
Fixed connection	The unit is designed for a permanent connection installed on-site. Gas connection location: point J in the connection drawing. The unit must be mechanically secured.
Gas shut-off device	A gas shut-off device must be installed close to the unit. This gas shut-off device must be easily accessible and positioned in such a way that it can be closed even in hazardous situations.
Pressure regulator	A pressure regulator must be installed if the supply flow pressure is too high.
All connection parts	All connection parts installed on-site must be inspected in compliance with all applicable local and country-specific regulations.

Ensuring that there is a proper combustion air supply

Based on the installation setup and the combi oven's output, all measures required in order to ensure that the unit will be supplied with sufficient combustion air should be taken in accordance with all applicable local regulations and standards. Make sure, as the gas technician responsible for the installation, that the unit will be supplied with sufficient combustion air.

Keep the following in mind:

- The required combustion air will depend on the connection rating – please refer to the 'exhaust gas volume' in the 'Technical Data' on page 62 section.

Ensuring that there is proper ventilation

The unit will produce combustion exhaust gases that need to be discharged into the open through an appropriate flue. Make sure to follow all the instructions and indications in the 'Adjacent Systems' section on page 29 without exception.

In order to prevent combustion exhaust gases that are harmful to health from reaching impermissible concentration levels, you, as the gas technician responsible for the installation, must ensure that the unit is installed in such a way that appropriate ventilation conditions for running the combi oven will always be guaranteed.

Exhaust gas temperature

The undiluted exhaust gas may reach temperatures of up to 930 °F.

Comply with all fire safety regulations.

6.2.2 Forced air burner positions

Forced air burner location

The figure below shows a size 20.20 combi oven with a boiler used as an example representing all size 20.10 and 20.20: gas units:

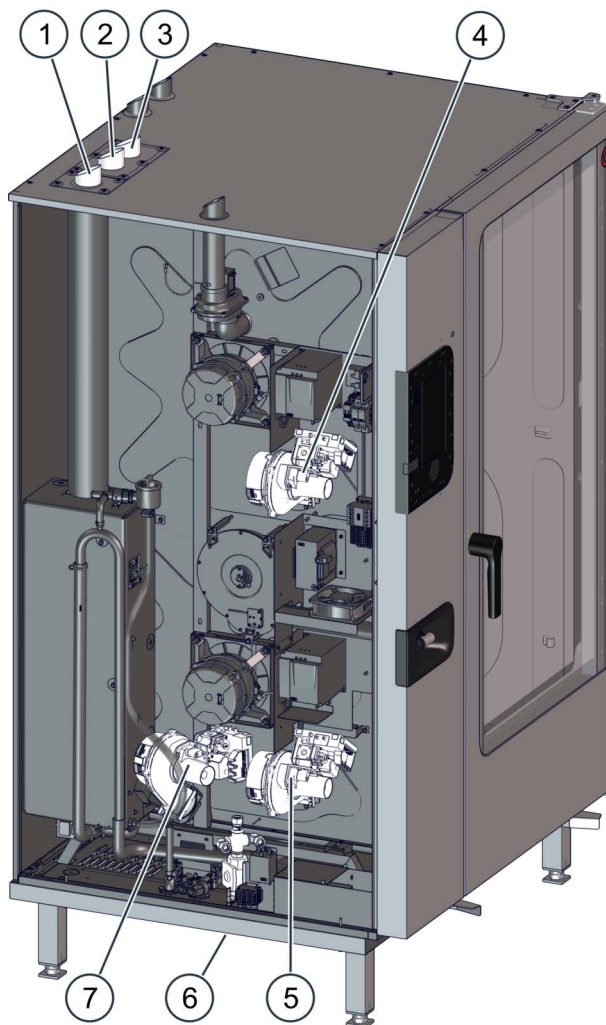

No.	Designation
1	Boiler burner exhaust outlet (found in boiler units only, i.e., units with a sprayer will not have this outlet)
2	Lower convection burner exhaust outlet
3	Upper convection burner exhaust outlet
4	Upper convection burner
5	Lower convection burner
6	Gas connection at the bottom of the unit
7	Boiler burner (found in boiler units only, i.e., units with a sprayer will not have this outlet)

6.2.3 Performing the Gas Installation

Prerequisites

Check whether the following prerequisite is met:

- A gas shut-off device has been installed on-site.

Required tools

- Leak detector spray / gas detector

Performing the Gas Installation

- | | | |
|-----|--|--|
| 1. | Check the type of gas, the gas pressure, and the gas connection rating against the specifications on the unit's nameplate.
Do not place the unit into operation or connect it to the gas supply point unless all specifications match. | 'Gas operation specifications' in 'Technical Data' on page 62 |
| 2. | Connect the gas connection. | |
| 3. | Make sure that none of the connection points outside the unit are leaking. | |
| 4. | Find out where the burners and their components are located and familiarize yourself with the burners' configuration. | 'Forced Air Burner and Gas Distribution Unit Locations' on page 45 |
| 5. | Turn on the unit. | |
| 6. | Make sure that none of the connection points outside or inside the unit are leaking. If required, fix any leaking connection points. | |
| 7. | Start a cooking profile with the 'Hot air' operation mode. | |
| 8. | Measure the supply flow pressure at the gas valve.
Result: <ul style="list-style-type: none"> ▪ If the supply flow pressure exceeds the specified upper limit, it can be reduced if necessary. ▪ If the supply flow pressure falls below the specified lower limit, you, as the installer, will not be able to correct the problem. ▪ If the reading falls within the specified limits, continue to step 9. ▪ If you cannot get the supply flow pressure to fall within the specified limits, use the gas shut-off device to shut off the gas supply to the combi oven and stop installing the system. | 'Measuring the Supply Flow Pressure' on page 47 |
| 9. | Measure the burner's CO emissions.
Do not place the unit into operation unless the emissions fall within the specified limits. | 'Measuring the Exhaust Gas Values' on page 47 |
| 10. | Turn off the unit. | |
| 11. | Notify the following parties (if required) of the fact that you have installed the gas unit and the corresponding system components: <ul style="list-style-type: none"> ▪ Gas provider ▪ The appropriate authorities as required by local regulations | |

6.2.4 Measuring the Supply Flow Pressure

Prerequisites

- A gas shut-off device has been installed on-site.
- The gas system must have been installed as indicated in the 'Performing the Gas Installation' on page 46 all the way to the 'Measure the supply flow pressure' step.

Required tools

- Pressure measuring instrument

Measuring the Supply Flow Pressure

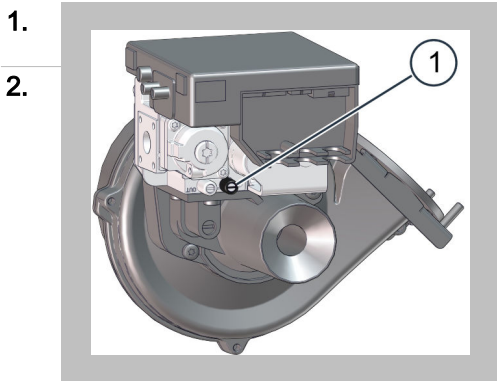

1. Measure the supply flow pressure at the gas valve (1) on the forced air burner.

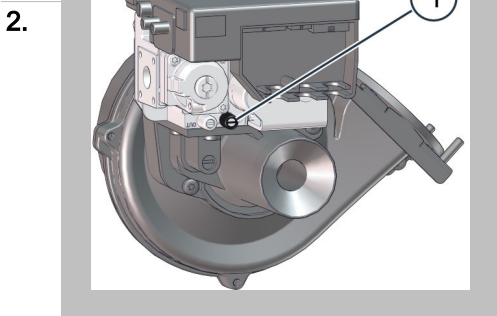

2. Compare the measured value with the specified limits – refer to 'Gas operation specifications' in 'Technical Data.' on page 62

Result:

- If the measured supply flow pressure is lower than the required values:
 - Notify your gas utility. Do not place the unit into operation. Shut off the gas to it.
- If the measured supply flow pressure is higher than the required values:
 - Restrict the supply flow pressure.

6.2.5 Measuring the Exhaust Gas Values

Required tools

- Exhaust gas analyzer

Measuring the Exhaust Gas Values

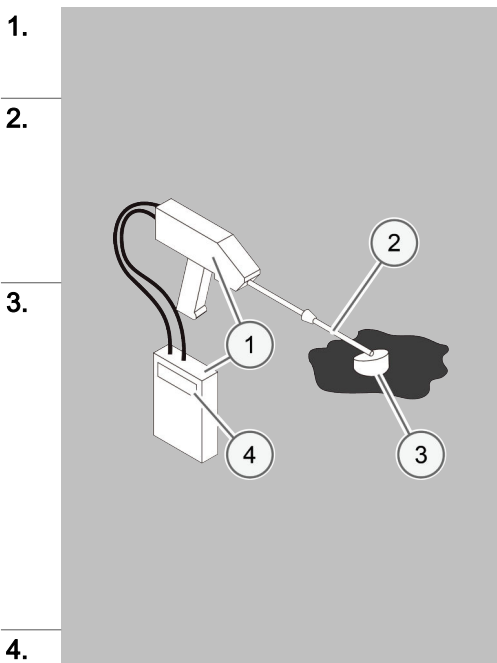

1. Thread the flue gas analyzer's (1) probe (2) into the exhaust outlet (3) for the burner for which you will be performing the measurement.

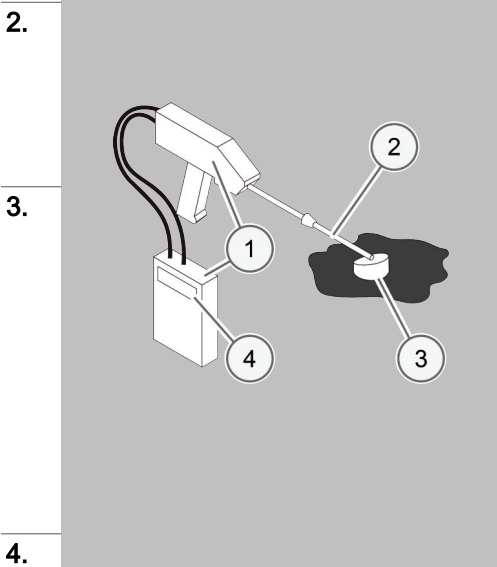

2. Measure the exhaust gas values.

Make sure to follow the operating instructions in the analyzer's manual.

Additional information:

If the analyzer shows approx. 21% O₂ or nothing, the probe is in the wrong exhaust outlet.

3. After one minute, check the analyzer's readings (4) and compare them with the specified limit – please refer to 'Gas operation specifications' in 'Technical Data.' on page 62

- If the limit is being exceeded, the unit needs to be checked as indicated in the adjustment instructions in the servicing documentation.
- If the O₂ value is below 3% or the CO value is above 500 ppm, the unit must be checked as indicated in the adjustment instructions in the servicing documentation.

Otherwise:

- Continue to step 4.

4. Document the measured values.

6.3 Network Connection

6.3.1 Planning the Network Connection

Meaning

It is crucial for the unit's network connection to be carefully and correctly installed in order for the unit to run safely and without any problems and to have the connection to the Internet required for this purpose.

Contact your service partner for more information.

Equipment provided by the customer and network connection rules

The following table shows the equipment that must be provided by the customer and the rules that have to be followed when making the relevant electrical connections.

Equipment	Rules
RJ45 port	A network jack for the combi oven must be installed close to the unit. If connecting multiple combi ovens, a separate network jack must be installed for each unit. Alternatively, the units can be networked together by installing a router.

6.3.2 Making the Network Connection

Installation steps

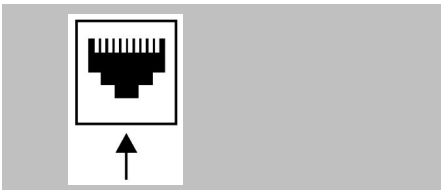

To establish an Internet connection, follow the steps below:

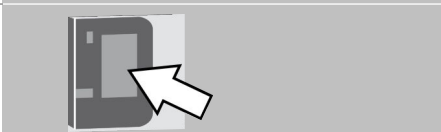
- 

Use a network cable to connect the combi oven's network port to the network jack preinstalled and intended for this use by the customer.
- 

When placing the combi oven into operation, check whether the 'KitchenConnect®' Internet icon indicates an active connection on the user interface.

Checking the network connection

Display in easyTouch	Button	Meaning
	'KitchenConnect®' gray	Internet is not active, installation unsuccessful, not connected
	'KitchenConnect®' white	Internet is active, installation successful, connected

6.4 Water connections

6.4.1 Water supply

Water connection standards and regulations

Make sure to comply with all national and state laws and regulations that apply to the water connection, as well as with all applicable local requirements and regulations set forth by the relevant local water utilities and authorities. These include, but are not limited to:

- Latest edition of the International Plumbing Code published by the International Code Council (ICC) or the Uniform Plumbing Code published by the International Association of Plumbing and Mechanical Officials (IAPMO)
- The Food Service Sanitation Manual published by the Food and Drug Administration (FDA)
- The standards published by the National Sanitation Foundation (NSF)

The unit must be installed with an appropriate backflow preventer in order to comply with all applicable federal, state, and local laws and regulations.

Water connection configuration

The unit is designed for a permanent hookup to the water supply that uses a connecting hose with a minimum diameter of 1/2"

The following parts in the scope of supply are required for a proper water connection.

- 2 x 3/4" GHT-M garden hose adapter (pre-assembled)
- Alternative 2 hoses of 1/2" inner diameter with one side 3/4" GHT-F to 3/4" BST

The adapters must be removed from the water connections on the unit side and stored in a safe place if the supply lines are long enough. If the length of the supplied hoses is not sufficient, use the adapters to make up water connection hoses of the required length.

Water quality and water hardness

- Ask your local water company for information regarding the quality and hardness of the water you get or check the water quality as explained in 'Checking the Water Quality' on page 51.
- For information on the required properties for the drinking water used with the unit, please refer to 'Technical Data' on page 62 section.
- If required, use suitable water treatment solutions. These can include, for instance, installing a water filter and/or a full water treatment system.
- Follow the steps in the 'Checking the Water Quality' on page 51 section in order to ensure that the required water quality values are met once the water goes through your water treatment system.
- Please note that for units with a boiler, the specified target values are for hardness (ppm CaCO₃). Other minerals dissolved in water may produce deposits as well. The need for removing these deposits will increase depending on the type of minerals in the water and as a function of the length of time that the unit has been running. These deposits can be removed with a chemical cleaning agent such as a descaler or by installing an upstream water treatment system (partial demineralization). The measures taken must be discussed with Technical Service on a case-by-case basis.

Connection diagram with water treatment system

Connection diagram

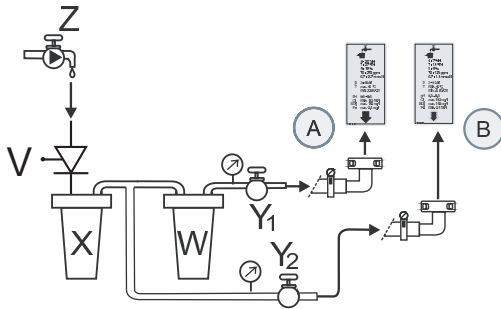

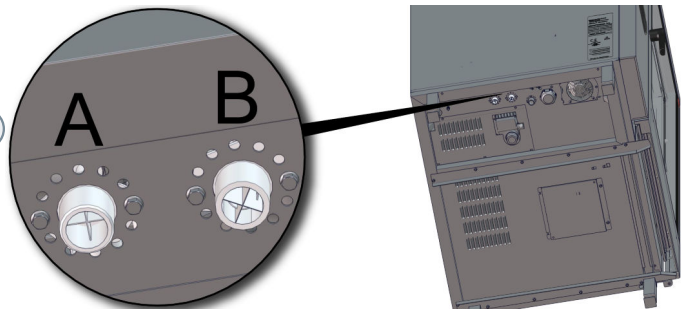

Unit connections



No.	Designation	Explanation
A	Water connection for boiler or water injection	For water quality information, refer to the 'Technical Data' on page 62 section
B	Water connection for cleaning and recoil hand shower	For water quality information, refer to the 'Technical Data' on page 62 section
Z	Water line provided by the customer	Water quality: Drinking water
X	0.003" sediment filter	A 0.003" sediment filter needs to be installed if the water has a lot of impurities.
W	Water treatment system for softening the water until it reaches the required soft water quality (can be omitted if the soft water quality is already adequate)	Recommendation: Partial demineralization cartridge
Y ₁ /Y ₂	Shut-off devices	Water valves
V	Suitable backflow preventer (required only for systems with sprayer if required by NSF; otherwise optional)	The unit may be installed with an appropriate backflow preventer in order to comply with all applicable federal, state, and local laws and regulations.

Installing the water supply connection

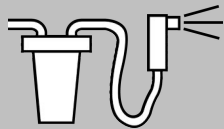
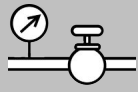
1.		Flush the water connection on the on-site water line (Z).
2.		Install the sediment filter (X) and, if necessary, a water treatment system (W).
3.		Install a separate shut-off device for each unit (Y or Y ₁ /Y ₂).
4.		Only in the UK: Install the check valve (DCV) in the water supply line.
5.		Connect the unit as shown in the connection diagram.

6.		Flush the sediment filter by using the recoil hand shower.
7.		Once you are done installing the water connection, close the shut-off device.
8.		Inform the user of the maintenance intervals for the filters and for the water treatment system (if any).

6.4.2 Checking the water quality

Required tools

You will need the following tools:

- 1 sample jar for getting a sample
- 1 conductivity meter
- A general hardness and carbonate hardness analysis kit, including two beakers (Part No. [3019010](#))
- Protective gloves

Checking the water quality

Measure the water's conductivity and total hardness. To do so, follow the instructions for the meter and the analysis kit.

Compare the measured values with the required values in the 'Technical Data' on page 62 section.

6.4.3 Drain Connection

Drain connection standards and regulations

Make sure to comply with all national and state laws and regulations, as well as with all applicable local requirements and regulations set forth by the relevant local utilities and authorities, that apply to the drain connection and to the wastewater's properties. These include, but are not limited to:

- Latest edition of the International Plumbing Code published by the International Code Council (ICC) or the Uniform Plumbing Code published by the International Association of Plumbing and Mechanical Officials (IAPMO)
- The Food Service Sanitation Manual published by the Food and Drug Administration (FDA)
- The standards published by the National Sanitation Foundation (NSF)

▲ Rules for safely installing the drain connection

In order to prevent hazards related to an improperly installed drain connection, make sure to observe the following rules:

- The drain pipes' material must be able to withstand a temperature of 140 °F.
- The drain pipe must not taper or have any other diameter-reducing deformations at any point.
- The drain pipe's minimum diameter will depend on the pipe's total length and the number of elbows used. For a pipe length of up to 6 feet and a maximum of two elbows, the minimum inner diameter will be 2". For a pipe length of 6 to 12 feet or a maximum of three elbows, the minimum inner diameter will be 2½".
- The drain pipe must have a downward slope of min. 3.5% (2°).
- Do not directly connect the unit drain to the sewer system vertically.
- The connection between the drain pipe and the sewer system must be located outside the perimeter of the unit's base area. Due to potential wastewater vapors, there must not be a drain connection or open sewer line below the unit's base area.
- The drain connection must be implemented using a rigid, naturally ventilated pipe.
- A ventilation clearance of at least 1" must be maintained between the end of the drain pipe and the upper edge of the drain or pan.
- Do not connect any other units to the combi oven's drain pipe.
- Do not connect the combi oven to any other units' drain pipe.

Connection diagram

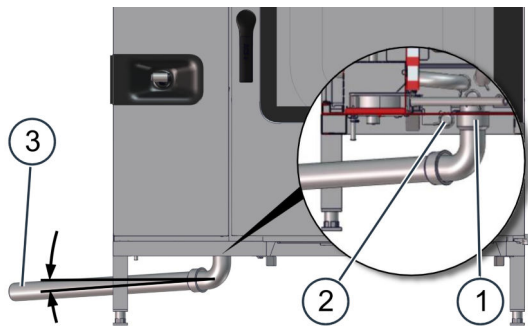

No.	Designation	Function
1	Appliance drain	At the bottom of the unit, connection point C – please refer to 'Connection drawing' on page 68
2	Safety overflow	<ul style="list-style-type: none"> ▪ At the bottom of the unit, connection point M – please refer to 'Connection drawing' on page 68 ▪ Used to drain water in the event of a failure (blockage)
3	Drain pipe	<ul style="list-style-type: none"> ▪ Minimum inner diameter = 2" ▪ Downward slope: min. 3.5% (2°) Drain options: <ul style="list-style-type: none"> ▪ Open pan ▪ Channel

Installing the drain connection

Connect the unit as shown in the connection diagram.

6.5 Installing the fully automatic oven cleaning system

6.5.1 Components of Fully Automatic Oven Cleaning System

Cleaning agents and rinse aid

Only use the products specified here in order to clean the combi oven.

NOTICE! The warranty will be void if there is any damage that can be traced back to the use of incorrect cleaning agents.

The following table lists the cleaning agents and rinse aids that can be used:

Designation	Product	Label color
Cleaning agents	ConvoClean forte / new	Red
Rinse aid	ConvoCare	Green

Components and Configuration of Fully Automatic Oven Cleaning System with Connected Canisters

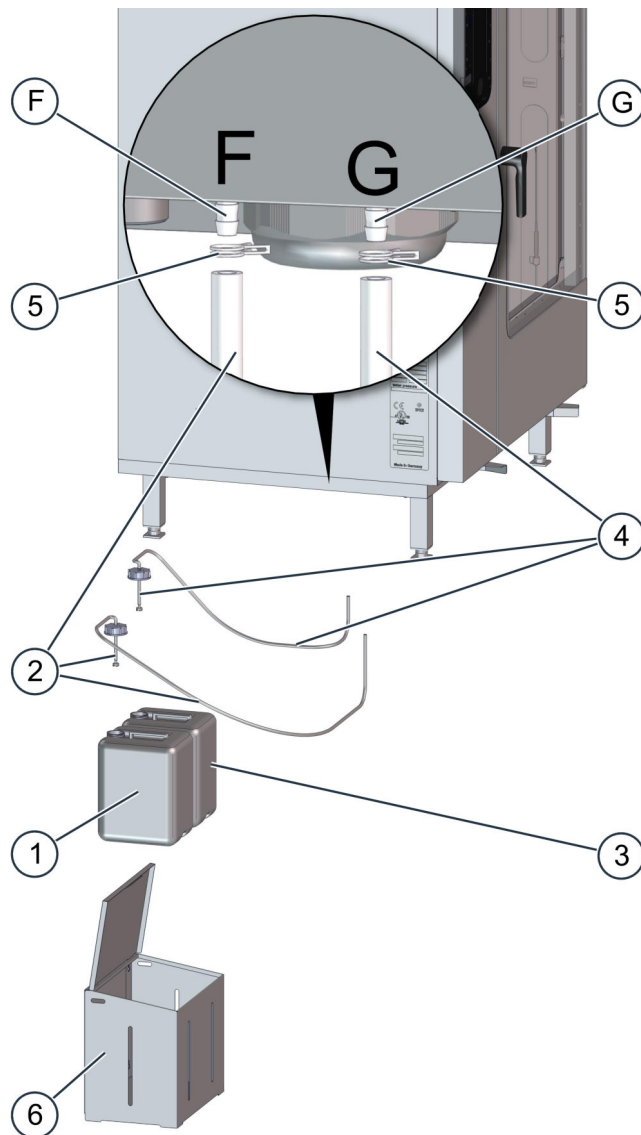

No.	Designation	Color coding
F	Unit connection for rinse aid	Green (inscription)
G	Unit connection for cleaning agent	Red (inscription)
1	Canister with ConvoCare rinse aid (ready-to-use solution with a defined mix ratio)	Green (label)
2	Suction tube with suction nozzle for rinse aid	Green (tube)
3	Canister with ConvoClean new or ConvoClean forte cleaning agent	Red (label)
4	Suction tube with suction nozzle for cleaning agent	Red (tube)
5	D10 wire hose clamp	-
6	Box for cleaning agent canister (optional accessory)	-

Box for cleaning agent canister (optional accessory)

The box for the cleaning agent canister (6) is an optional combi oven accessory that is available from the manufacturer.

The box can be screwed onto a wall using the holes in the back panel. In order to make it easier to clean the kitchen floor, you can fasten the box at a certain distance from the floor. When doing so, make sure to observe the requirements described in 'Installation location for cleaning agent and rinse aid canisters.'

Installation location for cleaning agent and rinse aid canisters

Set up the canisters as follows:

- The canisters should be easily accessible on a flat, level surface next to the device.
- The canister's supporting surface must not be higher than the edge where the feet and the unit case meet.
- The canister's supporting surface must not be more than 3 feet below this edge.

6.5.2 Connecting the Fully Automatic Cleaning System

Connecting the fully automatic oven cleaning system with canisters

1.

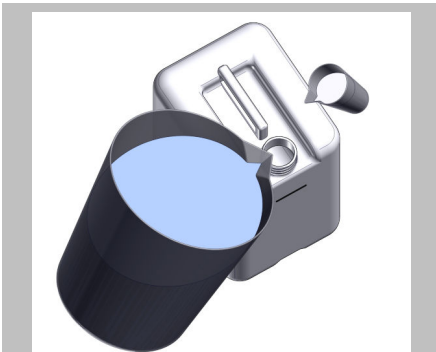

Mix the included ConvoCare Concentrate with soft water in the empty canister for ConvoCare rinse aid. Make sure to follow the operating manual instructions on mixing ConvoCare rinse aid in canisters.

2.

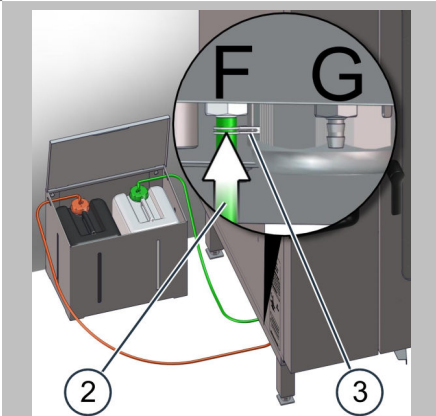

Slip the green suction tube (2) for ConvoCare rinse aid onto the barbed nipple on the rear bulkhead fitting (F) and secure the tube using the wire hose clamp (3) (see 'Rinse-aid connection' adhesive label on the left unit side).

3.

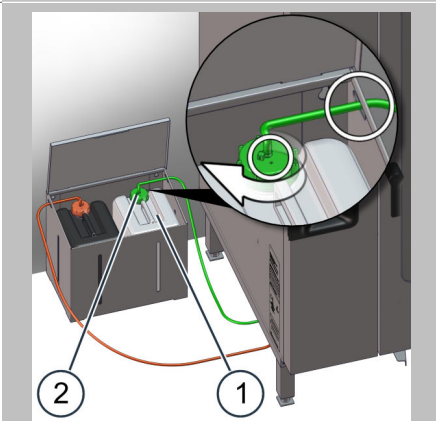

Insert the suction nozzle on the green suction tube (2) into the rinse aid canister (1). The tube must be routed without any kinks and the canister's vent opening must be open and clear.

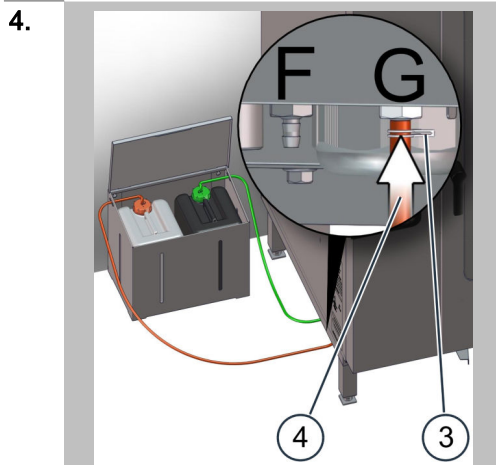

Slip the red suction tube (4) for ConvoClean forte cleaning agent onto the barbed nipple on the front bulkhead fitting (G) and secure the tube using the wire hose clamp (3) (see 'Cleaning-agent connection' adhesive label on the left unit side).

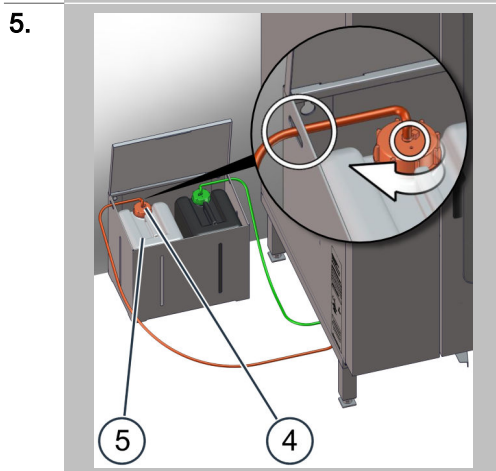

Insert the suction nozzle on the red suction tube (4) into the cleaning agent canister (5). The tube must be routed without any kinks and the canister's vent opening must be open and clear.

6.6 Installing the Grease Collection Canister

6.6.1 Connecting the Grease Collection Canister

Required accessories

ConvoGrill includes the following original accessories, which you will need in order to connect the automatic grease management system. Make sure to use these original accessories exclusively:

- Connection tube with attached rotating canister screw closure
- Empty canister suitable for pumped out grease
- Hose clamp for securing the tube connection on the combi oven
- Forked holder for holding the canister screw closure with the connection tube while emptying and cleaning the grease collection canister

Connecting the grease collection canister (ConvoGrill)

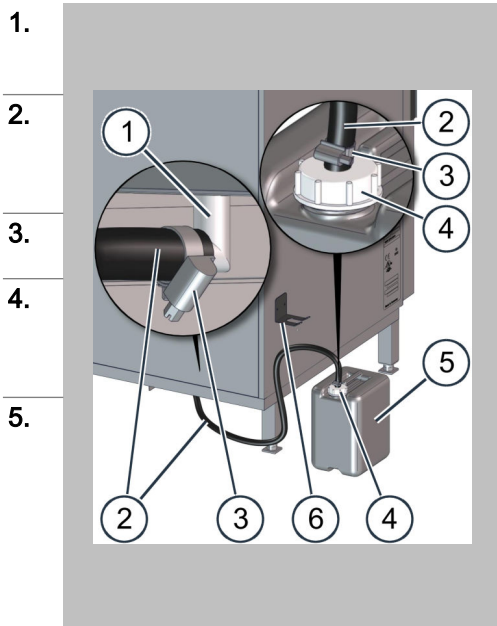

1. Check the accessories for damage. Continue with the installation only if the parts are undamaged and have no leaks.

2. Slip the open end of the automatic grease management system's connection tube (2) onto the drain (1) at the back of the combi oven's bottom. Then secure the tube (2) using the hose clamp (3).

3. Screw the canister screw closure (4) on the connection tube (2) onto the grease collection canister (5).

4. Place the grease collecting canister (5) in a suitable location and make sure the connecting hose (2) has a consistent slope and no kinks. It may be necessary to route or fasten the hose.

5. Secure the forked holder (6), which is meant for holding the canister screw closure (4) with the connection tube, at an accessible point close to the drain (1). To do this, use the double-sided adhesive tape on the back of the holder or the pre-drilled holes on the holder.

On units with a disappearing door:

Do NOT place the holder (6) on the combi oven case side along which the unit door is slid back.

Grease collection canister installation location

Set up the grease collection canister as follows:

- The canister must be in an upright position and easily accessible on a flat, level surface next to the unit.
- The canister's supporting surface must not be more than 6" above the contact point between the unit and its base.
- The operator's working area must be kept clear.

7 Placing into operation

7.1 Working Safely When Putting the Unit Into Operation

For your safety when working with/on the combi oven

Before placing the combi oven into operation, read and understand the rules, risks, and hazards specified in the 'For Your Safety' section and follow all the corresponding instructions without exception. Follow the relevant instructions in the operating manual when testing cooking and cleaning sequences.

What to do if you smell gas

If you smell gas, follow the steps below without exception:

- Immediately shut off the gas.
- Thoroughly ventilate the room.
- Do not operate any electrical devices or equipment. Make sure not to cause any sparks.
- Evacuate the building.
- Call the gas utility and, if necessary, the fire department on a telephone found outside the hazardous area.

Basic rules for safe operation

If the combi oven is moved in an impermissible manner after installation (on purpose or by accident), do not continue to operate the unit unless all the following requirements are met:

- The unit and the accessories being used do not have any obvious damage.
- The supply lines installed for electrical power, water, wastewater, and cleaning agents do not have any obvious damage, have a secure fit, are not dripping anywhere, and appear to be safe and fully functional after a visual inspection.
- The 'Requirements concerning the combi oven's functional capability on page 16' are being met.
- The 'Requirements concerning the combi oven's surroundings' are being met.
- All warning labels are at their intended location.

Gas units only:

- A service technician has checked all the components in the combi oven that convey gas in order to make sure that there are no leaks at any of their connection points. Moreover, the technician has checked to make sure that none of the specified points outside and inside the unit have any leaks.

Rules for safely running the unit

In order to avoid hazards, follow the rules below when running the unit:

- Make sure to only use your hands when using the unit's controls (buttons, switches, touchscreens).
- Do not cover, obstruct, or block the exhaust vents, exhaust outlets, or ventilation ports at the top of the unit or the ventilation openings at the bottom.
- Bakeware must be slid in properly as indicated in the rules in the operating manual's 'Placing Bakeware Inside the Unit' section.
- The suction panel needs to be properly locked in place.

7.2 Procedure for Placing the Unit into Operation

Checks before placing the unit into operation

Before putting the combi oven into operation, check whether the prerequisites below are being met:

- The unit and the accessories being used do not have any obvious damage.
- The unit has been set up in such a way that it will not shift or topple over; the requirements concerning the location and the unit's surroundings are met (please refer to the 'Setup' on page 29).
- Protective films, cardboard, securing devices for shipping, etc., have been removed completely.
- There is nothing being stored inside the oven cavity and there is nothing inside the oven cavity other than required cooking accessories (food containers, for example).
- The unit has been installed as per the specifications in the 'Installation' on page 37 section.
- The supply lines installed for electrical power, water, wastewater, and cleaning agents do not have any obvious damage, have a secure fit, are not dripping anywhere, and appear to be safe and fully functional after a visual inspection.
- The unit has been subjected to an individual electric inspection (see below).
- All safety guards and devices are in their intended place and are working properly.
- All warning labels are at their intended location.
- The unit and the accessories being used must have been cleaned properly.

Do not place the unit into operation unless all specified prerequisites are met.



Individual electric inspection

An individual electric inspection includes the following three steps:



- Inspection: Visual inspection for damage and improper use
- Measurement: Measurements performed as per generally accepted standards and practices (equipment grounding conductor resistance, insulation resistance, equipment grounding conductor current / leakage current)
- Testing: Functional test

The individual electric inspection must be repeated at regular intervals as required by law.

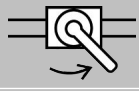
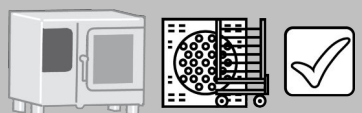
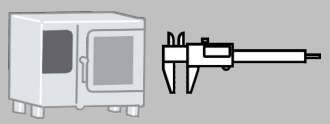





Preparing to place the unit into operation

1.		Bring the ambient temperature to the permissible operating temperature.
2.		Turn on the circuit breaker.
3.		Open the water supply.
4.		Open the gas flow (in the case of gas units).
5.		<p>Check to make sure that the following are installed properly in the right position:</p> <ul style="list-style-type: none"> ▪ Suction panel ▪ Loading trolley
6.		<p>Measure the door gap at the front of the unit as indicated in 'Measuring Unit Gaps' on page 60:</p> <p>If the measured gap falls outside the corresponding tolerance range, or if the unit door's upper edge is not aligned with the unit case's upper edge, the unit door will need to be adjusted.</p> <p>Adjust the door as indicated in the service documentation or contact the manufacturer.</p>

7 Placing into operation

7.		Turn the combi oven on.
8.		Set the following: <ul style="list-style-type: none">▪ Date▪ Time▪ Language

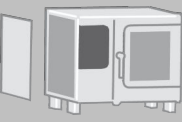
Placing the unit into operation

1.		Start the cooking sequence using the following cooking data: <ul style="list-style-type: none">▪ 'Combi-steam' operating mode▪ 300 °F▪ 10 minutes
2.		Check the following: <ul style="list-style-type: none">▪ Is the oven light on?▪ Is the fan wheel running?▪ Are there any leaks in the wastewater and supply water systems?▪ Is the temperature increasing inside the oven cavity?
3.		Start the cooking sequence using the following cooking data: <ul style="list-style-type: none">▪ 'Steam' operating mode▪ 210 °F▪ 10 minutes
4.		Check whether steam is being produced inside the oven cavity (carefully open the unit door).
5.		Only for water injection units: Use the pressure regulator to adjust the pressure gauge in the steam generation system's water supply: <ul style="list-style-type: none">▪ [psi] 21.76▪ [bar] 1.5
6.		Start the fully automatic cleaning process with the cleaning profile for light soiling.
7.		Check that the cleaning sequence is completed without any error messages.

Briefing the user

Brief the user on all safety-relevant functions, mechanisms, and devices. Show the user how to operate the unit and fill out the checklist enclosed with the unit.

Warranty information

Warranty claims involving your combi oven will only be honored if the unit has been installed by a qualified service technician from an authorized service company as per the instructions in this installation manual. Please note that warranty claims will only be honored if the manufacturer has a copy of the fully completed checklist.

Follow the link below or scan the QR code to access the checklist:
'Checklist'



The warranty will be void if there is any damage that can be traced back to improper setup, installation, use, cleaning, use of cleaning agents, maintenance, repair, or descaling.

Further information on the warranty conditions can be found on the Internet at www.convotherm.com

7.3 Measuring unit gaps

Measuring unit gaps

The unit gaps' measured widths must fall within the following tolerance ranges:

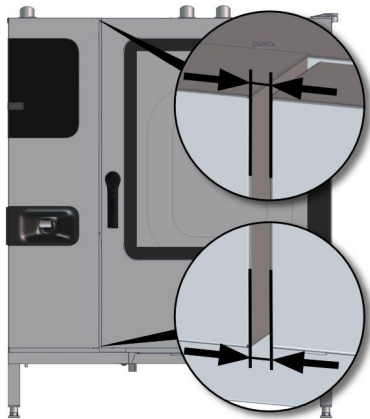

Designation	Measuring condition	Tolerance range
Door gap at the front of the unit	The unit door must be closed.	$2/5" \pm 1/25"$ (0.4" \pm 0.04")

If the door gap falls outside the tolerance range, please contact Customer Service.

8 Removing from Service and Disposal

8.1 Removing from Service and Disposal

▲ Rules for working safely and responsibly when removing the unit from service

Avoid endangering yourself and others by following the rules below:

- Always keep the kitchen floor dry in order to reduce the risk of accidents occurring.
- Before disposing of the unit, close the combi oven door and remove the door handle.
- Cleaning agents must be disposed of as instructed in the canisters in order to avoid damaging the environment.

Prerequisites

Check the following before removing the unit from service:

- The unit has been de-energized.
- The gas has been shut off.
- The water supply has been shut off.

Removing from service

To remove your unit from service, undo all setup and installation work step-by-step in opposite order (please refer to the 'Installation' on page 37, 'Transportation' on page 27, and 'Setup' on page 29 sections).

Do not move the unit before disconnecting all of its connections.

The following work must be done properly in order to remove the unit from service:

- Removing the unit's water connection
- Removing the unit's drain connection
- Removing or disconnecting the electrical connections
- Removing the unit's gas connection
- Removing the exhaust extraction system
- Removing the door lock
- Removing the cleaning agent and rinse aid connections
- Properly disposing of all cleaning agents as indicated in the corresponding EC safety data sheets and the cleaning agent containers
- Removing the grease collection canister
- Disposing of pumped-out used grease in compliance with the relevant country-specific laws and regulations, as well as in compliance with all applicable rules and regulations set forth by the relevant local disposal companies and authorities

Disposal

Contact the manufacturer in order to arrange for your unit to be disposed of in an environmentally responsible manner. The manufacturer has an ISO 14001:2004-certified environmental management system and will dispose of your old unit in compliance with all applicable environmental protection regulations.

9 Technical data

9.1 Dimensions and weights

C4 EB/ES dimensions

		20.10	20.20
Unit with packaging			
Width	[in]	46.7	56.3
Height	[in]	85.0	85.0
Depth	[in]	39.0	46.9
Unit without packaging			
Width of units featuring a right-hinged door	[in]	35.04	44.69
Width of units with a disappearing door, incl. guide bracket	[in]	36.89	46.54
Height	[in]	76.46	76.46
Depth when the unit door is closed	[in]	32.28	40.16
Safety clearances			
Rear	[in]	2	2
Right-hand side (units featuring a right-hinged door)	[in]	2	2
Right-hand side (units featuring a disappearing door)	[in]	2	2
Left-hand side (larger gap recommended for servicing)	[in]	2	2
Above (for ventilation)	[in]	20	20

C4 GB/GS dimensions

		20.10	20.20
Unit with packaging			
Width	[in]	46.7	56.3
Height	[in]	85.0	85.0
Depth	[in]	39.0	46.9
Unit without packaging			
Width of units featuring a right-hinged door	[in]	35.04	44.69
Width of units with a disappearing door, incl. guide bracket	[in]	39.45	49.10
Height	[in]	76.46	76.46
Depth when the unit door is closed	[in]	32.28	40.16
Safety clearances			
Rear	[in]	2	2
Right-hand side (units featuring a right-hinged door)	[in]	2	2
Right-hand side (units featuring a disappearing door)	[in]	2	2
Left-hand side (larger gap recommended for servicing)	[in]	2	2
Above (for ventilation)	[in]	39	39

C4 EB weights

		20.10	20.20
Weight without packaging			
- Right-hinged door	[lbs]	608	794
- Disappearing door	[lbs]	653	838

		20.10	20.20
Packaging weight			
Packaging weight	[lbs]	88	106

C4 ES weights

		20.10	20.20
Weight without packaging			
- Right-hinged door	[lbs]	575	754
- Disappearing door	[lbs]	619	798
Packaging weight			
Packaging weight	[lbs]	88	106

C4 GB weights

		20.10	20.20
Weight without packaging			
- Right-hinged door	[lbs]	644	840
- Disappearing door	[lbs]	688	884
Packaging weight			
Packaging weight	[lbs]	88	106

C4 GS weights

		20.10	20.20
Weight without packaging			
- Right-hinged door	[lbs]	606	800
- Disappearing door	[lbs]	650	829
Packaging weight			
Packaging weight	[lbs]	88	106

9.2 Maximum permissible loading weight

C4 EB/ES/GB/GS

The total weight placed on the rack levels must not exceed the combi oven's maximum permissible loading weight:

		20.10	20.20
Maximum load weight			
Per combi oven	[lbs]	220	397
Per shelf	[lbs]	33	33

9.3 EB/ES Electrical Supply

C4 EB/ES

		20.10	20.20
3~ 208/240V 60Hz (3/PE)			
Rated power consumption	[kW]	31.3 / 41.6	54.4 / 72.3
Hot air output	[kW]	30.9 / 41.2	54.1 / 71.9
Steam power (EB only)	[kW]	22.1 / 29.4	32.7 / 43.5
Rated current	[A]	87.1 / 100.1	151.1 / 174.1
Recommended supply connection			
Field wire gauge	AWG	2	2/0 3/0
Ground wire gauge	AWG	6	4
Conductor insulation rating		194 °F	194 °F
3~ 440/480V 60 Hz			
Rated power consumption	[kW]	32.6 / 38.6	56.3 / 66.8
Hot air output	[kW]	31.8 / 37.8	55.4 / 66.0
Steam power (EB only)	[kW]	22.7 / 27.0	33.5 / 39.9
Rated current	[A]	42.8 / 46.5	73.9 / 80.5
Recommended supply connection			
Field wire gauge	AWG	6	4/3
Ground wire gauge	AWG	8	6
Conductor insulation rating		194 °F	194 °F
3~ 208 V 60 Hz (3/PE)			
Rated power consumption	[kW]	31.3	54.4
Hot air output	[kW]	30.9	54.1
Steam power (EB only)	[kW]	22.1	32.7
Rated current	[A]	87.1	151.1
Recommended supply connection			
Field wire gauge	AWG	2	2/0
Ground wire gauge	AWG	6	4
3~ 240 V 60 Hz (3/PE)			
Rated power consumption	[kW]	41.6	72.3
Hot air output	[kW]	41.2	71.9
Steam power (EB only)	[kW]	29.4	43.4
Rated current	[A]	100.1	174.1
Recommended supply connection			
Field wire gauge	AWG	2	3/0
Ground wire gauge	AWG	6	4

9.4 GB/GS Electrical Supply

C4 GB

		20.10	20.20
1N~ 120V 60 Hz			
Rated current	[A]	8.3	10.6
Recommended supply connection			
Field wire gauge	AWG	14	14
Ground wire gauge	AWG	14	14
Conductor insulation rating		194 °F	194 °F

9.5 Gas Characteristic Values for Natural Gas (USA), Propane (USA)

C4 GB/GS

Gas type		Natural Gas (USA)	Propane (USA)
Operating materials			
Natural gas, propane		x	x
Gas supply parameters			
Gas line connection for unit sizes 20.10 and 20.20		3/4" NPT	3/4" NPT
Supply flow pressure	[inch WC]	7	11
Exhaust extraction system			
Air ventilation system with safety shutdown function		Mandatory	Mandatory
Exhaust gas parameters			
Exhaust gas reading CO ₂	[%]	9.4 - 11.1	10.5 - 12.5
Exhaust gas reading CO	[ppm]	< 500	< 500

9.6 Heat loss

C4 EB

		20.10	20.20
When the unit door is closed			
Latent	[BTU/h]	6500	10500
Sensible	[BTU/h]	8500	13400

C4 ES

		20.10	20.20
When the unit door is closed			
Latent	[BTU/h]	6500	11500
Sensible	[BTU/h]	8500	13400

C4 GB/GS

		20.10	20.20
When the unit door is closed			
Latent	[BTU/h]	6700	11600
Sensible	[BTU/h]	10500	14600

9.7 Water connection

C4 EB/ES/GB/GS

Water supply (cold only)		
Water supply		2 x 3/4" GHT-M garden hose adapter; Alternative, 2 hoses 1/2" inner diameter with one side 3/4" GHT-F to 3/4" BST. The unit is designed for a fixed connection to the water supply using a connecting hose with a minimum inner diameter of 1/2"
Flow pressure	[psi] / [bar]	22 - 87 psi / 1.5 - 6 bar
Pressure gauge in water supply	[psi] / [bar]	21.76 psi / 1.5 bar
Water drain		
Version		Naturally ventilated pipe to open pan or drain/channel
Type		2" inner diameter
Wastewater temperature	[°F] / [°C]	max. 140°F / 60°C
Slope for drain pipe		min. 3.5% (2°)
Safety overflow	[inch]	3.2" x 1"

9.8 Water quality

C4 EB/GB

Water connection (A) for boiler; water connection (B) for cleaning, recoil hand shower		
General water quality		Drinking water
Hardness	[ppm]	70 - 360 ppm (4 - 21 gpg)
TDS (total dissolved solids)	[ppm]	70 - 360
Total alkalinity	[ppm]	50 - 100
Water connections (A) and (B)		
Temperature	[°F]	max. 104
pH value		6.5 - 8.5
Cl ⁻ (chloride)	[ppm]	max. 60
Cl ₂ (free chlorine)	[ppm]	max. 0.2
SO ₄ ²⁻ (sulfate)	[ppm]	max. 150
Fe (iron)	[ppm]	max. 0.1
SiO ₂ (silicate)	[ppm]	max. 13
NH ₂ Cl (monochloramine)	[ppm]	max. 0.2

C4 ES/GS

Water connection (A) for water injection

General water quality		Drinking water
Hardness	[ppm]	70 - 125 ppm (4 - 7 gpg)
TDS (total dissolved solids)	[ppm]	70 - 125
Total alkalinity	[ppm]	50 - 100

Water connection (B) for cleaning, recoil hand shower

General water quality		Drinking water
Hardness	[ppm]	70 - 360 ppm (4 - 21 gpg)
TDS (total dissolved solids)	[ppm]	70 - 360
Total alkalinity	[ppm]	50 - 100

Water connections (A) and (B)

Temperature	[°F]	max. 104
pH value		6.5 - 8.5
Cl ⁻ (chloride)	[ppm]	max. 60
Cl ₂ (free chlorine)	[ppm]	max. 0.2
SO ₄ ²⁻ (sulfate)	[ppm]	max. 150
Fe (iron)	[ppm]	max. 0.1
SiO ₂ (silicate)	[ppm]	max. 13
NH ₂ Cl (monochloramine)	[ppm]	max. 0.2

9.9 Water consumption during cooking and cleaning

C4 EB/GB

		20.10	20.20
Hard and soft water			
Average water consumption with cleaning	[gph]	3.6	4.5

C4 ES/GS

		20.10	20.20
Hard and soft water			
Average water consumption with cleaning	[gph]	4.2	5.7

10 Connection drawings

10.1 Convotherm maxx pro 20.10 electrical unit

C4 20.10 dimensions and connection points (right-hinged unit door)

Front view

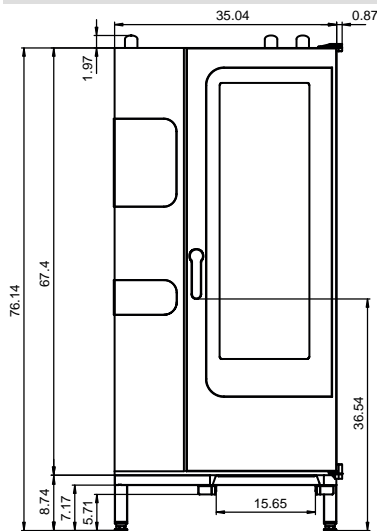

Connection points, unit floor

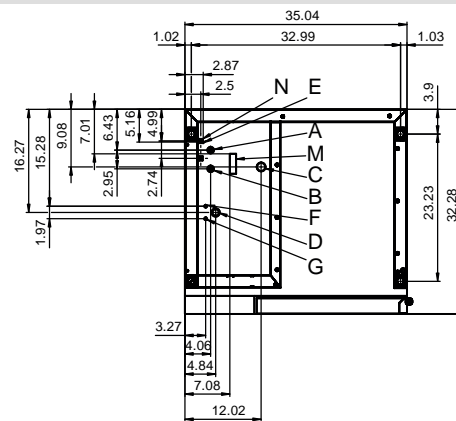

Drain connection detail

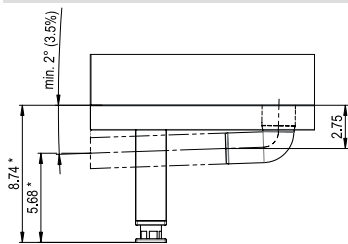

* The distance depends on how much the feet are extended (max. +0.984")

View from above with wall clearances

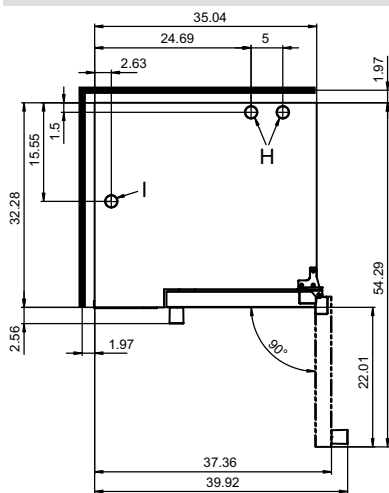

Key

- A Water connection (for boiler or water injection)
- B Water connection (for cleaning, recoil hand shower)
- C Drain connection (2" internal diameter)
- D Electrical connection
- E Bonding
- F Rinse-aid connection (optional)
- G Cleaning-agent connection (optional)
- H Air vent (2" internal diameter)
- I Dry air intake (2" internal diameter)
- M Safety overflow 3.2" x 1"
- N Ethernet connection RJ45 (optional)

C4 20.10 dimensions and connection points (disappearing door)

Front view

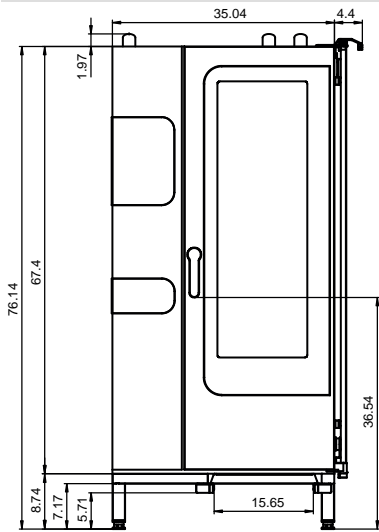

Connection points, unit floor

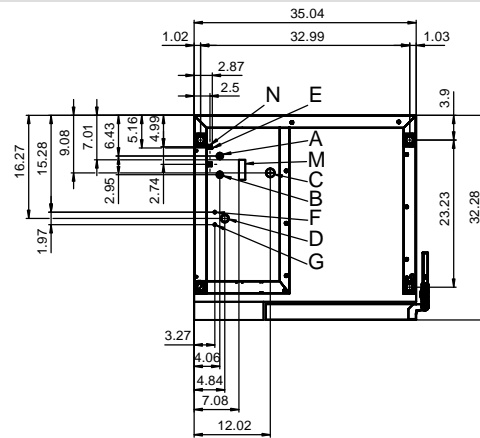

Drain connection detail

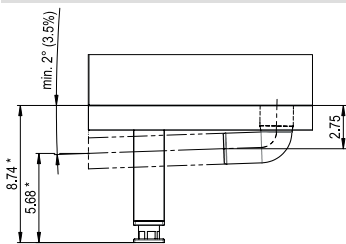

* The distance depends on how much the feet are extended (max. +0.984")

View from above with wall clearances

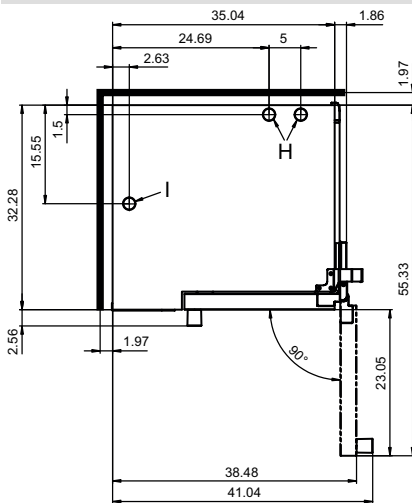

Key

- A Water connection (for boiler or water injection)
- B Water connection (for cleaning, recoil hand shower)
- C Drain connection (2" internal diameter)
- D Electrical connection
- E Bonding
- F Rinse-aid connection (optional)
- G Cleaning-agent connection (optional)
- H Air vent (2" internal diameter)
- I Dry air intake (2" internal diameter)
- M Safety overflow 3.2" x 1"
- N Ethernet connection RJ45 (optional)

10.2 Convotherm maxx pro 20.10 gas unit boiler

C4 20.10 dimensions and connection points (right-hinged unit door)

Front view

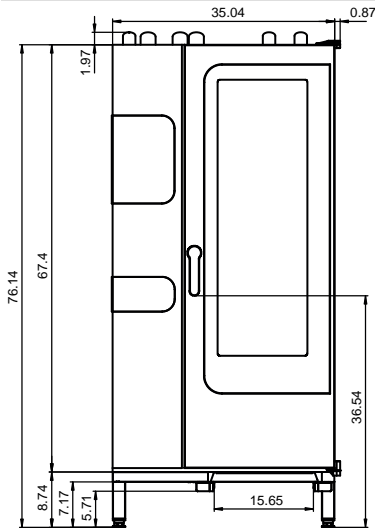

Connection points, unit floor

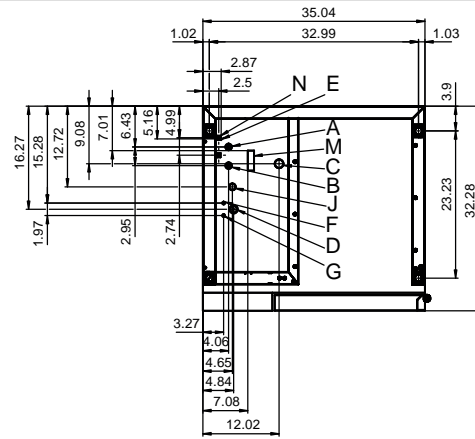

Drain connection detail

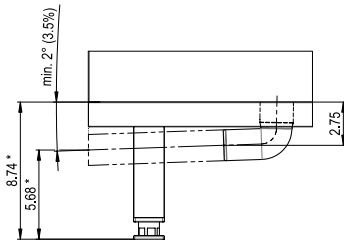

* The distance depends on how much the feet are extended (max. +0.984")

View from above with wall clearances

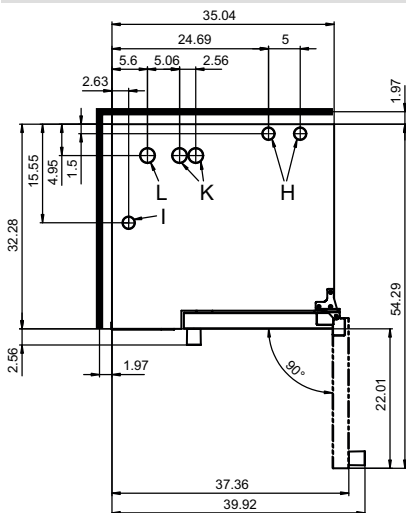

Key

- A Water connection (for boiler or water injection)
- B Water connection (for cleaning, recoil hand shower)
- C Drain connection (2" internal diameter)
- D Electrical connection
- E Bonding
- F Rinse-aid connection (optional)
- G Cleaning-agent connection (optional)
- H Air vent (2" internal diameter)
- I Dry air intake (2" internal diameter)
- J Gas connection
- K Convection burner exhaust outlet (2" internal diameter)
- L Boiler burner exhaust outlet (2.37" internal diameter)
- M Safety overflow 3.2" x 1"
- N Ethernet connection RJ45 (optional)

C4 20.10 dimensions and connection points (disappearing door)

Front view

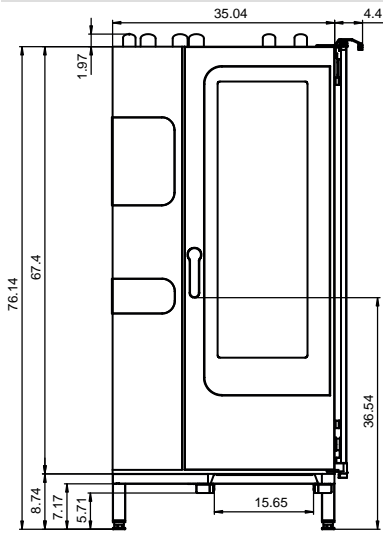

Connection points, unit floor

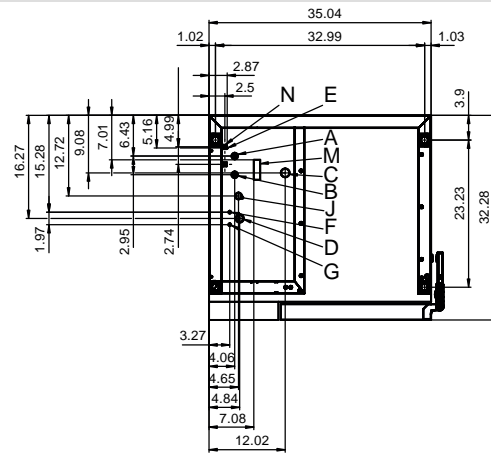

Drain connection detail

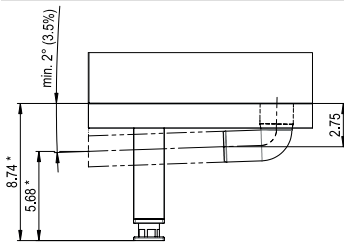

* The distance depends on how much the feet are extended (max. +0.984")

View from above with wall clearances

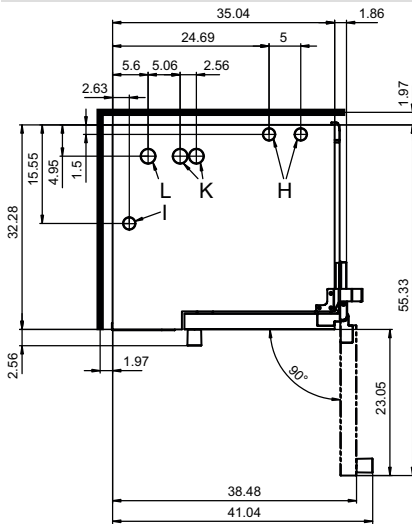

Key

- A Water connection (for boiler or water injection)
- B Water connection (for cleaning, recoil hand shower)
- C Drain connection (2" internal diameter)
- D Electrical connection
- E Bonding
- F Rinse-aid connection (optional)
- G Cleaning-agent connection (optional)
- H Air vent (2" internal diameter)
- I Dry air intake (2" internal diameter)
- J Gas connection
- K Convection burner exhaust outlet (2" internal diameter)
- L Boiler burner exhaust outlet (2.37" internal diameter)
- M Safety overflow 3.2" x 1"
- N Ethernet connection RJ45 (optional)

10.3 Convotherm maxx pro 20.10 gas unit water injection

C4 20.10 dimensions and connection points (right-hinged unit door)

Front view

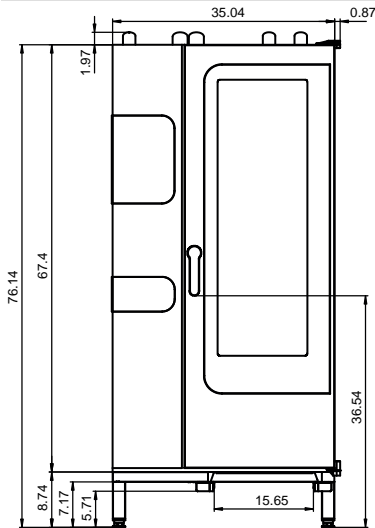

Connection points, unit floor

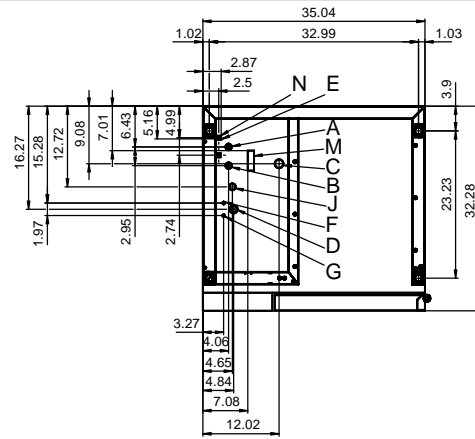

Drain connection detail

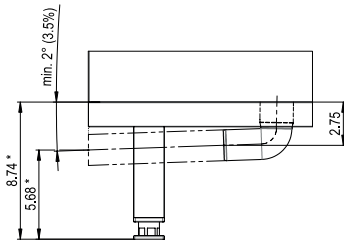

* The distance depends on how much the feet are extended (max. +0.984")

View from above with wall clearances

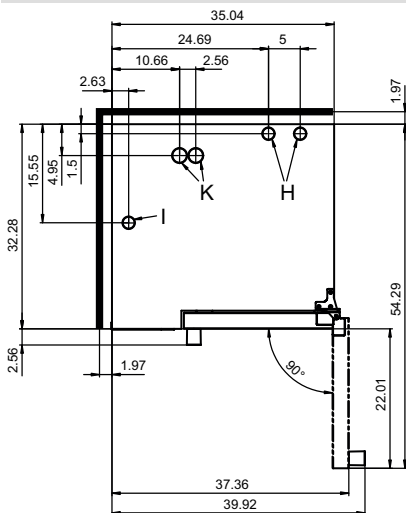

Key

- A Water connection (for boiler or water injection)
- B Water connection (for cleaning, recoil hand shower)
- C Drain connection (2" internal diameter)
- D Electrical connection
- E Bonding
- F Rinse-aid connection (optional)
- G Cleaning-agent connection (optional)
- H Air vent (2" internal diameter)
- I Dry air intake (2" internal diameter)
- J Gas connection
- K Exhaust outlet (2" internal diameter)
- M Safety overflow 3.2" x 1"
- N Ethernet connection RJ45 (optional)

C4 20.10 dimensions and connection points (disappearing door)

Front view

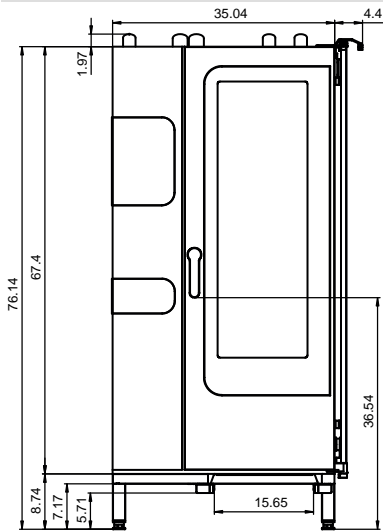

Connection points, unit floor

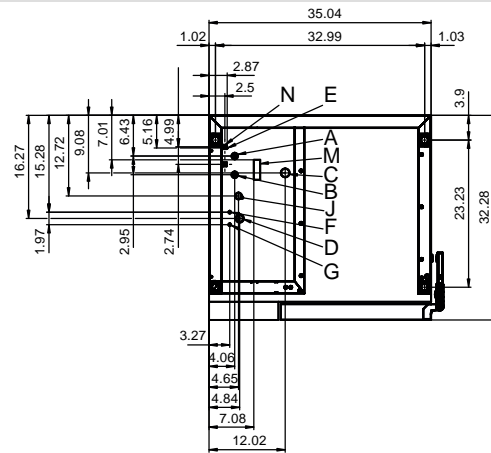

Drain connection detail

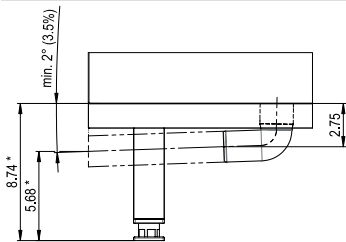

* The distance depends on how much the feet are extended (max. +0.984")

View from above with wall clearances

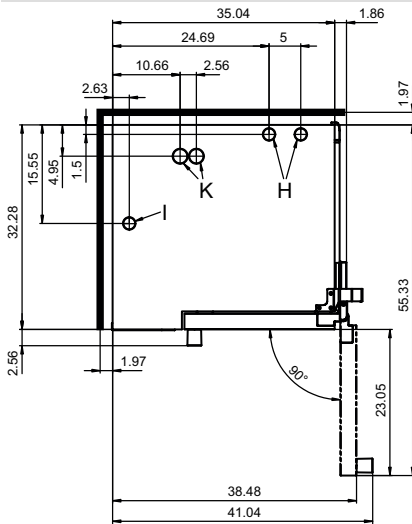

Key

- A Water connection (for boiler or water injection)
- B Water connection (for cleaning, recoil hand shower)
- C Drain connection (2" internal diameter)
- D Electrical connection
- E Bonding
- F Rinse-aid connection (optional)
- G Cleaning-agent connection (optional)
- H Air vent (2" internal diameter)
- I Dry air intake (2" internal diameter)
- J Gas connection
- K Exhaust outlet (2" internal diameter)
- M Safety overflow 3.2" x 1"
- N Ethernet connection RJ45 (optional)

10.4 Convotherm maxx pro 20.20 electrical unit

C4 20.20 dimensions and connection points (right-hinged unit door)

Front view

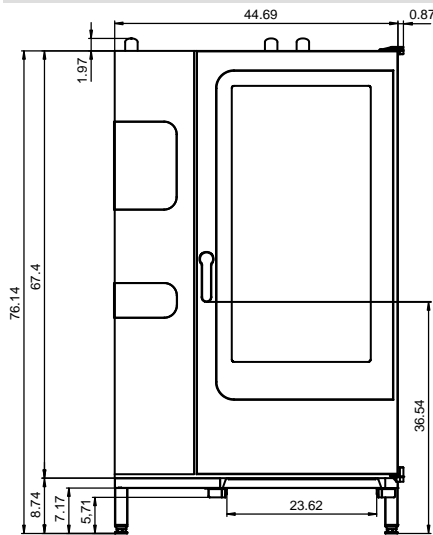

Connection points, unit floor

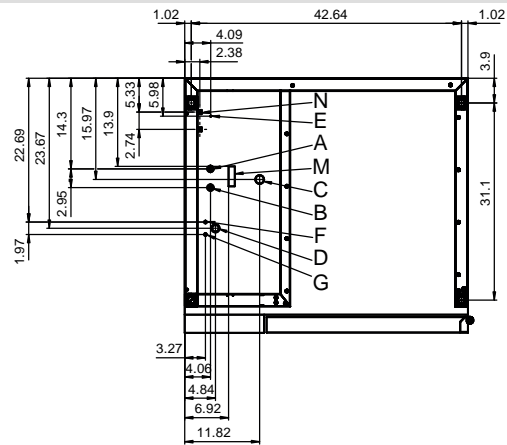

Drain connection detail

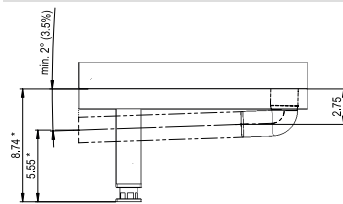

* The distance depends on how much the feet are extended (max. +0.984")

View from above with wall clearances

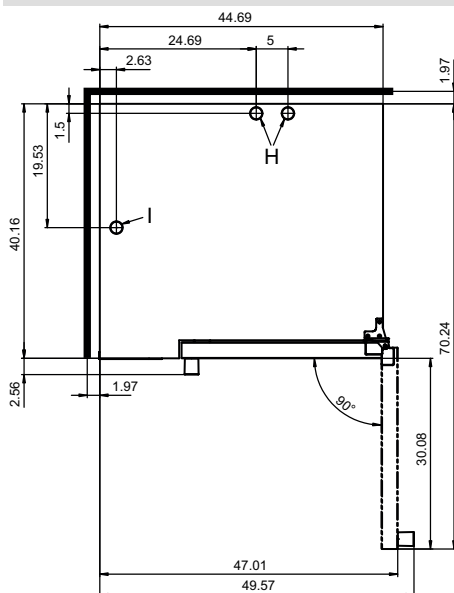

Key

- A Water connection (for boiler or water injection)
- B Water connection (for cleaning, recoil hand shower)
- C Drain connection (2" internal diameter)
- D Electrical connection
- E Bonding
- F Rinse-aid connection (optional)
- G Cleaning-agent connection (optional)
- H Air vent (2" internal diameter)
- I Dry air intake (2" internal diameter)
- M Safety overflow 3.2" x 1"
- N Ethernet connection RJ45 (optional)

C4 20.20 dimensions and connection points (disappearing door)

Front view

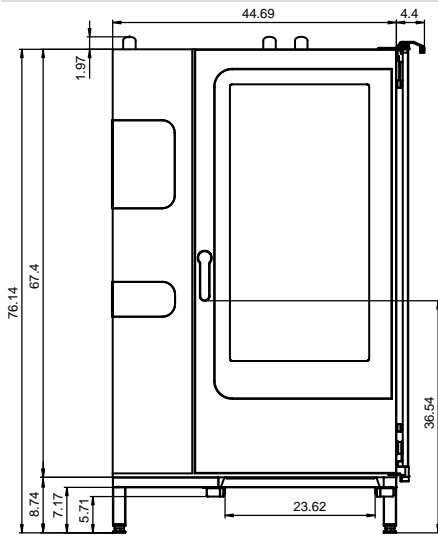

Connection points, unit floor

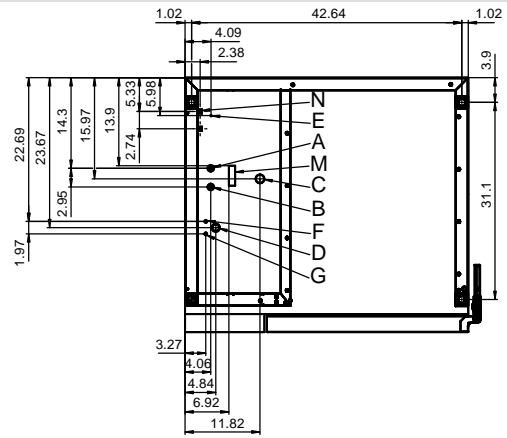

Drain connection detail

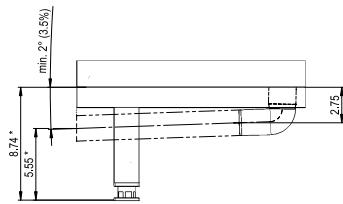

* The distance depends on how much the feet are extended (max. +0.984")

View from above with wall clearances

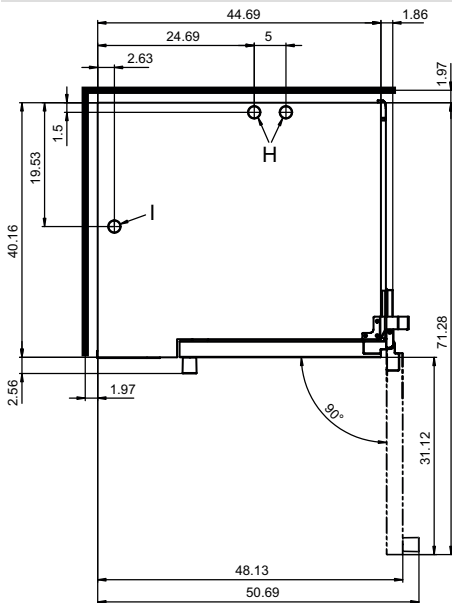

Key

- A Water connection (for boiler or water injection)
- B Water connection (for cleaning, recoil hand shower)
- C Drain connection (2" internal diameter)
- D Electrical connection
- E Bonding
- F Rinse-aid connection (optional)
- G Cleaning-agent connection (optional)
- H Air vent (2" internal diameter)
- I Dry air intake (2" internal diameter)
- M Safety overflow 3.2" x 1"
- N Ethernet connection RJ45 (optional)

10.5 Convotherm maxx pro 20.20 gas unit boiler

C4 20.20 dimensions and connection points (right-hinged unit door)

Front view

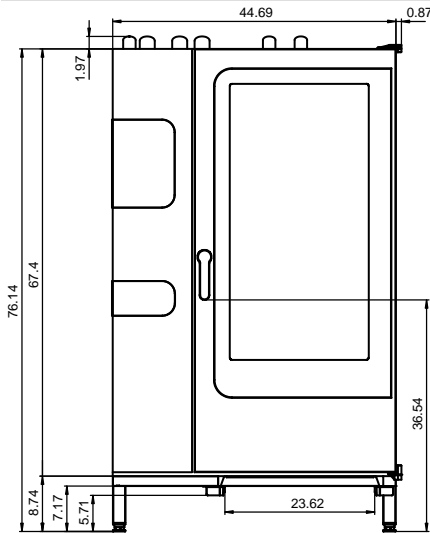

Connection points, unit floor

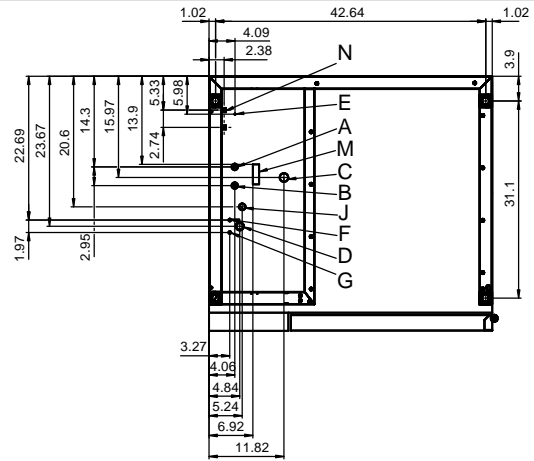

Drain connection detail

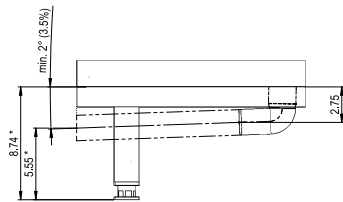

* The distance depends on how much the feet are extended (max. +0.984")

View from above with wall clearances

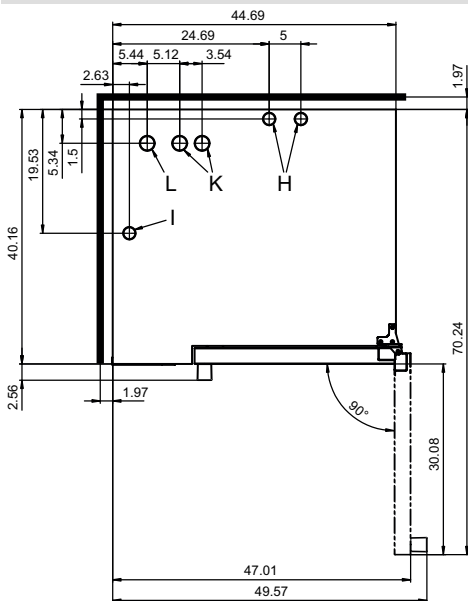

Key

- A Water connection (for boiler or water injection)
- B Water connection (for cleaning, recoil hand shower)
- C Drain connection (2" internal diameter)
- D Electrical connection
- E Bonding
- F Rinse-aid connection (optional)
- G Cleaning-agent connection (optional)
- H Air vent (2" internal diameter)
- I Dry air intake (2" internal diameter)
- J Gas connection
- K Convection burner exhaust outlet 2.37" internal diameter)
- L Boiler burner exhaust outlet (2.37" internal diameter)
- Safety overflow 3.2" x 1"
- M
- N Ethernet connection RJ45 (optional)

C4 20.20 dimensions and connection points (disappearing door)

Front view

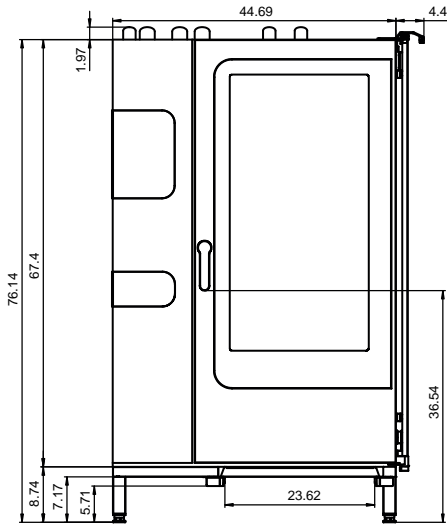

Connection points, unit floor

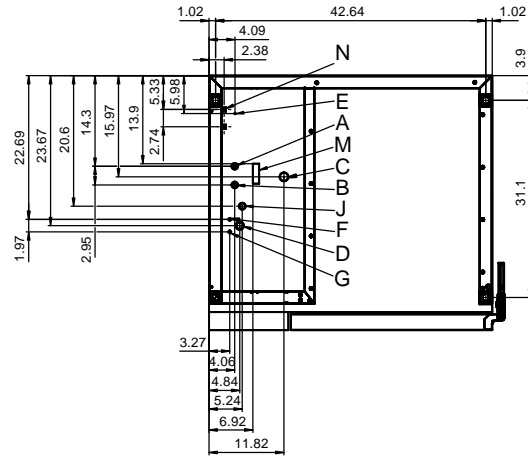

Drain connection detail

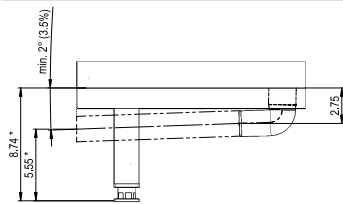

* The distance depends on how much the feet are extended (max. +0.984")

View from above with wall clearances

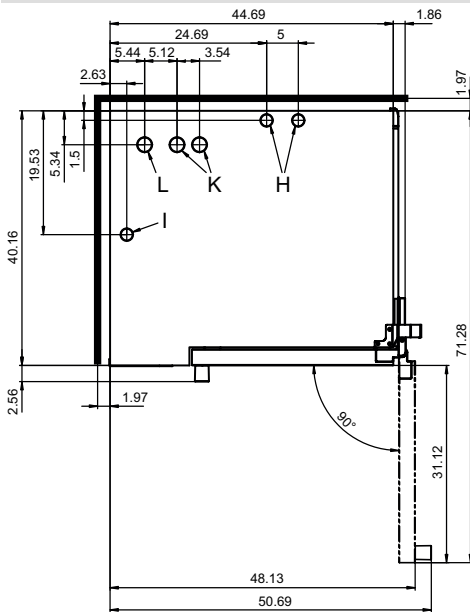

Key

- A Water connection (for boiler or water injection)
- B Water connection (for cleaning, recoil hand shower)
- C Drain connection (2" internal diameter)
- D Electrical connection
- E Bonding
- F Rinse-aid connection (optional)
- G Cleaning-agent connection (optional)
- H Air vent (2" internal diameter)
- I Dry air intake (2" internal diameter)
- J Gas connection
- K Convection burner exhaust outlet (2.37" internal diameter)
- L Boiler burner exhaust outlet (2.37" internal diameter)
- M Safety overflow 3.2" x 1"
- N Ethernet connection RJ45 (optional)

10.6 Convotherm maxx pro 20.20 gas unit water injection

C4 20.20 dimensions and connection points (right-hinged unit door)

Front view

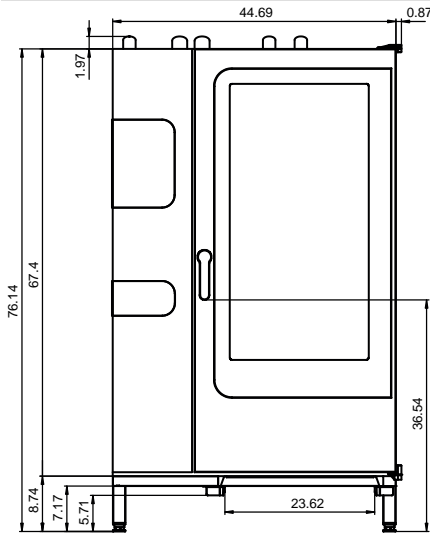

Connection points, unit floor

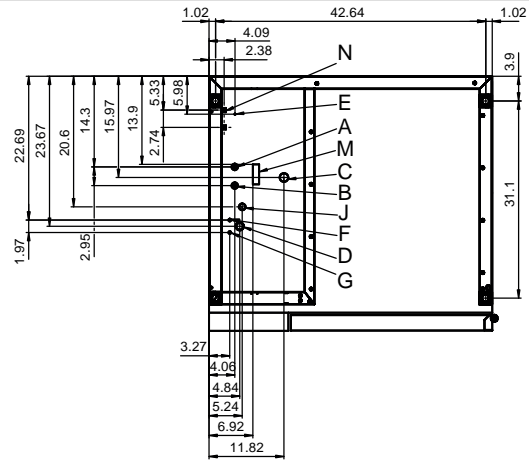

Drain connection detail

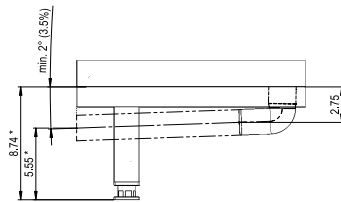

* The distance depends on how much the feet are extended (max. +0.984")

View from above with wall clearances

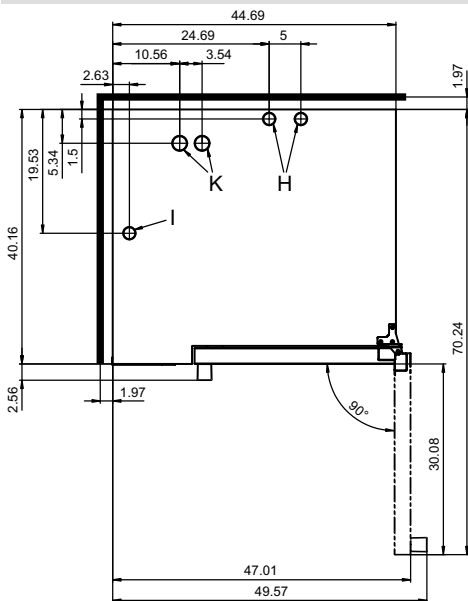

Key

- A Water connection (for boiler or water injection)
- B Water connection (for cleaning, recoil hand shower)
- C Drain connection (2" internal diameter)
- D Electrical connection
- E Bonding
- F Rinse-aid connection (optional)
- G Cleaning-agent connection (optional)
- H Air vent (2" internal diameter)
- I Dry air intake (2" internal diameter)
- J Gas connection
- K Exhaust outlet (2.37" internal diameter)
- M Safety overflow 3.2" x 1"
- N Ethernet connection RJ45 (optional)

C4 20.20 dimensions and connection points (disappearing door)

Front view

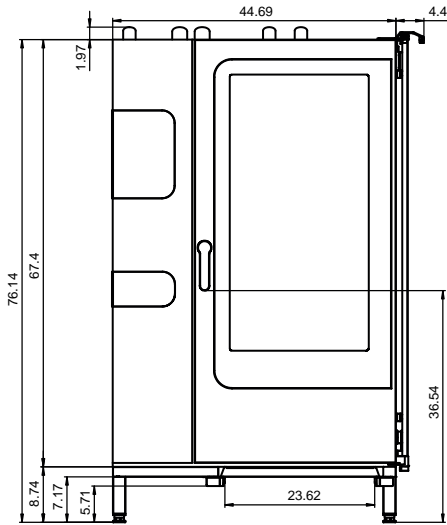

Connection points, unit floor

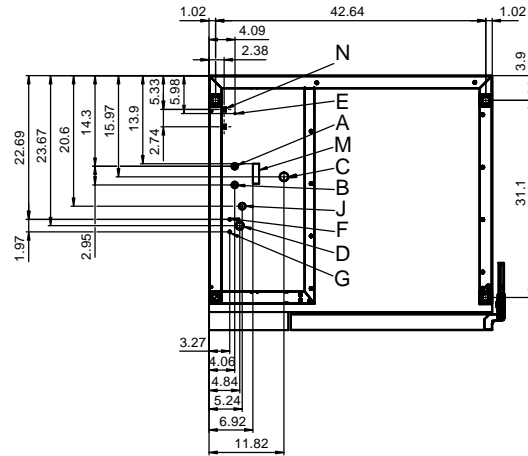

Drain connection detail

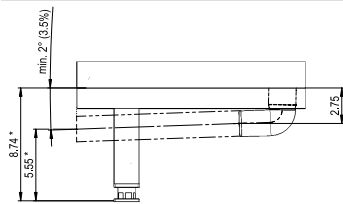

* The distance depends on how much the feet are extended (max. +0.984")

View from above with wall clearances

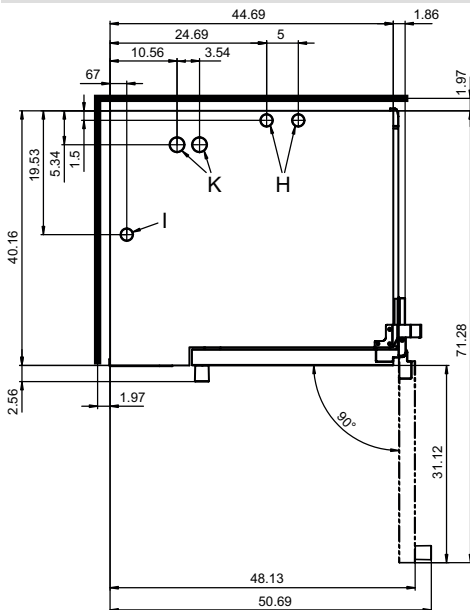

Key

- A Water connection (for boiler or water injection)
- B Water connection (for cleaning, recoil hand shower)
- C Drain connection (2" internal diameter)
- D Electrical connection
- E Bonding
- F Rinse-aid connection (optional)
- G Cleaning-agent connection (optional)
- H Air vent (2" internal diameter)
- I Dry air intake (2" internal diameter)
- J Gas connection
- K Exhaust outlet (2.37" internal diameter)
- M Safety overflow 3.2" x 1"
- N Ethernet connection RJ45 (optional)

Combi Oven
Convotherm maxx pro
Floor-standing models

Serial No.

Item no.

Order No.

Additional technical documentation can be found in the download center at :
www.convotherm.com



Welbilt's portfolio of award-winning brands includes **Cleveland™**, **Convotherm®**, **Crystal Tips®**, **Delfield®**, **Frymaster®**, **Garland®**, **Lincoln™**, **Merco®**, **Merrychef®**, **Multiplex®** and **Wmaxx™**. Supported by service brands: **KitchenCare®**, aftermarket service and **KitchenConnect®**, cloud-based open platform.

Bringing innovation to the table • welbilt.com