

TH2 (WATER)

TH1 (AIR)

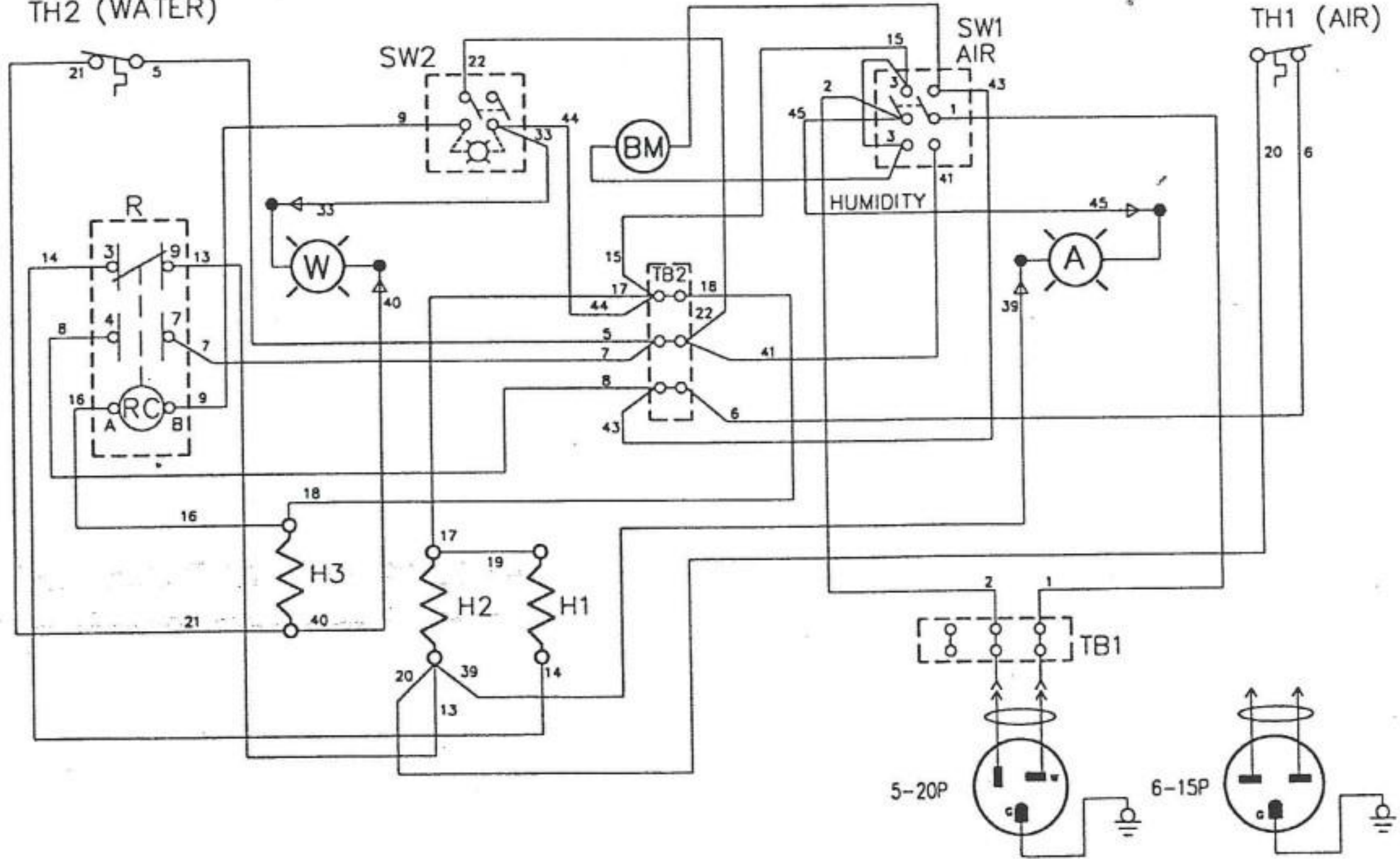

LEGEND

R	RELAY	SW2	SWITCH-BLOWER
W	PILOT LIGHT-WATER	TB1 & TB2	TERMINAL BLOCKS
A	PILOT LIGHT-AIR	TH 1	THERMOSTAT-AIR
H1 & H2	HEATERS-AIR	TH 2	THERMOSTAT-WATER
H3	HEATER-WATER	5-20P	PLUG 120V. 20A.
BM	BLOWER MOTOR	6-15P	PLUG 240V. 15A.
SW1	SWITCH-AIR-HUMIDITY	△	SLEEVING

ELECTRICAL SPECS.

MODEL #0747-035
120V, 2000W, 1Ph, 50/60Hz

MODEL #0747-036
240V, 2000W, 1Ph, 50/60Hz