

**INSTALLATION, OPERATION and MAINTENANCE
MANUAL for Cres Cor
CONVECTION and RETHERM OVENS**



**CO151F1818B
CO151FPUA12B
CO151FUA12B
RO151F1332B
RO151FUA18B**



**CO151H189B
CO151XUA5B
CO151X185B
CO151HUA6B**

Ovens	FL-2271
Rev. 9 (9/08)	Page 2 of 12

TABLE OF CONTENTS

SUBJECT	PAGE
INSTALLATION INSTRUCTIONS	3, 4
OPERATING INSTRUCTIONS	4, 5, 6
Illustration, Figure 1	4
MAINTENANCE INSTRUCTIONS	
How to Clean the Unit	5
Trouble Shooting Guide	6
Replacement Parts	7, 8
Illustrations; Hot Unit.	9, 10
Wiring Diagram	11, 12
STACKING INSTRUCTIONS.....	FL-2211
TIMER PROGRAMMING.....	FL-2222
SERVICE POLICY and AGENCY LIST	FL-1400



INSTALLATION INSTRUCTIONS

VENTING YOUR OVEN:

1. The purpose of ventilating hoods is to direct and capture smoke, grease-laden vapors, heat, odors, or fumes.
2. Low temperature equipment (maximum temperature 250°F/121°C) does not produce heat, odors, fumes, grease-laden vapors or smoke and is not required to be vented.
3. Most jurisdictions consider our low-temperature ovens (maximum temperature is 350°F/177°C) as low-heat appliances not requiring vent hoods.
4. Installation must conform with local codes. The authority having jurisdiction of enforcement of the codes will have the responsibility for making interpretations of the rules.

UNIT SPECIFICATIONS: All units use three (3) elements (2670 watts each). All units are rated 8200 watts.

MODEL NOS.	ELECTRICAL SPECS (AC SERVICE)			ELEC. LOAD		POWER SUPPLY REQUIREMENT ALL 3 PHASE IS 3 WIRE + GROUND			
	Volts	Ph	Hz.	Amps	Volts	Amps	Ph	Volts	NEMA
CONVECTION OVENS									
CO151FUA12B2081	208	1	60	39	208	50	1	208	6-50P
CO151FUA12B2401	240	1	60	34	240	50	1	240	6-50P
CO151FUA12B2083	208	3	60	23	208	30	3	208	L15-30P
CO151FUA12B2403	240	3	60	20	240	30	3	240	L15-30P
CO151F1818B2081	208	1	60	39	208	50	1	208	6-50P
CO151F1818B2401	240	1	60	34	240	50	1	240	6-50P
CO151F1818B2083	208	3	60	23	208	30	3	208	L15-30P
CO151F1818B2403	240	3	60	20	240	30	3	240	L15-30P
REThERM OVENS									
RO151FUA18B2081	208	1	60	39	208	50	1	208	6-50P
RO151FUA18B2401	240	1	60	34	240	50	1	240	6-50P
RO151FUA18B2083	208	3	60	23	208	30	3	208	L15-30P
RO151FUA18B2403	240	3	60	20	240	30	3	240	L15-30P
RO151F1332B2081	208	1	60	39	208	50	1	208	6-50P
RO151F1332B2401	240	1	60	34	240	50	1	240	6-50P
RO151F1332B2083	208	3	60	23	208	30	3	208	L15-30P
RO151F1332B2403	240	3	60	20	240	30	3	240	L15-30P
HALF-SIZE OVENS Are rated at 4700 watts (Three [3] heaters at 1470 watts each)									
CO151HUA6B2081	208	1	60	23	208	30	1	208	6-30P
CO151HUA6B2401	240	1	60	20	240	30	1	240	6-30P
CO151HUA6B2083	208	3	60	13	208	20	3	208	L15-20P
CO151HUA6B2403	240	3	60	12	240	20	3	240	L15-20P
CO151H189B2081	208	1	60	23	208	30	1	208	6-30P
CO151H189B2401	240	1	60	20	240	30	1	240	6-30P
CO151H189B2083	208	3	60	13	208	20	3	208	L15-20P
CO151H189B2403	240	3	60	12	240	20	3	240	L15-20P
CO151XUA5B2081	208	1	60	23	208	30	1	208	6-30P
CO151XUA5B2401	240	1	60	20	240	30	1	240	6-30P
CO151XUA5B2083	208	3	60	13	208	20	3	208	L15-20P
CO151XUA5B2403	240	3	60	12	240	20	3	240	L15-20P
CO151X185B2081	208	1	60	23	208	30	1	208	6-30P
CO151X185B2401	240	1	60	20	240	30	1	240	6-30P
CO151X185B2083	208	3	60	13	208	20	3	208	L15-20P
CO151X185B2403	240	3	60	12	240	20	3	240	L15-20P

All models are designed for AC Service. Model numbers may have the letters: P, L, M, Z, T or S.

Ovens	FL-2271
Rev. 9 (9/08)	Page 4 of 12

INSTALLATION INSTRUCTIONS (continued)

HOW TO INSTALL CABINETS:

1. Remove all packing material from inside and outside of cabinet.
2. Position cabinet on level floor; install the cabinet interior (pan slides) if not already installed.
3. Plug power cord into proper wall receptacle.

NOTE: Cold food is **NOT** to be added when unit is operating on **HOLD** mode.

For **HOLD** mode, preheat unit to 180°F/82°C for 60 minutes.



To install stacking units, refer to instruction sheet FL-2211, **Stacking Installation.**

OPERATING INSTRUCTIONS

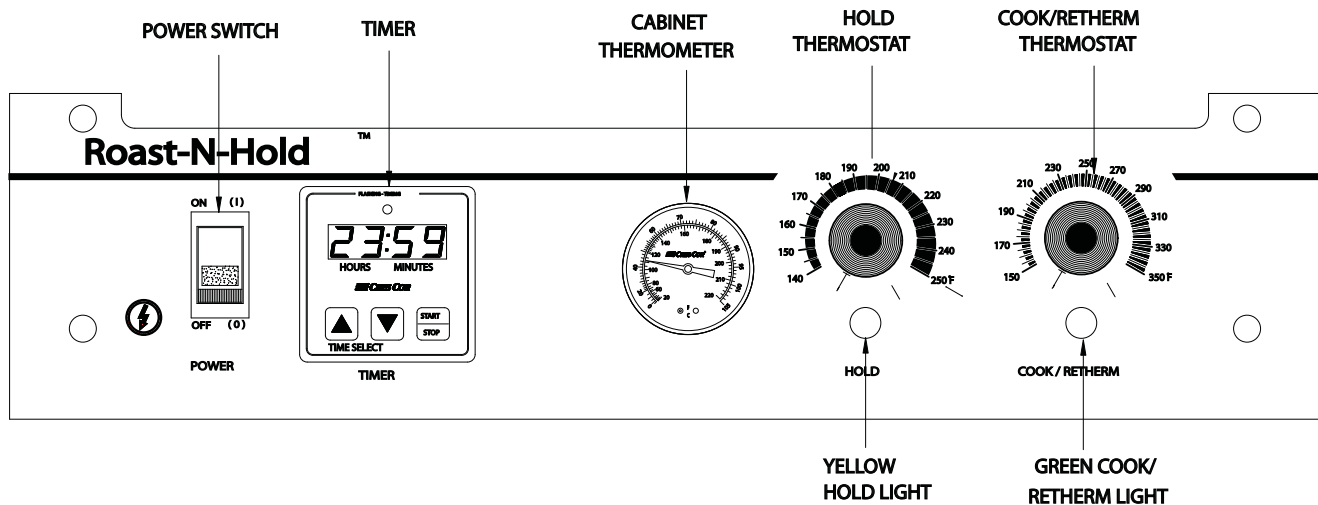

HOW TO SET TIMER:

- A. Press the **UP** arrow-button (on the TIMER) to increase the time. The longer the button is held down, the faster the time will increase. Pressing the **DOWN** arrow-button (using the same method) will cause the time to decrease.
- B. Press **START/STOP** button on Timer to begin cooking cycle. GREEN roast light will light up. Timer will count down to 0.00. The timing light on the timer will flash.
- C. Cooking time can be changed while oven is in any mode.
 - (1) Press **START/STOP** button.
 - (2) Adjust time by using **UP** and **DOWN** arrow-buttons.
 - (3) Press **START/STOP** button to restart oven.

HOW TO START UNIT

(for first-time operation only)

A new oven needs to “burn off” factory oils and glue before it’s first use. **Do NOT load food into oven until this has been done!**

1. Push switch to “ON”.
2. Set the **Cook/Retherm** thermostats to 350°F/177°C.
3. Set the **Hold** thermostat to 150°F/66°C.
4. Set the timer to one (1) hour.
5. Allow oven to run automatically for one (1) hour of **Cook/Retherm** cycle and 30 minutes of **Hold** cycle.

HOW TO START UNIT

(After first-time operation):

Push **POWER** switch “ON”.

For Automatic Operation:

1. Set *Cook/Retherm* thermostat to the cooking temperature you need.
2. Set *Hold* thermostat to the warming temperature you need. Proper food holding temperature is 140°F/60°C or higher.
3. Set *Timer* for the roasting time. The unit will automatically switch to the pre-set “hold” temperature after roasting time has expired.

For Holding Operation ONLY:

NOTES: For **HOLD** mode, preheat unit to 180°F/82°C for 60 minutes.

Cold food is **NOT** to be added when unit is operating in **HOLD** mode.

1. Set **HOLD** thermostat to the temperature you need.
2. Set **Timer** at zero.

TO SHUT DOWN UNIT:

Push **SWITCH** to “OFF”.

NOTE: Ventilating fans will continue to run until cabinet is cool. Do **NOT** disconnect the power supply to the cabinet while the ventilating fan is still operating.

HOW TO CLEAN THE UNIT:

WARNING

BEFORE cleaning the cabinet:

1. **Unplug cord from wall. Allow cabinet to cool.**
2. **Do NOT hose cabinet with water.**
3. **Do NOT get water on controls.**
4. **Do NOT use abrasives or harsh chemicals.**
 - Wipe up spills as soon as possible.
 - Clean regularly to avoid heavy dirt build-up.

Cleaning Hints:

1. Use the mildest cleaning procedure that will do the job.
2. Always rub in the direction of polish lines to avoid scratching the surface.
3. Use only a soft cloth, sponge, fibrous brushes, plastic or stainless steel pads for cleaning and scouring.
4. Rinse thoroughly with fresh water after every cleaning operation.
5. Always wipe dry to avoid water marks.

	SOIL	CLEANER	METHOD
CABINET Inside and Outside (Stainless Steel)	Routine Cleaning	Soap, ammonia or mild detergent* and water.	1. Sponge on with cloth 2. Rinse
	Stubborn Spots, Stains	Mild abrasive made for Stainless Steel.	1. Apply with damp sponge or cloth. 2. Rub lightly.
	Burnt on Foods or Grease	Chemical oven cleaner made for Stainless Steel.	Follow oven cleaner manufacturer's directions.
	Hard Water Spots & Scale	Vinegar	1. Swab or wipe with cloth. 2. Rinse and dry.
*MILD DETERGENTS INCLUDE SOAPS AND NON-ABRASIVE CLEANERS.			

Ovens	FL-2271
Rev. 9 (9/08)	Page 6 of 12

MAINTENANCE INSTRUCTIONS TROUBLE-SHOOTING GUIDE

WARNING

IF UNIT GETS TOO HOT OR WON'T SHUT OFF, DISCONNECT POWER AT BRANCH PANEL. DO NOT UNPLUG CORD!

If hot unit is *NOT* working, first check the following causes:

- | | |
|--|---|
| 1. Cord is unplugged from wall outlet. | 3. Switch is turned off. |
| 2. Circuit breaker/fuse to wall outlet is blown. | 4. Thermostat is turned off, or is set too low. |

PROBLEM	POSSIBLE CAUSE	SOLUTION
Cabinet does not heat, or doesn't heat properly	1. Fuse 2. Control 3. Sensor 4. Heater contactor 5. Loose wiring at heater contactor 6. On/Off Switch	1. Replace 2. Replace 3. Replace 4. Replace 5. Replace 6. Replace
Blowers do not operate	1. On/Off Switch 2. Fuse 3. Blower	1. Replace 2. Replace 3. Replace
Heaters will not shut off	1. Thermostat defective 2. Contactor defective	1. Replace 2. Replace
Vent fans do not shut off	1. Vent fan switch defective 2. Control compartment is still hot.	1. Replace 2. Wait until it cools Check "Heaters will not shut off"
Vent fans do not operate (See Note)	1. Fuse 2. Vent fan switch defective 3. Vent fan defective	1. Replace 2. Replace 3. Replace

NOTE: Vent fans will not operate until the control compartment requires ventilation to limit temperatures. Replacement of electrical components must be done by a qualified electrician. Refer to our *Service Agency list, FL-1400* (found in the back of this manual), of authorized service centers. Instructions for replacing parts are included in replacement parts list.

REPLACEMENT PARTS

Include all information on nameplate when ordering parts

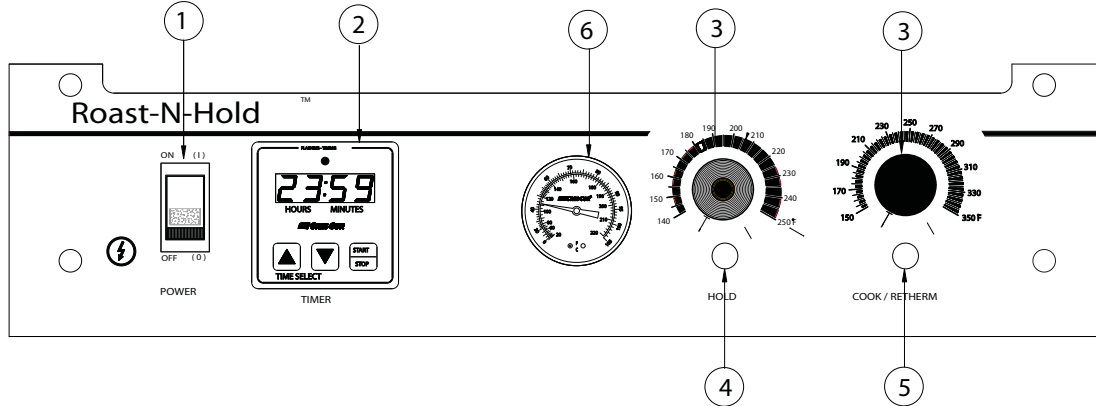

Hot Unit Replacement Parts

ITEM DESCRIPTION

Part No.

1. Switch (On/Off)	0808-113-01-K
2. Timer, Digital	0849-088-K
Timer, Digital with Transformer	0849-088-K2
3. Knob, Thermostat	0595-061
3. Control Board Kit	0848-057-K3
Potentiometer Only	0848-057-04
4. Pilot Light, Yellow	0766-095
5. Pilot Light, Green	0766-097
6. Thermometer	5238-031
7. Vent Fan	0769-174
8. Fan Guard	0769-167
9. Fuse (Before 7/08)	0807-058
Fuse Holder (Before 7/08)	0807-048
Fuse	0807-151
Fuse Holder	0807-150
10. Blower Kit	0769-182-K
11. Contactor	0857-026
12. Terminal Block, Front	0852-096
13. Terminal Block	0852-093
14. Switch, Fan	0848-034
15. Relay, Timer	0857-102
16. Hi-Limit (Switch)	0848-079
17. Sensor Only	0848-058-K1
Sensor Bushing	0818-014
18. Transformer	0769-159

ITEM DESCRIPTION

Part No.

PARTS for 8200W, 1-PH UNITS

19. Power Cord	0810-124
Power Cord (Pass-thru)	0810-161
20. Heater Kit, 208V	0811-261
Heater Kit, 240V	0811-262
21. Strain Relief	0818-061

PARTS for 8200W, 3-PH UNITS

19. Power Cord	0810-132
Power Cord (Pass-thru)	0810-162
20. Heater Kit, 208V	0811-261
Heater Kit, 240V	0811-262
21. Strain Relief	0818-050

PARTS for 4700W, 1-PH UNITS

19. Power Cord	0810-163
20. Heater Kit, 240V	0811-020-K
Heater Kit, 208V	0811-020-01-K
21. Strain Relief	0818-050

PARTS for 4700W, 3-PH UNITS

19. Power Cord	0810-164
20. Heater Kit, 240V	0811-020-K
Heater Kit, 208V	0811-020-01-K
21. Strain Relief	0818-050

Ovens	FL-2271
Rev. 9 (9/08)	Page 8 of 12



REPLACEMENT PARTS

Include all information on nameplate when ordering parts

FULL-SIZE CABINET REPLACEMENT PARTS

DESCRIPTION	MODEL PREFIX CO-151 or RO-151			
	-FUA (12, 18B)	-FPUA	-F18 (18B)	-F1332
Hot Unit, 208V, 1 Ph	HU675017	HU675062	HU675021	HU675058
Hot Unit, 240V, 1 Ph	HU675018	HU675063	HU675022	HU675059
Hot Unit, 208V, 3 Ph	HU675019	HU675064	HU675023	HU675060
Hot Unit, 240V, 3 Ph	HU675020	HU675065	HU675024	HU675061
Door Latch Kit	1006-120-01-K	1006-120-01-K	1006-120-01-K	1006-120-01-K
Latch Strike	1006-120-02-K	1006-120-02-K	1006-120-02-K	1006-120-02-K
Door Hinge	0519-074-K	0519-074-K	0519-074-K	0519-074-K
Door Assembly	1221-525-K	1221-525-K	1221-541-K	1221-543-K
Door Gasket	0861-185-K	0861-185-K	0861-197-K	0861-184
Interior	0621-281-K	0621-281-K	1104-106	1104-108
Side Handles (2), Black Recessed	0911-102	0911-102	0911-102	0911-102

HALF-SIZE CABINET REPLACEMENT PARTS

DESCRIPTION	MODEL PREFIX CO-151 or RO-151			
	-HUA, (6B)	-H18 (9B)	-X185B	-XUA5B
Hot Unit, 208V, 1 Ph	HU675033	HU675041	HU675041	HU675033
Hot Unit, 240V, 1 Ph	HU675034	HU675042	HU675042	HU675034
Hot Unit, 208V, 3 Ph	HU675035	HU675043	HU675043	HU675035
Hot Unit, 240V, 3 Ph	HU675036	HU675044	HU675044	HU675036
Door Latch Kit	1006-120-01-K	1006-120-01-K	1006-120-01-K	1006-120-01-K
Latch Strike	1006-120-02-K	1006-120-02-K	1006-120-02-K	1006-120-02-K
Door Hinge	0519-074-K	0519-074-K	0519-074-K	0519-074-K
Door Assembly	1221-525-K	1221-541-K	1221-546-K	1221-545-K
Door Gasket	0861-185-K	0861-197-K	0861-251	0861-250-K
Interior	0621-281-K	1104-106	1104-107	0621-281-K

REPLACEMENT PARTS
for OVENS CO or RO151F SERIES
Include all information on nameplate when ordering parts

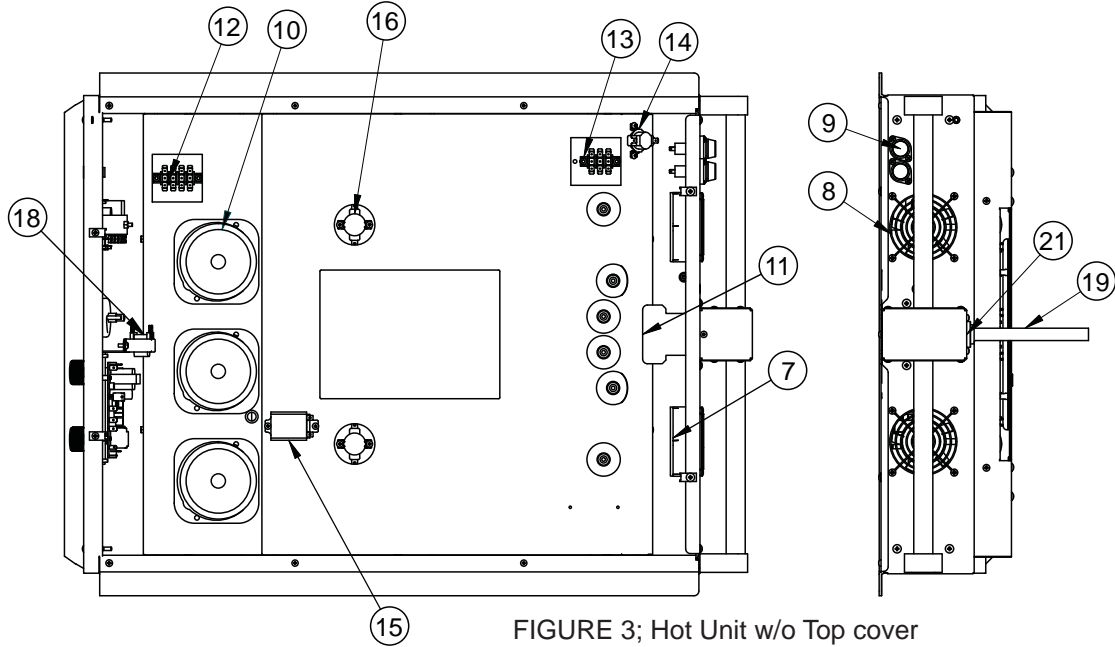

FIGURE 3; Hot Unit w/o Top cover
 (For parts description, refer to page 7.)

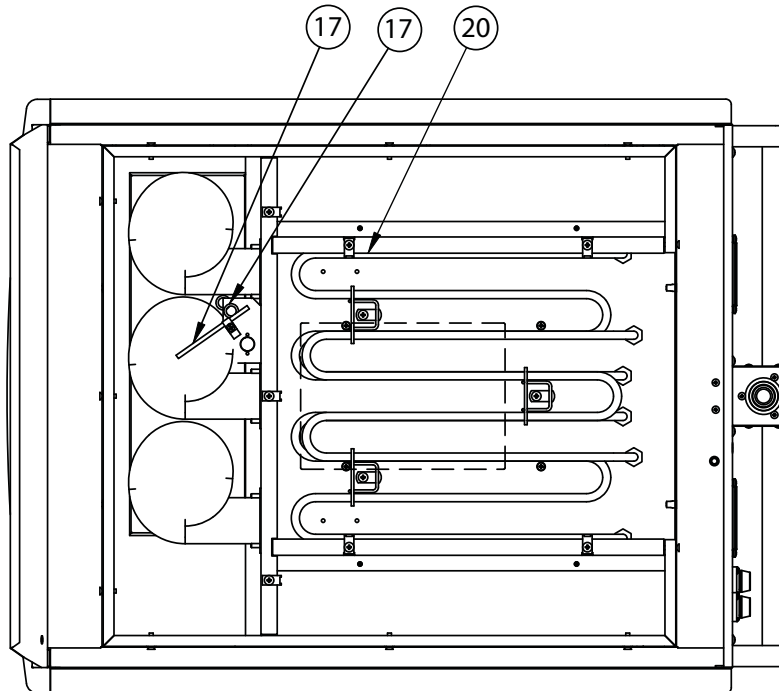

FIGURE 4; Bottom of Hot Unit, Cover Removed
 (For parts description, refer to page 7.)

Ovens	FL-2271
Rev. 9 (9/08)	Page 10 of 12

REPLACEMENT PARTS
for "PASS-THRU" OVENS CO or RO151FPUA SERIES
Include all information on nameplate when ordering parts

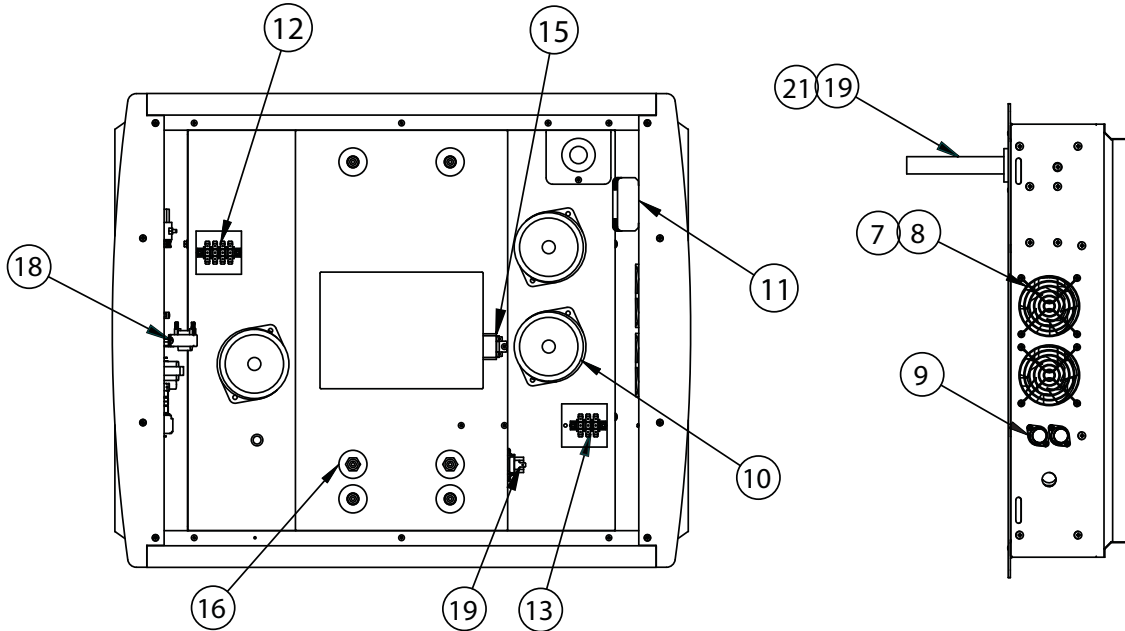

FIGURE 3; Hot Unit w/o Top cover
 (For parts description, refer to page 7.)

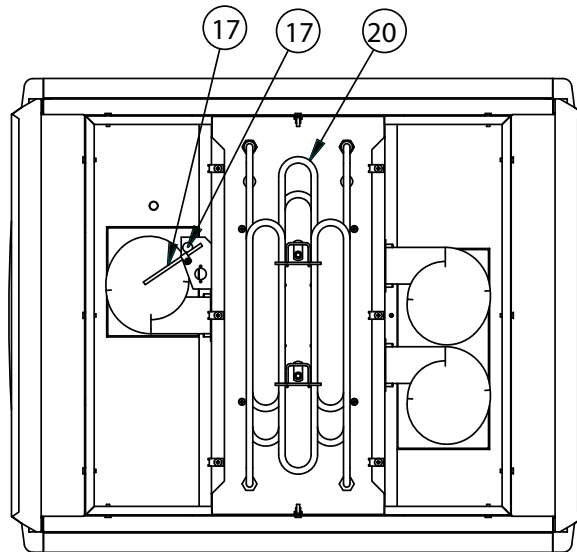
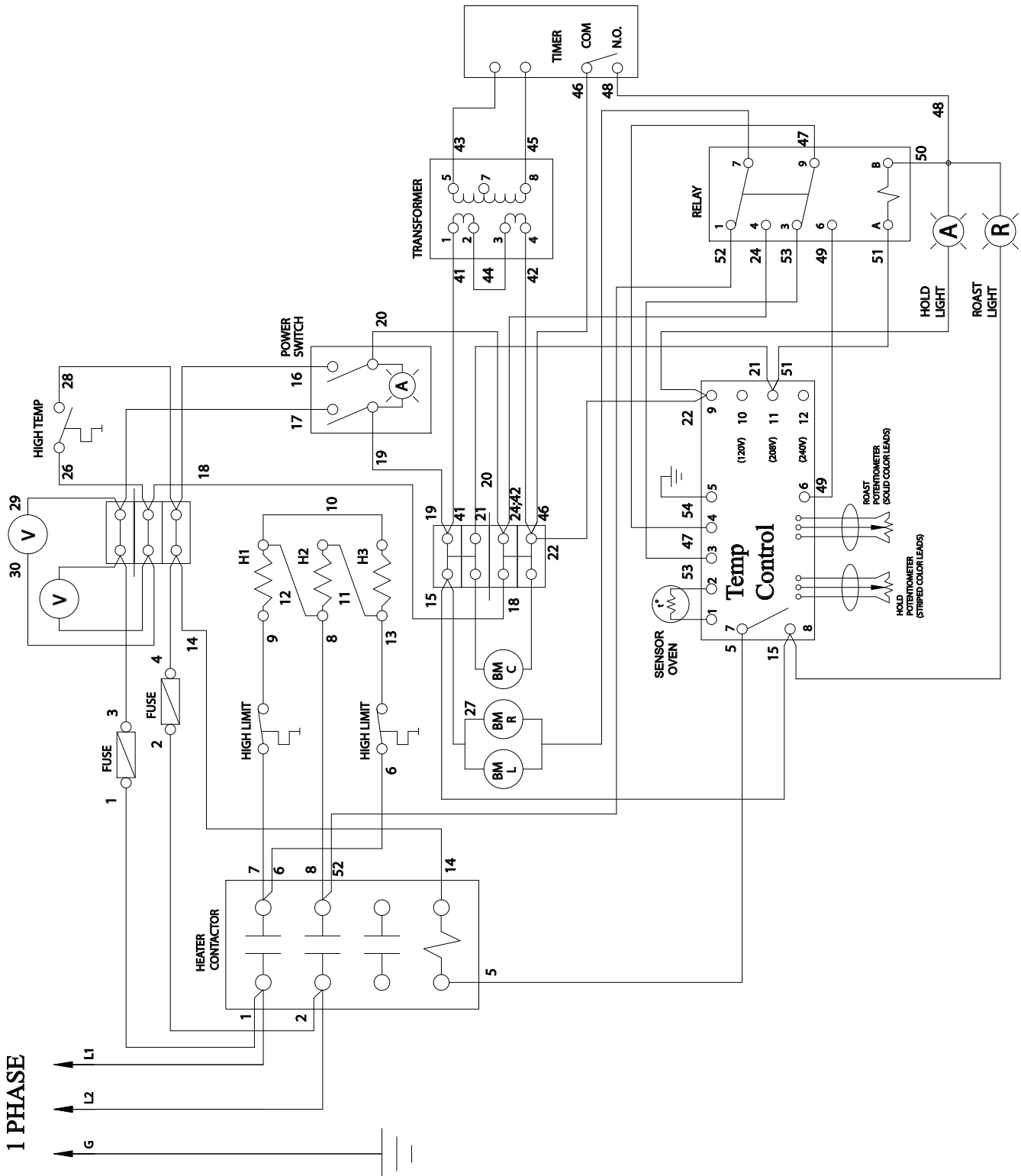

FIGURE 4; Bottom of Hot Unit, Cover Removed
 (For parts description, refer to page 7.)

WIRING DIAGRAM SINGLE PHASE



SINGLE PHASE

Ovens	FL-2271
Rev. 9 (9/08)	Page 12 of 12

WIRING DIAGRAM THREE PHASE

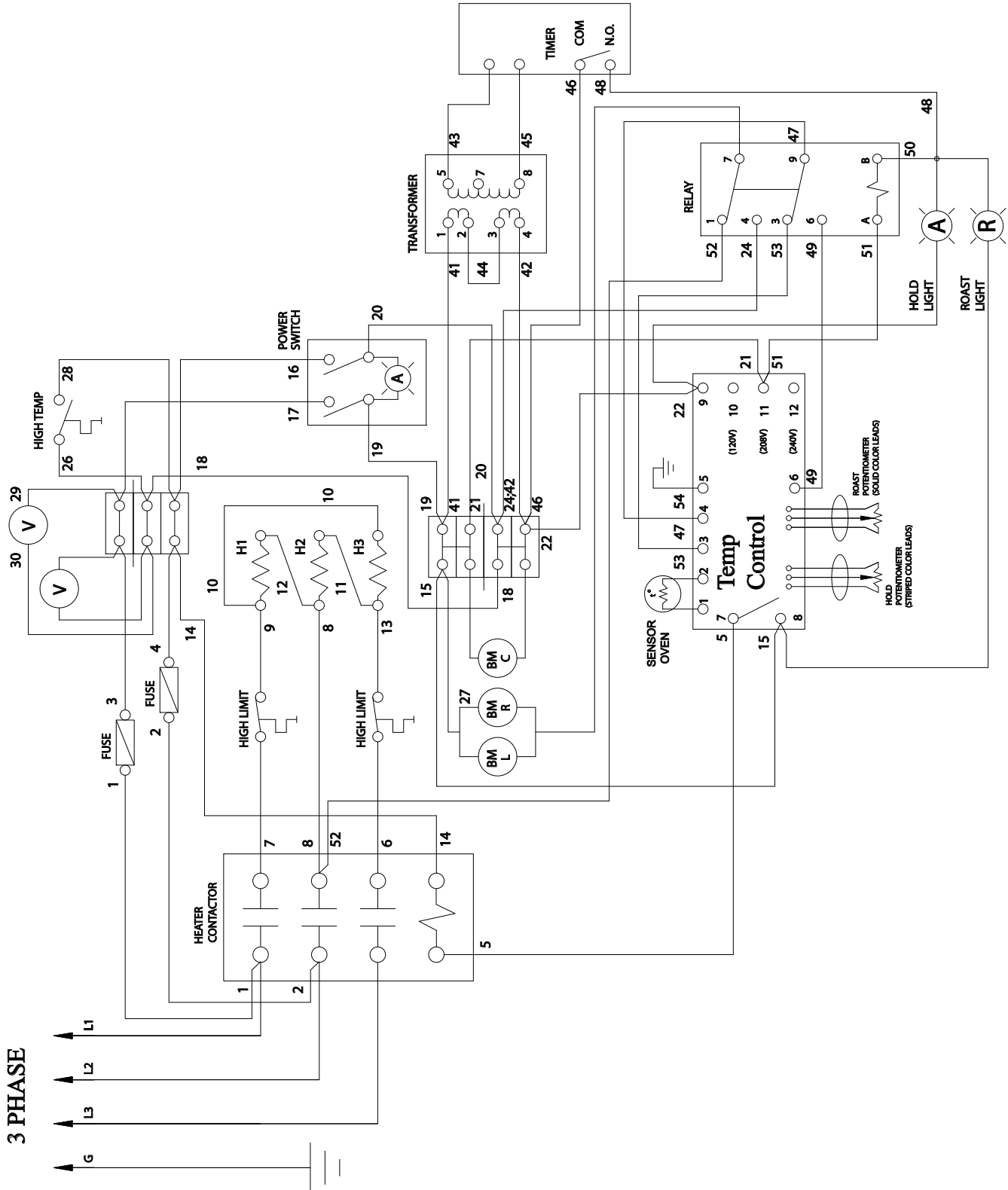

THREE PHASE