

**INSTALLATION, OPERATION and MAINTENANCE
MANUAL for Cres Cor
AQUATEMP HUMIDITY
CONVECTION and RETHERM OVENS**



**CO151FWUA12B
CO151FW1818B
CO151FPWUA12B
RO151FWUA18B**



**CO151HWUA6B
CO151HW189B
CO151XWUA5B
CO151XW185B**

Ovens	FL-2270
Rev. 12 (6/10)	Page 2 of 13

TABLE OF CONTENTS

SUBJECT	PAGE
INSTALLATION INSTRUCTIONS	3
OPERATING INSTRUCTIONS	4, 5
Illustration, Figure 1	4
MAINTENANCE INSTRUCTIONS	
How to Clean the Unit	6
Trouble Shooting Guide	7, 8
Replacement Parts	8, 9
Illustrations; Hot Unit (Figures 4 and 5)	10, 11
Wiring Diagram (Single Phase)	12
Wiring Diagram (Three Phase)	13
TIMER PROGRAMMING	FL-2222
SERVICE POLICY and AGENCY LIST	FL-1400

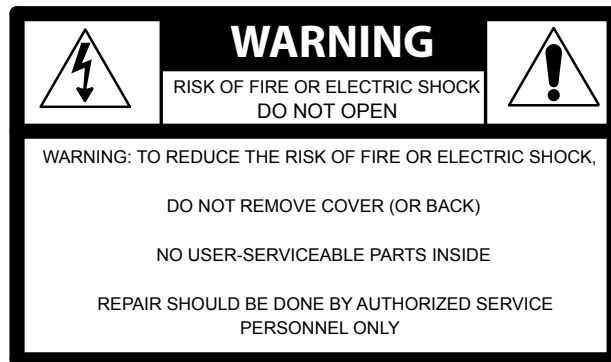

INSTALLATION INSTRUCTIONS

VENTING YOUR OVEN:

1. The purpose of ventilating hoods is to direct and capture smoke, grease-laden vapors, heat, odors, or fumes.
2. Low temperature equipment (maximum temperature 250°F/121°C) does not produce heat, odors, fumes, grease-laden vapors or smoke and is not required to be vented.
3. Most jurisdictions consider our low-temperature ovens (maximum temperature is 350°F/177°C) as low-heat appliances not requiring vent hoods.
4. Installation must conform with local codes. The authority having jurisdiction of enforcement of the codes will have the responsibility for making interpretations of the rules.

UNIT SPECIFICATIONS: All units use three (3) elements (2670 watts each).

All units are rated 8200 watts. Water units have one (1) immersion element (1850 watts).

MODEL NOS.	ELECTRICAL SPECS (AC SERVICE)			ELEC. LOAD		POWER SUPPLY REQUIREMENT ALL 3 PHASE IS 3 WIRE + GROUND			
	Volts	Ph	Hz.	Amps	Volts	Amps	Ph	Volts	NEMA
CONVECTION OVENS									
CO151FWUA12B2081	208	1	60	39	208	50	1	208	6-50P
CO151FWUA12B2401	240	1	60	34	240	50	1	240	6-50P
CO151FWUA12B2083	208	3	60	23	208	30	3	208	L15-30P
CO151FWUA12B2403	240	3	60	20	240	30	3	240	L15-30P

REThERM OVENS

RO151FWUA18B2081	208	1	60	39	208	50	1	208	6-50P
RO151FWUA18B2401	240	1	60	34	240	50	1	240	6-50P
RO151FWUA18B2083	208	3	60	23	208	30	3	208	L15-30P
RO151FWUA18B2403	240	3	60	20	240	30	3	240	L15-30P
RO151FW1332B2081	208	1	60	39	208	50	1	208	6-50P
RO151FW1332B2401	240	1	60	34	240	50	1	240	6-50P
RO151FW1332B2083	208	3	60	23	208	30	3	208	L15-30P
RO151FW1332B2403	240	3	60	20	240	30	3	240	L15-30P

HALF-SIZE OVENS Are rated at 4700 watts (Three [3] heaters at 1470 watts each)

CO151HWUA6B2081	208	1	60	24	208	30	1	208	6-30P
CO151HWUA6B2401	240	1	60	21	240	30	1	240	6-30P
CO151HWUA6B2083	208	3	60	15	208	20	3	208	L15-20P
CO151HWUA6B2403	240	3	60	13	240	20	3	240	L15-20P
CO151XWUA5B2081	208	1	60	24	208	30	1	208	6-30P
CO151XWUA5B2401	240	1	60	21	240	30	1	240	6-30P
CO151XWUA5B2083	208	3	60	15	208	20	3	208	L15-20P
CO151XWUA5B2403	240	3	60	13	240	20	3	240	L15-20P

*All models are designed for AC Service. Model numbers may have the letters: **P, L, M, Z** or **S**.*

OPERATING INSTRUCTIONS

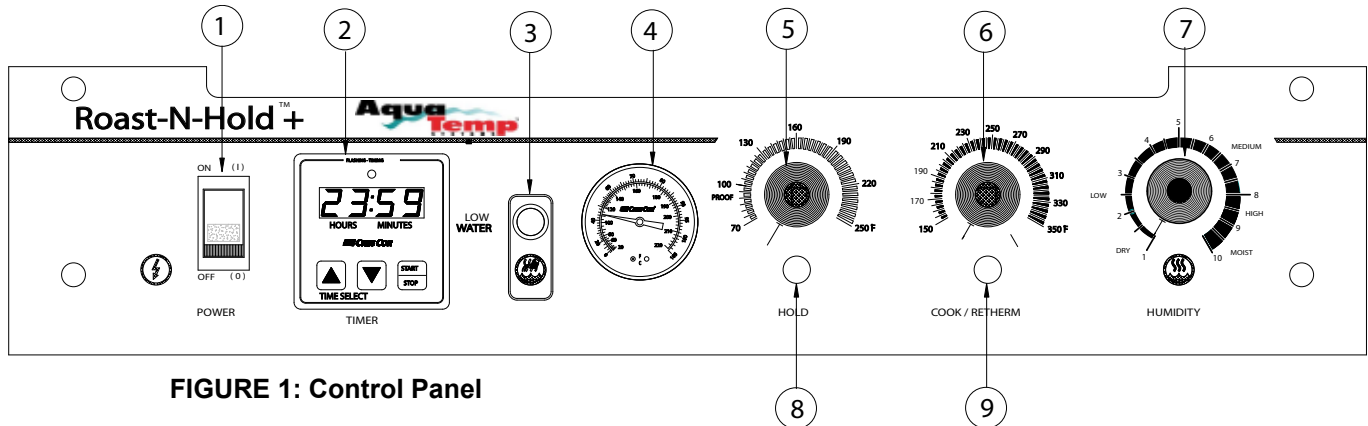

FIGURE 1: Control Panel

PARTS DESCRIPTION

- | | |
|------------------------|---------------------------------|
| 1. Switch – “ON-OFF” | 6. Thermostat – “Cook/Retherm” |
| 2. Timer – Digital | 7. Thermostat – “Humidity” |
| 3. “Low Water” Light | 8. Yellow Light – “Hold” |
| 4. Thermometer | 9. Green Light – “Cook/Retherm” |
| 5. Thermostat – “Hold” | |

HOW TO INSTALL CABINETS:

1. Remove all packing material from inside and outside of cabinet.
2. Position cabinet on level floor; install the cabinet interior (pan slides) if not already installed.
3. Plug power cord into proper wall receptacle.
4. Fill water pan with three (3) gallons of HOT water. (See CAUTION).

HOW TO SET TIMER:

- A. Press the **UP** arrow button (on the TIMER) to increase the time. The longer the button is held down, the faster the time will increase. Pressing the **DOWN** arrow button (using the same method) will cause the time to decrease.
- B. Press **START/STOP** button on Timer to begin cooking cycle. GREEN roast light will light up. Timer will count down to 0.00. The timing light on the timer will flash.
- C. Cooking time can be changed while oven is in any mode.
 - (1) Press **START/STOP** button.
 - (2) Adjust time by using **UP** and **DOWN** arrow-buttons.
 - (3) Press **START/STOP** button to restart oven.

LOW WATER LIGHT:

When water needs to be added to the pan, the *Low Water Light* will stay on until the pan is refilled.

CAUTION

Use of treated water is recommended for proper operation and to maintain warranty. It will reduce scaling.
HOW TO START UNIT

(for first-time operation only)

A new oven needs to “burn off” factory oils and glue before it’s first use. **Do NOT load food into oven until this has been done!**

1. Push switch to “ON”.
2. Set the *Cook/Retherm* thermostats to 350°F/177°C.
3. Set the *Hold* thermostat to 150°F/66°C.
4. Set the timer to one (1) hour.
5. Allow oven to run automatically for one (1) hour of *Cook/Retherm* cycle and 30 minutes of *Hold* cycle.

WARNING

Air is VERY HOT when door is opened.

NOTE: Cold food is **NOT** to be added when unit is operating on *HOLD* mode.

OPERATING INSTRUCTIONS (continued)

HOW TO START UNIT

(After first-time operation):

Push **POWER** switch “ON”.

Preheat:

In **HOLD** mode, preheat unit to 180°F/82°C for 60 minutes.

STANDARD OPERATION

1. Set **Cook/Retherm** thermostat to the cooking temperature you need.
2. Set **Hold** thermostat to the warming temperature you need after the cook cycle. Proper food holding temperature is 140°F/60°C or higher.
3. Set **Timer** for the cooking time. Press timer start button. The oven will automatically switch to the pre-set hold temperature after cooking time has expired.

COOK (HUMIDITY) OPERATION

HOW TO COOK:

1. Set Cook/Retherm thermostat to the cooking temperature you need.
2. Set Hold thermostat to the warming temperature you need after the cook cycle.

HOW TO COOK, *continued*

3. Set **Humidity** control to the desired relative humidity you need in the oven. This setting is for both **COOK** and **HOLD** cycles.
4. Set **Timer** for the cooking time. Press timer start button. The oven will automatically switch to the pre-set hold temperature after cooking time has expired.

HOW TO PROOF:

1. Fill the water pan with three (3) gallons of **HOT** water.
2. Set the **Humidity** control at low to mid-range.
3. Set the **Hold** control to **Proof**.
4. Preheat the oven at this setting for ½ hour.
5. Put in product. **DO NOT** use frozen product.
6. Listed below are typical thermostat settings. Experiment with different settings to get the temperature and humidity that you need.

TO SHUT DOWN UNIT:

Push **POWER** switch to “OFF”.

NOTE: Ventilating fans will continue to run until cabinet is cool. Do NOT disconnect the power supply to the cabinet while the ventilating fan is still operating.

TEMPERATURE / HUMIDITY SETTINGS

HOLD Dial Setting	HUMIDITY Dial Setting									
	Temp., °F/°C	1	2	3	4	5	6	7	8	9
140/60	15	20	25	35	50	65	85	100	100	100
150/66	10	15	20	25	35	55	70	100	100	100
160/71	5	10	15	20	30	40	60	80	100	100
180/82	5	5	10	15	20	25	30	50	70	95
200/93	5	5	5	10	15	20	25	35	50	75

Values Listed are % Relative Humidity.

NOTE: Cold food is **NOT** to be added to the unit when operating in the **HOLD** mode.

OPERATING INSTRUCTIONS (continued)

MAINTENANCE: WATER PAN

Drain, wipe and fill water pan daily. (Clear vinyl drain-hose is provided).

1. Push hose into drain nozzle under the base.
2. Turn knob to open the drain.

To Fully Dry Out:

1. Drain until 1/8" of water is left in pan bottom.
2. Turn humidity thermostat to "High" until water is gone.
3. Wipe out pan.

CAUTION

Delime or descale water pan parts as required, to prevent damaging build-up. WARRANTY COVERAGE MAY BE AFFECTED WITHOUT PROPER CLEANING.

MAINTENANCE: CABINET

1. Wipe the inside of cabinet after daily use.
2. Leave doors slightly open to fully dry interior.

WARNING

BEFORE cleaning the cabinet:

1. **Unplug cord from wall. Allow cabinet to cool.**
2. **Do NOT hose cabinet with water.**
3. **Do NOT use abrasives or harsh chemicals.**

Cleaning Hints:

1. Use the mildest cleaning procedure that will do the job.
2. Always rub in the direction of the polish lines to avoid scratching the surface.
3. Use only a soft cloth, sponge, fibrous brushes, plastic or stainless steel pad for cleaning and scouring.
4. Rinse thoroughly with fresh water after every cleaning operation.
5. Always wipe dry to avoid water marks.

HOW TO CLEAN THE UNIT:

	SOIL	CLEANER	METHOD
CABINET Inside and Outside (Stainless Steel)	ROUTINE CLEANING	Soap, Ammonia, or mild *detergent and water.	1. Sponge on with cloth. 2. Rinse with water. 3. Wipe dry.
	STUBBORN SPOTS AND STAINS	Mild abrasive made for stainless steel.	1. Apply with damp sponge or cloth. 2. Rub lightly.
	BURNT-ON FOODS OR GREASE	Chemical oven cleaner for stainless steel.	Follow oven cleaner manufacturer's directions.
	HARD WATER SPOTS and SCALE	Vinegar	1. Swab or wipe with cloth. 2. Rinse and dry.
<i>* Mild detergents include soaps and non-abrasive cleaners</i>			

MAINTENANCE INSTRUCTIONS: TROUBLE-SHOOTING GUIDE

WARNING

IF UNIT GETS TOO HOT OR WON'T SHUT OFF, DISCONNECT POWER AT BRANCH PANEL. DO NOT UNPLUG CORD!

If hot unit is *NOT* working, first check the following causes:

- | | |
|--|---|
| 1. Cord is unplugged from wall outlet. | 3. Switch is turned off. |
| 2. Circuit breaker/fuse to wall outlet is blown. | 4. Thermostat is turned off, or is set too low. |

PROBLEM	POSSIBLE CAUSE	SOLUTION
Humidity is low	1. Water in pan may be low 2. Thermostat set too low	1. Add water 2. Turn up thermostat
Cabinet does not heat, or doesn't heat properly	1. Fuse 2. Control 3. Sensor 4. Heater contactor 5. Loose wiring at heater contactor 6. On/Off Switch	1. Replace 2. Replace 3. Replace 4. Replace 5. Replace 6. Replace
Blowers do not operate	1. On/Off Switch 2. Fuse 3. Blower 4. Control	1. Replace 2. Replace 3. Replace 4. Replace
Heaters will not shut off	1. Thermostat 2. Contactor	1. Replace 2. Replace
Vent fan does not shut off	1. Vent fan switch defective 2. Control compartment is still hot.	1. Replace 2. Wait until it cools. Check "Heaters will not shut off."
Vent fan does not operate (See Note)	1. Fuse 2. Vent fan switch defective 3. Vent fan defective	1. Replace 2. Replace 3. Replace

NOTE: Vent fans will not operate until the control compartment requires ventilation to limit temperatures. Replacement of electrical components must be done by a qualified electrician. Refer to our *Service Agency list, FL-1400* (found in the back of this manual), of authorized service centers. Instructions for replacing parts are included in replacement parts list.

MAINTENANCE INSTRUCTIONS TROUBLE-SHOOTING GUIDE, continued

HOW TO ADJUST THE DOOR LATCH:

1. For vertical (up and down movement) adjustment:
 - a. Loosen (2) screws located in magnetic strike.
 - b. Move strike up or down for alignment to magnet on latch.
 - c. Tighten screws to secure
2. For horizontal (greater or lesser magnetic draw) adjustment:
 - a. Loosen (4) screws in door latch.
 - b. Move latch forward or backward to adjust magnetism.
 - c. Tighten screws to secure.

HOT UNIT REMOVAL:

1. Disconnect power cord from wall outlet.
2. For half-size model: CO151HW Series, remove screws around top cover.
3. Disconnect the yellow cord between top and bottom, in the back of the cabinet (see Figure 2).
4. Lift off Hot Unit.

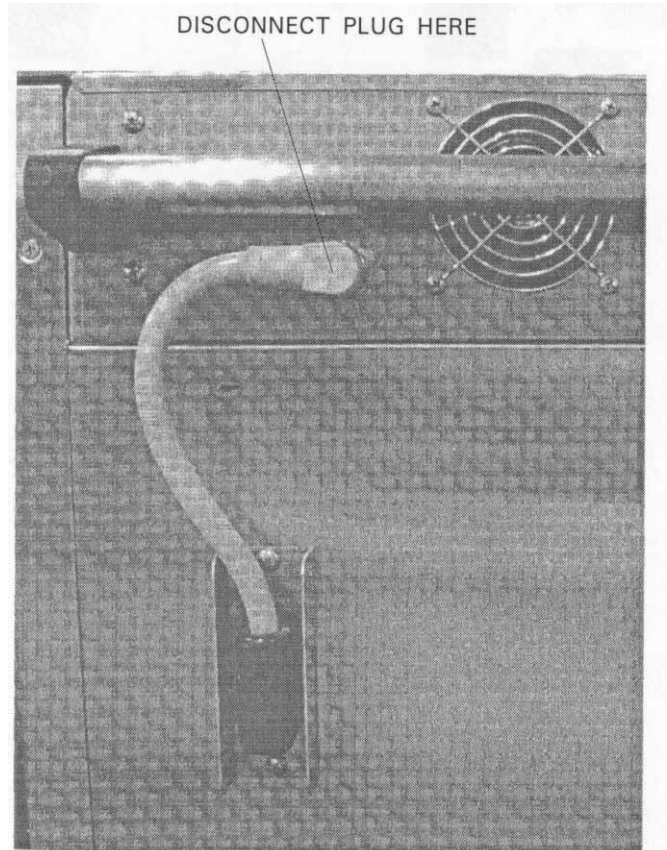

**FIGURE 2
HOT UNIT REMOVAL**

REPLACEMENT PARTS: *Include all information on nameplate when ordering parts.*

Cabinet Replacement Parts

MODEL PREFIX CO-151, RO-151					
DESCRIPTION	-FPWUA (12), (18)	-FWUA (12), (18)	-FW1332	-HWUA6	-XWUA5
Hot Unit, 208V, 1 Ph	HU675013	HU675025	HU675029	HU675037	HU675037
Hot Unit, 208V, 3 Ph	HU675015	HU675027	HU675031	HU675039	HU675039
Hot Unit, 240V, 1 Ph	HU675014	HU675026	HU675030	HU675038	HU675038
Hot Unit, 240V, 3 Ph	HU675016	HU675028	HU675032	HU675040	HU675040
Door Latch Kit	1006-120-01-K	1006-120-01-K	1006-120-01-K	1006-120-01-K	1006-120-01-K
Door Strike	1006-120-02-K	1006-120-02-K	1006-120-02-K	1006-120-02-K	1006-120-02-K
Door Hinge	0519-074-K	0519-074-K	0519-074-K	0519-074-K	0519-074-K
Door Assembly	1221-525-K	1221-525-K	1221-543-K	1221-525-K	1221-545-K
Door Gasket	0861-185-K	0861-185-K	0861-184	0861-185-K	0861-250-K
Angles or Racks	0621-281-SS-K	0621-281-SS-K	1104-108	0621-281-SS-K	0621-281-SS-K
Side Handles (2), Black Recessed	0911-102	0911-102	0911-102	0911-102	0911-102

REPLACEMENT PARTS

Include all information on nameplate when ordering parts

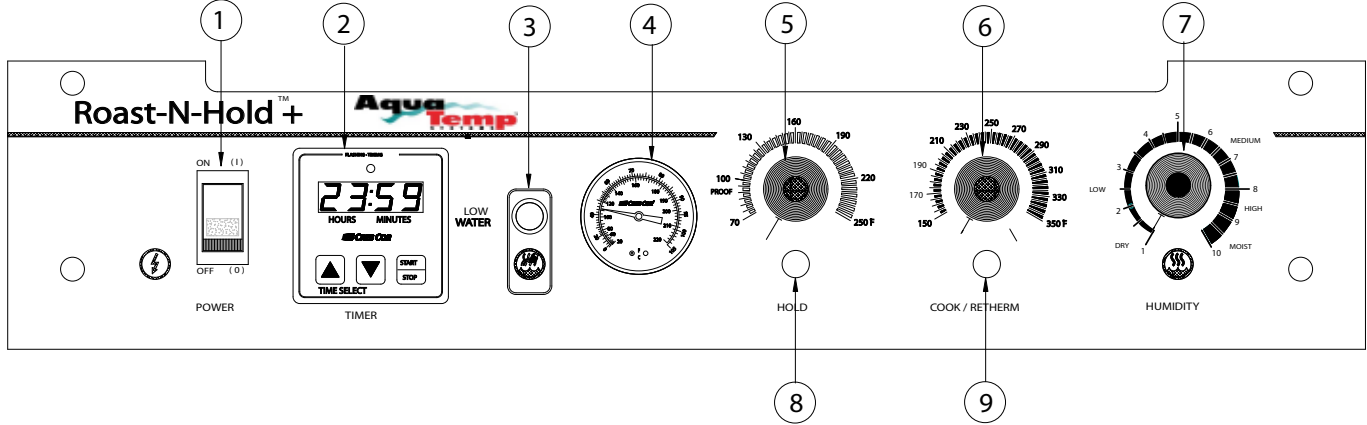

FIGURE 3: Control Panel

Hot Unit Replacement Parts

ITEM DESCRIPTION

ITEM DESCRIPTION	Part No.
1. Switch (On/Off)	0808-113-01-K
2. Timer, Digital	0849-088-K
Timer, Digital with Transformer	0849-088-K2
3. Light, Low Water	0766-095
4. Thermometer and Sensor	5238-031
5,6,7. Knob, Thermostat	0595-061
5,6. Control Board	0848-069
7. Thermostat	0848-008-ACK
8. Light, Yellow	0766-095
9. Light, Green	0766-097
12. Vent Fan	0769-174
13. Fan Guard	0769-167
14. Fuse (Before 7-08)	0807-058
Fuse (After 7-08)	0807-151
Fuse Holder (Before 7-08)	0807-048
Fuse Holder (After 7-08)	0807-150
15. Blower Kit	0769-182-01-SSK
16. Terminal Block	0852-096
17. Terminal Block	0852-093
18. Hi-Limit (Switch)	0848-079
19. Fan Switch	0848-034
20. Contactor	0857-026
21. Transformer	0769-159
22. Relay, Cook and Hold	0857-102
23. Resistor	0857-129
25. Relay (3PDT), Water	0857-125-K
26. Sensor – Thermostat	0848-058-K1
Sensor Bushing	0818-006
• Float Switch	0857-122
• Water Pan Kit, 208V	0756-030-K
• Heater, 208V	0811-278
• Water Pan Kit, 240V	0756-031-K
• Heater, 240V	0811-271

ITEM DESCRIPTION

ITEM DESCRIPTION	Part No.
PARTS for 8200W, 1-PH UNITS	
27. Power Cord	0810-124
28. Heater Kit, 208 V	0811-261
Heater Kit, 240 V	0811-262
29. Strain Relief	0818-061
PARTS for 8200W, 3-PH UNITS	
27. Power Cord	0810-132
28. Heater Kit, 208 V	0811-261
Heater Kit, 240 V	0811-262
29. Strain Relief	0818-050
PARTS for 4950W, 1-PH UNITS	
27. Power Cord	0810-163
28. Heater Kit, 208 V	0811-020-K
Heater Kit, 240 V	0811-020-01-K
29. Strain Relief	0818-050
PARTS for 4950W, 3-PH UNITS	
27. Power Cord	0810-164
28. Heater Kit, 208 V	0811-020-K
Heater Kit, 240 V	0811-020-01-K
29. Strain Relief	0818-050

Ovens	FL-2270
Rev. 12 (6/10)	Page 10 of 13

REPLACEMENT PARTS
for OVENS CO or RO 151FW SERIES:
Include all information on nameplate when ordering parts

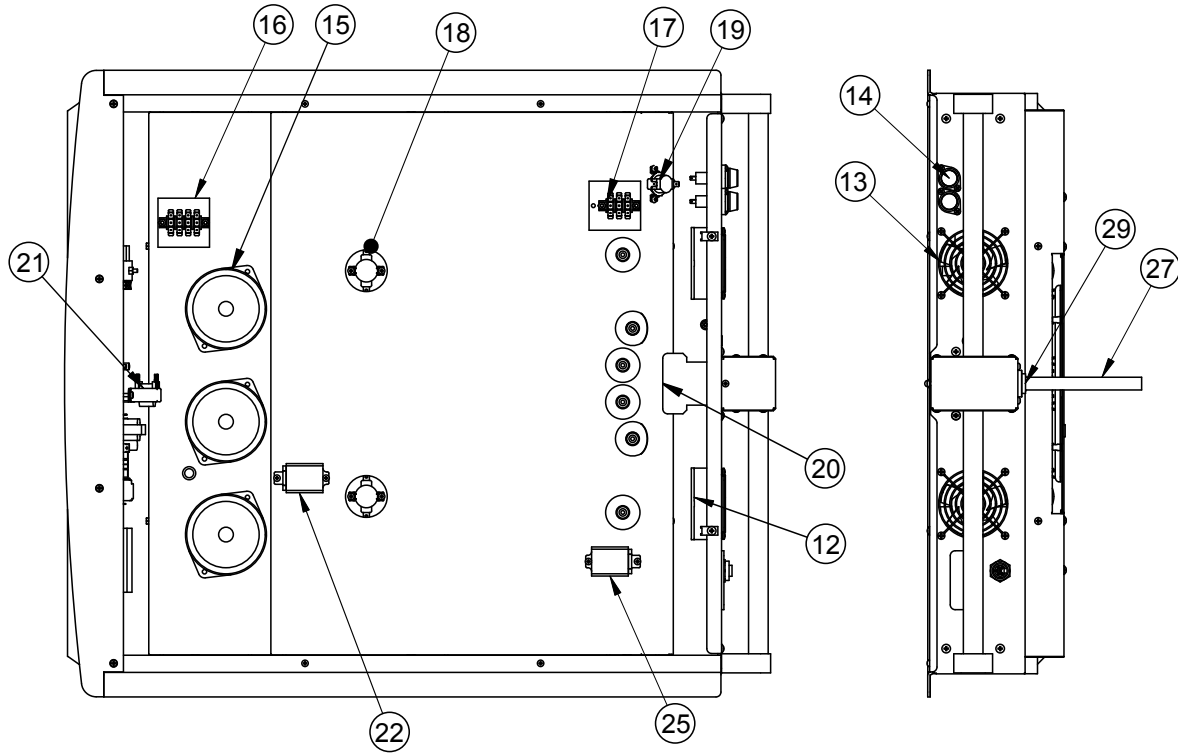

FIGURE 4; Hot Unit w/o Top cover
 (For parts description, refer to page 9.)

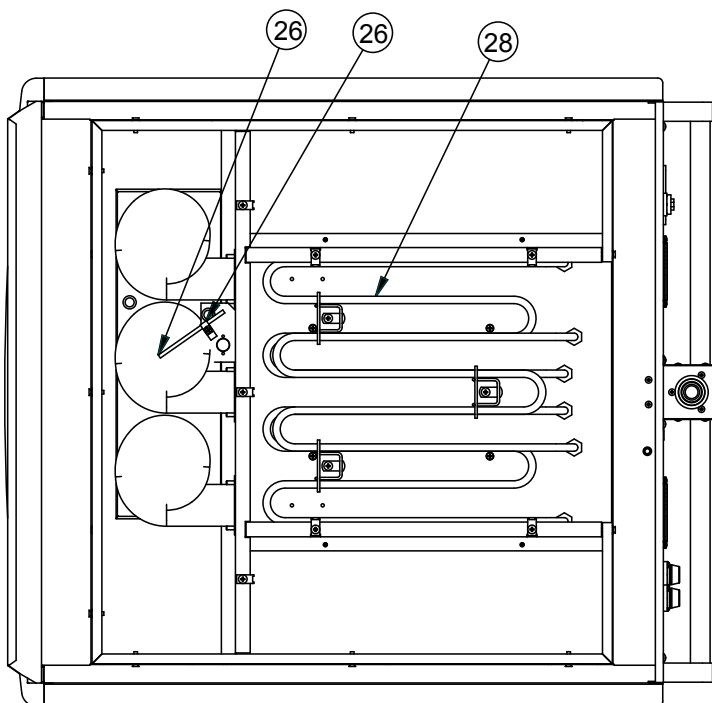

FIGURE 5;
Bottom of Hot Unit, Cover Removed
 (For parts description, refer to page 9.)

REPLACEMENT PARTS
for "PASS-THRU" OVENS CO or RO 151FW SERIES:
Include all information on nameplate when ordering parts

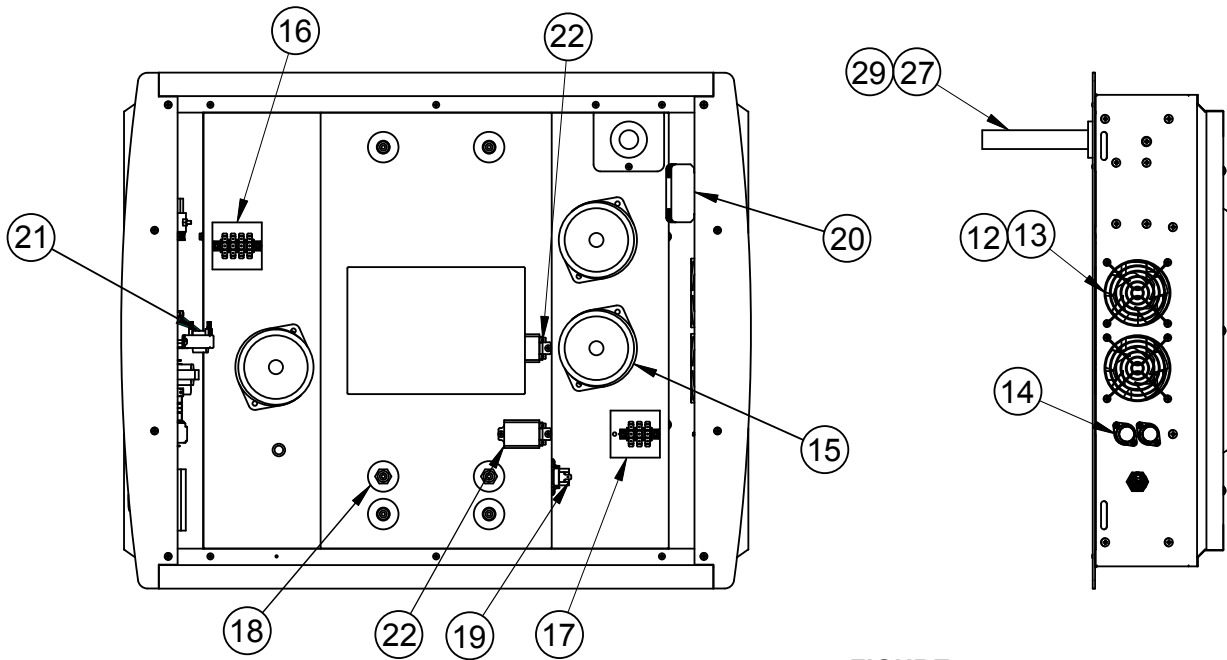

FIGURE 4;
Hot Unit w/o Top cover
(For parts description, refer to page 9.)

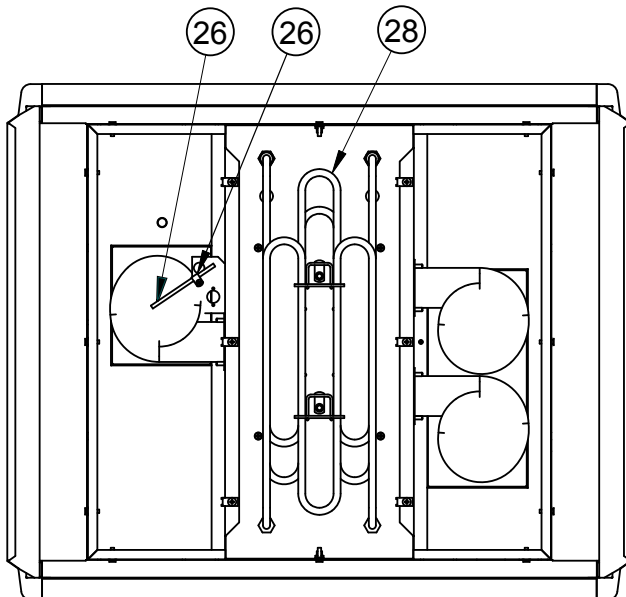
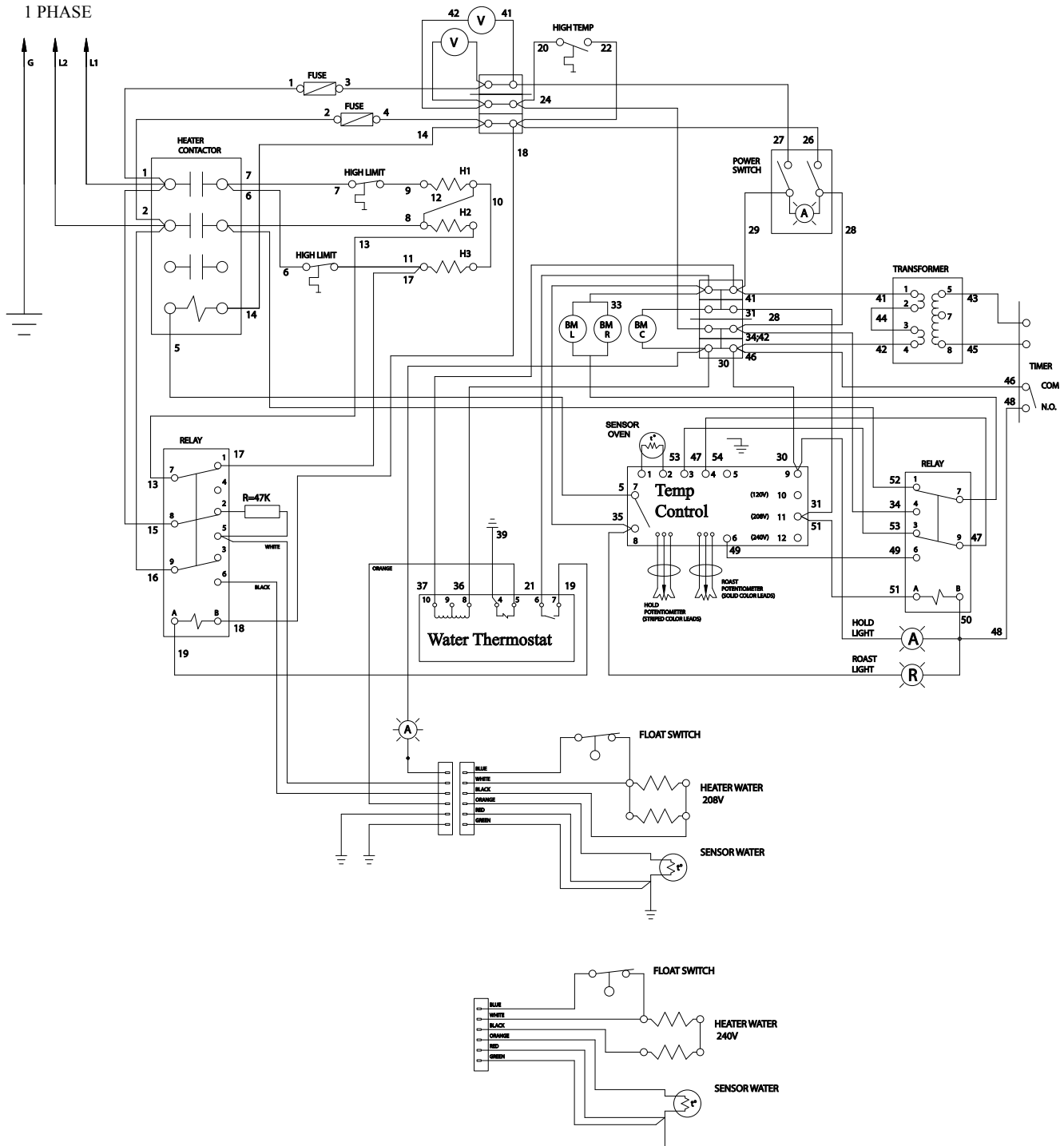

FIGURE 5;
Bottom of Hot Unit, Cover Removed
(For parts description, refer to page 9.)

WIRING DIAGRAM SINGLE PHASE



SINGLE PHASE

WIRING DIAGRAM THREE PHASE

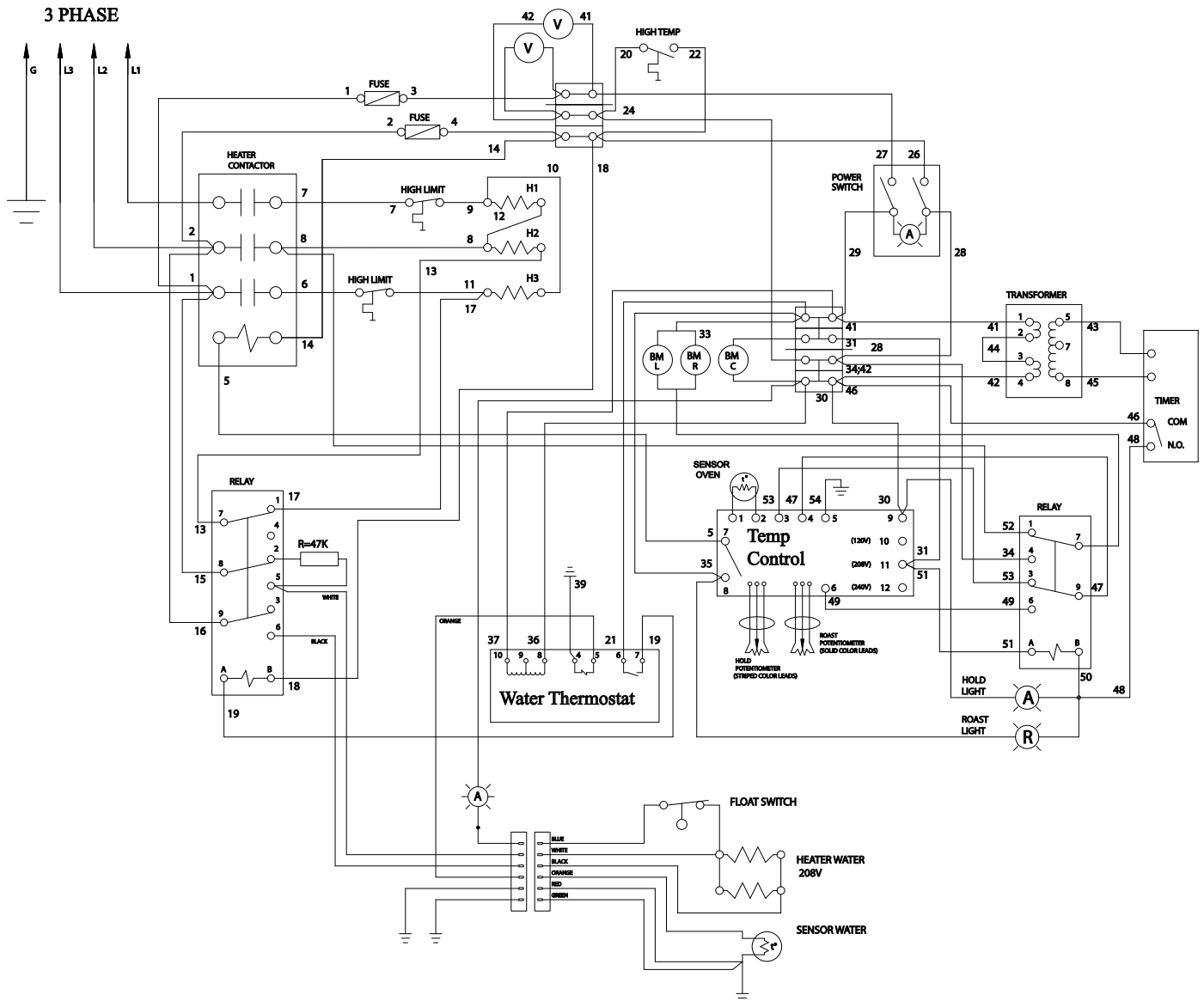

THREE PHASE