





# Installation Instructions

## SAFETY CONSIDERATIONS

Improper installation, adjustment, alteration, service, maintenance, or use can cause explosion, fire, electrical shock, or other conditions which may cause death, personal injury, or property damage. Consult a qualified installer, service agency, or your distributor or branch for information or assistance. The qualified installer or agency must use factory-authorized kits or accessories when modifying this product. Refer to the individual instructions packaged with the kits or accessories when installing.

Follow all safety codes. Wear safety glasses, protective clothing, and work gloves. Use quenching cloth for brazing operations. Have fire extinguisher available. Read these instructions thoroughly and follow all warnings or cautions included in literature and attached to the unit. Consult local building codes and current editions of the National Electrical Code ( NEC ) NFPA 70. In Canada, refer to current editions of the Canadian electrical code CSA 22.1.

Recognize safety information. This is the safety-alert symbol . When you see this symbol on the unit and in instructions or manuals, be alert to the potential for personal injury. Understand these signal words; DANGER, WARNING, and CAUTION. These words are used with the safety-alert symbol. DANGER identifies the most serious hazards which **will** result in severe personal injury or death. WARNING signifies hazards which **could** result in personal injury or death. CAUTION is used to identify unsafe practices which **would** result in minor personal injury or product and property damage. NOTE is used to highlight suggestions which **will** result in enhanced installation, reliability, or operation.

 **WARNING**

**ELECTRICAL SHOCK HAZARD**

Failure to follow this warning could result in personal injury or death.

Before installing, modifying, or servicing system, main electrical disconnect switch must be in the OFF position and install a lockout tag. There may be more than 1 disconnect switch. Lock out and tag switch with a suitable warning label.

 **WARNING**



**EXPLOSION HAZARD**

Failure to follow this warning could result in death, serious personal injury, and/or property damage.

Never use air or gases containing oxygen for leak testing or operating refrigerant compressors. Pressurized mixtures of air or gases containing oxygen can lead to an explosion.

## Indoor Thermostat Control Options

Model	Evolution Control	Standard 2-stage Thermostat
187B / 180B	Yes	Yes

## INSTALLATION RECOMMENDATIONS

**NOTE:** In some cases noise in the living area has been traced to gas pulsations from improper installation of equipment.

1. Locate unit away from windows, patios, decks, etc. where unit operation sound may disturb customer.
2. Ensure that vapor and liquid tube diameters are appropriate for unit capacity.
3. Run refrigerant tubes as directly as possible by avoiding unnecessary turns and bends.
4. Leave some slack between structure and unit to absorb vibration.
5. When passing refrigerant tubes through the wall, seal opening with RTV or other pliable silicon-based caulk. (See Fig. 1.)
6. Avoid direct tubing contact with water pipes, duct work, floor joists, wall studs, floors, and walls.
7. Do not suspend refrigerant tubing from joists and studs with a rigid wire or strap which comes in direct contact with tubing. (See Fig. 1.)
8. Ensure that tubing insulation is pliable and completely surrounds vapor tube.
9. When necessary, use hanger straps which are 1 in. (25.4 mm) wide and conform to shape of tubing insulation. (See Fig. 1.)
10. Isolate hanger straps from insulation by using metal sleeves bent to conform to shape of insulation.

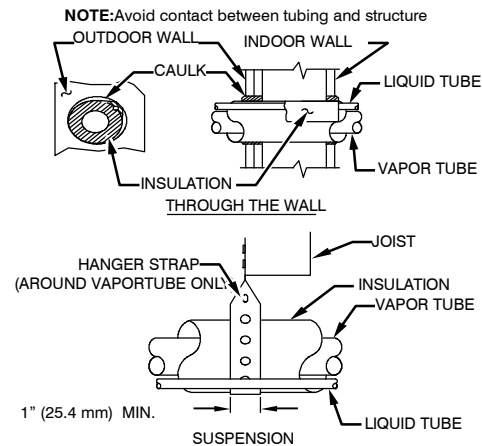

**Fig. 1 - Piping Installation**

The outdoor unit contains system refrigerant charge for operation with AHRI rated indoor unit when connected by 15 ft. (4.57 m) of field-supplied or factory accessory tubing. For proper unit operation, check refrigerant charge using charging information located on control box cover and/or in the Check Charge section of this instruction.

**IMPORTANT:** Maximum liquid-line size is 3/8-in. OD for all residential applications including long line.

**IMPORTANT:** Always install the factory-supplied liquid-line filter drier. If replacing the filter drier, refer to Product Data Digest for appropriate part number. Obtain replacement filter driers from your distributor or branch.

## INSTALLATION

### ⚠ CAUTION

#### CUT HAZARD

Failure to follow this caution may result in personal injury.

Sheet metal parts may have sharp edges or burrs. Use care and wear appropriate protective clothing and gloves when handling parts.

**IMPORTANT:** Effective January 1, 2015, all split system and packaged air conditioners must be installed pursuant to applicable regional efficiency standards issued by the Department of Energy.

### Check Equipment and Job Site

#### UNPACK UNIT

Move to final location. Remove carton taking care not to damage unit.

#### Inspect Equipment

File claim with shipping company prior to installation if shipment is damaged or incomplete. Locate unit rating plate on unit corner panel. It contains information needed to properly install unit. Check rating plate to be sure unit matches job specifications.

### Install on a Solid, Level Mounting Pad

If conditions or local codes require the unit be attached to pad, tie down bolts should be used and fastened through knockouts provided in unit base pan. Refer to unit mounting pattern in Fig. 2 to determine base pan size and knockout hole location.

For hurricane tie downs, contact local distributor for details and PE (Professional Engineer) certification, if required by local authorities.

On rooftop applications, mount on level platform or frame. Place unit above a load-bearing wall and isolate unit and tubing set from structure. Arrange supporting members to adequately support unit and minimize transmission of vibration to building. Consult local codes governing rooftop applications.

Roof mounted units exposed to winds may require wind baffles. Consult the Application Guideline and Service Manual - Residential Split System Air Conditioners and Heat Pumps for wind baffle construction.

**NOTE:** Unit must be level to within  $\pm 2^\circ$  ( $\pm 3/8$  in./ft.,  $\pm 9.5$  mm/m.) per compressor manufacturer specifications.

### Clearance Requirements

When installing, allow sufficient space for airflow clearance, wiring, refrigerant piping, and service. Allow 24 in. (609.6 mm) clearance to service end of unit and 48 in. (1219.2 mm) (above unit. For proper airflow, a 6-in. (152.4 mm) clearance on 1 side of unit and 12-in. (304.8 mm) on all remaining sides must be maintained. Maintain a distance of 24 in. (609.6 mm) between units. Position so water, snow, or ice from roof or eaves cannot fall directly on unit.

On rooftop applications, locate unit at least 6 in. (152.4 mm) above roof surface.

## Operating Ambient

The minimum outdoor operating ambient in cooling mode is 55°F (12.78°C) without low ambient cooling enabled in the Evolution Control, and the maximum outdoor operating ambient in cooling mode is 125°F (51.67°C). At line voltage of 208v (or below, and outdoor ambient of 120°F (48.9°C) (and above), the compressor operates in low stage. Low ambient cooling operation is possible at ambient as low as 0°F (-17.78°C) using UI Evolution controlled low ambient on 187B and 180B models and low ambient accessory kits on 187B models..

## Make Piping Connections

### ⚠ WARNING

#### PERSONAL INJURY AND ENVIRONMENTAL HAZARD

Failure to follow this warning could result in personal injury or death.

Relieve pressure and recover all refrigerant before system repair or final unit disposal. Use all service ports and open all flow-control devices, including solenoid valves.

Federal regulations require that you do not vent refrigerant to the atmosphere. Recover during system repair or final unit disposal.

### ⚠ CAUTION

#### UNIT DAMAGE HAZARD

Failure to follow this caution may result in equipment damage or improper operation.

If ANY refrigerant tubing is buried, provide a 6-in. (152.4 mm) vertical rise at service valve. Refrigerant tubing lengths up to 36-in. (914.4 mm) may be buried without further special consideration. Do not bury lines more than 36-in. (914.4 mm).

3/8-in. (9.53 mm) Dia.  
Tiedown Knockouts in  
Basepan(2) Places

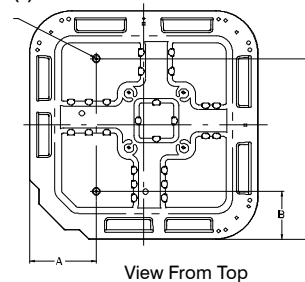

UNIT BASE PAN Dimension in. (mm)	TIEDOWN KNOCKOUT LOCATIONS in. (mm)		
	A	B	C
31-1/2 X 31-1/2 (800 X 800)	9-1/8 (231.8)	6-9/16 (166.7)	24-11/16 (627.1)
35 X 35 (889 X 889)	9-1/8 (231.8)	6-9/16 (166.7)	28-7/16 (722.3)

Fig. 2 - Tiedown Knockout Locations

A05177

**Table 1 – Accessory Usage**

Accessory	Required for Low Ambient Cooling Applications Utilizing 2–Stage Thermostat on 17 SEER Models Only (Below 55° F / 12.8° C)	Required for Low Ambient Cooling Applications Utilizing UI (Below 55° F / 12.8° C)	Required for Long Line Applications*	Required for Sea Coast Applications (within 2 miles/3.2 km)
Compressor Start Assist Capacitor and Relay	No	No	No	No
Crankcase Heater	Yes (standard on some units)	Yes (standard on some units)	Yes (standard on some units)	No
Evaporator Freeze Thermostat	Yes (kit required)	Standard with Evolution Control (no kit required)	No	No
Liquid Line Solenoid Valve	No	No	No	No
Low–Ambient Pressure Switch	Yes (kit required)	Standard with Evolution Control (no kit required)	No	No
Puron Refrigerant Balance Port Hard Shutoff TXV	Yes (standard w/factory approved indoor unit)	Yes (standard w/factory approved indoor unit)	Yes (standard w/factory approved indoor unit)	Yes (standard w/factory approved indoor unit)
Support Feet	Recommended	Recommended	No	Recommended
Winter Start Control	Yes (kit required)	Standard with Evolution Control (no kit required)	No	No

\* For tubing set lengths between 80 and 200 ft. (24.38 and 60.96 m) horizontal or 35 ft. (10.7 m) vertical differential (total equivalent length), refer to the Residential Piping and Long Line Guideline.

Outdoor units may be connected to indoor section using accessory tubing package or field-supplied refrigerant grade tubing of correct size and condition. Rated tubing diameters shown in Table 2 are recommended up to 80 ft. (24.38 m). See Product Data for acceptable alternate vapor diameters and associated capacity losses. For tubing requirements beyond 80 ft. (24.38 m), substantial capacity and performance losses can occur. Following the recommendations in the Residential Piping and Longline Guideline will reduce these losses. Refer to Table 2 for field tubing diameters. Refer to Table 1 for accessory requirements.

There are no buried-line applications greater than 36-in. (914.4 mm) allowed.

If refrigerant tubes or indoor coil are exposed to atmosphere, they must be evacuated to 500 microns to eliminate contamination and moisture in the system.

**Outdoor Unit Connected to Factory Approved Indoor Unit**

Outdoor unit contains correct system refrigerant charge for operation with factory approved AHRI rated indoor unit when connected by 15 ft. (4.57 m) of field-supplied or factory-accessory tubing, and factory supplied filter drier. Check refrigerant charge for maximum efficiency.

**NOTE:** If the indoor furnace coil width is more than the furnace casing width, refer to the indoor coil Installation Instructions for transition requirements.

**⚠ WARNING**

**UNIT OPERATION AND SAFETY HAZARD**

Failure to follow this warning could result in personal injury or equipment damage.

Puron® refrigerant systems operate at higher pressures than standard R-22 systems. Do not use R-22 service equipment or components on Puron® refrigerant equipment.

**Refrigerant Tubing Connection Outdoor**

Connect vapor and liquid tubes to fittings on vapor and liquid service valves (see Table 2.) Use refrigerant grade tubing.

**Sweat Connection**

**⚠ CAUTION**

**UNIT DAMAGE HAZARD**

Failure to follow this caution may result in equipment damage or improper operation.

Service valves must be wrapped in a heat-sinking material such as a wet cloth while brazing.

Use refrigeration grade tubing. Service valves are closed from factory and ready for brazing. After wrapping service valve with a wet cloth, braze sweat connections using industry accepted methods and materials. Consult local code requirements. Refrigerant tubing and indoor coil are now ready for leak testing. This check should include all field and factory joints.

**Table 2 – Refrigerant Connections and Recommended Liquid and Vapor Tube Diameters (In.)**

UNIT SIZE	LIQUID	RATED VAPOR*	
	Connection & Max. Tube Diameter	Connection Diameter	Tube Diameter
187BNA024	3/8	3/4	3/4
180BNA024	3/8	7/8	7/8
187/180BNA036	3/8	7/8	7/8
187/180BNA048	3/8	7/8	1-1/8
187/180BNA060	3/8	7/8	1-1/8

\* Units are rated with 25 ft. (7.6 m) of lineset. See Product Data sheet for performance data when using different size and length linesets.

**Notes:**

- Do not apply capillary tube or fixed orifice indoor coils to these units.
- For Tubing Set lengths between 80 and 200 ft. (24.38 and 60.96 m) horizontal or 35 ft. (10.7 m) vertical differential 250 ft. (76.2 m) Total Equivalent Length), refer to the Residential Piping and Longline Guide line– Air Conditioners and Heat Pumps using Puron refrigerant.
- For alternate liquid line options on 18–42 size units, see Product Data or Residential Piping and Application Guideline

## Install Liquid-Line Filter Drier Indoor



# CAUTION

### UNIT DAMAGE HAZARD

Failure to follow this caution may result in equipment damage or improper operation.

1. Installation of filter drier in liquid line is required.
2. Filter drier must be wrapped in a heat-sinking material such as a wet cloth while brazing.

Refer to Fig. 3 and install filter drier as follows:

1. Braze 5-in. liquid tube to the indoor coil.
2. Wrap filter drier with damp cloth.
3. Braze filter drier to above 5-in. (127 mm) liquid tube. Flow arrow must point towards indoor coil.
4. Connect and braze liquid refrigerant tube to the filter drier.

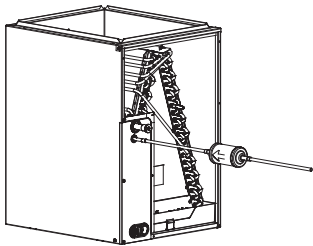

A05178

Fig. 3 - Liquid Line Filter Drier

## Evacuate Refrigerant Tubing and Indoor Coil



# CAUTION

### UNIT DAMAGE HAZARD

Failure to follow this caution may result in equipment damage or improper operation.

Never use the system compressor as a vacuum pump.

Refrigerant tubes and indoor coil should be evacuated using the recommended deep vacuum method of 500 microns. The alternate triple evacuation method may be used (see triple evacuation procedure in service manual). Always break a vacuum with dry nitrogen.

### Deep Vacuum Method

The deep vacuum method requires a vacuum pump capable of pulling a vacuum of 500 microns and a vacuum gage capable of accurately measuring this vacuum depth. The deep vacuum method is the most positive way of assuring a system is free of air and liquid water. A tight dry system will hold a vacuum of 1000 microns after approximately 7 minutes. See Fig. 4.

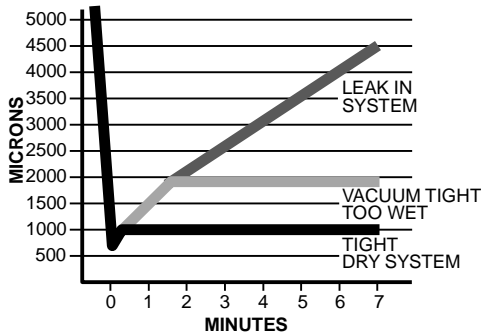

Fig. 4 - Deep Vacuum Graph

A95424

## Final Tubing Check

**IMPORTANT:** Check to be certain factory tubing on both indoor and outdoor unit has not shifted during shipment. Ensure tubes are not rubbing against each other or any sheet metal or wires. Pay close attention to feeder tubes, making sure wire ties on feeder tubes are secure and tight.

### Make Electrical Connections

Be sure field wiring complies with local and national fire, safety, and electrical codes, and voltage to system is within limits shown on unit rating plate. Contact local power company for correction of improper voltage. See unit rating plate for recommended circuit protection device.

**NOTE:** Operation of unit on improper line voltage constitutes abuse and could affect unit reliability. See unit rating plate. Do not install unit in system where voltage may fluctuate above or below permissible limits.

**NOTE:** Use copper wire only between disconnect switch and unit.

**NOTE:** Install branch circuit disconnect of adequate size per NEC to handle unit starting current. Locate disconnect within sight from and readily accessible from unit, per Section 440-14 of NEC.

### Route Ground and Power Wires

Remove access panel to gain access to unit wiring. Extend wires from disconnect through power wiring hole provided and into unit control box.



# WARNING

### ELECTRICAL SHOCK HAZARD

Failure to follow this warning could result in personal injury or death.

The unit cabinet must have an uninterrupted or unbroken ground to minimize personal injury if an electrical fault should occur. The ground may consist of electrical wire or metal conduit when installed in accordance with existing electrical codes.

### Connect Ground and Power Wires

Connect ground wire to ground connection in control box for safety. Connect power wiring to contactor as shown in Fig. 5.

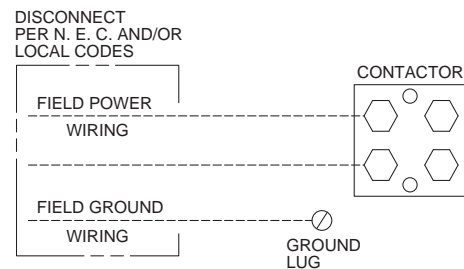

A91056

Fig. 5 - Line Connections

### Connect Control Wiring

This unit is capable of communication with an Evolution Control, or will operate using standard 24v 2-stage thermostat. Route 24-v control wires through control wiring grommet and connect leads to control board. When an Evolution User Interface is available, connect to A and B connections only. If additional grounding is needed, use C terminal. If a 2-stage thermostat is used, connect to the C, Y1, and Y2 connections. Refer to the wiring label to further clarification.

Use No. 18 AWG color-coded, insulated (35°C minimum) wire. If thermostat is located more than 100 ft. (30.48 m) from unit, as measured along the control voltage wires, use No. 16 AWG color-coded wire to avoid excessive voltage drop.

All wiring must be NEC Class 1 and must be separated from incoming power leads.

Use furnace transformer, fan coil transformer, or accessory transformer for control power, 24v/40va minimum.

**NOTE:** Use of available 24v accessories may exceed the minimum 40va power requirement. Determine total transformer loading and increase the transformer capacity or split the load with an accessory transformer as required.

### **Final Wiring Check**

**IMPORTANT:** Check factory wiring and field wire connections to ensure terminations are secured properly. Check wire routing to ensure wires are not in contact with tubing, sheet metal, etc.

### **Compressor Crankcase Heater**

When equipped with a crankcase heater, furnish power to heater a minimum of 24 hr before starting unit. To furnish power to heater only, set thermostat to OFF and close electrical disconnect to outdoor unit.

A crankcase heater is required if refrigerant tubing is longer than 80 ft. (24.38 m). Refer to the Application Guideline and Service Manual Longline Section-Residential Split-System Air Conditioners and Heat Pumps.

### **Airflow Setup for Evolution Control Furnace or FE Fan Coil (communicating)**

When using an Evolution User Interface, airflow is automatically selected based on equipment size. See User Interface Installation Instructions for available adjustments.

### **Airflow Selections (ECM Furnaces - non communicating)**

The ECM Furnaces provide blower operation to match the capacities of the compressor during high and low stage cooling operation. Tap selections on the furnace control board enable the installing technician to select the proper airflows for each stage of cooling. Below is a brief summary of the furnace airflow configurations

1. The Y2 call for high stage cooling energizes the “Cool” tap on the control board. The grey wire from cool tap is connected to tap 5 on the motor. Refer to the furnace Product Data to find the corresponding airflow. If the airflow setting for high cooling needs to be switched from tap 5 to a different tap, jumper a connection from the cool tap to the desired tap so that the Y2 signal is communicated via the cool tap to the desired speed tap.
2. The Y1 call for low stage cooling energizes the “Fan” tap on the control board. The red wire from the fan tap is connected to tap 1 on the motor. Refer to the furnace Product Data to find the corresponding airflow. If the airflow setting for low cooling needs to be switched from tap 1 to a different tap, jumper a connection from the Fan tap to the desired tap so that the Y1 signal is communicated via the Fan tap to the desired speed tap. The Y1 setting will also govern the continuous fan airflow for the furnace.

Refer to the literature for the furnace for further details.

### **Airflow Selection for Variable Speed Furnaces (non-communicating)**

The variable speed furnaces provide blower operation to match the capacities of the compressor during high and low stage cooling operation. The furnace control board allows the installing technician to select the proper airflows for each stage of cooling. Below is a summary of required adjustments. See furnace installation instructions for more details:

1. Turn SW1--5 ON for 400 CFM/ton airflow or OFF for 350 CFM/ton airflow. Factory default is OFF.
2. The A/C DIP switch setting determines airflow during high stage cooling operation. Select the A/C DIP switch setting corresponding to the available airflow shown in the furnace Installation Instructions that most closely matches the required airflow shown in the air conditioning Product Data for HIGH speed.
3. The CF DIP switch setting determines airflow during low stage cooling operation. Select the CF DIP switch setting corresponding to the available airflow shown in the furnace installation instructions that most closely matches the required airflow shown in the air conditioning Product Data for LOW speed. If a higher or lower continuous fan speed is desired, the continuous fan speed can be changed using the fan switch on the thermostat. Refer to the furnace Installation Instructions for details of how to use this feature.

### **Airflow Selection for FV4C Fan Coils (non-communicating)**

The FV4 provides high- and low-stage blower operation to match the capacities of the compressor at high- and low-stage.

To select recommended airflow, refer to the FV4C Installation Instructions. The FV4C utilizes an Easy Select control board that allows the installing technician to select proper airflows. This fan coil has an adjustable blower-off delay factory set at 90 sec. for high- and low-stage blower operation.

When using a communicating control with the fan coil or the furnace, dip-switch adjustments are not necessary. The outdoor unit configuration and the indoor airflows are determined by communicating control setup.

### **Start-Up**

 <b>CAUTION</b>
<b>UNIT OPERATION AND SAFETY HAZARD</b>
Failure to follow this caution may result in personal injury, equipment damage or improper operation.
<ul style="list-style-type: none"><li>• Do not overcharge system with refrigerant.</li><li>• Do not operate unit in a vacuum or at negative pressure.</li><li>• Compressor dome temperatures may be hot.</li></ul>

 <b>CAUTION</b>
<b>PERSONAL INJURY HAZARD</b>
Failure to follow this caution may result in personal injury.
Wear safety glasses, protective clothing, and gloves when handling refrigerant and observe the following:
<ul style="list-style-type: none"><li>• Front seating service valves are equipped with Schrader valves.</li></ul>

## SYSTEM FUNCTIONS AND SEQUENCE OF OPERATION

The 180B / 187B models utilize either an Evolution Communicating User Interface or a 2-stage cooling indoor thermostat. With a call for first stage cooling, the outdoor fan and low-stage compressor are energized. If low-stage cannot satisfy cooling demand, high-stage is energized by the second stage of indoor thermostat. After second stage is satisfied, the unit returns to low-stage operation until first stage is satisfied or until second stage is required again.

When both first stage and second stage cooling are satisfied, the compressor will shut off. When a 2-stage unit is operating at low-stage, system vapor (suction) pressure will be higher than a standard single-stage system or high-stage operation.

When the outdoor ambient is more than 100°F (37.8°C), the outdoor fan will continue to run for one minute after compressor shuts off. This reduces pressure differential for easier starting in the next cycle.

### Communication and Status Function Lights

#### For Evolution Control Only, Green communications (COMM)Light

##### Green LED (COMM Light)

A green LED (COMM light) on the outdoor board (see Fig. 6) indicates successful communication with the other system products. The green LED will remain OFF until communications is established. Once a valid command is received, the green LED will turn ON continuously. If no communication is received within 2 minutes, the LED will be turned OFF until the next valid communication.

##### Amber Status Light

An amber colored STATUS light is used to display the operation mode and fault codes as specified in the troubleshooting section. See Table 6 for codes and definitions.

**NOTE:** Only one code will be displayed on the outdoor unit control board (the most recent, with the highest priority).

##### Utility Interface with Evolution Control

The utility curtailment relay should be wired between R and Y2 connections on the control board for Evolution Communicating Systems only (see Fig. 12). This input allows a power utility device to interrupt compressor operation during peak load periods. When the utility sends a signal to shut the system down, the User Interface will display, “Curtailment Active”.

### Compressor Operation

The basic scroll design has been modified with the addition of an internal unloading mechanism that opens a by-pass port in the first compression pocket, effectively reducing the displacement of the scroll.

The opening and closing of the by-pass port is controlled by an internal electrically operated solenoid. The modulated scroll uses a single step of unloading to go from full capacity to approximately 67% capacity. A single speed, high efficiency motor continues to run while the scroll modulates between the two capacity steps.

Modulation is achieved by venting a portion of the gas in the first suction pocket back to the low side of the compressor, thereby reducing the effective displacement of the compressor. Full capacity is achieved by blocking these vents, thus increasing the displacement to 100%.

A DC solenoid in the compressor controlled by a rectified 24 volt AC signal in the external solenoid plug moves the slider ring that covers and uncovers these vents. The vent covers are arranged in such a manner that the compressor operates at approximately 67% capacity when the solenoid is not energized and 100% capacity

when the solenoid is energized. The loading and unloading of the two step scroll is done “on the fly” without shutting off the motor between steps.

**NOTE:** 67% compressor capacity translates to approximately 75% cooling capacity at the indoor coil. The compressor will always start unloaded and stay unloaded for five seconds even when the thermostat is calling for high-stage capacity.

### Crankcase Heater Operation

The crankcase heater is de-energized when the compressor is running. The crankcase heater is energized when the compressor is off and the ambient is less than 42°F (5.55°C). When the ambient temperature is between 65°F (18.33°C) and 42°F (5.55°C) the crankcase heater is energized 30 minutes after the compressor is turned off. When the ambient is above 65°F (18.33°C), the crankcase heater remains de-energized after the compressor is turned off.

### Outdoor Fan Motor Operation

The outdoor unit control energizes the outdoor fan any time the compressor is operating except for low-ambient cooling operation.

The outdoor fan remains energized if a pressure switch or compressor overload should open. Outdoor fan motor will continue to operate for one minute after the compressor shuts off when the outdoor ambient is greater than or equal to 100°F (37.78°C) to allow for easier starting during next cooling cycle.

On 187B models - The outdoor fan motor is a PSC type. A fan relay on the control board turns the fan off and on by opening and closing a high voltage circuit to the motor. It does not change speeds between low and high stage operation.

On 180B models - The outdoor fan is an ECM type. The motor control is continuously powered with high voltage. The motor speed is determined by electrical pulses provided by the PWM outputs on the control board. The ECM motor RPM adjusts to outdoor conditions as described in Table 3. The PWM output can be measured between the PWM1 and PWM2 terminals on the circuit board with a volt meter set to DC volts.

**Table 3 – Outdoor Fan Motor PWM**  
**Outdoor Temp (DC volts, Tolerance +/- 2%)**

Model	Low Stage (OAT≤104°F/40°C)	High Stage (OAT≤104°F/40°C)	Low & High Stage (OAT≤104°F/40°C)
180B024	9.57	10.88	11.90
180B036	9.06	10.23	11.90
180B048	9.91	11.04	11.90
180B060	10.83	11.70	11.90

**NOTE:** For 180A models in low-ambient cooling, the PWM output for both high- and low-stage equals the value for low-stage operation below 55°F (12.8°C).

In low ambient cooling (below 55°F/12.78°C) on 187B and 180B models, the control board cycles the fan off and on.

### Time Delays

The unit time delays include:

- Five minute time delay to start cooling or heating operation when there is a call from the thermostat or user interface. To bypass this feature, momentarily short and release Forced Defrost pins.
- Five minute compressor re-cycle delay on return from a brown-out condition.
- Two minute time delay to return to standby operation from last valid communication (with Evolution only).
- One minute time delay of outdoor fan at termination of cooling mode when outdoor ambient is greater than or equal to 100°F (37.78°C).
- There is no delay between staging from low to high and from high to low capacity. The compressor will change from low to high and from high to low capacity “on the fly” to meet the demand.

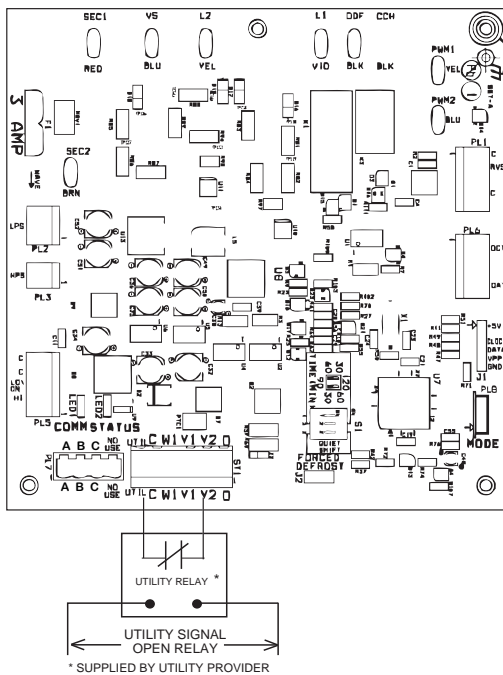

A12260

**Fig. 6 - 2-Stage Control Board**

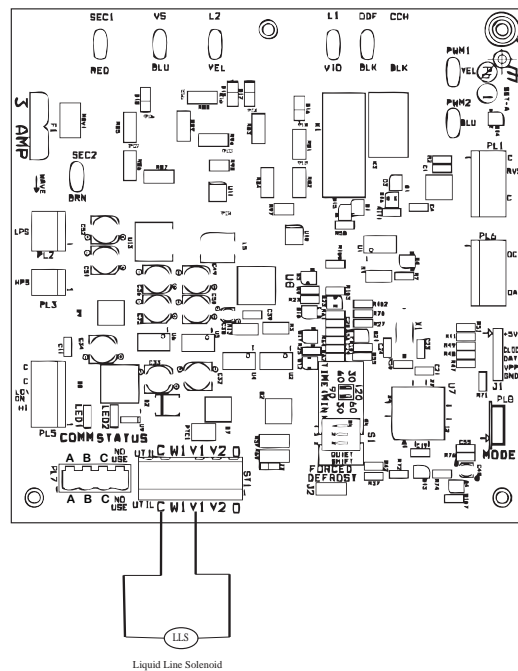

A12261

## Evolution Controlled Low Ambient Cooling

This unit is capable of low ambient cooling down to 0°F (-17.78°C) without a kit - ONLY when using Evolution control. A low ambient kit is not required, and the outdoor fan motor does not need to be replaced for Evolution controlled low ambient operation.

The Evolution Control provides an automatic evaporator coil freeze protection algorithm that eliminates the need for an evaporator freeze thermostat. Low ambient cooling must be enabled in the User Interface set up. Fan may not begin to cycle until about 40°F (4.4°C) OAT. Fan will cycle based on coil and outdoor air temperature.

Evolution controlled low ambient mode operates as follows:

- Fan is OFF when outdoor coil temp is less than outdoor air temperature (+3°F / 1.67°C) or outdoor fan has been ON for 30 minutes. (Fan is turned off to allow refrigerant system to stabilize.)
- Fan is ON when outdoor coil temp is more than outdoor air temperature (+ 25°F / 13.89°C) or outdoor coil temp is more than 80°F (26.67°C) or if outdoor fan has been OFF for 30 minutes. (Fan is turned on to allow refrigerant system to stabilize.)
- Low pressure switch is ignored for first 3 minutes during low ambient start up. After 3 minutes, if LPS trips, then outdoor fan motor is turned off for 10 minutes with the compressor running. If LPS closes within 10 minutes, then cooling continues with the outdoor fan cycling per the coil temperature routine listed above for the remainder of the cooling cycle. If the LPS does not close within 10 minutes, then the normal LPS trip response (shut down cooling operation and generate LPS trip error) will occur.
- The PWM output for both high and low-stage equals the value for low-stage operation, below 55°F (12.8°C).

## Check Charge

Models 180B / 187B should be charged in high stage compressor operation. Factory charge amount and desired subcooling are shown on unit rating plate. Charging method is shown on information plate inside unit. To properly check or adjust charge, conditions must be favorable for subcooling charging. Favorable conditions exist when the outdoor temperature is between 70°F and 100°F (21.11°C and 37.78°C), and the indoor temperature is between 70°F and 80°F (21.11°C and 26.67°C). Follow the procedure below:

Unit is factory charged for 15ft (4.57 m) of lineset. Adjust charge by adding or removing 0.6 oz/ft of 3/8 liquid line above or below 15ft (4.57 m) respectively.

For standard refrigerant line lengths (80 ft/24.38 m or less), allow system to operate in cooling mode at least 15 minutes. If conditions are favorable, check system charge by subcooling method. If any adjustment is necessary, adjust charge slowly and allow system to operate for 15 minutes to stabilize before declaring a properly charged system.

If the indoor temperature is above 80°F (26.67°C), and the outdoor temperature is in the favorable range, adjust system charge by weight based on line length and allow the indoor temperature to drop to 80°F (26.67°C) before attempting to check system charge by subcooling method as described above.

If the indoor temperature is below 70°F (21.11°C), or the outdoor temperature is not in the favorable range, adjust charge for line set length above or below 15ft (4.57 m) only. Charge level should then be appropriate for the system to achieve rated capacity. The charge level could then be checked at another time when the both indoor and outdoor temperatures are in a more favorable range.

**NOTE:** If line length is beyond 80 ft (24.38 m) or greater than 20 ft (6.10 m) vertical separation, See Long Line Guideline for special charging requirements.

## **Final Checks**

**IMPORTANT:** Before leaving job, be sure to do the following:

1. Ensure that all wiring is routed away from tubing and sheet metal edges to prevent rub-through or wire pinching.
2. Ensure that all wiring and tubing is secure in unit before adding panels and covers. Securely fasten all panels and covers.
3. Tighten service valve stem caps to 1/12-turn past finger tight.
4. Leave Owner's Manual with owner. Explain system operation and periodic maintenance requirements outlined in manual.
5. Fill out Dealer Installation Checklist and place in customer file.

## **CARE AND MAINTENANCE**

For continuing high performance and to minimize possible equipment failure, periodic maintenance must be performed on this equipment.

Frequency of maintenance may vary depending upon geographic areas, such as coastal applications. See Owner's Manual for information.

## TROUBLESHOOTING

If the compressor fails to operate with a cooling call, Table 4 can be used to verify if there is any damage to the compressor windings causing system malfunction.

**Table 4 – Winding Resistance**

Winding	Winding resistance at 70°F +/- 20°F (21.11°C +/- 11.11°C)			
	024	036	048	060
Start (S-C)	1.64	1.52	1.86	1.63
Run (R-C)	1.30	0.88	0.52	0.39

### Systems Communication Failure

If communication with the Evolution Control is lost with the user interface, the control will flash the appropriate fault code. (See Table 6) Check the wiring to the User Interface, indoor and outdoor units.

### Model Plug

Each control board contains a model plug. The correct model plug must be installed for or the system to operate properly (see Table 5).

**Table 5 – Model Plug**

Model Number	Model Plug Number	Pin Resistance (k - Ohms)	
		Pin 1 - 4	Pin 2 - 3
187B024	Hk70EZ040	18	75
187B036	Hk70EZ042	18	120
187B048	Hk70EZ044	18	180
187B060	Hk70EZ046	18	270
180B024	Hk70EZ009	5.1	91
180B036	Hk70EZ011	5.1	150
180B048	Hk70EZ013	5.1	220
180B060	Hk70EZ015	5.1	360

The model plug is used to identify the type and size of unit to the control.

On new units, the model and serial numbers are input into the board's memory at the factory. If a model plug is lost or missing at initial installation, the unit will operate according to the information input at the factory and the appropriate error code will flash temporarily.

An RCD replacement board contains no model and serial information. If the factory control board fails, the model plug must be transferred from the original board to the replacement board for the unit to operate.

**NOTE:** The model plug takes priority over factory model information input at the factory. If the model plug is removed after initial power up, the unit will operate according to the last valid model plug installed, and flash the appropriate fault code temporarily.

### Pressure Switch Protection

The outdoor unit is equipped with high and low pressure switches. If the control senses the opening of a high or low pressure switch, it will respond as follows:

1. De-energize the appropriate compressor contactor,
2. Keep the outdoor fan operating for 15 minutes,
3. Display the appropriate fault code (see Table 6).
4. After a 15 minute delay, if there is still a call for cooling and the LPS or HPS is reset, the appropriate compressor contactor is energized.
5. If LPS or HPS has not closed after a 15 minute delay, the outdoor fan is turned off. If the open switch closes anytime after the 15 minute delay, then resume operation with a call for cooling.
6. If LPS or HPS trips 3 consecutive cycles, the unit operation is locked out for 4 hours.
7. In the event of a high pressure switch trip or high pressure lockout, check the refrigerant charge outdoor fan operation and outdoor coil for airflow restrictions.
8. In the event of a low pressure switch trip or low pressure lockout, check the refrigerant charge and indoor airflow.

### Control Fault

If the outdoor unit control board has failed, the control will flash the appropriate fault code. (See Table 6) The control board should be replaced.

### Brown Out Protection

If the line voltage is less than 187v for at least 4 seconds, the appropriate compressor contactor and fan relay are de-energized. Compressor and fan operation are not allowed until voltage is a minimum of 190v. The control will flash the appropriate fault code (see Table 6)

#### **230 V Brown Out Protection Defeated:**

The brownout feature can be defeated if needed for severe noisy power conditions. This defeat should always be a last resort to solving the problem. Defeat is available on the User Interface setup screen (available with SYSTXBUID01-C UI) or can be initiated through the forced defrost pins for non-communicating systems as follows:

The brownout toggle is accomplished by shorting the defrost pins from power up with the OAT and OCT sensor connector removed. After 3 seconds, the status of the force defrost short and the OAT/OCT as open will be checked. If correct, then the brownout will be toggled.

- Status code 6 shows the brownout is disabled.
- Status code 5 shows the brownout is active.

After the brownout defeat is set, power down and reinstall the OAT/OCT sensor and remove the short from the forced defrost pins. As long as the short on the forced defrost remains, the OAT and OCT faults will not be cleared. The code will continue to be flashed.

The control is shipped with the brownout active. The change in status is remembered until toggled to a new status. A power down/power up sequence will not reset the status. It may be necessary to do the toggle twice to cycle to the desired state of the defeat.

#### **230V Line (Power Disconnect) Detection**

If there is no 230v at the compressor contactor(s) when the indoor unit is powered and cooling demand exists, the appropriate error code is displayed (see Table 6). Verify that the disconnect is closed and 230v wiring is connected to the unit.

## Compressor Voltage Sensing

The control board input terminals labeled VS and L2 (see Fig. 6) are used to detect compressor voltage status, and alert the user of potential problems. The control continuously monitors the high voltage on the run capacitor of the compressor motor. Voltage should be present any time the compressor contactor is energized, and voltage should not be present when the contactor is de-energized.

## Contactors Shorted Detection

If there is compressor voltage sensed when there is no demand for compressor operation, the contactor may be stuck closed or there is a wiring error. The control will flash the appropriate fault code.

## Compressor Thermal Cutout

If the control senses the compressor voltage after start-up, and is then absent for 10 consecutive seconds while cooling demand exists, the thermal protector is open. The control de-energizes the compressor contactor for 15 minutes, but continues to operate the outdoor fan.

The control Status LED will flash the appropriate code shown in Table 6. After 15 minutes, with a call for low or high stage cooling, the compressor contactor is energized. If the thermal protector has not reset, the outdoor fan is turned off. If the call for cooling continues, the control will energize the compressor contactor every 15 minutes. If the thermal protector closes, (at the next 15 minute interval check), the unit will resume operation. If the thermal cutout trips for three consecutive cycles, then unit operation is locked out for 4 hours and the appropriate fault code is displayed.

## No 230V at Compressor

If the compressor voltage is not sensed when the compressor should be starting, the appropriate contactor may be stuck open or there is a wiring error. The control will flash the appropriate fault code. Check the contactor and control box wiring.

## Troubleshooting units for proper switching between low & high stages

Check the suction pressures at the service valves. Suction pressure should be reduced by 3-10% when switching from low to high capacity.

**NOTE:** The liquid pressures are very similar between low and high stage operation so liquid pressure should not be used for troubleshooting.

Compressor current should increase 20 to 45% when switching from low to high stage. The compressor solenoid when energized in high stage, should measure 24vac across pin numbers PL5-2 HI and PL5-5 C. When the compressor is operating in low stage, the 24v DC compressor solenoid coil is de-energized. When the compressor is operating in high stage, the 24v DC solenoid coil is energized.

The solenoid plug harness that is connected to the compressor has an internal rectifier that converts the 24v AC signal to 24v DC.

**DO NOT INSTALL A PLUG WITHOUT AN INTERNAL RECTIFIER.**

## Unloader Test Procedure

The unloader is the compressor internal mechanism, controlled by the DC solenoid, that modulates between high and low stage. If it is suspected that the unloader is not working, the following methods may be used to verify operation.

1. Operate the system and measure compressor amperage. Cycle the unloader on and off at 30 second plus intervals at the UI (from low to high stage and back to low stage). Wait 5 seconds after staging to high before taking a reading. The compressor amperage should go up or down at least 20 percent.
2. If step one does not give the expected results, remove the solenoid plug from the compressor and, with the unit running and the UI (or Thermostat) calling for high stage, test the voltage output at the plug with a DC voltmeter. The reading should be 24 volts DC.
3. If the correct DC voltage is at the control circuit molded plug, measure the compressor unloader coil resistance. The resistance should be approximately 330 or 1640 ohms depending on unloader coil supplier. If the coil resistance is infinite or is grounded, the compressor must be replaced.

## MAJOR COMPONENTS

### 2-Stage Control

The 2-stage control board controls the following functions:

- Compressor high and low stage operation
- Outdoor fan motor operation
- Low ambient cooling
- Compressor external protection
- Pressure switch monitoring
- Time delays

### Field Connections

On models with non-communicating (non-Evolution) system, the 2-stage control receives 24vac low-voltage control system inputs through the C, Y1, and Y2 connections located at the bottom of the control board (see Fig. 10). The OD units can be controlled using a standard 2-stage thermostat or Evolution User Interface.

### 2-Stage Compressor

The 2-stage compressor contains motor windings that provide 2-pole (3500 RPM) operation. Refer to Table 4 for correct winding resistance.

### Compressor Internal Relief

The compressor is protected by an internal pressure relief (IPR) which relieves discharge gas into compressor shell when differential between suction and discharge pressures exceeds 550 - 625 psi. The compressor is also protected by an internal overload attached to motor windings.

### Compressor Control Contactor

The contactor has a 24 volt coil. The electronic control board controls the operation of the appropriate contactor.

## TEMPERATURE THERMISTORS

Thermistors are electronic devices which sense temperature. As the temperature increases, the resistance decreases. Thermistors are used to sense outdoor ambient (OAT) and coil temperature (OCT). Refer to Fig. 7 for resistance values versus temperature. If the outdoor ambient or coil thermistor should fail, the control will flash the appropriate fault code (see Table 6.)

**IMPORTANT:** Outdoor air thermistor and coil thermistor are factory mounted in the final locations. Check to insure thermistors are mounted properly per Fig. 8 and Fig. 9.

### Thermistor Sensor Comparison

The control continuously monitors and compares the outdoor air temperature sensor and outdoor coil temperature sensor to ensure proper operating conditions. The comparison is:

- If the outdoor air sensor indicates 10°F (5.56°C) warmer than the coil sensor (or) the outdoor air sensor indicates 20°F (11.11°C) cooler than the coil sensor, the sensors are out of range.
- If the sensors are out of range, the control will flash the appropriate fault code as shown in Table 6.
- The thermistor comparison is not performed during low ambient cooling or defrost operation.

### Failed Thermistor Default Operation

Factory defaults have been provided in the event of failure of outdoor air thermistor and/or coil thermistor.

If the OAT sensor should fail, low ambient cooling will not be allowed and the one minute outdoor fan-off delay will not occur.

If the OCT sensor should fail, low ambient cooling will not be allowed.

***OAT Thermistor must be locked in place with spherical nib end facing towards the front of the control box***

OAT Thermistor must be locked in place with spherical nib end facing towards the front of the control box

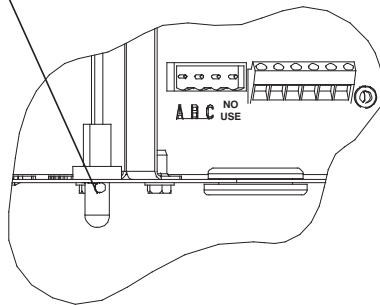

**Fig. 8 - Outdoor Air Thermistor (OAT) Attachment**

A12263

## Status Codes

Table 6 shows the status codes flashed by the amber status light. Most system problems can be diagnosed by reading the status code as flashed by the amber status light on the control board.

The codes are flashed by a series of short and long flashes of the status light. The short flashes indicate the first digit in the status code, followed by long flashes indicating the second digit of the error code.

The short flash is 0.25 seconds ON and the long flash is 1.0 second ON. Time between flashes is 0.25 seconds. Time between short flash and first long flash is 1.0 second. Time between code repeating is 2.5 seconds with LED OFF.

### EXAMPLE:

3 short flashes followed by 2 long flashes indicates a 32 code. Table 6 shows this to be low pressure switch open.

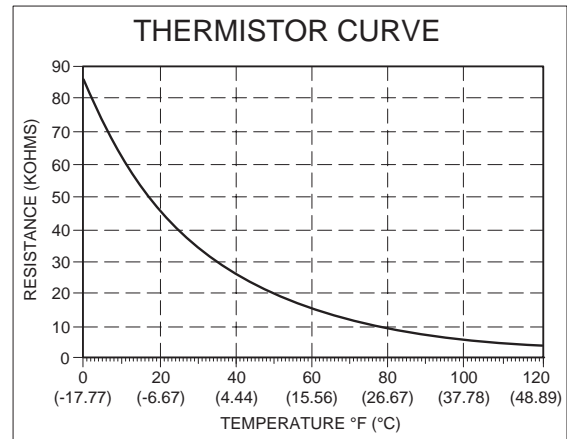

**Fig. 7 - Resistance Values Versus Temperature**

A08054

OCT Thermistor must be secured tight on the liquid tube.

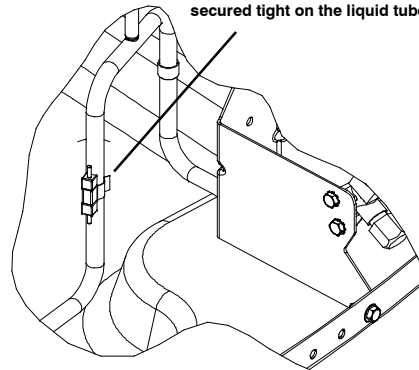

**Fig. 9 - Outdoor Coil Thermistor (OCT) Attachment**

A11143

**Table 6 – TROUBLESHOOTING**

OPERATION	FAULT	AMBER LED FLASH CODE	POSSIBLE CAUSE AND ACTION
Standby – no call for unit operation	None	On solid, no flash	Normal operation
Low Stage Cool/Heat Operation	None	1, pause	Normal operation
High Stage Cool/Heat Operation	None	2, pause	Normal operation
Brown out protection is Disabled	None	5, pause	User made selection, see instructions for more detail
Brown out protection is Active	None	6, Pause	User made selection, see instructions for more detail
	System Communications Failure	16	Communication with User Interface lost. Check wiring to User Interface, indoor and outdoor units
	Invalid Model Plug	25	Control does not detect a model plug or detects an invalid model plug. Unit will not operate without correct model plug.
	High Pressure Switch Open	31*	High –pressure switch trip. Check refrigerant charge, outdoor fan operation and coils for airflow restrictions.
	Low Pressure Switch or Discharge Temp Switch Open	32*	Low –pressure switch or discharge temperature switch trip. Check refrigerant charge and indoor air flow.
	Control Fault	45	Outdoor unit control board has failed. Control board needs to be replaced.
	Brown Out (230 v)	46	Line voltage < 187v for at least 4 seconds. Compressor and fan operation not allowed until voltage $\geq$ 190v. Verify line voltage.
	No 230v at Unit	47	There is no 230v at the contactor when indoor unit is powered and cooling/heating demand exists. Verify the disconnect is closed and 230v wiring is connected to the unit.
	Outdoor Air Temp Sensor Fault	53	Outdoor air sensor not reading or out of range. Ohm out sensor and check wiring.
	Outdoor Coil Sensor Fault	55	Coil sensor not reading or out of range. Ohm out sensor and check wiring.
	Thermistors out of range	56	Improper relationship between coil sensor and outdoor air sensor. Ohm out sensors and check wiring.
	Low Stage Thermal Cutout	71*	Compressor operation detected then disappears while low stage demand exists. Possible causes are internal compressor overload trip or start relay and capacitor held in circuit too long (if installed).
	High Stage Thermal Cutout	72*	Compressor operation detected then disappears while high stage demand exists. Possible causes are internal compressor overload trip or start relay and capacitor held in circuit too long (if installed).
	Contactor Shorted	73	Compressor voltage sensed when no demand for compressor operation exists. Contactor may be stuck closed or there is a wiring error.
	No 230V at Compressor	74	Compressor voltage not sensed when compressor should be starting. Contactor may be stuck open or there is a wiring error.
	Low Stage Thermal Lockout	81	Thermal cutout occurs in three consecutive low/high stage cycles. Low stage locked out for 4 hours or until 24v power recycled.
	High Stage Thermal Lockout	82	Thermal cutout occurs in three consecutive high/low stage cycles. High stage locked out for 4 hours or until 24v power recycled.
	Low –Pressure Lockout	83	Low pressure switch trip has occurred during 3 consecutive cycles. Unit operation locked out for 4 hours or until 24v power recycled.
	High –Pressure Lockout	84	High pressure switch trip has occurred during 3 consecutive cycles. Unit operation locked out for 4 hours or until 24v power recycled.

\* Sequence: Compressor contactor is de-energized and outdoor fan is energized for up to 15 minutes. If demand still exists, control will energize compressor contactor after 15 minute delay. If fault is cleared, unit will resume operation. If fault still exists, fan shuts off, and error code continues to flash. Control will attempt re –start every 15 minutes. Cycling low voltage defeats the 15 minute delay.

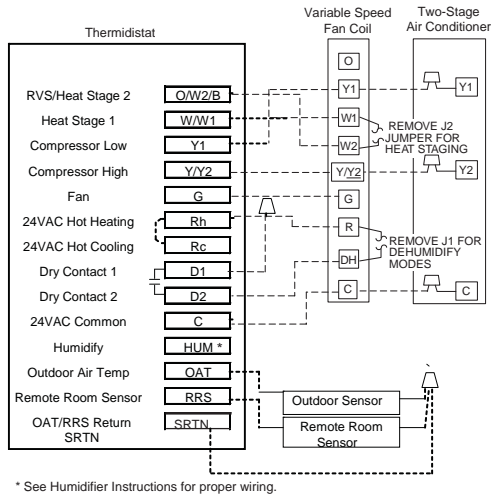

A12438

Thermostat Models T6-PRH01-A & T6-NRH01-A w/ VS Fan Coil & 2-Stage Air Conditioner

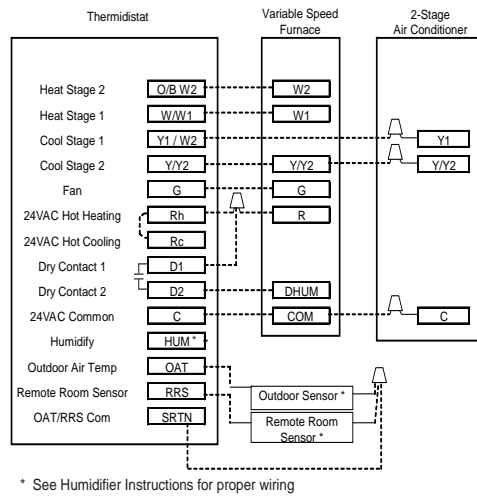

A12437

Thermostat Model T6-PRH01-A & T6-NRH01-A w/ VS Furnace & 2-Stage Air Conditioner

**Fig. 10 - Thermostat Wiring with 2-Stage Puron refrigerant Air Conditioner (set up as a non-communicating system)**

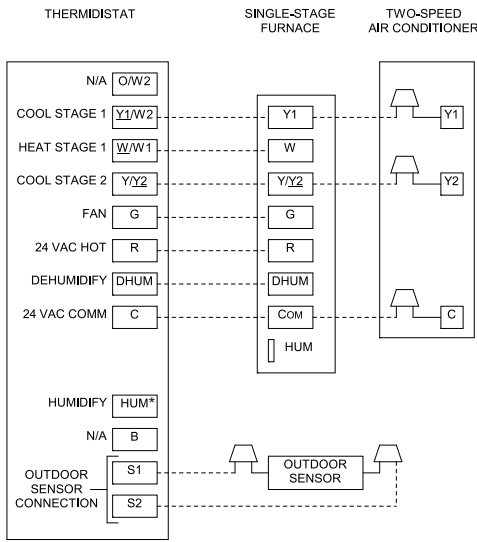

A12439

Single Stage Furnace with 2-Stage Air Conditioner

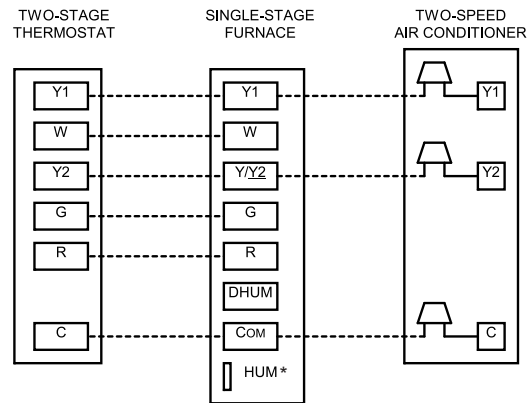

A12440

2-Stage Thermostat with Single-Stage Furnace and 2-Stage Air Conditioner

**Fig. 11 - VS Furnace or Fan Coil Wiring with 2-Stage AC (set up as a non-communicating system)**

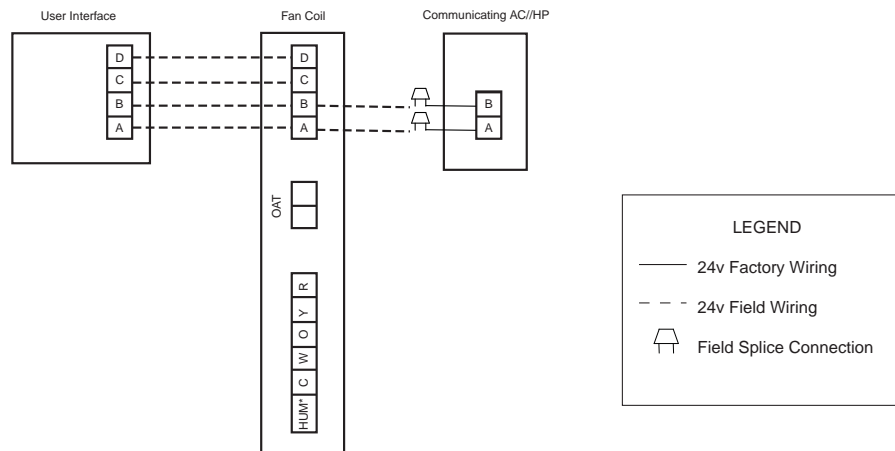

A12441

**Fig. 12 - Evolution Furnace or Fan Coil with 2-Stage AC (set up as a communicating system)**  
(See Thermostat Installation Instruction for specific unit combinations)

## PURON® (R-410A) REFRIGERANT QUICK REFERENCE GUIDE

- Puron refrigerant operates at 50–70 percent higher pressures than R-22. Be sure that servicing equipment and replacement components are designed to operate with Puron refrigerant
- Puron refrigerant cylinders are rose colored.
- Recovery cylinder service pressure rating must be 400 psig, DOT 4BA400 or DOT BW400.
- Puron refrigerant systems should be charged with liquid refrigerant. Use a commercial type metering device in the manifold hose when charging into suction line with compressor operating
- Manifold sets should be 700 psig high side and 180 psig low side with 550 psig low-side retard.
- Use hoses with 700 psig service pressure rating.
- Leak detectors should be designed to detect HFC refrigerant.
- Puron refrigerant, as with other HFCs, is only compatible with POE oils.
- Vacuum pumps will not remove moisture from oil.
- Do not use liquid-line filter driers with rated working pressures less than 600 psig.
- Do not leave Puron suction line filter driers in line longer than 72 hours.
- Do not install a suction-line filter drier in liquid line.
- POE oils absorb moisture rapidly. Do not expose oil to atmosphere.
- POE oils may cause damage to certain plastics and roofing materials.
- Wrap all filter driers and service valves with wet cloth when brazing.
- A factory approved liquid-line filter drier is required on every unit.
- Do NOT use an R-22 TXV.
- If indoor unit is equipped with an R-22 TXV or piston metering device, it must be changed to a hard shutoff Puron TXV.
- Never open system to atmosphere while it is under a vacuum.
- When system must be opened for service, recover refrigerant, evacuate then break vacuum with dry nitrogen and replace filter driers. Evacuate to 500 microns prior to recharging.
- Do not vent Puron refrigerant into the atmosphere.
- Do not use capillary tube coils.
- Observe all **warnings**, **cautions**, and **bold** text.
- All indoor coils must be installed with a hard shutoff Puron TXV metering device.

