

Wiring Diagrams

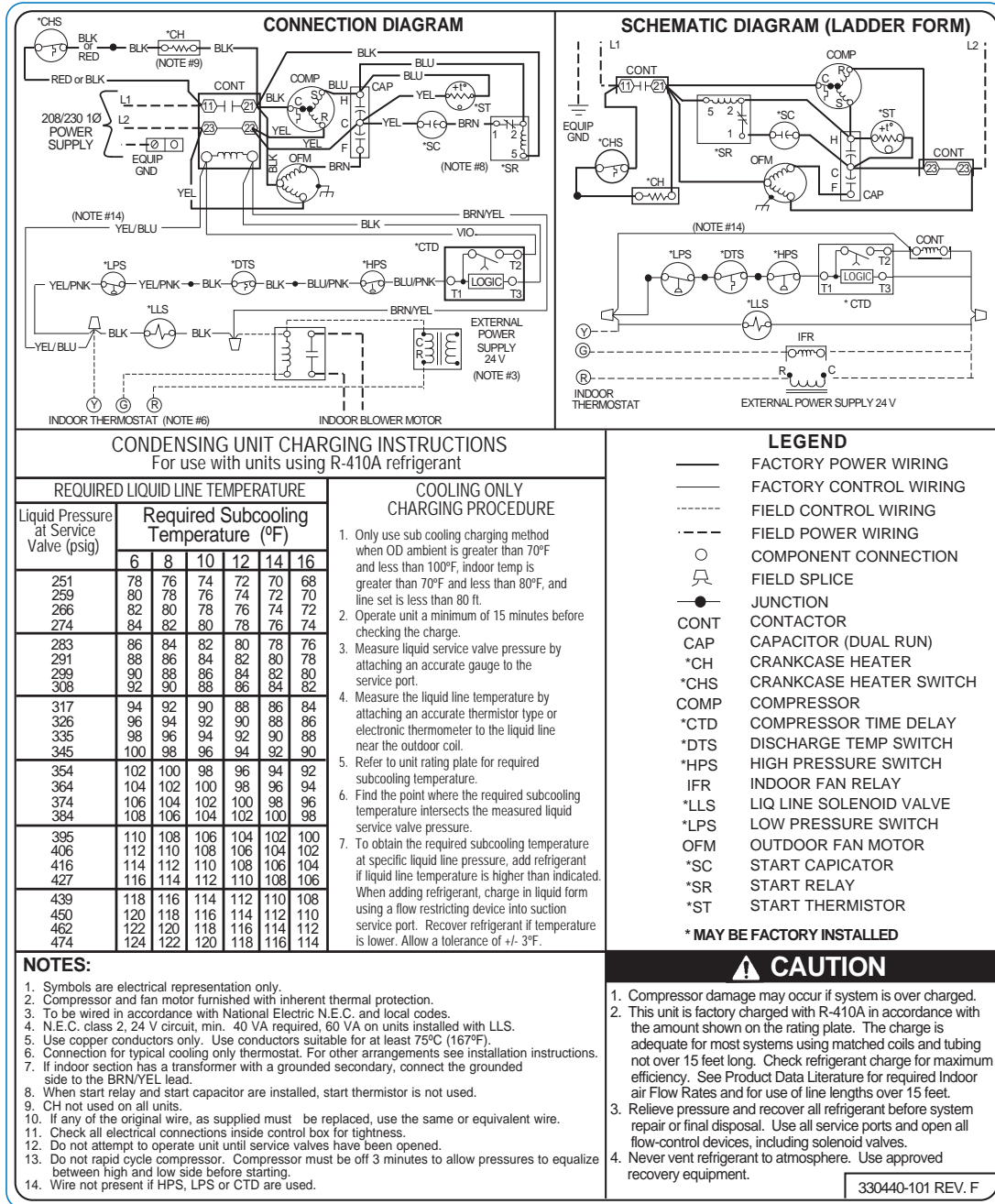

Fig. 1 – Wiring Diagram — Model sizes 1-1/2 - 5 tons, 208/230-1

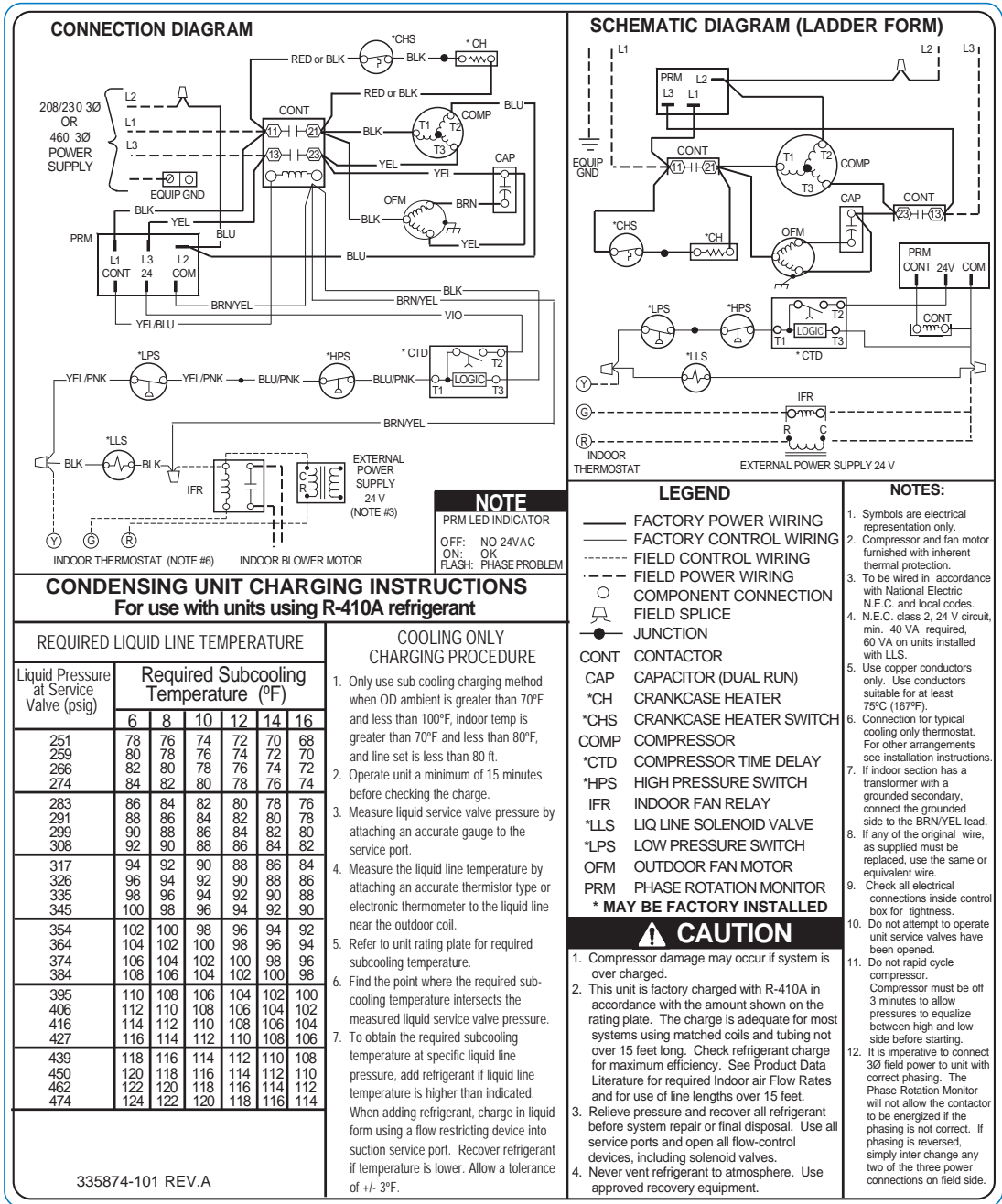

Fig. 2 – Wiring Diagram — Model size 2-1/2 - 5 tons, 208/230-3 and Model size 3 - 5 tons, 460/3

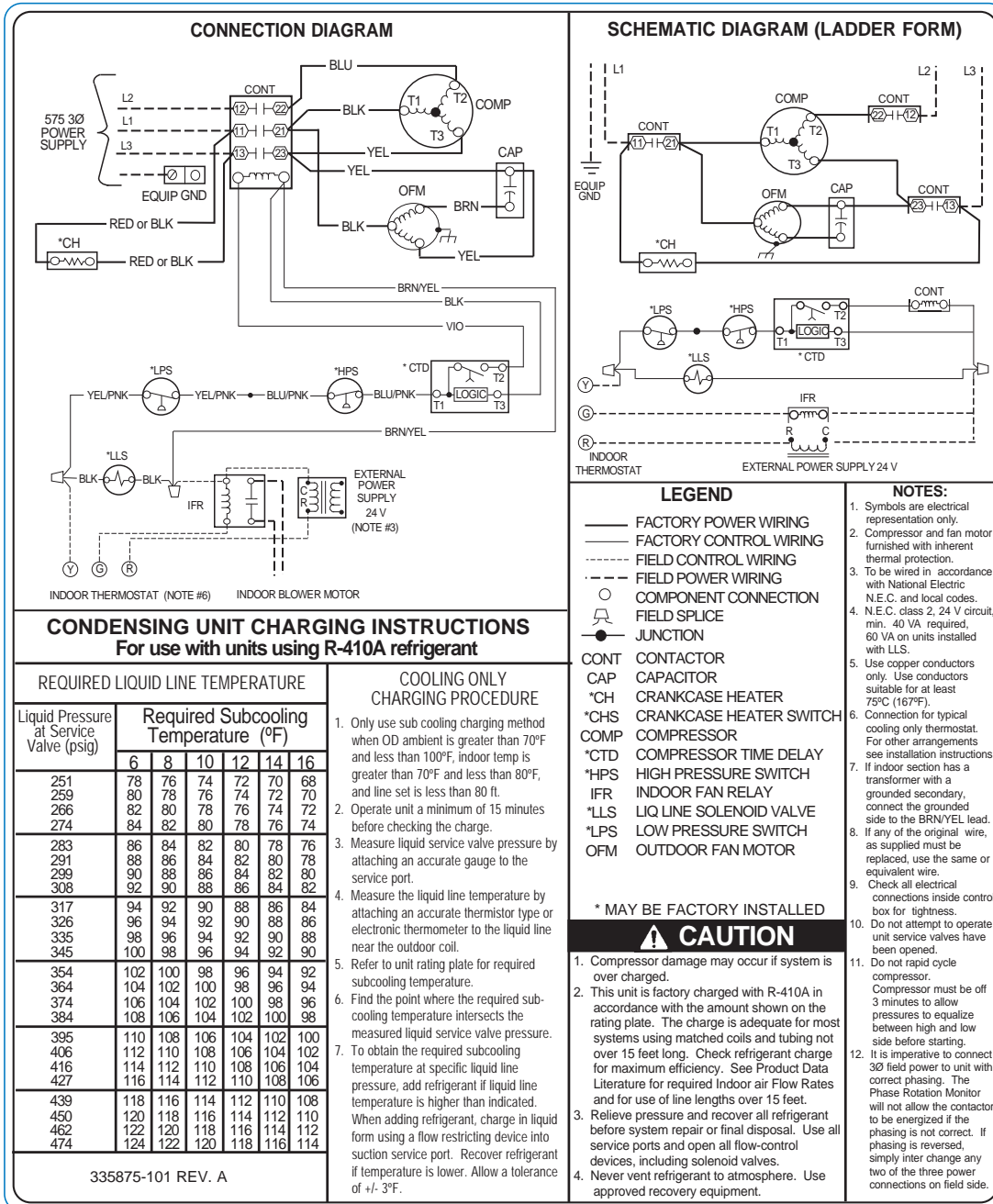

Fig. 3 – Wiring Diagram — Model size 3 - 5 tons, 575/3

